



**HAL**  
open science

## Ramiran 98

José Martinez, M.N. Maudet

► **To cite this version:**

José Martinez, M.N. Maudet. Ramiran 98. Cemagref Editions, pp.557, 1999, Coll. Actes de colloque, 2-85362-516-8. hal-02578508

**HAL Id: hal-02578508**

**<https://hal.inrae.fr/hal-02578508v1>**

Submitted on 13 Jun 2023

**HAL** is a multi-disciplinary open access archive for the deposit and dissemination of scientific research documents, whether they are published or not. The documents may come from teaching and research institutions in France or abroad, or from public or private research centers.

L'archive ouverte pluridisciplinaire **HAL**, est destinée au dépôt et à la diffusion de documents scientifiques de niveau recherche, publiés ou non, émanant des établissements d'enseignement et de recherche français ou étrangers, des laboratoires publics ou privés.

PUB00007176

ACTES DE  
COLLOQUE

Rennes  
26-29 mai 1998  
Cemagref France

# Ramiran 98

8th International Conference on Management  
Strategies for Organic Waste Use in Agriculture

8<sup>e</sup> conférence internationale sur les stratégies  
de gestion des déchets organiques en agriculture

*Edited by José Martinez and Marie-Noëlle Maudet*



CEN 39(4)

Cemagref  
EDITIONS



European System of Cooperative  
Research Networks in Agriculture  
(SCORENA)

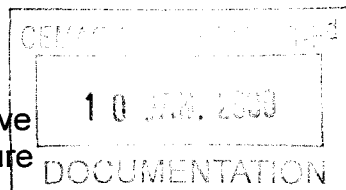

**Proceedings of the 8th International Conference  
on the FAO SCORENA Network  
on Recycling of Agricultural,  
Municipal and Industrial Residues in Agriculture  
(Formerly Animal Waste Management).  
Rennes, France, 26-29 May 1998**

## **RAMIRAN 98**

*Actes de la 8ème Conférence du Réseau FAO  
SCORENA sur le Recyclage des Déchets Agricoles,  
Municipaux et Industriels en Agriculture.  
Rennes, France, 26-29 mai 1998.*

*Edited by:  
José Martinez and Marie-Noëlle Maudet*

Proceedings of the Oral Presentations



The designations employed and the presentation of material in this publication do not imply the expression of any opinion whatsoever on the part of the Food and Agriculture Organization of the United Nations concerning the legal status of any country, territory, city or area or of its authorities, or concerning the delimitation of the frontiers or boundaries.

All rights reserved. No part of this publication may be reproduced, stored in a retrieval system, or transmitted in any form or by any means, electronic, mechanical, photocopying or otherwise, without the prior permission of the copyright owner. Applications for such permission, with a statement of the purpose and extent of the reproduction, should be addressed to :

- the Director, Information Division, Food and Agriculture Organization of the United Nations, Viale delle Terme di Caracalla, 00100 Rome, Italy.
- the Chef du service de l'IST, Cemagref, DSIC BP 44 92163 Antony Cedex, France

© FAO and Cemagref 1999

**RAMIRAN 98.** Actes de la 8<sup>e</sup> conférence internationale sur les Stratégies de gestion des déchets organiques en agriculture. Rennes 26 – 29 mai 1998. Coordination de l'édition : José Martinez et Marie-Noëlle Maudet. Impression et façonnage : imprimerie Cemagref, Antony, France. Vente par correspondance : Publi-Trans, BP 22, 91167 Longjumeau Cedex 9 - France, tél. 01 69 10 85 85. Diffusion aux libraires : Tec & Doc Lavoisier, 14, rue de Provigny, 94236 Cachan cedex – France  
© FAO et Cemagref 1999, ISBN 2-85362-516-8. Dépôt légal : 2<sup>e</sup> trimestre 1999. Prix : 380 F TTC (57,93 Euro TTC).

# Ramiran 98

8th International Conference on Management Strategies for Organic Waste Use in Agriculture.

*8ème Conférence Internationale sur les Stratégies de Gestion des Déchets Organiques en Agriculture.*

*Edited by José Martinez and Marie-Noëlle Maudet*

## **Advisory and Programme Committee :**

J. Martinez - Cemagref, France, Local Organizer.  
J.E. Hall - WRC, Network Co-ordinator, UK.  
J.C. Fardeau - INRA, France.  
B.F. Pain - IGER, North Wyke, UK.  
G. Guiraud - CEA, France.  
F. Béline - Cemagref, France.  
C.H. Burton - Silsoe Research Institute, UK.  
D. Chadwick - IGER North Wyke, UK.  
A. de Guardia - Cemagref, France.

## **Organizing Committee :**

J. Martinez, Conference Organizer.  
M.N. Maudet, Conference Secretary.  
F. Béline.  
P. Peu.  
F. Guiziou.  
D. Rogeau.  
A. de Guardia  
G. Le Bozec.

## **Avec la participation de :**

F. Roche - Cemagref Rennes, Directeur.  
R. Krell - FAO, Rome.  
I. Alvarez - FAO, Rome  
R. Pochat - Cemagref, Antony.  
J. Clément - Cemagref, DSIC Antony.  
C. Cédra - Cemagref, DSIC Antony.  
M. Boudot-Lamotte - Cemagref, Antony  
V. Lucas - Hôtel Mercure, Rennes.  
F. Egido - Cemagref, Rennes.

## Résumé

Ce volume rassemble les actes de la 8<sup>e</sup> Conférence Internationale d'un Réseau FAO sur le Recyclage des Déchets Agricoles, Municipaux et Industriels en Agriculture (réseau RAMIRAN, précédemment appelé Réseau sur la Gestion des Déjections Animales), qui s'est tenue à Rennes du 26 au 29 mai 1998. Le thème de la conférence était les stratégies de gestion des déchets organiques utilisés en agriculture, et celle-ci était organisée en 5 parties :

- Stratégies de gestion des déchets organiques utilisés en agriculture
- Valeur agronomique des déchets organiques
- Mesure, modélisation et maîtrise des émissions gazeuses
- Traitement et gestion des déchets
- Impacts environnementaux

Six articles sont présentés dans la première partie sur le thème des stratégies de gestion incluant les systèmes experts, la modélisation et les aspects réglementaires. La deuxième partie comprend 11 articles sur la valeur agronomique et débute par une synthèse qui rappelle les bases historiques de l'utilisation agricole des déchets organiques. Afin d'aboutir à un recyclage efficace, il est en effet nécessaire de bien connaître et prédire la disponibilité en éléments nutritifs. Les différentes étapes du recyclage de déchets organiques s'accompagnent également de diverses voies de fuites de composés gazeux indésirables pour l'environnement. On distingue notamment l'ammoniac ( $\text{NH}_3$ ), le protoxyde d'azote ( $\text{N}_2\text{O}$ ) et le méthane ( $\text{CH}_4$ ). Les inventaires et méthodes de réduction de ces gaz sont présentés à travers 9 articles dans la troisième partie de l'ouvrage. La quatrième partie décrit les techniques de traitement et de gestion des déchets, notamment des effluents d'élevage. Enfin la dernière partie présente les aspects environnementaux liés à l'utilisation de déchets organiques et notamment les métaux lourds apportés aux sols par les déjections animales et les aspects sanitaires.

Cet ouvrage rassemble les principaux auteurs impliqués sur ce domaine de recherche et présente, à la fois les derniers résultats de leurs travaux, mais également des considérations pratiques, nécessaires pour assurer une gestion optimisée des déchets organiques en agriculture.

## General Abstract

This volume contains the Proceedings of the 8th International Conference of the FAO ESCORENA Recycling of Agricultural, Municipal and Industrial Residues in Agriculture Network (RAMIRAN, formerly the Animal Waste Management Network), held in Rennes, France, from 26 to 29 May 1998. The theme of the Conference was Management Strategies for Organic Waste Use in Agriculture and the Conference was divided into five parts:

- Management strategies for organic waste use in agriculture
- Agronomic value of organic wastes
- Measurement, modelling and control of gaseous emissions
- Processing and handling of wastes
- Environmental impacts

Six papers were presented in Part 1 on the theme: Management Strategies Covering Expert Systems, Modelling and Legislation. The second part consisted of 11 papers on the agronomic value including a review describing the historical basis for the application of organic wastes to land. To achieve proper recycling, it is essential to understand the crop availability of nutrients. The various stages of organic waste recycling provide numerous opportunities for the escape of environmentally active gases. The gases of greater concern include ammonia ( $\text{NH}_3$ ), nitrous oxide ( $\text{N}_2\text{O}$ ) and methane ( $\text{CH}_4$ ). Inventories and methods for controlling these emissions were explored through 9 papers presented in Part 3. Part 4 covered the different aspects of handling and processing wastes in general. Special attention was given to animal manure, but also other wastes were considered. The final part on environmental aspects was mainly devoted to the metal content in animal wastes (4 papers) and hygienic problems.

The book brings together the leading workers in the area and provides an up-to-date account of the research together with implications for practical recommendations in this environmentally sensitive field.

These considerations led us to the conclusion that this book is timely and fills a void on a subject that lacks integrated scientific information.



## Table of Contents

Preface.....	11
<b>Part 1. Management Strategies for Organic Waste Use in Agriculture.</b> .....	<b>13</b>
Management strategies related to legislative, economic, agronomic and environmental impact of organic wastes .....	15
<i>J.M. Mérillot (France).</i>	
Developing a decision support system for manure management. ....	25
<i>M. J. Goss, J.R. Ogilvie, D.P. Stonehouse, (Canada).</i>	
SWAMP. Optimising the use of slurry.....	37
<i>J.J. Lenehan (Ireland), T. Cumby (U.K), J. Huijsmans (The Netherlands), F. Lorenz (Germany), G. Provolo (Italy), J. Perros (Greece), M. McGechan (U.K.).</i>	
Mineral bookkeeping, new manure legislation in the Netherlands. ....	49
<i>P.J.L. Derikx (The Netherlands).</i>	
The implications of Irish legislation and regulations for the land spreading of manures from intensive agricultural enterprises.....	59
<i>O.T. Carton, W.L. Magette (Ireland).</i>	
A management model for pathogen abatement in animal slurry in view of its agronomic use. ....	73
<i>G. Provolo, P. Morandi, F. Sangiorgi (Italy).</i>	
<b>Chairman's Summary of Part 1</b> .....	<b>81</b>
<b>Part 2. Agronomic Value of Organic Wastes</b> .....	<b>83</b>
Assessment of nutrient availability from organic wastes use in agriculture. A review.....	85
<i>J.C. Fardeau (France).</i>	
Field studies of farm manure organic nitrogen mineralisation.....	101
<i>J.R. Williams, B.J. Chambers, A. Bhogal, D. R. Chadwick, B.F. Pain (U.K.).</i>	
Short term carbon and nitrogen transformations following pig and cattle slurry incorporation in soils.....	113
<i>T. Morvan, P. Leterme (France).</i>	
Nitrogen efficiency of solid animal manures.....	129
<i>F. Lorenz, C. Kalzendorf, G. Steffens (Germany).</i>	

The effect of organic fertilization on the crop yields and soil properties.....	137
<i>J. Klir, P. Ruzek (Czech Republic), I.A. Arkhipchenko (Russia)</i>	
Composting of swine slurry : firsts results .....	147
<i>P. Balsari, G. Airoidi (Italy).</i>	
Emission of ammonia, nitrous oxide, methane and carbon dioxide during composting of deep litter. ....	157
<i>S.G. Sommer, P. Dahl, H.B. Rom, H.B. Moller (Denmark)</i>	
Composting of organic wastes as a strategy for producing high quality organic fertilizers .....	171
<i>M.P. Bernal, J. Cegarra, A. Roig, M.A. Sanchez-Monedero, C. Paredes (Spain).</i>	
Characterization of green wastes' transformations occuring while composting .....	185
<i>A. de Guardia, D. Rogeau, F. Begnaud, S. Quinio (France)</i>	
Development and solid manure technologies.....	203
<i>G. Meszaros (Hungary)</i>	
Landspreading of industrial wastes. ....	213
<i>R.D. Davis, (U.K.)</i>	
<b>Chairman's Summary of Part 2</b> .....	229
<b><u>Part 3. Measurement, Modelling and Control of Gaseous Emissions</u></b> ..	231
Gaseous pollutants from organic waste use in agriculture.....	233
<i>B. Pain (U.K.).</i>	
Influence of slurry pretreatments and application techniques on ammonia emissions after landspreading of slurry on grassland. ....	247
<i>P. Reitz, H.D. Kutzbach (Germany)</i>	
Gaseous emissions from dairy cattle collecting yards.....	257
<i>T. H. Misselbrook, B.F. Pain, D.R. Chadwick, D.H. Headon (U.K.).</i>	
Emissions of NH <sub>3</sub> , N <sub>2</sub> O and CH <sub>4</sub> from a tying stall for milking cows, during storage of farmyard manure and after spreading .....	269
<i>B. Amon, Th. Amon, J. Boxberger, A. Pöllinger (Austria)</i>	
Methane and nitrous oxide emissions from UK agricultural livestock. ....	279
<i>D.R. Chadwick, R.W. Sneath, V.R. Phillips, B.F. Pain (U.K.).</i>	



Simulation of the behaviour of sewage sludges in a soil : variations with sludge treatment.....	293
<i>S. Houot, G. Delaitre, S. Bourgeois (France)</i>	
Proposal of an integrated approach to characterize « the nitrogen value » of organic products spread in agriculture. ....	305
<i>B. Nicolardot, J.M. Machet, V. Parnaudeau, F. Marcovecchio (France).</i>	
A model approach for ammonia volatilisation after surface application and subsequent incorporation of manure on arable land. ....	317
<i>J.F.M. Huijsmans, R.M. de Mol (The Netherlands).</i>	
Using a mechanistic model for evaluating ammonia emissions abatement techniques after organic fertilization. ....	333
<i>S. Génarmont, P. Cellier (France).</i>	
<b>Chairman's Summary of Part 3</b> .....	345
<b><u>Part 4. Processing and Handling of Wastes</u></b> .....	347
Processing strategies for organic wastes.....	349
<i>C.H. Burton (U.K.).</i>	
The effect of continuous and intermittent aerobic treatment of pig slurry on nitrous oxide emissions. ....	365
<i>F. Béline, J. Martinez (France).</i>	
Anaerobic processing of slaughterhouse wastewater in a SBR.....	375
<i>D.I. Massé, L. Masse, N. Bourgeois (Canada).</i>	
Comprehensive pig manure treatment using the BIOSOR™ biofiltration process. ....	389
<i>G. Buelna, R. Dubé, M.C. Michel, N. Turgeon, Y. Bernad, P. Lessard (Canada).</i>	
Biogas production in agriculture : safety guidelines, cofermentation and emissions from combined heat and power couplings. ....	405
<i>T. Amon, J. Boxberger, J. Lindworsky, M. Scheibler (Austria).</i>	
Using the thermophilic aerobic process to decompose industrial food wastes. ....	417
<i>J. Matsuda, T. Maeda, Y. Abe, S. Nakamura, K. Ohmiya (Japan).</i>	
Ammonia removal from swine wastewater using immobilized nitrifiers.....	427
<i>M.B. Vanotti, P.G. Hunt (U.S.A.).</i>	

Microbial fertilizers from pig farm wastes. ....	439
<i>I. Arkhipchenko (Russia).</i>	
Application of zeolite (clinoptilolite) in the process of stabilization of the solid fraction of pig slurry. ....	449
<i>M. Vargová, O. Ondrasovicová, M. Ondrasovic, L' Para, J. Venglovsky, N. Sasáková (Slovak Republic).</i>	
Physical characterisation of animal manure. ....	457
<i>F. Thirion, F. Chabot, D. Andeler (France).</i>	
<b>Chairman's Summary of Part 4</b> .....	471
<b><u>Part 5. Environmental Impacts</u></b> .....	473
Heavy metal loadings from animal manures to agricultural land in england and wales. ....	475
<i>B.J. Chambers, F.A. Nicholson, D.R. Soloman, R.J. Unwin (U.K.).</i>	
Copper soil retention capacity after intensive and repeated pig slurry applications.....	485
<i>L. L'Herroux, S.M. Le Roux, J. Martinez (France).</i>	
Heavy metal content of manures in Switzerland. ....	495
<i>H. Menzi, J. Kessler (Switzerland).</i>	
Effects of solid phase from pig slurry on soil and wheat micronutrient's content.....	507
<i>F. Cabral, E. Vasconcelos, C. M d S Cordovil (Portugal).</i>	
Hygienic quality of source separated urine based on the analysis of faecal indicator bacteria .....	517
<i>C. Høglund, T.A. Stenström, A. Sundin, H. Jönsson, B. Vinneras (Sweden).</i>	
Inactivation of viral and bacterial pathogens in large scale slurry treatment plants.....	529
<i>W. Martens, A. Fink, W. Philipp, A. Weber, D. Winter, R. Böhm (Germany).</i>	
Handling of manure in deep-litter pig houses .....	541
<i>E. Klemola, S. Malkki (Finland).</i>	
<b>Chairman's Summary of Part 5</b> .....	549
<b><u>List of participants</u></b> .....	551



## Preface

The 8th International Conference of the FAO ESCORENA Recycling of Agricultural Municipal and Industrial Residues in Agriculture Network (RAMIRAN, formerly the Animal Waste Management Network), was held in Rennes, France from 26 to 29 May 1998. The Conference gathered nearly 150 delegates representing more than 26 countries. Colleagues from all European countries, Japan, Canada, USA, Russia and Chile were present in Rennes.

The FAO European Cooperative Research Network on Animal Waste Management was formed in 1976. The principal activity of the Network is for members to exchange research information and to prioritise work topics, which are then undertaken by expert groups. The need to change the direction and name of the Network to RAMIRAN, was agreed at the last Network meeting in Godollo, Hungary in 1996. After 20 years of focusing on animal wastes, it is now necessary to include municipal and industrial wastes as these are increasingly spread on land and are also the cause of environmental pollution. Animal wastes remains a significant component of the Network's activities but would be considered in a more integrated manner with other wastes which have similar benefits and problems when spread on land.

The theme of the Conference was **Management Strategies for Organic Waste Use in Agriculture** and the Conference was divided into five sessions:

- Management strategies for organic waste use in agriculture
- Agronomic value of organic wastes
- Measurement, modelling and control of gaseous emissions
- Processing and handling of wastes
- Environmental impacts

During these session, 43 papers were presented, including four invited papers (C.H. Burton, J C Fardeau, J-M. Merillot and B.F. Pain). These papers are published in this book. In addition, 50 poster papers were displayed and for each a short oral presentation was allowed.

The Conference confirmed the importance of the ad hoc expert groups as the focus of Network activities between meetings. Progress on their activities will be reported at a workshop planned for 2000 to be held at the Institute of Agricultural Engineering, Milan, Italy. It is planned to hold the 9th major meeting in 2002, which will probably be hosted by the Research Institute of Experimental Veterinary Medicine at Kosice, Slovakia.

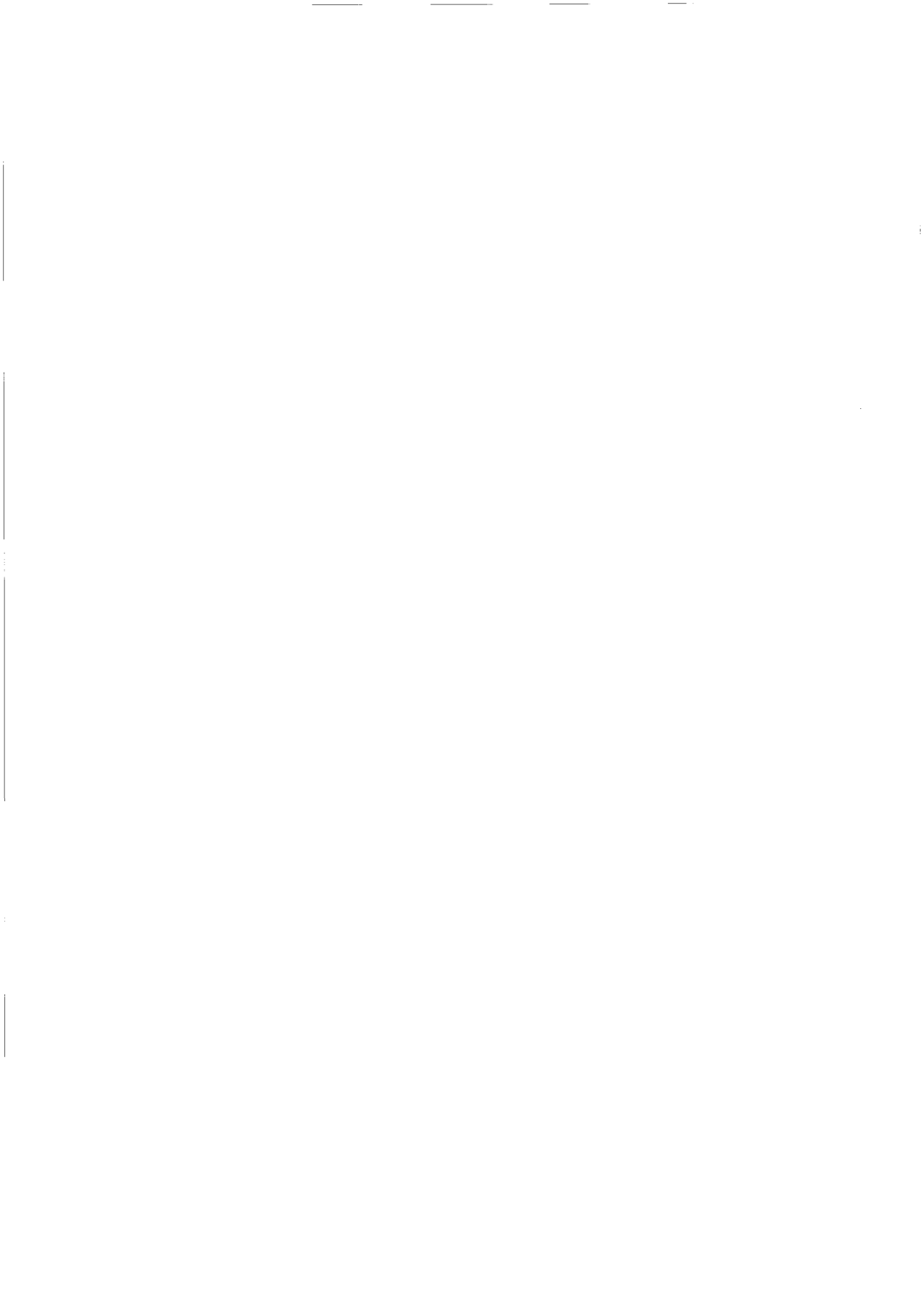

## **Part 1**

### **Management strategies for organic waste use in agriculture.**

**Chairman : J.E. Hall (UK)**

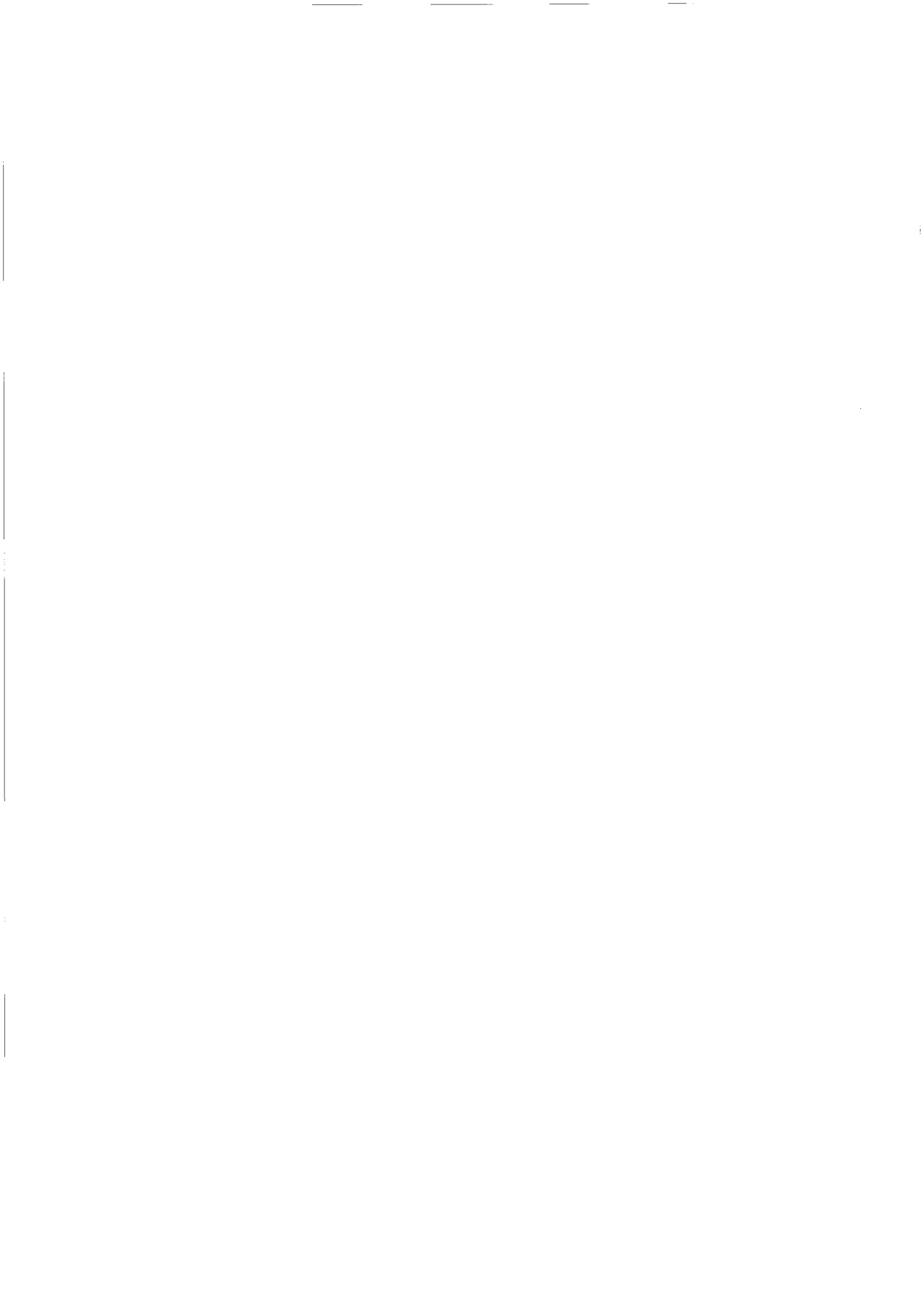

# **Management strategies related to legislative, economic, agronomic and environmental impact of organic wastes.**

## ***Invited Paper***

*Stratégies de gestion des déchets organiques prenant en considération leur impact législatif, économique, agronomique et environnemental.*

### **Jean-Marc Mérillot**

Head of Agriculture and Food Department.

French Agency For Environment And Energy Management, Ademe.

Centre d'Angers. 2, square La Fayette. BP 406. 49004 Angers Cedex 01. France

E-mail : jean-marc.merillot@ademe.fr

### **Abstract**

*As a result of scientific studies and public awareness, environmental protection is now recognized as one of the basic state policies. Strategies management of anthropic activities must, more than ever, take in account not only the environmental legislation corpus, but the concepts and principles that are used to build the public policies. Most of the times, it considers also economical and financial procedures (taxes and grants) and technical tools analysis (systemic analysis and flows balances). Agriculture is highly concerned because of its natural relations to environment and also because of its weight as a production / consumption chain.*

*In most cases, spreading is used for soil restitution of nutrients but with unbalanced flows resulting in environmental impacts. It is obvious that territorial regulation of a « back to soil strategy » must be built on the aptitudes of :*

- *soils to be amended,*
- *crops to be fertilized,*
- *farms to gain profit,*
- *neighbours to agree,*
- *natural areas and ressources to be protected and exploited,*
- *.....*

*When considering each elementary flow, the questions are : what kind of natural cycle is pertinent for a specific flow ? Where and how is it stored in nature ? The answer is different for carbon, nitrogen or phosphorus.*



## Résumé

Devant les résultats d'études scientifiques et face à la demande du public, la protection de l'environnement est maintenant reconnue comme une des politiques publiques des états.

Les stratégies de gestion des activités humaines doivent de plus en plus prendre en compte non seulement le corpus juridique et réglementaire de l'environnement mais aussi les concepts et principes sur lesquels sont construites les politiques publiques. Très souvent, elles intègrent aussi des procédures économiques et financières (taxes et subventions) et s'appuient sur des outils techniques (bilans et analyse systémique). L'agriculture est hautement concernée, par ses relations naturelles à l'environnement, mais aussi par son poids dans la chaîne de production / consommation.

L'épandage est une modalité très utilisée mais en raison du déséquilibre des flux, il conduit à des impacts environnementaux. Il est évident qu'une stratégie de retour au sol doit être basée sur l'aptitude :

- des sols à être amendés,
- des cultures à être fertilisées,
- des exploitations à être rentables,
- du voisinage à être d'accord,
- des zones et ressources naturelles à être préservées et exploitées,
- .....

Si l'on prend en considération chaque flux élémentaire, les questions qui se posent sont : A quel cycle naturel se rapporte-t-il ? Où et comment est-il stocké dans la nature ? La réponse est différente pour le carbone, l'azote ou le phosphore.

## 1. Introduction

Traditionally, management strategies of manufactured products cover the wide range of technical, economical and social considerations, which have learned to live together more or less quietly. The emergence of environmental considerations is relatively recent and leads to troubles. At this point of our knowledge and practices, we can say that :

- new questions that have to be taken in account are identified
- their solutions are not always correctly implemented
- it is often difficult to organise them into a global problematic
- it is even more difficult to translate them into actions

Applied to waste management, the level of difficulty increases of several points, because waste management is, more than other subjects, a conflict area. Further if you add "organic" to "waste", you again increase difficulty because of the complexity of the organic matter, of its reactive potential and of psychological considerations.

A management strategy results of the answers to the following questions :

- What is ideally wishful ? considering the global context
- What is socially acceptable ? considering the present situation
- What is readily feasible ? considering my specific position

These questions must be asked with a frequency depending on the speed of evolution of context, situation and position. However, this evolution is rather rapid because we actually live a period of construction under uncertainties. It means that the questions related to organic waste management must be answered through a prospective analysis, and with a proactive management policy as strategy means that you want to anticipate, to predetermine events and not to stay running after them.

So, the first point is to review the main environmental policies, to analyse their conception and development mechanisms in order to find how they can change in the next future. The second point is to detail the role of waste management policies and systems inside the range of environmental policies, and finally the third point is to describe the possible strategies for organic wastes. I will conclude on the future of the "back to soil" strategy applied to all kind of wastes.

## **2. The place and role of environmental policies**

Maybe, the second part of our finishing century will stay in memories as the emerging period for environmental public policies. And maybe that future generations will find at least funny or completely crazy our polemic debates and our environment protection programs. But, the fact is that each state is building progressively its environmental policies through :

- the organisation of public services for control and incitation
- the development of a legislative corpus
- the modification of the existing economical rules

The role and respective weight of this different parts varies a lot from state to state resulting in more or less "hard" or "soft" regulation policies.

These policies answer to a social demand, as the public opinion has been aware of environmental impacts through scientific works. Aiming to modify our economical development conditions, basically responsible of environmental problems, it is not surprising that they use of financial mechanisms in order to change the value of things, activities and products.

If we look for details on environmental policies, we must consider on one hand the concepts, principles and tools on which they rely and on the other hand the different fields they cover and the way it is co-ordinated.

The concepts, principles and tools can be related to their rationale :

- economical changes	to	polluter/payer principle
- global public policies	to	sustainable development concept
- scientific approaches	to	systemic analysis
- engineering	to	best available technologies strategies
- ecological ideal	to	nature protection strategies

Environmental policies cover a wide range of problems. It results in specific thematic subpolicies, which can be gathered into groups :

- Natural Resources Quality Preservation (air, soils and water)
- "Wild" Nature Protection (biodiversity, protected areas, species in danger...)
- Production Activities Regulation (emissions regulation and waste treatment)

The third one is often the result of the others which give the background to assess the field and level of regulations.

Agriculture is highly concerned with environmental policies, because of its natural relations to nature. It is surrounded by :

- elementary fluxes and geo/biocyclus
- space occupation and landscapes
- quality of its own natural resources
- wild life versus its domestication processes (fauna and flora)

The main problems with agriculture is that :

1. local impacts are the result of a collective behaviour. So the corrective actions must also be collective
2. agriculture covers a wide range of activities, and two main levels of production, e.g. vegetable growing and animal feeding, which have

significant differences considering their respective environmental impacts.

3. production systems for a specific activity are also widely different, depending on many parameters, a part of them are determined by the natural local context.

Agriculture is also involved, as a primary activity, in an important production/consumption chain : the food chain. Specific tools have been developed to analyse the impacts of products through their production chain. Life Cycle Analysis is a well known one. It considers that quality requirements and environmental production conditions are more and more imposed to producers as a feed-back requirement of consumer behaviours. Applied to primary agriculture productions, the problem with such tools is to correctly integrate all the local impacts most of them depending of conditions or practices inside the system and then of the hypothesis that are used.

Another common specificity of the different production steps of this chain is the co-production of organic wastes :

- crops residues
- animal slurries and manure
- agro food organic wastes and by-products
- the organic wastes or fraction of wastes produced by shops, restaurants, and finally household
- at the far end, the organic wastes coming from sewage treatments

All these wastes are involved in a specific management system based on biological processes through animal feeding, biodegradation and new vegetable organic carbon fixation

Following this organic chain, we can notice that generally :

- the production of organic wastes decreases from agriculture to food industries and then to household
- the organic purity decreases also, either by mixing with other wastes or by contamination
- the financial capacity increases

When trying to solve environmental local impacts, the first problem is to define the territorial system and its boundaries. For water pollution problems, it is relatively easy. But, for air pollution, it can be more difficult. Another problem is to determine the respective responsibilities and also to find the solidarity between activities on which can be built action plans. Concerning local space management, there are two main competitors involved in land uses responsibilities : agriculture (cropping) as an

exploitation activity and municipalities as a public administrative regulation level. Manufactories and shops are more concerned with product exchanges (transport of goods, of energy, water resources...) and then with territorial equipment and networks. The corresponding public administrative levels are regional or national.

To achieve this description of environmental problems and strategies, let's have a look on the systemic analysis method. As it comes from physical and chemical principles, it has been developed to assess the impacts of physical and chemical fluxes in and out of a specific system, a production system for instance. But, the reasons of the present situation are not physical or chemical. It is more and more important to take in account for the same system :

- social and economical flows (employment, costs, added value...), which can be easily done
- psychological and cultural flows, which is a little bit more difficult

It is important because the problem of environmental impacts of anthropic activities, which is as old as humanity, needs a negotiated political response and not only a scientific explanation. Maybe, we can find here the reasons of the troubles produced by environmental considerations when applied to social, economical and technical systems.

### **3. Waste management policies**

Among the different specific environmental policies, one is dedicated to waste management. Its role is to develop an intermediate eco-industrial activity which avoid the direct contact between raw rejections (sewage, gases, solid wastes) and the environment. The waste management system takes in account :

- primary wastes from production/consumption chains including used packaging, by-products...
- secondary wastes from treatment of rejections as sewage sludge, flying ashes...

Any waste management system relies on :

- Prevention including avoided productions and improved quality of wastes
- Re-use and recycling of wastes
- Storage in landfills or salt mines, with graduate levels of insulation depending on the wastes danger potential

The system is limited and then determine by the two main points that are Prevention and Landfilling. The problem with prevention is to agree on what has to be prevented : pollution, costs, landfilling, transport... The problem with landfilling

depends on the role it plays in the system. It can be only a final storage equipment for treated wastes or a treatment step, something like an outdoor reactor.

The waste system is mainly defined by the pressure that is made on landfilling through its legal, technical and economical obligations, comparatively to the same kind of obligations on the other possibilities. The aim of waste re-uses is not only to avoid environmental damages from waste disposal, but also to decrease the exploitation of natural resources through recycling. As it is generally not economically profitable to recycle, taxes and financial mechanisms have been developed mainly to charge the consumer and not the citizen.

As the waste treatment activity can produce more pollution than avoided, the waste treatment system must be a clean one. Most of the time, specific emission levels are decided for wastes treatment plants and specific quality composition for waste derived products.

Re-use of waste can be done through three main strategies :

- an industrial recycling/re-use strategy
- a "back to soil" strategy
- an energy production strategy

Each waste strategy can be done by different ways. On one hand, it can integrate industrial cycles, as a "secondary raw" matter, for instance glass or cardboard recycling or industrial organic fertilisers production for organic wastes. At the opposite, less valuable wastes are managed through a territorial organisation of treatments plants, with different space levels as for "Russian puppets". These plants feed proximity utilisation (through networks or local markets).

#### **4. Organic wastes management**

The recycling of organic wastes back to the food chain can be done at different steps of this chain. For instance, animal blood can be used for human food, for animal feeding or for crops fertilisation. It seems natural that organic wastes come back to the food chain, but only as far as it is acceptable, I mean safe and not shocking. But, organic matter can also be used for energy production through digestion or combustion or cogeneration, as a gaseous, liquid or solid fuel, which represent a lot of different possibilities. If lignocellulotic, it can also be used in material recycling, and so on.

The problem of the best solution with organic wastes management covers three main considerations.

First, the complex composition of organic matter, if we consider all the elements, leads to a lot of environmental questions about the most pertinent way to manage the corresponding fluxes. Is nitrogen better in air as ammonia than in water as nitrates ? And what about soil accumulation of trace elements ? Is phosphorus the best target element for organic wastes spreading ?...

Secondly, organic matter is generally very "reactive", I mean potentially source of reactions (as biodegradation, volatilisation, toxicity, ecotoxicity...) depending on its environmental fate. It leads to two kinds of consequences : pollution problems, of course, but also treatment problems as whatever the process you choose, it has adverse effects.

Third, organic wastes can have a high content of water with and consequently, the fate of this water flow must be considered. But, the main point with this associate water is that the alternative strategy is not a solid waste one but a sewage treatment one.

Up to now, most of the territorial organic waste management systems include :

- a "back to soil" basic strategy, through spreading of more or less treated (denitrified, digested, composted, limed...) products. The limits of this basic option come from crops and soils needs and from environmental policies based on nitrogen or phosphorus loads. The adequate territorial level is the local agriculture area. It is relevant for the most aqueous organic wastes including a wide part of soluble elements. The solid wastes or the extracted solid part of wastes can also be managed with the same strategy but at a larger space scale.
- an energy strategy based on combustion or incineration in local supplying energy plants. It works pretty well for dry lignocellulotic wastes and can be used for the excess solid part of wet organic wastes. The good scale covers several municipal territories depending on the local activity pressure and the energy corresponding networks. Anaerobic digestion can supply energy but remains a biological strategy as the final digested products is mainly spread on lands.
- finally, landfilling is still widely practised. But, the future of organic waste landfilling is under discussion and most of environmental policies aim to reduce or ban it. Direct organic wastes landfilling needs methane recovery and, if profitable, utilisation.

## 5. A biological management strategy for organic wastes

What will happen in the next future ?

There is, nowadays, a great problem of acceptability of spreadings, for municipal sewage sludges because of health risks and of the bad image of the product, which applies also to animal slurries because of odour and excessive spreadings.

In order to stop a slow decline of spreadings, the ADEME works on the concept of biological management of wastes. This concept covers all the "back to soil" possibilities but places life and biological processes at the heart of the strategy, as the main decision parameters to regulate this strategy. Then, it must be a demand driven strategy, highly determined by quality requirements.

A programme has been developed on this concept, based on three complementary fields :

- research and development to reduce uncertainties and to improve quality
- pilot sites to work on genuine practices and figures, and to know what is needed and what is effective
- information system for communication and references

To be sure to forget nothing to describe the rules and laws of this strategy, seven "points of view" are needed :

- a) image, communication and social acceptability
- b) legislation , contracts and standards
- c) quality management and training
- d) economical and financial conditions
- e) processing, logistics and organisation
- f) agricultural integration and results
- g) environmental impacts assessment

The aim of this programme is to determine the future conditions of development of the "back to soil" recycling strategy, safety conditions of course but also and mainly its contribution to our future sustainable development.

Another key for future is our ability to develop integrated territorial strategies for all the different sources and kind of organic wastes. We know that the resulting systems will use more or less of each basic management possibilities, landfilling, energy production, fertilization, animal feeding, industrial recycling... depending on local and actual conditions. The co-treatment of different organic wastes is already possible and has been widely demonstrated. But, the genuine co-management has to face many resistance, and first the one which lays in minds reducing our point of view to what happens or not in our backyard.



## 6. References

**Burton C.H., Beck J., Bloxham P.F., Derikx P.J.L., Martinez J., (eds) 1997.** "Manure Management -Treatment Strategies for Sustainable Agriculture" Silsoe Research Institute, Wrest Park, Silsoe Bedford, UK. 181 pp.

**Parfait G., Martinez J., Burton C.H. (eds) 1996 .** "Animal Manure and Environment in Europe" (In French and English) Ingénieries-EAT - Special Issue, Cemagref, Antony, Paris. 200 pp.

**Ademe - Ministère de l'Agriculture et de la Pêche . 1997 .** "Interactions entre Agriculture et Environnement - Quels outils de diagnostic ?" . Actes du colloque du 2 avril 1997.

## **Developing a decision support system for manure management**

*Développement d'un système d'aide à la décision  
pour la gestion des déjections animales.*

### **M.J. Goss**

Centre for Land and Water Stewardship  
University of Guelph. N1G 2W1. Guelph,  
Ontario, Canada

E-mail : mgoss@lrs.uoguelph.ca

### **D.P. Stonehouse**

Agricultural Economics and Business  
University of Guelph. N1G 2W1. Guelph,  
Ontario, Canada

### **J.R. Ogilvie**

School of Engineering  
University of Guelph. N1G 2W1.  
Guelph, Ontario, Canada

## **Abstract**

*In 1991 the University of Guelph formed a group to bring together representatives of all the stakeholders concerned about manure management. The deliberations of the group, together with views of farmers and advisors obtained at focus workshops across Ontario, resulted in a report summarizing the state of the art in manure management. The report identified key areas for research and development. Many of the proposals for research were included in the Federal-Provincial Green Plan initiative. The recommendation of most concern to the industry was the integration of available information into a form that could guide farmers in improving manure management.*

*The University formed a team to develop a computer-based decision support system (DSS), the first version of which was completed in 1997. The DSS deals with manure management from the feed input, manure release and handling in the barn, storage, field application, transformation in the soil, to incorporation of nutrients in crops.. The information on nutrient loss is used to estimate off-farm economic impact of the manure system. The DSS also features a weighted rating system to compare different systems.*

## **Résumé**

En 1991, l'Université de Guelph a réuni un groupe de travail comprenant l'ensemble des acteurs concernés par la gestion des déjections animales. Les travaux de ce groupe ainsi que les contributions d'agriculteurs et de professionnels ont abouti à la préparation d'un rapport contenant l'état de l'art sur la gestion des déjections. Plusieurs propositions de recherches furent par la suite dans le contrat de plan « Vert » Etat Fédéral - Province. L'une des principales recommandations était le besoin d'intégrer l'information disponible sous une forme utile pour guider

les éleveurs dans leur choix de gestion des déjections. L'Université a alors rassemblé une équipe pluridisciplinaire pour développer un système d'aide à la décision, dont la première version fut présentée en 1997. Ce système aborde la gestion des déjections depuis l'alimentation, la production de déjections et la gestion dans le bâtiment, au cours du stockage ainsi que l'épandage, la transformation dans le sol et l'incorporation par les plantes. Les informations sur les pertes d'éléments sont utilisées pour calculer le coût et l'impact économique du système.

## 1. Introduction

There has been increasing concern about the impact of animal manure on the wider environment<sup>1</sup>, and this has resulted in constraints to the growth or absolute size of animal production in different regions. In 1991 the University of Guelph formed a group that brought together representatives of all the stakeholders concerned about manure management. Their deliberations, together with views of farmers and advisors obtained at focus workshops across Ontario, resulted in a report summarizing the state of the art in manure management<sup>2</sup>. The workshops highlighted the need to integrate information related to the feed and supply of water to confined animals, the design of barns and the associated storage facilities for manure, opportunities for processing manure, transportation of manure, the land application and utilization of manure in crop production, and the protection of the environment from odour and excess nutrients (including carbon). Within each of these topics, the economic aspects, educational needs, and the development of an understanding of the processes involved, were identified as important goals that would allow the farming community to meet its challenges. The University of Guelph group established for Ontario a priority for research and extension related to manure. A total of twelve priority areas was identified. The first two were: i) develop extension packages to assist farmers in making more effective use of nutrients in manure; ii) establish a research program involving engineers, animal scientists, agronomists, soil scientists and economists to develop a comprehensive framework by which alternative manure management systems can be compared. The University, through its partnership for agricultural research and development with the provincial agricultural ministry (Ontario Ministry of Agriculture, Food and Rural Affairs-OMAFRA), formed a team to develop a computer-based decision support system (DSS) that would encompass both priority areas. Most of the other priority areas for research were included in the Canada-Ontario Green Plan initiative (see <http://res.agr.ca/lond/gp/gphompag.html>). This paper describes the integration of research, development and extension in the process of constructing the DSS, and highlights the structure of the program that was completed in 1997.

## 2. Procedures

The team of scientists was selected according to the research recommendation. In addition, researchers and extension workers from other public sector organizations and from private consultancies were invited to attend team meetings. An email discussion platform was set up as a list-serve address. Subsequently a web site has been established (see <http://www.oac.uoguelph.ca/ManSys/>). Two members of the team agreed to act as project co-ordinators.

The first action point for the team was to undertake a literature review pertinent to the needs of the envisaged DSS. This provided an assessment of the significance that gaps in information would have for the reliability and precision of the DSS. The material was drawn from North America, Europe, Asia and Australasia. This review was published as a book<sup>3</sup> comprising nine chapters, although due to the overwhelming volumes of literature available and the need to work to a tight time schedule, and considerable selectivity was inevitable. Individuals provided an overview of alternative DSS's for manure management. It was concluded that despite the large number of existing software packages there was still a need for a comprehensive DSS dealing with manure handling and nutrient management.<sup>4</sup> One important factor was that improvements in computer hardware and software have made complex operations, until recently only possible on mainframes, feasible on home-computers.

Impacts of animal diet on the nutrient content of manure were reviewed. One aspect that needed further research was the estimation of the quality of dairy manure based on feed input.<sup>5</sup> Various models were examined that predict the excretion of N and P by different age classes of pigs. From these models the nutrient content of manure on an individual farm could be calculated. It was concluded that more research was necessary to assess the consequences of phase feeding and amino acid supplements for manure quality.<sup>6</sup> After excretion, changes take place in manure composition in the barn and during longer-term storage prior to field application. Significant gaps were identified in knowledge of the aerobic and anaerobic processes taking place in solid manure piles, and knowledge of the influence of depth below the surface of solid piles or liquid storages on composition.<sup>7</sup> The pH of manure is important for ammonia (NH<sub>3</sub>) loss, but predicting the value at the surface of liquid manure was a major limitation in estimating NH<sub>3</sub> volatilization. The capability to predict N<sub>2</sub>O loss from manure was also recognised as a significant gap in knowledge.<sup>7</sup> The gaseous emissions from swine and dairy cattle farms are affected by the design of livestock barns, manure storage, and the field application of manure. The proportion of the total emission originating in the barn was identified as requiring research, so too was the amount of the emission that was redeposited locally.<sup>8</sup> The interrelationship between the production and emission of CO<sub>2</sub>, CH<sub>4</sub>, N<sub>2</sub>O and NO was seen as an important area that required more work.

In his review of recent research on crop response to manure nutrients, especially nitrogen (N), phosphorus (P) and potassium (K), Beauchamp<sup>9</sup> identified that the following aspects of manure N availability required further research:

- improve methods to predict manure N availability with particular reference to the organic N fraction from monogastric and ruminant livestock;
- improve understanding of the roles of ammoniacal N and beddings in relation to net immobilization and net mineralization of N in soil following manure application to land;
- clarify crop responses to N in fall-applied manure compared with spring-applied manure;
- develop a soil N test that reflects the availability of the organic N following manure application;
- clarify the impact of animal diet on availability of manure P relative to fertilizer P, particularly with respect to differences between monogastric and ruminant livestock

It was concluded that research on manure phosphorus was generally of lesser priority than that on manure N. Nevertheless the availability of manure P deserved attention.

An assessment of the factors associated with the transport of N, P and micro-organisms into surface and groundwater indicated that prediction of the contribution from preferential flow to the transport of  $\text{NO}_3^-$  and bacteria was necessary. It also indicated that the ability to predict transport of bacteria to ground water was limited.<sup>10</sup>

Although on-farm economics of manure management has been studied extensively, information was needed to allow a cost-benefit analysis for alternative management systems.<sup>11</sup> Alternative methodologies were identified as needed for evaluating the economic value of environmental damages caused by contamination stemming from manure.<sup>12</sup>

The team also decided to adapt existing programs wherever possible rather than always create entirely new code. Research was then focussed on establishing appropriate provincial databases for input parameters and rate constants of processes.

A call for research proposals to cover identified issues related to manure management was issued in 1996. This included work on the release of nitrogenous gases from manure in storage and after application to arable fields, the development of improved method to predict availability of N in manure, and the evaluation of contamination of water resources from agriculture, including animal production units. Specific contracts were placed to develop models to cover the transport of gases from livestock barns and manure storages, provide information

on the transport of micro-organisms from manure to ground water after land application, and develop a cost-benefit database for different components of manure handling systems.

Information from the projects on manure funded under the Canada-Ontario Green Plan initiative was also made available for development of the DSS.

To encourage industry participation in the development of the DSS and obtain basic information on the manure handling systems in use in Ontario, the Dairy Farmers of Ontario and Ontario Pork, which together represent about 14,000 of the producers in the province, were asked to support a survey of their members. Producers were asked about the physical plant used for manure management, and about their use of computers. Of the dairy farmers who responded to the survey, 34% said they would consider using a computerized DSS to aid their manure management. The comparable number for hog farmers was 42%. This provided adequate assurance that development of a computerized system would be an appropriate goal.

### **3. Development of the software**

The construction of the DSS was based on an earlier program (MCLONE - **M**anure, **C**ost, **L**abour, **O** odour, **N**utrients and **E**nvironmental) developed for swine operations.<sup>13</sup> Fleming's program was written in Turbo Prolog and had a DOS window system of presentation. This software had been upgraded to use inputs from a mouse control.<sup>14</sup> The new program, MCLONE3, was developed by Ma<sup>15</sup> to bring the DOS program into a modern computer language. KnowledgePro++ (Knowledge Garden, Inc., Lake Worth, FL) was chosen to use a Windows™ based expert system presentation.

MCLONE3 uses an object-oriented format within KnowledgePro. Through a set of screens users may provide their own inputs, save the input data files and run the program again. There is a separation of program and data. More sensitive data such as costs are put in separate files so that the program does not have to be recompiled when updating. With KnowledgePro the hypertext feature is built in and used for explanations of the 'why' and 'how'. That is, hypertext provides the user with a response as to why the question is being asked. Similarly hypertext is used to explain how the program will arrive at an answer. A certainty factor calculation has been added although the user does not have the ability to change these values. That is, the certainty of the answers is judged within the program based on expert knowledge about the topic. The certainty value is reported to the user along with the results in each section.

#### 4. Key features of the DSS

Manure production is normally based on previously available data on output for the number, size and type of dairy and swine animals<sup>16</sup> (Table 1). Another method of determining swine manure production has been added, called the detailed method for estimation, in which feed intake is used to determine nutrient and mass output.<sup>6</sup> In this approach, feed that goes to waste is assumed to end in the manure. N in feed is assumed to be in crude protein, and will have a digestibility that depends on the age of the animals. Undigested protein contributes to the faeces N load. Digested protein contributes to an increase in the lean yield of the animals or is excreted in urine. Provision is made to take account of changes in the nutrient content of manure due to feed additives, such as phytase and amino acids. The relative proportion following the urine pathway depends on the age and size of the animal. For liquid storages, summer and winter precipitation and evaporation for the various regions of Ontario are taken into account to estimate manure volume.

To account for the additional water entering the manure in the barn, different inputs to the program are required depending on the animal type. For dairy cows the user inputs the total amount of waste water produced per day. For swine farms, the user inputs additional water added expressed as a percentage of manure produced for feeders, starters and breeders. Input for precipitation can be provided by the user, and for net precipitation, summer evaporation is made equal to precipitation. Winter evaporation (November-April) is based on an estimate of 60% of the precipitation being lost by evaporation from an open manure pit. The final volume of manure is then given by the sum of the volume excreted, the volume of wash water, and the net precipitation.

	Manure mass kg/day	N kg/day	P kg/day	K kg / day
Dairy cows	86	0.45	0.094	0.29
Dairy calves	62	0.27	0.066	0.28
Swine	84	0.52	0.180	0.29

*Table 1.  
Manure production of dairy and swine (per 1000 kg of body mass)*

Field application takes account of the maximum hydraulic loading possible without liquid manure running-off the soil surface. The recommended application rate allows either nitrogen (N) or phosphorus (P) limitations depending on the soil test results or other environmental factors. Users can also set their preferred rate. Crop uptake<sup>18</sup> and ammonia volatilization remove N from the soil, while the sources are manure-N, any applied fertilizer-N, and residual N from previous manure. Credit is given for manure applied, or leguminous crops grown, in the previous two years.

N loss during each stage of handling is monitored by the DSS and finally reported at the end of the program. The loss values were updated from the latest research findings. They include such modifiers as losses based on type of barn, e.g., open

dairy housing; losses from storage taking account of loading method, loading rate and wind speed; losses during field application, where the rate of N loss reflects inefficiencies in the method of spreading, e.g., irrigation, and from denitrification when manure is injected. After surface spreading the amounts of ammonia volatilization varies depending on the length of time before manure is incorporated.

Comparing the N retained on the farm with the total amount excreted by the animals provides one means by which the environmental impact of a manure management system is assessed. Advice on protecting water courses from P contamination following manure application is also included in the DSS. A phosphorus index for Ontario (P Index) was developed based on a program developed in Delaware.<sup>17</sup> Essentially the index combines inherent properties of the soil and the field with management factors (Table 2). This index provided a further limitation to manure spreading on fields susceptible to erosion. Phosphorus not taken up by crops builds up in the soil and is flagged at 60 mg kg<sup>-1</sup>. Above that limit, application of manure is restricted to that removed in the harvested crop. Potential environmental impact due to P derived from manure is then determined from the soil P test, the amount of P applied relative to crop requirements, the risk of storages overflowing due to inadequate volume for the number of animals housed or due to the limited windows of opportunity for manure to be spread. The potential pollution rating is given as a function of the sum of the P index value, the risk associated with the application of manure greater than crop requirements, the risk due to storage shortage, and the number of days over which the shortage might occur.

Factor	Assessment	Options for modifying factor
Soil erosion rate	Soil type, slope, ground cover, rainfall	Introduce conservation practices
Soil water management	Run-off, infiltration	Introduce conservation practices
Soil P	Soil test	Adopt nutrient management strategies
P application	Fertilizer rate, manure rate	Ensure sufficient land area for spreading
Method of P application	Equipment adopted	Restrict time that manure is left on the soil surface
Susceptible water body	Distance to water course	-

*Table 2.*

*Factors affecting environmental risks from phosphorus management on farm fields*

The problems of odour from barns and manure storage are dealt with using the minimum separation distance acceptable between these structures and non-farm properties.<sup>18</sup> Odour associated with field application is assumed to be proportional to the loss of ammonia by volatilization associated with this operation.



Data requirements for the DSS model's socioeconomic components are subdivided into those for evaluation of on-farm economics and those associated with the cost of environmental damage. On-farm economics requires information on operating costs (for labour; fuels; equipment - custom hire or rentals -; repairs and maintenance for equipment and machinery), ownership costs (depreciation and opportunity cost interest on capital assets such as manure storage facilities, manure collection and field distribution equipment), and benefits from manure (opportunity cost value of plant nutrients applied to the soil and the value of any soil-productivity enhancements due to organic matter accumulation). The manure management system is treated as modular, and costs are incurred for each system component. Of the operating costs, the user supplies actual costs for equipment, custom hire, and rentals, unit costs for labour and fuels, plus quantity of labour used. Fuel use and maintenance costs are based on ASAE standards.<sup>16</sup> Similarly, for ownership costs, annual amortization is calculated from the ASAE standards equation. Benefits derived from manure are based on opportunity cost value of plant nutrients alone, there being no reliable data source for longer-term soil productivity enhancements; plant nutrient (nitrogen, phosphorus and potassium) quantities are according to laboratory analysis of manure samples at point of field application, and unit values are according to current retail costs of N, P and K in synthetic fertilizer form.

For environmental damage cost assessment, a proxy was used. Attention is focused on social acceptability aspects of manure management. The assumption is made that social acceptability is inversely related to odour emissions and indirectly, to gaseous emissions, and that the contamination of water resources can serve as proxy for environmental damage. Risk assessments related to release of odour from barns, manure storages and during land application, to the release of nitrogenous gases, and to the contamination of water resources due to the leaching of nutrients, are developed for each alternative manure-handling systems using a simple scalar of 1 to 10, 10 for lowest risk and 1 for highest.

The information generated in the potential pollution rating package, the odour rating package, the nutrient rating package, the cost rating package, and labour rating package is brought together in a framework of assessment for the efficiency rating of the whole system.<sup>15</sup> The user can set the relative importance of each of the five aspects to his own situation, with the provision of weighting factors (Fig. 1). The sum of the five values of the weighting factor has to equal 100. This assessment framework allows the user to compare different manure handling systems and evaluate how the weighting of priorities can enhance or affect adversely the efficiency of the manure management.

As far as possible, geographically-local data are used for equipment replacement costs, labour costs and capital borrowing costs, so as to reflect regional conditions.

Otherwise, published secondary sources are used, where available. In many cases, required data are not available in published form, and need to be generated by the manure management team.

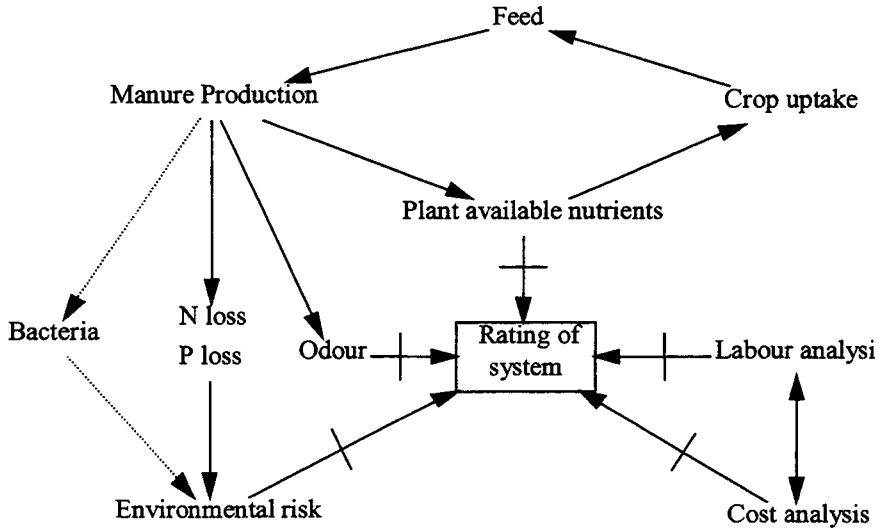

*Fig. 1 Schematic for the DSS - MCLONE3.*

*Note the opportunity to vary the weighting associated with each of the five key areas that are combined in the rating of the system.*

The alpha-test version of the DSS is available for evaluation by downloading from the University of Guelph's manure management team web site (see : <http://www.oac.uoguelph.ca/Mansys/>)

## 5. Conclusions

A comprehensive decision support system for manure management has been developed following an extensive process of consultation and review<sup>20</sup>. During the process, close links have been established between the multi disciplinary team assembled for the task and the dairy and swine industries through the data acquisition process. The importance of public concern for the environment has resulted in the assessment of the manure handling system considering nutrient use efficiency, odour production, and impacts on water resources as well as the labour resources and costs. The user of the DSS can change the relative weighting given to these aspects in comparing different manure management systems.

## 6. References

- <sup>1</sup> **Stonehouse D P** Economic considerations in land application of animal manure. In: Proceedings of National Workshop on Land Application of Animal Manure. D A Leger; N K Patni and S K Ho (Eds). Canadian Agricultural Research Council, Ottawa, Ontario. 1991 85-98.
- <sup>2</sup> **Goss M J; Ogilvie J R; Beauchamp E G; Stonehouse D P; Miller M H; Parris K** *Current State of the Art on Manure/Nutrient Mangement*. Final Report to Agriculture Canada, Contract 01689-2-3920/010XSE. 1993
- <sup>3</sup> **Goss M J; Stonehouse D P; Giraldez J C** (Eds.) *Managing Manure for Dairy and Swine: Towards Developing a Decision Support System*. Centre for Land and Water Stewardship. Guelph, ON. 1996
- <sup>4</sup> **Ogilvie J R; Ma K** Decision support (DSS) for manure systems management. Chapter 1 in Ref. 2
- <sup>5</sup> **Haig P A ; McBride B W** Effect of animal and diet factors on dairy cattle manure quantity and Composition Chapter 2 in Ref 2
- <sup>6</sup> **de Lange C F M** Animal and Feed Factors Determining N and P Excretion with Pig Manure. Chapter 3 in Ref. 2
- <sup>7</sup> **Barry D A J** N and C transformations during long term storage of manure. Chapter 4 in Ref. 2
- <sup>8</sup> **Edwards G C ; Wagner-Riddle C** Environmentally significant gases associated with livestock barns, manure storage and field application of manure. Chapter 5 in Ref. 2
- <sup>9</sup> **Beauchamp E G** Availability of macronutrients to field crops from alternative manure systems Chapter 6 in Ref. 2.
- <sup>10</sup> **Goss M J ; Zwart P D; Kachanoski R G** Transport of nitrogen, phosphorus and disease organisms from manure into surface and groundwater. Chapter 7 in Ref. 2
- <sup>11</sup> **Stonehouse D P ; Giraldez J C** On-farm socio-economics of manure management Chapter 8 in Ref. 2
- <sup>12</sup> **Weersink A** Evaluating environmental damage from animal manure. Chapter 9 in Ref. 2 :
- <sup>13</sup> **Fleming R J** An expert system for the selection/design of swine manure handling methods. Unpublished M.Sc. Thesis. Univ. of Guelph, School of Engineering Guelph, ON. 1988
- <sup>14</sup> **Kortleve W J** Report of research projects at the University of Guelph: a 6 month internship. School of Engineering, Univ. of Guelph, Guelph, ON [Report to Wageningen Agr. University, Wageningen, The Netherlands.] 1992
- <sup>15</sup> **Ma K K Y** MCLONE3: *A Decision Support System for Managing Liquid Dairy and Swine Manure*. Unpublished M.Sc. thesis. University of Guelph, School of Engineering Guelph ON. 1997

- <sup>16</sup> **ASAE** *Manure production and characteristics*. ASAE D384.1, ASAE, St. Joseph, MI 49085 1995
- <sup>17</sup> **Sims J T**. *The Phosphorus Index: A Phosphorus Management Strategy for Delaware's Agricultural Soils*, University of Delaware, Newark, DE. 1996
- <sup>18</sup> **OMAFRA** *Minimum Distance Separation Formulas (MDS I and MDS II)*. Ont. Min of Agr, Food and Rural Affairs, Guelph, ON 1995
- <sup>19</sup> **OMAFRA** *1995-1996 Field Crop Recommendations*. Publication 296. Ont. Min of Agr, Food and Rural Affairs, Guelph, ON 1995
- <sup>20</sup> **Ma K; Ogilvie J R** *MCONE3: A decision support system for management of liquid dairy and swine manure*. In: *Proceedings of the 7<sup>th</sup> International Conference on Computers in Agriculture*, Orlando, Florida, October 28-30, (forthcoming)1998.

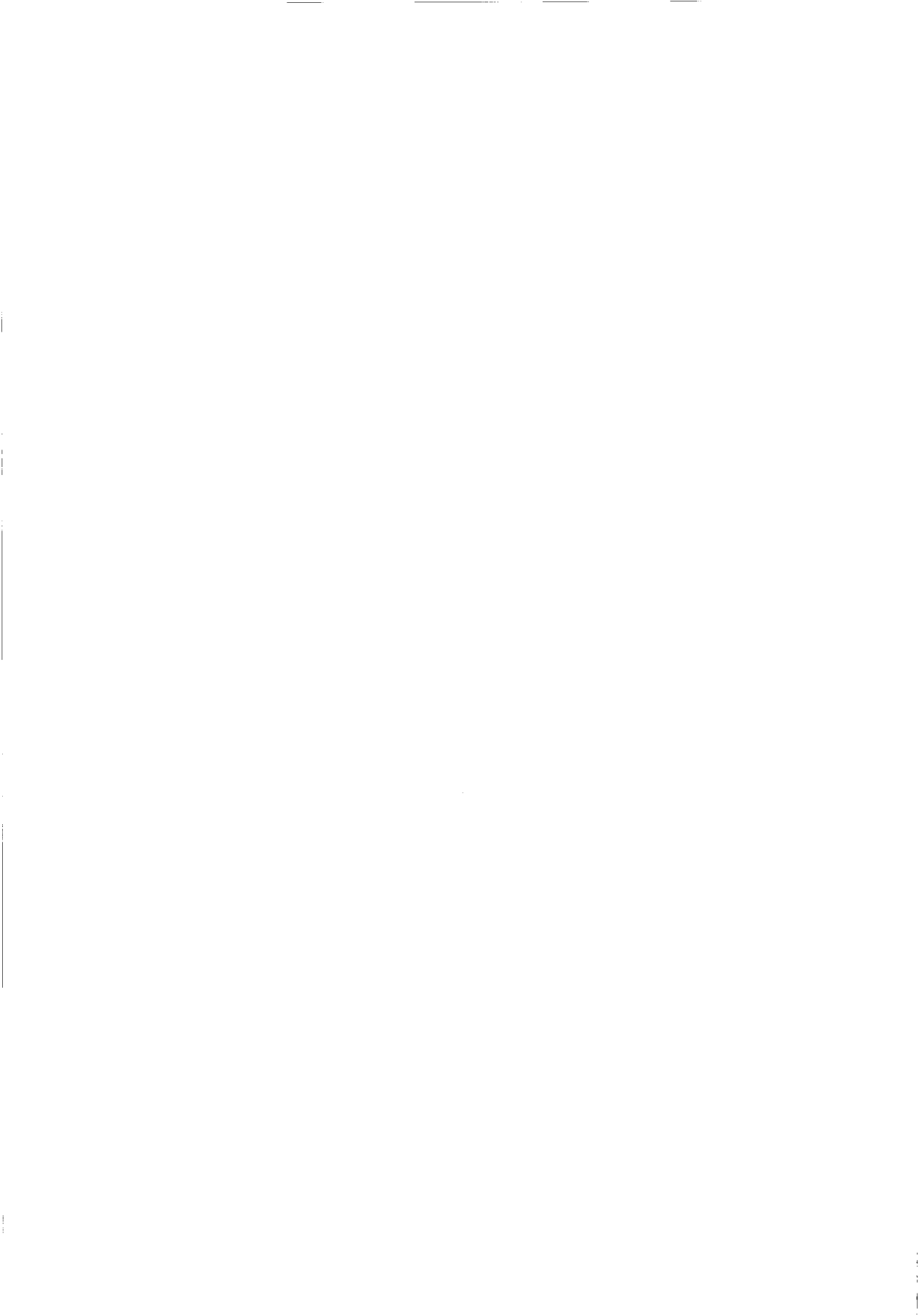

# **SWAMP<sup>1</sup> - Optimising the use of slurry**

*SWAMP - Optimiser l'utilisation du lisier.*

**J.J. Lenehan**

Teagasc, Grange Research Centre,  
Co. Meath, Ireland  
E-mail : [jlenehan@grange.teagasc.ie](mailto:jlenehan@grange.teagasc.ie)

**J. Huijsmans**

IMAG-DLO Wageningen,  
The Netherlands

**G. Provolo**

Istituto di Ingegneria Agraria,  
Milan, Italy.

**T. Cumby**

Silsoe Research Institute,  
Bedfordshire. United Kingdom.

**F. Lorenz**

LUFA, Oldenburg. Germany

**J. Peross**

Algosystems, S.A., Athens, Greece

**M. McGechan**

S.A.C., Edinburgh, United Kingdom.

## **Abstract**

*Collection and storage of farm manures as slurry has become normal practice on intensive livestock farms. This system for manure storage has many advantages including automation of slurry collection, reduced labour requirements and minimal use of bedding materials. Ideally, the slurry should be applied on suitable lands, at application rates which match the nutrient requirements of the crops being grown. This approach will minimise the risk of pollution. Often existing methods of application do not achieve these aims. The slurry is applied at the incorrect rate because the farmer does not know the nutrient content. Even if the nutrient content is known, the type of equipment used may not apply the material evenly. Also different soil types and weather conditions at application will influence the potential for nutrient leakage and associated pollution risks. This recently completed EU funded project - Sustainable Waste Application Management Project (AIR3 CT94-1276) addresses some of the problems associated with utilising slurry and comprises three major research areas :*

- *Management and Risk assessment.*
- *Determining the Nutrient Value of Slurry.*
- *The development of Prototype Application System.*

---

<sup>1</sup> Sustainable Waste Application Management Project.

## Résumé

La collecte et le stockage des effluents d'élevage tels que le lisier sont la pratique courante dans les élevages intensifs. Ce système de stockage des effluents présente de nombreux avantages y compris l'automatisation de la collecte du lisier, une réduction de la main d'oeuvre requise et une utilisation minimale de litières. En principe, pour réduire les risques de pollution, l'épandage du lisier devrait se faire sur des terres qui en ont besoin, selon des doses d'application qui correspondent aux besoins en éléments fertilisants des cultures. Bien souvent, les méthodes d'application existantes ne permettent pas d'atteindre ces objectifs. Les quantités appliquées sont incorrectes parce que l'agriculteur ne connaît pas la teneur en éléments fertilisants du lisier. Même lorsqu'il la connaît, le type de matériel utilisé ne permet pas toujours un épandage régulier. Par ailleurs, le type de sol et les conditions météorologiques au moment de l'application influencent le potentiel de ruissellement des éléments fertilisants et les risques de pollution associés. Ce récent projet européen intitulé SWAMP (projet de gestion de l'application durable des déchets) (AIR3 CT94-1276) a été réalisé avec l'assistance financière de l'Union Européenne (UE). Il visait à résoudre certains problèmes associés à l'utilisation du lisier et se subdivise en trois grands domaines d'étude :

- Gestion et évaluation du risque.
- Détermination de la valeur fertilisante du lisier.
- Développement d'un prototype de système d'application.

## 1. Introduction

For millennia mankind has recognised the importance of recycling organic manures as a nutrient source for crop production (Tunney et al., 1997). However, as production systems have developed there has been a trend towards more specialisation of agricultural activity with an associated reduction in the dependence on organic manure as a nutrient source. The demand for economic systems of food production, the availability of relatively cheap sources of inorganic fertiliser and the development of efficient transport systems for agricultural inputs and products have aided the increased specialisation of production systems (Fluck and Baird, 1980). The collection and storage of farm manures as slurry has become normal practice in many regions. This management system has many associated advantages including the automatic collection of slurry, reduced labour requirements and minimal use of bedding materials. Ideally, the slurry should be applied on suitable lands at application rates which match the nutrient requirement of the crops being grown. This approach will minimise the risk of pollution resulting from the leakage of plant nutrients either to watercourses or the atmosphere (Burton, 1997). For grass based production systems suitable application lands are typically available adjacent to the farm yard. For animal production based entirely on bought in concentrate feed it is more difficult to source suitable spreading sites.

Existing methods of application, e.g. vacuum tankers with splash plates, do not facilitate the efficient utilisation of nutrients in farm slurries (Pain, 1989; Carlson, 1994). The slurry is often applied at the incorrect application rate because the farmer does not know the nutrient content of the material (O'Brice et al., 1992). Even when the nutrient content is known, the spreading device may not apply the slurry evenly. Different soil types and weather conditions at application will influence the potential for subsequent nutrient leakage and associated pollution risks. A recently completed, EU funded project - Sustainable Waste Application Management Project - *SWAMP* (AIR3-CT94-1276) addressed some of the problems associated with utilising slurry and comprised three major research areas:

- (a) Management and Risk Assessment of Slurry Application Operations
- (b) Determining the Nutrient Value of Slurry
- (c) The Development of a Prototype Application System

## **2. Management and Risk Assessment**

The objective of good slurry management is to make maximum use of the nutrients in the material while minimising the risks associated with land application. Many factors must be considered in the decision process for applying slurry including the quantity of material to be spread, soil type, field drainage system, weather conditions, crop type, time of year etc. The *SWAMP* project developed a decision support system using computer modelling to aid the decision-making process. A twin approach was adopted involving two modules - *Environmental Risk Assessment* (ERA) and *Application Decision Support* (ADS). The ERA module provides an assessment of the nutrient losses (and thus pollution risk) associated with a particular slurry application event while the ADS module aims to provide the decision support for the farmer in making the correct day to day management decisions when applying slurry.

### **2.1. Environmental Risk Assessment - ERA**

Nutrient loss mechanisms from a field include surface run-off of whole slurry, macropore flow through the soil of particulate pollutants, leaching of dissolved nutrients to field drains and deep groundwater, ammonia volatilisation and emissions of nitrogen oxides. Nutrient dynamics as considered by the *SWAMP* project are concerned with the loss of phosphorus and nitrogen in surface run-off and the further loss of N in the form of  $\text{NO}_3$  through leaching via field drains or ditches.

The approach adopted to provide the assessment of nutrient loss is to use weather driven simulation models of soil water and nutrient dynamics. These models require site specific historical weather patterns and soil hydrological characteristics and are used to simulate agricultural practices over 10 years of weather data. A statistical analysis of the predictions is then carried out which produces a risk percentage for



each week that surface run-off will occur on a field during the critical period after slurry application. A similar procedure produces modelled yearly estimates of N leaching for each field for various agricultural practices.

A number of simulation models were considered for use in the project. SOIL and the SOILN models (Jansson, 1996; Eckersten et al., 1996) were selected as being the most appropriate (McGechan et al., 1997). The SOIL model is a multi-layer model and it can indicate the soil water content and horizontal movement of water to field drain backfill at different depths, as well as deep percolation, with a range of drainage system options. Work was carried out to calibrate and validate the SOIL model for selected sites in Scotland and Ireland. The validation studies with the model showed reasonable agreement between simulations and measurements for drainflow volumes, soil water content, water table height and surface run-off volumes (Lewis and McGechan, 1998).

A similar approach was used to calibrate and validate the SOILN model for nitrogen dynamics (Wu et al., 1998, Wu and McGechan, 1998). The ERA approach produces information about polluting risks from run-off and about N losses when a soil type, crop, climate and a fertilisation strategy has been defined.

## **2.2. Application Decision Support**

ADS was devised to assist the farmer in developing a successful farm manure management strategy and the module has three main elements :

- nutrient balance to the farm
- strategic field by field scheduling of slurry application (planning)
- tactical field spreading decisions (day to day operation)

The nutrient balance is based on details of livestock types and number, housing, nutrient losses (e.g. treatment or storage), import or export of manure from the farm and crop nutrient requirements. Strategic scheduling takes into account the spreading system available and its related nutrient losses, the amount of organic fertiliser available in relation to crop requirements, the spreading days available depending on location and restrictions on any spreading operation due to legislation. The final output of this section is a field-by-field recommendation on the volumes of slurry to be applied on each field and for each spreading event. It also provides information on the top-up requirements for mineral fertiliser if necessary. The final section aids the farmer in the making of day to day decisions on slurry application taking into account weather conditions and practical farm operational constraints, e.g. work capacity of machines.

### 3. Determining the nutrient value of slurry

Slurry in farm stores typically has a variable nutrient content (O'Brice et al., 1992) which makes it difficult to efficiently use in a planned fertilisation programme for crop production. The variable nutrient content of slurry is a result of the variation in animal type, diet composition, dilution with water etc. Further variation from the mean nutrient content within individual stores results from the stratification of the material over time, e.g. surface crust formation in cattle slurry and settlement of solids in pig slurry.

Four methods of measuring or estimating the nutrient content of slurries were considered as part of the project and details are outlined in Table 1. The estimation methods are considered useful for long-term planning of application strategies, e.g. while the measuring methods are more applicable for use with actual application operations.

Measuring Methods	Estimation Methods
Rapid Laboratory	MESPRO Model
In-Line Sensor	Balance Approach

*Table 1.  
Methods examined for determining nutrient value*

#### 3.1. Rapid Laboratory Analysis

Laboratory analysis of slurry samples requires the collection of a sample which is representative of the total amount of manure. Agitation before sampling is essential. The ability to rapidly produce a result for the farmer is necessary for practical purposes. The Rapid Laboratory Analysis approach aimed to develop and test a standard protocol for measuring the nutrient content of slurry which could be adopted in all laboratories. IMAG coordinated the work on this development. An advantage of the new method is that only one digestion step is needed to obtain a solution in which total nitrogen, total phosphorus and total potassium can be measured with methods available in most laboratories. A successful ring test was carried out in participating countries to validate the accuracy of the method (Derikx and Beurskens, 1997). Figure 1 gives a schematic presentation of the procedure used.

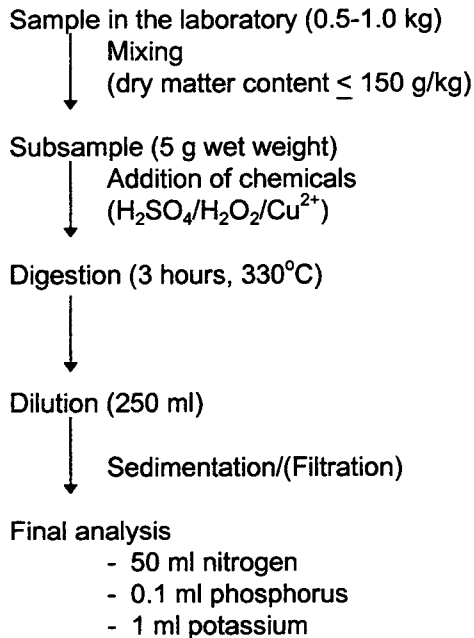

Figure 1.  
Schematic pathway of the combined determination of N, P and K  
of manure samples

### 3.2. In-Line Sensor

The development of an on tanker in-line nutrient sensing system would remove the potential error resulting from the sampling operation from stores when taking slurry samples for analysis as the nutrient content of each tanker load of material could be measured. Another major advantage of the technique is that the results are immediately available for use.

Previous research has shown that correlations exist between the nutrient content of slurries and total solids or bulk density (Piccinni and Bortone, 1991; Tunney and Bertrand, 1989). These approaches have utilised simple physical measurements (e.g. hydrometers) to yield predictions of phosphorus and total nitrogen. In general, these methods are inconvenient for frequent use. The work programme undertaken in the *SWAMP* project and directed by Silsoe Research Institute involved the development of an in-line sensor for slurry using a number commercially available physical and chemical sensors. Initially, a small scale, *in situ* device was constructed and tested on slurries in the UK, Italy, Germany and Ireland. Following analysis of the data a field scale unit was constructed and fitted to a prototype

tanker. The unit was tested with a range of cattle and pig slurries in the UK and Ireland. A single card computer was programmed to convert the individual physical and chemical measurements to values of nutrients available in the slurry, which were displayed in the tractor cab. The sensing system was tested with 18 different slurry samples. In each case the slurry was recirculated through the sensing system until stable readings of ammoniacal nitrogen (AN), phosphorus (P) and potassium (K) were recorded. A sample of each slurry was taken for laboratory analysis of AN, P and K. The predicted values from the in-line sensing system were compared with laboratory results.

The sensing system gave a good prediction of the ammoniacal nitrogen for all slurries tested, with a coefficient of determination ( $r^2$ ) of 0.92. The standard error was  $0.38 \text{ kg/m}^3$  in a range of  $0.63$  to  $5.29 \text{ kg/m}^3$  (i.e.  $< + 10\%$ ). The results for phosphorus were disappointing ( $r^2 = 0.44$ ), based on the full set of slurries tested. However, separate inspection of the results for UK and Irish pig slurries showed a better prediction ( $r^2 = 0.99$  and  $0.82$ , respectively). The standard errors were  $0.02 \text{ kg/m}^3$  in a range of  $0.24$  to  $1.73 \text{ kg/m}^3$  (i.e.  $< + 10\%$ ) and  $0.75 \text{ kg/m}^3$  in a range of  $0.09$  to  $1.77 \text{ kg/m}^3$  (i.e.  $< + 45\%$ ), respectively. The predictions for potassium were also encouraging ( $r^2 = 0.70$ ). The standard error was  $0.62 \text{ kg/m}^3$  in a range of  $0.81$  to  $6.49 \text{ kg/m}^3$  (i.e.  $< + 12\%$ ) (Scotford et al., 1997).

### 3.3. MESPRO

MESPRO is a mathematical model for estimating the amount and composition of stored slurry produced by fattening pigs (Aarnink and van Ouwerkerk, 1990; Aarnink et al., 1992). The model was developed for the common situations on Dutch pig farms characterised by storage of slurry under slatted floors in the pig house. The aim of the work in *SWAMP* was to assess the potential use of the model for pig houses in Germany and Italy and thus to see if such an approach would be practical in other areas of Europe. In order for the approach to be successful the MESPRO model was modified. The model output is highly influenced by the input parameters feed intake, water to feed ratio, digestibility of crude protein, digestibility of N-free extract and ambient temperature. Accurate information of these parameters is essential for practical applicability of the model. In some cases it was clear that inaccuracy in the measurement of some parameters had a large effect on the calculated slurry volume and nutrient content. To increase the applicability of MESPRO in such situations it is necessary to use default values for the less essential parameters and limit the number of variables to the essential parameters.

### 3.4. Balance Approach

A nutrient input/output balance for pig and cattle farms was developed and evaluated. The approach could be used to predict slurry nutrient values in situations where all the parameters required in the complex MESPRO model were

not available. The hypothesis proposed for the balance approach to estimate the nutrient value of slurry was:

Nutrients in manure (kg) = nutrients in feed (kg) - nutrient removal in animal product (kg)

$$N_{\text{calc}} = N_{\text{input}} - N_{\text{removal}}$$

The approach was tested by correlating the calculated value ( $N_{\text{calc}}$ ) with the measured value of nutrient content by laboratory analysis.

The results achieved indicated that the balance approach had potential to provide an estimate of the nutrients contained in the manure without having to physically sample and test the material. In general, the approach tended to overestimate the nutrients in the slurry. This is not surprising as  $N_{\text{calc}}$  is by definition the upper limit for the nutrient concentration in the slurry. In the case of nitrogen there is no provision for known losses (e.g. volatilisation) that occur between excretion and measurement. Consequently,  $N_{\text{calc}}$  would be expected to be greater than  $N_{\text{measured}}$ .

#### 4. Development of a prototype application system

A prototype application system was designed and fabricated (Lenehan et al., 1997). The work involved the testing and selection of mechanical components, the fabrication and assembly of the tanker system and the development of a PC based control system. The tanker system uses a hydraulically driven positive displacement pump (Vogelsang) to allow control of application rate. Control is achieved using an electrohydraulic proportional valve (Danfoss) receiving a signal from the control system. A bandsreader is fitted to ensure even lateral application rate is achieved. A prefill mascerator (Vogelsang) is fitted on the inlet port of the tanker to reduce the risk of blockages when applying slurry with the bandspreading device. The in-line nutrient sensing system is mounted on the side of the tanker and is constructed from a 2.84 m length of 0.1 m diameter ABS pipe (Class C). The individual physical and chemical sensors are connected using suitable adapters. An in-cab PC is used as the principle hardware device with appropriate software developed to carry out required operations. A schematic diagram of the Control System Structure (CSS) is shown in Figure 2. The required CSS software is divided into four sections:

(i) CSS 1 - Control software for nutrient measurement

This software is able to accept information on nutrient content either from the in-line nutrient sensor or direct input to the in-cab PC via keyboard/floppy disk.

- (ii) CSS 2 - Calculation software to determine required volumetric application rate  
This software uses the data from CSS 1 and the ADS/ERA software operating in the farm or advisory office to calculate the required volumetric application rate.
- (iii) CSS 3 - Control software for spreading operation  
This software uses data from CSS 2, a forward speed sensor and a slurry pump speed sensor to produce a control signal for an electrohydraulic proportional valve to maintain correct slurry pump speed. In addition, CSS 3 functions in parallel with the tanker monitoring system which continuously checks tanker contents and system faults detected by tanker mounted PLC (Programmable Logic Controller). CSS 3 provides information on actual application performance for subsequent processing by the final section of CSS software.
- (iv) CSS 4 - Software for data generation for output files  
This software processes the data on actual application performance in the field and prepare files which can be transferred by floppy disc to the office PC operating the ADS/ ERA software for record updating.

The computer screen is used in the cab to present continuous information as analogue displays to the operator on slurry pump speed, application rate, forward speed, tanker contents and fault condition indication.

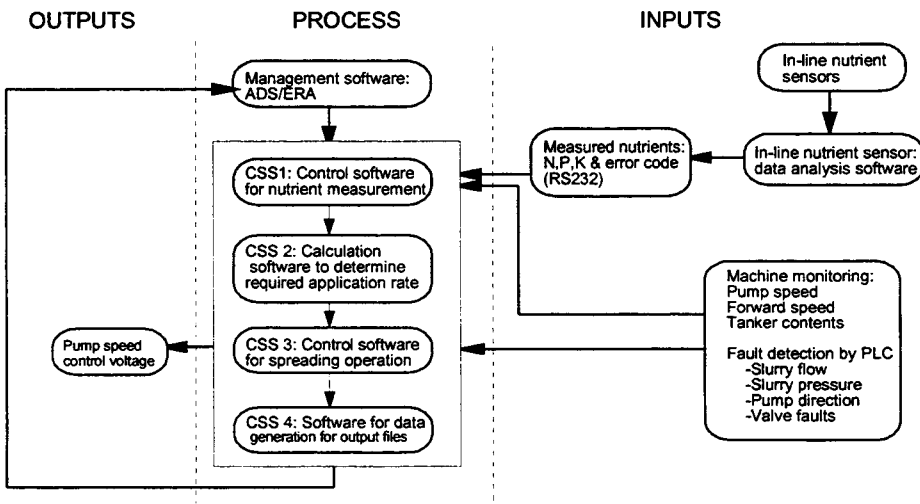

Figure 2  
Control System Structure

A field testing program was carried out in Ireland. The results of the testing program showed that with the bandspreader an even distribution could be achieved independent of slurry pump speed. The coefficient of variation (CV) on lateral achieved varied from 9 to 14%. The CV obtained for longitudinal distribution was less than 10%. The results are in good agreement with earlier research carried out by Huijsmans and Hendrikz (1992).

## 5. Conclusions

The *SWAMP* project provides the framework for an integrated slurry management system. It attempts to draw together a number of approaches. The concepts of Environmental Risk Assessment (ERA) and Application Decision Support (ADS) were introduced and developed. A number of methods for the rapid provision of information on nutrient content of slurries in a practical way which can be used by the farmer were examined and tested. A full scale prototype and associated control technologies has been designed and fabricated to achieve the goals of accurate application of precise quantities of slurry nutrients while minimising pollution risks.

## 6. References

**Aarnink, A.J.A. and van Ouwerkerk, E.N.J.** (1990). Model voor het berekenen van het volume en de samen stelling van vleezvarcansmest (MESPRO) IMAG-DLO, Wageningen, Rapport 229, 58 pp.

**Aarnink, A.J.A., van Ouwerkerk, E.N.J. and Verstegen, M.A.W.** (1992). A mathematical model for estimating the amount and composition of slurry from fattening pigs. *Livestock Production Science*, 31 (1992), 133-147.

**Burton, C.H., Beck J., Bloxham P.F., Derikx P.J.L., Martinez J., (eds)** (1997). « Manure management - treatment strategies for sustainable agriculture ». Silsoe Research Institute, Wrest Park, Silsoe Bedford, UK. 181 p.

**Carlson, G.** (1994). Nutrient utilisation of slurry by using different application strategies and techniques. *Animal Waste Management Proceedings of 7<sup>th</sup> Technical Consultation of the ESCORENA Network on Animal Waste Management*, J.E. Hall, ed.; Bad Zwischenahn, Germany, 17-20 May 1994, pp. 171-181.

**Derikx, P.J.L. and Beurskens, A.G.C.** (1997). Analysis of manure composition by means of rapid lab method, a ring test IMAG-nota, p 9718, Wageningen, 22 pp.

**Eckersten, H., Jansson, P-E and Johnsson, H. (1996).** The SOIL N model User's Manual. Department of Soil Sciences, Swedish University of Agricultural Sciences, Uppsala, Sweden.

**Fluck, R.C. and Baird, C.D. (1980).** Agricultural Energetics, AVI Publishing Company, INC, Westport, Connecticut.

**Huijsmans, and Hendriks, J.G.L. (1992).** Slurry distribution of spreader and injectors. In Proceedings of International Conference on Agricultural Engineering, Swedish Institute of Agricultural Engineering, Uppsala, Sweden, p 622-623.

**Jansson, P-E (1996).** Simulation model for soil water and heat conditions. Report 165, Department of Soil Sciences, Swedish University of Agricultural Sciences, Uppsala, Sweden, 82 pp.

**Lenehan, J.J., Keppel, D., Carton, O.T., Cumby, T., Scotford, Huijsmans, J. and Perros, J. (1997).** Development of *SWAMP* prototype slurry spreader. In Proceedings of 23<sup>rd</sup> Irish Grassland and Animal Production Association Research Meeting, University College Dublin, April 1997.

**Lewis, D.R. and McGechan, M.B. (1998).** Watercourse pollution due to surface run-off following slurry spreading PART 1, Calibration of the soil water simulation model SOIL for fields prone to surface runoff. Journal of Agricultural Engineering Research 72, (3), 275-291.

**McGechan, M.B., Graham, R., Vinten, A.J.A., Douglas, J.T., and Hooda, P.S. (1997).** Parameter selection and testing the soil water model SOIL. Journal of Hydrology, 195, 312-344.

**O'Bric, C., Carton, O.T., O'Toole, P., Cuddihy, A. and Lenehan, J.J. (1992).** Nutrient values of cattle and pig slurries on Irish farms and the implications for slurry application rates. Irish Journal of Agricultural and Food Research, Volume 31, No. 1 pp. 89-90.

**Pain, B. (1989).** Atmospheric pollution from slurry. In: Proceedings of slurry and sludge management meeting. IGAP Hurley, Chalcombe Publications UK.

**Piccinini, S. and Bortone, G. (1991).** The fertiliser value of agricultural manure: simple rapid methods of assessment. Journal of Agricultural Engineering Research, 1991, 49: 197-208.

**Scotford, I.M., Cumby, T.R., Richards, P.A., Keppel, D., Lenehan, J.J. (1998).** Development of an in-line nutrient sensing system for livestock slurries (submitted). Abstract for publication in proceedings of AgEng 98 Conference, Oslo, Norway.



**Tunney, H. and Bertrand, M. (1989).** Rapid field tests for estimating dry matter and fertiliser value of animal slurries. In: Proceedings of CIGR, 11<sup>th</sup> International Congress on Agricultural Engineering, September 1989, Dublin. Balkema, Rotterdam, ISBN 90 6191 9762.

**Tunney, H., Breeuwsma, A., Withers, P.J.A. and Ehlert, P.A.I. (1997).** Phosphorus fertiliser strategies: Present and Future. In: Proceedings of International Workshop, Teagasc, Johnstown Castle, Ireland, Phosphorus Loss from Soil to Water, CAB International, UK ISBN 085199 1564.

**Wu, L., McGechan, M.B., Lewis, D.R., Hooda, P.S. and Vinten, A.J.A. (1998).** Parameter selection and testing the soil nitrogen dynamics model SOILN. Soil Use and Management (in press).

**Wu, L. and McGechan, M.B. (1998).** Simulation of biomass, carbon and nitrogen accumulation in grass to link with a soil nitrogen dynamics model. Grass and Forage Science (in press).

# Mineral bookkeeping, new manure legislation in The Netherlands

## *Comptabilité des minéraux, nouvelle législation sur le lisier aux Pays-Bas*

**P.J.L. Derikx**

Institute of Agricultural and Environmental Engineering (IMAG-DLO),

P.O. Box 43, NL-6700 AA Wageningen, The Netherlands.

e-mail: p.j.l.derikx@IMAG.DLO.NL

### **Abstract**

*Intensive livestock production in The Netherlands gave rise to considerable surpluses of manure on individual farms, which may create an environmental risk. Attempts in the past to improve manure distribution or to change the animal feed composition to reduce mineral output of the animals were only partly successful. Therefore, additional measures are needed to avoid further environmental pollution.*

*Future measures should be optimised in terms of individual freedom for farmers, accuracy, possibilities for verification and tamperproofness. As a result the Mineral Bookkeeping System is introduced. Each farmer has to show an annual balance between minerals entering and leaving his farm. When the input exceeds the output a severe tax has to be paid. The level of this tax is so high, Dfl 10.-/kg P<sub>2</sub>O<sub>5</sub>, that unbalanced mineral bookkeeping threatens the economic feasibility of the farm.*

*To enable farmers to account accurately for all the phosphorous and nitrogen flows from and to their farms they are offered tables containing national average figures about the nutrient content of a number of agricultural products. In addition the farmer can include farm specific data. For obtaining accurate data about the quantity of animal manure minerals sampling and weighing of each load is obligatory. Recent research has made available new techniques that meet the required accuracy levels, possibilities for verification and tamperproofness. The different technical modules will be introduced into farmers practice step by step. Final goal is to obtain accurate information, with as little human effort as possible and preferably offering no options for misuse.*

*The article describes the various aspects of the mineral bookkeeping system in detail and discusses technical options and strategies to improve accuracy and practical value of the system.*

**Keywords** : balance - nutrients – sampling – environment

## Résumé

Aux Pays-Bas, l'élevage intensif a amené la constitution de considérables excédents de lisier dans les exploitations individuelles, ce qui peut présenter un risque pour l'environnement. Les efforts déployés dans le passé en vue d'améliorer la répartition ou de modifier la composition de l'alimentation du bétail pour réduire la production de minéraux des animaux n'ont réussi qu'en partie. Aussi des mesures complémentaires sont-elles nécessaires pour éviter toute pollution supplémentaire de l'environnement.

Les mesures futures devraient être optimisées sur le plan de la liberté individuelle des éleveurs, de la précision, des possibilités de vérification et de la protection contre la fraude. Le système de comptabilité des minéraux a été introduit à cette fin. Chaque agriculteur doit présenter annuellement le bilan de la quantité de minéraux entrant et quittant son exploitation. S'il en entre davantage qu'il n'en sort, une taxe substantielle doit être payée ; son niveau est si élevé, 10 florins / kg  $P_2O_5$ , (soit environ 30 FF/kg  $P_2O_5$ ) qu'une telle situation n'est pas viable économiquement.

Pour permettre aux agriculteurs d'estimer avec précision chacun des flux d'entrée et de sortie de phosphore et d'azote de leur exploitation, des tableaux contenant les moyennes nationales en matière de contenu nutritif leur ont été remis. Il leur est de plus possible d'inclure des données spécifiques à l'exploitation. Afin d'obtenir des chiffres précis sur la quantité de minéraux contenue dans le lisier, il est obligatoire de procéder à des prélèvements d'échantillons et à la pesée de chaque chargement. De nouvelles techniques permettant de répondre aux exigences quant aux niveaux de précision, aux possibilités de vérification et à la protection contre la fraude sont devenues disponibles grâce à des recherches récentes. L'introduction dans la pratique des nouveaux modules techniques concernés va se faire petit à petit. L'objectif final est d'obtenir des informations précises avec le moins possible d'effort humain, suivant un système qui, de préférence, ne soit pas susceptible d'être enfreint.

L'article décrit plus en détail les différents aspects du système de comptabilité minérale et examine des choix techniques et des stratégies visant à améliorer l'exactitude et la valeur pratique de ce système.

**Mots clés :** bilan - substances nutritives - échantillonnage - environnement

## 1. Current situation in the Netherlands

Over the last decades livestock production in the Netherlands has developed into a highly specialised branch of agricultural activity. Due to the availability of artificial fertilisers and cheap feed components on the world market the productivity per hectare increased and the production of especially pigs and chickens was no longer linked to the availability of arable land to produce animal feed. As a result the number of animals has increased in this period as shown in Table 1.

	1960	1980	1984	1988	1996
Dairy cattle	1.628	2.356	2.549	1.971	1.665
Other cattle	1.879	2.870	2.967	2.739	2.885
Pigs <sup>1</sup>	2.955	10.14	11.15	13.93	14.40
Laying hens	37.90	37.50	42.70	45.40	39.50
Broilers	45.00	38.60	34.50	40.30	44.10

*Table 1.*  
*Changes in the number of livestock in The Netherlands*  
*in the period 1960 – 1996 expressed as millions*  
*(source: Dutch Ministry of Agriculture, Nature and Fisheries, 1997).*

The increasing trend is most striking for the number of pigs and broilers. With the growing number of animals there was an increase in the amount of manure produced. Due to measures taken at farm level the annual manure production has decreased over the last decade (Table 2). As an example, the amount of slurry produced annually by one fattening pig has decreased from 1.5 m<sup>3</sup> to 1.1 m<sup>3</sup>. This was mainly achieved by a more strict water management on the farms. Spillage of water in the houses was avoided and rainwater was prevented to mix with the slurry into the storages.

	1986	1996
Cattle	72.6	59.2
Pigs	19.2	15.9
Chickens	2.5	2.4

*Table 2.*  
*Annual manure production in The Netherlands expressed in millions of tons.*  
*(source: Central Office for Statistical Data)*

Not only the amount of manure but also the composition is of importance when considering the effect on the environment. Due to the differences in water management on the farms the composition of slurry and manure in The Netherlands may differ considerably from the composition common in other countries. In Table 3 the major constituents of the manure are mentioned.

	Dry matter	Organic matter	N	P <sub>2</sub> O <sub>5</sub>	K <sub>2</sub> O	MgO	Na <sub>2</sub> O
<b>Slurries :</b>							
Cattle	90	66	4.9	1.8	6.8	1.3	0.8
Veal calves	20	15	3.0	1.5	2.4	-	-
Sows	55	34	4.2	3.0	4.2	1.1	0.6
Fattening pigs	90	60	7.2	4.2	7.2	1.8	0.9
Laying hens	145	93	10.2	7.8	6.4	2.2	0.9
<b>Solid manure :</b>							
Laying hens (belt)	515	374	24.1	18.8	12.7	4.9	1.5
Laying hens (bedding)	640	423	19.1	24.2	13.3	5.3	4.2
Broilers	605	508	30.5	17.0	22.5	6.5	3.0

*Table 3.*

*Average composition of slurry and manure in The Netherlands expressed as g/kg wet product. (source: Quantitative information Livestock production, 1997 – 1998).*

As already mentioned the production of pigs and chickens is no longer linked to the area of arable land available in the direct vicinity of the farm. As a result farms with larger numbers of animals and hardly any land for manure application were created. A surplus of manure on farm level is the logic outcome of this development. Moreover, as these types of farms are regionally concentrated in the south-east and the middle east of the country there is also a manure surplus on regional level. Measures taken in the past to improve the transport of manure surpluses to regions with more arable land and measures to decrease the mineral content of the feed were only partly effective. Therefore, Dutch authorities had to take additional measures to avoid further environmental pollution by excess use of manure in surplus areas. Measures taken so far did not distinguish between individual farms, which was felt as unfair by those who were more strict in their mineral management.

In addition, authorities occupied with the supervision of manure legislation so far were aware of the poor possibilities for verification and the extended possibilities for tamper. This gave rise to a large number of court cases, where judges often had to dismiss farmers from any prosecution due to lack of evidence.

New legislation should overcome the disadvantages mentioned above as good as possible. Summarising this implies that new measures not only should treat farmers more individually, but also create better tools for the authorities to verify the data supplied by the farmers. Techniques included in a new system should be designed in a way that tamperproofness is guaranteed.

missing he has to pay a levy of Dfl.10.- and for nitrogen the levy amounts to Dfl. 1.50 per kg.

## MINERAL BOOKKEEPING SYSTEM

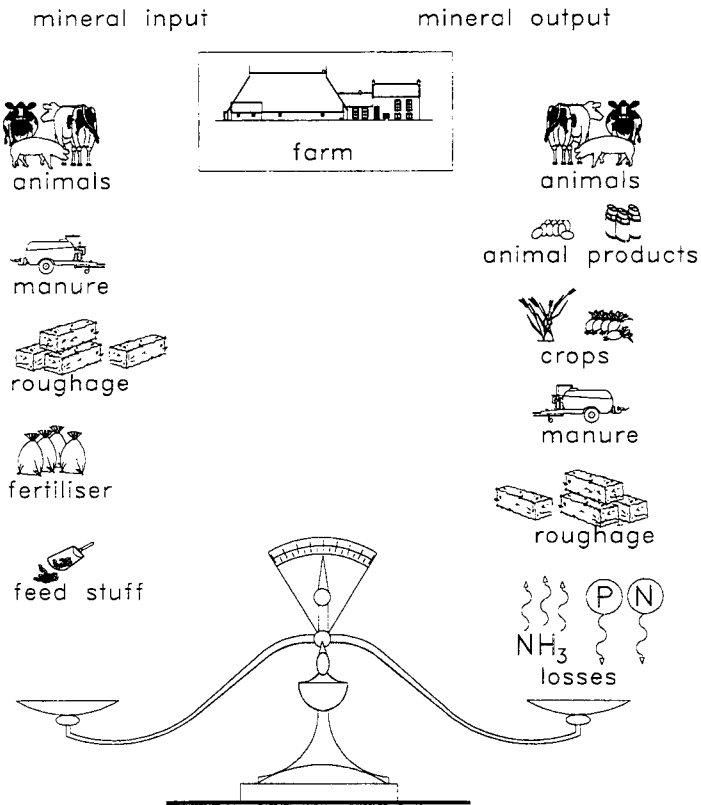

*Figure 1.  
Schematic representation of the mineral bookkeeping system*

All mass flows containing nitrogen and/or phosphorous should be included accurately in the mineral bookkeeping. Figure 1 represents the essential of the system schematically. For those flows, which mineral composition only differ slightly from farm to farm or with time, standard figures for the nitrogen and phosphorous content are provided. Animal products and crops are typical examples for this category. For flows where these criteria imply to a lesser extent farm specific data must be collected, e.g. number of hectares and animals belonging to the farm. Major mineral input flows are typically artificial fertilisers or animal feed concentrates. On request the suppliers provide the farmer with detailed information on the mineral content of their products. Animal manure forms a special flow in this

All mass flows containing nitrogen and/or phosphorous should be included accurately in the mineral bookkeeping. Figure 1 represents the essential of the system schematically. For those flows, which mineral composition only differ slightly from farm to farm or with time, standard figures for the nitrogen and phosphorous content are provided. Animal products and crops are typical examples for this category. For flows where these criteria imply to a lesser extent farm specific data must be collected, e.g. number of hectares and animals belonging to the farm. Major mineral input flows are typically artificial fertilisers or animal feed concentrates. On request the suppliers provide the farmer with detailed information on the mineral content of their products. Animal manure forms a special flow in this respect. In particular on the most intensive farms it is the most important mineral output flow. Its composition differs both from farm to farm and with time. Therefore, standard figures, based on averages from a large number of farms, are inaccurate for most individual farms. Within the new legislation the standard figures for the mineral content of manure are included in the law by the Ministry of Agriculture, Nature management and Fisheries. It is a demonstration of the political value of these figures. The values are chosen at such a level that they are unfavourable for most farmers. As an alternative they are allowed under conditions to use farm specific figures for the manure composition. The conditions mainly deal with the procedures and techniques involved in estimating the manure composition. More details will be given in the section about technical aspects.

### **3. Introduction of the mineral bookkeeping system**

From the description above it may be clear that the introduction of the new system means a large step for farmers, authorities and people involved in agricultural business. As the mineral bookkeeping system is meant as protection of the environment the most intensive farms are first included. As a result about 50,000 Dutch farms with a livestock density larger than 2.5 livestock units per hectare are fully involved in the system from the start at January 1<sup>st</sup> 1998. Other farms will follow suit step by step. In 2000 all farms with livestock and from 2002 also the farms with only arable land will have to present a total mineral account to the Dutch authorities. The last two categories now only have to prove that the amount of minerals used on their farm, originating from animal manure and calculated on base of standard figures, does not exceed a given limit.

### **4. Technical aspects of the determination of the minerals present in manure**

In order to determine accurately the quantity of minerals leaving or entering the farm with a load of manure not only the mineral content but also the size of the load is of interest. As levies are based on these figures, Dutch legislation states that estimation of the size of the load can only be done by calibrated weighing techniques. Currently on board weighing systems are adapted to fit on slurry tankers.

and therefore the operator cannot influence either the moment of sampling nor the sample composition. The high degree of automatization increases the tamperproofness of the technique and enables the automatic recording of relevant data which relieves the operator of the transport of a large part of his administrative job.

The box shown below the sampling device in Figure 2 contains the sample bottle and is meant to handle the sample bottle fully automatic. Prior to the sampling process the bottle and the lid are introduced in the box separately. An in built camera system checks the cleanness and records the numbers present on both. Only then the bottle is available for the sample and the sampling process can be started. After completion of this process the lid is placed on the bottle automatically and the closed bottle is available for further transport to the laboratory. The sample bottle and lid are special designed for this sampling system. After closing the lid can only be removed by breaking a security strip. Laboratories only accept samples with intact security strips. At the moment the technical development of the sample bottle handling box and the techniques included is still running. Compulsory application of this part of the system is foreseen for 1<sup>st</sup> of January 2000.

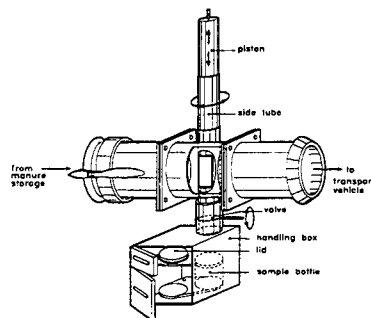

*Figure 2.*  
*Schematic representation of the side tube slurry sampling technique.*

The samples obtained have to be sent to a laboratory for the determination of the total content of nitrogen and phosphorous. The Netherlands is the first country with established standard methods for the analysis of slurry and manure. Moreover, the laboratories involved in these analysis have to meet special criteria in addition to Good Laboratory Practice. Regularly held ring tests and audits by the certifying organisation guarantee the quality of the participating laboratories. Data recorded for each load of slurry or manure are not only reported to the farmers involved but also to a registration office, ran by the Dutch authorities.

## 5. Costs

The levy involved in the mineral bookkeeping system amount to Dfl. 10.- per kg P<sub>2</sub>O<sub>5</sub> and Dfl. 1.50 per kg N exceeding the limits of the accepted losses. Related to the Dutch slurry composition this implies about Dfl. 60.- per ton of slurry originating



The samples obtained have to be sent to a laboratory for the determination of the total content of nitrogen and phosphorous. The Netherlands is the first country with established standard methods for the analysis of slurry and manure. Moreover, the laboratories involved in these analysis have to meet special criteria in addition to Good Laboratory Practice. Regularly held ring tests and audits by the certifying organisation guarantee the quality of the participating laboratories. Data recorded for each load of slurry or manure are not only reported to the farmers involved but also to a registration office, ran by the Dutch authorities.

## 5. Costs

The levy involved in the mineral bookkeeping system amount to Dfl. 10.- per kg  $P_2O_5$  and Dfl. 1.50 per kg N exceeding the limits of the accepted losses. Related to the Dutch slurry composition this implies about Dfl. 60.- per ton of slurry originating from fattening pigs. From these figures it can be derived that it is economically unfeasible for a farmer to produce pigs without a proven discharge of their slurry. Moreover, the levy for phosphorous will be increased to Dfl. 20.- per kg  $P_2O_5$  from 2000 on.

The mineral bookkeeping system increases the need for an accurate financial administration at each farm. Most figures needed for the mineral bookkeeping system are linked with the financial bookkeeping. When farm specific data are needed for the amount of minerals in the manure or slurry additional costs have to be made for weighing, sampling and analysing the individual truck loads. Depending on the situation these costs range from Dfl. 50.- to Dfl. 100.- per load.

Not only farmers are confronted with additional legislation and costs. Transport companies as well get their part. They pay either for weighing at a public weighing facility and lose some time by visiting such a place or they have to invest in on board weighing equipment. The preference for either of the possibilities is linked to particular circumstances such as the distance to a public weighing facility and the number of transports served by a particular transporting vehicle. The price of on board weighing systems amount from Dfl. 30,000.- to Dfl. 75,000.-, depending on the configuration of the weighing system and the vehicle.

A fully automatic sampling device will cost about Dfl. 25,000.-, and with the introduction of a fully automatic sample bottle handling it will be doubled. The price of an analysis in one of the certified laboratories will amount from Dfl. 30.- to Dfl. 50.-.

## 6. Future developments

Introduction of such a complex system is hardly ever done at once. Furthermore, the interest of different parties involved are so much apart that it is nearly impossible to serve them all at the desired level at the start. The Dutch government has chosen for a start at 1<sup>st</sup> January 1998 with a system which already contains the headlines of the approach and then extend both the number of farms and the level of verification and tamperproofness. Especially for these last two aspects additional technical solutions are desirable. Tamper with the sample composition and the sample bottle will be more difficult when both the automatic sampling and the automatic sample bottle handling will be compulsory.

To improve possibilities of verification additional data from every transport are needed. By the introduction of the mineral bookkeeping system a new transport form is introduced, with a first step towards this extended data recording. With the availability of highly automatic sampling equipment on the transporting vehicle a further extension of the data recording comes into sight without increasing the effort required from the operator. At the moment studies are carried out to investigate possibilities of application of modern data transfer together with automatic data recording on the transporting vehicle. The intention of these studies is to make the paper version of the transport form superfluous and make the data related to a given transport available for parties involved as soon as possible, preferable before the transport is completed.

Introduction of such sophisticated technical solutions can only be successful when all parties involved underline the benefits. Automatic sampling and sample bottle handling reduce not only the possibilities for tamper but also free the transporting companies from discussion with farmers about the correctness of the sample. Automatic data registration and transfer not only enable an extension of the parameters but also increase the efficiency for all parties involved. At the moment the information collected on a paper version of the transport form has to be copied at the administration of the transporting company, the laboratory and the registration office of the authorities. As it is hand written information the chances for intended or unintended errors or difficulties with the readability are not imaginary.

Another aspect of future development is the level of accepted losses related to ground linked activities. At the start the accepted losses are at a level that rather limited actions of farmers are needed to meet these standards. With time these levels will decrease (Table 4) and more effort from farmers is needed not to exceed these levels.

	1998	2000	2002	2005	2008 e.v.
<b>Phosphorous (P<sub>2</sub>O<sub>5</sub>) :</b>					
Natural environment	10	10	10	10	10
Agricultural land	40	35	30	25	20
<b>Nitrogen :</b>					
Natural environment	50	50	50	50	50
Grassland	300	275	250	200	180
Other agricultural land	175	150	125	110	100

*Table 4.*

*Accepted losses for phosphorous and nitrogen in The Netherlands related to the mineral bookkeeping system, values expressed as kg per hectare per year.*

Figures shown in Table 4 beyond the year 2000 serve as an indication as for that year a political evaluation of the mineral bookkeeping system is announced and the level of accepted losses will be subject of further discussion.

## 7. Conclusions

The mineral bookkeeping system, as introduced at the beginning of this year in The Netherlands, creates optimal freedom to take individual differences between farms into account without losing the desirable accuracy. Within the agricultural business environmental unsound use of minerals in general and animal manure in particular will become economically unattractive.

The inclusion of highly automatic techniques improve possibilities for verification and tamperproofness without converting farmers or truck drivers into administrators. Modern data communication techniques may improve the efficiency of the administration process.

## 8. Further reading

**Derikx, P.J.L., J.G.L. Hendriks and P.J.W. ten Have, 1996.** Management of livestock manures in The Netherlands – the current situation. *Ingénieries, Special issue 1996, 56-64*

**Derikx, P.J.L., N.W.M. Ogink and P. Hoeksma, 1997.** Comparison of sampling methods for animal manure. *Neth. J. Agric. Sci., 45, 65-79.* Minas, the minerals accounting system, Ministry of Agriculture, Nature management and Fisheries, <http://www.minlnv.nl/minas/bib/misamen.htm>

**Burton, C.H., J. Beck, P.F. Bloxham, P.J.L. Derikx and J. Martinez, 1997.** Manure management, treatment strategies for sustainable agriculture. ISBN 0953128202, Silsoe Research Institute, UK. 181 pp.

# **The implications of Irish legislation and regulations for the land spreading of manures from intensive agricultural enterprises**

*Implications de la législation Irlandaise et des réglementations pour l'épandage  
des déjections en exploitation d'élevage intensif.*

**Owen T. Carton,**  
Teagasc, Johnstown Castle,  
Wexford, Ireland  
E-mail :  
ocarton@johnstown.teagasc.ie

**William L. Magette,**  
Dept. of Agricultural and Food Engineering,  
University College Dublin, Earlsfort Terrace,  
Dublin 2, Ireland.  
E-mail : bmagette@iveagh.vcd.ie

## **Abstract**

*Improving manure management on farms is essential to sustainability. In Ireland, considerable progress in this context has been made in the last decade. However, newly introduced legislative requirements are now demanding even greater change for larger pig, poultry and mushroom enterprises. Achieving both a better balance between the applied manure nutrient loads, particularly nitrogen and phosphorus and the crop requirements are now a requirement. The implications are that larger land spreading areas are required than have been traditionally used by these enterprises. However, compliance with the Environmental Protection Agency's Batneec regulations; the national Code of Good Agricultural Practice to Protect Groundwater from Pollution by Nitrates; the general exclusion of land associated with the national Rural Environment Protection Scheme; the localised concentration of the enterprises in parts of the country and their general separation from tillage areas all impact seriously on the availability of suitable spread lands for the manure. In the absence of improvements in the national water quality it is inevitable that other agricultural enterprises will be regulated. Therefore, current legislative controls must be carefully monitored and any future control considered in context so that the viability of the manure land spreading option remains, particularly for the intensive agricultural enterprises. Sustainable alternatives do not currently exist.*

## **Résumé**

L'amélioration de la gestion des déjections à la ferme est indispensable au maintien de leur durabilité. En Irlande, des progrès considérables ont été réalisés au cours des dix dernières années. Cependant les nouvelles réglementations en vigueur exigent de plus grandes modifications des pratiques notamment pour les exploitations porcines, avicoles et champignonnières de taille importante. Il est en

effet exigé un équilibre entre la charge en éléments minéraux épandus particulièrement N et P et les besoins des cultures. Cela implique que davantage de surfaces d'épandage sont à présent nécessaires. Cependant, le respect des différents codes et réglementations en vigueur (Réglementations Batneec de l'Agence pour la protection de l'Environnement ; Le code national de bonnes pratiques agricoles pour la protection de la pollution de l'eau par les nitrates...) affecte considérablement la disponibilité des surfaces aptes à l'épandage.

En l'absence d'amélioration au niveau national de la qualité de l'eau, il est inévitable que d'autres activités agricoles seront également soumises à ces nouvelles réglementations. Il est toutefois important de conserver l'option épandage, notamment pour les exploitations intensives. Les alternatives pour une gestion durable ne sont pas encore disponibles.

## 1. Introduction

It has been estimated that 153 m t of manure are produced annually in Ireland by farmed livestock (Carton and Magette, 1996). Cattle and sheep manure account for almost 43 m t which require management annually. Pig and poultry enterprises produce an estimated 2.8 and 0.6 m t of manure, respectively, every year. There is in excess of 0.25 m t of spent mushroom compost (SMC) to be managed each year. Land spreading is the preferred management option for all manures.

Public attention has focused on intensive agricultural enterprises (IAE), *i.e.* pig, poultry or mushroom farms, in terms of their impact on water quality in spite of the fact they account for less than 10% of total quantity of manure requiring management. A factor in this is that their development has largely been confined to a limited areas of the country. For example, about 40% of the national sow herd is located in two of the 26 counties. In one county, poultry and mushroom production account for 47% and 12%, respectively, of the gross agricultural output (GOA) compared with the national figures of 4% and 2%, respectively (Teagasc, 1994). There is further concentration of IAE within counties. Poultry and mushroom enterprises account for over 60% of the GAO in one of seven river catchments within one county (MAWMS, 1994).

In some of these areas with IAEs, particularly, the North West of the country, water quality is inferior compared with other regions (MAWMS, 1994). The first major Irish case of eutrophication in an Irish lake was in this region, Lough Sheelin, and was linked to the expansion of agriculture, including pig enterprises, in the catchment. It has left a lasting legacy in the public perception about the impact of IAE on water quality. This is reflected in legislation through the Environmental Protection Agency's (EPA) Integrated Pollution Control (IPC) licensing requirements for pig and poultry enterprises above a specified size (EPA, 1997).

## 2. IAE nutrient balances

Generally, there is no link between crop and animal production on IAE. Most nutrients are imported in the form of cereal based animal feeds or composts on mushroom farms. The sale of meat, eggs or mushrooms results in the export of a fraction of the imported nutrients. Therefore, an annual farm nutrient surplus is generated in the manure or SMC. Logically, the nutrients in the manure should be recycled to the land that provided the inputs.

However, the spatial separation of the two enterprises militates against the practice. Crop production is primarily confined to the southern and eastern regions while IAE's are somewhat concentrated in the north east and a number of other smaller areas within the country thus giving rise to high manure transport costs. Consequently, the traditional approach has been for IAE manure to be applied to limited areas of grassland in the vicinity of the enterprise. The nutrient supply in the applied IAE manure generally exceeded the crop requirements as the nutrient deficit on grassland farms is relatively small (Tunney *et al* 1996 and Culleton *et al* 1996). In some cases the situation was exacerbated by making no adjustment, on the recipient land, in the inorganic fertiliser applications to take account of the nutrients already supplied by the IAE manure. The result has been soil test phosphorus (STP) levels of the IAE manure spread lands that are in excess of those required for crop production (e.g. Figure 1).

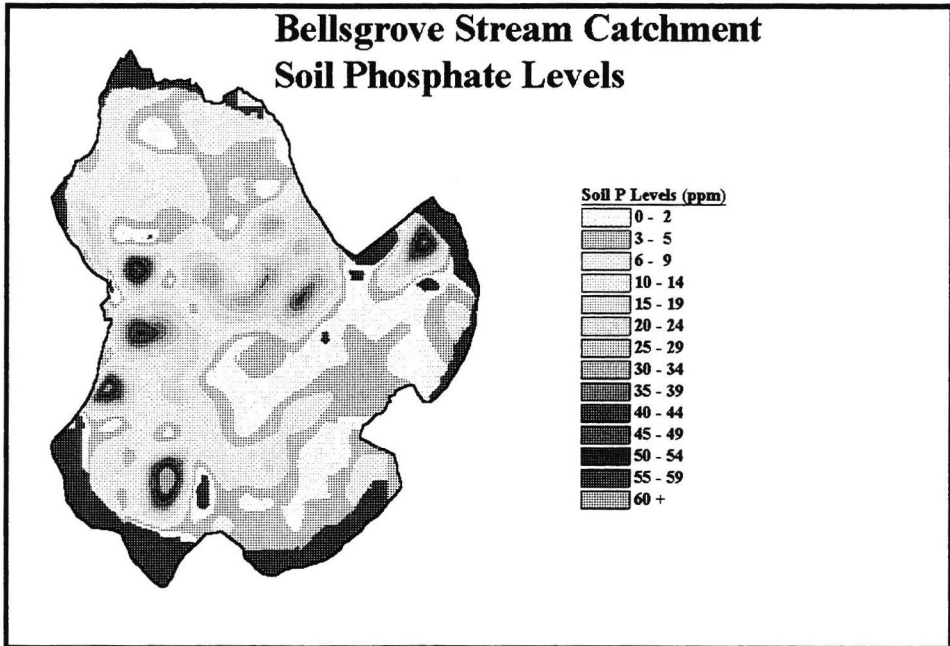

*Figure 1*

*The distribution of STP within the Bellsgrove catchment Co. Cavan. Areas with elevated STP are generally associated with IAE (Humphries et al, 1996).*

More than 30% of mushroom farms, 50% of poultry farms and 60% of pig farms had spread land soils with P levels greater than 15 mg/l (MAWMS, 1994). This compared with less than 10% on farms with grass based enterprises only.

The potential for phosphorus (P) loss to water is positively correlated with STP. Therefore, improved nutrient management strategies to achieve better balances between the nutrient load in the IAE manure and the needs of crop production are being introduced in legislation and regulations. The objective is to minimise the impact of land spreading on the environmental media, particularly surface and ground water.

### **3. Legislative controls and restraints on the land spreading of manures**

The primary legislative control on land spreading of IAE manures is the IPC licensing requirement. IAE applicants for an IPC license must comply with the EPA BATNEEC (Best Available Technology Not Entailing Excessive Costs) STP requirement, which prohibits - IAE manure from being applied to land where the existing STP exceeds 15 mg/l (Morgan's Test). Other licensing controls include requirements to implement a nutrient management plan, and assessing spread lands in terms of their vulnerability to nutrient loss. Spread lands with high risk are not acceptable. Defined buffer zones between waterways, wells and buildings also are required. There has been considerable criticism of aspects of the IPC licensing requirements by the industry (Tuite, 1996 and Reilly, 1996). However, the process is in place and to date a number of licences have been issued to operators by the EPA.

The national voluntary Code of Good Agricultural Practice to Protect Groundwater from Pollution by Nitrates (COP) (DOE/DAFF, 1996) recommends an upper organic nitrogen (N) load for agricultural land - "In areas supporting high stocking rates, and provided surface and groundwater are in good condition, *i.e.* nitrate concentrations do not exceed 20 mg/l and there is no evidence of eutrophication caused by nitrates, the maximum quantity of manure and other organic materials applied to land, including that deposited by grazing animals, should be such as to ensure that the N contained therein does not exceed 250 kg/ha/annum. In all other areas, the N applied from these organic fertilisers should not exceed 210 kg/ha/annum. Lower application rates than those indicated should be observed in areas where the County Council indicates that this is necessary because nitrate level in ground waters, or because the P content of the slurry or other organic manure is causing or is likely to cause water pollution". To date the impact of this Code on manure management practices has been minimal. However, one Local Authority with polluted ground water supplies is now actively pursuing the statutory implementation of the COP in water quality black spots under its jurisdiction. It is anticipated that there will be considerable problems for some of the more intensive farmers, including grassland farmers, in these areas. It is very possible that some producers will be required with the possibility of the requirement to reduce stocking rates and remove IAE manure to suitable areas outside the affected catchment. The recently introduced Rural Environment Protection Scheme (REPS) (DAFF, 1996), which implements Council Regulation (EEC) No. 2078/92, practically eliminates the potential of participating farmers to receive IAE manure. REPS farmers cannot exceed an organic N load of 170 kg/ha/yr.

Good nutrient management involves matching nutrient inputs with offtakes. The revised Teagasc P recommendations for grassland (Carton, Ryan and Magette, 1996) challenge the concept of achieving a balance between P inputs in IAE manure and removals by the crop - particularly grass.



## **4. Implications of legislative controls and restraints on spread land availability for IAE manure**

Achieving compliance with the EPA regulations, COP and REPS create a significant challenge to the IAE operator in securing acceptable spread lands.

### **4.1. Soil test P limits**

Soils with P levels greater than EPA's STP limit of 15 mg/l are not acceptable for the application of IAE manure. The limit is based on the previous Teagasc agronomic STP level for silage production above which no P was recommended (Gately, 1994). Discounting the exemption that allowed 30 mg P /l on spread lands with low vulnerability for nutrient losses, the 15 mg/l restriction is similar to the STP limit previously proposed by Teagasc (Teagasc, 1994). The exemption was originally included to accommodate the special circumstances of IAE nutrient surpluses and their concentration in specific areas within the country. The more recent links established between STP and P loss to water and the demands for more sustainable nutrient management resulted in the establishment of the 15 mg/l EPA BATNEEC STP limit. To date, the EPA has acknowledged the special problems of IAE by **not** reducing the BATNEECSTP level to the revised Teagasc agronomic level of 10 mg/l for grassland (Teagasc, 1996). However, it has the powers to do if deemed necessary.

As already noted above traditional IAE spread lands tend to have STP levels in excess of the BATNEEC limit. Over 20% of all grassland and 27% of tillage land soil samples received at the National Soil Testing Laboratories at Johnstown Castle had STP levels above the BATNEEC limit (Coulter and Tunney, 1996). Assuming that these soil samples are an unbiased representation of Ireland's agricultural soil resource, at least one fifth of the country's agricultural land is excluded from receiving IAE manure. Intensive compared with extensive grass land will tend to have higher STP levels. This is confirmed by results from a recent Teagasc pilot nutrient management planning scheme, supported by the EU LIFE programme, to promote uptake of nutrient management planning on farms (Carton 1996). The average stocking rate and STP in two of the catchments with predominately dairy farms participating was 2.2 LU/ha and 10mg/l, respectively. However, the mean STP was 6 mg/l in a third catchment with a lower average stocking rate of 1.6 LU/ha and a greater mix of dairy and dry stock farms. It is inevitable, therefore, that compliance with the BATNEEC STP limit will require the transport manure to areas outside those normally used. It will also force IAE operators to seek spreading agreements with more extensive farms, which have lower nutrient requirements. Greater public environmental awareness and the odour associated with the land spreading of IAE manures may create further difficulties when attempting to secure new spread lands in areas with no previous history of the practice.

## 4.2. Code of Good Agricultural Practice

As noted above the COP sets a voluntary organic N load limit of 250 kg/ha in areas with no water quality problems. The limit can be reduced to 210 or 170 kg/ha in areas with known water quality problems. These N restrictions will limit the stocking rates that can be accommodated on grassland used for IAE manure applications. The maximum allowable stocking rate will depend on the organic N load applied in the manure and the COP limit (Table 1).

Applica- tion rate (t/ha)	Code of Good Agricultural Practice Organic N limit (kg/ha)											
	250				210				170			
	Pig	Poultry		SMC	Pig	Poultry		SMC	Pig	Poultry		SMC
		Slurry	Litter			Slurry	Litter			Slurry	Litter	
0	2.9	2.9	2.9	2.9	2.5	2.5	2.5	2.5	2.0	2.0	2.0	2.0
5	2.7	2.1	1.4	2.4	2.2	1.6	0.9	2.0	1.7	1.2	0.5	1.5
10	2.4	1.3	-	1.9	2.0	0.8	-	1.4	1.5	0.4	-	1.0
15	2.2	0.5	-	1.4	1.7	-	-	0.9	1.2	-	-	0.4
20	1.9	-	-	0.9	1.5	-	-	0.4	1.0	-	-	-
25	1.7	-	-	0.4	1.2	-	-	-	0.7	-	-	-
30	1.4	-	-	-	1.0	-	-	-	0.5	-	-	-
35	1.2	-	-	-	0.7	-	-	-	0.2	-	-	-
40	0.9	-	-	-	0.4	-	-	-	-	-	-	-
45	0.7	-	-	-	0.2	-	-	-	-	-	-	-
50	0.4	-	-	-	-	-	-	-	-	-	-	-
55	0.2	-	-	-	-	-	-	-	-	-	-	-

- Organic N load in IAE manure exceeds COP limit.
- The organic N content of manures used in the calculations were 4.3, 14, 26 and 8.8 kg/t for pig slurry, poultry slurry, poultry litter and SMC, respectively (DOE/DAFF, 1996). An annual organic N output of 85 kg for a livestock unit (LU) (equivalent to 1 dairy cow) was also used (DOE/DAFF, 1996).

*Table 1.*

*The stocking rate limits on grassland receiving IAE manure at a range of application rates in order to remain in compliance with COP organic N limits.*

Grassland farmers are practically excluded from receiving poultry litter or slurry if they are to remain in compliance with even the highest COP organic N limit of 250 kg/ha (Table 1). At this limit, stocking rates of 0.9 LU/ha or less are necessary where poultry litter is applied at 5 t/ha. Therefore, it is probable that poultry litter will be directed towards the most extensive farms considering that the national average stocking rate is 1.47 LU/ha. A similar, though not as severe scenario, applies to poultry slurry. Generally, only tillage farms will be in a position to receive poultry manure without exceeding the COP limit. This is a limited option as tillage crops account for 8% of agricultural land use in Ireland and there is little history of poultry manure use in these production systems. The use of improved slurry/manure spreading systems which can reliably achieve lower spreading rates and a greater integration of the poultry and tillage enterprises are required to ensure the viability of the land spreading option for poultry manure.

The lower organic N content of pig slurry and SMC eases the impact of COP on spread land availability for these manures (Table 1). In general, grassland with stocking rates in excess of 1.9 LU/ha will not be available to receive these manures under a COP restriction of 250 kg N/ha/yr. Where the lower COP limits are applied the availability of spread lands will be even more curtailed and could disappear altogether.

The introduction of REPS will exclude significant areas of the national land bank for use as a receiver for IAE manure. As presently specified there is a 170 kg organic N limit for participating farmers. Therefore, only the more extensive REPS farmers with organic N loads of less than 110 kg/ha, equivalent to a stocking rate of 1.3 LU/ha, can accept pig manure at the lower end of the application rate achievable (15 t/ha) with the commonly used vacuum tanker. SMC applied at the 10 t/ha using a rear discharge spreader will supply almost 80 kg organic N/ha. Consequently, only REPS farmers with organic N loads of less than 90 kg/ha, equivalent to a stocking rate of less than 1 LU/ha, can accept SMC and remain in compliance with the REPS limit. Generally, the use of poultry litter or slurry on REPS farms is practically excluded because of its high N content.

REPS is a financially attractive scheme for many farmers as it provides annual payments of up to £5000. The COP limit on organic N will push IAE manure towards land farmed at intensities permissible in REPS. The Government have set a national target for a 30% uptake of REPS by farmers by the end of 1999 in its recently published Sustainable Development Strategy. Failure of farmers participating in REPS to comply with the organic N limit specified will jeopardize annual payments as well as other government financial supports. There is an understandable unwillingness for them to accept IAE manure. Therefore, the combined effect of REPS and COP will move the manure towards the most extensive grassland farmers *i.e.* with stocking rates < 1.3 LU/ha. It is interesting to note only one third of farmers with stocking rates less than 1.25 LU/ha indicated that they were willing to accept IAE manure for application to their land even if it was free (Teagasc, 1994).

Nutrient requirements on the more intensive farms are being met with inorganic fertilisers even though the potential exists to utilise the nutrients in IAE manure. Instead these manures are being diverted to farms with minimal nutrient demands. The impact of COP and REPS on land spreading of IAE manure deserves further consideration in the context of achieving improvements in water quality and an integrated and diversified agriculture. However, IAE operators must adopt and implement manure management practices such as those outlined by Carton and Magette, (1998) to provide the public assurance that the option will not impact negatively on the environment.

It is unlikely that the combined impact of REPS and COP on IAE manure management options was planned national policy considering that the continued expansion of the pig industry remains Government policy.

### 4.3. Revised P recommendations for grassland.

Teagasc have recently revised their P recommendations for grassland (Teagasc, 1996). These set lower agronomic STP levels for grazing and silage ground above which no P is recommended for full crop yields. The quantities of P recommended, were also lowered. The revised recommendations have reduced the P requirements for silage and grazing by approximately 50 and 40%, respectively.

Applying nutrients at rates which meet crop requirements, including in some cases building up soil fertility, is the basis of Teagasc's nutrient management strategy. The reduced P recommendations for grassland make achieving this balance when IAE manures are applied very difficult to achieve in practice. The quantity of P applied with IAE manure at the lowest practical application rates is summarized in Table 2.

Pig slurry (15 t/ha)	Poultry Slurry (15 t/ha)	Poultry litter (10t/ha)	Spent Mushroom Compost (10t/ha)
21	75	90	42

Table 2.

*The average P (kg/ha) supplied by pig and poultry slurry, poultry litter and spent mushroom compost applied at the lowest practically achievable spreading rates.*

Note: Nutrient values for slurries, litter and spent mushroom compost from COP. These are guide values only and will vary from IAE to IAE. Application of 10 t/ha of poultry litter just exceeds the COP limit of 250 kg organic N/ha.

The P recommendations for a range of crops at soil index 3 (6.1 to 10.0 mg P/l) are given in Table 3.

Grazing (2 to 2.5 LU/ha)	Silage (2 cuts)	Cereals	Potatoes	Sugar beet
12	0	20	60	30

Table 3.

*The phosphorous recommendations (kg/ha) for a range of crops at soil Index 3*

It nearly all cases the annual application of the manure, at the rates indicated in Table 2, will result in an over supply of P compared with crop requirements. The extent of the surplus is greatest for poultry slurry and litter (Figure 2). The P recommendations are greater at the lower soil P indices therefore the surplus P applied in the IAE manure will be proportionately smaller at these lower indices. Annual balancing of nutrient inputs with outputs is difficult to achieve in practice when IAE manure is land spread, particularly to grassland.

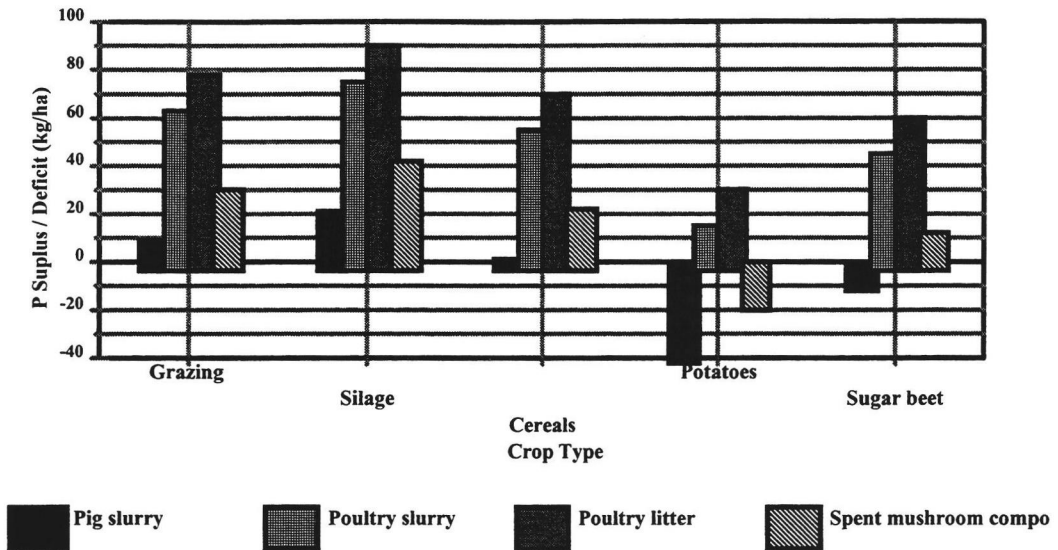

Figure 2.  
*The P surplus/deficit (kg/ha) following manure applications at lowest practical achievable spreading rates to a range of crops on soils with STP levels between 6.1 and 10 mg/l.*

Phosphorus applied in excess of crop requirements will result in a build up in STP. In effect the soil “stores” the surplus P, and while the capacity to do so is not unlimited, it is significant for many soils. Recognition that soils do have a measurable capacity to store P is essential for the viability of the land spreading option for IAE manure. Nevertheless, a sustainable balance must be achieved between the extent of soil P storage and the resulting increase in environmental risk. By regulation (*i.e.*, BATNEEC) the soil P “storage” capacity is fixed at a maximum STP of 15 mg P/l. In other words, P applications above levels required for agronomic requirements are allowed for IAEs until STP reaches 15 mg P/l. Once the STP reaches this limit new spread lands with lower STP must be located. A reduction in this limit could have serious consequences for the IAE manure land spreading option.

It must be emphasised that acquisition of spread lands cannot be accomplished capriciously. Assessment of spread land suitability for IAE manure, particularly where soil P storage is required, is essential because of the accepted potential of elevated STP as a contributory factor for increased P loss and transport to water.

#### **4.4. Site assessment for land spreading**

There is evidence that there are differences between areas within catchments in the extent to which they contribute to nutrient loss to water (Magette, 1998). Consequently, areas within catchments can be classified in terms of the risk that nutrients used there will be lost and transported to receiving waters.. While the process of ranking fields or catchments in Ireland is at early stage of development it does provide a mechanism to assist in assessing the suitability of spread lands for IAE manure applications. Only sites ranked as low risk (for their potential to lose P and for it to be transported to receiving waters) should be used to "store" the surplus P from applied IAE manure. High risk sites should not be used for IAE manure applications.

National acceptance of the combination of site assessment and the use of soil P "storage" is critical for the viability of land spreading of IAE manure. Without this, the practicality and economics of the land spreading option for IAE manure is questionable. As already noted, the COP and REPS constraints on organic N loads and the BATNEEC STP limit of 15 mg/l are creating significant difficulties in terms of available land base. Even as they are currently structured, achieving compliance for some poultry enterprises is almost impossible. Therefore, any downward revision of the current BATNEEC STP limit will require careful consideration.

#### **4.5. Buffer zones**

The inclusion of buffer zones, prescribed in the COP around water sources and houses will further diminish the quantity of available land for manure application. For example, 12 to 15% of land will be excluded in areas with a high land to water ratio while in areas with low land to water ratios this may be up to 35%.

#### **4.6. Other factors influencing their availability to receive IAE manure**

The EPA IPC license has a requirement for supplementary spread lands over and above those required to assimilate the nutrient load in the manure. This is set at 50% of the area acquired by agreement (*i.e.*, not under the ownership of the IAE operator) for new enterprises.

### **5. Costs**

There are costs associated with securing and maintaining an Integrated Pollution Control license for pig enterprises from the EPA. The costs (excluding those necessitating by structural changes at units to comply with licensing) are of three main types : application preparation, annual administrative cost, and annual

monitoring fee. For intensive pig producers, these costs are estimated to be as follows:

1. Preparation of an IPC licence or planning application, including preparation of an Environmental Impact Statement ~ £25-£40 per sow
2. Annual EPA charge (based on a 1000 sow unit) ~ £1,800
3. Annual monitoring charged incurred as a result of licensing (based on a 1000 sow unit) ~ £ 1,600 including soil and water analysis but excluding any consultancy or sampling charges.

## **6. Conclusions**

The requirements for improved manure management on farms to reduce environmental impact are nationally accepted. The growing national concern to maintain the high quality of the nation's water resources has resulted in the introduction of legislative controls on IAE manure management practices. The restrictions, noted above, on spread land availability have significant implications for the land spreading of IAE manure for both new and existing units. Newer IAE have the option to locate in areas of the Country where the implications of the constraints on spread land availability are not as great. Ideally, these should be in the tillage areas where the crops are produced that are used to feed the pigs and poultry. Such a strategy facilitates the recycling of the manure nutrients back to the areas from which the nutrients originated. However, achieving this will require clear national policy about the future development of IAE so that the local fears of their impact, particularly as many of these areas have no history of IAE, will not result in unnecessary and costly delays in the planning/licensing process.

There is a more difficult problem for existing enterprises. Locating new spread lands, in areas with already high IAE concentrations, will require greater travel distances as STP levels in the immediate vicinity of the operations exceed the BATNEEC STP limit. An adequate time scale for the full implementation of the manure management plan will therefore be necessary from the Licensing Authorities for existing enterprises.

Caution is required with the introduction of any further legislation to ensure that any new restrictions proposed combined with those already in existence do not preclude the land spreading option for IAE manure. Alternative management options for IAE manure are scarce.

## 7. References

**Carton, O.T.** (1996). Project Report, August 1, 1994 to January 22, 1996. LIFE93/IRL/A15/3116 - Farm nutrient Management. Teagasc, Johnstown Castle, Wexford. 78 pp.

**Carton O.T. and Magette, W.L.** (1996). Manures - waste or resource. IN: Proceedings of 1996 Annual Conference, Athlone. The Institution of Engineers of Ireland, 22 Clyde Road, Dublin 4, Ireland.

**Carton, O.T. and Magette, W.L.** (1998). Teagasc manure management guidelines with special reference to intensive agricultural enterprises. Draft guidelines for nutrient use in intensive agricultural enterprises (Ed. O.T. Carton). Teagasc, Johnstown Castle, Wexford. 32 - 56.

**Carton, O. T., M. Ryan and W.L. Magette (eds.)**. (1996). Phosphorus recommendations for grassland - good agronomic practice. Teagasc, 19 Sandymount Ave., Dublin 4. 99 pp.

**Culleton, N., Murphy, W.E., Murphy, J., Humphreys, J. and Jensen, J.** (1996). Phosphorus requirements for grazing. In Phosphorus recommendations for grassland - good agronomic practice. Eds O.T. Carton, M. Ryan and W.L. Magette. Teagasc, 19 Sandymount Ave., Dublin 4.

**DAFF**, (1996). Rural Environment Protection Scheme. Farm Development Service, Agri-Environmental Specifications. Revised May 15, 1996 Pp 74

**DOE/DAFF**, (1996) Department of the Environment & Department of Agriculture, Food and Forestry (1996). Code of Good Agricultural Practice to Protect Waters from Pollution by Nitrates. 57 pp

**EPA** (1997). Integrated Pollution Control Licensing. Batneec Guidance note for the pig production sector. EPA, Ardcavan, Wexford.

**Gately, T.** (1994). Soil analysis & fertiliser. Lime, animal manure & trace element recommendations. Teagasc, Johnstown Castle, Wexford.

**Humphreys, J., Tunney, H. and Duggan, P.** (1996). Phosphorus loss from soils to water in the Belsgrove Catchment Co. Cavan. Cavan County Council, Courthouse, Cavan and Teagasc, Johnstown Castle, Wexford. 38 pp.

**Magette, W.L.** (1998). Factors affecting losses of nutrients from agricultural systems and delivery to water resources. Draft guidelines for nutrient use in intensive agricultural enterprises (Ed. O.T. Carton). Teagasc, Johnstown Castle, Wexford. 7 - 31.



**Reilly, M.** (1996). Meeting the challenge in the pig production industry. In: Seminar Proceedings IPC licensing for the pig and poultry production sectors: A new challenge. The Institution of Engineers of Ireland, 22 Clyde Road, Dublin 4, Ireland

**Teagasc,** (1994). Monaghan Agricultural Waste Management Study. Teagasc, Johnstown Castle, Wexford.

**Teagasc** (1994). Draft guidelines for nutrient use in intensive agricultural enterprises. Ed. O.T. Carton. Teagasc, Johnstown Castle, Wexford. 107 pp.

**Tuite, P.** (1996). The challenge in the Pig Production Sector. In: Seminar Proceedings IPC licensing for the pig and poultry production sectors: A new challenge. The Institution of Engineers of Ireland, 22 Clyde Road, Dublin 4, Ireland

**Tunney, H., Humphreys, J., Ryan, M., Murphy, W. and Carton, O.T.** (1996). Phosphorus recommendations for silage. In: Phosphorus recommendations for silage - good agronomic practice. Eds O.T. Carton, M. Ryan and W.L. Magette. Teagasc, 19 Sandymount Ave., Dublin 4.

## **A management model for pathogen abatement in animal slurry in view of its agronomic use**

*Un modèle de gestion des lisiers permettant l'abattement en pathogènes  
en vue de son utilisation agronomique.*

**G. Provolo, P. Morandi, F. Sangiorgi.**

Istituto di Ingegneria Agraria, University of Milan, Via Celoria 2, 20133 Milano, Italy -

E-mail : gprovolo@imiucca.csi.unimi.it

fsangio@imiucca.csi.unimi.it

### **Abstract**

*An important concern connected with the agronomic use of animal slurry is related to hygiene, both animal and human health. It is therefore of paramount importance to adopt techniques and operational criteria that minimise the potential risk of disease transmission. Only information related to the survival of micro-organisms during individual phases of slurry handling (storing, aerobic or anaerobic treatment, etc.) is available.*

*For this reason, we developed and evaluated a model in which the influence of the slurry management system on pathogen survival is considered (*Salmonella dublin* and *S. typhimurium*).*

*By using the model, it is possible to evaluate, taking into account the variability, the consequences of different management options. For instance, we determined that for cattle slurry with a total solids concentration of 9%, the storage period required to eliminate *S. dublin* is approximately 150 days, but it decreases to 120 days if solid-liquid separation is utilised. Although our preliminary results are very encouraging, the model needs to consider additional information on the behaviour of different micro-organisms and to be calibrated to specific conditions under which it can be utilised.*

Key words: manure handling, pathogen control, management models

### **Résumé**

Un problème important lié à l'utilisation agronomique des lisiers concerne les aspects hygiéniques, à la fois pour la santé humaine et animale. Il est par conséquent particulièrement urgent d'adopter des techniques et des critères de gestion qui minimisent le risque de transmission des maladies. Seules les informations concernant la durée de vie des microorganismes au cours des étapes particulières de gestion des effluents (stockage, traitement aérobie ou anaérobie, etc...) sont disponibles.

Nous avons donc développé et évalué un modèle dans lequel l'influence du système de gestion du lisier est relié à la survie des pathogènes (*Salmonella dublin* et *S. typhimurium*)

En utilisant ce modèle, il est possible, en prenant en compte la variabilité, d'évaluer les conséquences des différentes alternatives de gestion. Par exemple, nous avons déterminé pour le lisier bovin d'une teneur en matière sèche de 9%, que la période de stockage nécessaire pour éliminer *S. dublin* est approximativement de 150 jours, mais est réduite à 120 jours si un système de séparation liquide-solide est mis en oeuvre. Bien que nos résultats préliminaires soient encourageants, le modèle doit pouvoir incorporer d'autres informations sur le devenir des différents micro-organismes et également doit être étalonné en conditions réelles d'utilisation.

Mots-clés : gestion déjections, contrôle des pathogènes, modèles de gestion.

## 1. Introduction

There is an increasing interest in the relationship between agriculture and the environment, in particular as far as the agronomic use of animal manure and pesticides are concerned. On one hand, there is a growing demand for new research and scientifically-based advice, that is, guidelines to help farmers and agricultural advisors in their manure management choices. On the other hand, politicians seek reliable information to be able to draw up realistic regulations that can minimise the impact of agriculture on the environment.

One aspect receiving particular attention in the context of the agronomic use of animal manure is the control of hygienic conditions during the handling of animal manure.

Information on the behaviour of micro-organisms in the various handling stages (that is, separation storage, aerobic or anaerobic treatment, etc.) is now available. However, comparable information does not exist from a system's point of view. Therefore, we made an attempt to gather and link experimental data in a system representation. This led to the definition of several models able to identify the main factors that can be modified to control the hygienic aspects of farm manure handling.

## 2. Material and methods

First we devised a general model (Figure 1) describing the possible stages of manure from the animal to the field, and identifying where changes in the bacterial characteristics of the manure are possible. Secondly, we analysed the results obtained in various experiments on micro-organism survival in manure. These data were organised to clearly identify in each study the test conditions and the factors influencing survival time of the micro-organisms (Figure 2). Specifically, we

highlighted the initial concentrations of micro-organisms, temperature, total solids content, and pH of the manure on pathogen survival time. We utilised linear regression analysis in which pathogen survival time was the dependent variable and each survival factor was the independent variable to identify statistically ( $P < 0.05$ ) significant correlations. These correlations were then entered into the management model to facilitate their application to practical situations. By the way, models were devised both for swine and cattle.

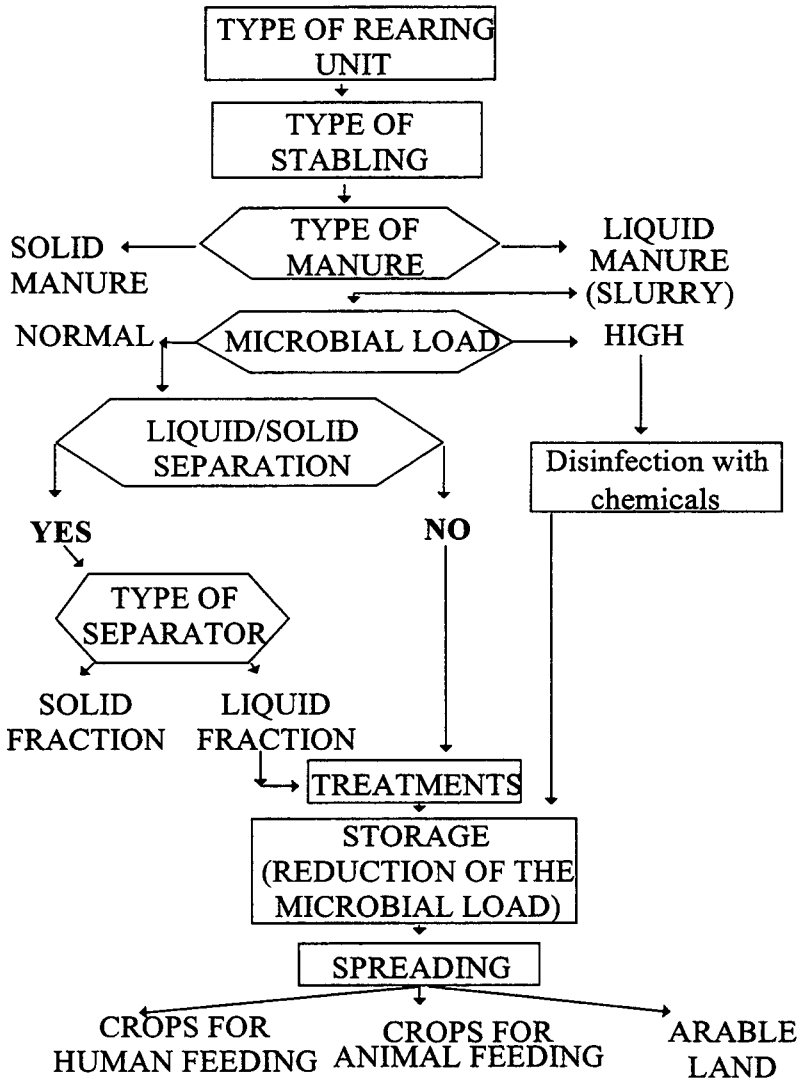

Figure 1  
General and simplified model describing the slurry cycle from production to the field

### 3. Results and discussion

Our management models are based on the analysis of the different stages of animal manure handling. Within each stage, the initial conditions (e.g. the concentration of the micro-organisms) and the values referring to factors influencing survival time or affecting pathogen concentration in manure (e.g. temperature, dry matter content, pH, duration of the handling process) can be identified. In general terms, the models define an input-output function (IOF) linking the initial conditions and the survival factors in order to evaluate the final conditions.

The final conditions of each stage of the handling process represents the initial conditions of the subsequent stage. By introducing the IOF's to describe pathogen survival at various stages of manure handling, it is possible to evaluate the hygienic state of the manure when it has to be agronomically utilised, provided that the starting conditions (i.e. the infectious state of the herd and the manure handling techniques used) are known.

To illustrate the development and use of our models we present an example based on *S. dublin* and cattle slurry in Figure 3.

Survival time (days)	Initial concentration of microorganism UFC/ml	Final concentration of microorganism UFC/ml	pH	Temperature	D.M. (T.S.)	References	Notes
132	1.000.000	0	7,4	5	4,7	39	temperature
84	55.000.000	0	6,7	5	7	55	temperature
180	1.000.000	0	7,5	10	5,2	40	sterilized+ untreated
63	6.309.573	0	7,6	5	0,4	10	disinfectants
77	1.995.262	0	7,2	5	4,5	10	uncovered
114	130.000	0	7,5	10	5,7	39	pHmin.6,5
105	150.000	0	7,5	10	5,7	39	pHmin.7
113	180.000	0	7,5	10	5,5	39	serotype HWS51
90	340.000	0	7,5	10	5,5	39	serotype HWS51

Figure 2  
Example of organization of the data collected from the various experiments

Our analysis revealed that during storage the dry matter content had the highest correlation with survival time of the bacterium, in agreement with findings reported by several researchers. The slope of the regression line shows that as slurry dry matter content increases, so does the survival time of *S. dublin* (Figure 3). On the basis of this relationship, it can be noted, for example, that in diluted slurries (dry matter contents of 1%-2%), the survival time of *S. dublin* during storage is 70-80 days, while in thicker slurries (6%-7% dry matter) survival time is about 120 days.

The same figure also contains the regression lines obtained by grouping data into three temperatures that are representative of the different seasonal conditions in temperate climates. It can be noted that with higher dry matter content, survival times at low (1-6 °C) and moderate (10 °C) temperatures tend to develop and be similar to the general regression. Larger deviations are shown with thicker slurry but with lower dry matter content and for higher temperatures (20-30 °C).

We have thus redesigned the original models to these new assumptions (Figure 4).

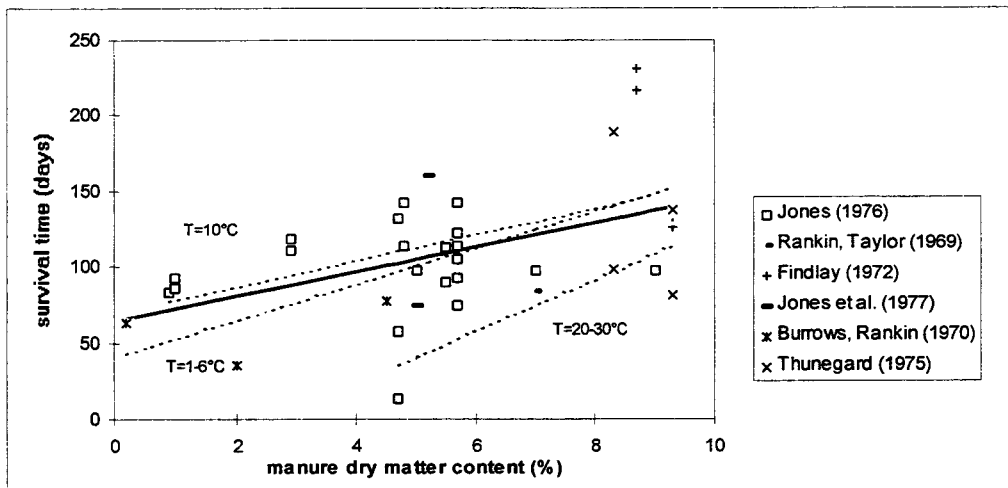
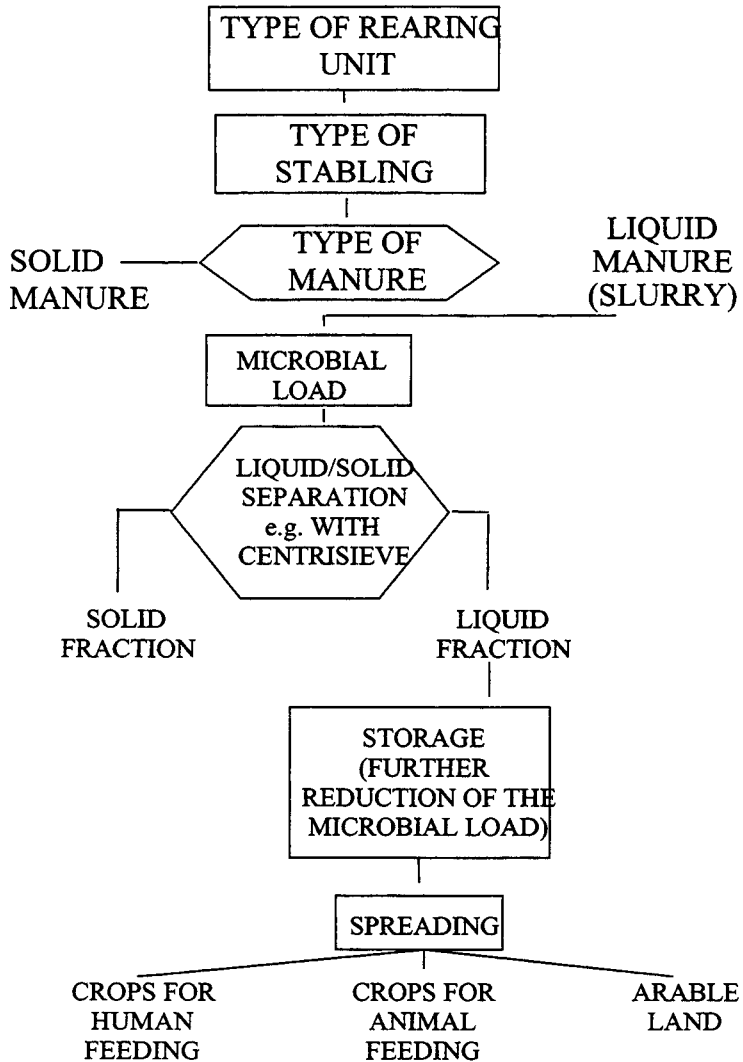

Figure 3  
 Relationship between survival time and manure dry matter content  
 for *Salmonella dublin* during storage.



*Figure 4*  
 The new model designed taking into account the factors influencing microbial survival time.

As an example of how to apply these results to practical situations, let us consider a manure handling practice in which slurry, produced by cattle on slatted floors (dry matter content approximately 9%), flows directly into a storage tank. After storage the slurry is spread on arable land. Using the relationships we developed, we would recommend that a slurry storage time of 150 days should be provided in order to reduce *S. dublin* concentrations to acceptable levels in winter. However, by using a liquid-solid separator with a 30% efficiency, the dry matter content could be decreased to 6% and, as a consequence, the storage time required to achieve an acceptable hygienic standard could be decreased to 120 days. In the summertime, the higher ambient temperatures would halve this value.

The Figure 5 also shows clearly that the models we derived can help evaluate different slurry management choices according to hygienic considerations. Such choices can have significant economic effects on investment and running costs. Obviously, it would be necessary also to check the compatibility of individual management decisions with the agronomic requirements on slurry spreading. Politicians or those in charge of environmental protection could use these results either to develop slurry management criteria, or as a basis to propose economic incentives to facilitate adoption of the criteria by farmers.

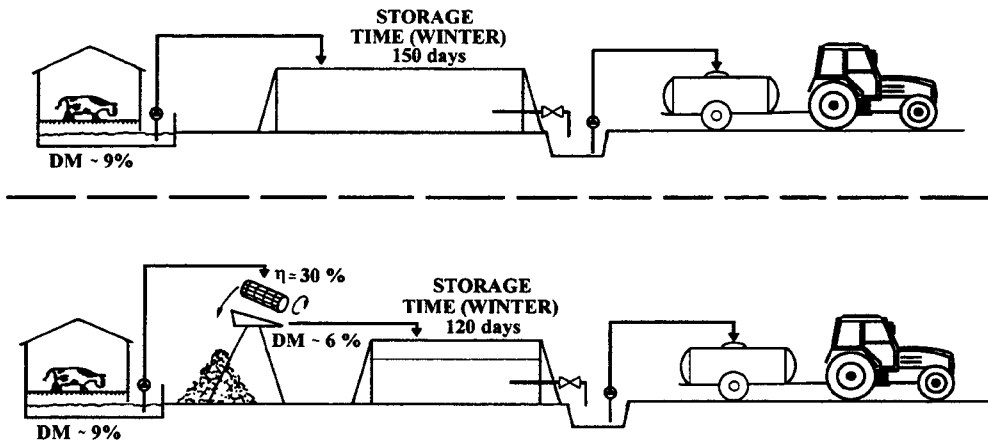

**Figure 5**  
Possible consequences on slurry management hardware derived by the use of the model devised.



## **4. Conclusions**

Despite these encouraging preliminary results, widespread implementation of the proposed management models requires further investigation to incorporate the behaviour of additional micro-organisms and to calibrate the models to the specific conditions in which they would be utilised. An extension of the models to include different kinds of pathogens (e.g. viruses, parasites, and mycetes) is also needed. Additional micro-organisms must be taken into account and a comparison with the results obtained in this study must be made in order to find management solutions able to give an overall reduction in the pathogenic load, rather than address only a specific agent. To go further in this direction, it is also necessary to consider both the risk (damage in economic terms) posed by a specific agent, and the frequency of infection events in a specific area. By following such an approach, it will be possible to take into real consideration the hygienic problems associated with animal manure management, to evaluate the possible on-site and off-site dangers resulting from the use of this material, and to devise practical methods by which to keep risks within acceptable limits.

## **5. References**

References, consisting in 76 titles, are available from the authors.

**Chairman's summary of part 1.**  
**Management strategies for organic waste use in agriculture**  
**Jeremy HALL**

Six papers were presented during the opening session on the theme of management strategies covering expert systems, modelling and legislation.

The keynote paper was presented by Dr J-M. Merillot from Ademe. This paper provided a broad over-view of legislative, economic, agronomic and environmental impact of organic wastes. It covered the concepts and principles used to build policies, as well as economic, social and technical aspects, and considered the environmental balance of benefits and impacts for wastes from the agrofood industries, municipal and agricultural wastes.

Goss *et al* described a decision support system (DSS) for manure management. Key research needs were identified through a group of stakeholders concerned about manure management, including workshops of farmers and advisors. The University of Guelph developed the first version of a computer-based DSS. This deals with all aspects of manure management, particularly the economics and environmental impacts of different systems.

Lenehan *et al* presented SWAMP (Sustainable Waste Application Management Project) which is an EC funded project under taken by seven institutes across Europe. This addressed some of the problems associated with utilising slurry and comprised three major research areas: management and risk assessment; determining the nutrient value of slurry; and the development of prototype application system.

Derikx presented a paper on the new manure legislation in the Netherlands. The aim of this is to provide further controls on nutrient additions to land where there is already a surplus of manure. This introduces the Mineral Bookkeeping System under which every farmer has to declare an annual balance of nutrients entering and leaving his farm. Where input exceeds output, a severe tax has to be paid (Dfl 10/kg P<sub>2</sub>O<sub>5</sub>).

Carton's paper (presented by Magette) discussed the implication of Irish legislation for landspreading manure from intensive agricultural enterprises. The objective is to reduce nutrient emissions and improve the balance of nutrient loads between manure and crop requirements. The consequence is that more land is required for spreading manures than has been used in the past to meet with restrictions and exclusion zones.

Provolo *et al* described the development and evaluation of a model in which the influence of different slurry management systems on pathogen survival can be estimated.

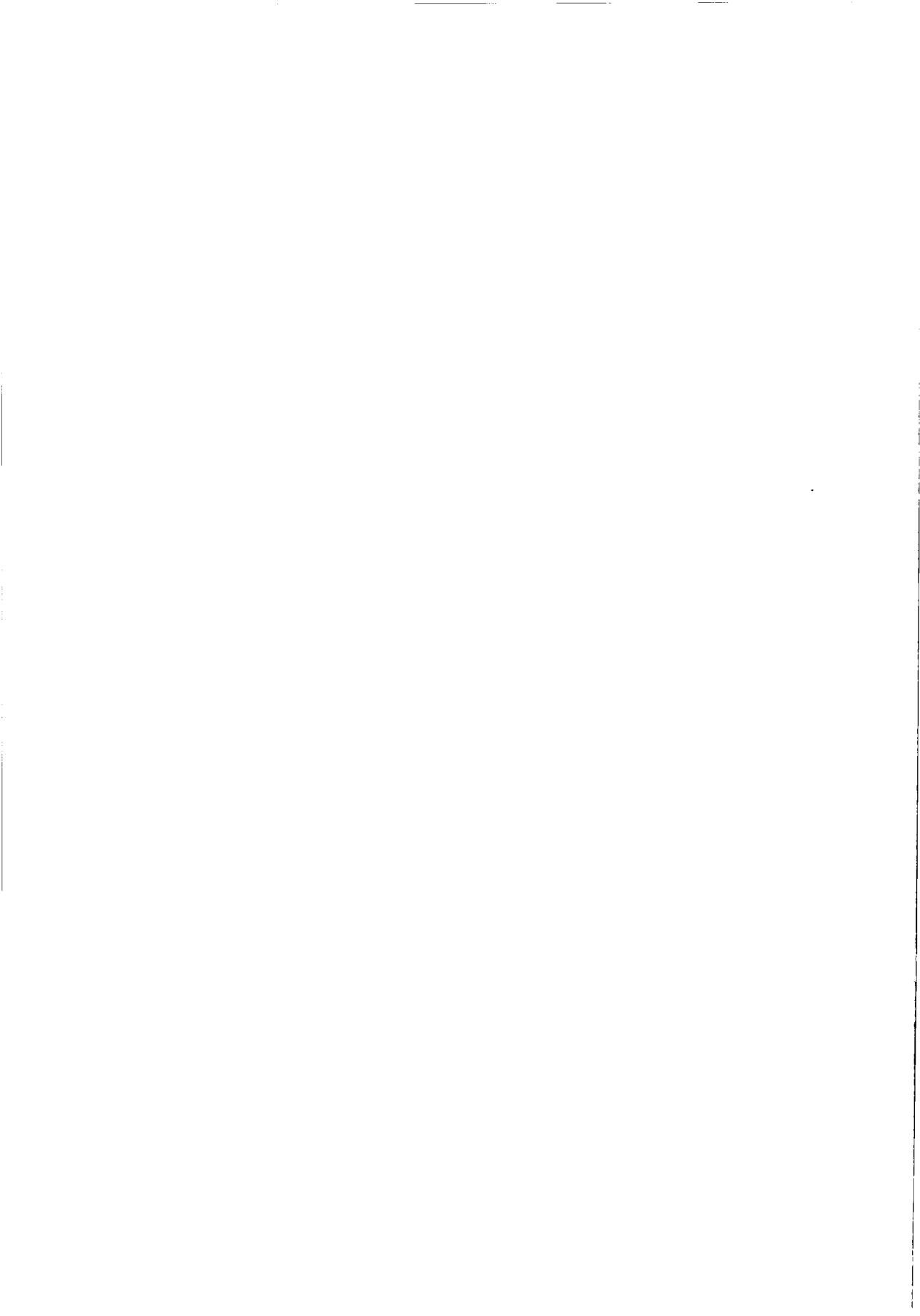

## **Part 2**

**Agronomic values of organic wastes.**

**Chairman : W. Magette (Ireland)**

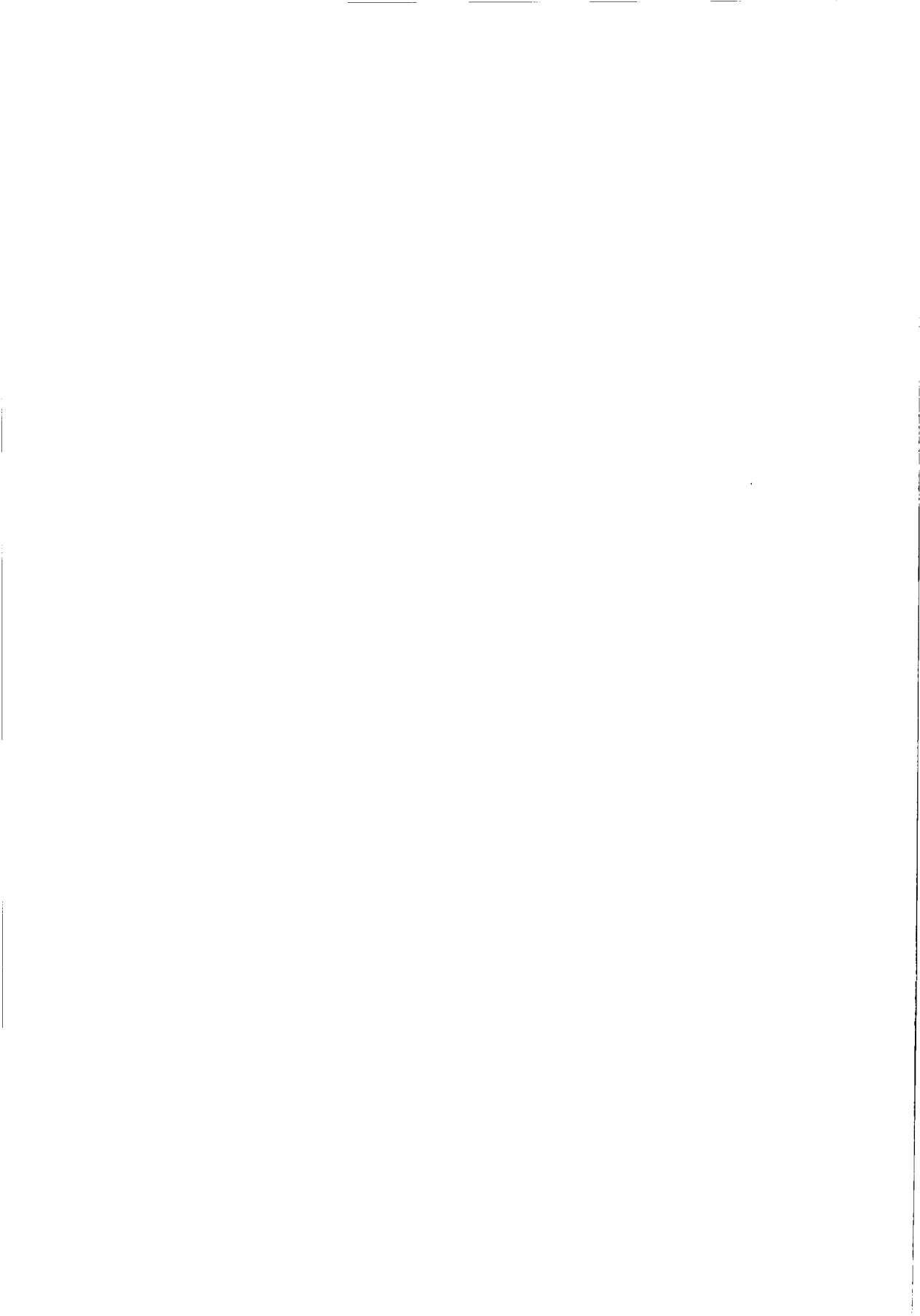

# Assessment of nutrient availability from organic wastes use in agriculture. A review.

## Invited Paper

*Estimation de la biodisponibilité des éléments nutritifs présents dans les produits organiques résiduaire.*

**Jean-Claude Fardeau<sup>1</sup>**

DEVN/LEMIR, CEA Cadarache  
13108. Saint Paul Lez Durance. France  
E-mail : Fardeau@versailles.inr.fr

## Abstract

*Organic wastes are products which, firstly, are wastes and secondly contain organic compounds, i.e. organic C and N. Except for some special organic industrial by-products, these wastes, which are farmyard manure, poultry manure, pig and cattle slurries, sewage sludges, compost and mixtures of these by-products, are derived from living processes. Therefore they contain all elements that are found in living organisms, i. e. not only C and N but also P, K, Ca, Mg and most of the microelements essential for life. Further, they also sometimes contain elements, accidentally added, which have to be considered as potentially toxic (PTEs) for life.*

*Two reasons can explain the transfer of such compounds in agricultural soils. The first is the mythic role of organic matter in soil. This mythic aspect come from the past when the farmyard manure was the only source of nutrients for crops and when it was assumed that plant growth depended on organic compounds. The second reason is that the increasing urban population wish to dispose their wastes far from their houses and so explain, to the farmers, that wastes would be very good, even essential, for crop production, as it use to be in the past. Whatever the explanations given, organic wastes return, for a part, to farmer fields which are their origin at a statistic scale.*

*An essential question concerns the effect of such compounds on crop production and the behaviour of each element of these wastes. Therefore it is of first importance to be able to characterize and quantify the availability, for crops, of each nutrient contained in the organic wastes. The main question becomes: how to characterize the availability of a given element among a lot of other elements which are added together. One of the most efficient way is the use of an isotope of the*

---

<sup>1</sup> Present adress : INRA, Département Environnement et Agronomie. Route de Saint-Cyr. F-78000 Versailles.

*element under study. As a matter of fact, when a crop takes an element in two sources (soil and wastes), labeling of one of the nutritive sources provides, in crops, the origin and the contribution to crop nutrition of the element. Experiments have been carried out with  $^{15}\text{N}$ ,  $^{32}\text{P}$  or  $^{33}\text{P}$ ,  $^{45}\text{Ca}$ ,  $^{56}\text{Fe}$ ,  $^{65}\text{Zn}$ ,  $^{109}\text{Cd}$ ,  $^{63}\text{Ni}$ , and some other tracers. Moreover, such isotopes can inform either on immediate effect of organic wastes on crops or on the residual effect of organic wastes on available nutrients in soil-plant systems.*

*In this review, examples shown concern mainly phosphorus applied as farmyard manure, slurries sewage sludges and composts whose P availability of P has been determined using isotopes. The availability of P from farmyard manure and slurries is of the same order of magnitude than that of water soluble P fertilizers. The availability of phosphorus in sewage sludges depends firstly on the industrial processes applied to polluted waters. More the water is cleaned, more the phosphorus in sludges becomes unavailable for crops. Examples are also given for other elements as zinc.*

Key-words: Organic wastes, bioavailability, isotopes, phosphorus

## **Résumé**

Les résidus organiques sont d'abord des résidus et ensuite des produits contenant des composés organiques, c'est-à-dire contenant du C et du N. À l'exception de certains sous-produits organiques industriels, les autres, tels le fumier de bovins et de volailles, les lisiers de bovins et porcins, les boues résiduaires de station d'épuration, les composts et les mélanges de tous ces produits, ont pour origine première la vie. C'est pourquoi ils contiennent l'ensemble des constituants nécessaires au fonctionnement de la vie. Mais parfois, du fait d'une addition accidentelle, ils recèlent des éléments qui doivent être considérés comme toxiques pour les organismes vivants.

Deux raisons conduisent à transférer de tels composés vers les sols agricoles. Tout d'abord le rôle mythique de la matière organique. Cet aspect mythique a pour origine l'époque où le fumier était l'unique source de restitutions des éléments nutritifs aux champs cultivés et où certains soutenaient que la matière organique était absolument indispensable à la nutrition des plantes. La seconde raison est beaucoup plus simple. Les citoyens poussent leurs déchets loin de leurs habitations et expliquent aux agriculteurs que cette matière organique est bonne, voire indispensable, pour la production agricole. Quelles que soient les raisons évoquées, des composés organiques résiduaires rejoignent les champs.

La question majeure concerne l'effet des divers éléments contenus dans ces résidus. Il est de la première importance de disposer d'outils permettant de caractériser et quantifier la biodisponibilité pour les cultures des différents éléments présents dans ces résidus. Une des méthodes les plus efficaces consiste à utiliser des isotopes traceurs des éléments. En effet, quand une culture prélève des éléments dans deux sources nutritives, le sol et le résidu, le marquage de l'une ou l'autre des sources permet de connaître, dans la plante, l'origine de l'élément. Des expériences peuvent être réalisées avec  $^{15}\text{N}$ ,  $^{32}\text{P}$ ,  $^{45}\text{Ca}$ ,  $^{56}\text{Fe}$ ,  $^{65}\text{Zn}$ ,  $^{109}\text{Cd}$  et  $^{63}\text{Ni}$ , voire avec quelques autres isotopes.

On présente, dans cette revue, des exemples concernant principalement le phosphore. La biodisponibilité du phosphore du fumier de ferme et des lisiers est très proche de celle du phosphore des engrais phosphatés solubles dans l'eau. La biodisponibilité du phosphore des boues résiduaires dépend du processus industriel de purification de l'eau : plus est « nettoyée », moins le phosphore est biodisponible pour les plantes. On présente également un exemple relatif au devenir du zinc contenu dans les lisiers.

Mots clé : résidus organiques, biodisponibilité, isotopes, phosphore.

## 1. Introduction

This conference is devoted to management strategies for **organic waste** use in order to recycle, **in agriculture**, agricultural, municipal and industrial residues. This paper is focused on assessments of nutrient bioavailability when applying organic wastes in/on soils. The words: bioavailability, nutrient, organic wastes, recycling and management structure this review.

The mythic aspect of organic matter was so strong in human subconscious that even the Vatican took time and money to organize a symposium on « Organic matter and soil fertility » (Anonymous, 1968). Nevertheless, whatever the historic, mythic and pertaining to the passions role of organic matter, it was shown by Liebig, 150 years ago that there is no need of organic matter for plant growth. Plants grow, without organic compounds, from inorganic nutrients and  $\text{CO}_2$  and they create, through photosynthetic processes, organic matter containing mineral nutrients taken in the soil as ions, the only chemical form which is metabolized; further, this organic matter as plant, or crop residue, goes back in the environment.

At the opposite, animals, and among them Man, cannot grow, and live, without organic compounds. They even cannot live without rejecting in the environment a part of the organic compounds they eat and transform by metabolic processes. There is no possible animal life without a production of organic residues. These unavoidable residues are, for example, manure, slurries, municipal residues, compost and sewage sludges. To avoid increasing amounts of organic residues



near our life place, some of them go back to their departure point: the farmer fields. But organic compounds, and inorganic nutrients included in organic compounds or in organic structures as crop residues or bacterial cells in sewage sludges, are unavailable for plants. Inorganic nutrients have to be released and made available for plants by mineralization of organic matter. Soils contain a diversity of microorganisms (Elliott and Coleman, 1988; Beare *et al.*, 1995; Brussard *et al.*, 1997) known for their ability to mineralize organic matter and, as a consequence, to release nutrients in their ionic form, i.e. available for plants (Coleman *et al.*, 1983). Therefore organic wastes can be applied on soils to be mineralized. This property of soils, with their microorganisms, was called in the past « purifying power » (Catroux *et al.*, 1974). This expression, probably imagined by a town man to justify the reject of its residues far from its home, was ambiguous and too optimistic: soil microorganisms have only a capability to transform some elements from a chemical form unavailable, potentially toxic, towards another chemical form, theoretically neutral for the environment. The too optimistic view has sometimes contributed to make the soils of farmer fields or forests a bin. When these organic wastes are transferred from towns to farmers fields concurrently to transfer of foods from fields to towns, they contribute, for a part, to the recycling of non renewable nutrients, as phosphorus or potassium, and thus to go towards a more sustainable development (Biswas, 1994).

## 2. Bioavailability and mobility of nutrients or elements concepts

Definition of bioavailability and the concept on which it is based are considered as unclear for most of the scientists of soils or agronomy (Naidu *et al.*, 1997) and still more for the regulatory authorities. **Bioavailability is the property for a nutrient to be available.** A bioavailable compound, or element, is one that can enter, whatever the mechanism of entry, into a biological cycle and whatever its contribution, or not, to the metabolism. Thus, in the context of this conference, bioavailability corresponds to the mechanisms supplying nutrients to living organisms, mainly to plants. Therefore, according to Barber (1995), an available, or bioavailable or phytoavailable, nutrient, is one that is present in a pool of ions in the soil and can move to the plant root during plant growth if root is close enough. Mobility is the ability of an element to be transferred from one compartment to another compartment of the soil-solution-plant system when bioavailability is only the property of an element to be transferred from soil compartment into the plant compartment.

Confusion between the concept of bioavailability and the measurement of bioavailability is frequent (Naidu *et al.*, 1997) and has to be avoided. Bioavailability, as shown by « ity » , indicates a potentiality, a capability for a nutrient to enter into the roots, and that, irrespective of the realization, i.e. of its extraction from soil by a plant. C as CO<sub>2</sub>, N, P K, S, Ca, Mg and the 13 micronutrients considered as essential for plant growth, according to Marschner (1995), are fully included in the

definition *sensu stricto*.. Nevertheless, bioavailability has to be considered as the property of an element, essential or not, to enter into the roots. Therefore this review is focused not only on nutrients but also on elements, such as Ni, Zn, Cr ..., potentially toxic (PTEs) for plants, animals or humans (Smith, 1996; Morel, 1997).

A soil bioavailable element has to be characterized using, at least, three factors: an intensity factor,  $I_x$  ; a quantity factor:  $Q_x$  and a capacity factor  $Cap_x$ . (White and Beckett, 1964; Barber, 1995). These factors are generally quantified using parameters derived from soil analysis. The intensity factor is the chemical potential of the element which illustrates, in the soil-plant system, the « pressure » of elements on the roots. Therefore the concentration of elements, or ions, in the soil solution is the experimental parameter generally taken as intensity factor. Concentration is the first factor accounting for the uptake of nutrients by plants roots (Barber, 1995). The quantity factor is the amount of the element which is present in the soil-solution-plant system at the chemical potential of the element in the soil solution. The capacity factor has to describe the variations of the quantity factor when the intensity factor is modified either by an uptake by roots or by an application of the element in soil.

Bioavailability concept referring to plant uptake and growth, bioavailability is a time depending characteristic. The three factors, intensity, quantity and capacity proposed in the past, do not document on release, with time, of the element from soil, i.e. on the kinetic of release. Thus, a gap, more a lack, appear between the definition taking into account time and factors utilized to characterize and quantify the nutrient bioavailability.

### **3. Bioavailability of elements. Its assessment**

A full and right assessment of bioavailability would require understanding all mechanisms governing the flux of nutrients from soil particles or components towards soil solution and further to roots (Barber, 1995). Unfortunately, at the present time, only some of these mechanisms are known (Loneragan, 1997). In soil plant systems, nutrients, and probably other elements, enter into the plants as ions. Ions exist only in water: soil solution is the obligatory way for nutrients between soil particles and roots. Therefore analysis of particular properties of elements in the soil solution can document on the behavior and the bioavailability of nutrients.

#### **3.1. Where and when assess the nutrient availability with organic wastes ?**

When applying, on/in soils, an organic waste containing available elements, plants take the element from the two sources available for plants: that of the native soil and that of the organic waste. In such case, bioavailability of an element can be assessed in: (i) the waste, (ii) the soil, (iii) the soil-waste mixture. Two reasons

justify that there is no universal response face these three possibilities. Firstly parameters describing bioavailability are not additive; secondly, whatever the waste applied to soil, most of the components added react with soil particles and components. These reactions can modify simultaneously the bioavailability of the added nutrient and that of the native nutrient. Therefore, the most efficient choice is often the analysis of bioavailability of elements in the soil-waste mixture and to compare further this availability to that of the element in the soil alone.

### **3.2. Bioavailability : methods of assessment**

Whatever the element, there is no significant correlation between the total content of an element in the soil and the amount taken up by crops during a growing season: uptake depends, for a part, on the bioavailability of the element. This fact shows that each element is present in soils with many physico-chemical forms, many species, and justifies research need on element speciation. The most exiting, and promising, speciation is that allowing to distinguish between available and unavailable forms of element.

To choose, and to continuously improve, methods of assessment of bioavailability, the following established mechanisms have to be kept in mind:

1. Nutrients enter into plant roots only as ions.
2. Nutrient uptake depends on time.
3. Excepted for C, N and S, behavior of inorganic nutrients and elements depends on physical processes as adsorption-desorption and on chemical mechanisms as precipitation-dissolution and organic synthesis.
4. Behavior of nutrient as C via CO<sub>2</sub>, N and S, depends especially on soil microorganisms activity. Thus, mechanisms by which organic compounds are transformed into inorganic compounds are biological processes and are controlled by all the factors modifying metabolism and growth of soil microorganisms. These soil factors are water and oxygen content, temperature, content in energy sources, i.e. in organic compounds available for microorganisms.

#### ***a) Chemical, or physical, extraction***

This approach, the most common to assess bioavailability, is that of routine analysis. It was imagined in 1845 (Daubeny). Such approach is based on successive assumptions: (i) a chemical reactant could extract specifically a define physico-chemical form; (ii) the form extracted is available, or unavailable; (iii) there is a significant correlation between the quantity of element taken up by a crop and the quantity of P extracted by the chemical. The conceptual limits of such approach are well known: (i) only one factor among the three required, the quantity factor, is determined using extraction methods; (ii) chemical extractions modified the adsorption properties of soil particles and thus modified the behavior of the element during the extraction procedure, resulting in various pitfalls (Nirel and Morel, 1990);

(iii) chemical extractions are less selective than expected. For example, when using a basic extractant, the simultaneous extraction of the element and organic matter is a well known problem ; (iv) Such speciation is a « photography » of the status of the element at a given time; a photography is a static representation and can never document on the evolution, with time, of the system. Nevertheless, chemical extractions continue to be utilized in soil routine analyses for almost all the elements.

### ***b) The isotopic exchange method***

1. **Theory.** As extraction procedures significantly modify the adsorption properties of soil components, they give, finally, wrong conclusions concerning the amounts of available nutrients. Thus it was of first interest to develop, for bioavailability assessment, experimental procedures without extraction procedure. This can be reached using **isotopic exchange kinetic method.**

The aim of this method is to determine size and kinetic properties of a pool, or compartment, of an element in a pluricompartamental system without extracting compartments (Shipley and Clark, 1972; Frossard and Sinaj, 1997). Schematically, the method consists, taking into account some theoretical and practical constraints to maintain the system under analysis in steady state, in applying an isotopic tracer in a given pool and to measure, **with time**, how it leaves the pool. The mathematical analysis of the kinetic of the isotope transfer, i.e. the decrease with time of the amount of radioactivity in the pool where the radioactivity was introduced, documents on the organization of exchangeable ions and on their ability to move from one pool to another pool (Shipley and Clark, 1972).

2. **Results.** Such a procedure was performed for phosphate ions in soil solution systems in steady state or in soil-soil solution-plant systems. The following conclusions were obtained :

⇒ Analysis of isotopically exchangeable phosphate ion kinetics shows that isotopically exchangeable P is made of many compartments. Each compartment of phosphate ions is characterized by its ability, its mean mathematical time, to be released from the soil particles into the soil solution. The compartments are organized as a mamillary system: a central pool, made for a part of the ions in the soil solution, exchange phosphate ions with all the other pools, each with a kinetic rate of transfer towards the soil solution (Fardeau *et al.*, 1996)

⇒ Thus, isotopically exchangeable P can be described using its intensity factor: the concentration of orthophosphate ions in the soil solution expressed in  $\text{mgP L}^{-1}$  and its quantity factor: the amount of instantaneously isotopically exchangeable P, expressed in  $\text{mgP kg}^{-1}$ , and determined in routine analysis as the amount of P which is isotopically exchangeable in 1 minute. As a consequence, the capacity factor, which is the ratio of the quantity factor to the intensity factor, is expressed in

$L \text{ kg}^{-1}$  : it documents on the maximum volume of solution which can be added to soil without variations of the concentration. It was shown that, for a given soil, there is a stable relation between the quantity factor,  $Q$ , and the intensity factor,  $I$  (Morel *et al.*, 1995). The general equation linking  $Q$  to  $I$  is a power function:  $Q = \alpha I^\beta$

⇒ More, comparing the isotopic composition of phosphate ions in the soil solution and that of P in crops grown on soils where the isotopically exchangeable phosphate ions were labeled, it was shown that the soil isotopically exchangeable P is the only P source for plant nutrition, i.e. is the available soil P (Morel and Plenchette, 1994). Thus parameters characterizing isotopically exchangeable P can also be utilized in order to characterize available soil P.

⇒ Finally, the isotopic exchange kinetic method allows to reach the three required factors. It add a supplementary factor, the time factor, which is essential for plant nutrition. This time factor can be expressed either in terms of compartments whose the ability to leave the solid phase in order to enter into the soil solution is time depending, either in terms of a mean rate of transfer from soil to soil solution expressed in  $\text{mgP mn}^{-1} \text{ kg}^{-1}$ . Thus it is shown that there is no true border between available and unavailable nutrient: there is a continuum between instantaneously available soil P and really slowly available soil P.

**3. Extension of the method and the concept to other elements.** The same procedure was applied, in soil-solution systems and in soil-soil solution-plant systems, to potassium, iron, nickel and zinc ions (Frossard and Sinaj, 1997; Echevarria *et al.*, 1997). Conclusions derived from experiments were similar to that obtained for soil phosphate.

**4. Conclusion on isotopic exchange procedure.** At the opposite to the extraction methods which know borders, the isotopic exchange method which is based on an universal and unavoidable physical process, the **Brownian motion**, had no border. At the present time, there is no experimental and theoretical evidence that these results can be extended to all nutrients and elements whose behavior in soil-plant systems is mainly controlled by physico-chemical processes. Nevertheless, there is also no reason which can proof the opposite. This approach can be considered as a universal one (Naidu *et al.*, 1997) and thus a reference method which could be utilized to test the capability of extraction methods to extract, from soils, really available soil elements.

### **3.3. Assessment of the contribution of organic wastes to availability of a given nutrient**

Organic by-products as sewage sludges, farmyard manures or pig slurries applied in soils can increase bioavailability of elements because they contain available nutrients or nutrient which can be made available following organic compound mineralization. But organic compounds can also modify availability because some

of them, and sometimes mineral compounds as calcium oxide added to wastes, modify mineralization rates and processes (Thien and Myers, 1992) or the ability of soils to fix, or to release, the native nutrients. In such situations the contribution of each source to the total element uptake cannot be determined with field, or pot, experiments and measuring element uptake. The only way to determine the contribution of each source, wastes or soil, is the labeling of one of the two available sources: that of the soil or that of the wastes (Fardeau *et al.*, 1996). As isotopically exchangeable ions in a soil-plant system are the available soil ions, the labeling can be made using isotopic exchange (Fardeau *et al.*, 1996). In order to avoid pot experiments with isotopes, which are always time and money consuming, the contribution of the two source can be obtained, after labeling of one of the two sources, analyzing the isotopic composition of the element in the soil solution. This method can be applied to forecast the contribution of P applied to a soil to the P nutrition of crops (Morel and Fardeau, 1991).

### **3.4. Case studies**

Organic wastes are the main scope of this conference. Due to their very large varieties, as they are issued: (i) from agriculture as crop residues, farmyard manure, slurries, (ii) from towns as rough residues compost or sewage sludges derived from a lot of different treatments, (iii) from industry as ashes of wood, and to the number of essential nutrients, about 20 (Loneragan, 1997), an exhaustive list of results is impossible (Sharpley and Smith, 1995 ; Bril and Salomons, 1990). Some examples are presented below.

#### **a) Potassium.**

Potassium ions never link with organic compounds, except for example with an organic chemical reactant called tetraphenilboron. Thus, potassium is present as its ionic form in most of organic wastes, as crop residues, composts, sewage sludges, slurries (Bernal *et al.*, 1993a; Martinez, 1994) urine and farmyard manure. Thus, when the wall cell of living organisms become porous at death, potassium is released in the soil solution (Japenga and Harmsen, 1990). Therefore potassium applied with organic wastes has to be considered as a K fertilizer (Castillon, 1994), and can be, for a part, leached (Martinez, 1994) when applications are significantly greater than the needs of plants. It has to be also repeated to farmers that straw, or crop residues as sugar beet leaves, are the first K fertilizer for the following crop which has to be taken into account in the balance of the agrosystem.

#### **b) Phosphorus**

P can be a limiting factor for crop yields on soils and, at the opposite, P is also involved in eutrophication processes in surface water. P is a non renewable resource and has to be recycled. Therefore P is one nutrient which has been intensively studied. The main results are summarized as follows:

- *P in crop residues*: The percentage of utilization of P included in crops residues is of the same order or slightly higher than that of water-soluble

P fertilizers. Thus the amount of P in crop residues has to be taken into account in balances of nutrients at field, farm or country scales.

- *P in animal wastes*: P contained in animal wastes is due to feeds which contain inorganic phosphate and Ca-Mg phytate, an organic compound (Cromwell, 1992). The major part of P absorbed by animals is rejected on the same chemical form. Nevertheless, in soils which received animal organic wastes, only inorganic phosphate content increases (Robinson *et al.*, 1995). Phytate is often quickly hydrolyzed by soil microorganisms with exo-enzymes and inorganic phosphate is released. As a consequence, availability of P in animal wastes is of the same order of magnitude as that of P in water-soluble P fertilizers (Bernal *et al.*, 1993b). Thus the amount of P to be applied, as animal wastes, for crop production has to be, at year scale, no greater than that applied as P fertilizer. When P is applied, as animal wastes, in amounts significantly higher than that taken up by crop, the content of available soil P increases drastically, whatever the soil type (Coppenet *et al.*, 1993; Fardeau et Martinez, 1996).
- *P in sewage sludges*: P availability in sewage sludges depends on the industrial processes of obtaining sludges. In biological sludges, P which is included in bacterial cells, is available as phosphorus in all residue derived from living organisms. When successive treatments as iron or aluminum chloride addition, and/or heating for sterilization, occur the concentration of phosphate ions in sludge solution decreases; and simultaneously P bioavailability in sewage sludges decreases: P can become almost unavailable for plants. There is, for 10 years,, an increase of P content in sludges which results of increasing dephosphatation processes using chemicals; but simultaneously P availability for plant decreases. At the present time, we have to choose between a water clean after sludge production where the risk of eutrophisation is really limited with a decreasing P availability in sludges with less interest for its recycling and, at the opposite, a high P availability in sludges and a high risk of water eutrophisation. This case shows the struggle of interests between surface waters and cropped fields.
- *P in composts and municipal refuses*. P availability in composts is generally lower than that of P in sewage sludges (Faisse, 1996).
- *P in industrial wastes*. Wood is sometimes utilized to produce heat and/or energy, for example in paper paste industry. In such case, P, and K, are found in ashes. P availability, due to the heating which transform free phosphate ions into little soluble P, is very low.
- *P in bones*. Bones are also derived from living organisms and have been the first P fertilizer recognized. But the availability of P in bones is very low: phosphate ions are included in very well crystallized apatite. Further bones were collected to be dissolved with sulfuric acid. It was the birth of water soluble phosphate fertilizer industry.

However that may be, P availability decreases when the time of contact between soil components and P applied as organic wastes increases, similarly to inorganic P fertilizers (Larsen, 1974).

### **c) Nitrogen**

Nitrogen of organic wastes is unavailable for plants; but **it becomes phytoavailable following microbial mineralization**. The rate of mineralization, which depends on a lot of factors, controls the behavior of organic nitrogen in soils and its transformation into phytoavailable N.  $^{15}\text{N}$ -isotope was sometimes utilized in order to follow the behavior of organic nitrogen derived from sludges and other organic residues (Fardeau *et al.*, 1976; Béline *et al.*, 1998). Recently, this isotope was utilized in order to determine, with pig slurry, the contribution of two very important processes, ammonia volatilization and denitrification, to the biogeochemical cycle of nitrogen (Chadwick *et al.*, 1998): applying « N pig slurry » on soils in June and October, about 6 % were volatilized, 23 % became in  $\text{N}_2\text{O}$ , a pollutant gas and 12 % turned into  $\text{N}_2$ .

### **d) Microelements**

The fate of micronutrients, and some of microelements, the potentially toxic elements (PTEs), is studied due to potential risks for living organisms (Morel *et al.*, 1997). It was explained that organic matter either fixes heavy metals and make them unavailable or, at the opposite, that microelements are released more easily than without addition organic compounds (Smith, 1996). It was shown, for example that applications of biosolids as sludge (Sloan *et al.*, 1997) and heavy applications of pig slurries increased significantly Cd, Zn and Cu which are extractable using various chemicals (Coppenet *et al.*, 1993; L'Herroux *et al.*, 1997). But even when amounts of microelements extracted by a chemical increases, the element uptakes can be unvarying (Cabral *et al.*, 1998). But, with such an experimental procedure, there was no mean to assess the contribution of sludges to the variations of availability of elements and to determine the causes and the origin of such increases: increasing mobility and availability of native elements in soils or uptake of these elements from applied pig slurries.

Isotopes were also utilized to study the fate of PTEs (Fardeau *et al.*, 1976). Whatever regulation difficulties, often more difficult to solve than safety precautions ! to carry out experiments with gamma-emitter isotopes, the isotopic exchange method could quickly provide knowledge on the fate of such elements whose chemical speciations and measurements are always difficult and time consuming (Echevarria, 1996; Echevarria *et al.*, 1997). Thus, when applying this isotopic method in soil samples taken in experimental field which received heavy applications of slurries, it was shown that the amounts of directly available Zn increased (Frossard and Sinaj, 1997). Generally the capacity factor of soil for a given ion decreases when the amount of instantaneously available nutrient increases. But, in this soil the capacity factor for Zn ions increased though amount of available Zn increased. In this long term field experiment a liming increased more the capacity factor for Zn than the Zn application with slurry decreased the capacity factor. Finally, as for P (Morel *et al.*, 1994), some agricultural management



practices can modify the fate of microelements more than an application or an uptake of these microelements.

#### 4. Management strategies and needs for the future

In the past, the « town Man » move away its organic wastes and its personal residues, balance of his metabolism, sometimes towards the farmer fields, sometimes towards the rivers ! firstly far from its home. This ancestral management practice was the first « natural » recycling. At the present time at the earth scale, resources necessary for food production have shown a disquieting deterioration (Biswas, 1994). Some of these resources, as phosphorus, are non renewable element at the Man life scale. Therefore, a recycling, through soils, of most of our organic wastes, which contain more of the inorganic nutrient taken in soil with food harvests, has to be recommended. Interesting fact: this « disposal and removal » method has the lower cost ! But for some elements, as most of the PTEs, their contents in waste dry matter are higher than in soils. In such case, their total contents in soil increase.

Assessment of phytoavailability of elements would required understanding of mechanisms involved in transfer from soil components to roots (Barber, 1995)..Applying this comment to organic wastes, the problem could be summarized as follows :

1. These wastes contain organic and inorganic components.
2. The behavior of inorganic compounds is the same than that of mineral fertilizers and depends on the result of the competition between soil and plants for the nutrients.
3. In the context of this symposium only organic part of wastes is examined. Able to transform organic compounds into inorganic nutrients, **soil microorganisms are the key for recycling** (Coleman *et al.*, 1983; Elliott and Coleman, 1988; Kucey *et al.*, 1989; Thien and Myers, 1992; Brussard *et al.*, 1997).To become available, elements present in organic wastes have to be firstly released from biological structures, as cells, or/and hydrolyzed. This step can be, at the first year scale following the application, a limiting factor for nitrogen release but most of the other inorganic elements remain finally most available for crops than those applied as mineral fertilizers.

Could an accurate availability assessment of nutrient and microelements improve management policies of organic wastes ? We have to said: YES. The bioavailability concept is now well known and the isotopic exchange method gives life to the concept and makes the knowledge on nutrient bioavailability increases. It was shown that there is a continuum from available to unavailable nutrient. Nevertheless : (i), methods of soil routine analysis utilized to transform the bioavailability concept into reality are scarce; (ii) there is a continuous difficulty for

Man to modify its thinking habit: its is easier to speak on a quantity that to speak on ability for an element to be released from soil, with time. An evolution of methods applied to document on bioavailable elements, using new concept and knowledge have to be introduced in the routine analysis methods, is now required to improve fertilizer and wastes management. This is the first need for the future.

Have organic wastes, because they contain plant nutrients known as non renewable resources, to be applied in soils when the amounts and the availability of nutrients in soils can easily satisfy the plant needs ? The better response could be probably: NO. In such cases, such management practices result, for example, in nitrate pollution by leaching (Cheverry, 1992) in ground waters and in nitrogen and phosphate pollution in surface waters by run-off (Robinson *et al.*, 1995). These facts mean that management policies of organic wastes, whatever their origins, have to take into account, not only availability of nutrients in the wastes, but also their availability in soils. This could be a second need which concerns mainly developed countries.

## 5. References

**Anonymous** (1968) Study week on organic matter and soil fertility. Pontificia Academia Scientiarum. John Wiley. New-York.

**Barber SA (1995)** Soil nutrient bioavailability. A mechanistic approach. John Wiley and Sons, New-York.

**Beare MH, Coleman DC, Crossley DA, Hendrix PF, Odum EP (1995)** A hierarchical approach to evaluating the significance of soil biodiversity to biochemical cycling. *Plant and Soil*, 170: 5-22.

**Béline F., Martinez J, Mraol C, Guiraud G (1998)** Nitrogen transformations during anaerobically stored 15N-labelled pig slurry. *Bioresource Technol.* 64, 83-88.

**Bernal MP, Lax A, Roig A (1993a)** The effect of pig slurry on exchangeable potassium in calcareous soils. *Biol. Fert. Soils*, 16:169-172.

**Bernal MP, Roig A, Garcia D (1993b)** Nutrient balances in calcareous soils after application of different rates of pig slurry. *Soil Use and Management*, 9, 1, 9-14.

**Biswas MR (1994)** Agriculture and environment: a review, 1972-1992. *Ambio*, 23, 3, 192-197.

**Bril J, Salomons W (1990)** Chemical composition of animal manure: a modelling approach. *Neth. J. Agric. Sci.*, 38, 333-351.

**Brussard L et al.**, (1997) Biodiversity and ecosystem functioning in soil. *Ambio*, XXVI, 8, 563-570.

**Cabral F, Vasconcelos E, Cordovil CMdS** (1998) Effects of soil phase from pig slurry on soil and wheat micronutrient's content. See this proceedings.

**Castillon P** (1994) Contribution des apports organiques à la fertilisation phosphatée et potassique des prairies. *Fourrages*, 139, 279-292.

**Catroux G, Germon JC, Graffin Ph** (1974) L'utilisation du sol comme système épurateur. *Ann. Agron.*, 25, 2-3, 179-193.

**Chadwick DR, Van der Weerden, Martinez J, Pain BF** (1998) Nitrogen transformations and losses following pig slurry applications to a natural soil filter system (Solepur process) in Brittany, France. *J. agric. Engng. Res.*, 69, 85-93.

**Cheverry C** (1992) Les pollutions sur le terrain : l'exemple de la Bretagne. *C. R. Acad. Agric. Fr.*, 78, 7, 57-64.

**Coleman DC, Reid CPP, Cole CV** (1983) Biological strategies of nutrient cycling in soil systems. *Adv. Ecol. Res.*, 1-55.

**Coppenet M, Golven J, Simon JC, Le Corre L, Le Roy M** (1993) Evolution chimique des sols en exploitation d'élevage intensif : exemple du Finistère. *Agronomie*, 13: 77-83.

**Cromwell GL** (1992) The biological availability of phosphorus in feedstuffs for pigs. *Pig news and information*. 13, 2, 75N-78N.

**Daubeny** (1845) On the distinction between the dormant and active ingredients of the soil. *J. R. Agric. Soc. England*. 7: 237-245.

**Echevarria G** (1996) Contribution à la prévision des transferts sol-plantes des radionucléides. Thèse INPL. Nancy.

**Echevarria G, Klein S, Fardeau JC, Morel JL** (1997) Mesure de la fraction assimilable des éléments en traces du sol par la méthode des cinétiques d'échange isotopique : cas du nickel. *C R Acad. Sci. Paris*, t.324, série II a, 221-227

**Elliott ET, Coleman DC** (1988) Let the soil work for us. *Ecological bulletins*, 39: 23-32.

**Faïsse C** (1996) Approche de la valeur fertilisante phosphatée des composts. Mémoire Ingénieur Agronome. INPL-ENSAIA Nancy.

**Fardeau JC, Guiraud G, Marol C (1996)** The role of isotopic techniques on the evaluation of the agronomic effectiveness of P fertilizers. *Fert. Res.*, 45: 101-109.

**Fardeau JC, Guiraud G, Jappé J, Llimous G (1976)** Epandages de boues résiduelles : répercussions sur l'azote du sol et le prélèvement par du ray-grass de Cd, Cr, Hg et Zn. *In: Soil organic matter studies. IAEA/SM-211/75. Wien.* pp 259-264.

**Fardeau JC, Martinez J (1996)** Epandages de lisiers : conséquences sur le phosphore biodisponible et sur la concentration de quelques cations dans la solution du sol. *agronomie*, 16, 153-166.

**Frossard E, Sinaj S (1997)** The isotope exchange kinetic technique: a method to describe the availability of inorganic nutrients. Applications to K, P, S and Zn. *Isotopes, Environ. Health Studies.* 33: 61-77.

**Japenga J, Harmsen K (1990)** Determination of mass balances and ionic balances in animal manure. *Neth. J. Agric. Sci.*, 38, 353-367.

**Kucey RMN, Janzen HH, Leggett ME (1989)** Microbially mediated increases in plant available phosphorus. *Adv. Agron.*

**Larsen S (1974)** *Food. Neth. J. agric. Sci.*, 22, 270-274.

**L'Herroux L, Le Roux S, Appriou P, Martinez J (1997)** Behaviour of metals following intensive pig slurry applications to a natural field treatment process in Brittany (France). *Environmental pollution.* 97,2, 119-130.

**Loneragan JF (1997)** Plant nutrition in the 20th and the perspectives for the 21st century. *Plant Soil.* 196: 163-174.

**Marschner H (1995)** Mineral nutrition of higher plants. Acad Press. New-York.

**Martinez J (1994)** Nutrient accumulation in soil from intensive pig slurry applications. *In: Animal waste Management. Escorna network. Hall JE (ed) FAO, Rome* pp. 129-135.

**Morel C, Fardeau JC (1991)** Phosphorus bioavailability of fertilizers: a predictive laboratory methods. *Fert. Res.*, 28: 1-9.

**Morel C, Plenchette C (1994)** Is the isotopically exchangeable phosphate of a loamy soil the plant available P ? *Plant Soil*, 158: 287-297.

**Morel C, Blaskiewicz J, Fardeau JC (1995)** Phosphorus supply to plants by soils with variable phosphorus exchange. *Soil Science.* 160, 6, 423-430.

**Morel C, Tiessen H, Moir JO, Steward JWB** (1994) Phosphorus transformations and availability under cropping and fertilization assessed by isotopic exchange. *Soil Sci Soc. Am. J.*, 58: 1439-1445.

**Morel JL** (1997) Bioavailability of trace elements to terrestrial plants. In: *Soil Ecotoxicology*. Tarradas J, Bitton G, Rossel D (eds). Lewis Publishers. New-York. pp. 141-176.

**Morel JL, Bitton G, Schwartz C, Schiavon M** (1997) Bioremediation of soils and waters contaminated with micropollutants: which role for plants ? In: *Ecotoxicology: responses, biomarkers and risks assessment*. SOS publications, Far Haven, NJ, USA. pp. 37-74.

**Naidu R, Rogers S, Gupta VVSR, Kookana RS, Bolan NS, Adriano D** (1997) Bioavailability of metals in the soil-plant environment and its potential role in risk assessment: an overview. In: *Fourth conference on the Biochemistry of trace elements*. Clark Kerr Campus, Berkeley, Ca. USA. pp. 757-758.

**Nirel PMV, Morel FMM** (1990) Pitfalls of sequential extractions. *Wat. Res.*, 24, 8, 1055-1056.

**Robinson JS, Sharpley AN, Smith SJ** (1995) The effect of animal manure applications on the forms of soil phosphorus. Steele K (ed) In: *Animal waste and the land-water interface*. CRC-Lewis Publishers New-York pp. 43-48.

**Sharpley AN, Smith SJ** (1995) Nitrogen and phosphorus forms in soils receiving manure. *Soil Science*. 159, 4, 253-258.

**Shipley A, Clark RE** (1972) Tracer in vivo kinetics. Theory and applications. Academic press. New York.

**Sloan JJ, Dowdy RH, Dolan MS, Linden DR** (1997) Long-term effects of biosolids applications on heavy metal bioavailability in agricultural soils. *J. Environ. Qual.*, 26: 966-974.

**Smith SR** (1996) Factors influencing the bioavailability of PTEs to crop plants. In: *Agricultural Recycling of sewage sludge and the environment*. Cab International. Oxon. UK. pp. 59-79.

**Thien SJ, Myers R** (1992) Determination of bioavailable phosphorus in soil. *Soil Sci. Soc. Am. J.*, 56: 814-818.

**White RE, Beckett PHT** (1964) Studies on the phosphate potential of soils. III. The pool of labile inorganic phosphate. *Plant Soil*, 21: 253-282.

## Field studies of farm manure organic nitrogen mineralisation

*Etude au champ de la minéralisation de l'azote organique des déjections animales.*

**J.R. Williams**

ADAS Boxworth, Battlegate Road,  
Boxworth, Cambridge, CB3 8NN. UK.  
E-mail : John\_Williams@adas.co.uk

**B.J. Chambers, A. Bhogal**

ADAS Gleadthorpe, Meden Vale,  
Mansfield, Notts. NG20 9PF. UK.

**D. Chadwick, B.F. Pain**

IGER North Wyke, Okehampton  
Devon, EX20 2SB. UK.

### Abstract

*Field experiments and pot incubation studies were used to quantify nitrogen (N) mineralisation from the organic fraction of farm manures. A methodology was developed to 'strip' manures of their readily available N contents to reduce the masking effects of readily available N on mineralisation measurements. In the pot incubation study the greatest N mineralisation was from a layer manure (55% of total organic N applied) and a pig slurry (37%), and least from a dairy slurry (2%) and beef FYM (6%). The amount of organic N mineralised was inversely related to the carbon:organic N ratio of the manures ( $P < 0.01$ ). Results from the 3 field experiments on contrasting soil types were in general agreement with the pot incubation studies with the largest amount of mineralisation occurring on the layer manure and pig slurry treatments and least following cattle slurry and FYM additions. Models that predicted between 10 and 20% of manure organic N would mineralise in the season following application provided the best agreement with field measurements, although none of the models successfully predicted mineralisation differences between manure types.*

Key words: Farm manures, organic nitrogen, mineralisation, modelling

### Résumé

Des essais au champ ainsi que des incubations en pots ont été utilisés pour quantifier la minéralisation de la fraction azote organique des déjections animales. Une méthode a été développée pour « appauvrir » les déjections de leur fraction azote minéral disponible afin d'éviter les interférences sur les mesures de minéralisation. Dans les essais d'incubation en pots, le taux maximum de minéralisation est obtenu à partir du fumier de volailles (55% de l'N organique total apporté) et du lisier de porc (37%), alors que des taux plus faibles furent obtenus

- avec le lisier bovin (2%) et le fumier bovin (6%). La quantité d'azote organique minéralisé est inversement corrélée au ratio carbone sur azote organique des déjections ( $P < 0.01$ ).

Les résultats issus de 3 essais au champ sur des sols différents confirment les observations en laboratoire. Les modèles qui prédisent qu'un taux de minéralisation compris entre 10 et 20% sera obtenu au cours de la saison suivant l'épandage corroborent les résultats obtenus au champ, mais ne permettent toutefois pas d'expliquer les différences entre les différents types de déjections.

Mots-clés : Déjections animales, azote organique, minéralisation, modélisation.

## 1. Introduction

In the UK, applications of animal manure to agricultural land supply ca. 450,000 tonnes of nitrogen per annum, of which ca. 300,000 tonnes are estimated to be present as organic N and ca. 150,000 tonnes in readily plant available N forms (principally ammonium and uric acid-N). Typically, 75-90% of the total N content of straw-based farmyard manures (FYM) is present as organic N, 50-60% for poultry manures and 40-50% for slurries (MAFF, 1994).

Research in the UK has largely focused on readily available N forms as these have the greatest influence in the short-term on crop fertiliser N supply, ammonia volatilisation and nitrate leaching losses (Jarvis and Pain, 1990; Unwin et al., 1991; Chambers et al., 1997). In the longer-term, organic N mineralisation will have increasingly important effects on N supply, particularly in situations where repeated manure applications are made to land. If mineralisation of the applied organic N occurs during periods of crop growth (spring-summer) fertiliser N requirements will be reduced, but if mineralisation occurs during the autumn-winter period, nitrate leaching and denitrification losses are likely to increase.

This paper describes results from pot incubation and field studies to quantify N mineralisation from the organic fraction of farm manures. Mineralisation measurements at the field sites were compared with values predicted by selected manure N models.

## 2. Methodology

Quantifying organic N mineralisation is complicated by the presence of often large quantities of readily available N (principally ammonium-N and for poultry manures, uric acid -N). Methodologies involving sedimentation (for slurries) and controlled drying were developed to "strip" the manures of their readily available N contents. The techniques were effective for the pot incubation studies (17 manure samples)

and field experiments (9 manure samples) at reducing the readily available N content of the cattle manure samples to < 1% and < 5% of total N, for the pig manure samples < 2% and < 10%, and for the poultry manure samples < 3% and < 10%, respectively.

## **2.1. Pot incubation studies.**

N mineralisation from the organic N fraction of 17 manures (3 cattle slurry, 3 cattle FYM, 3 pig slurry, 4 pig FYM and 4 poultry manures) was measured under uniform conditions of light (16 hour photo period), temperature (18°C days and 12°C nights) and soil moisture status (60% of moisture holding capacity) for a period of 6 months. The ammonium -N “stripped” manures were mixed with a loamy sand textured soil in pots 16.5 cm x 16.5 cm x 20 cm), and sown with perennial ryegrass (*Lolium perenne* L.). The treatments were arranged in a randomised block design with three replicates of each treatment.

The manures were analysed for dry matter, organic carbon (C), total N, ammonium-N and for poultry manures, uric acid-N. Target applications were 200 kg/ha total N with additional phosphorus, potassium and sulphur applied in solution to the pots to ensure that grass growth was not limited by an inadequate supply of major nutrients other than nitrogen. Six grass cuts were taken during the experiment, with the ryegrass N offtakes used as a measure of organic N mineralisation.

## **2.2. Field studies**

In June 1996, field experiments were established at 3 sites with contrasting soil types and climatic conditions (Table 1), to measure N mineralisation from the organic N fraction of 9 farm manures (2 cattle slurry cattle FYM and pig FYM, 1 pig slurry, layer manure and broiler litter) and six inorganic N treatments (0-150 kg/ha). There were 3 replicates of each treatment in a randomised block design.

At each site, ammonium-N “stripped” manures were applied to the plots (3 m x 10 m) prior to the establishment of perennial rye grass. The manures were left on the soil surface for 48 hours after application to encourage further ammonia volatilisation before incorporation. 1 m<sup>2</sup> mesh squares were placed randomly on each plot before application so that samples of the manures could be collected at the time of soil incorporation. The manure samples were analysed for dry matter, total C, total N, ammonium-N and for poultry manures uric acid-N, so that the amount of N applied to each treatment could be quantified (Table 2). At ADAS Rosemaund, extremely dry weather after the experiment was set up meant that the grass did not germinate. Grass was satisfactorily established on the plots in February 1997.



Site	Soil texture	Average annual rainfall (mm)	Topsoil total N (%)	Topsoil organic matter (%)
ADAS Gleadthorpe	Loamy sand	650	0.04	1.7
ADAS Rosemaund	Silty clay loam	800	0.20	2.9
IGER North Wyke	Sandy loam	1000	0.08	1.8

*Table 1.*  
*Soil type, cropping and average annual rainfall*

Between June 1996 and June 1997, 5 grass cuts were taken at Gleadthorpe and 4 at North Wyke. The late grass establishment at Rosemaund meant that only 1 cut was possible.

Treatment	Total N loading (kg/ha)		
	Gleadthorpe	North Wyke	Rosemaund
Cattle FYM 1	526	632	1366
Cattle FYM 2	901	848	824
Pig FYM 1	863	1031	816
Pig FYM 2	794	861	1024
Cattle slurry 1	172	364	231
Cattle slurry 2	676	724	569
Pig slurry	577	543	639
Layer manure	674	364	326
Broiler litter	659	638	444

*Table 2.*  
*N loadings at each field site following application of ammonium-N stripped manures*

Porous ceramic cups (Webster et al., 1993) were installed at 90 cm depth on each manure treatment (4 per plot) to measure nitrate leaching losses. Drainage estimates were made using the IRRIGUIDE meteorological model (Bailey and Spackmann, 1996) with leachate samples collected every 2 weeks or following 25 mm of drainage whichever occurred sooner, for nitrate-N analysis. Nitrate-N concentrations in porous cup samples were combined with drainage volume estimates between the sampling dates to measure nitrate-N leaching losses (Lord and Shepherd, 1993). Soil temperatures were measured daily and soil moisture contents monthly.

The sum of plant N uptakes and nitrate leaching measurements on the control was subtracted from those on the manure treated plots to quantify organic N mineralisation. The mineralisation measurements were corrected for the small amount of readily available N applied in the manures.

Dry matter yields on the manure treatments in year 1 were compared with the yields on the inorganic N treatments to calculate the fertiliser equivalent value of the mineralised organic N.

### 2.3. Modelling

Field assessments of manure organic N mineralisation at Gleadthorpe and North Wyke were compared with predictions from N-CYCLE (Scholefield et al., 1991), MANNER (Chambers et al., 1998) and other manure models; Beauchamp and Paul (1989), Bhat et al., (1989) and Diltz et al., (1990).

## 3. Results and discussion

### 3.1. Pot Incubation studies

Net N offtakes were greatest from a layer manure (115 kg/ha N) and a pig slurry (60 kg/ha N) and least from a dairy slurry (3 kg/ha N) and a beef FYM (13 kg/ha ). During the 60 days following incorporation of the manures, net immobilisation was measured on the dairy slurry and beef FYM treatments. By the fourth harvest (120 days), the mineralisation rates had decreased to low, relatively constant levels for all manure types.

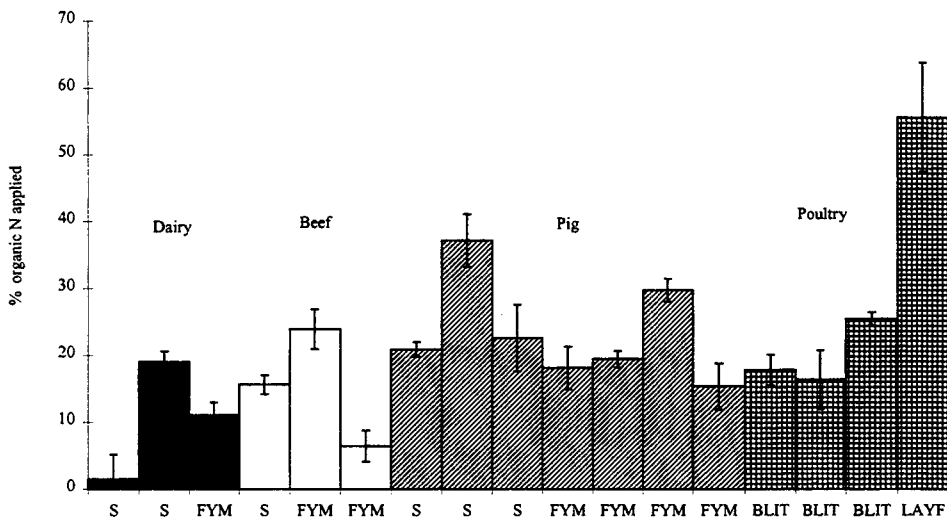

Notes S = slurry, FYM = farmyard manure, BLIT = broiler litter, LAY = layer manure

Figure 1  
Mineralised from different manure types.

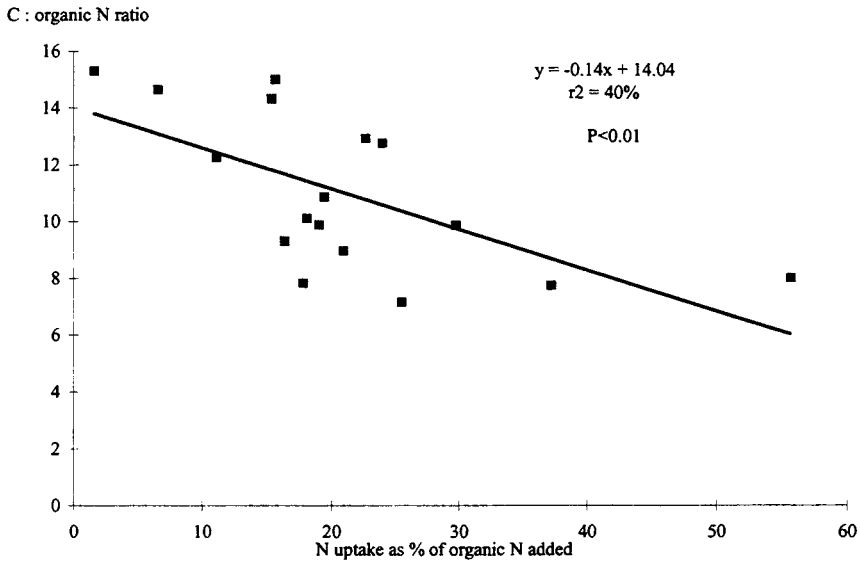

*Figure 2*  
 Relationship between %N mineralisation and C : organic N ratio.

The % organic N mineralised (Figure 1) was greatest from a layer manure (55%) and a pig slurry(37%) and least from a dairy slurry (2%) and a beef FYM (6%). The amount of organic N mineralised was inversely proportional to the C:organic N ratio of the manures ( $P < 0.01$ ,  $r^2 = 40\%$ ), - Figure 2.

### 3.2. Field studies

#### **N uptake**

At Gleadthorpe, uptakes of mineralised organic N were greatest on the pig slurry and layer manure treatments with 265 and 200 kg/ha N taken up respectively between June 1996 and June 1997, respectively. On the cattle FYM-2 and pig FYM-2 treatments, there was no net N mineralisation between the first and fourth sampling dates (8 months). Net N uptakes on these treatments were 30 and 23 kg/ha N, respectively.

At North Wyke grass N uptakes were generally greater than at Gleadthorpe for all the manure treatments which may reflect warmer soil temperatures in the autumn following application (Figure 3). Between June 1996 and June 1997, the greatest N uptakes were measured on the layer manure and pig FYM-1 treatments at ca. 339 and 323 kg/ha N, respectively. The lowest N uptakes at 36 kg/ha N was measured on the cattle slurry -1 treatment. N uptake on the other treatments ranged between 145 and 280 kg/ha N.

Cumulative day degrees above 5°C

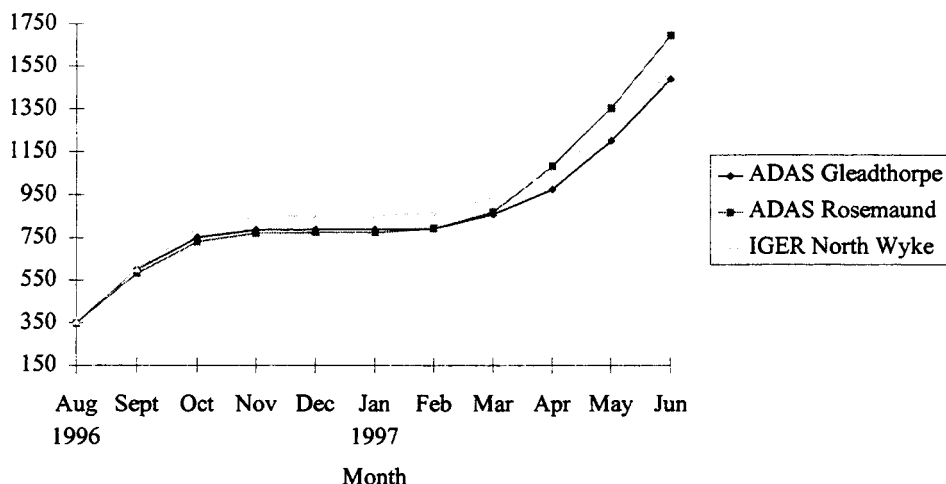

*Figure 3*  
Cumulative day degrees above 5°C at 10 cm soil depth.

At Rosemaund, N uptakes were lower than the other sites because of the late grass establishment. The greatest uptake was 140 kg/ha N measured on the pig slurry treatment and least 27 kg/ha on the cattle slurry - 2 treatment.

At all three sites net N mineralisation was continuing 18 months after the manures had been applied.

### **Nitrate leaching**

At Gleadthorpe and North Wyke, nitrate leaching losses from the cattle FYM, cattle slurry and pig FYM-2 treatments were similar at ca. 5 kg/ha N. Losses on the pig FYM-1, pig slurry and poultry manure treatments were ca. 10, 15 and 20 kg/ha N at Gleadthorpe, and 25, 50 and 10 kg/ha N at North Wyke, respectively. The failure to establish a grass cover at Rosemaund meant that there was no plant N uptake before drainage began over winter 1996/97 and as a consequence nitrate leaching losses were overall greater than at the other sites in the range 25-50 kg/ha N.

### **Mineralisation**

Generally, organic N mineralisation (sum of net plant uptake and net N leached) was greatest following the pig slurry and layer manure applications, with 52% and 36% of the applied organic N mineralised at Gleadthorpe, and 67% and 60% at North Wyke, respectively. At Rosemaund the greatest amount of mineralisation occurred on the cattle slurry-2 treatment (31%) followed by the pig slurry treatment (25%), Figure 4.

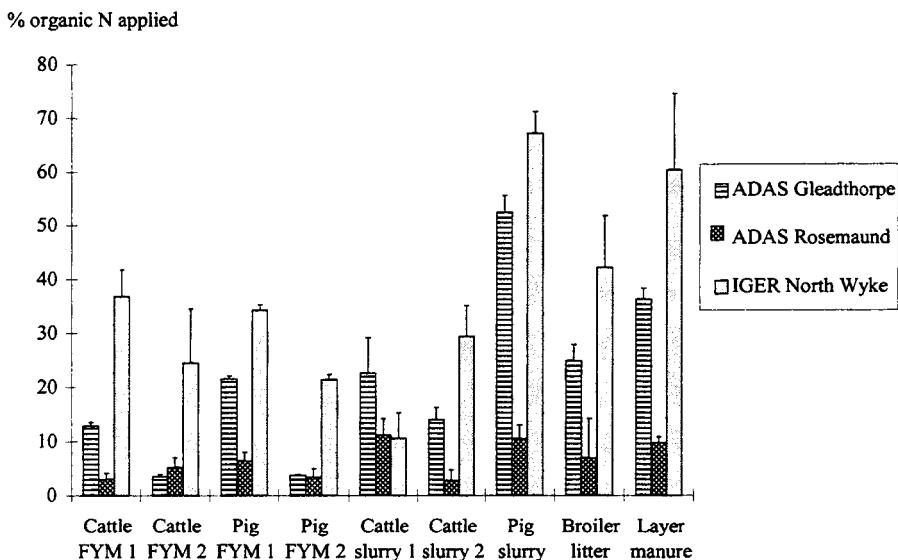

*Figure 4*  
*Net mineralisation between June 1996 to June 1997.*

The field mineralisation measurements were in general agreement with those obtained in the pot incubation study, although it was not possible to establish a relationship between the field N mineralisation measurements and C : organic N ratio of the applied manures.

In the first growing season following application (i.e. six months from June to December), grass dry matter yields on the cattle FYM - 1, cattle FYM -2 and cattle slurry - 2 treatments were equivalent to those from inorganic fertiliser N applications of 96, 101 and 117 kg/ha N at Gleadthorpe and 88, 102 and 84 kg/ha N at North Wyke, respectively. Dry matter yields on the pig FYM-2 treatment at Gleadthorpe, the pig FYM -1 and broiler litter treatments at North Wyke were equivalent to 121, 129 and 89 kg/ha fertiliser N applications, respectively. It was not possible to calculate fertiliser N equivalents for the other treatments because dry matter yields exceed those of the 150 kg/ha fertiliser N applications. At Rosemaund failure to establish a grass crop meant that it was not possible to determine fertiliser N equivalents in the first season following manure application.

### **Modelling**

The field measurements of N mineralisation at Gleadthorpe and IGER (June 1996 to June 1997) were compared with model predictions. Comparisons of the field measurements and model predictions for cattle FYM-1, layer manure and pig slurry treatments are shown in Figure 5 and Figure 6.

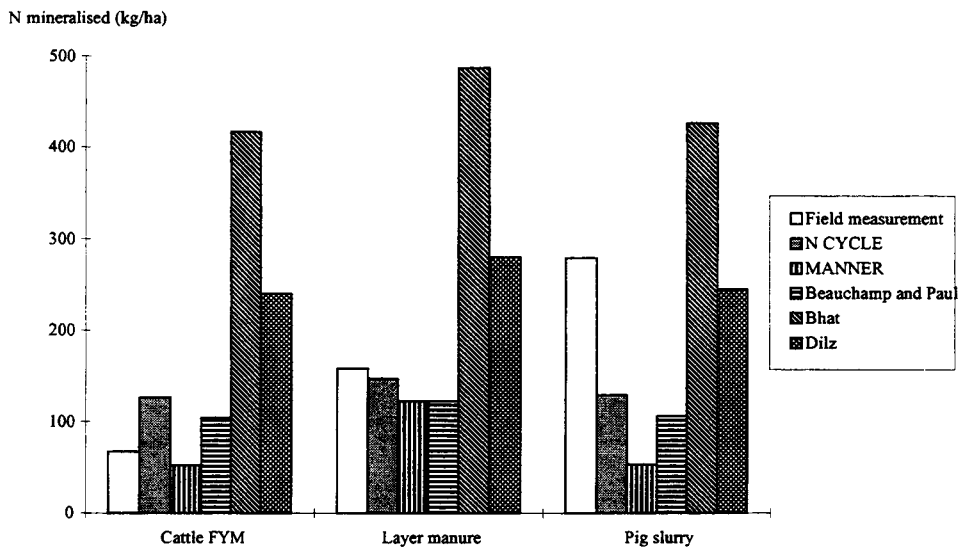

*Figure 5  
Predicted and measured N mineralisation, ADAS Gleadthorpe*

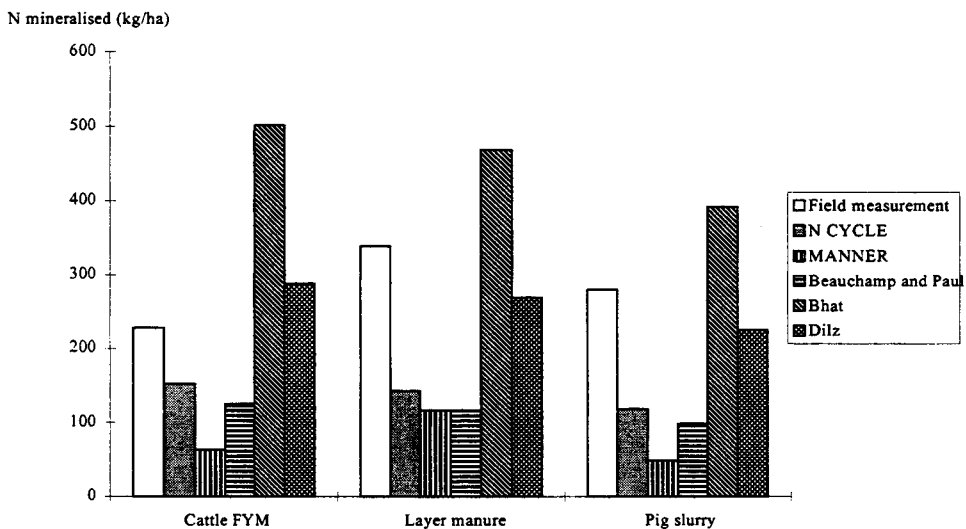

*Figure 6  
Predicted and measured N mineralisation, IGER North Wyke.*

In general, the best quantitative predictions were provided by N-CYCLE, MANNER and the Beauchamp and Paul (1989) model. This was because these models estimated that between 10 and 20% of the organic N was mineralised in a first growing season after application. The Bhat et al. (1989) and Diltz et al. (1990) models over estimated mineralisation under these conditions, because they assumed that 80% and 46% respectively of the organic N would mineralise. None of the models were able to predict mineralisation differences between the manure types.

## 5. Acknowledgement

Funding of this work by the UK Ministry of Agriculture Fisheries and Food (MAFF) is gratefully acknowledged.

## 6. References

**Bailey R.J. and Spackmann, (1996).** A model for estimating soil moisture changes as an aid to irrigation scheduling and crop water-use studies: I Operational details and description. *Soil Use and Management* 12 122-129.

**Beauchamp, E.G. and Paul, J.W., (1989).** A simple model to predict manure N availability to crops in the field. In: *Nitrogen in Organic Wastes Applied to Soils* (Eds: J.A. Hansen and H.Henriksen) pp 140-149. Academic Press London.

**Bhat, K.H.S., Flowers, T.H. and O'Callaghan, J.R. (1989).** A model for simulation of the fate of nitrogen in farm wastes on land application. In *Nitrogen Losses and Surface Runoff* (Ed:J.C. Brogan) pp 222 -250 Brussels.

**Chambers, B.J., Smith, K.A. and van der Weerden, T.J., (1997).** Ammonia emissions following the land spreading of solid manures. In : *Gaseous Nitrogen Emissions from Grassland* (Eds: S.C. Jarvis and B.F. Pain), pp 275-280. CAB International UK.

**Chambers, B.J., Lord, E.I., Nicholson, F.A. and Smith, K.A., (1998).** Predicting nitrogen availability and losses following land application of manures. In : *Proceedings of the International workshop on Environmentally Friendly Management of Animal Farm Waste.* (Ed. T. Matsunaka) Sapporo Japan pp 79-83.

**Diltz, K., Postmus, J. and Prins, W.H. (1990).** Residual effect of long-term applications of farmyard manure to silage maize. *Fertiliser Research* 26 249-252.

**Lord, E.I. and Shepherd, M.A., (1993).** Developments in the use of porous ceramic cups for measuring nitrate leaching. *Journal of Soil Science* 44 435-451.

**MAFF**, (1994) Fertiliser Recommendations for Agricultural and Horticultural Crops. Ministry of Agriculture Fisheries and Food. Reference Book 209 (sixth edition) HMSO, London.

**Jarvis, S.C. and Pain, B.F.** (1990). Ammonia volatilisation from agricultural land. The Fertiliser Society Proceedings No.298. Greenhill House, Thorpe Wood, Peterborough.

**Scholefield, D., Lockyer, D.R., Whitehead, D.C. and Tyson, K.C.** (1991). A model to predict transformation and losses of nitrogen in UK pasture grazed by beef cattle. *Plant and Soil*, 132 165-177.

**Unwin, R.J., Shepherd, M.A. and Smith, K.A.** (1991). Controls on manure and sludge applications to limit nitrate leaching. Does the evidence justify the restrictions which are being proposed? In : *Treatment and use of sewage sludge and liquid agricultural wastes* (ed. P.L'Hermite) pp 261-270 Elsevier Applied Science, London.

**Webster, C.P., Shepherd, M.A., Goulding, K.W.T. and Lord, E.I.** (1993). Comparison of methods for measuring the leaching of mineral nitrogen from arable land. *Journal of Soil Science* 44 46-62.





# Short term carbon and nitrogen transformations following pig and cattle slurry incorporation in soils

*Transformations azotées et carbonées à court terme consécutivement à l'incorporation de lisier bovin et porcin au sol.*

**T. Morvan, P. Leterme**

Unité d'agronomie, INRA, ENSAR,  
65, rue de Saint Briec, 35042 Rennes. France  
E-mail : morvan@rennes.inra.fr

## **Abstract.**

*Carbon mineralization and nitrogen biotransformations were studied in a laboratory experiment, for 24 days, at 16°C. Thirteen pig slurries and five cattle slurries were labelled with  $(^{15}\text{NH}_4)_2\text{SO}_4$  and added to a loamy soil ( $S_1$ , pH 5.4 organic matter 2%) and to two loamy sand soils ( $S_2$  et  $S_3$ , pH 6.7 and 5.5, organic matter 3.9%).*

*The rates of organic carbon mineralization of the slurries were high, and significantly higher in  $S_1$ , compared to  $S_2$  and  $S_3$  soils. Carbon mineralization was well described by a two-compartment model, the first compartment being the soluble fraction of organic matter determined by Van Soest's method, and the second corresponding to the non-soluble fraction. The high level of carbon decomposition strongly stimulated the immobilization of ammonium. Gross mineralization also varied greatly with soils and slurries. Net mineralization was observed for all treatments, on  $S_1$ , whereas net immobilization was observed in 28 % of cases, and concerned mainly treatments on  $S_3$ . Nitrification of the ammonium in slurries was complete on day 24 on  $S_2$  and  $S_3$ , but not on  $S_1$  soils ; rates of nitrification varied greatly between soils, during the active phase of nitrification following the latent period.*

*A simple model describing nitrogen and carbon fluxes was constructed from the relationships between the chemical and biochemical composition of the slurries, carbon and nitrogen mineralization and nitrogen immobilization.*

Key words : slurry,  $^{15}\text{N}$ , nitrogen biotransformations, carbon mineralization

## **Résumé**

La minéralisation apparente du carbone et les biotransformations des formes azotées du lisier ont été étudiées en laboratoire, sur une durée de 24 jours, à la température de 16°C. Treize lisiers de porc et cinq lisiers de bovin enrichis en azote 15 par addition de  $(^{15}\text{NH}_4)_2\text{SO}_4$  ont été apportés sur un sol limoneux ( $S_1$ , de pH 5,4

et de taux de matière organique 2%) et deux sols limono-sableux ( $S_2$  et  $S_3$ , ayant respectivement un pH de 6,7 et 5,5 et de taux de matière organique égaux 3,9%).

Le taux de minéralisation du carbone organique des lisiers est significativement supérieur sur  $S_1$ , comparativement à  $S_2$  et  $S_3$ . La minéralisation du carbone en fin d'expérience est bien décrite par un modèle comprenant deux compartiments correspondant à : i) la fraction soluble déterminée par la méthode Van Soest, et ii) la fraction insoluble. L'importante activité de décomposition du carbone organique stimule fortement l'immobilisation de l'azote ammoniacal, qui représente 20 à 70% de l'azote ammoniacal apporté, le jour 24.

La minéralisation brute du système sol-lisier varie fortement selon les sols et les lisiers. On mesure un flux de minéralisation nette pour tous les traitements, sur  $S_1$  ; on observe par contre une organisation nette de l'azote dans 30% des cas, sur les sols 2 et 3.

La nitrification de l'ammonium des lisiers est achevée le jour 24, sur  $S_2$  et  $S_3$ , mais pas sur  $S_1$  ; les vitesses de nitrification varient considérablement selon les sols, au cours de la phase active succédant à la phase de latence.

Les relations établies entre la composition chimique et biochimique des lisiers, la minéralisation du carbone et de l'azote et l'immobilisation de l'azote permettent de proposer une modélisation simple des flux d'azote et de carbone, à la fin de la nitrification de l'ammonium du lisier.

Mots-clés : lisier,  $^{15}\text{N}$ , biotransformations de l'azote, minéralisation du carbone.

## 1. Introduction

Nitrate availability after slurry landspreading is determined by : i) the amounts of ammonia and organic nitrogen supplied, and ii) the rates of gaseous losses, rates of nitrification/immobilization of ammonia, and mineralization of the slurry organic nitrogen. Morvan et al (1996, 1997) showed in field experiments that gross immobilization / mineralization processes were high and mainly occurred during the first few days following the slurry spreading and that nitrification also occurred rapidly, but after a lag period.

Nitrogen transformations after addition of crop residues to soils have been investigated in many studies. Immobilization and mineralization appear to be linked to carbon decomposition, and mainly depend on : i) chemical and biochemical composition of the fresh organic matter (Azam et al, 1985, Mary et al, 1996), ii) the availability of inorganic nitrogen during C decomposition (Recous et al, 1995), iii) the accessibility of organic matter to the microbial biomass (Darwis, 1993, Angers et al 1997), and iv) soil characteristics (Nicolardot et al, 1986, Sparling et al, 1996).

The composition of slurries differ markedly from those of crop residues ; it can be presumed that the rates of C and N transformations may differ significantly from those observed with crop residues. Kirchmann and Lundvall (1993), for example, observed a different pattern of inorganic nitrogen evolution after addition of slurries to a soil than that usually measured after crop residues incorporation (Mary et al, 1996).

Pig and cattle slurry composition is characterized by great variability, due to : i) animal species, age and feed supply, and ii) aerobic or anaerobic transformations of the organic matter during storage (Van Faassen and Van Dijk, 1987). In fact, Kirchmann and Lunvall (1993) showed that the rates of nitrogen transformations differed significantly both between pig and cattle slurries, and between fresh or digested pig slurries.

Since there is little published information about the effect of slurry composition upon carbon and nitrogen transformations after the addition of slurry to soils, the purpose of our experiment was to study this effect, on a time scale corresponding to the duration of nitrification of the ammonia fraction of the slurry.

It is also becoming increasingly necessary to design and validate simple operational dynamic models, for prediction of the amount and rates of « production » of the nitrate available after slurry spreading. Such simple models could be useful for « tactical » decision support systems, and enable the decision makers to optimize the agronomic utilization of slurries, to calculate the risk of pollution. We propose therefore a simple model describing short term C and N biotransformations.

## **2. Material and methods**

### **2.1. Slurry composition and soil characteristics**

Thirteen pig and five cattle slurries were sampled in farms around Rennes, in Brittany. pH, dry matter content, ammonia ( $\text{N-NH}_4^+$ ) and total nitrogen ( $\text{N}_{\text{tot}}$ ), total inorganic (TIC) and organic (TOC) carbon contents were determined. These parameters were characterized by a considerable variability (table 1), in agreement with the results of Sommer and Husted (1995). The C:N ratios of the organic fraction were rather low, and ranged from 8.2 to 27 ; the neutral detergent soluble fraction, obtained by Van Soest's method (Linères and Djakovitch, 1993), trended to be higher than the soluble fraction of crop residues.

	minimum	maximum	median	mean
pH	6.8	8.8	7.6	7.6
dry matter (%)	1.9	19.2	1.4	1.8
N-NH <sub>4</sub> (g l <sup>-1</sup> )	0.26	5.34	3.1	3.2
N <sub>tot</sub> (g l <sup>-1</sup> )	0.87	9.60	6.1	5.7
TIC (g l <sup>-1</sup> )	0.02	2.27	0.91	0.85
TOC (g l <sup>-1</sup> )	13.30	81.30	34.5	38.5
TOC:N <sub>tot</sub>	3.7	17.2	8.0	7.9
TOC : N <sub>org</sub>	8.2	27.2	16.2	16.2
SOL (% TOC)	38	85	50.3	52.0

*Table 1.*  
Statistical parameters calculated from chemical and biochemical analyses of the eighteen slurries

The characteristics of the three soils are given in table 2.

	Soil 1	Soil 2	Soil 3
Clay	14.3	19.3	18.5
Silt	72.7	48.8	44.6
Sand	13.0	31.9	36.9
pH (water)	5.4	6.7	5.5
N org (%)	0.120	0.200	0.210
C org	1.14	2.29	2.27
OM (%)	2.0	3.94	3.90

*Table 2.*  
Selected physico-chemical characteristics of the three soils

## 2.2. Incubation procedure

The experiment was conducted at an average temperature of 16°C for 24 days. Soil samples of 500 g dry weight basis were placed in 2000 ml wide-mouth glass jars. The ammonium fractions of the slurries were enriched with <sup>15</sup>N, using a solution of ((<sup>15</sup>NH<sub>4</sub>)<sub>2</sub>SO<sub>4</sub>) 10% atom excess, which was thoroughly mixed with the slurry. The amount of slurry added to the soils were calculated to ensure rates of nitrogen supply in the soil, comparable with those usually measured in the field, after slurry spreading. The amounts of ammonia nitrogen added varied from 85 to 95 ppm for the pig slurries, and from 43 to 63 ppm for the cattle slurries. The soil water content was adjusted to 199 mg g<sup>-1</sup> soil, and remained constant until the end of the experiment. Each treatment was replicated twice.

CO<sub>2</sub> evolved was captured in traps containing 15 ml 1M NaOH. The sampling times were 1,3,8, 14 et 24 days for CO<sub>2</sub>. The sampling dates were 3, 8 and 24 days for the inorganic N analysis and were 8 and 24 days for the <sup>15</sup>N analysis.

### **2.3. Analytical procedures**

The carbonates trapped in the NaOH were precipitated with excess  $\text{BaCl}_2$  ; the remaining NaOH was assayed by 0.1 N HCl titration using phenolphthalein as indicator.

The same analytical procedures were used for  $^{14}\text{N}$  and  $^{15}\text{N}$  analysis as in Morvan et al (1997).

#### ***Flux calculations***

Gross N rates were calculated using the FLUAZ model described in detail by Mary et al (1998). FLUAZ combines a numerical model for solving the balance mass equations and a non linear fitting program for optimizing the N rate parameters. A single labelled treatment ( $\text{NH}_4^+$  labelled in our case) was used to calculate the rates of ammonium and nitrate immobilization ( $i_a$  and  $i_n$  respectively), mineralization ( $m$ ), nitrification ( $n$ ) and volatilization ( $v$ ). FLUAZ use was limited to treatments that presented a consistent  $^{15}\text{N}$  balance on days 8 and 24 ; gross nitrogen rates were calculated for 14, 8 and 11 treatments, on soils 1, 2 and 3 respectively.

The apparent C mineralization rate of the slurry was calculated assuming that the priming effect was negligible, and that the TIC supplied by the slurries was volatilized and trapped during the first day.

## **3. Results and discussion**

### **3.1. Carbon mineralization of the organic fractions of the slurries**

Carbon mineralization rates were high during the first five days after the start of the experiment, and remained significant until day 24 (fig 1). The cumulative amounts of C mineralized varied widely between the slurries, ranging from 17 to 43 % of the added C. Carbon mineralization rates measured in soils 2 and 3 were very similar, and significantly lower than the C- $\text{CO}_2$  evolved on soil 1.

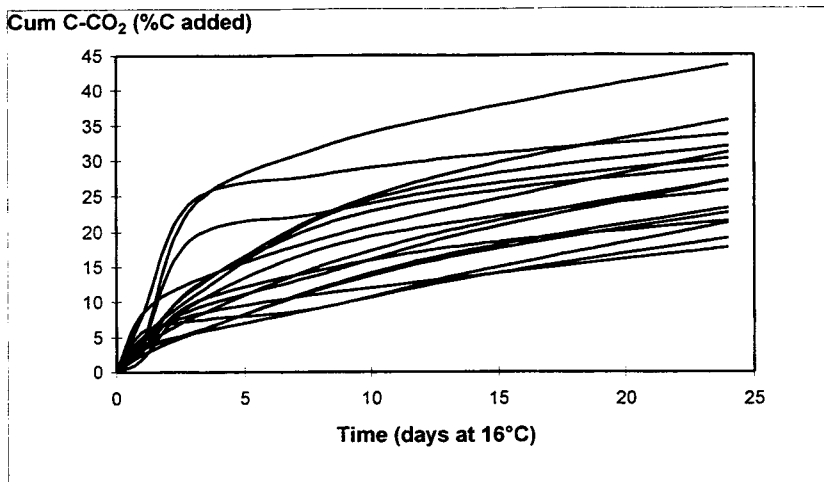

*Figure 1*  
 Mineralization kinetics observed on soil 1 for the 18 slurries  
 (similar patterns were observed for soils 2 and 3).

The cattle slurries were characterized by a lower rate of mineralization, in agreement with the results of Kirchmann and Lundvall (1993). The kinetics also differed considerably between slurries, the relative differences being higher during the first few days, compared to those on day 24.

Kirchman and Lundvall (1993) obtained similar kinetics and rates of C-CO<sub>2</sub> evolution, after the addition of fresh and digested slurries to a soil. These authors found that carbon mineralization rates ranged from 20 to 43 %, at 25 °C, twelve days after slurry incorporation (comparable with our results, on day 24, if a Q<sub>10</sub> of 2 for carbon transformations is considered for the 15-25 °C temperature range). The rate of evolution of C-CO<sub>2</sub> was also similar to the rates of C mineralization of plant residues, such as wheat straw (Mary et al, 1996) or maize roots (Azam et al, 1985), when decomposition was not limited by the soil inorganic N content (Recous et al, 1995).

The initial high rates of C mineralization have been attributed to the rapid decomposition of the easily decomposable components of applied organic matter of low molecular weight ; Reinertsen et al (1984) postulated that fresh organic matter decomposition in the early stages was largely dependent on the sizes of the water soluble C pool, and of an intermediately available C pool. Our results are in good agreement with this hypothesis : we found that carbon mineralization rates were closely correlated to the neutral detergent soluble fraction, over the first few days (similar correlation coefficients for all three soils, and equal to 0.95, 0.94 and 0.91 on days 3, 8 and 14 respectively).

### 3.2. Gross and net fluxes of nitrogen immobilization and mineralization

The gross mineralization (m) and immobilization (i) fluxes varied widely between slurries (fig 2) and were mainly apparent during the first eight days, the 0-8 days mineralization accounting on average for 78 % of the total nitrogen mineralization.

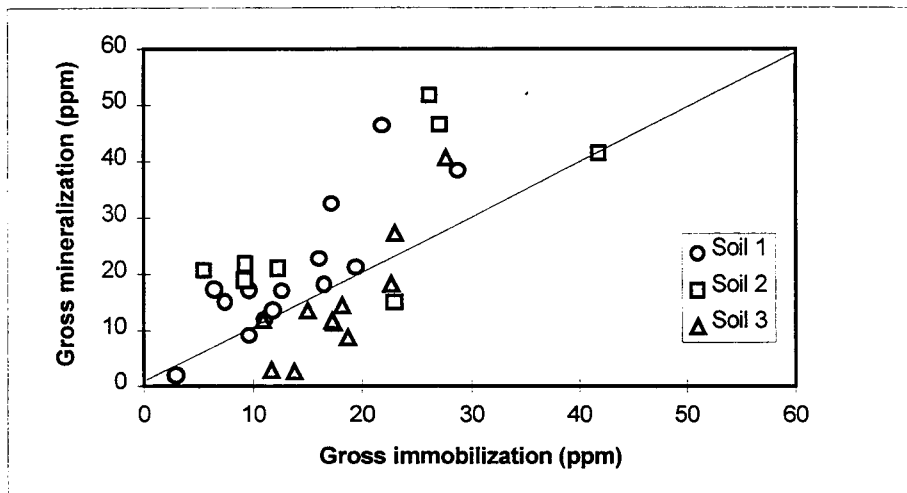

Figure 2  
Comparison of gross nitrogen immobilization and mineralization (ppm)  
of slurries, calculated on day 24.

The gross processes depended on soil type, gross immobilization being lower on soil 1, than on soils 2 and 3, whereas nitrogen mineralization on soil 1 tended to be intermediate between the higher fluxes measured on soil 2 and the lower ones measured on soil 3.

Net fluxes were obtained from the difference (m-i), and varied from -11 to +29 ppm on day 24 ; net mineralization was dominant, and observed for all treatments, on soil 1. Despite the low C:N ratios of the organic fractions of the slurries, net immobilization was observed in 29 % of the cases, and mainly on soil 3. These contrasting results are consistent with those of Kirchmann and Lundvall (1993) , who did not find any net mineralization after the incubation of cattle and anaerobic pig slurry, in contrast to that of fresh and anaerobically digested pig slurry. These authors also pointed out that the net immobilization occurring during the early stages was significantly correlated to the concentrations of fatty acids, which could represent 10 to 30 % of the total C, and act as very rapidly decomposable C sources.



### 3.3. C-N relationships

- Gross immobilization ( $i$ ) has been related to carbon mineralization in the following expression (Recous et al, 1995) :

$$i = \frac{Y}{r_{bio} \cdot (1 - Y)} \cdot C_{min} = R \cdot C_{min}$$

where  $r_{bio}$  is the C:N ratio of the newly-formed microbial biomass,  $Y$  the C assimilation yield, and  $C_{min}$  the amounts of C mineralized. The 'R' ratio values were calculated for each soil (table 3), assuming that these remained constant over the short duration of the experiment.

	R	Interval confidence 95% level	R <sup>2</sup>
Soil 1	0.076	0.070 - 0.082	0.78
Soil 2	0.089	0.080 - 0.098	0.85
Soil 3	0.107	0.101 - 0.114	0.88

Table 3.

*Values of R, given by the relationship :  $i = R \cdot C_{min}$ , confidence interval at the 95% level, and value of the determination coefficient.*

The results are consistent with the values calculated by Aita (1996) and Darwis (1993), during wheat straw decomposition, which ranged from 0.080 to 0.125. The significantly different values of R indicate variable values of  $r_{bio}$  or  $Y$ , or both parameters, between the soils. Assuming that the  $r_{bio}$  value was the same for each soil, and supposed equal to a usual value of 10, the R values could be used to calculate Y values of 0.44, 0.47 and 0.52 on soils 1, 2 and 3 respectively.

### 3.4. Nitrification

The few sampling dates didn't permit a fine description of the typical pattern of nitrification kinetics, usually Follow Mickaelis Menten kinetics (Le Pham et al, 1984). We did however observe that the lag period was nearly three days on soils 1 and 3, but shorter on soil 2. This was followed by an active nitrification phase (fig 3). Ammonium depletion was complete by day 24 on soils 2 and 3, whereas significant amounts of  $N-NH_4$  (2-32 ppm) still remained on soil 1. Apparent rates of nitrification over the 3-8 days period varied greatly between soils, ranging from 6.0 to 9.1 mg N  $kg^{-1}$  soil on soil 2, and from 2.4 to 3.3, and from 3.2 to 4.2 mg N  $kg^{-1}$  soil on soils 1 and 3.

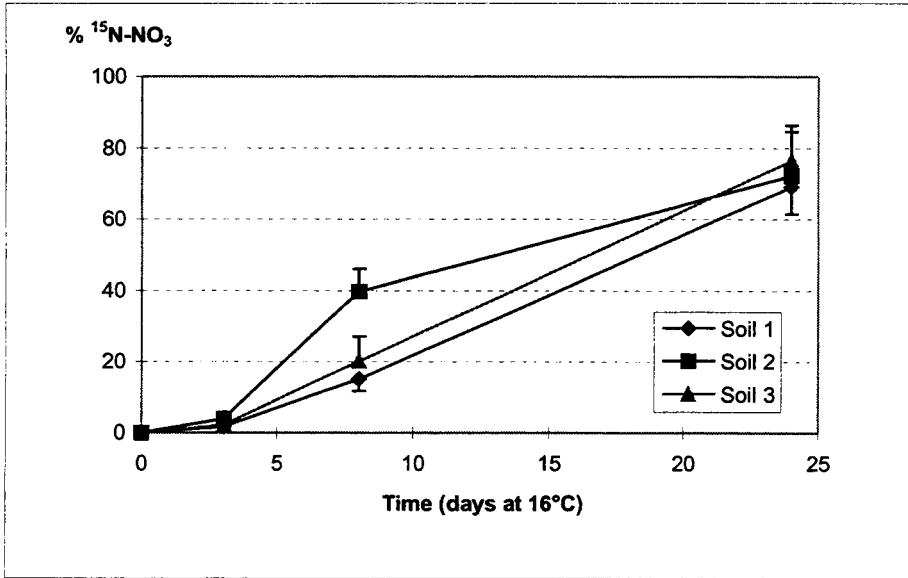

*Figure 3.*  
*Plot of the mean percentage of <sup>15</sup>N-NO<sub>3</sub> for each soil (vertical bars indicate the standard deviation calculated after pooling the treatments, for each soil)*

### 3.5. A simple model of slurry C and N transformations

Previous results were used to make certain assumptions and calibrate a simple dynamic model describing C and N transformations following slurry addition to soils during the period of slurry ammonium nitrification (fig 4). Microbial growth, maintenance and death was not considered in this simplified approach, implying that remineralization and recycling were neglected. Direct assimilation of organic nitrogen compounds by the microbial biomass was also neglected. Given these limitations, the gross immobilization and mineralization could be linked to carbon mineralization by means of simple stoichiometric relationships (table 4).

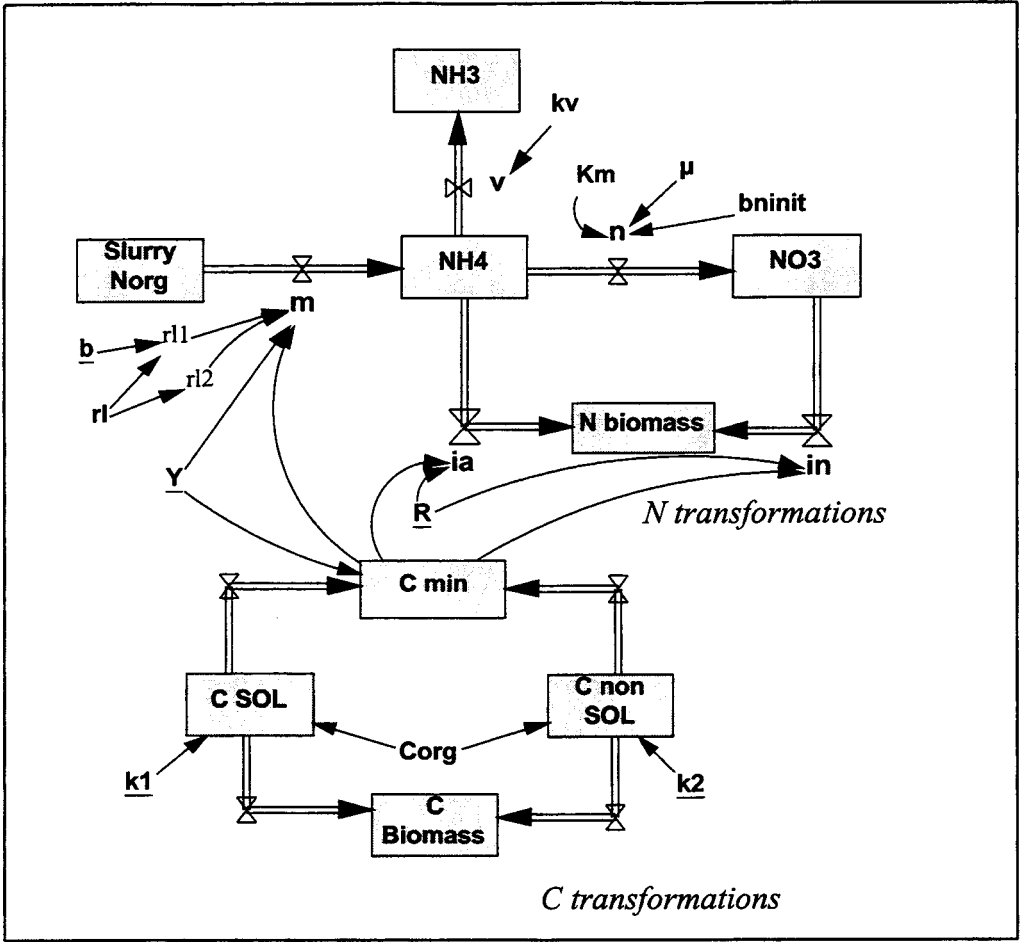

Figure 4.  
Flow chart of C and N slurry transformations after addition of slurry to soils  
(input parameters obtained by numerical fitting are underlined)

Total organic C supplied	$C_{org}$	$\mu\text{g g}^{-1}$ soil	input
C soluble fraction	SOL	dimensionless	input
Slurry organic N applied	$N_{org}$	$\mu\text{g g}^{-1}$ soil	input
Ammonia supplied	$NH_4$	$\mu\text{g g}^{-1}$ soil	input
$C_{org}:N_{org}$ ratio	$rl$	dimensionless	input
C:N ratio of the soluble fraction	$rl_1$	dimensionless	$rl_1 = b \cdot rl$
C:N ratio of the non soluble fraction	$rl_2$	dimensionless	$rl_2 = f(C_{org}, SOL, rl, rl_1)$
C assimilation yield	$Y$	dimensionless	constant / soil
$i : C_{min}$ ratio	$R$	$\mu\text{g N } \mu\text{g}^{-1}$ C	constant / soil
decay constant rate for volatilization	$k_v$	$\text{day}^{-1}$	input
decay constant rate for SOL C pool	$k_1$	$\text{day}^{-1}$	constant / soil and slurry type
decay constant rate for non SOL C pool	$k_2$	$\text{day}^{-1}$	constant / soil and slurry type
specific growth rate of nitrifiers	$\mu$	$\text{day}^{-1}$	constant / soil
$rl_1:rl$ ratio	$b$	dimensionless	constant
Initial nitrifying biomass	$bn_{init}$	cells $\mu\text{g}^{-1}$ soil	constant / soil
Mickaelis constant	$K_m$	$\mu\text{g g}^{-1}$ soil	constant

*Table 4.*  
*Input parameters and relationships used in the model*

---

### **Relationships**

---

$$C_{min} = (1 - Y) \cdot [SOL \cdot C_{org} \cdot (1 - e^{-k_1 t}) + (1 - SOL) \cdot C_{org} \cdot (1 - e^{-k_2 t})]$$

$$i = i_a + i_n = R \cdot C_{min}$$

$$m = \frac{1}{rl_1} \cdot SOL \cdot C_{org} \cdot (1 - e^{-k_1 t}) + \frac{1}{rl_2} \cdot (1 - SOL) \cdot C_{org} \cdot (1 - e^{-k_2 t})$$

$$n = \int_0^t \mu \cdot bn \cdot \frac{[NH_4]}{K_m + [NH_4]}$$

$$v = \int_0^t kv \cdot [NH_4]$$

---

The following assumptions were made :

- the rate of decomposition of the slurry carbon could be described by a two-compartment model, as suggested by the great variability of carbon mineralization kinetics and rates. The easily decomposable compartment was assumed to be the neutral detergent soluble fraction (SOL), the second pool consisting of the non-soluble fraction,
- the C:N ratio of the SOL fraction ( $r_{r1}$ ) was assumed to be linked to the global C:N ratio of the total organic fraction of the slurry ( $r_l = b.r_l$ )
- the C:N microbial ratio ( $r_{bio}$ ) and the assimilation yield of the microbial biomass ( $Y$ ) were presumed to remain constant throughout the experiment.

Nitrification rate was modeled by Mickaelis Menten kinetics ; the effect of pH on the rate of nitrification was not considered.

The model requires few parameters : i) the amounts of soluble and total organic carbon supplied by the slurry, ii) the amounts of ammonia and organic nitrogen, and iii) the rate of volatilization. The other input parameters are constants, such as the  $b$  parameter, or depend only on soil type ( $Y, R, \mu, bn_{init}$ ), or on the soil and slurry type (pig or cattle slurry) ( $k_1, k_2$ ). Such parameters were obtained by numerical optimization procedures carried out on the data used for the FLUAZ calculations. The required input parameters are given in table 4.

The main results were that :

- the great variability in the kinetics and final rates of C mineralization observed between slurries could be well described by a two-compartment model ( $R^2 = 0.97$  between predicted and measured values). Accurate prediction of C mineralization was obtained by using the **same  $k_1$  and  $k_2$**  decay constants values for all pig slurries, and the **same  $k_1$  and  $k_2$**  values which differed from those of the pig slurries, for cattle slurries. This is of great interest for the purpose of an operational model,
- the C-N relationships provided reasonable predicted values for  $i$  and  $m$ , on days 8 and 24, if the the ratio  $r_{l1}:r_l$  was equal to 1.23,
- the adjusted values of apparent assimilation yield ranged from 0.52 to 0.61 for the different soils ; they were in good agreement with the values given by many authors, and explained the differences due to the soil, for  $i$  and  $m$ ,
- this simple model was able to provide an accurate prediction of the amounts of nitrate available during nitrification of the ammonia of the slurry, and reasonable prediction at the end of nitrification (fig 5).

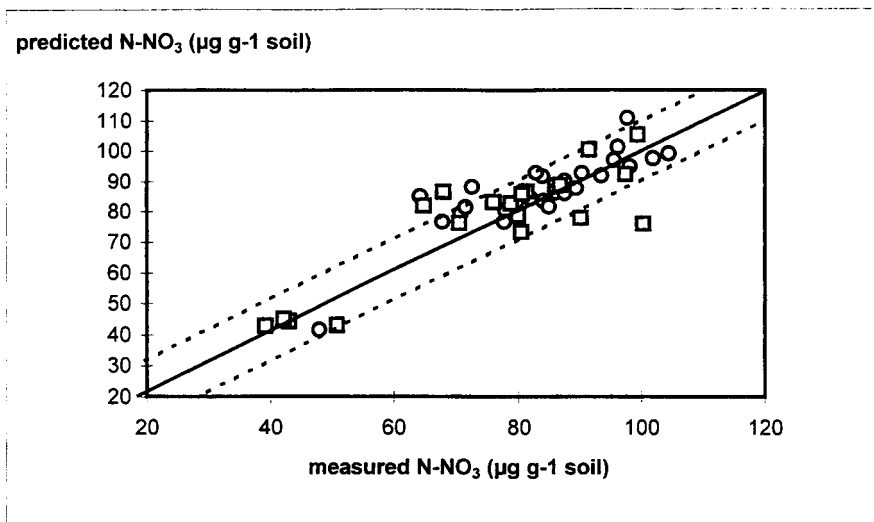

*Figure 5.*

*Comparison of measured and predicted amounts of nitrate ( $\mu\text{g g}^{-1}$  soil), on day 24. (blue rounded points were obtained with treatments used to fit the model parameters; green squared points were obtained with independent datas)*

#### **4. Conclusion**

We have shown that the great variability observed between the carbon and nitrogen biotransformations of different slurries can be related to the chemical and biochemical composition of these latter.

A simple dynamic model, requiring few parameters, was calibrated on three soils and gave an accurate description of the short term nitrogen transformations. The discrepancies between measured and predicted gross N fluxes might be explained by the fact that remineralization was not taken into account. Further investigations will need to be made : i) to quantify the turnover and recycling of the microbial biomass, and ii) to model the effects of the soil characteristics.

## - 5. References

**Aita C**, 1996. Couplage des cycles du carbone et de l'azote dans les sols cultivés : Etude au champ des processus de décomposition après apport de matière organique fraîche. Thesis Université Pierre et Marie Curie, Paris 6. 209 p.

**Angers DA, Recous S**, 1997. Decomposition of wheat straw and rye residues as affected by particle size. *Plant and Soil*, 189, 197-203.

**Azam F, Haider K, Malik KA**, 1985. Transformation of  $^{14}\text{C}$  labelled plant components in soil in relation to immobilization and remineralization of  $^{15}\text{N}$  fertilizer. *Plant and Soil* 86, 15-25.

**Darwis S**, 1993. Effet des modalités de gestion de la paille de blé sur l'évolution du carbone et de l'azote au cours de sa décomposition dans le sol. Thesis INA Paris-Grignon, 165 p.

**Kirchmann H, Lundvall A**, 1993. Relationship between N immobilization and volatile fatty acids in soil after application of pig and cattle slurry. *Biol Fertil Soils* 15, 161-164

**Le Pham M, Lambert R, Laudelout H**, 1984. Estimation de la valeur fertilisante azotée du lisier par simulation numérique. *agronomie*, 4, 63-74.

**Linères M, Djakovitch JL**, 1992. Caractérisation de la stabilité biologique des apports biologiques par l'analyse biochimique. In : *Matières organiques et agricultures. Actes des 4èmes journées du GEMAS et du 5ème forum du COMIFER*. Blois, France. Decroux, Ignazi Eds, 93-102.

**Mary B, Recous S, Darwis D, Robin D**, 1996. Interactions between decomposition of plant residues and nitrogen cycling in soil. *Plant and Soil*, 181, 71-82.

**Mary B, Recous S, Robin D**, 1998. A model for calculating nitrogen fluxes in soil using  $^{15}\text{N}$  tracing. *Soil Biol Biochem*, (in press).

**Morvan T, Leterme P, Mary B**, 1996. Quantification des flux d'azote consécutifs à un épandage de lisier de porc sur triticales en automne par marquage isotopique  $^{15}\text{N}$ . *agronomie*, 16, 541-552.

**Morvan T, Leterme P, Arsene G G, Mary B**, 1997. Nitrogen transformations after the spreading of pig slurry on bare soil and ryegrass using  $^{15}\text{N}$ -labelled ammonium. *European Journal of Agronomy*, 7, 181-188.

**Nicolardot B, Guiraud G, Chaussod R, Catroux G**, 1986. Minéralisation dans le sol de matériaux microbiens marqués au carbone 14 et à l'azote 15 : quantification de l'azote de la biomasse microbienne. *Soil Biol Biochem*, 3, 263-273.

**Recous S, Robin D, Darwis S**, 1995. Soil inorganic N availability : effect on maize residue decomposition. *Soil Biol Biochem*, 12, 1529-1538.

**Reinertsen S A, Elliott L F, Cochran V L, Campbell G S**, 1984. Role of available carbon and nitrogen in determining the rate of wheat straw decomposition. *Soil Biol Biochem.*, 5, 459-464.

**Sommer S G, Husted S**, 1995. The chemical buffer system in raw and digested animal slurry. *Journal of Agricultural Science, Cambridge*, 124, 45-53.

**Sparling G P, Chunya Zhu, Fillery I R P**, 1996. Microbial immobilization of <sup>15</sup>N from legume residues in soils of differing textures : measurement by persulphate oxidation and ammonia diffusion methods. *Soil Biol Biochem*, 12, 1707-1715.

**Van Faassen HG, Van Dijk H**, 1987. Manure as a source of nitrogen and phosphorus in soils. In : *Animal Manure on Grassland and Fodder Crops. Fertilizer or Waste ?* (Van der Meer HG, Unwin Rj, Vand Dijk TA and Ennik GC ed). Martinus Nijhoff Publishers. 27-46.



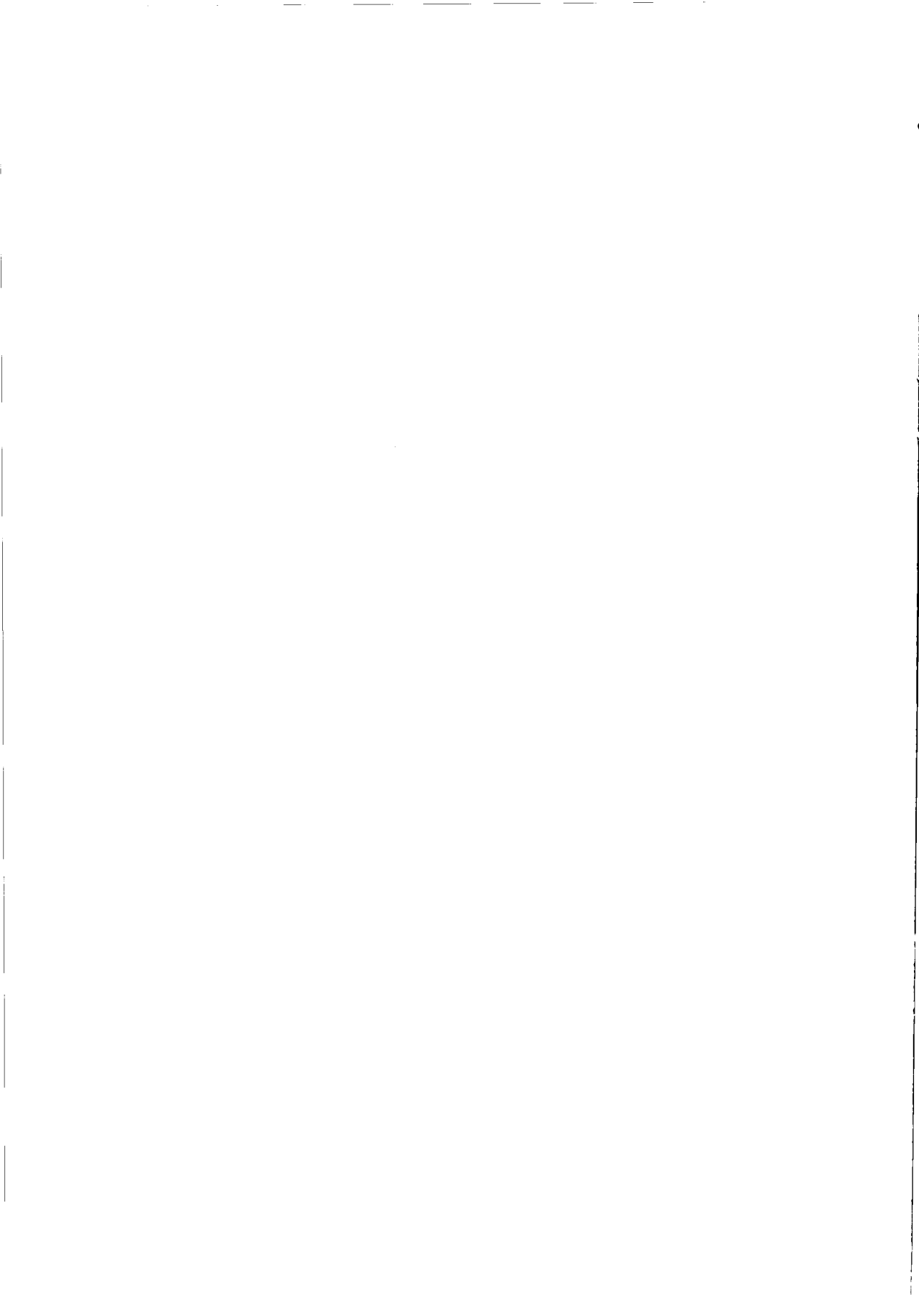

## Nitrogen efficiency of solid animal manures

### *Efficacité azotée des déjections animales solides*

#### **F. Lorenz, G. Steffens**

Institute for Agricultural Analysis and Research

Agricultural Chamber of Weser-Ems,  
PO Box 2549, D-26015 Oldenburg.

Germany

E-mail : lorenz.lufa.lwk-we@t-online.de

#### **C. Kalzendorf**

Institute for Crop Production and Crop Protection

Agricultural Chamber of Weser-Ems,  
PO Box 2549, D-26015 Oldenburg.

Germany

### **Abstract**

*An enormous increase of poultry meat production in the last decade increased the amounts of solid animal manure for use as a fertiliser in arable farming, but only poor knowledge about the N utilisation from these manures was available. Field experiments were carried out on three soil types to assess yield and nitrogen efficiency of broiler manure, turkey manure, layer dry manure and, as a well-known reference, cattle farmyard manure (FYM). Timing of application (autumn/spring) as well as manure rate and additional fertiliser N were varied. Soil mineral nitrogen at the end of the growing season was investigated to assess the potential for nitrate leaching. The cumulative results of the first five-year-period are reported here, and the following results were obtained :*

- *Spring application was usually superior to autumn application.*
- *Nitrogen efficiency of solid animal manures increased with decreasing C/N ratio. Mineral fertiliser N equivalents for spring application were 12 kg (cattle FYM), 25 kg (turkey litter), 31 kg (broiler litter), and 49 kg (layer dry manure). Optimal grain yields were only obtained with additional fertiliser N.*
- *Soil mineral nitrogen after harvest was within the range of good agricultural practice.*
- *From year to year subsequently increasing soil mineral nitrogen after harvest indicates a residual effect. Because of annual variation in growing conditions and thus a varying nitrogen demand, further research is required to evaluate the residual effects with regard to the development of the nitrogen requirement for optimal yields.*

### **Résumé**

L'augmentation considérable de la production avicole au cours des dix dernières années s'accompagne d'une augmentation des quantités de fumier utilisées comme fertilisants sur les terres cultivées.

Des essais au champ réalisés sur trois types de sol nous ont amené à préciser le rendement obtenu et l'efficacité de l'azote apporté suite à l'épandage de fumier de volailles de chair, de fumier de dindes et de fumier de poudeuses sec, ainsi qu'un fumier bovin de référence.

Les dates d'apports (automne, printemps) ainsi que la dose apportée et les engrais chimiques complémentaires ont été modulés.

L'azote minéral du sol à la fin de la période de culture a été mesuré afin d'évaluer le potentiel de lixiviation. Les résultats cumulés des cinq premières années de ce travail sont décrits dans cet article. Les principales conclusions sont les suivantes :

- Les apports de fumier au printemps sont plus efficaces que les apports d'automne.
- L'efficacité azotée des fumiers augmente lorsque le ratio C/N diminue. L'équivalent azote minéral pour les apports de printemps s'établit à 12 kg (fumier bovins), 25 kg (fumier dindes), 31 kg (fumier de volailles de chair) et 49 kg (fumier poudeuses sec). Les rendements optimums n'ont été obtenus qu'avec un complément d'engrais chimieue.
- L'azote minéral dans le sol à la récolte correspond à celui attendu par l'application de bonnes pratiques agricoles.
- L'effet résiduel de l'azote laissé dans le sol doit être mieux étudié.

## 1. Introduction

Heavily increasing poultry meat production (broilers and turkeys) during the last decade and the switch-over of nearly all layer farms from the slurry system to dry manure led to a strong increase in the amounts of solid manures produced by these animals. The manures are characterised by high dry matter contents and, hence, high concentrations of N, P and K which are often underestimated by farmers. Poor utilisation of nutrients and the risk of nitrate leaching may thus follow wrong application. This paper outlines ways to improve solid manure management and tries to find answers to the following questions :

1. When should solid animal manures be applied?
2. How is the nitrogen efficiency of solid animal manures?
3. Can optimal yields be obtained with solid animal manure alone, or is it necessary to add fertiliser N?
4. What is the effect of solid animal manures on soil mineral nitrogen after harvest?

## 2. Experimental details

Three static field experiments were established in 1993 in the Weser-Ems area, situated in the Northwest of Germany (average temperature of the year: 8.8 °C; average annual precipitation rate: 770 mm). Cropping was winter cereals (four years) and potatoes (one year, 1995). The experimental design was the following (table 1) :

Factor	Treatment
Soil type	1. organic sandy soil 2. sandy soil 3. loamy soil
Manure type	4. cattle FYM 5. turkey litter 6. broiler litter 7. layer dry manure
Application time	8. autumn 9. spring
Application rate	10. ~ 100 kg/ha total manure N 11. ~ 200 kg/ha total manure N (only spring)
Fertiliser N	12. without 13. 40 - 60 kg/ha N 14. 80 - 120 kg/ha N

*Table 1.  
Experimental design.*

All manures were applied at the same time, in October (autumn application) with shallow incorporation before sowing and top-dressed in March (spring application). Spring application to potatoes was before planting, with shallow incorporation. Table 2 shows the average manure composition.

%	cattle manure	turkey litter	broiler litter	layer dry manure
DM	23.9	52.5	56.9	64.9
Total N	0.6	1.9	2.9	3.8
NH <sub>4</sub> <sup>+</sup> -N	0.1	0.8	0.7	0.6
P <sub>2</sub> O <sub>5</sub>	0.4	3.1	2.0	3.4
K <sub>2</sub> O	0.9	2.1	2.1	1.8
C/N ratio	1:14.9	1:12.7	1:8.8	1:6.5

*Table 2  
Composition of manures, given in % of fresh matter, and C/N ratio.*

The nitrogen efficiency of the animal manures was evaluated in comparison to a fitted response curve, calculated from spring applied fertiliser.

Fertiliser N was applied at mid of March for all autumn and spring treatments. Plot size was 42 m<sup>2</sup>, and 21 m<sup>2</sup> out of these were harvested. Soil mineral nitrogen (SMN) samples were taken after harvest down to a depth of 90 cm and analysed for NO<sub>3</sub><sup>-</sup>-N and NH<sub>4</sub><sup>+</sup>-N.

All treatments were fully randomised within 4 replicates. For the cereal crops, the results are shown on average of the three experimental sites and the four years. The statistical analysis showed no significant effect of the soil and the year factor on the yield. Potatoes were evaluated separately.

### 3. Results and discussion

#### 3.1. Timing of application

Fig. 1 shows the effect of manure application in autumn and spring on grain yield. Yield increased in the order cattle FYM < turkey manure < broiler manure < layer dry manure. The result was the same for autumn and spring application. On average of the four years, spring application was more favourable than autumn application. This was especially true for broiler litter and layer dry manure with their high content of soluble nitrogen. A high portion of layer dry manure nitrogen (about 30%) consists of soluble nitrogen (ammonia N and uric acid, CHAMBERS *et al.* 1994) which is easily mineralised to ammonium N and further to nitrate N under aerobic conditions. Soil mineral nitrogen dynamics after autumn application (fig. 2) point also in this direction. In autumn, soil mineral nitrogen (SMN) increased, due to N mineralisation in the soil. If cattle manure was applied, the release of nitrogen was higher than in the unfertilised plots; but it was significantly higher if layer dry manure was applied. The figure demonstrates also that, from a peak in December, a net loss of soil mineral nitrogen until spring occurred for all treatments. In this situation, on a sandy soil and a lot of rainfall over winter, it is supposed that at least a part of that loss was leached over winter. Differences in SMN amounts between years are mainly caused by variations in climatic conditions and cropping. In 1995, potatoes were grown, and mineralisation of the residues led to an enormous increase of SMN in autumn.

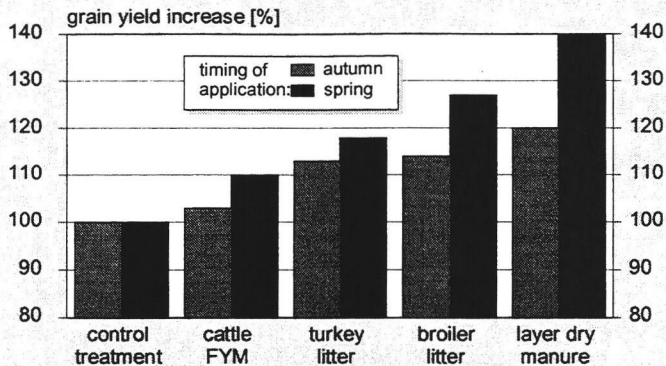

**Fig. 1: Effect of autumn and spring application of solid animal manures on grain yield**

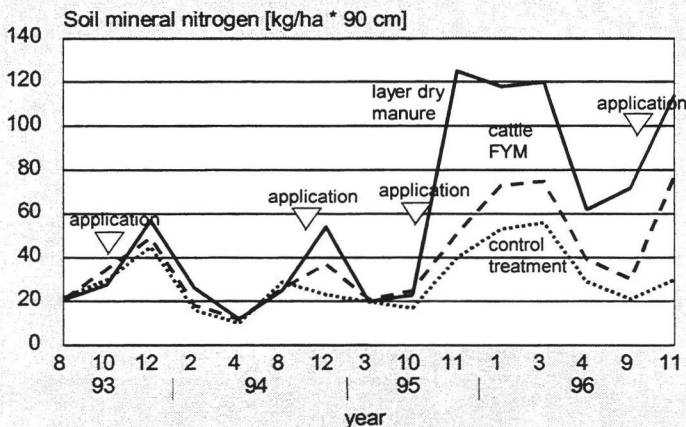

**Fig. 2: Effect of solid animal manure application each year in October on soil mineral nitrogen on a sandy soil.**

A lower nitrogen efficiency from autumn application of poultry manures was also reported by CHAMBERS *et al.* (1994). They found, however, that on heavy soils in low rainfall areas, autumn and spring application may not differ in nitrogen efficiency, due to fewer N leaching losses.

### 3.2. Mineral Fertiliser N equivalents

Nitrogen efficiencies are given as mineral fertiliser N equivalents. In fig. 3, the mineral fertiliser N equivalents for autumn and spring application to cereals of 100 kg/ha N as solid animal manures are shown. For cattle FYM (10-12 kg), only a

small difference could be found between spring and autumn application, due to its wide C/N ratio and low ammonia N content. For broiler litter and particularly for layer dry manure, spring application resulted in a much better N utilisation than autumn application. For application in spring, about 30 kg N per 100 kg of broiler litter N and about 50 kg N per 100 kg of layer dry manure could be accounted for.

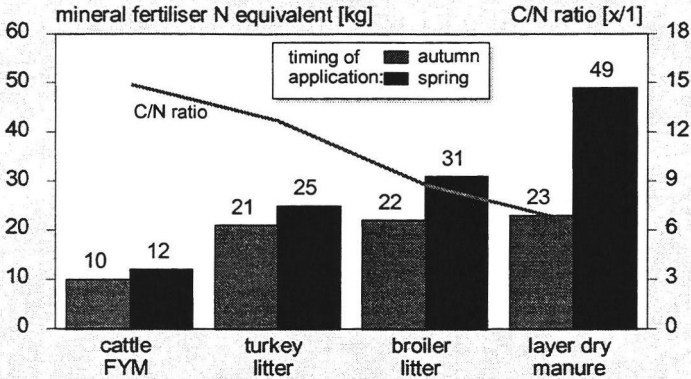

**Fig. 3: Effect of autumn and spring application of solid animal manures to cereals on mineral fertiliser N equivalents.**

Fig. 4 shows the effect of solid animal manures applied to potatoes. Spring application was much better than autumn application. With spring application, fertiliser N equivalents of 60-80 kg fertiliser N per 100 kg manure nitrogen could be obtained. However, this is only the result from a single harvest, but results with cattle FYM carried out in the past by various researchers show a better nitrogen utilisation by root crops like potatoes and sugar beet compared to cereals. Nitrogen mineralisation in spring comes usually too late to be of great importance for cereal nutrition.

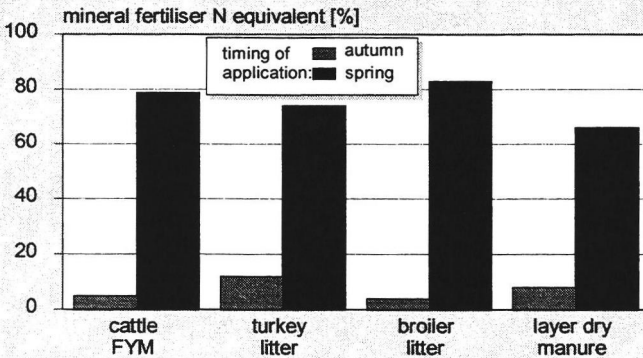

**Fig. 4: Effect of autumn and spring application of solid animal manures to potatoes on mineral fertiliser N equivalents.**

### 3.3. Addition of mineral fertiliser N

In the experiments, two manure N rates (100 and 200 kg/ha N) were each combined with three rates of fertiliser N (none, 40-60 kg/ha or 80-120 kg/ha N). Fig. 5 shows the effect on grain yield if either 100 kg/ha manure N or two different rates of fertiliser N had been applied additionally to 100 kg/ha of manure N applied in spring. For cattle FYM and turkey litter, the effect of additionally 100 kg/ha manure N (i. e. 200 kg/ha manure N in total) was smaller than the effect of additionally 40-60 kg/ha fertiliser N, whereas for broiler litter and for layer dry manure, additional manure N was able to increase the grain yield in about the same way as the small fertiliser N rate. A rate of 80-120 kg/ha fertiliser N increased the grain yield of all kinds of manure to about the level of optimum N fertilisation (max. yield). This yield, however, was obtained with a N rate of 130 kg/ha on average of the years. Additional fertiliser N was more efficient in those manures which were low in soluble nitrogen and high in C/N ratio, like cattle FYM and turkey litter. In general, it makes sense not to cover the crops' nitrogen demand with animal manure alone since this would lead to an over-supply with other nutrients like phosphorus and potassium.

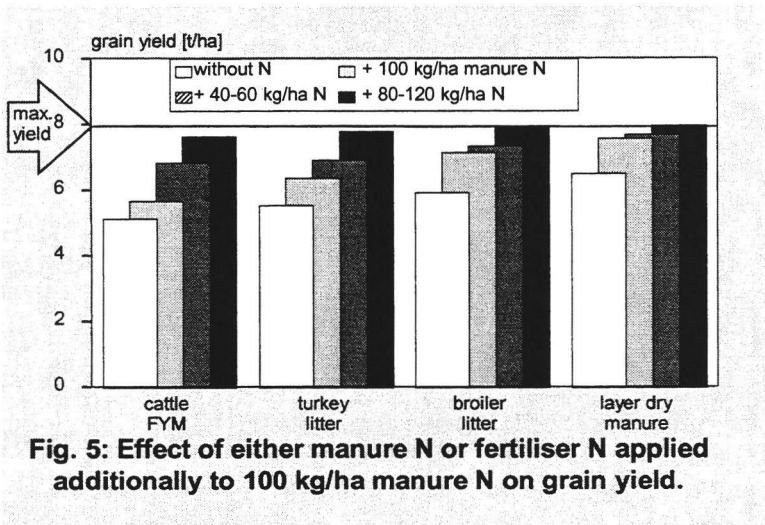

### 3.4. Soil mineral nitrogen after harvest

Rates of 100 kg/ha manure nitrogen (applied in spring) + 100 kg/ha mineral fertiliser N left about 50-60 kg/ha soil mineral nitrogen (SMN) after harvest (fig. 6); the amount of SMN after application of poultry manures exceeded the amounts from the optimal N treatment. From year to year subsequently increasing soil mineral nitrogen after harvest indicates a residual effect (fig. 7). Because of annual variation in growing conditions and thus varying nitrogen demand, further research is required to evaluate the residual effects with regard to the development of the nitrogen requirement for optimal yields.



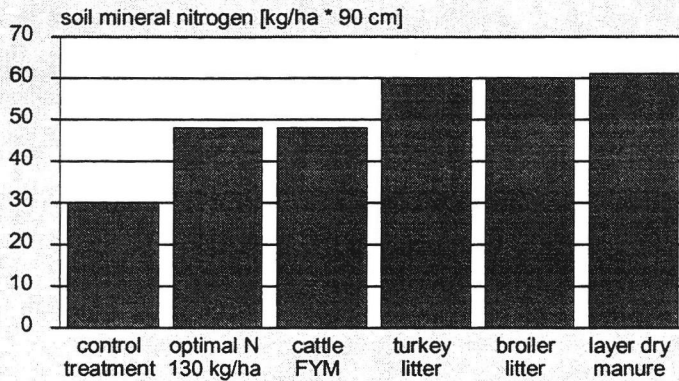

**Fig. 6: Effect of spring application of solid animal manures (100 kg/ha N) + 100 kg/ha additional fertiliser N to cereals on soil mineral nitrogen after harvest**

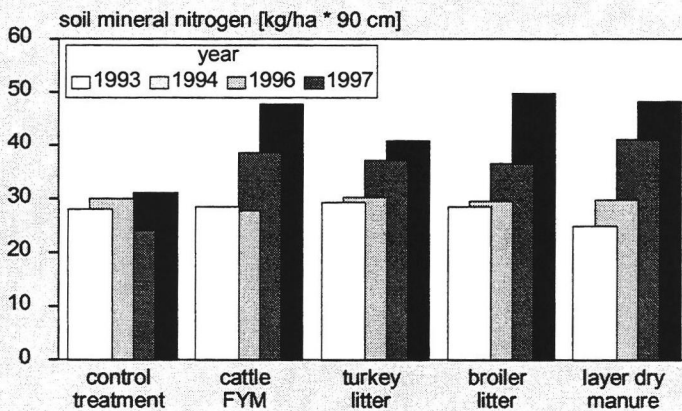

**Fig. 7: Increase of soil mineral nitrogen after harvest during the experiment (solid animal manure without additional N).**

#### 4 Reference

CHAMBERS, B. J., K. A. SMITH and R. B. CROSS (1994) Effect of poultry manure application timing on nitrogen utilization by cereals. In: HALL, J. E (ed.) *Animal Waste Management*, Proceedings of the Seventh Technical Consultation on the ESCORENA Network on Animal Waste Management, 199-205.

# **The effect of organic fertilization on the crop yields and soil properties**

*Effet de la fertilisation organique sur le rendement des cultures  
et sur les propriétés du sol*

**J. Klir, P. Ruzek**

Research Institute of Crop Production,  
Prague, Czech Republic  
E-mail : klir@hb.vurv.cz

**Irina A. Arkhipchenko**

Research Institute of Agricultural  
Microbiology, St Petersburg, Russia  
E-mail : bamil@riam.spb.su

## **Abstract**

*In the long-term field experiment at Prague-Ruzyne (since 1955), the effect of different organic fertilizers (farmyard manure, pig slurry, cattle slurry, poultry slurry, straw, compost) on the plant yields, nutrient uptake and nutrient status in soil has been investigated. In comparison to the variant with farmyard manure, a pig slurry application had the similar positive effect (direct for root crops and subsequent for cereals) on the nitrogen balance, nutrient efficiency and crop yields. Nitrate leaching and crop response to applied nitrogen has been studied in another field experiment on three different sites with annual application of various doses of pig slurry. The efficiency of N from slurry was practically identical to the efficiency of nitrogen from equivalent doses of industrial N-fertilizer, especially on clay loam and loam soils, but it was 2-3 times lower on sandy-loam soil.*

*The effect of different organic fertilizers on the yield of perennial ryegrass (*Lolium perenne* L.), nutrient status of the soil and nutrient uptake, has been investigated in green-house pot experiment. Manure (farmyard manure, pig slurry with and without straw, biofertilizer « Bamil », sewage sludge) was applied in the same amount of nitrogen (2 g N per one pot, with 5 kg of topsoil). The highest yield of ryegrass and simultaneously the highest nitrogen uptake was observed in the variant with pig slurry, followed by pig slurry plus straw, biofertilizer « Bamil », sewage sludge and farmyard manure.*

Keywords : manure, slurry, biofertilizer, yields.

## **Résumé**

Dans l'essai au champ de longue durée mis en place en 1955 à Prague-Ruzyne, l'effet de différents fertilisants organiques (fumier, lisier de porc, lisier bovin, lisier volailles, paille, compost) sur le rendement des cultures, l'utilisation des éléments et le statut du sol a été étudié.

Un apport de lisier de porc présente le même effet positif notamment vis à vis de l'utilisation de l'azote par les cultures, comparativement à l'application de fertilisants de synthèse, notamment sur sol argilo-limoneux et limoneux. L'effet azote sur sol sablo-limoneux était 2-3 fois inférieur à celui obtenu avec des engrais chimiques.

L'effet de différents fertilisants organiques sur le rendement de ray-grass permanent, (*Lolium perenne* L.), le statut nutritif du sol et l'utilisation des éléments, a également été étudié lors d'essais en laboratoire (culture sous serre de pots d'incubation).

Les rendements optimum en ray-grass et consécutivement l'absorption d'azote par la plante ont été les plus élevés avec le lisier de porc, suivi par lisier de porc + paille et par le biofertilisant « Bamil », puis par boues de station d'épuration et par le fumier.

Mots-clés : déjections, lisiers, biofertilisants, rendements.

## 1. Introduction

The average nutrients input from organic fertilizers has been nearly equal to the nutrients input from industrial fertilizers in Czech agriculture in years 1991 - 1996. It reached approximately 75 kg N + P<sub>2</sub>O<sub>5</sub> + K<sub>2</sub>O per 1 ha of agricultural land (or approx. 100 kg N + P<sub>2</sub>O<sub>5</sub> + K<sub>2</sub>O per 1 ha of arable land, as the main target of fertilization and manure application). The other sources of organic matter and nutrients in addition to the animal manure are as follows: treated public sewage sludges, urban composts from public garbage collection, industrial wastes, such as products from the food processing industry and other organic products used as fertilisers. The new type of organic fertilizer is represented by microbial biofertilizer, produced in bioreactors on the basis of animal excrements and/or other agricultural wastes.

## 2. Districtwise analysis of productivity, farmyard manure application and industrial fertilizer consumption in Czech agriculture

The analysis of current situation in plant nutrition, fertilization level and soil fertility status has been done on the basis of the official statistical data on the district level in the year 1995. There are 77 districts in the Czech Republic (4.28 mil. ha of total agricultural land, 3.14 mil. ha of arable land). According to the soil fertility and climatic conditions the area can be divided into three main groups of districts. The average yields of all harvested field crops were recalculated on the basis of their energy value to the « grain units » (1 GU is equivalent to 0,1 t of cereal grain). The

« agroecological production potential » represents the level of yield, which can be reached under conditions of optimal agricultural practice.

group of districts	number of districts	arable land area (in thousand ha)	production potential of soils (GU/ha)	yields in 1995 (GU/ha)	production potential utilization (%)
I	24	1136	65,7	52,6	80
II	23	920	51,4	44,7	87
III	30	1087	43,3	38,5	89
<b>total</b>	<b>77</b>	<b>3143</b>	<b>54,0</b>	<b>45,4</b>	<b>84</b>

GU = grain units = 0,1 t of cereal grain).

*Table 1  
Production potential and its utilization in 1995.*

The response to the industrial fertilizer consumption (kg of N + P<sub>2</sub>O<sub>5</sub> + K<sub>2</sub>O per 1 hectare of arable land) and to the farmyard manure application (t per 1 hectare of arable land) is shown in figures 1 and 2. The columns represents average yields in subgroups of districts grouped according to fertilization level and/or farmyard manure application expressed as the difference from the mean value of the main group. Because of decreasing of NPK fertilizer consumption, the role of organic fertilization as the plant nutrient source (figure 1) seems to be more important than the role of NPK fertilization (figure 2). The average input of nutrients from both sources is practically identical, but in the case of organic fertilizers the ratio between main elements is more suitable, and into the bargain, by the organic fertilizers farmers supply to the soil other active substances (organic matter, microbes, enzymes etc.).

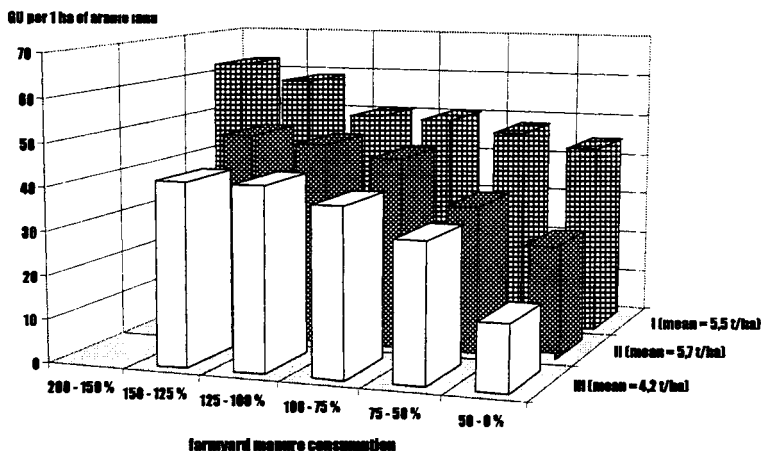

*Figure 1  
The effect of farmyard manure on crop production*

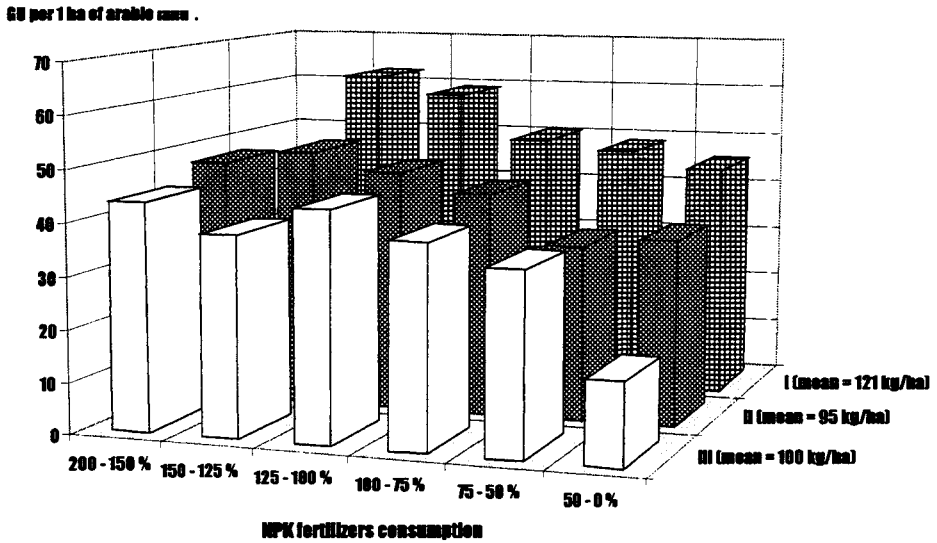

Figure 2  
The effects of N P K fertilizers on crop production

### 3. Animal manure and organic waste nutrients inputs in Czech agriculture

Animal manure and organic waste nutrients inputs in Czech agriculture has been calculated according to the OECD balancing method. The "soil surface nutrient balance" is one of the priority issues in developing an OECD set of agri-environmental indicators, as part of the contribution to the analysis of the interactions between agriculture and the environment and impact of changes in agricultural policy on the environment. The soil surface balance calculates the difference between the total quantity of nutrient inputs entering the soil and the quantity of nutrient outputs leaving the soil annually. The calculation of the soil surface balance is a modified version of the so called "gross balance", which provides information about the complete surplus (deficit) of nutrients into the soil, water and air from an agricultural system.

A soil surface N, P, K balance for the Czech Republic in the years 1985 - 1997 was calculated on the base of official statistical data (fertiliser use, sewage sludge and wastes application, numbers of live animals in terms of different categories according to species, sex, age and purpose, quantity of harvested crops and forage) and converse coefficients (animal excrements production, nutrients content, nitrogen fixation and deposition).

The annual total quantity of nutrients inputs for the soil surface nutrients balance includes in addition to *industrial fertilizers, nutrients contained in seeds and planting materials, atmospherical nutrient deposition and biological nitrogen fixation* other sources as follows :

- *net input of manure* = livestock manure production – manure withdrawals (manure withdrawn from agriculture and not applied to agricultural land, destruction of manure and evaporation of ammonia which occurs from stored manure and livestock housing)
- *nutrients from recycled organic matter* (treated public sewage sludge, urban compost from public garbage collection, industrial waste, such as products from the food processing industry and other organic products used as fertilisers)

Recycled organic matter used in agriculture	% in dry matter		
	N	P <sub>2</sub> O <sub>5</sub>	K <sub>2</sub> O
Sewage sludge	4	2,5	0,4
Urban compost	1,5	0,4	0,5
Industrial waste products	1,5	1,4	1,5
Other products	1	0,6	0,3

*Table 2.  
Average nutrient content of organic wastes.*

The results of organic wastes and manure nutrients balances are shown in figures 3 - 6.

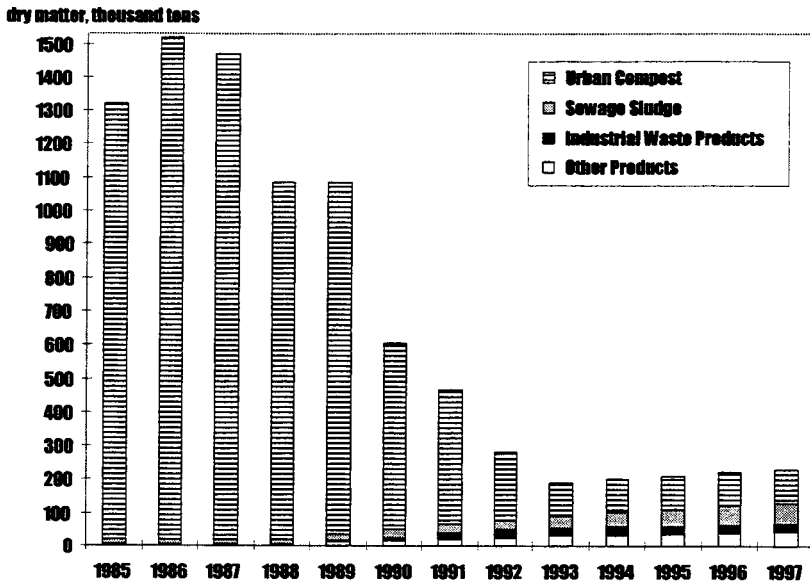

Figure 3  
Organic waste recycling in Czech agriculture

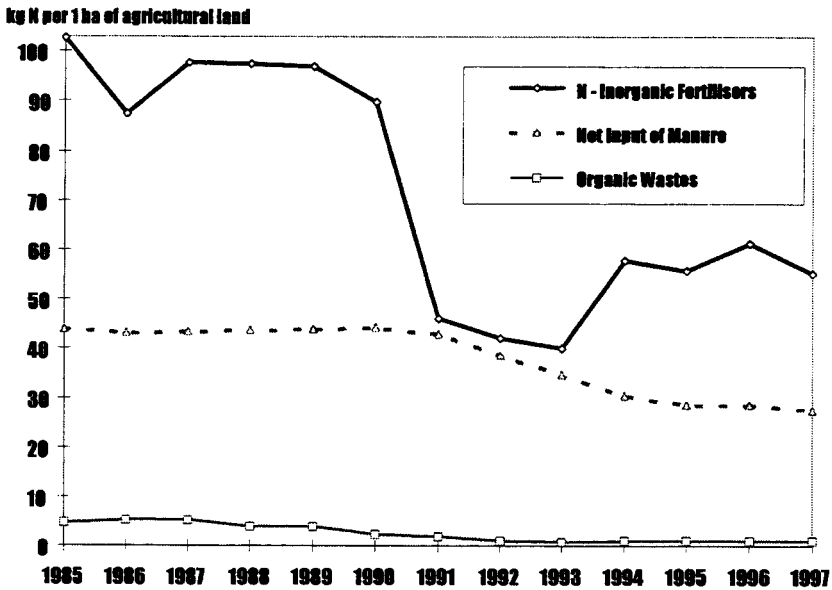

Figure 4  
Nitrogen inputs in Czech agriculture

kg P<sub>2</sub>O<sub>5</sub> per 1 ha of agricultural land

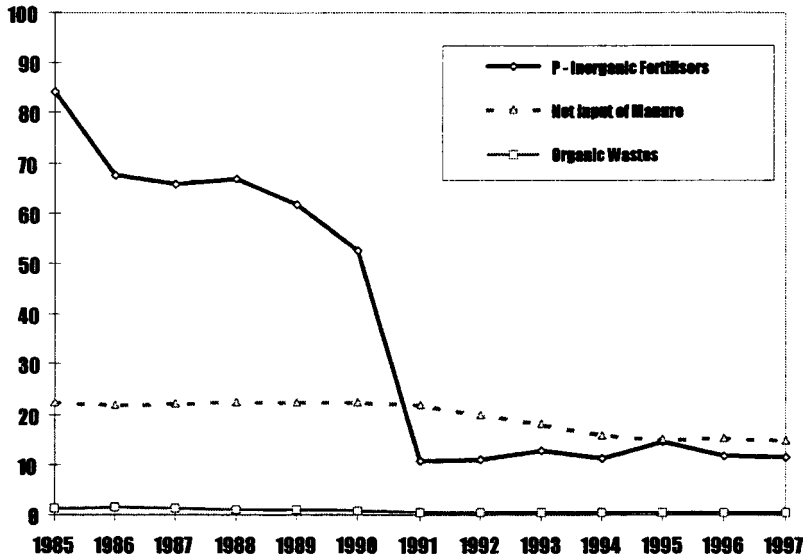

Figure 5  
Phosphorus inputs in Czech agriculture

kg K<sub>2</sub>O per 1 ha of agricultural land

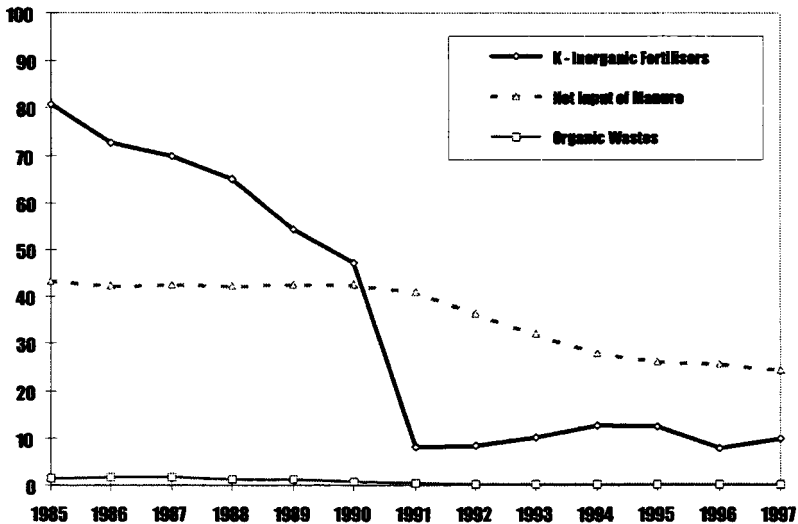

Figure 6  
Potassium inputs in Czech agriculture



#### **4. Nitrogen utilization from organic fertilizers in pot experiments**

The effect of different organic fertilizers on the yield of perennial ryegrass (*Lolium perenne* L.), nutrient uptake by plants and nutrient status of the soil has been investigated in green-house pot experiment. Manure (farmyard manure, pig slurry with and without straw, biofertilizer « Bamil », sewage sludge) was applied in the same amount of nitrogen (2 g N per one pot, with 5 kg of topsoil). Tested fertilizers were pig slurry (0.55 % N in raw material), farmyard manure (0.39 % N), stabilized solid sludge (0.84% N), biofertilizer « Bamil » (product of Scientific & Technological Centre "NIKA", St.Petersburg, Russia, which is pelletized biofertilizer from products of aerobic treatment of pig farm wastes, 3.9 % N). The control variants were PK and urea (46 % N) + PK.

The highest yield of ryegrass and simultaneously the highest nitrogen uptake from the organic fertilizer was observed in the variant with pig slurry, followed by pig slurry plus straw, sewage sludge, biofertilizer « Bamil » and farmyard manure (figure 7). After application of microbial pelleted biofertilizer « Bamil », successive mineralization and nitrification of organic N was observed, without nitrate accumulation in soil solution and with low nitrate content in the plants (figures 8 and 9).

The effect of the new biofertilizer « Bamil » has been studied although in the course of biological recultivation of various types of man-made violations of soils in the industrial regions of the north-western Czechia. It was marked with the increase of yield in dry weight of grasses, biological activity of soil, reduced removal of nitrates from soil, as well as prolonged effectiveness of fertilizer - gradual mobilization of nutrition elements, primarily nitrogen.

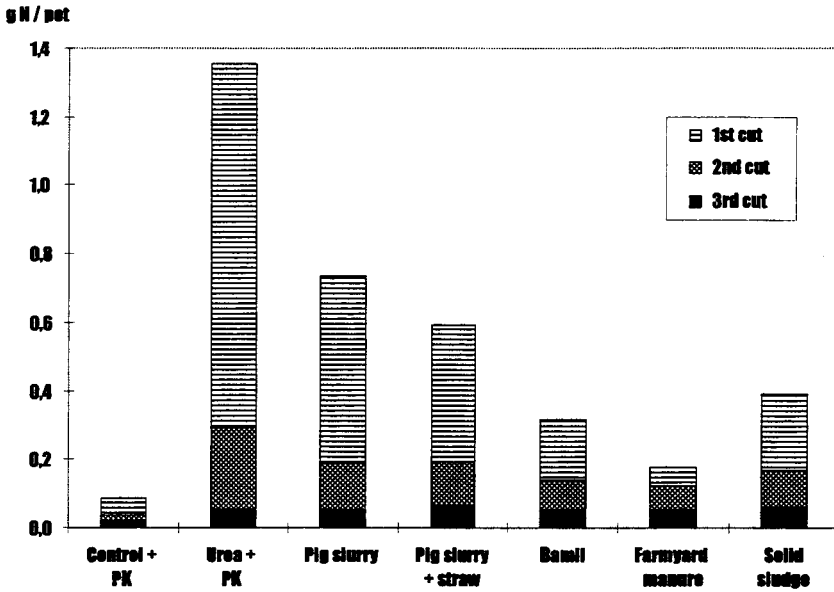

Figure 7  
Nitrogen uptake by plants

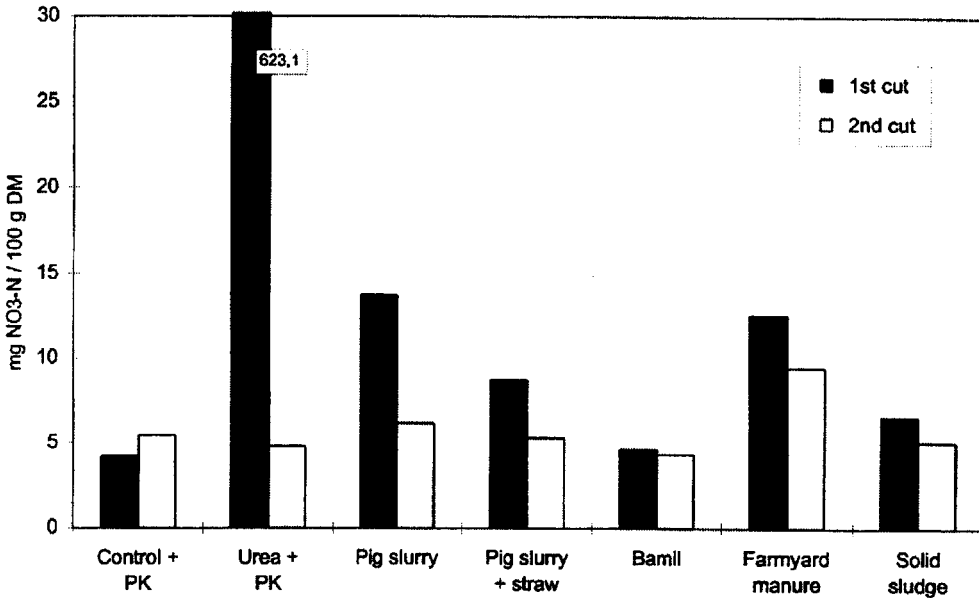

Figure 8  
Nitrate content in plants

mg NO<sub>3</sub>-N/l

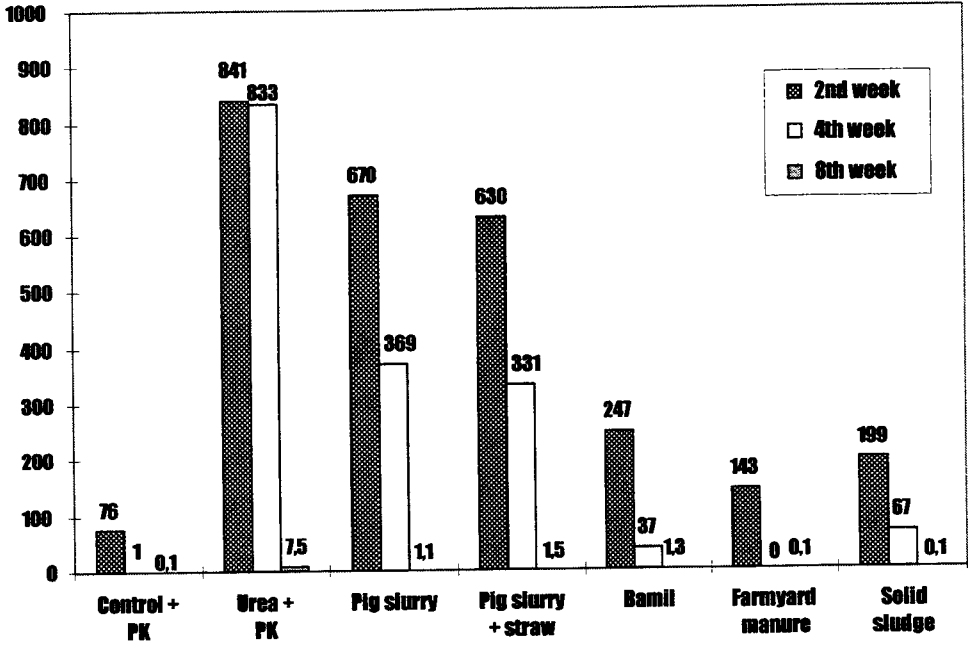

Figure 9  
Nitrate content in soil solution

## **Composting of swine slurry : firsts results.**

*Compostage du lisier de porc : résultats préliminaires.*

### **Paolo Balsari**

Università degli Studi of Torino  
Dipartimento di Economia e Ingegneria  
Agraria Forestale e Ambientale  
Sezione di Meccanica  
via Leonardo Da Vinci,  
44 - 10095 - Grugliasco. Italy  
E-mail : pbalsari@mbox.sicap.it

### **Gianfranco Airoidi**

Università degli Studi of Torino  
Dipartimento di Economia e Ingegneria  
Agraria Forestale e Ambientale  
Sezione di Topografia e Costruzioni  
Rurali via Leonardo Da Vinci,  
44 - 10095 - Grugliasco. Italy

## **Abstract**

*Stricter legislation on disposal of pig slurry has stepped up the search for solutions that make it possible to produce compost instead of slurry and above all in structures outside the swine rooms, which do not involve far-reaching modifications to building design and swine management. In view of the unsatisfactory results obtained with biological oxidization of pig slurry on a bed of wood shavings, other methods must be identified. Liquid manure with a low TS content ( $\leq 6\%$  in the case of pig slurry) must be mixed with straw for sorption of water and formation of a porous structure that can be used for composting. In the classical composting process, the material must be placed in windrows and a turning machine is required to add, mix and turn the substrate. To reduce composting costs, the process was divided into a sorption phase, in which the slurry was added to the substrate, and a maturing phase, in which the material was collected, forming a stack. An experiment based on this technique was carried out in 1997 at a piggery in the Western Po Valley using Winter wheat straw and corn stalk as substrate and forming a  $25\text{-kg/m}^2$  layer on a  $50\text{-m}^2$  covered concrete platform surrounded by a 20-cm high kerb. In the sorption phase,  $240\text{ l/m}^2$  of slurry were added to the substrate on three occasions ( $120\text{ l/m}^2$  just after formation of the layer of substrate and  $60\text{ l/m}^2$  twice, at an interval of 15 days). After the 45-day sorption period, a 1.5-high stack was formed with the material. A period of 8 weeks was required for the maturing phase, after which  $64\text{ kg/m}^2$  of compost were obtained with a 26% TS content.*

## **Résumé**

Les réglementations contraignantes liées à l'utilisation du lisier de porc amènent à considérer des solutions alternatives telles que la production de compost à l'extérieur des bâtiments.

L'effluent d'élevage avec une teneur en matière sèche inférieure à 6% (notamment pour le lisier de porc) doit être mélangé à de la paille lors d'une étape d'absorption de l'eau et production d'une structure poreuse utilisable lors du compostage.

Dans notre étude, le procédé de compostage était ainsi divisé en une étape d'absorption au cours de laquelle le lisier est mélangé au substrat et une phase de maturation. Un premier essai basé sur cette approche a été effectué en 1997 dans une exploitation porcine de la vallée ouest du Pô en utilisant de la paille de blé et des résidus de maïs en tant que substrat et en formant ainsi une couche de 25 kg/m<sup>2</sup> sur une surface de 50 m<sup>2</sup> en plateforme béton.

Lors de la phase d'absorption 240 l/m<sup>2</sup> de lisier sont ajoutés au substrat en 3 fois (120 l/m<sup>2</sup> juste après formation couche de substrat et 2 fois 60 l/m<sup>2</sup> à intervalles de 15 jours).

Après 45 jours de période d'absorption, un tas de 1,5 m de hauteur a ainsi été constitué. Une période de 8 semaines était nécessaire pour la phase de maturation, à la suite de laquelle on obtient 64 kg/m<sup>2</sup> de compost présentant un taux de MS de 26%.

## 1 - Foreword

In the last few years, pig breeders have shown increasing interest in waste management methods that do not produce slurry, disposal of which is now regulated by ever tighter restrictions with therefore increasingly higher costs.

Different researches and experiments undertaken recently for stabling of pigs on litter have revealed that, although this solution is effective for service houses, pregnant sow houses and weaner houses (*Navarotto & Al.*, 1991; *Simoni*, 1993), it cannot be used for rearing and fattening houses (*Bonazzi & Navarotto*, 1992; *Bonazzi & Navarotto*, 1993). Also, at existing piggeries, this solution involves expensive modifications to the swine rooms. Hence, the considerable interest shown at the moment in solutions that make it possible to transform pig slurry into manure or compost using structures outside the buildings in which the animals are housed (*Piccinini et Al.* 1995; *Balsari et Al.* 1996).

Composting could represent an effective solution to problems of pig slurry disposal in areas with a high animal population, making it possible to transfer the organic substances and excess nutritional elements towards areas where there is a shortage of these. The end product has a high content of total solids and good fertilizing characteristics such as to make transport of this, even over long distances, economically viable.

For example, it could be used in agriculture as fertilizer for herbaceous and tree crops - the most probable solution, characterized by the greatest opportunities for placement - or as a component for the production of composts for both vegetable and flower growers, as well as for recovery of downgraded areas and maintenance of public parks and gardens.

However, transformation of pig slurry into compost entails a number of difficulties to be ascribed mainly to its high moisture content which means that it must be mixed with byproducts of vegetable origin available directly at the farm such as wheat straw and corn stalks or outside this (pruning shoots and material resulting from maintenance of public parks and gardens and recovery of wood packing material), even if the quality and effective availability of these materials in the quantities required must however always be checked.

## **2 - The trial carried out**

When organizing this experiment, reference was made to an experiment carried out in Northern France with satisfactory results (Callarec, 1996). The experimentation was carried out on a 50 m<sup>2</sup> (10 x 5 m) cement platform with a 1% slope with direction normal to the long side (to permit collection of waste liquid in two underground cylindrical tanks with a total volume of 0.2 m<sup>3</sup>). The platform was equipped with protective kerbs to prevent any risk of percolation of the slurry in the water table.

The experiment was carried out using two different types of substrates: wheat straw and a mixture of wheat straw and corn stalks.

In both trials the substrate was distributed on the platform. and then pig slurry was applied on three occasions at an interval of about 15 days. Each distribution of slurry was followed by mixing of the mass using a straight blade hoe hooked to a tractor (sorption phase). Fifteen days after the last application, the material was placed on a maturation platform in stacks maturing period (fig.1).

During both the experimental periods they were recorded :

- distributed substrate main chemical characteristics (TS, total nitrogen);
- applied slurry main chemical characteristics (TS, VS, total nitrogen, ammonium nitrogen, pH);
- substrate temperature during the maturing phase (every week) by thermocouples LSI PT-100 finked to a digital thermometer;
- substrate main chemical characteristics (TS, VS, total nitrogen, ammonium nitrogen, pH, C/N ratio) at the end of sorption period and at the end of the maturing phase.

All input and output materials were weighted for mass balance determinations.

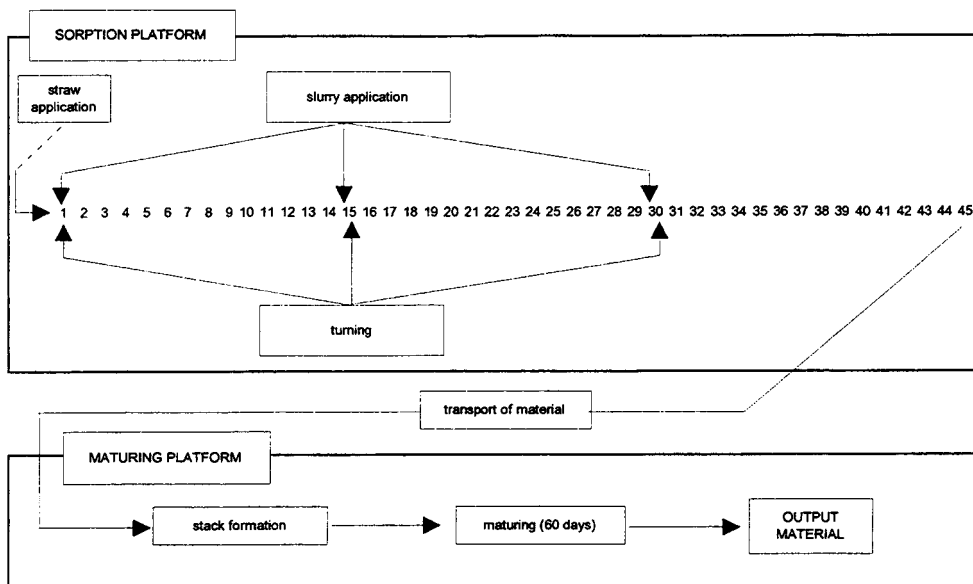

Figure 1  
Diagram of the thin layer bed management.

## 2.1 - Test with wheat straw

At the start of the test on February 4 (day 0), 1.25 t of straw and 5.8 m<sup>3</sup> of slurry at 6% of TS were distributed on the platform. After fifteen days, 3.3 m<sup>3</sup> of pig slurry at 8.2% TS were added while 3.2 m<sup>3</sup> of slurry at 1.7% of TS were distributed 36 days later (tab. 1), with a delay of one week on the date planned because of slow absorption of the slurry by the straw substrate. On day 0+51, the material was stacked and a representative sample of the mass was taken.

	Slurry application		
	day 0	day 0 + 15	day 0 + 36
TS (%)	6.08	8.23	1.70
VS (%)	4.00	5.55	0.97
Total nitrogen (%)	0.55	2.68	0.29
Ammonium nitrogen (%)	0.32	1.71	0.17

Table 1  
Test with wheat straw: chemical characteristics of slurry applied

Another sample was taken on day 0+169 when it was decided to end the test in that the temperature of the stack had reached a value slightly above ambient temperature. (fig. 2).

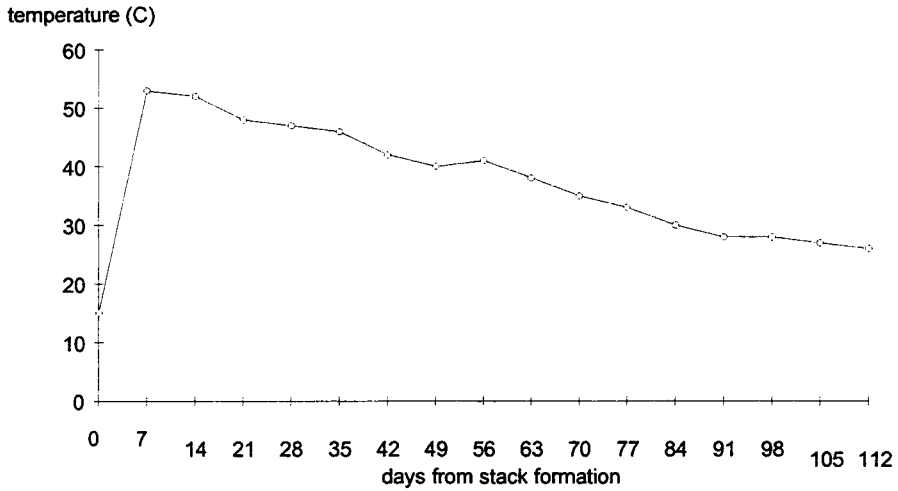

**Figure 2**

*Test with wheat straw: temperature evolution during maturing period.*

During the experiment, 12.3 m<sup>3</sup> of pig slurry were distributed on 1250 kg of wheat straw corresponding to a total mass of 13550 kg. At the end of the experiment, i.e. after 169 days, the total weight of the mass present inside the pilot system was 3840 kg. This value corresponded to a dry substance and nitrogen loss of 45% and 60% respectively (tab. 2)

materials	wet basis (kg)	dry matter (kg)	total nitrogen (kg)
substrate	1250	1087.5	6.5
slurry	12300	678.6	57.0
input material	13550	1766.1	63.5
output material	3840	976.9	25.3
output/input	28.3%	55.3%	39.9%

**Table 2**

*Test with wheat straw: mass balance of the experiment.*



The fraction of pig slurry distributed lost through draining off the platform of the pilot system was negligible. Briefly, during this first test, around 10 kg of pig slurry were disposed of by one kilogram of wheat straw. Assuming a slurry production per head of 0.54 kgTS and an effective duration of the process cycle equal to that of the test, this value corresponds to a requirement of 2 m<sup>2</sup> of covered surface per head and to use of 1 kg/head.day of wheat straw.

The analyses of the samples examined revealed that at the end of the sorption phase (on day 0+51), the substrate had not yet stabilized (C/N > 23; organic carbon = 45.6%). On the other hand, at the end of the maturing period (i.e. at the 169<sup>th</sup> day), the organic carbon and C/N ratio values were within the limits regarding compost quality of Italian regulations (DLGS 22/97). Nevertheless, the TS content (25.44 against minimum of 60%) and the pH (9.50 against a permitted range of variation of 5.5-8) deviated considerably from the values indicated (tab 3).

parameters	sampling time	
	end of sorption period	end of maturing period
Total Solids (% WB)	23.52	25.44
Volatil Solids (% DM)	82.07	60.52
Aches (% DM)	17.93	39.48
Organic Carbon (% DM)	45.60	33.62
pH	9.50	9.50
Total Nitrogen (% ss)	1.91	2.37
C/N	23.88	14.17

*Table 3*  
*Test with wheat straw: analytical results of the experiment.*

Briefly, the material obtained is odorless and can, to all effects and purposes, be considered manure, which, as such, can be used at the farm or in areas close to this, whereas possible sale as compost or transport over long distances requires further drying until an TS content of around 50% is reached.

## **2.2 - Test with wheat straw and corn stalks**

At the start of the test on August 12 (day 0), 550 kg of straw, 880 kg of corn stalks and 7.7 m<sup>3</sup> of slurry at 3.5% of TS were distributed on the platform of the pilot system. On day 0+14, 3.5 m<sup>3</sup> of slurry at 2.8% of TS were distributed while on day 0+35, with a delay of one week on the planned date because of slow absorption of the slurry, 2.8 m<sup>3</sup> of slurry at 9.5% of TS were distributed (tab. 4).

	slurry application		
	day 0	day 0+15	day 0+36
TS (%)	3.54	2.80	9.55
VS (%)	2.01	1.54	5.85
Total nitrogen (%)	0.36	0.32	0.44
Ammonium nitrogen (%)	0.22	0.19	0.29

*Table 4*

*Test with substrate of straw and stalks: chemical characteristics of slurry applied*

On day 0+49, the material was stacked and a representative sample of the mass was taken. On day 0+106, as the temperature of the stack was close to 20°C, the test was considered as completed and a sample was taken to determine product physical-chemical characteristics (fig. 3).

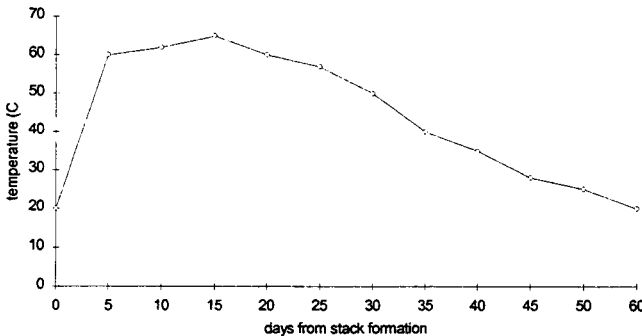

*Figure 3*

*Test with substrate of straw and stalks: temperature trend during maturing period.*

During the experiment, a total of 14 m<sup>3</sup> of slurry were distributed on 1430 kg of substrate, corresponding to a total mass inserted in the system of more than 15400 kg. At the end of the experiment (i.e. after 106 days), the material inside the pilot system weighed 4370 kg. Therefore, in the more than 3 months of the process, an approximate 72% weight reduction was obtained; also, the loss of dry substances was close to 48% with a 54% loss of nitrogen (tab. 5)

materials	wet basis (kg)	dry matter (kg)	total nitrogen (kg)
substrate	1430	1244.1	8.2
slurry	14040	642.2	51.6
input material	15470	1886.3	59.8
output material	4370	981.1	27.5
output/input	28.2%	52.0%	46.1%

*Table 5*

*Test with substrate of straw and stalks: mass balance of the experiment.*

The amount of pig slurry composted by one kilogram of substrate (straw + corn stalks) was close to 10 liters. Assuming a daily production per pig raised of 0.54 kgTS, this means that 2.1 m<sup>2</sup>/head of bed surface per pig raised are required and that 1.2 kilograms of substrate per pig raised must be inserted in the system each day.

The analytical data of the samples examined revealed that at the end of the sorption phase (on day 0+49), the substrate was already sufficiently stabilized and characterized by organic carbon (35.73) and C/N ratio (17.02) values within the compost quality limits. In this test also, the related values of total solids and pH of the material (21.4 and 9.3 respectively) at the end of the maturing period (106<sup>th</sup> day) were such that the product obtained cannot be classified as compost in our country.

Compared with the experiment carried out using only wheat straw as substrate, faster downgrading of the organic substance was observed with values of C/N and organic carbon on the dry substance very close to those of a compost already at the end of the composting period (49<sup>th</sup> day) (tab. 6).

parametrs	sampling time	
	end of sorption period	end of maturing period
Total Solids (% WB)	20.87	21.45
Volatil Solids (% DM)	64.32	56.58
Aches (% DM)	35.68	43.42
Organic Carbon (% DM)	35.73	31.44
pH	9.50	9.70
Total Nitrogen (% ss)	2.10	1.58
C/N	17.02	16.87

*Table 6*

*Test with substrate of straw and stalks: analytical results of the experiment*

### **3 - Remarks on the results obtained**

The results achieved during the preliminary tests revealed that composting of pig slurry on beds of limited thickness makes it possible to obtain, in short times and with limited use of substrate, a product similar to manure which can therefore be distributed on agricultural land without any legal constraints.

An initial outline economic assessment of this operating system, carried out assuming a 2000 m<sup>2</sup> system able to manage the slurry produced by a fattening piggery of 1200 heads, returned a management cost of the entire system of around 14 ECU/m<sup>3</sup> of slurry treated, whereas the production cost of the manure would be close on 45.2 ECU/t; a cost that has a 12.2% incidence on the Gross Income (calculated assuming a price of the pig of 1.3 ECU/kg).

These values could be considerably reduced assuming zero cost of the substrate (the farmer who picks up the manure at the end of the cycle provides the straw required to produce it). In this case, the cost for the breeder would drop to 6.4 ECU/m<sup>3</sup> of slurry treated with a 5.5% incidence on the Gross Income.

Lastly, assuming that at least half of the substrate used is produced at the farm and that the product obtained at the end of the process (manure) is sold on the market at 10.2 ECU/t from the farm, the cost of treating the slurry would be 7,6 ECU/m<sup>3</sup>, with therefore a 6.6% incidence on the Gross Margin.

#### **4. References**

**Balsari P., Airoidi G., Bonazzi G., Navarotto P.L.** (1996) - Risultati di prove di biossidazione controllata di liquami suinicoli su substrato ligno-cellulosico - Rivista di Ingegneria Agrari n. 1 (20-29)

**Bonazzi G., Navarotto P.L.** (1992) - Lettieria con trucioli di legno per suini in accrescimento - finissaggio - L'informatore Agrario n. 34 (51-55)

**Bonazzi G., Navarotto P.L.** (1993) - Lettieria profonda per suini a ingrasso - L'informatore Agrario n. 10 (35-46)

**Burton C.H.** (1992) - A Review of the Strategies in the Aerobic Treatment of Pig Slurry: Purpose, Theory and Method - Journal of Agricultural Engineering Research, n. 53 (249- 272)

**Callarec J.** (1996) - Traitement du lisier de porc par compostage - Chambres d'agriculture EDE de Bretagne (400-403)

**Evans M.R., Svoboda I.F., Baines S** (1982) - Heat from Aerobic Treatment of Piggery Slurry - Journal of Agricultural Engineering Research, n. 27 (45-50)

**Navarotto P.L., Piva G.F., Bonazzi G., Giuliani A.E.** (1991) - Un nuovo tipo di lettiera per eliminare la produzione dei liquami nelle porcilaie - L'informatore Agrario n.1 (32-35)

**Piccinini S., Rossi L., Valli L.** (1995) - Compostaggio dei reflui bovini, suini e avicoli - L'informatore Agrario n. 21 (27-33)

**Simoni A.** (1993) - Allevamento di suini in stalletti con lettiera permanente e tradizionali - Rivista di Suinicoltura n. 2 (65-70)  
Decreto Legislativo n.22 del 1997.

## Emission of ammonia, nitrous oxide, methane and carbon dioxide during composting of deep litter

*Emissions d'ammoniac, de protoxyde d'azote, de méthane et de dioxyde de carbone au cours du compostage de litière.*

**Sven G. Sommer, Preben Dahl, Hans B. Rom and Henrik B. Møller,**  
Research Centre Bygholm Danish Institute of Agricultural Sciences  
Department of Agricultural Engineering  
P.O. Box 536. 8700 Horsens  
E-mail: SvenG.Sommer@agrsci.dk. Telephone: 75602511. Telefax: 75624880

### Abstract

*During storage of solid animal manure, biological transformation of nitrogen and carbon may increase the temperature to 60 to 70°C, i.e. composting. The rise in temperature may cause a substantial loss of ammonia, as the ammonium is transformed to ammonia at high temperatures and because the heat is generating a flow of air through the dung heap. In the present study emission of ammonia, carbon dioxide (CO<sub>2</sub>), nitrous oxide (N<sub>2</sub>O) and methane (CH<sub>4</sub>) was measured using dynamic chambers covering three heaps of deep litter from a house with dairy cows. The heaps were either mixed after 30 days, compressed or untreated. Compaction of the very porous material enhanced the temperature increase in the heap. Ammonia emission was therefore high from the compacted heap giving a cumulated NH<sub>3</sub> loss of 0.2 kg N ton<sup>-1</sup>. Initially temperature also increased in the heap being turned after 30 days, and in total the NH<sub>3</sub> losses from this heap were similar to losses for the compressed litter. Only, half this amount was lost from the heap in which the temperature did not increase much initially. High amounts of carbon dioxide were emitted during composting of the deep litter, the cumulated losses were 33 kg C, 20 kg C and 17 kg C from the litter being mixed after 30 days, compressed deep litter and untreated deep litter. High nitrous oxide emission were determined when the initial high temperature declined, indicating that nitrifiers are affected by the high temperatures during composting. Elevated CH<sub>4</sub> emission were observed after a period of 15 to 30 days. Methane and nitrous oxide was emitted at a ratio of 1.6 to 39.9 g CH<sub>4</sub>-C day<sup>-1</sup> tonne<sup>-1</sup> and 0.04 to 10 g N<sub>2</sub>O-N day<sup>-1</sup> tonne<sup>-1</sup>.*

### Résumé

Au cours du stockage de déjections animales solides, les transformations biologiques de l'azote et du carbone aboutissent à une augmentation de la température pouvant aller jusqu'à 60-70°C i.e. compostage. Cette augmentation de température peut entraîner des pertes importantes sous forme d'ammoniac. Dans

notre étude, les émissions d'ammoniac, de dioxyde de carbone (CO<sub>2</sub>), de protoxyde d'azote (N<sub>2</sub>O) et de méthane (CH<sub>4</sub>) ont été mesurées à l'aide de chambres dynamiques couvrant trois tas de litière profonde provenant d'un bâtiment de vaches laitières. Les tas étaient agités après 30 jours, compressés ou non traités. La compaction d'un matériel poreux favorise l'augmentation de température dans le tas. Les émissions d'ammoniac issues du tas compacté étaient alors plus importantes et aboutissent à des pertes cumulées en NH<sub>3</sub> de 0,2 kg N tonne.

La température initiale augmente également dans le tas retourné ce qui aboutit à des pertes ammoniacales similaires à celles observées avec le tas compacté. Seulement la moitié de cette quantité d'NH<sub>3</sub> était émise dans le cas où la température dans le tas n'augmente pas.

Des quantités importantes de CO<sub>2</sub> ont été mesurées au cours du compostage de cette litière avec des pertes de 33 kg C, 20 kg C et 17 kg C respectivement à partir de litière agitée après 30 jours, compactée ou non perturbée.

Des pertes importantes en N<sub>2</sub>O ont été mesurées lorsque la température initiale élevée commence à décliner, indiquant que les nitrifiants sont inhibés par les températures élevées observées au cours du compostage.

Le méthane et le protoxyde d'azote étaient émis à des taux de l'ordre de 1,6 à 39,9 g C-CH<sub>4</sub> tonne<sup>-1</sup>.jour<sup>-1</sup> et 0,04 à 10 g N-N<sub>2</sub>O tonne<sup>-1</sup>. jour<sup>-1</sup>.

## 1. Introduction

The policy of the Danish government is to increase the share of organic farms to 10 % of the area under cultivation. Mineral fertilisers are not accepted for plant production within organic farming. Thus, limitation in the amount of nutrients available may contribute to reductions in crop yield and of animal production within organic farming. Nitrogen can be supplied through nitrogen fixation of leguminous plants, and at present, organic farms may import nutrients in roughage (cf. regulation on organic soil production).

A substantial amount of the nutrients needed by the crops in rotation are supplied in animal manure produced by animals feed with imported or produced roughage. The nutrients that are lost from livestock manure are irreplaceable, and losses will therefore reduce plant production on organic farms. Deep bedding and slurry are the two most common types of organic manure at organic farms. In organic farming there is a tradition to transform deep litter into compost. As far as we know, there are few studies of nitrogen losses and transformation of the nutrients in farmyard manure during composting. Traditionally composting processes and gaseous emission of oxidised and reduced nitrogen has been measured in compost of

municipal litter and livestock manure being turned frequently, often several times each week (Hellman *et al.* 1997; Martin and Dewes, 1992). In farming systems the deep litter being stored will not be turned at all or in organic farming normally only one time after about 1 month of composting.

Gaseous emission of carbon dioxide, methane and nitrous oxide has been quantified in this study . A movable dynamic chamber was used to determine gaseous losses. Techniques for reducing the losses was tested.

## 2. Methods

Gas emission during composting of deep litter was studied in three pilot scale dung-heaps of deep litter from housing of dairy cows. The litter was stored on a sealed surface (L: 4 m, W: 2 m) with collection of runoff to closed containers buried in the soil. In table one is given the amount and composition of the deep litter used in this experiment. In the experiment starting the 29th of September 1997 the deep litter was mixed by treating the material three times with a manure spreader on the initiation day of the experiment, immediately after this treatment the litter was stored under the following conditions 1) compressed, 2) mixed by turning the litter manually after 3 weeks and 3) untreated.

Treatment	Amount	DM	Ash	Tot-N	NH <sub>4</sub>	NO <sub>3</sub>	P	K	C
	Tonnes								
Compressed	0.980	379.35	52.83	7.50	0.63	0.13	1.21	11.95	160.26
		(47.31)	(6.32)	(1.13)	(0.04)	(0.04)	(0.20)	(1.26)	(24.24)
Mixed	0.660	408.55	59.43	8.30	0.60	0.25	1.40	13.67	172.35
		(11.24)	(2.29)	(0.14)	(0.04)	(0.04)	(0.02)	(0.48)	(4.75)
Untreated	0.720	421.65	60.87	8.36	0.54	0.20	1.43	13.54	177.87
		(0.64)	(0.42)	(0.34)	(0.03)	(0.00)	(0.03)	(0.12)	(0.86)

Table 1.

*Amount and composition of the stored deep litter from dairy cow houses.*

*The deep litter was compressed, mixed after 30 days and kept untreated, the volume of the deep litter heaps were 3 m<sup>3</sup>, 3.2 m<sup>3</sup> and 3.6 m<sup>3</sup>, respectively. (In bracket S.D., N=2).*

At the initiation of the experiment 2 samples of organic material each of 2 L, were taken from each dung heap. The samples of organic material were stored at -18°C. For the determination of CH<sub>4</sub>, N<sub>2</sub>O, CO<sub>2</sub> and O<sub>2</sub> from the centre of the heap gas samples were collected by modifying the technique of Petersen *et al.* (1998). The two ends of a flexible, but rigid plastic tube (i.d. 10 mm) containing 4 x 2 mm holes per cm length were connected to two 2 m lengths of gas-tight teflon tubes (i.d. 2 mm), the teflon tubes were connected to a diaphragm pump (Model 5002, ASF GmbH, Germany). At initiation of the experiment a silicone tube were inserted into



the rigid tube, but no air samples could be collected after 2 to 3 weeks, and at day 30 the silicone tube was removed from the rigid tube in the heap that was mixed after 30 days. A septum for gas sampling was located immediately after the diaphragm pump, continuously circulating air through the tubes during an experiment. Four samples of 55 ml were taken at each sample collection with syringes. The gas samples were transferred to 5 ml glass tubes fitted with butyl rubber septa. When injecting the samples into the glass tubes, a needle was inserted through the rubber seal and the tubes were flushed with 45 ml of the gas in the syringe, after flushing the tube the 15 ml remaining in the syringe were injected after removing the needle penetrating the septum (Petersen *et al.*, 1998).

### **Dynamic chamber**

The dynamic chamber consists of a mobile chamber covering the storage during measurements, a ventilator for suction of air through the chamber, and equipment for measurements of gas, temperature and air velocity. A field lab placed close to the experimental area provided the supply of electricity (340 Volts) to the ventilators and instruments for measurement of gas emission.

The three movable chambers on wheels had the dimensions, height 1.6 m, width 2 m and length 4 m. The chamber was made of waterproof plywood and mounted on a metal frame, with only one gable closed by plywood, the other end being open for facilitating the chambers to be moved over the heaps, and connected to a stationary gable placed at the end of the sealed surface. The gable on the chambers had an opening for incoming air. A steel tube (L:2 m, D:0.40 m) with a ventilator was connected to the stationary gable. A rectangular metal frame was mounted on the sealed surface perpendicularly to the stationary gable. The dimensions (length: 4 m, width: 2 m) of the frame allowed it to fit closely with the chambers when mounted. Air was drawn through the chamber by the ventilator enabling measurements of the flux of gases to and from the chamber. Before a measurement, the chambers were moved over the dung heap and fixed to the stationary gable.

Air flow through the dynamic chamber was measured with cup anemometers in the steel pipe, the air flow rates could be adjusted from the field-laboratory. Air temperature and the temperature in the dung heap (40 cm) was measured with PT100 and thermocouple sensors (Kontram A/S, DK-Copenhagen). The sensors were connected to a datalogger (Datataker DT200, Data Electronics LTD, Australia).

When measuring emissions of  $\text{NH}_3$  air speed was adjusted to  $3 \text{ m s}^{-1}$ , the air speed was adjusted to  $1.2 \text{ m s}^{-1}$  for measurements of  $\text{N}_2\text{O}$ ,  $\text{CH}_4$  and  $\text{CO}_2$  emissions. Ammonia was determined with active denuders. For analysis of  $\text{CH}_4$ ,  $\text{N}_2\text{O}$  and  $\text{CO}_2$  four gas samples of 55 ml were taken with syringes both at the inlet of the chamber, and from inside the steel tube 30 cm from the gable at each measuring occasion. The samples were stored as described above for gas samples taken from the dung

heap. The emission was calculated as the difference in the flux of gases of the incoming and outgoing gases.

## Gas Analysis

*Ammonia* : The concentration of ammonia in the air from the background and from the dynamic chambers was determined by active denuders (Ferm, 1979). An active denuder consists of a glass tube (length 500 mm, inner diameter 7 mm) coated on the inside with oxalic acid, through which air was drawn at a fixed air flow. A diaphragm pump provided suction and a critical orifice adjusted the air flow through the denuder to exactly  $0.9 \text{ L min}^{-1}$ . All  $\text{NH}_3$  flowing into the tube is absorbed on the oxalic acid. After exposure, the amount of  $\text{NH}_3$  absorbed in the tubes were determined, by dissolving the coating in 5 ml water and analysing  $\text{NH}_3$  concentration using a QuickChem 4200 (Lachat Instruments WI, USA).

The performance of the active denuders were examined in two tests. In test one, air at 1.35-1.45 ppm  $\text{NH}_3$  (v/v) was drawn through the denuders at time intervals from 2-10 min. In test two,  $\text{NH}_3$  concentrations was varied from 4 to 23.5 ppm  $\text{NH}_3$  and the suction time was 10 min. In each test 4 extra tubes were not used for measurements and included as blanks. In each test, two tubes were connected in series to test absorption capacity, one tube was directed to the  $\text{NH}_3$  source and the other was directed towards surroundings, all measurements were replicated. A Brühl and Kjær fotoacoustic gas monitor (DK-Copenhagen) was used to give the  $\text{NH}_3$  concentration of the air through the test runs.

*Methane ( $\text{CH}_4$ )* , *Nitrous oxide ( $\text{N}_2\text{O}$ )* ,  *$\text{CO}_2$*  and  *$\text{O}_2$* : Nitrous oxide and  $\text{CH}_4$  was measured on a Hewlet Packard (4890, series II) gas chromatograph with a electron capture detector and a flame ionisation detector. It was equipped with a 8 ft x 1/8" column with poropak Q 80/100 for  $\text{N}_2\text{O}$ ,  $\text{N}_2$  was used as a carrier at  $30 \text{ ml min}^{-1}$  and temperatures of injection port, oven and detection were 320, 70 and  $150^\circ\text{C}$ . Methane was isolated with a 6 Ft x 1/8" column with poropak N, He was used as carrier gas and temperatures of injection port, oven and detection were 270, 70 and  $150^\circ\text{C}$ . Oxygen and  $\text{CO}_2$  were measured on a Varian 3700 gas chromatograph with thermal conductivity detector. It was equipped with a 2-m x 1/8" column with a Molecular Sieve was used to isolate  $\text{O}_2$  and a 1-m x 1/8" column with Poropak N for  $\text{CO}_2$ . The carrier gas was He at a flow rate of  $40 \text{ ml min}^{-1}$ , the temperatures of oven and detector were 30 and  $190^\circ\text{C}$ , respectively.

## Composition of manure

Before analysis the organic material was thawed to  $0^\circ\text{C}$  and the total sample of 2 L were finely chopped with a cutting machine. Representative subsamples of about 500 g of the chopped material was then cut into small pieces and from this material 100 g was taken for analysis. All manure samples were analysed for dry weight, ash content, total C, Kjeldahl N, TAN (Total Ammoniacal Nitrogen),  $\text{NO}_3^-$ , P and K.

TAN and  $\text{NO}_3^-$  in the solid manure was extracted in 1 M KCl for 30 min, filtered before analysis with a QuickChem 4200 flow injection analyser (Lachat Instr. Wisconsin, USA). Dry matter was determined after drying at 105°C for 24 h, and ash content at 550°C for 4 h. Total C was determined by dry combustion (Leco model 521-275), K by flame photometry (FLM3, radiometer) after dry ashing and solubilization in acid, and P was measured colorimetrically (Spectronic 1001, Braush & Lomb) after dry ashing and solubilization in acid and a colouring reaction with ammonium molybdate vanadate. Total nitrogen ( $N_{\text{total}}$ ) was analyzed using the Kjeldahl method and a Kjellfoss 16200 (Copenhagen, DK).

## Calculations

The precision of the active denuder was tested by comparing the amount of  $\text{NH}_3$  absorbed in the tubes ( $\text{NH}_{3,\text{flux}}$ ) and the flux of  $\text{NH}_3$  flowing through the tube during the exposure period calculated by the following equation :

$$\text{NH}_{3,\text{flux}} = (\text{NH}_3) \cdot F \cdot \Delta t$$

( $\text{NH}_3$ ) is the concentration ( $\text{NH}_3\text{-N mg m}^{-3}$ ) that was determined with the Brühl and Kjær monitor, airflow  $F$  ( $\text{m}^3 \text{ min}^{-1}$ ) and  $\Delta t$  (min) the exposure period. The  $\text{NH}_{3,\text{flux}}$  was calculated by subtracting the amount of  $\text{NH}_3$  in the blank tubes from the  $\text{NH}_3$  being absorbed in the tubes during exposure.

The average  $\text{NH}_3$  concentration ( $C$ ,  $\mu\text{g NH}_3\text{-N m}^{-3}$ ) in the air measured by the tubes was calculated by the following equation :

$$C = (C_1 + C_2 - 2C_4) \cdot V / (F \cdot \Delta t)$$

where  $C_1$  and  $C_2$  are the concentrations of  $\text{NH}_4^+$  ( $\mu\text{g NH}_4\text{-N L}^{-1}$ ) in leachate from the two exposed tubes,  $C_4$  the average concentration of  $\text{NH}_4^+$  ( $\mu\text{g NH}_4\text{-N L}^{-1}$ ) in leachate from the four blank tubes,  $V$  is the volume of water used to dissolve the  $\text{NH}_4^+$  sorbed in the tubes (0.005 l),  $F$  is the air flow through the tubes ( $0.0009 \text{ m}^3 \text{ min}^{-1}$ ),  $\Delta t$  is the time (min) between the start and conclusion of the measurement.

## 3. Results and discussion

### Test of denuders

The active denuder was developed for measuring  $\text{NH}_3$  at ambient concentrations (Ferm, 1979). The capacity of the denuders for determining  $\text{NH}_3$  at high concentrations was therefore tested. The time of suction through the denuder at constant concentration of  $\text{NH}_3$  was examined first, showing the precision of the denuders increased by increasing the time of suction (Fig. 1A). In the second test a suction time of 10 minutes was therefore chosen, and the concentrations was varied (Fig 1B). In this test the amount of  $\text{NH}_3$  absorbed was highly correlated to the

amount of  $\text{NH}_3$  flowing into the tube, the correlation coefficient was 0.98 and coefficient of inclination 1 ( $P=5\%$ ). No increase of ammonia in the second tube

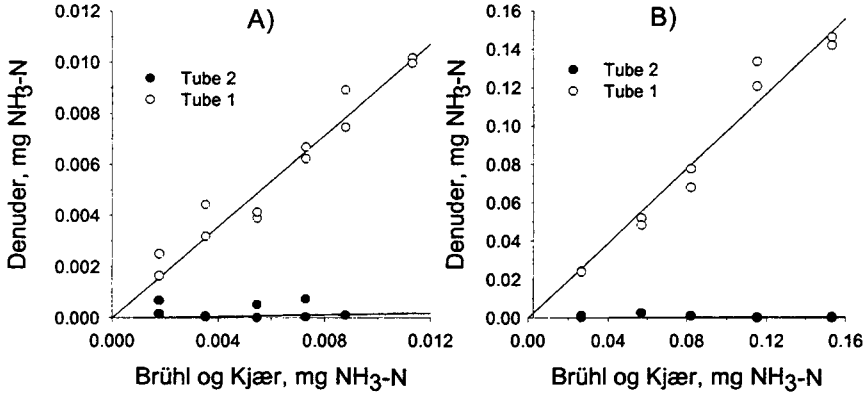

**Figure 1**

*Amount of  $\text{NH}_3$  absorbed in the denuder related to the amount of  $\text{NH}_3$  being sucked into the denuder calculated from measurements of concentrations by Brühl and Kjær fotoacoustic ammonia monitor, flow rate and period of suction. A. 1.35 ppm for 2 to 12 minutes and B) 4 - 24 ppm in 10 minutes.*

could be determined, indicating that the ammonia in the air was absorbed in the first tube at  $\text{NH}_3$  concentrations up to 24 ppm, at suction periods of 10 minutes and air flow rate of 0.9 l per minute. The tubes are superior to acid traps (Ryden and McNeill, 1984) when measuring  $\text{NH}_3$  concentrations for short periods, and are easy to handle because they can be stored for long periods both before and after exposure (Sommer *et al.* 1996).

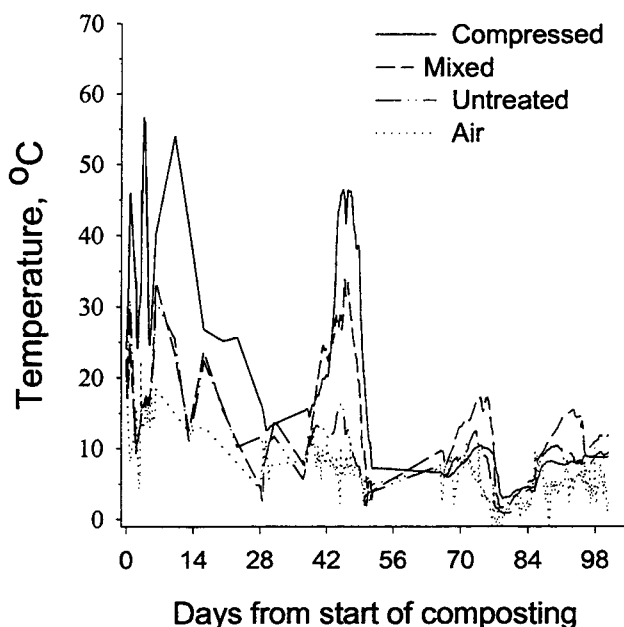

*Figure 2*  
 Air temperature and temperature N2O in a heap of deep litter, compressed, mixed after 30 days and untreated.

### Temperature and gas concentrations in the compost

At initiation of the experiments wind speeds were high. Therefore the temperature only increased to 20-30°C in the heaps that were not compressed and to 50-60°C in the compressed heap (Fig. 2). The temperature variation measured during the first week was related to changes in wind speed and declined at wind speeds above 15 ms<sup>-1</sup>. After 14 days the temperature declined. Few days after establishing the heap CO<sub>2</sub> concentrations in the compressed heap increased considerably, the variation in concentrations reflected changes in temperature (Fig. 3). Temperature and CO<sub>2</sub> concentrations will be related, because photosynthesis processes are negligible in compost and CO<sub>2</sub> therefore can be regarded as a parameter for microbial activity (Knuth, 1969). After a few weeks no gas could be sampled from inside the heaps. Therefore the sampler in the heap being mixed were changed at mixing. Throughout the experiments oxygen concentrations inside the heaps were near similar to the concentration in the ambient air. After mixing both the temperature and CO<sub>2</sub> concentration increased in the mixed heap, but also in the compressed heap an increase was measured (Fig. 2 and 3). This increase is probably related to growth of actinomyces and fungi's after the temperature decline, the fungi's using cellulose and hemmicellose as substrate (Hellman *et al.*, 1997). After 50 days the temperature in the compressed and mixed heap declined to ambient temperature and CO<sub>2</sub> in the mixed heap declined to ambient concentrations.

Nitrous oxide is a by-product of nitrification and denitrification and therefore an indicator of these processes (Hellman *et al.*, 1997). The high  $N_2O$  concentration initially may be an indicator of denitrification of  $NO_3$  present in the deep litter at initiation of the experiment (Fig. 3). Through the period with high temperature  $N_2O$  concentration was low because the number of nitrificants are reduced at high temperatures. After the decline in temperature the  $N_2O$  concentrations increased for a period in the compressed heap and the heap that later was mixed.  $N_2O$  increased again, when the heap was mixed probably because mixing increased composting and thereby created hot spots with low  $O_2$  concentration. Methane were only measured for a period from 30 to 80 days after initiation of the experiment, and in this period no significant increase in  $CH_4$  were determined. Nitrous oxide and  $CH_4$  concentrations were low compared to those measured in the studies of Petersen *et al.* (1998) and Sibbesen and Lind (1993), the open structure of the deep litter probably has facilitated a high convection of air through the organic material and thus reduced  $N_2O$  formation and methanogenesis or induced  $CH_4$  oxidation.

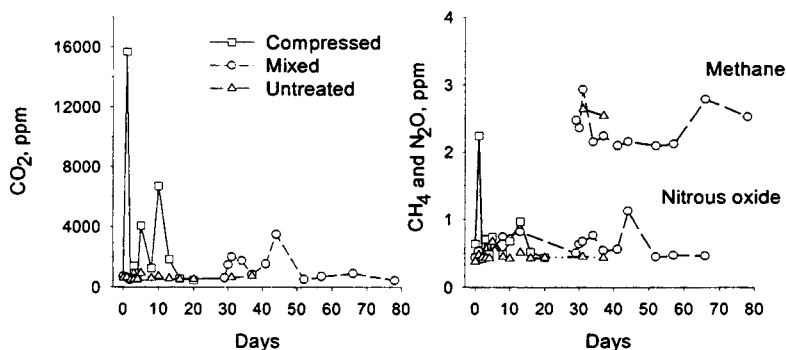

Figure 3.  
Concentration of  $CO_2$ ,  $CH_4$  and  $N_2O$  in a heap of deep litter, compressed, mixed after 30 days and untreated.

### Emission of gases

Emission of  $CO_2$  were high immediately after establishing the heaps and in the period from 30 to 40 days of composting. Emission of 2 to 3 kg  $CO_2$ -C  $ton^{-1}$  per day were determined during these periods (Fig. 4). In total  $CO_2$  emissions were 33 kg C, 20 kg C and 17 kg C from the litter being mixed after 30 days, compressed deep litter and untreated deep litter. The emission of  $CO_2$  was significant and reduced the content of C in the compost heaps with 10-19% (Table 2).

	Ammonia		Carbon dioxide		Nitrous oxide	
	kg N ton <sup>-1</sup>	pct. of N <sub>tot</sub>	kg C ton <sup>-1</sup>	pct. of C	g N ton <sup>-1</sup>	pct. of N <sub>tot</sub>
Compressed	0.23	3.0	19.7	12	0.17	0.0002
Untreated	0.1	1.2	17.1	10	0.388	0.0005
Mixed	0.22	2.6	32.9	19	0.04	0.00005

*Table 2.*  
*Cumulated emission of ammonia carbon dioxide and nitrous oxide*

The highest emission of N<sub>2</sub>O were 10 g N ton<sup>-1</sup> per day (2-3 g N m<sup>-2</sup> per day) were determined from day 10 to 15. In the study of Petersen *et al.* (1998) the highest emissions were observed from 40-50 days after initiation of the experiment, the difference in emission pattern may reflect that the temperature in the experiment of Petersen *et al.* (1998) was high for a longer period than in the present. The emission were low compared to emissions determined by Sibbesen and Lind (1993) and Petersen *et al.* (1998), and the cumulated emission of N<sub>2</sub>O did not cause significant losses of N from the compost (Table 2)

Significant CH<sub>4</sub> emission from the compressed and untreated litter were only observed from 30 to 40 days because data was missing from the first period of the measurements. The highest CH<sub>4</sub> emissions measured was 40 g CH<sub>4</sub>-C ton<sup>-1</sup> per day or approximately 15 g CH<sub>4</sub>-C m<sup>-2</sup> per day, which is similar to the emissions determined by Husted (1994). Cumulated emission of CH<sub>4</sub> were not calculated because data were missing.

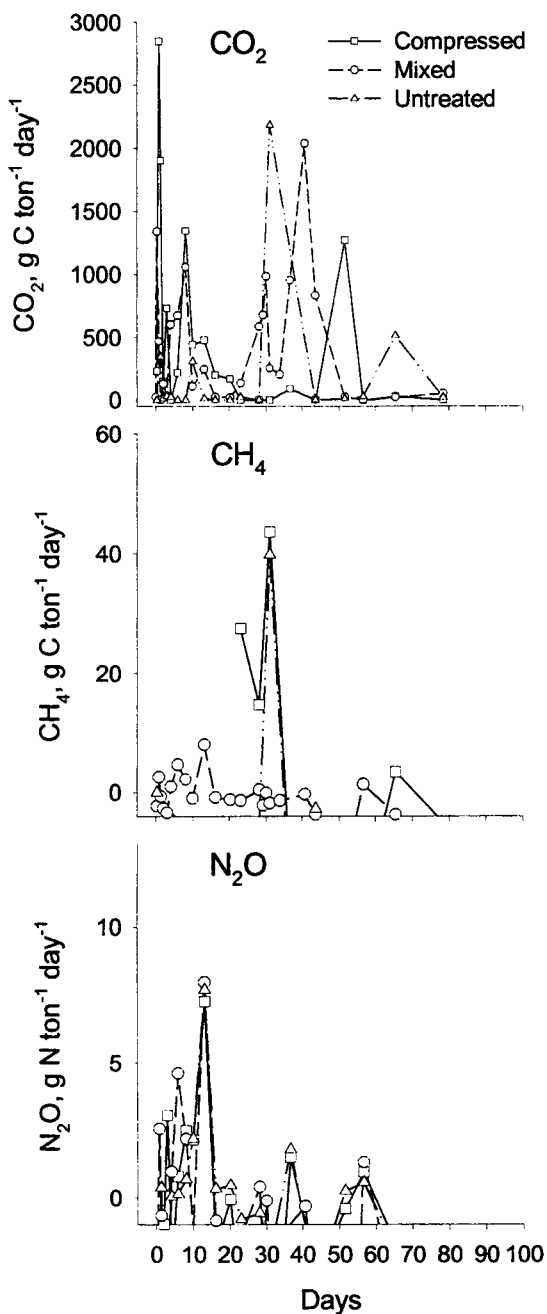

**Figure 4**  
*Emission of CO<sub>2</sub>, CH<sub>4</sub> and N<sub>2</sub>O in a heap of deep litter, compressed, mixed after 30 days and untreated*



Ammonia was only emitted from the dung heaps during the first 10 days after establishment, and also 2 to 3 days after turning of the heap being mixed (Fig. 5). In the study of  $\text{NH}_3$  volatilisation from solid cattle manure Petersen *et al.* (1998) observed a similar pattern in emission, but the emissions were four times higher due to higher concentrations of TAN in cattle solid manure than in deep litter. In the untreated litter with low temperature during the first five days volatilisation of  $\text{NH}_3$  was also low, indicating that nitrogen losses can be reduced by a treatment reducing the increase in temperature after storage of deep litter. The accumulated  $\text{NH}_3$  volatilisation from the compacted and mixed heaps was similar (Table 2). In this study ammonia volatilization during composting was low compared to losses measured by Petersen *et al.* (1998). The low  $\text{NH}_3$  emission is probably due to transformation of nitrogen in the animal house before storage and a high C:N ratio of the deep litter (=21).

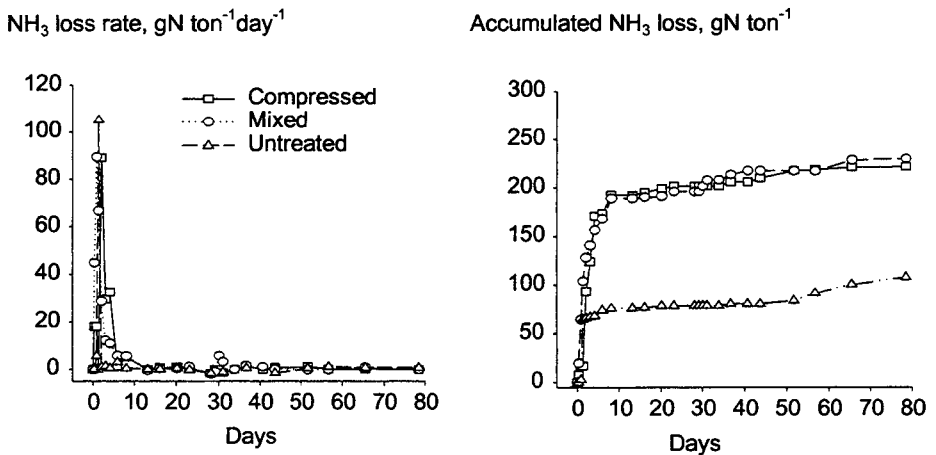

Fig 5.

Ammonia loss rate and accumulated ammonia volatilization from heaps of composting deep litter, compressed to double density, mixed after 30 days and untreated.

#### 4. References

- Ferm. M.** 1979. Method for determination of atmospheric ammonia. *Atmos. Environ.* 13, 1385-1393.
- Hellmann. B., Zelles. L., Palojärvi. A. and Bai. Q.** 1997. Emission of climate-relevant trace gases and succession of microbial communities during open-windrow composting. *Appl. Environ. Microbiol.* 63, 10111-10118.
- Husted. S.** 1994. Seasonal variation in methane emission from stored slurry and solid manures. *J. Environ. Qual.* 23, 585-592.

**Knuth. K.** 1969. Nitrogen-cycle ecology of solid waste composting. *Dev. Ind. Microbiol.* 11, 387-395.

**Martin. O. and Dewes. T.** 1992. Loss of nitrogenous compounds during composting of animal wastes. *Biores. Tech.* 42, 103-111.

**Petersen. S.O., Lind. A.-M. and Sommer. S.G.** 1998. Nitrogen and organic matter losses during storage of cattle and pig manure. *J. Agric. Sci. Camb.* 130, 69-79.

**Ryden. H.C. and McNeill. J.E.** 1984. Application of the micrometeorological mass balance method to the determination of ammonia loss from a grazed sward. *J.Sci. Food Agric.* 35, 1297-1310.

**Sibbesen. E. and Lind. A.M.** 1993. Loss of nitrous oxide from animal manure in dungheaps. *Acta. Agric. Acand. Sect. B, Soil Plant Sci.* 43, 16-20.

**Sommer. S.G., Sibbesen. E., Nielsen. T., Schjørring. J.K. and Olesen. J.E.** 1996. A passive flux sampler for measuring ammonia volatilization from manure storage facilities. *J. Environ. Qual.* 25, 241-247.

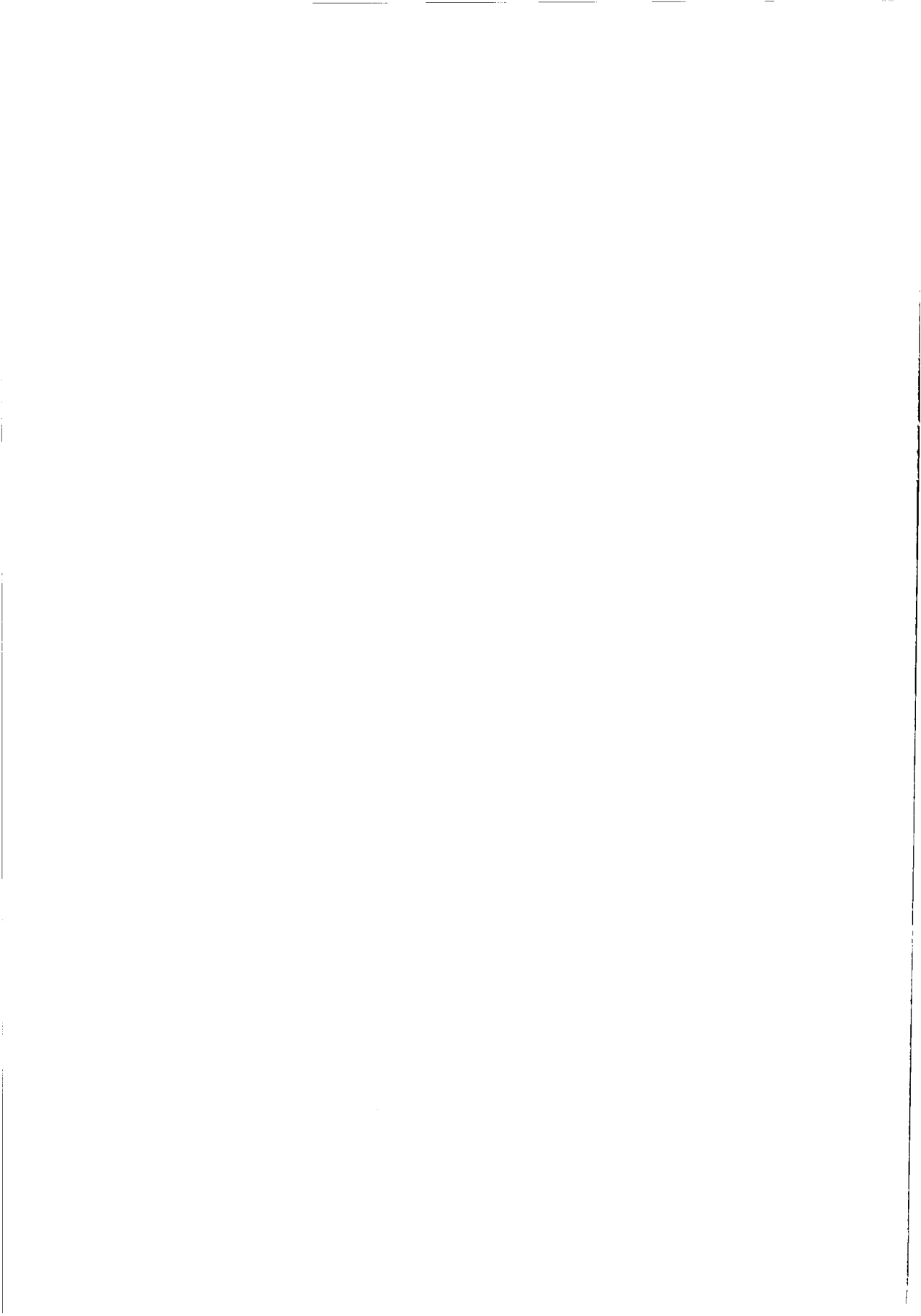

# Composting of organic wastes as a strategy for producing high quality organic fertilizers

*Compostage des déchets organiques  
pour la production d'engrais organiques de qualité.*

**M.P. Bernal, J. Cegarra, A. Roig, M.A. Sánchez-Monedero and C. Paredes**

Department of Soil and Water Conservation and Organic Waste Management.

Centro de Edafología y Biología Aplicada del Segura.

CSIC. P.O. Box 4195, 30080 Murcia, Spain.

E-mail : pbernal@natura.cebas.csic.es

## Abstract

*Composting is considered as a suitable way of recycling organic wastes in agriculture compatible with the environment. However, in order to obtain a final product with high value as fertilizer, the composting process should be performed adequately. Composting of organic wastes rich in easily biodegradable nitrogen compounds leads to the formation, accumulation and subsequent loss of ammonia through volatilization, mostly during the thermophilic phase of the process, where high temperatures, high ammonium concentration and pH concur. The use of a suitable bulking agent together with the Rutgers static pile composting system have been demonstrated to be useful tools for reducing and controlling such losses, obtaining a final compost rich in nitrogen.*

*A proper composting process procedure may ensure the absence of phytotoxic compounds and a sufficient maturity degree in the final compost. Immature compost can negatively affect the plant growth and nutrient supply. Studies of nitrogen mineralization revealed that immature or insufficiently stabilized compost can lead to nitrogen immobilization in soil and nitrogen deficiency in plants. The extension and proportion of nitrogen mineralization depended on the degree of compost stabilization. Therefore, the composting of organic wastes to obtain good quality composts, useful as organic fertilizers, requires a correct control of the process in order to minimize the nitrogen losses and to ensure a good degree of compost maturity.*

Key-words : composting, compost maturity, nitrogen mineralization, organic fertilizer, organic wastes.

## Résumé

Le compostage est considéré comme une méthode très appropriée pour le recyclage des déchets organiques dans l'agriculture d'une manière compatible avec l'environnement. Cependant, le processus de compostage doit être accompli d'une manière adéquate si l'on veut obtenir un produit final à haute valeur fertilisante. Le

compostage des déchets organiques riches en composés azotés facilement biodégradables conduit à la formation et l'accumulation, puis à la perte d'ammoniac par volatilisation, principalement pendant la phase thermophile, dans laquelle on obtient des températures et niveaux de pH élevés ainsi qu'une grande concentration en ammonium. L'utilisation d'un agent structurant avec le système de compostage « Rutgers » en tas statique a démontré leur efficacité pour réduire et contrôler une telle perte, en obtenant ainsi un compost riche en azote.

Par ailleurs, un processus de compostage approprié peut assurer l'absence de composés phytotoxiques et un degré de maturité suffisant dans le produit final. Un compost immature peut affecter négativement le taux de croissance des plantes ainsi que la disponibilité en éléments nutritifs. L'étude de la minéralisation de l'azote a révélé que l'emploi de compost insuffisamment stabilisé peut conduire à l'immobilisation de l'azote dans le sol et à la carence en azote des plantes. L'étendue et le taux de la minéralisation de l'azote sont reliés au taux de stabilisation du compost. Par conséquent, le compostage de déchets organiques pour la production de composts de bonne qualité, utilisables comme engrais organiques, exige un contrôle correct du processus pour minimiser les pertes d'azote et assurer une bonne maturité du compost.

**Mots-clés** : compostage, maturité du compost, minéralisation de l'azote, engrais organiques, déchets organiques.

## 1. Introduction

The composting of organic wastes is a biooxidative process involving the mineralization and partial humification of the organic matter, leading to a stabilized final product. During the first phase of the process the simple organic carbon compounds are easily mineralized and metabolized by the microorganisms, producing  $\text{CO}_2$ ,  $\text{NH}_3$ ,  $\text{H}_2\text{O}$ , organic acids and heat. The accumulation of this heat raises the temperature of the pile.

The composting of organic wastes rich in easily biodegradable nitrogen compounds, such as sewage sludge, leads to the formation, accumulation, and subsequent loss of nitrogen, mostly through ammonia volatilization. Sewage sludge is often composted before it is added to soil because this process eliminates the risk of disseminating pathogenic organisms and produces an aesthetically acceptable product for use in agriculture. However, during the first phase of composting, the combination of high temperatures, high ammonium concentration and high pH levels may lead to substantial losses of ammonia (Witter and Lopez-Real 1987), decreasing the value of the material as an N fertilizer. The addition of carbon sources to wastes rich in inorganic-N results in its partial incorporation into the organic fractions or its immobilization to form such fractions (Van Faasen and Van Dijk, 1979). It is possible to reduce ammonia losses during the composting of organic wastes with a high

nitrogen concentration by adding an adequate bulking agent which provides organic carbon to the mixture (Sánchez-Monedero et al., 1996a). The loss of nitrogen from the compost piles also depends on the diffusion of  $\text{NH}_3$  through the pile into the atmosphere, and frequent turning of the pile facilitates this  $\text{NH}_3$ -volatilization (De Bertoldi et al., 1982). The Rutgers static pile composting system maintains a temperature ceiling in the pile, providing a high decomposition rate through the on-demand removal of heat by ventilation, since high temperatures inhibit and slow down decomposition due to a reduction of microbial activity (Finstein & Miller, 1985). This system has been shown to be a good method to reduce N-losses through  $\text{NH}_3$ -volatilization and, hence, for producing a N rich compost (Sánchez-Monedero et al, 1996a) with high concentrations of  $\text{NO}_3^-$ -N and total-N.

Once a compost with high nitrogen concentration has been obtained, it is important to know the fraction available to plants. According to Castellanos and Pratt (1981), the composting of animal manures reduces the value of the manure as a N fertilizer because the compost provides only half the available-N compared with non-composted manures. Bernal et al. (1998a) and Beloso et al. (1993) concluded that immature composts can promote N-immobilization in the soil, as they contain high concentrations of easily degradable C-compounds as a result of their incomplete stabilization.

Therefore, the aims of this work were twofold. The first was to study the evolution of the main parameters during the composting of a sewage sludge with an appropriate bulking agent in order to obtain a nitrogen rich compost; and the second was to evaluate the resulting compost value as a N fertilizer

## **2. Materials and methods**

### **Composting performance**

About 1500 kg of a mixture prepared with 46.5 % sewage sludge and 53.5 % cotton waste (fresh weight) was composted in a pilot plant by the Rutgers static pile composting system. The air was blown from the base of the pile through the holes of three PVC tubes of 3 m length and 12 cm diameter. The timer was set for 30 s ventilation every 15 min. and the ceiling temperature for continuously blown air was 55 °C. The biooxidative phase of composting (active phase) was considered completed when the temperature of the pile was stable and near to that of the atmosphere, this stage being reached after 49 days. The air-blowing was then stopped to allow the compost to mature over a period of two months. The pile was sampled weekly during the active phase and after the maturation period. Each sample was divided into two parts, one of which was immediately frozen and kept for  $\text{NH}_4^+$ -N and  $\text{NO}_3^-$ -N analysis, while the other subsample was air-dried and ground to 0.02 mm for analysis and for a pot experiment.

## Analytical methods

The composting samples were analyzed for electrical conductivity and pH in a water soluble extract 1:10 (w/v); organic matter (OM) by loss-on-ignition at 430°C during 24 hours (Navarro et al., 1993); total nitrogen and organic carbon were determined by automatic microanalysis (Navarro et al., 1991), as were the water soluble organic carbon ( $C_w$ ), the 0.1 M NaOH extractable C and fulvic acid C after precipitation of the humic acids at pH 2.0 (Sánchez-Monedero et al., 1996b). The humic acid C was calculated by subtraction of the fulvic acid C from the extractable C.  $\text{NH}_4^+$ -N was extracted with 2M KCl from the frozen subsample and determined by a colorimetric method based on Berthelot's reaction (Sommer et al., 1992), adding sodium citrate to complex divalent cations;  $\text{NO}_3^-$ -N was determined by ion chromatography HPLC in the water extract. The cation exchange capacity was determined with  $\text{BaCl}_2$ -triethanolamine (Lax et al., 1986). Total P, K and micronutrients were determined after  $\text{HNO}_3/\text{HClO}_4$  digestion, P by the colorimetric method as a molybdovanadate phosphoric acid, K by flame photometry and micronutrients by atomic absorption spectrophotometry. All chemical analyses were made in duplicate. The germination index (GI) was calculated using seeds of *Lepidium sativum* L. (Zucconi et al., 1981).

## Greenhouse experiment

The effect of compost maturity on crop yield and its effectiveness as organic nitrogen fertilizer was studied in a greenhouse pot experiment. Four samples were selected at different stages of the composting process: (i) the initial non-decomposed mixture at day 0 (I), (ii) the thermophilic phase at day 21 (T), (iii) the end of the active phase at day 49 (A) and (iv) the mature compost at day 105 (M). The I, T, A and M composting samples were added at a rate of 2 % ( $48 \text{ t ha}^{-1}$ ) to a calcareous silt loam soil, classified as a Xerollic Calciorthid (American Soil Taxonomy). Its main characteristics were: pH 7.8, electrical conductivity 0.028 S/m, organic matter 1.72 %, total-N 1.1 g/kg, available-P 9.0 mg/kg, cation exchange capacity 119.0 mmol/kg, exchangeable-K 7.2 mmol/kg, and water holding capacity 33.5 %. The soil was passed through a 4 mm screen to remove large particles. Pots of 500 g capacity were used for the experiment. Five treatments were run: soil without any fertilization (S) to estimate the soil's fertility, soil fertilized with 20-20-20 N-P-K mineral fertilizer (0.135 g/pot/month;  $13 \text{ g m}^{-2}$  per month) (S+F), soil amended with the initial composting sample (S+I), soil amended with the sample at the thermophilic phase (S+T), soil amended with the sample at the end of the active phase of composting (S+A) and soil amended with the mature compost (S+M). The pots were immediately sown with ryegrass (*Lolium perenne* L.) at a rate of 0.5 g per pot (265 seeds/pot), which was equivalent to  $47.6 \text{ g m}^{-2}$ , over a 0.5 cm sand layer to facilitate seed germination. Another two sets of S, S+I and S+M treatments were incubated at 28 °C for 21 and 49 days before sowing. Each treatment was replicated four times, giving a total of 20 pots without incubation, and 12 pots for the 21 and 49 day incubations. The moisture of the soils was adjusted to 60 % of their water holding capacity with deionized water. The pots were watered daily with deionized water and the ryegrass plants were harvested three times at 28 day intervals. The plant materials were weighed, dried at 60 °C and ground to 0.5 mm

for analysis. The total-N concentration of the plant material was analyzed by a CNS automatic microanalyzer. The N uptake of plants was calculated from the dry weight and N concentration of the plants. Analysis of variance and Duncan's multiple range test were used to determine differences in yield and composition of plants between treatments.

### 3. Results and discussion

#### Evolution of the main parameters during composting

The organic matter and organic C concentrations of the waste mixture decreased during composting (Table 1), pointing to degradation of the organic materials during the process. This organic matter degradation led to an increase in electrical conductivity, and so the production of inorganic compounds. The  $N_t$  also increased because of the concentration effect caused by the strong degradation of the labile organic C compounds, which reduced the weight of the composting mass. The concentration of  $N_t$  usually increases during composting when volatile solids (organic matter) loss is greater than the loss of  $NH_3$  (Witter and Lopez-Real, 1987). The N-lost from the piles during composting were determined from the initial and final ash ( $X_1$  and  $X_2$ ) and nitrogen ( $N_1$  and  $N_2$ ) concentrations. The total N losses amounted to only 9 %, which is very low in comparison with the values found by Witter and Lopez-Real (1987) (50 % N) during sewage sludge composting. More than 60 % of N can be lost during city refuse composting (Sánchez-Monedero, 1996a), while the N losses during sewage sludge composting can range from almost zero to 25 %, depending on the bulking agent used (Paredes et al., 1996). This means, therefore that the composting was properly performed because of the adequate bulking agent used and the system (Rutgers static pile), both of which were relevant factors in keeping N losses to a minimum. The mature compost had a  $N_t$  concentration higher than  $10 \text{ mg kg}^{-1}$ , which is the concentration required for composts according to Spanish legislation, and can therefore be considered as an organic fertilizer. The  $N_t$  concentration was higher than the  $4.5 - 28.2 \text{ g kg}^{-1}$  found for city refuse, sewage sludge and animal manure composts (Iglesias-Jimenez et al., 1986; Gallardo-Lara and Nogales, 1987; Warman and Termeer, 1996). The C/N ratio decreased to 9.4 during the composting process, which is below the 12 normally accepted as indicating a good degree of compost maturity (Iglesias-Jimenez and Perez-García, 1992; Bernal et al., 1998b).



Samples (days)	pH	EC (S m <sup>-1</sup> )	OM (%)	C <sub>org</sub> (g kg <sup>-1</sup> )	N <sub>t</sub> (g kg <sup>-1</sup> )	C/N	NH <sub>4</sub> <sup>+</sup> -N (mg kg <sup>-1</sup> )	NO <sub>3</sub> <sup>-</sup> -N (mg kg <sup>-1</sup> )
0	7.6	0.39	81.5	438.6	21.9	21.1	1424	< 1
7	7.8	0.39	75.7	407.9	23.4	18.2	1038	nd.
14	7.9	0.45	74.1	404.7	29.9	14.0	1263	nd.
21	8.2	0.43	71.3	398.2	31.5	14.2	3406	45
28	8.2	0.45	67.6	382.0	33.4	12.4	2530	30
35	8.2	0.47	64.1	370.3	33.3	11.4	907	470
42	8.1	0.51	64.9	364.6	32.5	12.5	807	1000
49	8.0	0.50	64.9	359.8	36.5	9.9	1081	1170
105	7.3	0.67	64.8	355.5	37.9	9.4	437	4884

Table 1.

*Evolution of the main parameters during composting.*

The initial NH<sub>4</sub><sup>+</sup>-N concentration was high and increased during the thermophilic phase as a result of organic-N mineralization, which also caused a rise in the pH values. After this phase, the NH<sub>4</sub><sup>+</sup>-N concentration decreased to a final value close to 0.04 %, which is the maximum limit suggested by Zucconi and de Bertoldi (1987) and Bernal et al. (1998b) for a mature compost. Parallel to this fall in the NH<sub>4</sub><sup>+</sup>-N concentration, the NO<sub>3</sub><sup>-</sup>-N levels increased due to nitrification, while the pH value decreased, due to the protons released by this process. There was hardly any nitrification during the thermophilic phase, because temperatures greater than 40 °C inhibit the activity and growth of nitrifiers. An NH<sub>4</sub><sup>+</sup>/NO<sub>3</sub><sup>-</sup> ratio of lower than 1 was found at the end of the active phase (49 days) and after the maturation period (105 days), the value reached at the latter time (0.09) indicating that this compost had reached a good degree of maturity (Bernal et al., 1998b).

The C<sub>W</sub> and C<sub>FA</sub> concentrations fell during composting (Table 2) because both fractions had a high proportion of easily biodegradable organic compounds (sugars, amino acids, peptides, etc.). The C<sub>W</sub> concentration in the mature compost was below the limit of 1.7 % established by Bernal et al. (1998b) as representing a good maturity degree. The C<sub>W</sub>/N<sub>org</sub> ratio decreased during composting to a value well below the established limits for mature composts (0.7 by Hue and Liu, 1995; 0.55 by Bernal et al., 1998b). The humic acid-like fraction, C<sub>HA</sub>/C<sub>FA</sub> ratio and humification index increased during composting, demonstrating the humification and polymerization of the organic matter which took place. This organic matter humification process led to an increased cation exchange capacity during the biooxidative and maturation phases. The values reached were higher than the 60 and 67 cmol kg<sup>-1</sup> described by Harada and Inoko (1980) and Iglesias-Jimenez and Perez-García (1992), respectively, as being the minimum values required to ensure a sufficient degree of maturity in city refuse composts. The germination index exceeded 50 %, which indicated the lack of phytotoxicity (Zucconi et al., 1981).

Samples (days)	C <sub>w</sub> (%)	C <sub>w</sub> /N <sub>org</sub>	C <sub>F<sub>A</sub></sub> (%)	C <sub>H<sub>A</sub></sub> (%)	C <sub>H<sub>A</sub></sub> / C <sub>F<sub>A</sub></sub>	HI	CEC (cmol <sub>c</sub> kg <sup>-1</sup> )	GI (%)
0	2.27	1.17	3.75	7.18	1.91	16.4	53.5	77.8
7	2.02	0.90	5.07	6.47	1.28	15.8	67.4	n.d.
14	2.25	0.78	3.88	8.00	2.06	19.8	n.d.	n.d.
21	2.02	0.71	3.80	7.42	1.95	18.6	95.3	65.4
28	1.98	0.64	3.79	7.86	2.07	20.6	n.d.	n.d.
35	1.88	0.59	3.73	8.39	2.25	22.6	109.9	n.d.
42	1.74	0.61	3.32	7.93	2.39	21.7	n.d.	n.d.
49	2.26	0.64	3.11	7.75	2.49	21.5	100.7	71.1
105	1.12	0.34	2.57	7.90	3.07	22.2	124.4	69.4

n.d. not determined.

Table 2.

*Evolution of the organic matter during composting.*

### Greenhouse studies

The macro and micronutrient concentrations of the composting samples used as fertilizers are shown in Table 3. These materials were taken from the air-dried subsamples and, since most of the NH<sub>4</sub><sup>+</sup>-N was lost during drying, their NH<sub>4</sub><sup>+</sup>-N and, hence, N<sub>t</sub> concentrations were slightly different from the values presented in Table 1. The yield of ryegrass 28 days after emergence (first harvest) decreased from soil (S) to the soil amended with T (S+T) and with I (S+I) (Table 4). The results obtained in the soil treated with mineral fertilizer (S+F) were not statistically different from those of the S+A and S+M treatments but were greater than those of the S, S+I and S+T. When the S+I treatment was incubated for 21 days before sowing, the yield increased to values similar to those found in S, and the difference was not statistically significant. The best result with I was obtained in the treatment incubated for 49 days. Plants in the S+I and S+T treatments had the lowest N concentrations, which were statistically different from plants grown in S. This may indicate that the low yield in those treatments was due to N deficiency in plants. Twenty one days of incubation led to an increase in the N concentration of plants in S+I. Treatments with M compost led to the highest N concentration in plants, this mature compost containing a high proportion of available N in nitrate form (Table 3).

	I (0 days)	T (21 days)	A (49 days)	M (105 days)
N <sub>t</sub> (g kg <sup>-1</sup> )	20.8	28.3	35.4	37.9
NH <sub>4</sub> <sup>+</sup> -N (mg kg <sup>-1</sup> )	366	172	158	437
NO <sub>3</sub> <sup>-</sup> -N (mg kg <sup>-1</sup> )	<1	45	1170	4884
P (g kg <sup>-1</sup> )	2.2	4.1	6.6	7.1
K (g kg <sup>-1</sup> )	31.9	25.9	30.5	40.6
Na (g kg <sup>-1</sup> )	3.1	3.9	4.4	6.2
Ca (g kg <sup>-1</sup> )	28.4	n.d.	n.d.	64.8
Mg (g kg <sup>-1</sup> )	5.0	n.d.	n.d.	10.6
Fe (g kg <sup>-1</sup> )	1.5	1.8	1.8	3.8
Cu (mg kg <sup>-1</sup> )	20	25	38	38
Mn (mg kg <sup>-1</sup> )	111	147	164	220
Zn (mg kg <sup>-1</sup> )	112	94	118	213

Table 3.

*Macro and micronutrients of the composting samples used in the pot experiment.*

Treatments	First harvest		Second harvest		Third harvest	
	Yield (g/pot)	N (%)	Yield (g/pot)	N (%)	Yield (g/pot)	N (%)
S	4.10 de	3.58 e	1.59 e	1.85 de	0.73 f	1.59 d
S+F	5.54 c	4.49 d	4.19 bc	2.33 abc	3.50 a	2.41 a
S+I	1.75 f	2.49 fg	3.77 bcd	1.82 de	2.86 bc	1.65 cd
S+T	2.92 ef	2.40 g	2.94 d	2.01 cde	2.32 cd	1.72 cd
S+A	5.58 c	4.41 cd	3.55 ed	2.18 bcd	2.32 cd	1.64 cd
S+M	6.52 bc	5.30 ab	4.47 b	1.95 de	2.07 de	1.63 cd
S 21 days	3.34 de	4.61 cd	1.63 e	1.79 e	0.89 f	1.92 bc
S+I 21 days	3.90 de	3.62 e	3.13 d	1.69 e	2.38 bcd	1.98 bc
S+M 21 days	4.30 d	5.37 a	5.75 a	2.62 a	2.71 bc	2.05 abc
S 49 days	3.62 de	4.25 d	2.03 e	1.80 e	0.79 f	1.79 bcd
S+I 49 days	7.10 ab	2.96 f	2.97 d	1.83 de	1.71 e	2.20 ab
S+M 49 days	8.08 a	4.84 bc	4.00 bc	2.38 ab	1.66 e	1.77 bcd
ANOVA $P <$	0.001	0.001	0.001	0.001	0.001	0.05
LSD	1.22	0.52	0.77	0.37	0.48	0.45

LSD= least significant difference at  $P < 0.05$ .

*Table 4.*

*Yield (fresh weight) and nitrogen concentration of rye-grass in the three harvests.*

At the second harvest, the yield in S was very low due to the depletion of soil nutrients and the results were significantly different from those of the rest of the treatments, which showed similar values statistically, including S+I (Table 4). The plant yield in S+M was the highest of both harvests, although it was not statistically different from that obtained in S+F. The incubation time had no effect on the yield of the S+I treatment, and only a slight increase was observed in S+M after 21 days' incubation. The N concentration of plants was very similar in all treatments, and only the S+F in the non-incubated treatments and S+M with 21 and 49 days' incubation were significantly different from the rest. In general the results, including those for the treatment with mineral fertilizer, decreased from the first to the second harvest, which may be due to plant physiology rather than the effect of the compost.

The yield at the third harvest showed the same pattern as the second. The soil had the lowest results, which demonstrated the depletion of nutrients, while the best result was obtained with S+F. There were no statistically significant differences between the yield and N concentration of plants in any of the treatments using composts. The highest N concentration was recorded in plants from S+F, since the nutrients were added weekly throughout the experiment. Incubation slightly increased the N concentration although only the result from S+I with 49 days' incubation was significantly different from the non-incubated treatments.

The N efficiency of the composting samples and the mineral fertilizer was calculated by subtracting the N uptake of the soil from that recorded in the amended soil, and expressed as a percentage of N added to soil. The maximum N efficiency always occurred in the S+F treatment (Fig. 1), as the N it contained was directly available to plants. The N efficiency of sample I showed negative values after the three harvests in the non-incubated treatment, and after two harvests in the 21 days' incubation treatment, indicating that plants in S+I had lower amount of N available than those grown in the control soil. Sample I had  $\text{NH}_4^+\text{-N}$ , which is readily available to plants (Table 4), but it also had a high amount of easily decomposable organic C compounds (Bernal et al., 1998a). For this reason, the microorganisms attacking this fresh organic matter found a surplus of organic C with respect to organic N, which led to inorganic-N immobilization, and a competition between plant roots and microorganisms for inorganic-N may have occurred. When the S+I was incubated for 49 days before sowing, the N efficiency of I showed positive values after each harvest, which indicated that re-mineralization of the immobilized N had occurred and that inorganic-N had formed in the soil. Studies of N-mineralization in soil pointed to the immobilization of inorganic-N in sample I during most of the incubation period. Only 2.4 % of  $\text{N}_i$  was present in the forms of inorganic-N after 70 days, giving it a net N-immobilization of 4.3 %  $\text{N}_i$  (Bernal et al., 1998a).

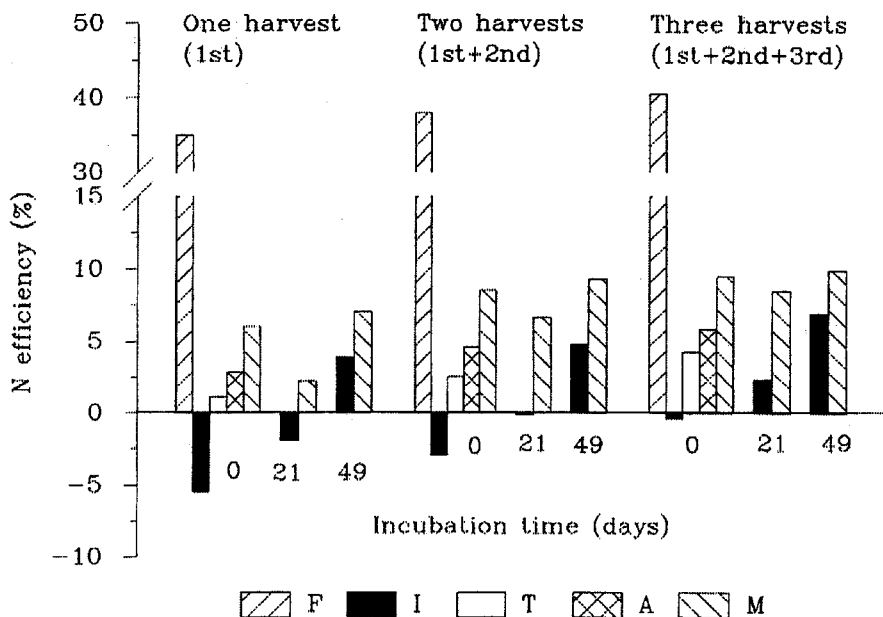

**Figure 1.** Nitrogen fertilizer efficiency of the materials used in the different treatments of the pot experiment. The figures referring to harvest are accumulative.

The N efficiency of composting samples increased as composting progressed (Fig. 1). The efficiency of T sample although greater than that of I was still very low, especially at the first harvest, pointing to  $\text{NH}_4^+$ -N immobilization in the soil as a consequence of low microbial stabilization. Substantial proportions of inorganic-N immobilization have been reported in soils treated with immature composts made from animal manure and sewage sludge (Beloso et al., 1993; Bernal et al., 1998a). Sims (1990) also found N-immobilization in a soil treated with 7-day old sewage sludge/city refuse composts, which diminished when one of them was mixed with a commercial mature compost.

The sample A had a higher N efficiency than I and T, but lower than the mature compost. The sample A had a lower  $\text{NO}_3^-$ -N concentration than the mature compost (Table 3), and the N mineralization studies also showed lower proportion of potentially mineralizable N (5.45 %  $\text{N}_t$  in A, 8.45 %  $\text{N}_t$  in M) and a slight initial N-immobilization in the soil, which only lasted only for 2 days (Bernal et al., 1998a). The immobilization was not strong enough to have any effect on plant growth, since the material had a sufficiently high concentration of inorganic-N for adequate plant nutrition, and it had reached a good degree of stability during the 49 days of composting. It had also a relevant proportion of mineralizable N (inorganic-N = 9 % of  $\text{N}_t$  after 70 days of incubation) giving it a net N-mineralization figure of 4.7 %  $\text{N}_t$  (Bernal et al., 1998a). The highest efficiency was found in the M sample, because it had the highest  $\text{NO}_3^-$ -N concentration and proportion of potentially mineralizable N. It was observed that the  $\text{NO}_3^-$ -N concentration of the compost increased during the maturation phase of composting (Table 1), and also this mature material had stabilized during the active and maturation phases of composting, and net N-mineralization occurred after its addition to soil. According to Bernal et al. (1998a), almost 20 % of  $\text{N}_t$  was present as inorganic-N in soil after 70 days of incubation, giving it a net N mineralization of 8 % of total-N. Both factors provided a high amount of readily available N for plants, and the greatest N uptake by plants.

#### 4. Conclusions

The composting of sewage sludge can provide a compost rich in N, if the process is properly performed, which can be used as an organic fertilizer. The use of a bulking agent, such as cotton waste, which supplies organic carbon to the microorganisms, together with the Rutgers static pile system are the main strategies for controlling and reducing N losses during composting. Two months of maturation after temperature has fallen are enough to ensure a good degree of compost maturity and a certain humification of its organic matter.

Maturation improves the short-term fertilizer N value of a compost because  $\text{NO}_3^-$ -N is formed during this phase and because of its potentially mineralizable N. A mature compost can, therefore, be considered as an organic N fertilizer. Its N mineralization rate should be taken into account for the balanced N fertilization of crops and it can

even be added to the soil when the crop is growing. The use in soil of non-decomposed organic waste mixtures or of wastes which have only been slightly transformed in the thermophilic phase of composting, requires a safety period of at least 49 days after addition and before sowing, to avoid plants suffering N deficiency and to ensure that the microbial N-immobilization phase has finished and inorganic-N is being produced by re-mineralization of the immobilized-N. This is necessary to obtain a good efficiency of its nitrogen. A compost which has undergone a biooxidative phase of composting but not a maturation phase, although it may cause slight N-immobilization immediately after its addition to soil, it is also valuable as a N fertilizer. It can have a similar effect on plant nutrition as an inorganic fertilizer, because its N will have been mineralized at a similar rate as that of a mature compost. However, its N fertilizer value is lower than that of the mature compost because the nitrification process occurs mainly during maturation. This increases the concentration of N available to plants in nitrate form.

## 5. References

- Beloso, M.C., Villar, M.C., Cabaneiro, A., Carballas, M., González-Prieto, S.J. & Carballas, T.** 1993. Carbon and nitrogen mineralization in an acid soil fertilized with composted urban refuses. *Biores. Technol.*, **45**, 123-129.
- Bernal, M.P., Navarro, A.F., Sánchez-Monedero, M.A., Roig, A. & Cegarra, J.** 1998a. Influence of sewage sludge compost stability and maturity on carbon and nitrogen mineralization in soil. *Soil Biol. Biochem.*, **30**, 305-313.
- Bernal, M.P., Paredes, C., Sánchez-Monedero, M.A. & Cegarra, J.** 1998b. Maturity and stability parameters of composts prepared with a wide range of organic wastes. *Biores. Technol.*, **63**, 91-99.
- Castellanos, J.Z. & Pratt, P.F.** 1981. Mineralization of manure nitrogen - correlation with laboratory indexes. *Soil Sci. Soc. Am. J.*, **45**, 354-357.
- De Bertoldi, M., Vallini, G., Pera, A. & Zucconi, F.** 1982. Comparison of three windrow composting system. *BioCycle*, **23**, 45-50.
- Finstein, M.S. & Miller, F.C.** 1985. Principles of composting leading to maximization of decomposition rate, odor control, and cost effectiveness. *In Composting of agricultural and other wastes*, ed. J.K.R. Gasser. Elsevier Applied Science Publ., Barking, Essex, pp. 13-26.
- Gallardo-Lara, F. & Nogales, R.** 1987. Effect of the application of town refuse compost on the soil-plant system: A review. *Biol. Wastes*, **19**, 35-62.
- Harada, Y. & Inoko, A.** 1980. Relationship between cation-exchange capacity and degree of maturity of city refuse composts. *Soil Sci. Plant Nutr.*, **26**, 353-362.

Hue, N.V. & Liu, J. 1995. Predicting compost stability. *Compost Sci. Utilization*, **3**, 8-15.

Iglesias-Jiménez, E. & Pérez-García, V. 1992. Determination of maturity indices for city refuse composts. *Agric. Ecosystems Environ.*, **38**, 331-343.

Iglesias-Jiménez, E., Pérez-García, V. & Fernández-Falcón, M. 1986. The agronomic value of the sewage sludge of Tenerife. Composting. *Agric. Wastes*, **17**, 119-130.

Lax, A., Roig, A. & Costa, F. 1986. A method for determining the cation-exchange capacity of organic materials. *Plant and Soil*, **94**, 349-355.

Navarro, A.F., Cegarra, J., Roig, A. & Bernal, M.P. 1991. An automatic microanalysis method for the determination of organic carbon in wastes. *Commun. Soil Sci. Plant Anal.*, **22**, 2137-2144.

Navarro, A.F., Cegarra, J., Roig, A. & García, D. 1993. Relationships between organic matter and carbon contents of organic wastes. *Biores. Technol.*, **44**, 203-207.

Paredes, C., Bernal, M.P., Cegarra, J., Roig, A. & Navarro, A.F. 1996. Nitrogen transformation during the composting of different organic wastes. In *Progress in Nitrogen Cycling Studies*. Eds O. van Cleemput, G. Hofman, A. Vermoesen. Kluwer Academic Publishers, Dordrecht, pp. 121-125.

Sánchez-Monedero, M.A., Bernal, M.P., Roig, A., Cegarra, J., García, D. 1996a. The effectiveness of the Rutgers system and the addition of bulking agent in reducing N-losses during composting. In *Progress in Nitrogen Cycling Studies*. Eds O. van Cleemput, G. Hofman, A. Vermoesen. Kluwer Academic Publishers, Dordrecht, pp. 133-139.

Sánchez-Monedero, M.A., Roig, A., Martínez-Pardo, C., Cegarra, J., Paredes, C. 1996b. A microanalysis method for determining total organic carbon in extracts of humic substances. Relationships between total organic carbon and oxidable carbon. *Biores. Technol.*, **57**, 291-295.

Sims, J.T. 1990. Nitrogen mineralization and elemental availability in soils amended with cocomposted sewage sludge. *J. Environ. Qual.*, **19**, 669-675.

Sommers, S.G., Kjellerup, V. & Kristjansen, O. 1992. Determination of total ammonium nitrogen in pig and cattle slurry: sample preparation and analysis. *Acta Agric. Scand.*, Section B **42**, 146-151.

**Van Faasen, H.G. & Van Dijk, H.** 1979. Nitrogen conversion during the composting of manure straw mixtures. In: *Straw Decay and its Effect of Disposal and Utilization*. Ed. E. Grossbard. John Wiley and Sons, New York. pp. 113-119.

**Warman, P.R. & Termeer, W.C.** 1996. Composting and evaluation of racetrack manure, grass clippings and sewage sludge. *Biores. Technol.*, **55**, 95-101.

**Witter, E. & Lopez-Real, J.M.** 1987. The potential of sewage sludge and composting in a nitrogen recycling strategy for agriculture. *Biol. Agric. Horticulture*, **5**, 1-23.

**Zucconi, F. & de Bertoldi, M.** 1987. Compost specifications for the production and characterization of compost from municipal solid waste. In *Compost: production, quality and use*, eds. M. de Bertoldi, M.P. Ferranti, P. L'Hermite, F. Zucconi. Elsevier Applied Science, Essex, pp. 30-50.

**Zucconi, F., Pera, A., Forte, M., de Bertoldi, M.** 1981. Evaluating toxicity of immature compost. *BioCycle*, **22**, 54-57.



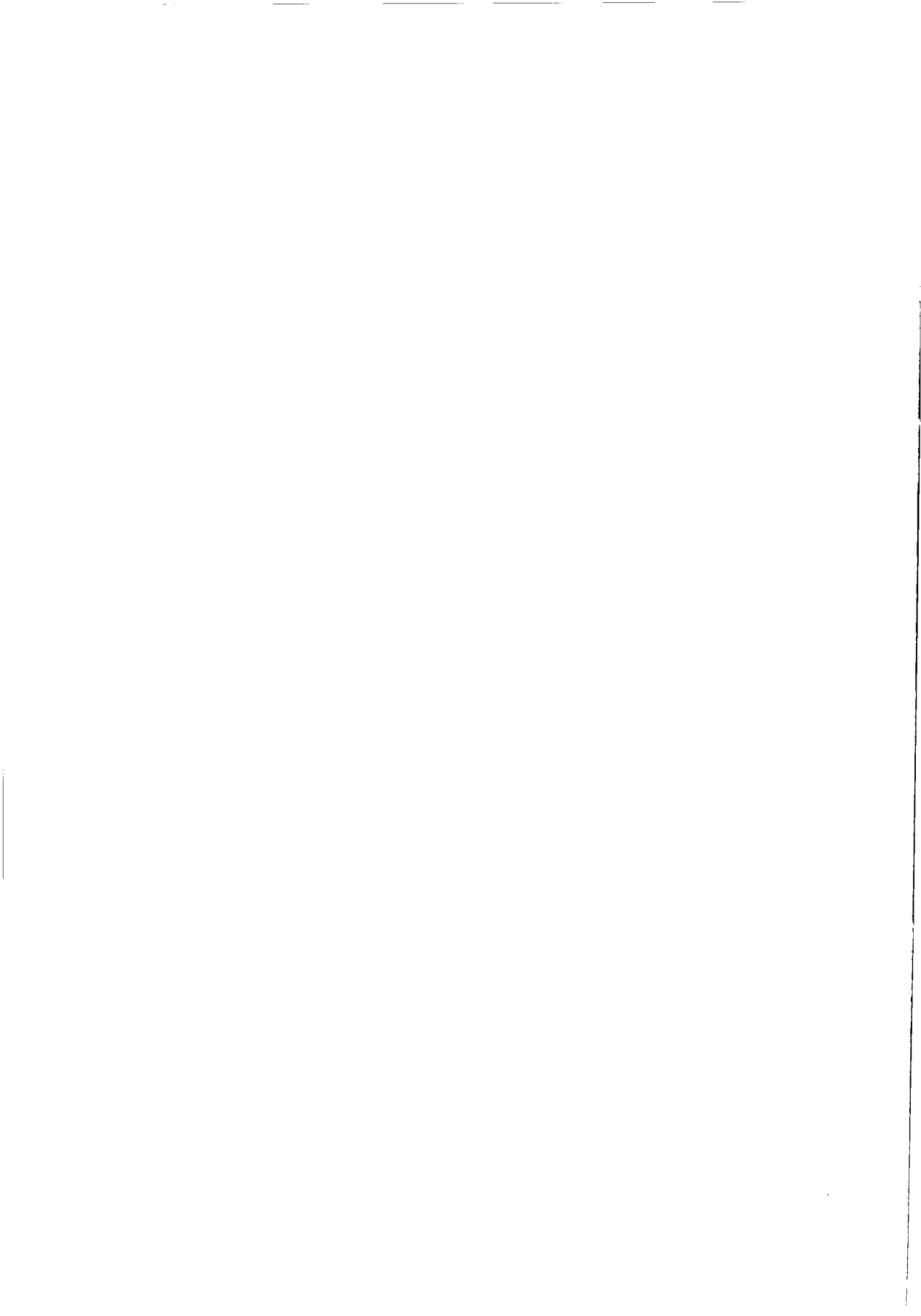

## **Characterization of green wastes' transformations occurring while composting**

*Caractérisation des transformations des déchets verts lors de leur compostage.*

**A. de Guardia, D. Rogeau, F. Begnaud, S. Quinio**

Cemagref. Livestock and Municipal Wastes Management,  
17 avenue de Cucillé. CS 64427. 35 044 Rennes Cedex. France  
E-mail : amaury.de-guardia@cemagref.fr

### **Abstract**

*Though the process of composting offers technical advantages and leads to the production of compost used as amendment or fertilizer in agriculture, it often encounters some limitations due to a lack of control parameters and some difficulties to characterize the stabilization of organic matter.*

*In order to better understand the process and characterize the compost's stabilization, we studied green wastes' transformations occurring while composting at an industrial plant.*

*Characterization consisted in granulometric fractionation and chemical analysis of the fractions and the global solid : dry matter, organic matter, organic carbon, Kjeldahl nitrogen. Aqueous extractions of the solids have been realized and pH, chemical oxygen demand, Kjeldahl nitrogen and ammonium ions of the extracts have been measured.*

*The solid organic matter characterization shows it fast doesn't change except Kjeldahl nitrogen contents which have a sensitive relative evolution. The calculation of organic matter elimination rate describes well the biodegradation slowing down. The concentrations variations in the aqueous extracts are more sensible and chemical oxygen demand is indicative of the different steps of the process.*

### **Résumé**

Bien que le procédé de compostage offre de nombreux atouts techniques et conduise à la production d'un compost utilisable en tant qu'amendement ou fertilisant en agriculture, il présente un certain nombre de limites liées à une mauvaise connaissance de paramètres de contrôle et à certaines difficultés à caractériser la stabilisation de la matière organique.

Dans l'objectif de mieux comprendre le procédé et de caractériser la stabilisation de la matière organique, nous avons étudié les transformations de déchets verts traités par compostage sur site industriel.

La caractérisation a consisté en un fractionnement granulométrique et une analyse chimique de fractions et de solide global : matière sèche, matière organique, carbone organique, azote kjeldahl. Des extractions en phase aqueuse des solides ont été réalisées et le pH, la demande chimique en oxygène, l'azote kjeldahl et l'ammoniac des extraits aqueux ont été dosés.

La caractérisation de la matière organique initialement solide montre que sa composition ne change presque pas à l'exception de sa concentration en azote dont la variation est plus sensible. Le calcul des taux d'élimination de la matière organique décrit bien le ralentissement de la biodégradabilité. Les variations de concentration dans les extraits aqueux sont en revanche plus significatives et l'évolution de la demande chimique en oxygène traduit bien les différentes étapes du procédé.

## **1. Introduction**

The treatment of organic wastes by composting offers a few technical advantages which are for instance the possibility to treat a large range of quantities of wastes with a high or in the contrary a low level of technology. The characteristics of organic wastes, their moisture and their ability to biodegrade, favour the development of composting. Finally composting leads to the production of compost which may be used as amendment or fertilizer in soils. This last advantage also constitutes a present limit of the process that means the obligation for compost produced to satisfy a sufficient quality. This demand imposes to identify physical, chemical or microbiological parameters indicating for instance stabilisation of the product. A better control of the process also requires the identification of process control parameters.

The research of process control and stabilisation parameters has been the object of many studies. The wastes whose evolution during composting was studied were mainly solid wastes from animal husbandry, organic fraction from municipal wastes, municipal sewage sludge and green wastes. These were treated in industrial composting plants or in composting simulation pilots. These studies show it is sometimes difficult to determine a singular parameter that would be suitable for every organic waste. The concept of maturity also includes the specific use that will be made of the compost and it imposes to take into account in the parameter identification the future compost's application. However considering the kinetic decrease of the concentrations may be an indicator of stabilization and the determination of parameters describing this decrease could permit a better control of the process. Our study consisted in the characterization of the green wastes' transformations occurring during composting on an industrial plant and in the identification of parameters, between those already tested, which could be applicable to the green wastes. Assuming that most of the biological activity took place in the liquid film, we interested both in the global solid product and the

aqueous extracts. By another way we preferred follow up parameters which could give later quantitative process informations. Granulometric fractionation has been realized and for every granulometric range, chemical parameters particularly some used in characterization of waste water have been experimented both on dried and ground solid and on aqueous extracts : organic matter (OM) and its main components on solid, pH, chemical oxygen demand and nitrogen species (NK : Kjeldahl nitrogen,  $\text{NH}_4^+$  : ammonium ions) of the aqueous extracts.

## 2. Literature review

In order to search stabilization or process control indicators, many different types of parameters have been tested.

Physical parameters such like temperature (Mustin<sup>1</sup>), odour (Mustin<sup>1</sup>, Chanyasak *et al*<sup>2</sup>, Jimenez and Garcia<sup>3</sup>, Harada *et al*<sup>4</sup>) and colour (Jimenez and Garcia<sup>3</sup>, Sughara *et al*<sup>5</sup>) have been experimented. If a low temperature, a black colour and absence of odours may characterize a stabilized compost, these indicators remain too imprecise to define the degree of stabilisation.

Chemical parameters have been measured on the global solid phase, humid or after drying and grinding or on the aqueous extracts obtained by a solid-liquid extraction of the composting product. The solubilization and transformation of organic matter by the microorganisms means at first the release, in the liquid film around the solid matter, of carbohydrates, amino and volatil acids, phenols (Hirai *et al*<sup>6</sup>) which will be biodegraded and transformed in carbon dioxide. This mineralization of the organic matter is responsible for the decrease then the increase of pH which have been already wide exposed (Jimenez and Garcia<sup>3</sup>, Harada *et al*<sup>4</sup>, Inbar *et al*<sup>7</sup>). The decrease and stabilization of the global organic matter and the release of the acids have been studied by Garcia *et al*<sup>8</sup> and Insam *et al*<sup>9</sup>. Inbar *et al*<sup>10</sup>, Dinel *et al*<sup>11</sup> and Mathur *et al*<sup>12</sup> associated the concentrations of the dissolved components to optic density of aqueous extracts at 280, 465 and 665 nm and found they were well corelated to the composting time. Concentrations of low molecular weight amino and volatil acids inferior to 1 mg/g dry compost would indicate the stabilisation of the compost (Chanyasak and Kubota<sup>13</sup>). Bernal *et al*<sup>14</sup> found for different composts that a value of 1,7 % of dissolved carbon was indicative of stability. The mineralization of the organic matter leading to the production of carbon dioxide causes a decrease of the global chemical oxygen demand (COD) which yet may be sensible in mass and not sensible in concentration. A decrease of COD is for Mustin<sup>1</sup> (COD < 350 mg/g of compost) and Insam *et al*<sup>15</sup> indicative of stabilisation whereas for Godden<sup>16</sup> this decrease isn't always clear.

Nitrogen transformations through organic matter mineralization, nitrification and denitrification have been often studied too. Some authors gave indicative concentrations of  $\text{NH}_4^+$  ( $\text{NH}_4^+ < 0.04$  % dry matter for Zucconi and De Bertoli<sup>17</sup>, absence of  $\text{NH}_4^+$  for Harada *et al.*<sup>14</sup> in animal wastes' composts,  $\text{N-NH}_4^+ < 0.04$  % for Bernal *et al.*<sup>14</sup> in sewage sludges' and animal wastes' composts),  $\text{NO}_3^-$  ( $\text{NO}_3^- > 300$  mg/kg dry compost from municipal sewage sludge, Forster *et al.*<sup>18</sup>) and value or tendency of  $\text{NH}_4^+/\text{NO}_3^-$  ( $\text{NH}_4^+/\text{NO}_3^- < 0.16$  for Bernal *et al.*<sup>14</sup>,  $\text{NH}_4^+/\text{NO}_3^-$  between 0.03 to 18.9 for Hirai *et al.*<sup>6</sup> and it must decrease for Insam *et al.*<sup>15</sup>). For Mathur *et al.*<sup>19</sup> no particular level of nitrate or its ratio to ammonia can be relied as indicator of compost biomaturity.

Taking into account both elimination of carbon and nitrogen, C/N ratio has been wide employed as indicator of maturity. For instance after tests on different sewage sludges' and animal wastes' composts, Bernal *et al.*<sup>14</sup> measured a C/N value of 12 as maturity level. Many authors (Harada *et al.*<sup>14</sup>, Chanyasak and Kubota<sup>13</sup>, Wong and Chu<sup>20</sup>) don't agree with C/N indication particularly because of its large fluctuation according to the initial waste's nature. Godden<sup>16</sup> and Van de Kerkhove<sup>21</sup> prefer consider its evolution with time than a particular value. The C/N ratio has been measured in the aqueous extracts too and values around 5-6 have been proposed by Chanyasak *et al.*<sup>2</sup>, Chanyasak and Kubota<sup>13</sup>, Hirai *et al.*<sup>22</sup>, Iannotti *et al.*<sup>23</sup> and Canet and Pomares<sup>24</sup>. A too high concentration of nitrogen in the initial waste (municipal sewage sludge) would exclude its utilisation as indicator (Inbar *et al.*<sup>7</sup>).

For Inbar *et al.*<sup>10</sup>, the stabilisation of aqueous extracts conductivity, whose  $\text{Ca}^{++}$ ,  $\text{Mg}^{++}$  and  $\text{NO}_3^-$  are mostly responsible for, may be indicative of stabilisation too. Yet Avnimelech *et al.*<sup>25</sup> showed the evolution of the aqueous extracts conductivity may be difficult to interpret and must account for the complexation degree of anions and cations with organic matter.

The aerobic biological activity can be described by measure of microbiological parameters such like the oxygen consumption or carbon dioxide production (Mustin<sup>1</sup>, Forster *et al.*<sup>18</sup>, Mahmood *et al.*<sup>26</sup>, Iannotti *et al.*<sup>27</sup>), the enzymatic activity (Godden<sup>16</sup>, Forster *et al.*<sup>18</sup>). Bacteriological identification and numeration have been studied by Insam *et al.*<sup>6</sup>.

The biochemical composition of the solid phase and its specific properties characterizing its stabilization level have been studied too. So after a chemical extraction, cellulose, hemicellulose and lignin concentrations have been measured according to Van Soest<sup>28</sup> and Adani<sup>29</sup> fractionation methods and associated to carbon dioxide production (Linéres<sup>30</sup>). An indice of biological stabilisation (BSI) has been defined which allows to associate potential of mineralization to biochemical composition. Humic substances' increase (Garcia *et al.*<sup>3</sup>, Mahmood *et al.*<sup>26</sup>, Chefetz *et al.*<sup>31</sup>) and measure of distinct fractions as humic and fulvic acids, non humic fractions and calculation of different ratios have been tested by Inbar *et al.*<sup>7</sup>, Forster *et al.*<sup>18</sup>, Roletto and Barberis<sup>32</sup>, De Nobili and Petrusci<sup>33</sup>, Ciavatta *et al.*<sup>34</sup>, Govi *et al.*<sup>35</sup>. The increase and stabilisation of the cation exchange capacity (CEC) is often

recognized as a good indicator too : CEC > 100 meq./100 g O.M. (Organic Matter) for animal wastes (Harada and Inoko<sup>36, 37</sup>) and municipal wastes (Van de Kerkhove<sup>21</sup>), CEC > 20 meq./100 g OM for green wastes (Mahmood *et al*<sup>26, 38</sup>). Inbar *et al*<sup>7, 39</sup> and found a corelation between CEC and humic substances increases. The difference between extractible lipids in diethylether and in chloroform has been proposed by Dinel *et al*<sup>11</sup> as a maturity indicator. Biochemical changes of the organic matter and particularly its aromatization may be characterized by spectrometric parameters such like IR and CPMAS <sup>13</sup>C-RMN (Cross Polarization Magic Angle Spinning) (Inbar *et al*<sup>7, 39</sup> and Chefetz *et al*<sup>29</sup>). Thermogravimetric methods have been experimented by Blanco and Almendros<sup>40</sup>. Chemical parameters have been measured on the alcalin extracts : IEF (isoelectric focusing) by Ciavatta *et al*<sup>34</sup> and Govi *et al*<sup>35</sup>, UV absorption by Prudent *et al*<sup>41</sup>.

Finally these chemical and biochemical transformations increase agronomic quality of composts. Phytotoxicity, germination (Bernal *et al*<sup>14</sup>, Blanco and Almendros<sup>40</sup>, Zucconi *et al*<sup>42</sup>, Baca *et al*<sup>43</sup>) and growth (Inbar *et al*<sup>10</sup>, Bernal *et al*<sup>14</sup>, Iannotti *et al*<sup>23</sup>, Chefetz *et al*<sup>31</sup>, Mahmood *et al*<sup>38</sup>, Blanco and Almendros<sup>40</sup>, Baca *et al*<sup>43</sup>) tests have been improved.

### **3. Materials and methods**

#### **3.1. The composting plant**

The plant collects green wastes brought by inhabitants of the nearest agglomerations and public or private professionals. These green wastes compose themselves of branches, leaves, weeds, cut grass. These are weighed then ground and stacked in windrows on a cemented uncovered area. Seven windrows take place on the area. Every windrow has a trapezoïdal cross section (30 m x 10 m and 3 m high) and an initial mass of 500 to 1 500 tonnes. The windrows are turned every 15 to 21 days by a mobile equipment. For the first three months, in case of insufficient moisture, water may be sprayed above. After six to seven months composting, the product is separated, using two rotative sieves of 10 and 20 mm, to the undersized, the compost, the middlesized, the mulch and the oversized which is recycled in grinding at the beginning of the process. The compost is stocked on a covered area.

Transformations occuring in three windrows of green wastes stacked in february (2-97), march (3-97) and april (4-97) 1997 have been characterized. The experiment last about eight months from grinding to the final refining. The three windrows have been sampled every time they were turned (8 to 10 times) and the analysis have been realised for every sample.

### 3.2. On sites sampling and measurements

Temperature has been measured and samples have been collected every time the windrows were turned. Temperature was measured before turning by introduction of a thermometer probe in about twenty points at the surface of the windrow to a depth of 1,50 m and the mean temperature has been calculated.

When the mobile equipment is going through the windrow, it turns about 30 cm larg of the pile. At every passage, we collected manually about 10 kg of product in the cross trapezoïdal section. At the end, the global sample (# 300 kg) has been reduced (by successive division in identical portions) to about 30 kg.

### 3.3. Solids and liquids preparation for analysis

We supposed solids' transformations were different whether the products were constituted in big or little fragments. More, fractionation allowed to get a more representativ sample for analysis. Finally in order to characterize the aqueous extracts, fractionation was realized on humid solid. Then, using two vibrating plane sieves with square meshes of 6,3 mm and 25 mm, about 10 to 20 kg of humid product were separated to four fractions :  $F_1 < 6,3$  mm,  $6,3$  mm  $< F_2 < 25$  mm,  $0 < F_3 < 25$  mm,  $F_4 > 25$  mm. Half part of each fraction except  $F_4$  has been dried at  $40^\circ\text{C}$  then ground to particles  $<$  to  $500$   $\mu\text{m}$ . The big dimensions of solids of  $F_4$  exclude to grind it with our equipments but its low percentage in regard of the total humid weigh ( $< 10$  %) led us to consider the solid inferior to  $25$  mm as the global product. The second half parts of  $F_1$ ,  $F_2$ ,  $F_3$  have been extracted three times in series by deionized water ( $100$  g /  $500$  ml). Each extraction last 4 hours and the three extracts have been mixed together and filtered at  $8\mu\text{m}$ .

### 3.4. Analysis of solid and aqueous extracts

#### 3.4.1. Analysis of solids

In order to reduce analysis' errors due to heterogeneity of the global sample (0/25), we measured the interesting parameter for every granulometric fractions, (0/6,3) and (6,3/25), and in respect of their ponderate contribution we calculated by addition the parameter which should have been measured on the global solid. This method has been validated before practise with ten samples for which we verified :

$$G_{0/25} * (1 - H_{0/25}) * P_{0/25} = G_{0/6,3} * (1 - H_{0/6,3}) * P_{0/6,3} + G_{6,3/25} * (1 - H_{6,3/25}) * P_{6,3/25}$$

$G_i$  humid weight percentage of  $F_i$  above the global humid weigh,

$H_i$  moisture of fraction  $F_i$ ,

$P_i$  physico-chemical parameter measured on fraction  $F_i$ .

Dry matter has been measured by drying at 105°C and organic matter at 550°C for 6 hours. Global ash content has been computed as reference to estimate dry matter content at every time. Carbon has been measured by combustion at 1200°C and absorption of emissions of CO<sub>2</sub> and H<sub>2</sub>O. Total carbon includes organic carbon and a part of mineral carbon volatil at 1200°C. We chose to estimate organic carbon by supposing it was equally distributed among organic matter at 550°C and volatil matter between 550°C and 1200°C. Kjeldahl nitrogen has been measured by fitting standard methods of water analysis to dried ground solids. So, Kjeldahl nitrogen is measured by mineralisation at boiling of 1 g solid in 25 ml sulfuric acid. The reaction is catalysed by CuSO<sub>4</sub>, 5 H<sub>2</sub>O, K<sub>2</sub>SO<sub>4</sub> (Kjeltabs CK). When the mineralization is finished, the sample is cooled, 60 ml water are added and it is basified by addition of 120 ml of sodium hydroxyde 30 % . Then ammonium is measured according standard method of water analysis.

In order to calculate the percentage of elimination of dry matter, we have to estimate the total weight of the windrow we can't measure. We supposed the total mass of mineral matter (MM) remained constant during the process,  $mMM_0 = mMM_t$ , then we calculated the total mass of dry matter  $mDM$ . The organic matter mass ( $mMO$ ) can be calculated too.

$mMM_i$ ,  $mMM_0$ ,  $mMM_t$ , mineral matter masses in fraction  $F_i$  and in global product at the beginning and at  $t$ ,

$mDM_i$  and  $mDM$ , dry matter masses of fraction  $F_i$  and global product,

$OM_i$ , organic matter concentration in fraction  $F_i$ ,

$G_i$ , ratio of humid weight of  $F_i$  above total humid weight,

$H_i$  and  $H$ , moisture of fraction  $F_i$  and of global product,

$mH$  humid mass of global product,

$mOM_i$  and  $mOM$ , organic matter masses in fraction  $F_i$  and in the global product.

$$mMM_i = mDM_i (1 - OM_i),$$

$$mMM_0 = mMM_t = \sum_i mMM_i = \sum_i mDM_i \times (1 - OM_i),$$

$$mDM_i = mH \times G_i \times (1 - H_i),$$

$$mMM_0 = mH \times \sum_i G_i \times (1 - H_i) \times (1 - OM_i),$$

then we calculate  $mH$ ,  $mD_i$ ,  $mOM_i$ ,  $mDM$  and  $mOM$ :

$$mDM_i = mH \times G_i \times (1 - H_i), \quad mDM = \sum_i mDM_i,$$

$$mOM_i = mDM_i \times OM_i, \quad mOM = \sum_i mOM_i.$$

### 3.4.2. Analysis of aqueous extracts

After filtration at 8µm, the aqueous extracts have been analysed : pH, COD, N-NK and NH<sub>4</sub><sup>+</sup> have been measured according standard methods of water analysis.



## 4. Results and discussion

### 4.1. Temperature

From 20 to 150 days old the temperature in the compost is superior to 70 °C. From 150 to 200 days old the temperature slowly decreases of about 3 to 5 degrees which may mean a decrease in the degradation transformations.

### 4.2. Solid phase analysis

#### 4.2.1. Granulometric characterization

The global humid product has been separated by sieving into three granulometric fractions : F1 < 6,3 mm, 6,3 mm < F2 < 25 mm, F4 > 25 mm. We can observe (fig.1) the product gets always finer, that means the increase of the finer fraction and in the contrary the corresponding decrease of the fraction 6,3/25. In spite of grinding effect of turning and aerobic degradation, the upper fraction F4 remains fast constant in weight. This fraction accounts for less than 10 percent of the total weight of humid solid and the fraction 0/25 has been considered as the global solid.

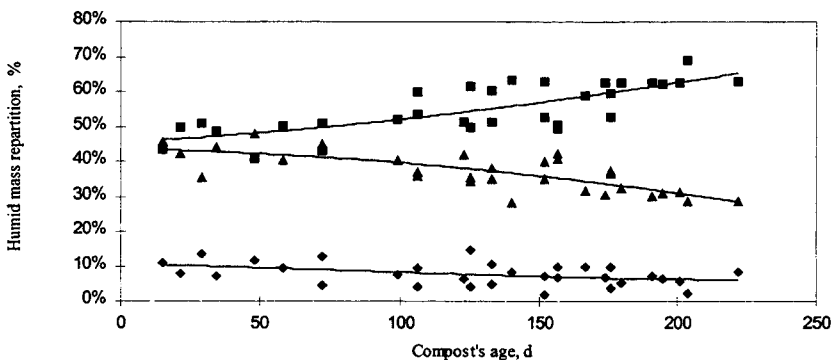

Figure 1.

Granulometric fractionation of the global humid composting product:  
(■) fraction 0 / 6,3 (mm); (▲) fraction 6,3 / 25 (mm); (◆) fraction > 25 (mm)

#### 4.2.2. Moisture concentration

During the first month of composting, moisture of the global solid is between 45 % to 55 %. This moisture remains constant, 47 % to 50 % at the end of the treatment, which may be explained by water bringing from atmospheric precipitations and human process control. The moisture of the different fractions is around 50 % at the beginning. It remains constant for the fractions 6,3/25, slightly increases for the fraction > 25 mm and it decreases to 45 % in 200 days for the fraction 0/6,3.

#### 4.2.3. Dry matter elimination

Measures of  $G_i$ ,  $H_i$  and  $OM_i$  for every fraction and application of formulations explained in § 3.4.1 allow to calculate dry matter masses and their evolutions. Dry matter elimination is fast constant all along the 200 days process though we can suppose it slowly decreases at the end (fig.2). For the three, dry matter elimination rates are around 15 to 25 % at the end of the experiment.

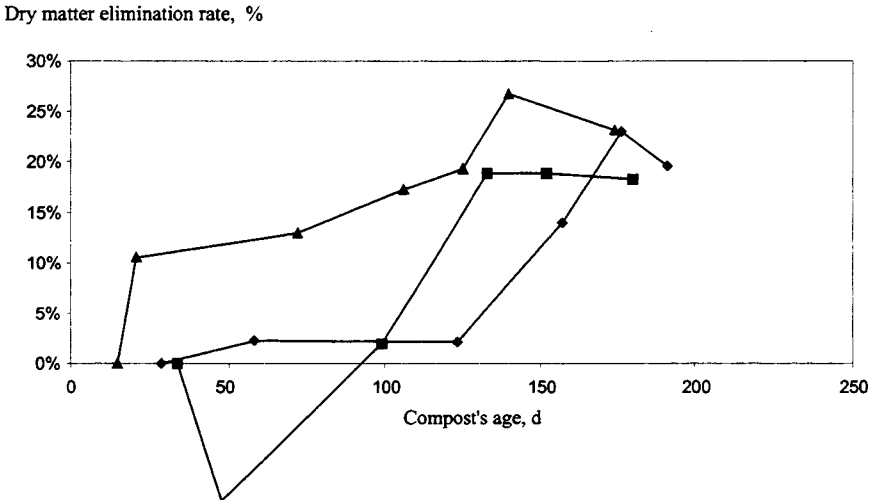
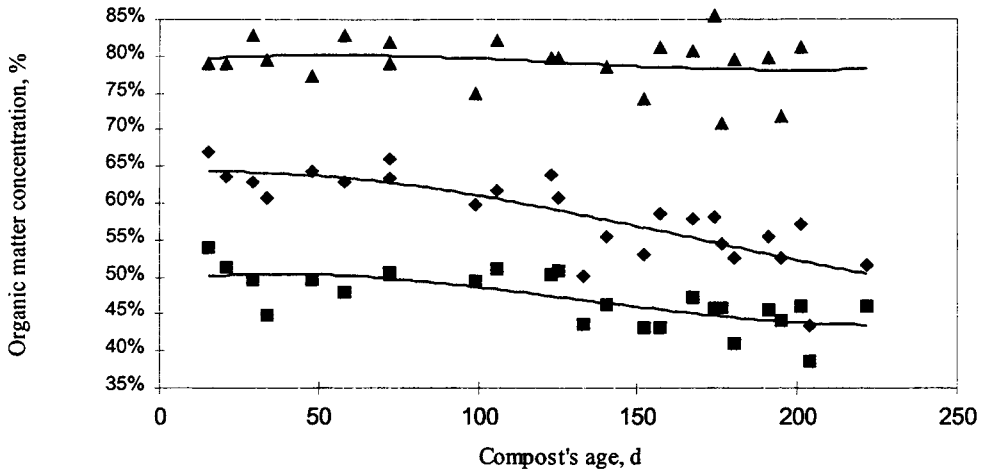

Figure 2  
Global dry matter elimination rate for the windrows: (◆) 2-97; (■) 3-97; (▲) 4-97

#### 4.2.4. Organic matter concentrations and masses

After grinding the organic matter concentrations of the 0/6,3 and 6,3/25 fractions, in the three windrows, are respectively around 55 % and 78 to 83 %. The smaller concentration of the fraction 0/6,3 is due to the presence of mineral matter as fragments of soils. The concentration of organic matter in the fraction 6,3/25 remains constant whereas it decreases of 5 to 10 % in the finer fraction (fig.3). The organic matter content of the fraction > 25 mm remains constant too,  $OM = 0,85$ . The organic matter content of the global solid (0/25 fraction) decreases slightly from 65 to 55 %. Organic matter concentration decreases too slowly to be considered as indicator of stabilisation and more it depends closely of the initial wastes. Yet the measure of organic matter may be interesting if dry matter mass has been estimated. In that case, global organic matter masses decrease and the organic matter elimination rate is closely tied to the elimination rate of dry matter. The evolution of that rate particularly at 200 days allows to conclude the biodegradation is diminishing. Yet the elimination rate has been calculated by supposing the global mineral matter mass was constant which will have to be confirmed in experimental controlled conditions, for instance in a composting simulation pilot.



*Figure 3*  
*Organic matter concentration in solid fractions and global solid*  
*for the three windrows 2-97, 3-97, 4-97 :*  
 (■) fraction 0 / 6,3 (mm); (▲) fraction 6,3 / 25 (mm); (◆) global solid

#### 4.2.5. Organic carbon and Kjeldahl nitrogen concentrations in the global solid

Organic carbon concentrations and organic matter concentration are closely tied and exhibit a some low decrease in fraction and in the global product. In global product organic carbon concentration decrease from 35 or 30%. In the contrary of carbon concentrations which are the same in every windrow of compost, Kjeldahl nitrogen concentrations are superior in case of windrow 4-97 than in windrows 2-97 and 3-97. This superiority explains itself by the higher concentration of 4-97 in more biodegradable green wastes such like grass, leaves ... We can observe a sensitive but regular increase in nitrogen from 0,8 to 1,1 % for 2-97. For both carbon and nitrogen, we can't observe different rates in the evolution of concentrations.

The small variations observed in the transformations of the solid, in particular in the concentrations in organic matter and its main components and in spite of the higher relative variations of nitrogen, don't allow to consider them as interesting parameters to control the composting process or indicate organic matter stabilisation. Calculation of dry matter masses and measure of organic matter concentrations allow to calculate organic matter masses and describe their evolution. So we showed the organic matter elimination rate decreased at the end of the treatment.

### 4.3. Liquid phase characterization

Only the analysis results of aqueous extracts of the fraction 0/25 have been exposed, we can yet mention the concentrations measured in the aqueous extracts of the fractions 0/6,3 and 6,3/25 were equal to the concentrations measured in aqueous extracts of the fraction 0/25. Elsewhere we calculated concentrations of COD, N-NK and  $N-NH_4^+$  in respect of the global volum of biofilm ( $V_{\text{biofilm}} = mDm \times H$ ). As the moisture is around 50 % these concentrations are fast equal in respect of global dry matter. Finally, for a same age of the three composts, we can notice a large dispersion of pH, COD, N-NK and  $N-NH_4^+$  values. These differences may be explained by their specific nature: pieces of wood, leaves, cut grass ... which are more or less soluble in aqueous phase in spite of their same origin.

For the windrow 4-97, we observed (fig.4), at the begining of the treatment, the acidification of the aqueous extracts which can be explained by the hydrolysis of organic matter and release of organic acids (Jimenez and Garcia<sup>3</sup>, Inbar *et al*<sup>7</sup>, Harada *et al*<sup>1</sup>). After that first step of acidification, the pH increases which we observed in the three windrows (fig.4). This increase from values between 6 at 7 to values around 8 at 9 is corresponding to the release of ammonia and other basic components in the liquid film, and the elimination of organic acids.

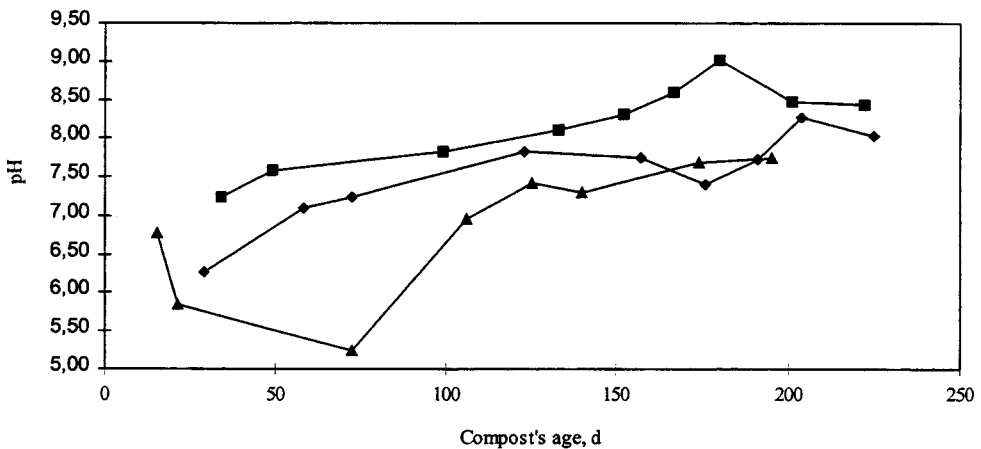

Figure 4

pH of the aqueous extracts for the windrows: (◆) 2-97; (■) 3-97; (▲) 4-97

The evolution of pH is intimately tied to release and remove of organic matter in the biofilm surrounding the solid phase. A sensitive parameter of that organic matter evolution may be the COD concentration in the biofilm (COD has been measured in the aqueous extracts then expressed in respect of moisture that means the global volume of biofilm in the compost). COD (fig.5) is first increasing in case of windrow 4-97 as the pH was decreasing in the same time which improves their great

corelation. For the three windrows, after that first increase for the windrow 4-97, we observe the decrease of COD concentration in the biofilm. If we keep in mind the moisture in the windrows is slightly decreasing, the COD decrease is as much higher in mass. After a step of transfer from solid to liquid of organic matter which is responsible for the first increase, the consumption of that dissolved organic matter explains the second diminution step. At the end of the treatment we can see a slight back rise of COD which may be due to a continuous transfer but a falling down microbiological consumption : dissolved organic matter is not biodegradable or necessary conditions for microbiological metabolism aren't gathered anymore. We can notice the high COD concentrations in the biofilm, 10 to 60 g / l, still higher for the windrow 4-97 which may be explained by the green wastes' composition in april, containing more cut grass and leaves whose soluble fraction is greater than for branches... .

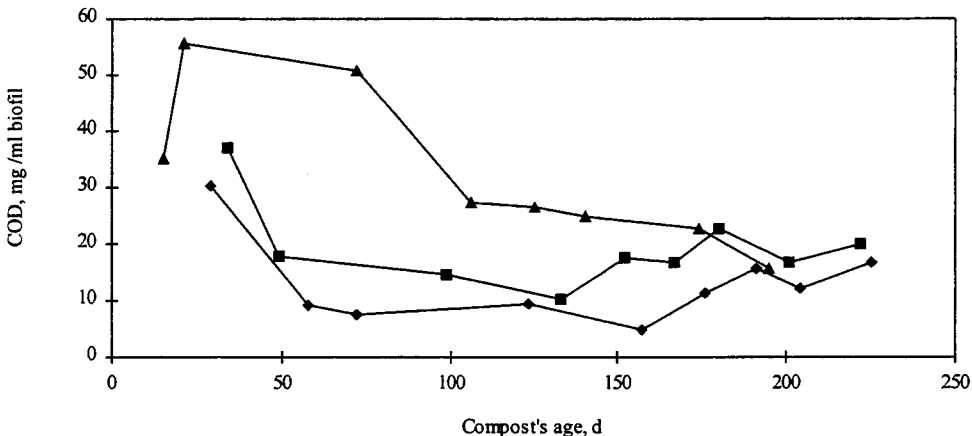
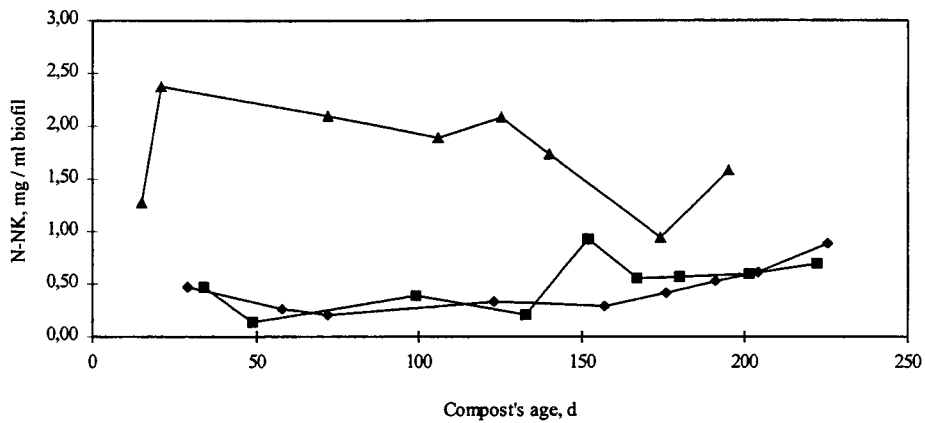

Figure 5

COD concentrations in the biofilm for the windrows: (◆) 2-97; (■) 3-97; (▲) 4-97

Kjeldahl nitrogen and ammonium concentrations (fig. 6, fig. 7) have fast equal evolution as COD concentration : a first increase for windrow 4-97 then a decrease for the three piles and finally a back growth at the end of the treatment. Kjeldahl nitrogen and ammonium concentrations are respectively in the range of 0,2 to 1 g.l<sup>-1</sup> and 0,1 to 0,8 g.l<sup>-1</sup> for the windrows 2-97 and 3-97. They are superior for the windrow 4-97 : 1,2 to 2,2 g.l<sup>-1</sup> for N-NK and 0,6 to 1,2 g.l<sup>-1</sup> for N-NH<sub>4</sub><sup>+</sup>. Nitrogen concentrations are well corelated to the COD concentrations. So we can share the first one hundred days corresponding to the biggest product transformations from the second part corresponding to slower matter conversions then the final part which shows the slowing down microbiological metabolism.



*Figure 6*  
*Kjeldahl nitrogen concentrations in the biofilms*  
*for the windrows: (◆) 2-97; (■) 3-97; (▲) 4-97*

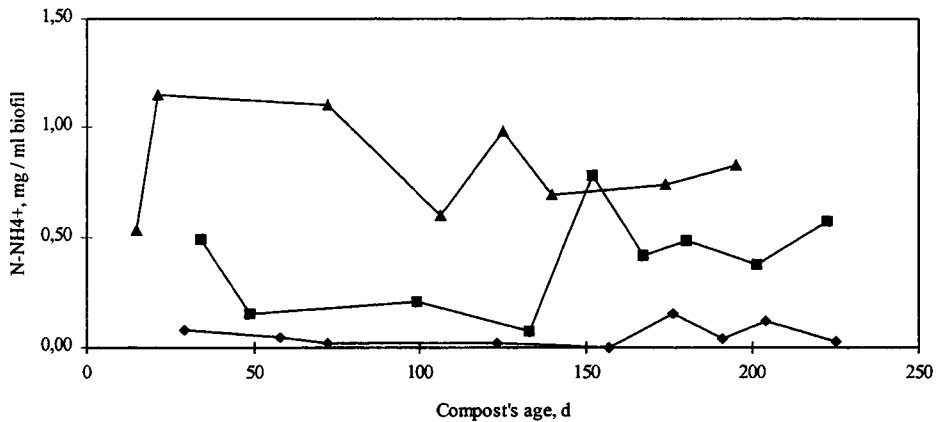

*Figure 7*  
*Ammonium concentrations in the biofilm for the windrows :*  
*(◆) 2-97; (■) 3-97; (▲) 4-97*

We can conclude the characterization of the dissolved organic matter can be used to describe the decreasing transformations of the composting product and so it can provide process control parameters. Yet it could be interesting to measure separately which quantity of organic matter is transferred and which one is microbiologically consumed in the same time. Such an approach would allow to quantify the different steps of the process : increasing then decreasing transfer from solid to liquid followed by the increase then the decrease of the biological consumption.

## 5. Conclusions

Through the characterization of green wastes' transformations occurring while composting process, that study had two main objectives : a better understanding of the composting process and the identification of process control and organic matter stabilization parameters. So we showed :

- the concentrations measured on the solid for instance in organic matter, organic carbon and nitrogen vary too lowly or/and slowly to be considered as process control or organic matter stabilization parameters,
- by calculation it is possible to determine organic matter masses and elimination rates which well describe the final slowing down of degradation, conservation of mineral matter mass will have to be verified in controled experimental conditions,
- the concentrations measured on the aqueous extracts are more sensitive and their variations well corelated. So the pH and COD, N-NK and N-NH<sub>4</sub><sup>+</sup> concentrations describe well the process and the stabilization of the organic matter at the end of the treatment. After a first increase of COD and nitrogen contents corresponding to the transfer of organic matter from solid to liquid phase, the biological consumption of organic matter is responsible for their diminution. Their back increase at the end of the treatment may be due to the pursuit of the transfer whereas biological consumption stopped. We have to keep in mind the slowing down degradation may be caused by depletion of nutrients like carbon or nitrogen but water too, which doesn't mean the product is stabilized.
- the single control of COD could be used as stabilization indicator and process control parameter. Yet that type of study will have to be realized for other wastes like waste water sludges, manure,
- it could be interesting to quantify separately the transfer and the biological consumption.

## 6. References

<sup>1</sup> **Mustin M.** Le compost, gestion de la matière organique. Paris : Edition François Dubusc, 1987.

<sup>2</sup> **Chanyasak V; Hirai M; Kubota H.** Changes of chemical components and nitrogen transformation in water extracts during composting of garbage. Journal of Fermentation Technology 1982, 60, 439-446.

- <sup>3</sup> **Jimenez E I; Garcia V.** Evaluation of city refuse compost maturity : a review. *Biological Wastes* 1989, 27, 115-142.
- <sup>4</sup> **Harada Y; Inoko A; Tadaki M; Izadaki T.** Maturing process of city refuse compost during piling. *Soil Science Plant Nutrition* 1981, 27, 357-364.
- <sup>5</sup> **Sughara K; Harada Y; Inoko A.** Color change of city refuse during composting process. *Soil Science Plant Nutrition* 1979, 25, 197-208.
- <sup>6</sup> **Hirai M F; Chanyasak V; Kubota H.** A standard measurement for compost maturity. *Biocycle* 1983, 24, 54-56.
- <sup>7</sup> **Inbar Y; Chen Y; Hadar Y; Hoitink H.** A New approaches to compost maturity. *Biocycle* 1990, 31(12), 64-69.
- <sup>8</sup> **Garcia C; Hernandez T; Costa F.** Changes in carbon fractions during composting and maturation of organic wastes. *Environmental Management* 1991, 15(3), 433-439.
- <sup>9</sup> **Insam H; Amor K; Renner M; Crepaz C.** Changes in fonctionnal abilities of the microbial community during the composting of manure. *Microbiological Ecology* 1996, 31, 77-87.
- <sup>10</sup> **Inbar Y; Hadar Y; Chen Y.** Recycling of cattle manure : the composting process and characterization of maturity. *Journal of Environmental Quality* 1993, 22, 857-863.
- <sup>11</sup> **Dinel H; Schnitzer M; Dumontet S.** Compost maturity : chemical characteristics of extractable lipids. *Compost Science and Utilization* 1996, 4(1), 16-25.
- <sup>12</sup> **Mathur S P, Dinel H, Owen G, Schnitzer M.** Determination of compost biomaturity: II. Optical density of water extracts of composts as a reflexion of their maturity. *Biological Agriculture and Horticulture* 1993, 10, 87-108.
- <sup>13</sup> **Chanyasak V; Kubota H.** Carbon/organic nitrogen ratio in water extract as measure of composting degradation. *Journal of Fermentation Technolgy* 1981, 5(3), 215-219.
- <sup>14</sup> **Bernal M P; Paredes C; Sanchez-Monedero MA; Cegarra J.** Maturity and stability parameters of composts prepared with a wide range of organic wastes. *Bioresource Technology* 1998, 63, 91-99.
- <sup>15</sup> **Insam H; Amor K; Renner M; Crepaz C.** Changes in fonctionnal abilities of the microbial community during the composting of manure. *Microbiological Ecology* 1996, 31, 77-87.



- <sup>16</sup> **Godden B.** Les tests enzymatiques et chimiques de maturité des composts. *Compost Information* 1986, 22, 20-24.
- <sup>17</sup> **Zucconi F; De Bertoldi M.** Compost specifications for the production and characterization of compost from municipal solid waste. *Compost : Production, quality and use.* Essex : Elsevier Applied Science, 1987, 30-50.
- <sup>18</sup> **Forster J C; Zech W; Würdinger E.** Comparison of chemical and microbiological methods for the characterization of the maturity of composts from contrasting sources. *Biological Fertilisation of Soils* 1993, 16, 93-99.
- <sup>19</sup> **Mathur S; Owen G; Dinel H; Schnitzer M.** Determination of compost biomaturity. 1. Literature review. *Biological Agriculture* 1993, 10 , 65-85.
- <sup>20</sup> **Wong M; Chu L.** Changes in properties of a fresh refuse compost in relation to root growth of *Brassica chinensis*. *Agricultural Wastes* 1985, 14, 115-125.
- <sup>21</sup> **Van de Kerckhove J M.** Evolution de la maturité de trois déchets urbains en cours de compostage. PHD Institut National Polytechnique de Lorraine, 1990.
- <sup>22</sup> **Hirai M F; Chanyasak V; Kubota H.** Measuring for compost maturity : Using the organic-carbon : organic-nitrogen ration in water extract. In *Managing sludge by composting*, J.G. Press; Emmaus, Pa, 1985.
- <sup>23</sup> **Iannotti D; Grebus M; Toth B; Madden L; Hoitnik H.** Oxygen respirometry to assess stability and maturity of composted municipal solid waste. *Journal of Environmental Quality* 1994, 23, 1177-1183.
- <sup>24</sup> **Canet R; Pomares F.** Changes in physical, chemical and physicochemical parameters during the composting of municipal solid wastes in two plants in Valencia. *Bioresource Technology* 1995, 51, 259-264.
- <sup>25</sup> **Avnimelech Y; Bruner M; Ezrony I; Sela R; Kochba M.** Stability indexes for municipal solid waste compost. *Compost Science & Utilization* 1996, 4(2), 13-20.
- <sup>26</sup> **Mahmood T; Azam F; Malik K.** Biochemical changes during composting of Kallar grass (*Leptochloa fusca* L. Kunth). *Mircen Journal* 1987, 3, 421-428.
- <sup>27</sup> **Iannotti D; Pang T; Toth B; Elwell D; Keener H; Hoitink H.** A quantitative respirometric method for monitoring compost stability. *Compost Science & Utilization* 1993, 1(3), 52-56.
- <sup>28</sup> **Van Soest P J; Wine R. H** Use of detergents in the analysis of fibrous feeds. IV. Determination of plant cell wall constituents. *Journal of the association of Analytical Chemistry* 1987, 5, 501-511.

- <sup>29</sup> **Adani F; Genevini P L; Tambone F.** A new index of organic matter stability. *Compost Science and Utilization* 1995, 3 (2), 25-37.
- <sup>30</sup> **Linères M.** Pourquoi caractériser les amendements organiques. *PHM Revue Horticole* 1993, 337, 5-8.
- <sup>31</sup> **Chefetz B; Hatcher P; Hadar Y; Chen Y.** Chemical and biological characterization of organic matter during composting of municipal solid wastes. *Journal of Environmental Quality* 1996, 25, 776-785.
- <sup>32</sup> **Roletto E; Barberis R; Consiglio M; Jodice R.** Chemical parameters for evaluating compost maturity. *Biocycle* 1985, 26(2), 46-47.
- <sup>33</sup> **De Nobili M; Petrusi F.** Humification index (HI) as evaluation of the stabilization degree during composting. *Journal of Fermentation Technology* 1988, 66(5), 577-583.
- <sup>34</sup> **Ciavatta C; Govi M; Pasotti L; Sequi P.** Changes in organic matter during stabilization of compost from municipal solid wastes. *Bioresource Technology* 1993, 43, 141-145.
- <sup>35</sup> **Govi M; Ciavatta C; Sitti L; Gessa C.** Evaluation of the stabilization level of pig organic waste : influence of humic-like compounds. *Communications in Soil Sciences and Plant Analysis* 1995, 26(3&4), 425-439.
- <sup>36</sup> **Harada Y; Inoko A.** Relationship between cation-exchange capacity and degree of maturity of city refuse composts. *Soil Science & Plant Nutrition* 1980, 26, 353-362.
- <sup>37</sup> **Harada Y; Inoko A.** The measurement of the cation-exchange capacity of composts for the estimation of the degree of maturity. *Soil Science & Plant Nutrition* 1980, 26, 127-134.
- <sup>38</sup> **Mahmood T; Azam F; Malik K.** Large scale composting of Kallar grass *Leptochloa fusca* (L.) Kunth. *Pakistan Journal of Botany* 1991, 23(1), 40-47.
- <sup>39</sup> **Inbar Y; Chen Y; Hadar Y.** Solid-state carbon-13 nuclear magnetic resonance and infrared spectroscopy of composted organic matter. *Soil Science American Society Journal* 1989, 53, 1695-1701.
- <sup>40</sup> **Blanco M J; Almendros G.** Maturity assessment of wheat straw composts by thermogravimetric analysis. *Journal of Agricultural & Food Chemistry* 1994, 42, 2454-2459.

- <sup>41</sup> **Prudent P; Domeizel M; Massiani C; Thomas O.** Gel chromatography separation and UV spectroscopic characterization of humic-like substances in urban composts. *The Science of the Total Environnement* 1995, 172, 229-235.
- <sup>42</sup> **Zucconi F; Forte M; Monaco A; De Bertoldi M.** Biological evaluation of compost maturity. *Biocycle* 1981, 22, 27-29.
- <sup>43</sup> **Baca M; Delgado I; Sanchez-Raya A; Gallardo-Lara F.** Comparative use of cress seed germination and physiological parameters of *Helianthus annuus* L. to assess compost maturation. *Biological Wastes* 1990, 33, 251-261.

## **Development of solid manure technologies**

*Développement de technologies basées sur une gestion des déjections sous forme solide.*

**G. Meszaros.**

Hungarian Institute of Agricultural Engineering. Quality Testing Society p.u.  
Tessedik Su 4. H-2100 Gödöllo. HUNGARY.

### **Abstract**

*In Hungary there are a lot of problems caused by the huge amounts of slurry produced in large pig farms and partially in dairy cattle units. Development is needed to improve the applicability/effectiveness of solid manure technologies in animal keeping and to increase the proportion of good quality farmyard manure (FM) in the total production of animal waste.*

*The litter system have several well known advantages. Disadvantages of the system in the pig housing are the higher transportation and utilisation costs and the higher labour demand. The labour costs can be reduce using deep straw bedding system, which is widely spread in the keeping system of the dairy cows and beef cattle in Hungary. But the deep straw manure has poor quality, and the material costs are high because of the higher straw consumption To reduce the labour the bedding-slope floor system was adapted. The experimental barn has openings along the wall, the fattening pigs push the solid manure directly outside which is falling down to a longitudinal subsurface storage.*

*The first results of the system show :*

- *the labour required is reduced significantly,*
- *the consumption of straw is 50-70 % lower comparing to the conventional system.*

*The solid manure system is commonly used in the dairy cattle farming, mainly deep litter with straw. The problem is the lack of the correct storage facilities and the pure quality of the deep straw manure. We have planned a combined storage - maturing plant of solid and liquid manure.*

*It will also have facilities for composting of the manure surpluses. This demonstrational farm is situated on a water protected area.*

Keywords: Solid manure, pig keeping, dairy cattle, composting.

## Résumé

De nombreux problèmes se posent en Hongrie à cause des volumes considérables de lisiers de porcs produits en porcheries industrielles. Il est donc nécessaire de développer de nouvelles technologies de gestion sous forme solide de fumiers de bonne qualité.

Les systèmes sur litière présentent plusieurs avantages bien connus. Les inconvénients liés à ces systèmes sont la charge de travail. Le coût de la main d'oeuvre nécessaire peut être réduit en utilisant des litières profondes, ce qui est largement répandu en système bovin vaches laitières et bovin viande en Hongrie. Cependant, la litière profonde est de mauvaise qualité et les besoins importants en paille aggravent les coûts. Afin de réduire ces coûts, un système de litière inclinée a été développé. Le bâtiment expérimental est ouvert le long des parois, les porcs à l'engrais évacuent les déjections solides à l'extérieur et celles-ci sont collectées sur des aires de stockage.

Les premiers résultats témoignent que :

- le coût est réduit significativement,
- la consommation de paille est inférieure de 50 à 70% à celle du système conventionnel.

Dans le prolongement de ce travail, un système mixte de stockage-maturation des produits par compostage est prévu.

Mots-clés : déjections sous forme solide, élevage de porc, troupeau laitier, compostage.

## 1. Introduction

In the last decades - in the 60-s and 70-s - more large animal units was built in Hungary and in other Central and East European countries. These cattle and pig farms using "industrialised" closed production systems can work effectively and produce good quality food products, but they means heavy loading for the environment first of all because of the huge amount of manure. The waste management system must solve special problems from these units. The main problems by the system elements are as follows :

- Comfortable and labour save keeping technologies to have good production conditions for the animals.
- Mechanised or automatic systems for manure removal and transport to the storage. (At the big units there are good solutions only for the liquid manure systems).

- Safe storage to avoid harmful emissions (gases, odour, microorganisms) and to preserve nutrients during the required storage time (at least 3 months).

At the big units it needs huge and expensive storage facilities to store the manure. The slurry stores have big pollution potential if their storage's is broken. The reduction of the emissions is possible throw covering the storage, with needs extra investments.

At extreme huge units the amount of liquid manure do not make possible to store it during the required time. In this cage it must be cleaned and conducted to a recipient. This is possible only using more steps COD/BOD reduction techniques (phase separation, filtration, sedimentation or anaerobic/aerobic fermentation processes). The adaptation of the municipal waste water techniques do not gave acceptable results. The new requirements to conduct the waste waters to the surface waters cannot fulfil using these methods, that is why new developments are made to adapt low cost biological purification steps like wetlands.

Utilisation of manure in the coop production as a fertiliser in an environmentally friendly way counts the optimal way of the recycling of the nutrients, but it produce special problems, because of :

- the season for spreading the manure is limited
- the concentration of the nutrients in manure many cases is law
- the big plant needs huge acreage fields with different crops
- the big capacity machinery for transport and spreading is very expensive
- the organisation and the logistic system is complicated.

Because of the about mentioned characteristics, there is en need of new solutions to avoid the production of liquid manure using labour saving bedding systems.

## **2. Pig keeping technologies**

Owing to the favourable natural conditions animal husbandry and the pig production within it had always a great importance in the agricultural section in Hungary. As a result of a governmental programme for developing the pig production, increasing of the pig stock was considerable by the early '80-s. Nearly 290 of large-scale pig farms were completed by that time.

Twenty seven percent of these farms have 3,000 - 4,000 places for fattening pigs, while about 20 % of the total farms have 10,000 or more fattening places. At the same time the individual or private pig-keepers were predominant. Private farmers and individual pig keepers had more that 50 % of the total number of the sows.

Characteristics of the keeping technologies as follows :

Seventy eight percent of the pig houses built with part-slatted floors. Hydraulic manure removal systems were applied in 80 % of the breeding houses while in 87 % of the fattening ones. 45 % of the farms run without any slurry handling system. By the year of 1985 about 4,5 % of the pig farms had built-in mechanical manure removers. Rate of the pig farms using hydraulic manure removal technologies was 94 %.

Diluted slurry was irrigated on the surface of arable land around the farms in 54 %, while 40 % of the pig farms used slurry tankers. Volume of slurry was about 16 million m<sup>3</sup>.

Compared the data of the "top-period" of 1985-86 the pig production - was strongly reduced after the political-economical changes up to 40 % in 1994. In the last years goes slowly up again.

### **3. Fattening experiments on sloping floor with straw bedding**

We found, that development is needed to improve the applicability/effectiveness of solid manure technologies in animal keeping and to increase the proportion of good quality farmyard manure (FYM) in the total production of animal waste.

The litter system have several well known advantages :

- no slurry problem,
- higher level of thermal comfort and welfare of animals,
- lower odour emission, less stress for animals,
- utilisation of the cheap wheat straw produced by the crop production,
- the good quality FYM is an important source of organic carbon in the soils.

Disadvantages of the system in the pig housing are the higher transportation and utilisation costs and the higher labour demand.

The litter and labour saving pig fattening experiments were started at a private pig farm of Mr E. Tugyi, Újlengyel village, in the second half of August, 1997. The owner has 60 ha of arable land. On the 50 % of it he produces cereals (triticale); on 30 % maize, and on 12 % of it sunflower seeds.

Cereals are used for feeding fattening pigs. Weaning of the pigs take place after about 56 days at 15 kg live weight. Fattening lasts about 5 months. Fattenings at about 110 kg l.w. are slaughtered on a private slaughterhouse. Number of fattenings per year is about 500-550 head.

The experimental pens were constructed and built on the basis of the German experiences, taking into consideration the Hungarian conditions. In the same house there are two experimental pens with 15 places in each and one control pen with 30 places. Fattening in the experimental pens are fed from four combined self-feeders, while the stock of the control pen from traditional feeders.

Data Sheet is made to collect the results and experiences of the experiments.

First group of fattenings was ready by the middle of January, this year.

According to the first experiences, the average daily weight gain was about 800 g. Straw litter consumption will be about 0.1-0.2 kg/place, day that is favourable. Labour requirements take place only at filling up the feeders and the straw grid.

The experimental barn has openings along the wall, the fattening pigs push the solid manure directly outside which is falling down to a longitudinal subsurface storage. In this way the dosage, move, spread and removal of the bedding - manure mixture (solid farmyard manure) is made by the animals, without any labour consumption.

The capacity of the storage is about 1 m<sup>3</sup>/animal. It means, that the transport of the farmyard manure is needed only once in a month.

The diagram of the experimental barn is shown on the Fig. 1.

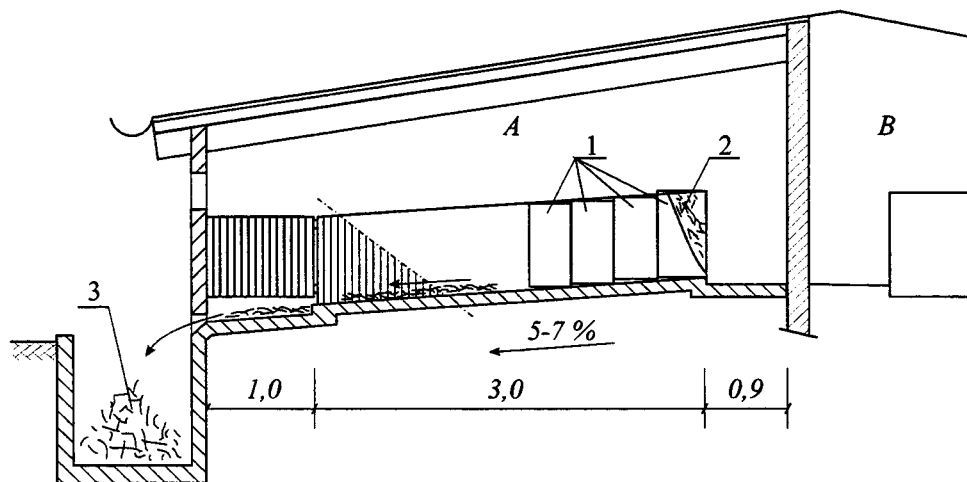

A. Experimental pens, B. Control pen.

1) Combined self feeders, 2) Straw guid, 3) Manure collecting pit.

*Figure 1*

*Constructing the experimental pens of sloping floor with straw bedding*



#### 4. Housing systems for dairy cows

In today's cattle husbandry, three main types of housing systems for dairy cows are distinguished: loose housing, tie stalls and free stalls. Table 1 gives an inventory of those housing systems, based upon their waste management characteristics.

Waste management characteristics				
Housing system	Collection system	Type of waste	Removal technique	Storage
Free stall with : * slatted floor	shallow pit	slurry	gravity/pump/tanker	outside
	deep pit	slurry	-	inside
* concrete floor	deep pit	slurry	-	inside
	non	slurry	flushing/scraping	outside
Loose	straw bed	manure + straw	hand; tractor	outside
	concrete floor	slurry	hand; tractor	outside
Tie stall	shallow gutter	* faeces +straw	hand; scraping	outside
	deep channel	* urine	gravity	in-/outside
		slurry	-	inside
		slurry	pump/tanker	outside

*Table 1  
Housing systems for dairy cows and its waste management characteristics.*

Nowadays, in Hungary most dairy farms have loose stall houses with wheat straw bedding. Storage is needed for storing the slurry produced in the milking house and from the waiting area, together with the washing water. From the farmyard manure storage comes out urine and polluted water which must be conducted to the storage too.

For the comfort and health of the animals very important the use of good stored, dry straw. The big proportion of the cereals in the plant production gives possibility for using bedding and recycling the organic material into the soil.

These systems are those in which manure can be collected, stored, transported, and utilised in a solid form. This necessitates scraping of the manure and minimising the quantity of the manure and minimising the quantity of water which comes into contact with it. In some climates it may require addition of other material to absorb moisture to get the manure into a solid form.

Floors or alleys can be scraped prior to flushing. The or alleys manure then is handled as a solid for spreading on cropland or for exporting from the farm. If dry scraping is used in conjunction with flushing, then size and cost of the spray field will be reduced. It is recommended that provision be made for dry scraping and flushing in the modification of existing facilities or in design of new facilities.

If export of the nutrients from a dairy is required, then composting can convert manure into a much less odorous and more acceptable material for spreading on cropland or for marketing to the public. Many owners/operators of large dairy farms are becoming interested in composting for 3 reasons: (1) it is a method of exporting nutrients from the farm and obtaining some economic return, (2) it eliminates or minimises the size of large spray fields and cropping systems, and (3) it gives a better form of fertiliser to use it in organic farming.

## **5. The Hungarian Project to Develop a Pilot Farm**

The dairy farm Matra near Batonyterenye (North East of the Capital) is located on a small river, the Zagyva, which is a branch of the river Tisza, that drains into the Danube. The Tisza basin area covers 40% of the Hungarian Republic territory. The farm is located near the boarder with Slovakia. It is one of the 150 dairy farms in the Tisza catchment area, which are of similar in size (200-400 animals). Because of its location and it represents an average farm, it is chosen as one of the focus points in the Strategic Action Plan for the Danube basin and has nationally a high priority and the government want to use it in future as a pilot-farm.

The cows are kept in a shed with an open system lay-out under deep litter regime. The stables are cleaned twice a year. The manure is taken out and put very near to the sheds.

The corridor to the feedline and the open space outside is cleaned once a week. The liquid manure is collected in 3 pits, pumped under vacuum to one tanker. Than it is spread regularly over nearby (situated 150 meter from the farm) grass-lands one flat of 30 hectares and 150 hectares of lands which have a slope.

When it rains, water leaks from these solid manure heaps and also from the barn and runs into to the nearby river.

The animals at the farm produce per year 3,000 tons of manure. This includes 240 tons of straw (2.6 Kg/day/animal).

1,100 tons of manure are produced during the grazing period, and about half of this remain in the fields.

Urine, annually in the fields 350 m<sup>3</sup> and at the farm 1,850 m<sup>3</sup>, of which 600 m<sup>3</sup> remain in the straw and 1,250 m<sup>3</sup> of the liquid flows into one of the three pits

From the milking parlour, there is an additional 3,000 m<sup>3</sup> of water per year used for cleaning, which goes into one of the pits.

## 6. The proposal

The farm agrees with the proposal which originates from the Ministry of Agriculture.

These investments total (counted on prices January 1997 and without tax ) 68 million HUF and they can be divided into the costs of building and construction, planning and technical supervising and machinery and equipment.

Constructions:

Five different constructions will have to be built.

- To store the solid manure, an open construction is required with an isolated floor of 20 meter by 50 meter and 2.5 meter high. The estimated total cost required for that investment is 10.0 Million HUF.
- For the storage of the liquid manure a concrete tank is required of 900 m<sup>3</sup>.

The estimated cost of that storage is 8.0 million HUF

- For one third of the solid manure a composting plant is required of 3.0 million HUF.
- For the storage of straw, needed for the deep litter, a building is needed of 18.0 million HUF
- Drainage system, for draining directly the rain which has fallen on the open space of the cows to convey it into the concrete tank. Total cost 4.5 million HUF

Machinery and Equipment :

The following machinery and kinds of equipment is needed for the handling of the manure.

- A straw bail opener and cutter of 1.6 million HUF
- Slurry mixer and pipes to transport the slurry from the pits to the liquid storage tank. 1.8 million HUF
- Compost mixer (tractor driven), 2.5 million HUF
- Pipes, tubes and pump to pump 50% of the liquid manure to the nearby fields. 2.7 million HUF
- To transport solid manure to the fields, 2 car and 1 self driven loader, 7.5 million HUF
- For the transport of the other 50% of the liquid manure on other fields two vacuum takers, 2.4 million HUF.
- Finally to decrease the water use, two washers, one for the milking equipment 1.4 million HUF and the second to clean the milk cooler, 0.5 million HUF.

## 7. Conclusions

The using of the bedding by the keeping of pig and dairy cattle has great importance in Hungary, because the most serious problems are originated from the large animal units, producing liquid manure.

The bedding on sloped floor by the pigs seems to be fruitful technology. The results of the system show :

- the labour required is reduced significantly,
- the consumption of straw is 50-70 % lower comparing to the conventional system.

The solid manure system is commonly used in the dairy cattle farming, mainly deep litter with straw. The problem is the lack of the correct storage facilities and the pure quality of the deep straw manure. We have planned a combined storage - maturing plant of solid and liquid manure.

It will also have facilities for composting of the manure surpluses. This demonstrational farm is situated on a water protected area.

The investments and running costs of the demonstration farm are high compared with the level of the profit achievable on dairy farms. It means that the state must subsidise the projects which are needed to solve the environmental problems on the existing farms. The new subsidising possibilities of the Agricultural Fund are open for this purpose first this year.

The Hungarian government is preparing now a new wider program in connection the Phare Program to help the animal farms in the environmental investments.

## 8. References:

1. **I. Fésűs; Gy. Mészáros:** Treatment and Disposal of Cattle Manure in Hungary Conference on Phare Danube Program, IASHI, Romania, September 1997.
2. **L. Mátyás; Gy. Mészáros; L. Fenyvesi:** Fattening experiments on sloping floor with straw bedding, 21st R+D Conference HAS, Gödöllő, 20-21 Jan. 1998.
3. **L. Mátyás; Gy. Mészáros; L. Fenyvesi:** Handling and utilisation of organic manure, Hungarian Agricultural Engineering 9/96.
4. **Gy. Mészáros:** Engineering aspects of waste management on large animal units, Proceedings of International Workshop on Environmentally Friendly Management of Farm Animal Waste Sapporo, 1997.



## **Landspreading of industrial wastes.**

*Epandage des déchets industriels.*

**R.D. Davis B.Sc., Ph.D., FCIWEM.** Principal Technical Specialist.  
Soil, Waste and Groundwater Group, WRc, Medmenham Laboratory,  
Marlow, Bucks. SL7 2HD, UK.  
e-mail: davis\_r@wrcplc.co.uk

### **Abstract**

*The legislative framework for waste management in the European Union together with the landfill tax, promote waste recovery by landspreading where this is environmentally acceptable. Landspreading can represent an economical and environmentally safe way to recover value from a variety of wastes such as farm slurries and manures, as well as a range of non-farm wastes such as sewage sludge and controlled industrial wastes. In the UK, The Waste Management Licensing Regulations (1994) exempt a number of wastes in the latter category for landspreading. This is in accordance with the principles of the 'Waste Framework Directive' 91/156/EEC amending 75/442/EEC. This legislation permits certain controlled industrial wastes to be spread on the land without a waste management licence although the Environment Agency (the UK regulatory authority) must be notified in advance of the proposed operation which must be carried out in a manner that is :*

- *demonstrably beneficial to agriculture or provides ecological improvement;*
- *consistent with the principles of sustainable development; and*
- *protects human health and the environment.*

*Much legislation and guidance already exists for the management on land of fertilisers, farm wastes and sewage sludge. WRc and ADAS have just completed for the UK Environment Agency, Department of the Environment, and Ministry of Agriculture, Fisheries and Food a guidance document which was intended to explain the criteria above in general and specific terms for the 13 categories of exempted wastes (Davis and Rudd 1998). This paper describes the principles of landspreading as a guide to regulators and operators to facilitate beneficial recycling of suitable wastes.*

*If landspreading of wastes is to be seen as acceptable recycling of secondary products as opposed to wastes, and is to be viable in the long-term as an economic outlet, then there needs to be investment in such aspects as quality control, treatment, storage and agricultural trials.*

Keywords : *Guidance, criteria, landspreading, industrial wastes*

## **Résumé**

Le cadre réglementaire de gestion des déchets dans l'Union Européenne, ainsi que la taxe sur les décharges, conduit au recyclage des déchets par épandage sur les terres. L'épandage présente en effet une approche économiquement rentable, sans risque pour l'environnement et une possibilité de valorisation d'un large panel de déchets tels que les lisiers et fumiers d'élevage, ainsi que des déchets non-agricoles tels que les boues de station d'épuration et des déchets industriels contrôlés.

Au Royaume-Uni, les réglementations autorisant la gestion des déchets (1994) excluent un certain nombre de déchets industriels de possibilité d'épandage.

Le centre de recherche sur l'eau (WRC) ainsi que le service de développement et conseil pour l'agriculture (ADAS) ont établi récemment à la demande de l'Agence pour l'Environnement, un guide qui explique les critères et les conditions spécifiques de 13 catégories de déchets.

Si l'épandage des déchets s'avère une approche acceptable de recyclage de produits dérivés et si cette approche apparaît viable sur le long terme, alors il faudra investir sur des aspects tels que le contrôle qualité, le traitement, le stockage ainsi que des essais en conditions de plein champ.

Mots-clés : recommandations, critères, épandages, déchets industriels.

## **1. Introduction**

The 'Waste Framework Directive' 91/156/EEC included the principle of the waste hierarchy which ranked the different waste management options in order of preference as :

- reduction;
- re-use;
- recovery- recycling, composting and energy; and
- disposal.

The broad waste recovery category at the third level incorporates materials recycling, composting and recovery of energy from waste. This is to indicate that no one of these should automatically be preferred to any other, as this will depend on the Best Practicable Environmental Option (BPEO) for a particular waste stream.

Landspreading can represent an economical and environmentally safe way to recover value from a variety of wastes, such as farm slurries and manures, as well as a range of non-farm wastes, such as sewage sludge, food processing wastes, lime and gypsum.

Potential advantages of landspreading include :

- recovers waste which in the past might have been dumped at sea or landfilled;
- replaces chemical fertilisers - a potentially more sustainable approach than reliance on continuous supplies of nitrogenous fertilisers from energy-intensive processes, and phosphate fertiliser and peat soil conditioners from finite sources;
- improves soil structure; and
- economic advantage in terms of savings on more expensive alternatives for both waste producer and farmer.

This paper describes some of the guidance developed in the UK, on behalf of the Department of the Environment, Transport and the Regions, Environment Agency and Ministry of Agriculture, Fisheries and Food, to enable landspreading of industrial wastes within the requirements of the Directive 91/156/EEC. Full details of the guidance are to be published shortly.

## **2. Principles of waste recycling to land**

Waste legislation in Europe is based on the Waste Framework Directive 75/442/EEC as amended by 91/156/EEC. Article 3 of this Directive encourages : the prevention or minimisation of waste; and secondly :

- the recovery of waste by means of recycling, re-use or reclamation or any other process with a view to extracting secondary raw materials; and
- the use of waste as a source of energy.

Article 4 requires Member States to take the necessary measures to ensure that waste is recovered or disposed of without endangering human health and without using processes or methods which could harm the environment, and in particular:

- without risk to water, air, soil and plants and animals;
- without causing a nuisance through noise or odours; and
- without adversely affecting the countryside or places of special interest.

Article 4 concludes by requiring Member States to take the necessary measures to prohibit the abandonment, dumping or uncontrolled disposal of wastes.

The Waste Framework Directive therefore sets out the basic rules for waste recovery.

In Annex IIB, it lists recovery operations as they are carried out in practice. It repeats at this point that, in accordance with Article 4, waste must be recovered without endangering human health and without the use of processes or methods likely to harm the environment. This further emphasises the importance that the Directive gives to protection of human health and the environment. One of the



operations which may lead to recovery listed in Annex IIB is number R10. This is, spreading on land resulting in benefit to agriculture or ecological improvement, including composting and other biological transformation processes, except in the case of waste excluded under Article 2 (1) (b) (iii) - animal carcasses and the following agricultural waste: faecal matter and other natural, non-dangerous substances used in farming. Benefit to agriculture and ecological improvement are not defined any further but need practical explanation in order to enable satisfactory implementation and development of recovery by recycling to land of suitable wastes. These terms are central to the acceptability of landspreading of industrial wastes. Following on from the definitions, it should be possible to decide whether agricultural benefit or ecological improvement would be achieved by a proposed landspreading operation on the basis of the properties of the waste, the quantity to be applied, method of application and location, and overriding need to protect human health and the environment.

### **3. Agricultural benefit**

#### **Where do the benefits apply, and what are they?**

This applies to agricultural and other land managed for profit which would normally receive applications of fertilisers and manures.

**Agricultural benefit will be achieved when the application of a waste to land improves soil conditions for crop growth whilst ensuring the protection of environmental quality in the broadest sense.**

The benefits can be measured in terms of :

- **Crop yield and quality.** The most important indicator of agricultural benefit to which the other benefits each make some contribution;
- **Soil chemical properties.** Benefits that the waste will bring to the soil in terms of addition of plant nutrients in particular, and improvements in soil pH value;
- **Soil physical properties.** Addition of organic matter; improvements in water holding capacity, porosity, stability, tilth, and workability. Addition of chemicals such as gypsum can also improve the workability of some soils;
- **Soil biological properties.** Addition of organic matter improves water retention and aeration, conditions for root growth and populations of worms and micro-organisms;
- **Soil water content.** Application of watery wastes can bring benefit when there is a soil moisture deficit limiting crop growth;
- **Land levelling.** The bulk application of waste to raise the level of the land can bring benefit by improving soil conditions for agricultural use. Simply raising the level of the land does not qualify, there has to be added benefit. Suitable waste for levelling would be waste soil or compost and dredgings from inland waters.

- These benefits must be achieved in compliance with Article 4 of the Waste Framework Directive 91/156/EEC. That is, without endangering human health and without using processes or methods which could harm the environment, and in particular:
  - without risk to water, air, soil and plants and animals;
  - without causing a nuisance through noise or odours; and
  - without adversely affecting the countryside or places of special interest.

## 4. Properties of wastes that can bring benefits

### Content of nutrients

The major nutrients are nitrogen, phosphorus, potassium and magnesium, calcium and sulphur. Information should be sought on the total concentration of nutrients in the waste and also on how much of the total content is soluble and therefore likely to be available for crop uptake in the same year in which the waste is applied to the land. At least part of the content of these elements supplied in wastes should be available, or become available, for plant uptake within three years provided this does not introduce deficiencies in the meantime. The rate of application of the waste to the land should be determined on the basis of the nutrient content of the waste and the nutrient requirements of the crop as defined in agricultural advisory information. Nutrient requirements, and hence rates of application, vary according to the type of crop, type of fertiliser material, time of application, type of soil and soil index. The latter is an estimate of the current nutrient content of the soil based on previous cropping history (for nitrogen) and soil analysis. For some nutrients, such as phosphorus, no further addition may be needed or justified if the index shows that adequate reserves are already in the soil. For most of the exempted wastes there is little or no evidence from field experience or trials with which to optimise rates of application to the land to meet crop requirements for nutrients. Until this information is available, 'properly qualified advice' PQA should be sought to estimate suitable rates of application to the land of those wastes whose intended agricultural benefit is to contribute to crop requirements for nutrients.

### Trace elements

Wastes may also provide the trace elements iron, manganese, copper, zinc, molybdenum, boron and chloride required by crops in small quantities.

### Organic matter

This will generally improve soil conditions for plant root growth, increase moisture-holding capacity and stabilise light soils. Instability of structure can develop when soil organic matter falls below 3% so for these soils in particular, application of organic matter is likely to bring agricultural benefit. For soils with an organic matter content of more than 5%, benefit will be confined mainly to the nutrients in the added organic matter. **Applications of organic matter of 20 t. (D.M. basis) ha<sup>-1</sup> y<sup>-1</sup> or more will be needed to improve soil conditions.** Organic matter contains

plant nutrients which will be of benefit to crop growth if they are released slowly into the soil as the organic matter stabilises. The plant nutrient content of organic wastes should be taken into account when estimating suitable rates of application to the land. Field trials are needed to test the availability of the nutrients in these wastes in order to justify the operational use of rates of application based on the organic matter content rather than the nutrient content of the wastes.

### **Lime potential**

This application would make use of the lime potential of a waste to raise the pH value of acid soils to a level more beneficial for crop growth. This will be of benefit only to acid soils with a lime requirement. The efficacy of a waste to satisfy the lime requirement of a soil is estimated on the basis of its neutralising value (NV). There may be occasional circumstances where an acidic waste, such as one rich in sulphur, could be used beneficially on the land to reduce soil pH value.

### **Chemistry that improves soil structure**

For example, gypsum (calcium sulphate) application to heavy land will make the soil more workable. Calcium and other soluble sulphates can also be beneficial in the reclamation of saline and alkaline soils.

### **Soil forming properties**

Soil forming properties for land levelling as described above. The only types of waste suitable for this purpose are likely to be waste soil or compost and dredgings from inland waters.

### **Irrigation**

Use of watery wastes for irrigation. This will be of benefit only at times of the year when there is a soil moisture deficit.

## **5. Properties of wastes that can bring disbenefits**

### **Content of nutrients**

This can be a constraint because content of nutrients will often be the factor limiting quantities of waste that can be applied to the land. Rates of application need to be based on crop requirements as set out in fertiliser recommendations to obtain a beneficial crop response and protect water quality.

### **Content of potentially toxic contaminants**

Various contaminants may occur according to the type of waste and the process which produced it. Those monitored in sewage sludge spread on the land are a starting point as to what to consider monitoring in other wastes and include: cadmium, copper, nickel, zinc, mercury, lead, chromium, arsenic, selenium, molybdenum and fluoride. All of these will accumulate in top soil so their concentration in soil will increase progressively following repeated applications of

wastes that contain them. Guidance on this subject in terms of permissible limits and monitoring requirements are described in the 'sewage sludge to land' Directive 86/278/EEC. Using the information in the Directive and the known concentration of contaminant in the waste, a permissible maximum rate of application of the waste to land can be calculated based on contaminant content. This can then be compared with the maximum permissible rate of application based on the nutrient content of the waste. If contaminant content would be the principal limiting factor determining the rate of application of a waste to land then agricultural benefit would not be achieved.

Vigilance is needed also to be aware of other contaminants, including toxic organic compounds, which could be present in some wastes according to their origin. If information is lacking and their presence in a waste is suspected then PQA should be sought before any decision is taken about landspreading.

#### **Excessive acidity or alkalinity**

A waste with a pH value of <5.0 should not be applied to the land. Alkaline wastes should only be applied to soils with a lime requirement.

#### **Sodium content and conductivity**

Although sodium enhances the growth of some crops excessive amounts can adversely affect soil structure and crop growth as can excess salinity from other soluble salts. These parameters should be measured in wastes and the findings checked against recommended limits.

#### **Smell**

Wastes with strong or offensive odours should either be treated by a stabilisation process, such as anaerobic digestion or composting, which will reduce their odour potential, or otherwise managed on the land so that odour emission is minimised. In practical terms this means that odorous wastes should be applied to the land by subsurface soil injection or incorporated (ploughed in) immediately after surface application.

#### **Visual appearance including colour and litter content**

This is likely to be a potential problem with septic tank waste, paper sludges and some food and other wastes which may contain strong dyes. Wastes such as septic tank sludge which may contain litter, including non-degradable plastics, should be screened to remove it before landspreading.

#### **Microbiological quality; content of human, animal and plant pathogens**

The UK Department of the Environment (DETR) Code of Good Practice for the Agricultural Use of Sewage Sludge (1996) provides guidance on how to prevent disease transmission when wastes potentially containing pathogens are used on the land. A dual barrier approach has been adopted based on treatment of sludge to reduce the numbers and infectivity of pathogens combined with land management practices to be followed according to whether or not the sludge has

been treated. There has been no recorded incident of disease transmission where these precautions have been followed. Untreated sludges have to be applied to the land by subsurface soil injection or otherwise worked into the soil so as not to cause nuisance. It should be noted that for these purposes septic tank sludge is untreated sludge and must therefore be injected or ploughed into the soil and must not be applied to the surface of grassland.

Operators need to be fully advised of the nature of wastes they are handling, made aware of precautions they should be taking, and equipped with the necessary protective clothing and facilities.

Diseased plant waste should not be spread on agricultural land.

### **Texture and handleability**

Operational problems may arise from, for instance, wastes which are dusty or gelatinous or oily and greasy in texture. Dust may be hazardous to operators or cause nuisance when the waste is spread on the land. Gelatinous or greasy wastes may block spreading equipment and remain as an unsightly residue on the surface of the soil or cause anaerobicity in the soil if excessive amounts are ploughed in. Smothering of grass which has received surface applications may occur and can cause die-back due to light exclusion.

### **High carbon/ nitrogen ratio**

High carbon/nitrogen ratio. This is a problem likely to be associated with organic wastes from wood, paper or sugar production. The cells of soil bacteria have a C/N ratio of about 10/1. Nitrogen is the limiting factor to degradation by bacteria in the soil of wastes with a C/N of >10/1. As they degrade such wastes, the bacteria will draw on soil reserves of nitrogen which could otherwise be used by crop plants. In reality, this problem is unlikely to occur until the C/N ratio of the waste exceeds at least 20/1. Application of such wastes can immobilise soil nitrogen supplies thereby inducing nitrogen deficiency and reduced yields of crops. The C/N ratio of the waste can be adjusted to make it more favourable for landspreading by composting it or adding a source of nitrogen.

### **Biological oxygen demand (BOD)**

Organic wastes are very likely to have a high BOD, often at the level of 1000 mg l<sup>-1</sup>. Such wastes will be highly polluting if they contaminate water and care must be taken to prevent runoff or spillage into surface water in particular. Operational experience with sewage sludge has shown that soils can satisfactorily stabilise wastes high in BOD but there is some risk of anaerobicity if rates of application are excessive.

## **6. Management factors that influence agricultural benefit and disbenefit**

Management can make all the difference between a successful and disastrous landspreading operation. Consequently, consideration should be given to authorising operators for landspreading, on the basis of suitable qualifications and experience, as an alternative to exempting individual operations. Management factors are discussed in more detail in Section 9 on best practice. Some factors to consider are:

### **Risk assessment**

The need to do a risk assessment for the proposed operation. This should take the form of three phases:

1. Is the waste of a generic type capable of providing agricultural benefit or ecological improvement?
2. Bearing in mind the type of waste, what further information should be provided concerning chemical analysis etc. of the actual sample of waste to be spread on land in the proposed operation? In the light of this information, is the operation still permissible?
3. On the basis of inspection of the proposed landspreading site, what special precautions are required to ensure compliance with Article 4 of the Waste Framework Directive 91/156/EEC concerning protection of human health and the environment?
- 4.

### **Land use and management**

This must be taken into account for determining rates of application of wastes to the land on the basis of fertiliser recommendations and, for wastes containing pathogens, actions to prevent disease transmission (UK DETR Code of Practice for the Agricultural Use of Sludge, 1996).

### **Topography of the site**

This would include type of soil, drainage, slope, occurrence of ditches and watercourses, and access for vehicles. This information is needed to protect water quality. It is also necessary for planning to avoid damage and nuisance from vehicles to be used in the operation.

### **Time, method and rate of application**

This needs to be considered to protect surface and groundwater quality and to avoid odour nuisance and pathogen transmission (UK DETR Code 1996). There will be times in the winter when waste cannot be spread due to the unacceptable risk of soil damage or leaching/runoff of nutrients. Farmers have had to install storage facilities for their slurry and other liquid wastes to avoid the need for landspreading at inappropriate times of the year; waste producers using the landspreading option should be prepared to do likewise. Failure to do so may lead to the operation being regarded as disposal.

### **Quality and consistency of waste product**

Agricultural benefit depends largely on suitable rates of application of waste calculated to deliver to the land the right amount of plant nutrients or other beneficial components to meet crop and soil requirements. This can only be done if the waste in question is of consistent quality particularly in terms of its properties which may influence agricultural benefit or disbenefit. The onus should be on the waste producer to demonstrate by statistically based sampling and analysis that the waste product for landspreading will be of suitable quality to achieve the agricultural benefit for which it is intended.

### **Notification, consultation, monitoring and record keeping**

The waste producer or spreader should notify the environmental protection authority of proposed landspreading operations and provide the information necessary for the authority to decide whether or not the proposed operation will achieve agricultural benefit or ecological improvement. The authority can then decide whether or not to authorise the operation. PQA should be considered to assist with deciding on suitable rates of application of waste and other operational matters. Appropriate monitoring and analysis of waste product (to check its quality) and soil from the receiving farmland will be needed. Records should be kept of the farm location and details of the waste type, quality and rate of application.

## **7. Ecological improvement**

### **Where is it achieved?**

Demonstrating potential for ecological improvement where wastes are to be spread on the land is very much associated with identifying those managed environments (beyond designated agricultural land) which will benefit from inputs of nutrients, organic matter or other beneficial component of the waste. Also central to identifying sites where landspreading of wastes could bring ecological improvement is Article 4 of the Waste Framework Directive 91/156/EEC with its concern for the protection of human health and the environment, and in particular the requirement that waste is to be recovered 'without adversely affecting the countryside or places of special interest'.

**Ecological improvement is associated with the maintenance of habitats and their biodiversity where these would otherwise deteriorate, the provision of new habitats for wildlife and the development or restoration of existing habitats to give greater biodiversity and sustainability.**

In terrestrial ecosystems, species-rich habitats of high ecological value tend to have a finely balanced nutrient budget on which their biodiversity depends. Examples of habitats of high ecological and nature conservation value include chalk grassland, flower-rich meadows and mixed woodland, but this is not an exclusive list. The

addition of nutrients, organic matter and other constituents in applications of waste, albeit of benefit for agriculture, would upset this fragile balance and lead to reduced biodiversity and loss of ecological value.

**Whilst agricultural benefit from landspreading of wastes can readily be demonstrated there will be comparatively few instances where landspreading of wastes can be justified on the basis of ecological improvement. In this sense at least, agricultural benefit is more important than ecological improvement as a justification for landspreading of wastes.**

Ecological improvement in the context of landspreading is confined to managed environments associated with planned soil improvement. These will be sites where the application of fertiliser/soil conditioner is considered essential for the planned land use which would not be possible without it. For example, restoration of soil of poor structure and nutrient status on land destined for agricultural or amenity use, and on derelict land resulting from human activities, e.g. mining and mineral exploitation, for the purpose of landscaping, amenity development or agriculture. In these cases landspreading can meet the criterion of ecological improvement by providing new habitats or improving the status of existing ones. However, each case must be taken on its merits as, for example, some derelict land is of nature conservation value due to the specialised habitats that can be found in such sites and thus would not benefit from improvement.

Landspreading in commercial forest land managed for timber production can also be acceptable and associated with a combination of benefit to timber production, from increased tree growth, and ecological improvement of the biomass and species diversity of the ground cover. Soils under coniferous forest are often of low nutrient status which limits tree growth unless fertiliser can be applied with phosphate being particularly beneficial. Utilisation of sewage sludge on forest land is well-established and the experience gained provides a basis for using other wastes for this purpose. Guidance is given in 'A manual of good practice for the use of sewage sludge in forestry' (UK Forestry Commission Bulletin 107, 1992). Landspreading of wastes would not be acceptable in many areas of forest and woodland because of the sensitive ecosystem, recreational value and public access. Proposals would need to be considered on a site-by-site basis.

It has been widely demonstrated that the reclamation or improvement of land is greatly improved by the addition of bulky organic manures and wastes (e.g. Wolstenholme and Hall 1996). Soils on such sites are often very deficient in organic matter and nutrients, and the use of wastes can achieve ecological benefit through improving soil conditions, enhancing plant establishment and generally providing long-term mitigation of the environmental impacts of derelict land sites, at reasonable cost. To achieve these benefits, the wastes may need to be applied at higher rates than for agricultural soils, and this may for instance result in soil concentrations of contaminants in excess of the limit values for agricultural soils.



PQA may be necessary to decide on whether the balance of such potential benefits and disbenefits of waste use constitutes ecological improvement on a site-by-site basis. Consideration would have to be given to other remediation options or the lack of them, and the continuing or likely adverse environmental, health or visual impacts if no remediation was carried out.

## **8. Deciding on whether a proposed landspreading operation will achieve agricultural benefit or ecological improvement.**

This section discusses the basis for a sound but practical and straightforward factsheet for the purpose of deciding whether or not a proposed waste landspreading operation will achieve agricultural benefit or ecological improvement. It should be the responsibility of the waste producer to supply the necessary information for the factsheet and to ensure that it is correct, and this responsibility should remain with the waste producer even if a contractor is used to supply the information. The regulator (the Agency) would use the completed factsheet to decide whether the proposed operation will achieve agricultural benefit or ecological improvement (see also Appendices A and B).

The questions to be completed in providing the necessary information for the factsheet are set out below together with guidance notes of explanation.

### **Type of waste from those listed as being potentially suitable for landspreading.**

**In the UK these are :**

Waste soil or compost.

Waste wood, bark or other plant matter.

Waste food, drink or materials used in or resulting from the preparation of food or drink.

Blood and gut contents from abattoirs.

Waste lime.

Lime sludge from cement manufacture or gas processing.

Waste gypsum.

Paper waste sludge, waste paper and de-inked paper pulp.

Dredgings from any inland waters.

Textile waste.

Septic tank sludge.

Sludge from biological treatment plants.

Waste hair and effluent treatment sludge from a tannery

**Benefits intended from its application to land**

*One or more of the following should be confirmed.*

Crop yield and quality

*(To demonstrate agricultural benefit a **yes** reply will almost always be required here)*

Soil chemical properties

Soil physical properties

Soil biological properties

Soil water content

Land levelling

**The properties of waste associated with benefit**

*These should be listed according to the benefit the landspreading operation is intended to bring. Section 8 and Appendix D will indicate to the Regulator which parameters to insist on for particular types of waste. Usually, only some of the parameters will be needed.*

*Analytical results are to be supplied as required for the determinands listed.*

Crop yield and quality - concentrations (dry matter basis) of plant nutrients in the waste: N, P, K, Mg, Ca, S and trace elements to be specified.

Soil chemical properties - dry solids content and neutralising value (NV) of the waste

Soil physical properties - organic matter and calcium sulphate content of the waste

Soil biological properties - organic matter content of the waste

Soil water content- water, conductivity and soluble salt content of the waste

Land levelling- stability of the waste

*(Likely to be confined to waste soil and compost, and dredgings from inland waters)*

Quality - is the waste of consistent quality? If so, how was this checked and how frequently?

*(Consistent quality of product is needed to achieve agricultural benefit or ecological improvement. The statistical basis for the stated waste quality should be described)*

**The properties of waste associated with disbenefit**

*Details of only some of these determinands will be required for each waste according to the guidance in Section 8.*

Contaminants - concentrations ( $\text{mg kg}^{-1}$  ds basis) in the waste of potentially toxic elements and persistent organic compounds where the origin of the waste indicates their possible presence.

*(See Section 8, Appendix D and the DoE Code of Practice for the Agricultural Use of Sewage Sludge (1996) for details of contaminants that should be determined for particular wastes)*

pH value of the waste.

Conductivity and content of sodium and soluble salts.

C/N ratio of the waste, ds basis

BOD

Oil and fat content

Microbiological quality

*(Does the waste contain human, animal or plant pathogens. If so, which and in what numbers?)*

Odour potential

*(Is the waste smelly or not?)*

Litter content

*(Has the waste been screened to remove litter or not?)*

**Site factors**

*The final source of information needed to make the assessment of whether or not agricultural benefit or ecological improvement will result from the proposed landspreading of waste operation.*

Location of site

Landowner agreement

*(Obtained or not?)*

Does it include, or is it part of, a designated site (biological or heritage)?  
*(If it does, landspreading will probably not achieve ecological improvement and not be acceptable)*

If so, what is the designation?

Specify existing land use

*(Agriculture (arable or grassland), reclamation etc.)*

List details of soil texture, soil nutrient indices, pH value and lime requirement

Proposed rate of application and how this is expected to achieve agricultural benefit or ecological improvement

*(Typically, this will have been derived for the crop to be grown according to fertiliser recommendations and soil conditioning benefit, taking account of the need to protect water quality.*

Has PQA been given, if so supply details including name and address of adviser?

Time and method of application

Will the operation adversely affect the countryside or places of special interest by damage to visual quality or amenity and landscape value?

*(Construction or widening of roads, destruction of walls or hedges or trees and destruction and widening of gateways may adversely affect the countryside)*

Arrangements for storage of waste

What monitoring of the operation is to be done?

What is the principal factor limiting the rate of application of waste to the land?

*(If this is content of contaminants or other negative factor, then agricultural benefit or ecological improvement will not be achieved. )*

What additional steps will be taken to ensure that agricultural benefit or ecological improvement will be obtained without endangering human health and without using processes or methods which could harm the environment, and in particular:

- without risk to water, air, soil and plants and animals;
- without causing a nuisance through noise or odours;
- without adversely affecting the countryside or places of special interest?

*(A reminder to the waste producer of statutory obligations)*

## 9. Conclusions

The 'Waste Framework Directive' 91/156/EEC requires that waste recycling to land must achieve agricultural benefit or ecological improvement. These terms have now been defined to provide the basis for guidance to facilitate the recycling to land of suitable industrial waste materials.

## 10. References

**CEC: Council of the European Communities** (1991) Council Directive amending Directive 75/442/EEC on waste. 91/156/EEC. Official Journal of the European Communities 26.3.91 No L 78/32-37.

**CEC: Council of the European Communities** (1986) Council Directive on the protection of the environment, and in particular of the soil, when sewage sludge is used in agriculture. 86/278/EEC. Official Journal of the European Communities 4.7.86 No L181/6-12.

**Davis, R. D. and Rudd, C.** (1998) Investigation of the criteria for, and guidance on, the landspreading of industrial wastes. Report 4088/7 WRc Medmenham, UK, SL7 2HD.

SI: Statutory Instruments UK (1994) The Waste Management Licensing Regulations. SI 1056. HMSO, London.

**UK Department of the Environment DETR** (1996) Code of Practice for Agricultural Use of Sewage Sludge. Publications Sales Unit, Ruislip, UK, HA4 8SF.

**UK Forestry Commission** (1992) Bulletin 107. A manual of good practice for the use of sewage sludge in forestry. HMSO. London.

**Wolstenholme R and Hall J.E.** (1996). The use of sewage sludge in land reclamation. A summary of experiences from published sources. Report UC 2774. Wrc, Medmenham, UK.

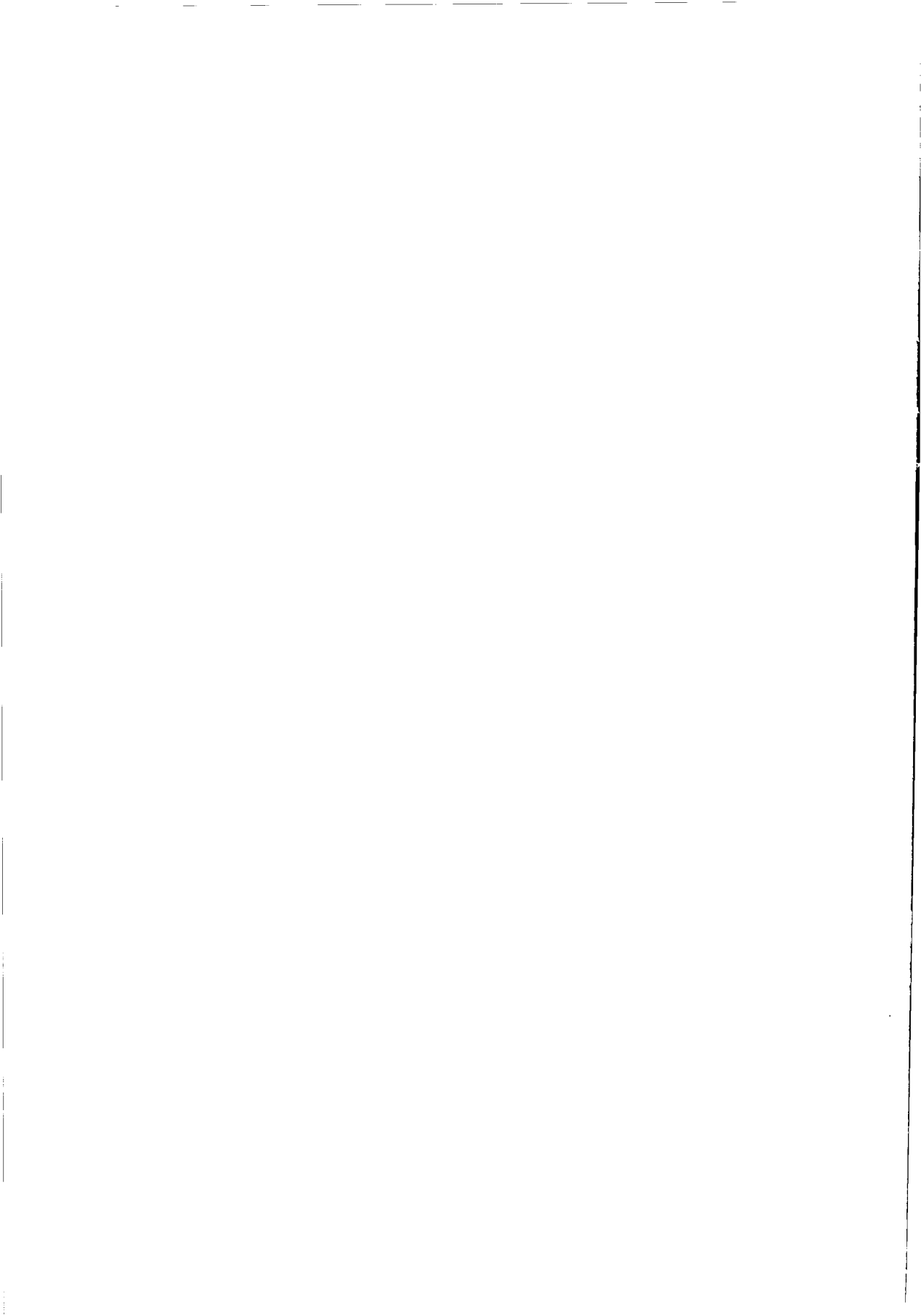

**Chairman's summary of part 2.**  
**Agronomic value of organic wastes**  
**William MAGETTE.**

This session consisted of 11 papers. Fardeau set the theme of the session by describing the historical basis for the application of organic wastes to land and emphasising that the land must not be viewed as a disposal site for wastes. Rather, waste utilisation and treatment should be the objective. To achieve this, it is essential to understand the crop availability of nutrients in wastes both immediately and in the long term. Fardeau stated that isotopic labelling of nutrients in wastes was an effective tool for determining the crop availability of the nutrients in organic wastes.

Williams *et al* reported their work in the UK to describe the mineralisation rates of nitrogen in various animal wastes. The mineralisation of N from layer manure and pig slurry (ca. 40% of applied N over 10 months) was significantly greater than that from cattle slurry (ca. 10%). Predictions from mathematical models to describe the mineralisation process were sometimes in error by ca. 100%.

Morvan and Leterme described their examination of carbon and nitrogen transformations resulting from pig and cattle slurry application. In laboratory studies they found both processes to be influenced greatly by soil conditions and were able to construct simple models to describe the process.

Lorenz *et al* told about their studies of solid animal manures. They demonstrated an inverse relationship between yield increases resulting from use of solid animal wastes and the C:N of the wastes. They also showed that application of wastes in the spring was more agronomically and environmentally beneficial than autumn applications. Manure applications in the autumn (in Germany) resulted in increased mineral soil N, suggesting increased leaching potential.

Klir *et al* reported the positive agronomic results of applying animal manures, sewage sludge and a biofertiliser in the Czech Republic. On clay loam and loam soils they showed the crop efficiency of N from pig slurry to be essentially equivalent to commercial fertiliser N. They described many soil characteristics improved by the addition of a biofertiliser made from a pig slurry substrate and produced in a pelletised form.

Balsari and Airoidi described their development of a 2-phase composting process suitable for transforming a liquid manure such as pig slurry into an easily managed solid product (26% DM). Their process was cost effective, easily operated, and relatively rapid.

Sommer *et al* reported their analysis of gaseous nitrogen, carbon dioxide and methane losses from deep litter from cattle houses. They showed that ammonia emissions can increase if litter is compressed or turned and mixed, compared to

litter which was not manipulated. Their results demonstrated the influence of waste handling practices on the nutrient value of the waste.

Bernal *et al* also reported the influence that composting has on the nutrient content of the final product. They reported that it is possible to manage the composting process in a way to optimise nitrogen content and to assure that the nitrogen is readily available for crop use.

De Guardia *et al* emphasised the importance of understanding the nature of the transformation processes that control nutrient forms and masses during composting of wastes. They presented a procedure by which data to characterise the composting process can be obtained and analysed to produce management guidance.

Meszaros described the benefits of using litter-based manure management systems in Hungary. To ameliorate the increased labour requirements associated with dry manure systems, a self-cleaning floor and bedding system was developed that also had the beneficial effect of reducing the amount of straw needed.

Davis presented a very appropriate conclusion to the session by re-emphasising the critical importance of viewing the landspreading of wastes as a recycling / treatment process and not a disposal operation. In discussing the application of industrial wastes to land, he stressed the necessity of quality control in all aspects of waste handling and the need for agronomic research to establish the nutrient value and pollution potential of non-agricultural wastes applied to land.

## **Part 3**

### **Measurement, modelling and control of gaseous emissions.**

**Chairman : S.G. Sommer (Denmark)**





# Gaseous pollutants from organic waste use in agriculture

## *Invited Paper*

*Polluants gazeux liés à l'utilisation agricole de déchets organiques.*

### **Brian Pain**

Institute of Grassland and Environmental Research.

North Wyke, Okehampton, Devon, EX20 2SB, UK.

E-mail : brian.pain@bbsrc.ac.uk

### **Abstract**

*Manures from housed livestock, sewage sludges and other organic industrial wastes are commonly applied to agricultural land to exploit their value as fertilisers or for disposal. Emissions of environmentally important gases and volatile compounds may arise either directly from the organic materials or from perturbations of soil processes. The gases of greatest concern include ammonia (NH<sub>3</sub>), nitrous oxide (N<sub>2</sub>O), other oxides of nitrogen (NO<sub>x</sub>) and methane (CH<sub>4</sub>). Although certain volatile organic compounds (VOC) have an impact on atmospheric chemistry, those responsible for offensive odours from wastes have received most attention. The focus of research has been on manures from housed livestock because the amounts applied to land far exceed those of other organic wastes. This paper outlines the processes which result in the formation and release of gaseous pollutants, the contribution of organic wastes, the main factors influencing emissions and techniques for abatement.*

### **Résumé**

Les déjections animales issues de bâtiments d'élevage, les boues et autres déchets organiques industriels sont habituellement épandus en agriculture, à la fois pour une valorisation de leur potentiel fertilisant ou comme méthode d'élimination.

Des émissions indésirables pour l'environnement de composés gazeux et volatils peuvent intervenir, soit directement à partir de ces déchets organiques ou à la suite de perturbations des processus intervenant dans le sol.

Les gaz les plus concernés sont l'ammoniac (NH<sub>3</sub>), le protoxyde d'azote (N<sub>2</sub>O) et autres oxydes d'azote (NO<sub>x</sub>) et le méthane (CH<sub>4</sub>). Bien que certains composés organiques volatils (COV) présentent un impact sur la chimie de l'atmosphère, ce sont les composés malodorants qui ont été les plus étudiés.

Les recherches se sont principalement développées sur les déjections animales produites en élevage intensif car les volumes apportés au sol dépassent largement ceux représentés par les autres types de déchets organiques.

Cet article présente un aperçu des processus qui engendrent la formation et l'émission de ces polluants gazeux, la contribution des déchets organiques, ainsi que les principaux facteurs influençant ces émissions et les techniques de réduction qu'il est possible d'envisager.

## 1. Ammonia

Following transport away from the source and deposition as ammonia gas ( $\text{NH}_3^0$ ) or ammonium salts ( $\text{NH}_4^+$ ), ammonia can have severe effects on sensitive ecosystems through direct toxicity to plants, nitrogen enrichment or eutrophication and soil acidification. Currently, there are negotiations within the EU which may give rise to controls over ammonia emissions from agriculture. Such controls already apply in some countries, particularly in the Netherlands.

### Sources of ammonia.

Most of the ammonia emitted to the atmosphere is derived from the hydrolysis of urea (Equations 1 and 2)

### Urea hydrolysis

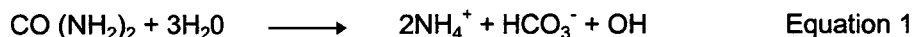

### Volatilisation

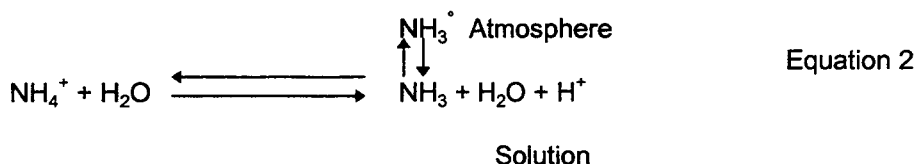

Livestock production is the major source of this gas with emissions occurring from manure in livestock buildings, in stores and from spreading on land. Grazing animals, nitrogen fertilisers, especially urea, and sewage sludges are smaller sources. (Table 1) (ECETOC, 1994).

	% total NH <sub>3</sub> -N
Livestock	
housing	34.5
manure spreading	31.5
grazing	7.7
Fertiliser application	12.2
Crops	5.6
Industry	0.5
Miscellaneous	8.0

*Table 1*  
*Anthropogenic contributions to ammonia emissions in western Europe*

Of all livestock classes, cattle are the largest source of ammonia. The importance of housing and landspreading manure is further emphasised by the estimates of ammonia emission from a dairy cow that are given in Table 2. This is based mainly on measurements made in the UK and also summarises the management options that are likely to influence emissions. (Pain, et al. 1989).

Annual emission in kg ammonia-N/animal

HOUSE	YARD	STORE	MANURE		GRAZING	TOTAL
7.0	2.4	3.3	LAND		2.4	23.9
			8.8			
OPTIONS:-						
Cubicles		Slurry :				
Straw bedded		Tanks	DM content		N fertilizer	
		Lagoons			use	
			Grass or arable			
			Time of year			
			Method			
		FYM :				
		Concrete pad	Grass or arable			
		Field heap				
		Dirty water				

*Table 2*  
*Estimate of ammonia emission from dairy cow management.*

### Factors influencing ammonia emission.

Although the process of ammonia volatilisation is well understood chemically and described by equations 1 and 2, the rate and extent of emission from organic wastes is influenced by the wide range of factors summarised in Table 3. Thus, in practice, the process is very complex and mathematical models are being developed to describe the process or to predict the rate and extent of loss for given sets of circumstances (Hutchings, et al., 1996; Genermont & Cellier, 1997).

<b>WASTE PROPERTIES</b> Dry matter content NH <sub>4</sub> -N content pH	<b>WEATHER</b> Solar radiation Temperature Rainfall Wind speed
<b>SOIL</b> Porosity CEC Vegetation pH	<b>MANAGEMENT</b> Application rate Application method Waste treatment

*Table 3  
Some factors influencing ammonia emission from organic wastes.*

The factors listed in Table 3 relate mainly to emissions following the application of manures or sewage sludges to land but some, such as wastes composition and weather, will also have an impact on emissions from animal housing and manure stores. Following application to land, the rate of ammonia emission is high for a few hours but rapidly declines to much lower levels which may continue for several days. Over 60% of the NH<sub>4</sub><sup>+</sup>-N, or plant available N, can be lost from livestock slurries (Pain, et al. 1989) or liquid sewage sludges (Beauchamp, et al. 1978) with most of this loss occurring within a few hours of application. In addition to environmental effects, ammonia emission also decreases the fertiliser value of manures. Losses from solid manures, such as those produced from loose housed cattle on straw bedding, are generally lower but continue for a longer time. Large losses can occur during composting of these materials (Amon, et al. 1998). The dry matter (DM) content of slurries has a large effect on emissions from landspreading with losses decreasing with decreasing DM content. (Sommer and Olesen 1991; Smith and Chambers 1995) (Fig 1). This is because more dilute materials infiltrate into the soil more rapidly which results in the cessation of ammonia volatilisation. Temperature and wind speed also have an important influence with warm, drying conditions in summer favouring high rates of emission.

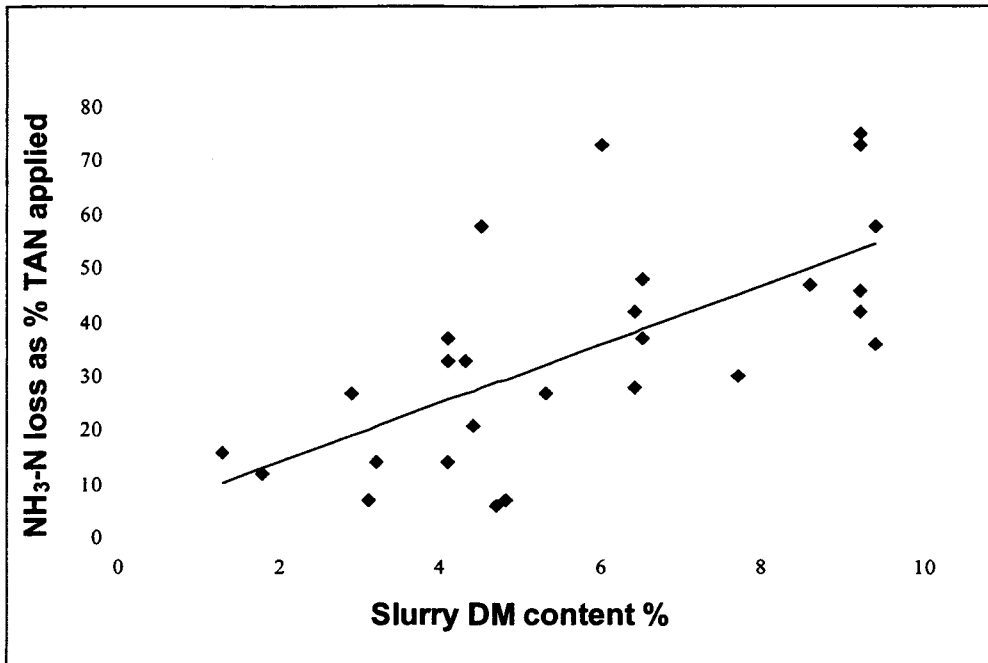

*Figure 1*  
*The relationship between ammonia loss and slurry dry matter content*

## 2. Nitrous oxide

Nitrous oxide strongly absorbs radiation in the infra-red band in the atmosphere and so contributes to the greenhouse effect and there is evidence that atmospheric concentrations are increasing.

### Sources of nitrous oxide.

Nitrous oxide is produced by the of burning biomass and fossil fuels and, more importantly in the context of this paper, from soil microbial processes. The gas may be released as a by-product during nitrification of  $\text{NH}_4^+\text{-N}$  and, more significantly, from incomplete denitrification of nitrates ( $\text{NO}_3^-$ ). (Equation 3 and 4).

### Nitrification

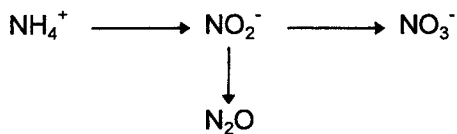

Equation 3

### Denitrification

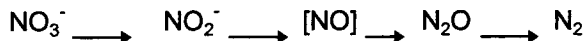

Equation 4

Agriculture and related land-based activities are, therefore, important sources particularly where large amounts of inorganic or organic fertilisers are used (see Table 4) (Grosslinger et al. 1996)

	% total N <sub>2</sub> O
Agriculture, forestry and land use change	47
Production processes	31
Combustion	13
Road transport	6
Other industry	3

Table 4

*Anthropogenic contributions to nitrous oxide emissions in EU 15 countries.*

The inventories of nitrous oxide emission for the UK and the Netherlands presented in Tables 5 and 6 illustrate the significant contributions that arise from manure management. The data for the UK (Chadwick, et al.) is for farmed livestock but includes fertilisers whilst that for the Netherlands (Kroeze, 1995) is more broadly based and also includes nitrous oxide emissions arising from the subsequent denitrification of losses via other pathways such as nitrate leaching.

	% total N <sub>2</sub> O
Livestock	
housing	22.5
manure storage	31.0
manure spreading	6.1
outdoor (incl. grazing)	11.0
Fertilizers	29.4

Table 5

*Contributions to nitrous oxide emissions from farmed livestock in the UK*

	% total N <sub>2</sub> O
Livestock housing	3.0
manure spreading	32.0
Fertilizers	26.0
Enhanced background	17.8
N losses	21.2

*Table 6*  
*Contributions of nitrous oxide emissions from agriculture in the Netherlands*

### Factors influencing nitrous oxide emissions

Livestock manure and sewage sludges provide a suitable source of nitrogen (NH<sub>4</sub><sup>+</sup>-N) for nitrification but, since they are mostly anaerobic, may temporarily inhibit this aerobic process. The provision of nitrifiable nitrogen together with a freely available carbon (C) source and moisture favours denitrification. Data on the impact of these materials on nitrous oxide emissions from land is limited but is likely to be influenced, amongst other factors, by differences in the composition of wastes as illustrated by the data in Table 7 (Chadwick et al. 1998; Mosier, et al. 1982). Nitrous oxide emission is also mediated by soil type and conditions

	g N <sub>2</sub> O/t
Pig slurry	34.8
Cattle slurry	12.6
Cattle FYM	21.7
Poultry manure	29.0
Digested sewage sludge	23.5

*Table 7*  
*Nitrous oxide emissions following application of livestock manures and sewage sludge to land*

### NO<sub>x</sub>

NO<sub>x</sub> denotes nitric oxide (NO) and nitrogen dioxide (NO<sub>2</sub>). The conversion of NO to NO<sub>2</sub> in the lower atmosphere is the primary source of ozone which is deleterious to air quality. These chemically reactive gases are also involved in reactions in the stratosphere which erode the efficiency of the ozone layer as a protective shield against ultra violet radiation. They are also implicated in acid rain.

### Sources of NO<sub>x</sub>

The primary sources of NO<sub>x</sub> are combustion of fossil fuels, biomass burning, lightning and the soil processes outlined for nitrous oxide. (Table 8) (Lee, et al. 1997).



	% total
Fossil fuel combustion	49.7
Biomass burning	17.9
Soil microbial processes	15.8
Lightening	11.3
Stratospheric decomposition of N <sub>2</sub> O	1.4
Ammonia oxidation	2.0
Aircraft	2.0

*Table 8*  
*Best estimates of contributions to global emissions of NO<sub>x</sub>*

The contributions from agriculture and from organic waste use are not well defined but best estimates suggest that agricultural soils account for 15% of global emissions (Lee, et al. 1997).

There is evidence for increasing nitric oxide emission from soils with increasing rates nitrogen fertiliser application. (Skiba, et al. 1997; Yeinger and Levy, 1995). There are very few data on the impact of organic wastes but application of these to land has potential for increasing emissions of nitric oxide (Watanabe, et al.. 1997; Veldcamp and Keller, 1997).

### 3. Methane

Methane strongly absorbs infra-red radiation and is one of the major greenhouse gases. It is also implicated in the reactions involving ozone.

#### Sources of methane

Methane is produced by the microbial process of methanogenesis which occurs in all anaerobic environments in which organic matter undergoes decomposition. On a global scale, natural wetlands and rice paddy fields are major sources of this gas accounting for about 40% of the total emission. Estimates of contributions to methane emission in Europe are summarised in Table 9 (Grosslinger, et al. 1996)

	% total CH <sub>4</sub>
Agriculture, forestry & land use change	46
Waste treatment and disposal	35
Extraction/distribution of fossil fuels	16
Miscellaneous	3

*Table 9*  
*Anthropogenic contributions to methane emission in EU 15 countries*

Agriculture is a significant source because methane is produced and released in large amounts from enteric fermentation in ruminant livestock. Estimates of methane emissions from farmed livestock in the UK (Table 10) illustrates that ruminant livestock, whether housed or grazing outdoors, are the main source of methane emission. (Sneath, et al. 1997)

Livestock	% total CH <sub>4</sub>
housing	43.9
manure storage	5.0
manure spreading	0.1
outdoor (incl. grazing)	51.0

*Table 10  
Contribution to methane emission from farmed livestock in the UK*

Organic wastes are generally anaerobic and may contain high concentrations of volatile fatty acids, precursors of methane formation, so their use leads to some emission but this is very small compared to that from enteric fermentation. Methane is released, probably from that entrapped in the slurry, for a brief period following the application of livestock slurries to land but ceases as oxygen diffuses into the manure. There is evidence that the manure and/or soil may sometimes act as a sink for methane.

### **Factors influencing methane release**

Unlike nitrous oxide, it appears unlikely that methane emission from waste application is mediated by soil processes although more anaerobic conditions may result in higher emissions. The composition of the waste is important and, for livestock manures, how this is influenced by the animals' diet. Storage conditions, especially temperature, is likely to have a large impact on emission from stores. Anaerobic digesters are designed to exploit the process by ensuring conditions favour biogas (methane+carbon dioxide) production for use as a fuel.

## **4. Odours**

Although not damaging to the environment, offensive odours from organic wastes are a major source of complaints from the public. The focus of research has been on livestock manures although complaints about odours from sewerage works and other industrial sources are common.

### **Sources of odour emission**

Livestock manures are significant sources of odour emission particularly when they are applied to the land surface with conventional machinery. The pattern of odour

emission is similar to that describe for ammonia although the frequency and number of complaints may be a reflection of social attitudes as well as the concentration of odour in air. Odour are complex mixtures of gases and volatile organic compounds with over 160 odorous compounds being identified in piggeries. ( O'Neil and Phillips, 1992). Because of this complexity, odour concentration in air is difficult to measure chemically and this has led to the development and use of olfactometric techniques. An olfactometer is used to present clean: odorous air dilutions to a panel of people to determine the 50% detection threshold, i.e. the number of dilutions at which 50% of the panel can just detect an odour, which is often expressed as Odour Units  $m^{-3}$  air. More recently, GC-MS has been used to study odour chemistry (Hobbs et al. 1995). This has shown that 15 compounds, which include VFAs, sulphides, phenols and indoles, are mainly responsible for odours from livestock manures. These are mainly derived from the digestion, and subsequent degradation in wastes, of nitrogenous compounds in the animals diet.

### **Factors influencing odour emission**

Many of the factors which influence ammonia emission (see Table 3) also affect odour emission (see Pain, 1994). The class of stock and their diet is also important, because these influence the concentrations of different odorous compounds in manure, together with the period of manure storage prior to spreading on land.

## **5. Other emissions**

Most of the information in this paper is about emissions from livestock manures which reflects the research activity in this area. The use of other organic wastes, particularly sewage sludges, may give rise to emissions of other trace organic contaminants and potentially toxic elements such as mercury (Hg). It is, however, a general view that the impact of sludge treated soils is probably small compared with background levels in the aerial environment. (Smith, 1996)

## **6. Strategies and techniques for abatement**

Modifying the design of buildings, installing air scrubbers or filters or covering stores offer a means of abating emissions from these sources. Incorporating a treatment stage in waste management offers a range of options as discussed by Burton in this volume. Options for the abatement of emissions from the use of organic wastes on land include :

- controlling the rate and time of application
- improved methods of application
- incorporation into the soil
- modifying the diet of livestock.

## Rate and time of application

Matching the rate and time of application of nitrogen in manures etc to a crop requirements ensures good recovery by plants with less opportunity for losses, for example, as nitrous oxide through denitrification.

## Method of application

Methods have been developed and used for decreasing the surface area of slurries exposed to the air so reducing ammonia emission. (Huijsmans 1997). These include bandspreaders, comprising trailing hoses or trailing shoes, and injectors making open or closed slots in the soil. Trailing hoses apply slurries in parallel bands to grassland or between the rows of cereals whilst trailing shoes are designed to place slurry on the soil surface rather on the grass sward and need a grass height of about 10cm to be effective. Open slot injectors normally operate to a depth of about 5cm whilst closed slot injectors commonly employ 15cm deep, winged tines. The efficiencies of these types of machine for reducing ammonia emission are compared with surface "broadcast" application in Table 11. These machines can also be used to reduce odour.

	% reduction compared with « broadcast »
Bandspreader	
Grassland	10
Arable	30
Trailing shoe	40
Injection	
Open slot	60
Closed slot	80
Incorporation	
Immediate	80
Same working day	40

*Table 11  
Ammonia abatement efficiencies of slurry application machinery compared with « broadcast » application.*

## Incorporation into soil

Incorporation of organic wastes into the soil is an effective means of reducing ammonia and odour emission. ( see paper by Huisjmans in this volume). Since rates of emission are very high for the few hours after spreading on the soil surface, incorporation must be done as soon as possible and preferably within 3-4 hours. The equipment used for incorporation will depend upon soil type but, in general,

ploughing to bury completely the manure is most effective. (Table 12). Odour emission is decreased also.

Method of incorporation	Immediate	3 hr delay	6hr delay
Plough	90	68	54
Rotavator	68	55	43
Tines	40	37	34

*Table 12*

*Effect of time and method of incorporating slurry into soil on ammonia emission*

### **Modifying the diet of livestock**

More accurately adjusting the protein contained in the diet of livestock to their requirements can lower the amount of surplus nitrogen excreted. This is more straightforward for pigs than for cattle because diets for the latter can be formulated accurately using synthetic amino acids.

Although more costly, such diets significantly decrease nitrogen excretion and subsequent emissions of gaseous nitrogen compounds and odours. (Hobbs et al. 1996; Misselbrook et al. 1998).

### **Interactions**

It is well established that controlling emissions may a) increase emission of the same compound at a "downstream" stage of management or, b) increase emission of another compound. For example, reducing ammonia emission from storage of slurries or composting of solid manure may increase emission of this gas from spreading on land unless an appropriate abatement technique is used. Similarly, deep injection of slurry may reduce ammonia emission but increase emission of nitrous oxide through enhanced rates of denitrification.

## **7. References**

**Amon B, Boxberger J, Amon Th, Zaussinger,A and Pollinger A (1998)** Emissions of ammonia, nitrous oxide and methane from a tying stall for milking cows during storage of solid manure and after spreading, See this volume.

**Beauchamp E G, Kidd G E and Thurtell G (1978)** Ammonia volatilization from sewage sludge applied in the field. *Journal of Environmental Quality* 7, 141-146

**Chadwick D R, Sneath Rw, Phillips V R and Pain B F (1998)** Methane and nitrous oxide emissions from the UK livestock sector. See this volume.

**ECETOC (1994)** Ammonia emissions to air in Western Europe. Technical Report No62. Brussels 196pp

**Genermont S and Cellier P (1997)** A mechanistic model for estimating ammonia volatilization from slurry applied to bare soil *Agricultural and Forest Meteorology* 88, 145-167

**Grosslinger E, Radunsky K and Ritter M (1996)** CORINAIR 1990 Summary Report. European Environment Agency, Copenhagen.

**Hobbs P J, Misselbrook T H and Pain B F (1995)** Assessment of agricultural odours by a photoionisation detector, an electronic nose, olfactometry and gas chromatography-mass spectrometry. *Journal of Agricultural Engineering Research* 60, 137-144.

**Hobbs P J, Pain B F, Kay R M and Lee P A.(1996)** Reduction of odorous compounds in fresh pig slurry by dietary control of crude protein. *Journal of the Science of Food and Agriculture* 71, 508-515.

**Huijsmans J F M, Hol J G M and Bussink D W (1997)** Reduction of ammonia emission by new slurry application techniques on grassland. In: *Gaseous Emissions of Nitrogen from Grassland*. S C Jarvis and B F Pain (eds) CABI Wallingford, pp281-285.

**Hutchings N J, Sommer S G and Jarvis S C (1996)** A model of ammonia volatilization from a grazing livestock farm *Atmospheric Environment* 30, 589-599

**Kroeze C (1995)** Comparison of inventory methods for estimating national emissions of nitrous oxide. *Quarterly Journal of the Hungarian Meteorological Service* 9, 209-225

**Lee D S, Bouwman A F, Asman W A H, Dentener F J, Van Der Hoek K W and Olivier J G J (1997)** Emission of nitric oxide, nitrous oxide and ammonia from grasslands on a global scale. In: *Gaseous Nitrogen Emissions from Grassland*. S C Jarvis & B F Pain (eds) CABI, Wallingford. 452pp

**Misselbrook T H, Chadwick D R, Pain B F and Headon D (1998)** Dietary manipulation as a means of reducing N losses, methane emissions and improving herbage N uptake following applications of pig slurry to grassland. *Journal of Agricultural Science, Camb.* 130, 183-191

**Mosier A R, Hutchinson G L, Sabey B R and Baxter J (1982)** Nitrous oxide emission from barley plots treated with ammonium nitrate or sewage sludge. *Journal of Environmental Quality* 22, 78-81.

**O'Neil D H and Phillips V R (1992)** A review of the control of odour nuisance from livestock buildings: Part 111 Properties of the odorous substances which have been identified in livestock wastes or in the air around them. *Journal of Agricultural Engineering Research* 53, 23-50.

**Pain B F (1994)** Odour nuisance from livestock production systems. In: *Pollution in Livestock Production Systems*. L Ap Dewi, R F E Axford, I F M Marai and H Omed (eds) CABI Wallingford, pp241-263.

**Pain B F, Phillips V R, Clarkson C R and Klarenbeek J V (1989)** Loss of nitrogen through ammonia volatilization during and following the application of pig or cattle slurry to grassland. *Journal of the Science of Food and Agriculture* 47, 1-12

**Sommer S G and Olesen (1991)** Effects of dry matter content and temperature on ammonia loss from surface applied cattle slurry. *Journal of Environmental Quality* 20, 679-683.

**Skiba U, Fowler D and Smith K A (1997)** Nitric oxide emissions from agricultural soils in temperate and tropical climates : sources, controls and mitigation options. *Nutrient Cycling in Agroecosystems* 48, 139-153.

**Smith K A and Chambers B J (1995)** Muck from waste to resource-utilisation: the impacts and implications. *Agricultural Engineering*, Autumn 1995, 33-38.

**Smith S R (1996)** *Agricultural Recycling of Sewage Sludge and the Environment*. CABI, Wallingford. pp382

**Sneath R W, Chadwick D R, Phillips V R and Pain B F (1997)** A UK inventory of methane emissions from farmed livestock, Final Report to MAFF, London. pp55.

**Veldkamp E and Keller M (1997)** Fertiliser induced nitric oxide emission from agricultural soils. *Nutrient Cycling in Agroecosystems* 48, 69-77

**Watanabe T, Osada T, Yoh M and Tsuruta H (1997)** N<sub>2</sub>O and NO emissions from grassland soils after application of cattle and swine excreta. *Nutrient Cycling in Agroecosystems* 49, 35-39.

**Yeinger J J and Levy H (1995)** Empirical model of global and soil-biogenic NO<sub>x</sub> emissions. *Journal of Geophysical Research* 100, 11447-11464.

# **Influence of slurry pretreatments and application techniques on ammonia emissions after landspreading of slurry on grassland.**

*Influence d'un prétraitement du lisier et des techniques d'épandage sur les émissions d'ammoniac après apport de lisier de porcs sur prairies.*

**P. Reitz and H. D. Kutzbach**

Institute of Agricultural Engineering, University of Hohenheim,  
D-70599 Stuttgart, Germany

## **Abstract**

*More than half of the German ammonia emissions are caused by the landspreading of slurry. Aftereffects as loss of nitrogen fertilizer and environmental damages should be reduced through suitable processing improvements in slurry management. For recording the influence of different slurry pretreatments and application techniques on the ammonia emissions after landspreading of cattle slurry on grassland a system of three parallel operated windtunnels was used.*

*Landspreading of separated slurry reduced the ammonia volatilization by 72 % for the liquid phase and by 32 % for the solid phase. The liquid phase with a dry matter content of 3.1 % infiltrated very fast into the soil in contrast to the solid phase. However, the solid phase covered only about 1/3 of the grassland surface because of the higher dry matter content of 16.1 %.*

*The assumption that following a pretreatment of slurry with certain additives the ammonia emissions after landspreading are reduced, was not verified. The additives "Zeolit", "Biplantol G" and "BVG-mixture" had no effect on the emissions as well as an addition of untreated lime or treated lime "Penac G".*

*The application of anaerobically fermented slurry even increased the ammonia emissions by 23 % for the mesophil phase and by 47 % for the thermophil phase. The decrease of the dry matter content and its reducing effect on the volatilization was covered from a very strong increase of the pH value, which caused higher emissions from the digested slurry.*

*Ammonia emissions could be reduced through application techniques which apply the slurry in narrow bands near or into the soil. In comparison to broadcast spreading with a splash plate, the nitrogen loss was reduced by 40 % using a trailing hose, by approximately 55 % using a trailing foot and even by 75 % using the trenching technique. The disadvantages of an application technique which incorpo-*



*rates the slurry into the soil are a higher draftforce requirement and an increase of the CO<sub>2</sub> and N<sub>2</sub>O emissions. Therefore the most suitable application techniques are the one which apply the slurry near the soil.*

*Therefore the application techniques have a very high potential to reduce the ammonia emissions after landspreading of slurry, in contrast to the different pretreatments of the slurry, which can have a reducing effect or none effect or even a rising effect on the ammonia emissions.*

*Further researches on the influence of climatic conditions such as air temperature, soil humidity, windspeed and radiation are just under investigation.*

**Keywords :** windtunnel, ammonia emission, slurry pretreatments, application techniques.

## **Résumé**

Suite au fait que l'épandage de lisier cause plus de la moitié des émissions d'ammoniac de l'Allemagne et que souvent plus de 50% de l'azote du lisier sont perdus pendant l'épandage, une étude des facteurs qui influencent ces pertes, a été réalisée. Comme stations d'essai, trois tunnels ont été construits, qui permettent de mesurer au champ les émissions d'ammoniac en variant un seul facteur d'influence. La calibration des tunnels avec gaz d'ammoniac aboutit à un taux de recouvrement de 77 à 99% de l'ammoniac. Des investigations sur l'influence de différentes techniques d'épandage de lisier sur les émissions d'ammoniac, ont montré que comparativement à un épandage de surface, l'épandage à l'aide de « tuyaux traînés » diminue de 40% les émissions. Avec un « trailing foot » la diminution est de 55% et avec un soc d'enfouissage en ligne de 75%. Donc, les émissions peuvent être réduites si le lisier est épandu directement sur ou dans le sol. Une séparation du lisier avant l'épandage donne une réduction de 32% si seulement la phase solide est épandue et 72% pour la phase liquide. La phase solide couvre avec 16,1% de MS seulement un tiers de la surface et la phase liquide avec 3,1% MS est rapidement absorbé par le sol. L'utilisation des additifs « Zeolith » et « Biplantol G » n'a aucune influence sur les émissions d'ammoniac, de même que la poudre de chaux non pré-traitée et pré-traitée « Penac G ». Des investigations sur l'influence d'une fermentation aérobie et anaérobie avant l'épandage et sur l'influence des conditions climatiques pendant l'épandage sont à l'étude.

**Mots-clés :** tunnel, émissions d'ammoniac, techniques d'épandage de lisier, pré-traitement de lisier.

## 1. Materials and methods

For recording the factors of influence on the ammonia emissions after landspreading of slurry, the Institute of Agricultural Engineering of the University of Hohenheim developed a windtunnel system (Falk, 1994). A parallel operation of three windtunnels allows a specific variation of one influence factor under constant ambient conditions (fig.1).

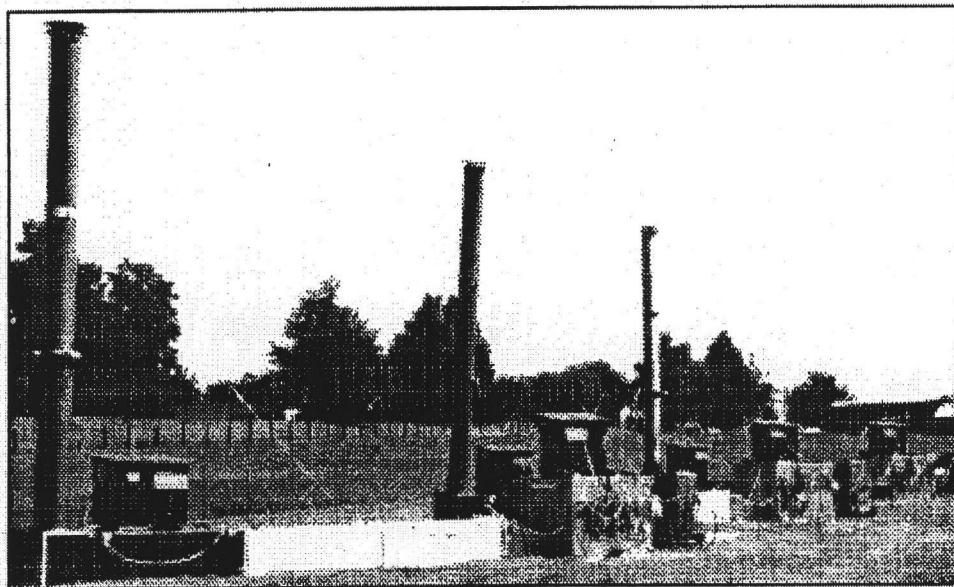

*Figure 1*  
*Windtunnel system of Hohenheim*

Researches on the accuracy of the windtunnel system gave percentages recovery ranging 77 % to 99 %. A representative sampling could be confirmed by the equality of the different samplers. An equalization of the three windtunnels gave a maximal  $\text{NH}_4\text{-N}$  difference of 200  $\text{mg}/\text{m}^2$  in 48 h (Reitz and Kutzbach, 1997). The accuracy of the Hohenheim windtunnel is similar to the one of other systems (Van der Weerden et al., 1996; Katz, 1996), thus, a reproducible quantification of ammonia emissions is ensured.

## 2. Results and discussion

So far researches on the influence of different slurry pretreatments and application techniques were carried out. As an example for the pretreatments the influence of a separation on the ammonia emissions is presented. Figure 2 and Figure 3 depict a comparison of an untreated slurry with the solid and liquid phase of a separated slurry. The ammonia emissions are shown in Figure 2 as the cumulative loss of  $\text{NH}_3\text{-N}$  expressed as the percentage loss of applied total ammoniacal nitrogen (TAN) from the slurry. Figure 3 presents the ammonia emission rates expressed in  $\text{mg/m}^2 \text{ h}$ .

For the separation a cattle slurry with a dry matter content of 8.9 % and a  $\text{NH}_4\text{-N}$  concentration of 0.161 % was used. After the separation the dry matter content and the  $\text{NH}_4\text{-N}$  concentration of the liquid phase amounted to 3.1 % or 0.145 % respectively. The dry matter content of the solid phase was 16.1 %, the  $\text{NH}_4\text{-N}$  concentration amounted to 0.187 %. The amount of broadcast spread slurry was  $2.9 \text{ kg/m}^2$ , thus, the amount of ammonium nitrogen applied was  $4669 \text{ mg/m}^2$  for the untreated slurry,  $4205 \text{ mg/m}^2$  for the liquid phase and  $5423 \text{ mg/m}^2$  for the solid phase. The climatic conditions during this research in June 1997 are also shown in Figure 2.

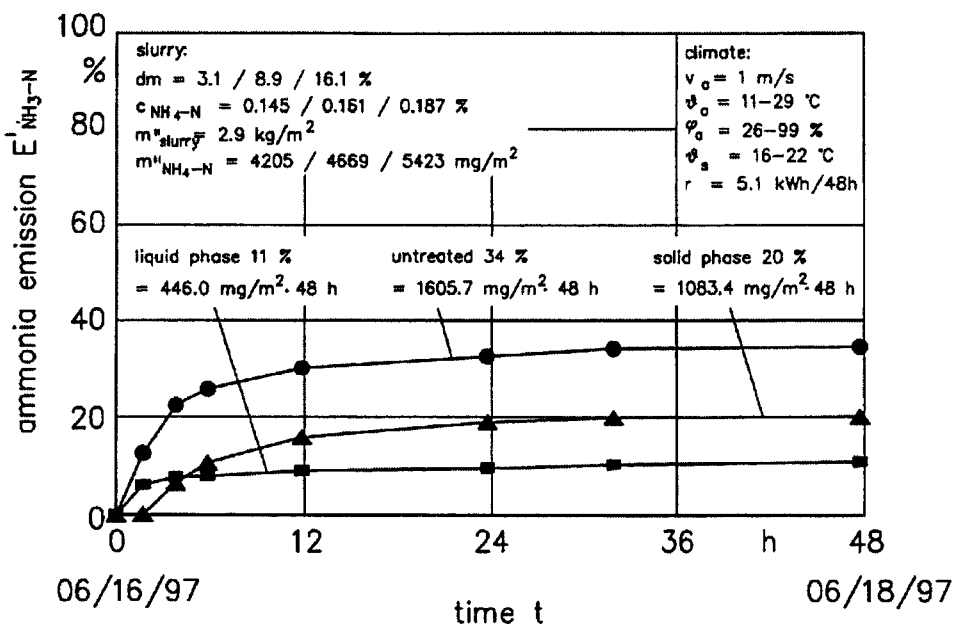

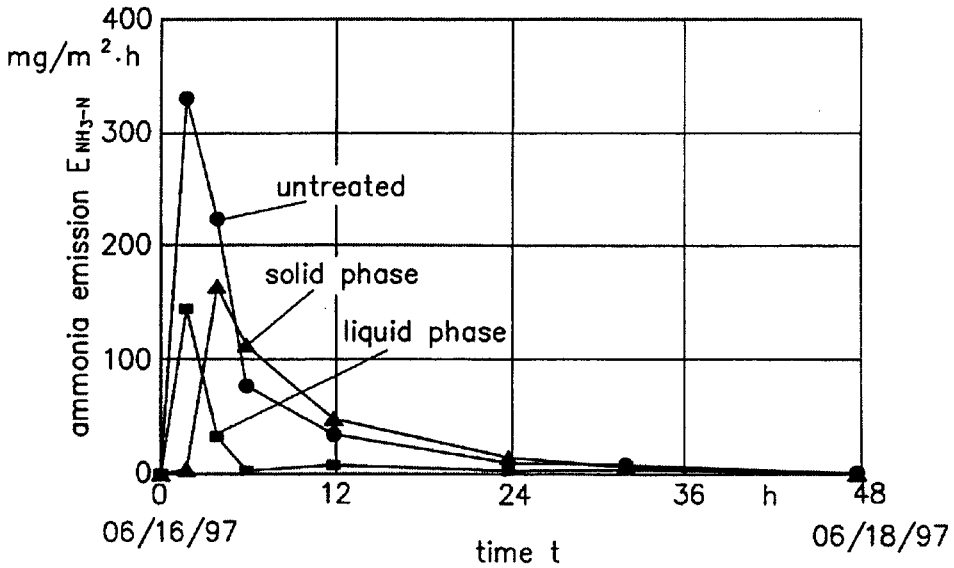

Figures 2 and 3

*Influence of separation on ammonia emissions, comparison of a untreated slurry with the solid and liquid phase of a separated slurry*

The highest nitrogen loss was found for the untreated slurry. Its total ammonia loss amounted to 1605.7 mg/m<sup>2</sup> in 48 h, that corresponds to a cumulative loss of 34 % of the TAN applied. By the solid phase emitted 1083.4 mg/m<sup>2</sup> in 48 h or 20 %. With a total loss of 446.0 mg/m<sup>2</sup> in 48 h or 11 % the liquid phase showed the lowest emission. The emissions of the untreated slurry were approximately two-fold higher than the ones of the solid phase and even threefold higher than the emissions of the liquid phase. If the emission of the untreated slurry is rated as 100 %, the loss of the solid phase is 68 % and the loss of the liquid phase 28 % of the amount of the untreated slurry. This corresponds to a reduction of the nitrogen loss of 32 % for the solid phase and of 72 % for the liquid phase.

The reduction potential of the separated slurry is explained through the changes in the dry matter content. Due to the lower dry matter content the liquid phase had a lower viscosity and infiltrated better and faster into the soil. Thus, an emitting surface existed only a short time, which is emphasized by the low emission peak of 144 mg/m<sup>2</sup> h<sup>-1</sup> already 2 h after landspreading. As opposed to this the solid phase had with 163 mg/m<sup>2</sup> h<sup>-1</sup> the highest emission rate 4 h after the application, because only one third of the grassland surface was covered with slurry. The solid phase stucked on the grassland plants because of the higher dry matter content, which explains the following higher emission rate. Caused by the great emitting surface the untreated slurry had with 331 mg/m<sup>2</sup> h<sup>-1</sup> as well 2 h after landspreading an

emission peak. Afterwards the emission rate of the untreated slurry declined faster than the one of the solid phase, since the slurry was better absorbed from the soil because of its lower dry matter content. For all three slurries approximately 90 % of the total emission occurred already after 24 h. At the second day the emission rates were very low and the concentrations were only slightly over the background atmospheric ammonia concentration.

Pain et al. (1990) found corresponding reductions of the nitrogen loss by the liquid and solid phase of a separated pig slurry. Thompson et al. (1990) determined similar ammonia emissions from an unseparated slurry and a liquid phase of a separated slurry, because of a very small difference in the dry matter contents of only 1.5 %. In contrast to this Dosch (1996) found, a decrease of the nitrogen loss by the liquid phase, but an increase by the solid phase. In the sum of liquid and solid phase the ammonia emissions of the separated slurry were still less than the one of the unseparated slurry. Thus, the separation technique is an efficient possibility to reduce the nitrogen loss, provided that the change of the dry matter content is high enough.

A survey of the influence of further pretreatments and application techniques on the ammonia emissions after landspreading of slurry is given in Table 1. There are presented as the cumulative percentage ammonia emissions of different slurry additives, anaerob fermented slurry and slurry applied with different application techniques.

The addition of untreated lime or treated lime "Penac G" had no influence on the reduction of the ammonia emissions. Due to a very low dry matter content of 2.9 % and a very dry soil (soil moisture 14 %) all emissions were very low. Since the differences between the variations were smaller than the measurement deviations of the windtunnel system, no differences between those additives could be obtained. In the same way the ammonia emissions could not be reduced through the additives "Zeolit", "Biplantol" and "BVG-mixture". In oppose to this, Mannheim (1994) found under different conditions a reduction of the ammonia emission by 16 % using "Penac G". Martinez et al. (1997) examined five additives and could only determine a reducing effect for two. Moreover additives mainly influence the homogenization of the slurry and have only a limited effect on the reduction of ammonia emissions (Kunz, 1997).

influence factor	variation and cumulative percentage ammonia emission					
	untreated	12 %	lime	17 %	Penac G	14 %
additive	untreated	29 %	Zeolit	29 %	Biplantol G	27 %
additive	untreated	30 %	Zeolit	31 %	BVG-mixture	29 %
anaerob fermentation	untreated	29 %	mesophil	36 %	thermophil	41 %
application technique	splash plate	27 %	trailing foot	13 %	trenching	6 %
application technique	splash plate	24 %	trailing hose	15 %	trailing foot	9 %

*Table 1*  
*Cumulative percentage ammonia emissions by different pretreatments and application techniques*

Through an anaerobic digestion of the slurry during the production of biogas the ammonia emissions even increased by 23 % for the mesophil phase and by 47 % for the thermophil phase. The low decrease of the dry matter content from 6.0 % over 5.9 % to 5.5 % and its reducing effect on the volatilization was covered from a very strong increase of the pH value from 7.5 over 7.9 to 8.1. Mannheim (1994) found similar increases, whereas by Pain et al. (1990) the nitrogen loss of the anaerob fermented slurry was slightly reduced. Therefore an anaerobic fermentation is only efficient, if the emission reducing decrease of the dry matter content is higher than the emission increasing growth of the pH value.

By means of application techniques which apply the slurry in narrow bands near or into the soil and therefore diminish the contact surface between slurry and atmosphere, the nitrogen losses can be reduced very efficiently. In comparison to broadcast spreading with a splash plate, the ammonia emissions could be reduced by 39 % using the trailing hose, between 52 % and 61 % using the trailing foot and even by 74 % using the trenching technique. Similar reduction potentials were found by Lorenz and Steffens (1996), Bussink (1997), Depta et al. (1997) and Frick and Menzi (1996). An application technique which incorporates the slurry into the soil has some disadvantages as a higher draftforce requirement and increasing CO<sub>2</sub> and N<sub>2</sub>O emissions (Schürer and Reitz, 1998). Thus, application techniques which apply the slurry near the soil are the most suitable ones.

Since ammonia emissions are mainly influenced by the climatic conditions during the landspreading of slurry, further researches on the influence of air temperature, soil humidity, windspeed and radiation are just under investigation.

### 3. References

**Bussink, W.:** Ausbringtechniken auf Grün-und Ackerland in den Niederlanden. KTBL Arbeitspapier 242, Darmstadt, Germany, S. 218/226, 1997.

**Depta, G., S. Nesor, S.C. Becher, A. Gronauer, I. Steinicke, A. Sedlmaier and K. Schäfer:** Distinction between Different Slurry Application by their Ammonia Emission with FTIR-Open-Path Measurements and Dispersion Modelling. Proceedings of the International Symposium on Ammonia and Odour Control from Animal Production Facilities, Vinkeloord, Netherlands, vol. 1, pp. 175/183, 1997.

**Dosch, P.** Optimierung der Verwertung von Güllestickstoff durch Separiertechnik und kulturspezifische Applikationstechniken. Dissertation TU München, Lehrstuhl für Pflanzenernährung, Gelbe Heftreihe Nr.56, 1996.

**Frick, R. und H. Menzi:** Hofdüngeranwendung: Wie Ammoniakverluste vermeiden? FAT Bericht Nr. 496, Eidgenössische Forschungsanstalt für Agrarwirtschaft und Landtechnik, Tänikon, Switzerland, 1996.

**Katz, P.:** Ammoniakemissionen nach der Gülleanwendung auf Grünland. Dissertation ETH Zürich Nr. 11382, 1996.

**Kunz, H.-G.:** Personal Informations. LVVG Aulendorf, Germany, 1997.

**Lorenz, F. und G. Steffens:** Gülleeinsatz auf Grünland mit unterschiedlichen Verteiltechniken. KTBL, Darmstadt, Germany, 1996.

**Mannheim, T.:** Ammoniakemissionen von landwirtschaftlichen Nutzflächen: Quellen und Minderungsmaßnahmen. Dissertation Universität Hohenheim, Institut für Pflanzenernährung, 1994.

**Martinez, J., J. Jolivet, F. Guiziou and G. Langeoire:** Ammonia Emissions from Pig Slurry; Evaluation of Acidification and the Use of Additives for Reducing Losses. Proceedings of the International Symposium on Ammonia and Odour Control from Animal Production Facilities, Vinkeloord, Netherlands, vol. 1, pp. 485/492, 1997.

**Pain, B.F., T.H. Misselbrook, C.R. Clarkson and Y.J. Rees:** Odour and Ammonia Emissions Following the Spreading of Anaerobically-Digested Pig Slurry on Grassland. Biological Wastes 34, pp. 259/267, 1990.

**Pain, B.F., V.R. Phillips, J.F.M. Huijsmans and J.V. Klarenbeek:** Anglo-Dutch experiments on odour and ammonia emissions following the spreading of piggery wastes on arable land. Research Report 91-9, IMAG-DLO Wageningen, Netherlands, 1991.

**Reitz, P. and H.D. Kutzbach:** Accuracy of a Windtunnel System for Measuring Ammonia Emissions after Slurry Application. Proceedings of the International Symposium on Ammonia and Odour Control from Animal Production Facilities, Vinkeloord, Netherlands, vol. 2, p. 595/598, 1997.

**Schürer, E. and P. Reitz:** Emissionen von Ammoniak und Lachgas - Einfluß des Ausbringverfahrens von Flüssigmist. Landtechnik 53, Nr. 1, S. 36/37, 1998.

**Thompson, R.B, B.F. Pain and D.R. Lockyer:** Ammonia volatilization from cattle slurry following surface application to grassland - influence of mechanical separation, changes in chemical composting during volatilization and the presence of the grass sward. Plant and Soil 125, p. 109/117, 1990.

**Van der Weerden, T.J., J.F. Moal, J. Martinez, B.F. Pain and F. Guiziou:** Evaluation of the Wind-Tunnel Method for Measurement of Ammonia Volatilization from Land. Journal of Agricultural Engineering and Research 64, p. 11/14, 1996.





## Gaseous emissions from dairy cattle collecting yards.

*Emissions gazeuses issues des zones de stabulation des vaches laitières.*

**Misselbrook, T. H.; Pain, B. F.; Chadwick, D. R. and Headon, D. H.**

Institute of Grassland and Environmental Research, North Wyke,

Okehampton, Devon, EX20 2SB, UK.

E-mail : tom.misselbrook@bbsrc.ac.uk

### Abstract

*Dairy cattle collecting yards may represent significant sources of emission of ammonia (NH<sub>3</sub>), methane (CH<sub>4</sub>) and nitrous oxide (N<sub>2</sub>O). A system of small wind tunnels was used to measure NH<sub>3</sub> emission from a known quantity of urine and faeces applied to concrete and to assess the impact on emission of cleaning the concrete by hosing or scraping. NH<sub>3</sub> emission measurements were also made from the collecting yard of a commercial dairy farm using either a Lindvall hood or a system of dynamic chambers. Measurements of CH<sub>4</sub> and N<sub>2</sub>O emission were made from the collecting yard using closed cover boxes. From the wind tunnel measurements, mean NH<sub>3</sub> emission from urine and faeces applied to concrete was estimated to be 50 % of the applied urea-N. Cleaning the concrete by hosing was more effective than scraping in reducing NH<sub>3</sub> emission. From Lindvall hood measurements, emission from the collecting yard was greater in summer than winter, with a mean emission over both periods of 4.5 g NH<sub>3</sub>-N.m<sup>-2</sup>.d<sup>-1</sup> equating to 6.4 g NH<sub>3</sub>-N.cow<sup>-1</sup>.d<sup>-1</sup>. Mean emission measured using the dynamic chambers (measured over a winter period) was estimated to be 6.5 g NH<sub>3</sub>-N.cow<sup>-1</sup>.d<sup>-1</sup>. Emissions of CH<sub>4</sub> and N<sub>2</sub>O were much lower, measured as 2 mg.m<sup>-2</sup>.d<sup>-1</sup> and 0.2 mg N.m<sup>-2</sup>.d<sup>-1</sup> respectively. Rates of emission were subject to large spatial and temporal variation.*

### Résumé

Les zones de stabulation des animaux peuvent représenter des sources significatives d'ammoniac (NH<sub>3</sub>), de méthane (CH<sub>4</sub>) et de protoxyde d'azote (N<sub>2</sub>O). Un système de tunnels ventilés a été utilisé pour mesurer les émissions d'NH<sub>3</sub> à partir d'une quantité connue d'urine et de fèces épandues sur revêtement béton afin de vérifier l'impact sur ces émissions du nettoyage de la surface à l'eau ou du raclage.

Les émissions d'ammoniac ont été également mesurées sur une exploitation agricole à l'aide d'un système de boîte de Lindvall ou de chambre dynamique. Les mesures de CH<sub>4</sub> et N<sub>2</sub>O ont été effectuées à l'aide de boîtes couvertes. A partir des

- mesures à l'aide des tunnels de ventilation, les émissions moyennes d' $\text{NH}_3$  issues des urines et fèces apportées sur béton ont été estimées à 50% de l'azote urée apportée. Le nettoyage des dalles béton à l'eau s'est avéré plus efficace que le raclage dans la réduction des émissions d'ammoniac. A partir des mesures à l'aide des chambres de Lindvall, il apparaît que les émissions d'ammoniac étaient supérieures en été comparativement à la période hivernale, avec un taux moyen établi sur ces 2 périodes de  $4,5 \text{ g N-NH}_3 \text{ m}^{-2} \cdot \text{j}^{-1}$  ce qui représente  $6,4 \text{ g N-NH}_3 \cdot \text{vache}^{-1} \cdot \text{j}^{-1}$ . Les mesures à l'aide des chambres dynamiques conduisent à un taux moyen d'émission de  $6,5 \text{ g N-NH}_3 \cdot \text{vache}^{-1} \cdot \text{j}^{-1}$ .

Les émissions de  $\text{CH}_4$  et  $\text{N}_2\text{O}$  étaient bien inférieures, de l'ordre de  $2 \text{ mg} \cdot \text{m}^{-2} \cdot \text{j}^{-1}$  et  $0,2 \text{ mg N} \cdot \text{m}^{-2} \cdot \text{j}^{-1}$  respectivement. Les taux d'émission étaient soumis à de larges variations spatiales et dans le temps.

## Introduction

Many livestock, and dairy cattle in particular, spend time on uncovered yard areas, which will become contaminated with urine and faeces. These areas may represent sources of gaseous emission which, to date, have received little attention. Of particular concern are emissions of ammonia ( $\text{NH}_3$ ), methane ( $\text{CH}_4$ ) and nitrous oxide ( $\text{N}_2\text{O}$ ).

$\text{NH}_3$  emissions from cattle excreta derive mainly from urine. Urea is the major N containing constituent of urine and, after excretion and contact with the ubiquitous enzyme urease, is hydrolysed to  $\text{NH}_3$ . Studies have shown that emission from urine returns by grazing cattle can account for between 4 and 35 % of the total urine N content (Ball *et al.*, 1979; Vertregt and Rutgers, 1987; Lockyer and Whitehead, 1990) and exceptionally 66 % under hot, dry conditions (Ball and Ryden, 1984). Emissions from faeces alone are much lower, generally less than 5 % total N content (MacDiarmed and Watkin, 1972; Ryden *et al.*, 1987). We might expect emissions from urine deposits on non-porous concrete yards to be greater than those from grassland, due to lack of infiltration and an increase in surface area from which volatilisation can occur as the urine spreads across the yard surface.

Approximately 90 % of  $\text{CH}_4$  emission from UK agriculture derive from enteric fermentation in cattle (Chadwick *et al.*, 1998). However, freshly voided dung from grazing animals has the potential for  $\text{CH}_4$  emission as it carries the appropriate organisms (Dar and Tandon, 1987). Jarvis *et al.* (1995), measuring emissions from cattle grazing returns, reported a mean cumulative emission from dung pats of  $981 \text{ mg CH}_4 \cdot \text{m}^{-2}$ , with a range in emission for dairy cows of  $716 - 2040 \text{ mg CH}_4 \cdot \text{m}^{-2}$ . There was no emission from urine patches. Interactions with the soil were thought to be minor, with the emission deriving directly from the dung. Therefore we might expect emissions from dung pats on concrete yards to be of a similar order to those from grazing returns.

N<sub>2</sub>O emissions arise from denitrification and nitrification which are primarily soil-based microbial processes. Measurements from grazing returns show emissions to be greater from urine than dung patches (Oenema *et al.*, 1997). Emissions from concrete yards may be lower than from grazing returns due to the microbial processes being primarily soil based.

The aim of the work presented in this paper was to quantify emissions of NH<sub>3</sub>, CH<sub>4</sub> and N<sub>2</sub>O from dairy cattle collecting yards and to examine some of the factors influencing emissions. A pilot study, measuring only NH<sub>3</sub> emissions was carried out during 1996. A more detailed study, measuring NH<sub>3</sub>, CH<sub>4</sub> and N<sub>2</sub>O commenced in November 1997. This study is part of a larger project being conducted jointly by IGER and ADAS in which emissions from different types of yard areas will be measured on a number of farms. Initial results from the dairy collecting yard of a farm being studied by IGER are presented here.

## Materials and Methods

### *Ammonia*

Two approaches were taken in the pilot study; a system of small wind tunnels (Lockyer, 1984) was used to measure NH<sub>3</sub> emission from known quantities of urine and faeces applied to concrete areas and to assess the effectiveness of cleaning the concrete by hosing or scraping, and a Lindvall hood (Lindvall *et al.*, 1974) was used to measure emissions from the collecting yard of a commercial dairy farm.

Using the system of small wind tunnels, NH<sub>3</sub> emission measurements were made from 1 l urine applied to 1 m<sup>2</sup> concrete. Air flow through the tunnels was controlled at 1 m.s<sup>-1</sup>. Acid traps (bubblers) containing 0.02 M orthophosphoric acid were used to measure the NH<sub>3</sub> concentration of the air entering and leaving each tunnel. Emission was calculated as the product of the difference in NH<sub>3</sub> concentrations of outlet and inlet air and the volume of air flowing through each tunnel. Six experiments were conducted; experiments 1 - 4 on concrete areas which had previously been used by beef cattle and experiments 5 and 6 on clean, previously unused concrete areas. Experiment 1 examined the effect of the presence or absence of faeces on emission. In all the other experiments faeces was applied to the concrete prior to urine application. Experiment 2 assessed the effectiveness of hosing with water in cleaning the concrete and experiments 3 - 6 assessed the effectiveness of cleaning the yard using a hand scraper. Experiments 1 - 4 were conducted in September and 5 and 6 in November. Samples of urine were collected for urea-N analysis at the time of application.

Measurements of NH<sub>3</sub> emission were made from the dairy cow collecting yard of Oaklands Farm using a Lindvall hood. Management practices on the farm were

common to those used by many UK dairy farmers, with 65 - 80 cows being milked twice each day, gathered in a concrete-surfaced collecting yard prior to milking, the yard being cleaned daily (after morning milking) using a hand-held scraper. The hood covered an area of 0.9 m<sup>2</sup> over which air was blown at a constant rate of approximately 1m.s<sup>-1</sup>. NH<sub>3</sub> was scrubbed from the inlet air using a glass wool filter coated with oxalic acid. NH<sub>3</sub> concentration of inlet and outlet air was measured using bubblers and emission calculated as for the wind tunnels. The hood was left on the yard for a 24 h period, being temporarily removed while cows were in the yard for milking and when the yard was being scraped. Measurements were made from 5 different yard positions over a period of three weeks during both summer and winter.

Following the pilot study, a more detailed study commenced in November 1997 measuring emissions from the same collecting yard at Oaklands Farm as in the pilot study. NH<sub>3</sub> emission was measured using a system of dynamic chambers. Full details of the method are given in Svensson (1994). Briefly, the method relies on theory derived from the meteorological law of resistance :

$$\phi_{\text{NH}_3} = (C_{\text{eq}} - C_{\text{a,z}})K_{\text{z,a}}$$

where  $\phi_{\text{NH}_3}$  is the NH<sub>3</sub> emission per unit area and time,  $C_{\text{eq}}$  is the NH<sub>3</sub> equilibrium concentration in the air at the soil surface,  $C_{\text{a,z}}$  is the ambient NH<sub>3</sub> concentration at height  $z$  and  $K_{\text{z,a}}$  is the mass transfer coefficient in the air above the soil. Using a system of dynamic chambers together with ambient samplers, the parameters  $C_{\text{eq}}$ ,  $C_{\text{a,z}}$  and  $K_{\text{z,a}}$  can be determined. Six chambers and four ambient samplers were used, allocated randomly across the yard. Emission rates were measured throughout the day, typically at 8 am (just after yard scraping), 11.30 am, 3 pm, 7 pm (after evening milking) and 10 pm. On one occasion further measurements were made throughout the night to give the full pattern of emission over 24 h. Emission rates for periods between measurements were estimated as the mean of that for the period before and after. Measurements were made at approximately three week intervals.

### **Methane and Nitrous Oxide**

CH<sub>4</sub> and N<sub>2</sub>O emission measurements also commenced in November 1997 and were made on the same collecting yard using closed chambers. Each chamber was fitted with a silicon rubber septum to allow samples of air to be taken by syringe. The chamber was weighted with a brick and a neoprene rubber seal was glued to the lower flange to provide a good seal with the yard surface. Samples of air were taken from the chambers 0, 20 and 40 minutes after placing them on the yard surface to determine the increase in CH<sub>4</sub> and N<sub>2</sub>O with time. Gas samples were stored in evacuated vials before analysis by gas chromatography. As for NH<sub>3</sub> measurements, the chambers were positioned randomly across the yard. Notes were made of the nature of the yard beneath each chamber, *i.e.* the presence or absence of a dung pat, a dirtied area or a clean area.

## Results and Discussion

### Ammonia

Results of the six wind tunnel experiments are given in Table 1. When urine was applied to clean concrete, rather than concrete dirtied with faeces, emission was minimal. This is more likely to have been due to rapid evaporation, which occurred within 2 h, than to an absence of urease. Areas where faeces had also been applied remained wet for much longer, allowing volatilisation to continue for longer.

Expt.	Duration h	Mean temp. °C	Urea-N input g/m <sup>2</sup>	Emission of NH <sub>3</sub> -N (g/m <sup>2</sup> )		
				not cleaned	cleaned 2h	cleaned 6h
1	76	14.9	7.7 (0.38)	0.1 (0.03) <sup>†</sup>	-	-
			-	4.3 (0.82) <sup>†</sup>	-	-
2	29	12.3	6.6 (0.56)	2.0 (0.77)	0.3 (0.15)	1.1 (0.05)
3	29	13.5	4.6 (0.69)	1.5 (0.80)	0.5 (0.11)	0.9 (0.17)
4	22	13.9	6.6 (0.28)	1.6 (0.58)	1.0 (0.04)	1.5 (0.42)
5	75	11.3	5.5 (0.49)	2.2 (0.06)	1.3 (0.07)	1.2 (0.31)
6	78	8.3	6.4 (0.29)	2.4 (0.07)	1.3 (0.23)	2.0 (0.62)

( ) standard error    † urine only applied    ‡ urine and faeces applied

Table 1.

NH<sub>3</sub> emission from 1 l urine applied to 1 m<sup>2</sup> concrete - wind tunnel measurements.

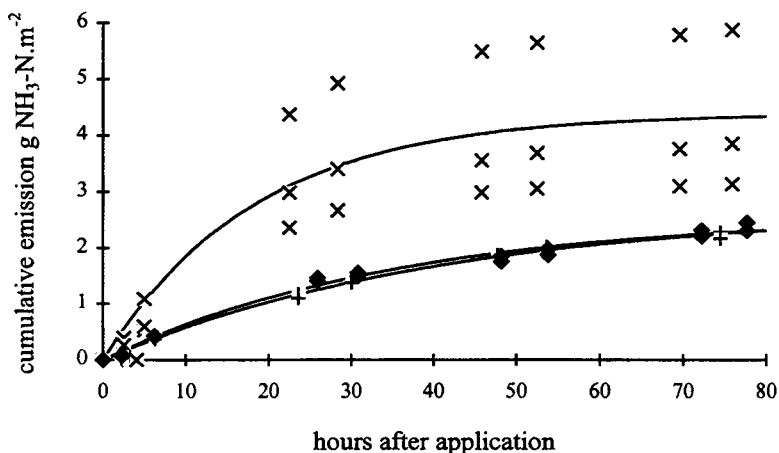

Figure 1

Cumulative NH<sub>3</sub> emission from 1 l urine applied to 1 m<sup>2</sup> concrete.  
Data from experiments 1 (x), 5 (+) and 6 (◆) together with fitted lines.

Experiments 1, 5 and 6 were of sufficient duration for a model of cumulative NH<sub>3</sub> emission versus time to be fitted (Fig 1) in the form  $E_t = N_{\infty} (1 - e^{-\beta t})$ , where  $E_t$  is the cumulative emission at time  $t$ ,  $N_{\infty}$  is the theoretical cumulative emission after infinite time and  $\beta$  is a constant. Estimated final cumulative emissions were 57, 49 and 41 % of the applied urea-N for experiments 1, 5 and 6 respectively, giving a mean cumulative emission of 49 % applied urea-N. Differences in final cumulative emission may have been due to differences in ambient temperature. The differences in pattern of emission with time, with proportionately more of the emission in experiment 1 occurring soon after application, may have been due to differences in urease activity on the concrete areas used, that used for experiments 5 and 6 being new, clean concrete on which urease activity may have been much lower.

Cleaning the concrete by hosing was more effective than scraping, with respective reductions in emission from cleaning after 2 h of 85 and 50 % and from cleaning after 6 h of 45 and 25 % compared to emission from an uncleaned control. In practice, a tractor-mounted scraper may be less effective at removing the faeces and urine than the hand-held scraper used in these experiments. Scraping passages in cubicle housing has been reported to have little effect on emission (Kroodsma *et al.*, 1993; Braam *et al.*, 1997) although flushing with water reduced emission by 70 % (Kroodsma *et al.*, 1993).

NH<sub>3</sub> emissions from the dairy cow collecting yard at Oaklands Farm measured using the Lindvall hood are given in Table 2. Taking into account the area of the yard (87 m<sup>2</sup>) and the number of cows being milked on each occasion, the mean emission over both summer and winter measurement periods was 6.4 g N.cow<sup>-1</sup>.d<sup>-1</sup>.

Measurement	Summer		Winter	
	Mean air temp °C	Emission g N.m <sup>-2</sup> .d <sup>-1</sup>	Mean air temp. °C	Emission g N.m <sup>-2</sup> .d <sup>-1</sup>
1	16.3	1.80	1.5	0.23
2	15.4	2.79	4.4	0.90
3	15.6	13.96	8.9	1.12
4	16.1	6.95	0.0	2.01
5	19.1	18.65	-	-
	Mean Summer	8.83	Mean Winter	1.07

Table 2.  
NH<sub>3</sub> emission from Oaklands Farm collecting yard;  
summer and winter measurements using Lindvall hood.

Emissions were much lower in the winter than in the summer. This was probably due to a combination of lower temperatures and a lower urea-N content of the urine (3.1 g.l<sup>-1</sup> in winter compared to 11.1 g.l<sup>-1</sup> in summer) resulting from dietary differences between the two periods.

Disadvantages of the hood method of  $\text{NH}_3$  emission measurement are that emission is not measured under ambient conditions (with wind speed controlled at  $1 \text{ m.s}^{-1}$  and rainfall excluded) and measurements can only be made from one small area of yard at any one time, thereby taking no account of spatial variability. It was for these reasons that the system of dynamic chambers were used to measure  $\text{NH}_3$  emission in the more detailed study, as measurements can be made from several positions simultaneously and under ambient conditions.

Date	Duration h	Mean air temp. $^{\circ}\text{C}$	Cumulative emission	
			$\text{g N.m}^{-2}$	$\text{g N.cow}^{-1}.\text{d}^{-1}$
6 November	20	10.8	2.77	3.61
26 November	14	10.8	5.88	10.96
22 December	15	7.1	7.47	13.00
14 January	15	5.3	1.12	1.95
12 February	25	9.8	3.28	3.42
5 March	14	7.7	3.38	6.30
			<b>Mean</b>	<b>6.54</b>

*Table 3.*  
 *$\text{NH}_3$  emission from Oaklands Farm collecting yard measured using dynamic chambers.*

Results of the dynamic chamber measurements, for the first six sampling dates (covering the winter period), are given in Table 3. The emission rates varied throughout the day, but typically decreased from an initially high value immediately after scraping in the morning to very low rates throughout the day (even becoming negative, indicating deposition from surrounding ammonia sources such as slurry lagoons and animal buildings), then increasing again after evening milking (Fig 2). Scraping the yard after morning milking obviously removes the majority of the faeces and urine from the yard surface. However, a thin layer remains from which emission occurs, but which soon becomes depleted. During evening milking, fresh deposits of urine and faeces are made to the yard and are not scraped away, so emission increases to a maximum rate after a few hours and then decreases again until morning milking. Actual emission rate will depend on the amount of ammoniacal-N present on the yard surface and the resistance to volatilisation. Conditions which promote fast drying of the yard will result in high emission rates which rapidly decline. Re-wetting of the yard (e.g. due to rainfall) may promote further emission. Heavy rain may wash urine and faeces off the yard and may also increase the efficiency of yard scraping, thereby decreasing emissions.



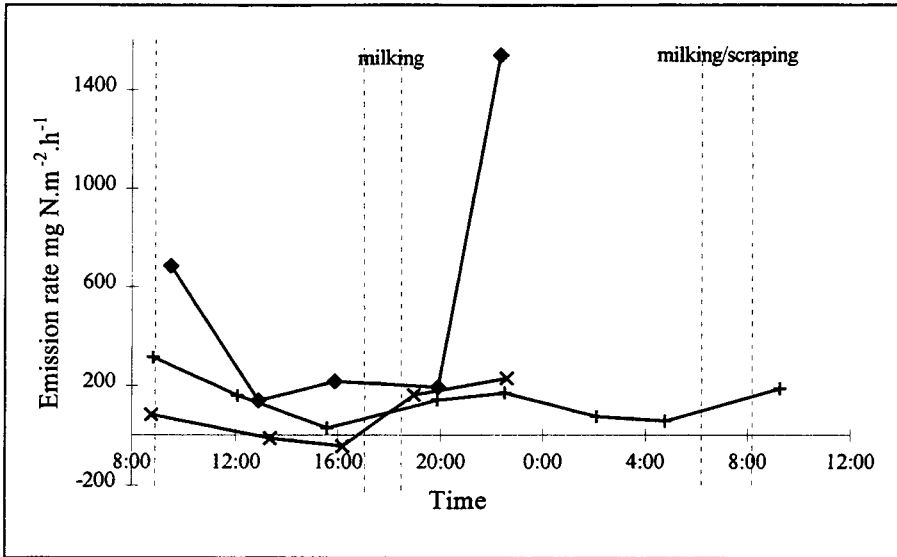

Figure 2.  
Diurnal pattern of  $\text{NH}_3$  emission from dairy cattle collecting yard

Emissions measured using the dynamic chambers were greater than those using the Lindvall hood in the winter period. However, this may have been due to the relatively high ambient temperatures during the dynamic chamber measurements compared to those of the previous winter when the Lindvall hood was used. Taking a mean emission value of  $6.5 \text{ g N.cow}^{-1}.\text{d}^{-1}$ , annual emission per dairy cow would be  $2.4 \text{ kg N}$ , representing over 10 % of the  $\text{NH}_3\text{-N}$  emission from a dairy cow as estimated recently by Pain *et al.* (1998), showing yard areas to be a significant source of  $\text{NH}_3$  emissions.

### **Methane and Nitrous Oxide**

Emission rates of  $\text{CH}_4$  from the collecting yard were variable. Emission rates from the clean yard following scraping were low ( $<100 \mu\text{g.m}^{-2}.\text{h}^{-1}$ ) and sometimes negative indicating deposition of  $\text{CH}_4$ . However, following evening milking emission rates increased as  $\text{CH}_4$  was emitted from dung pats and dirtied areas, with mean emission rates from the yard of up to  $1000 \mu\text{g.m}^{-2}.\text{h}^{-1}$  being recorded. The pattern of emission from the six chambers over a 24 h period is shown in Figure 3. Again, rates were very low from the clean yard, but were much greater following evening milking, when the greatest emission rates were recorded from dung pats, followed by dirtied areas with lowest emissions from clean looking areas of the yard. The emission rates from the dung pats were similar to those reported by Yamulki *et al.* (1998). From the 24 h measurement, mean emission rate was estimated as  $1.9 \text{ mg.m}^{-2}.\text{d}^{-1}$ , or  $2.1 \text{ mg.cow}^{-1}.\text{d}^{-1}$ . Emission from yards would be fairly insignificant

compared with total emission per dairy cow, where enteric fermentation accounts for 90 % of emission (Chadwick *et al.*, 1998).

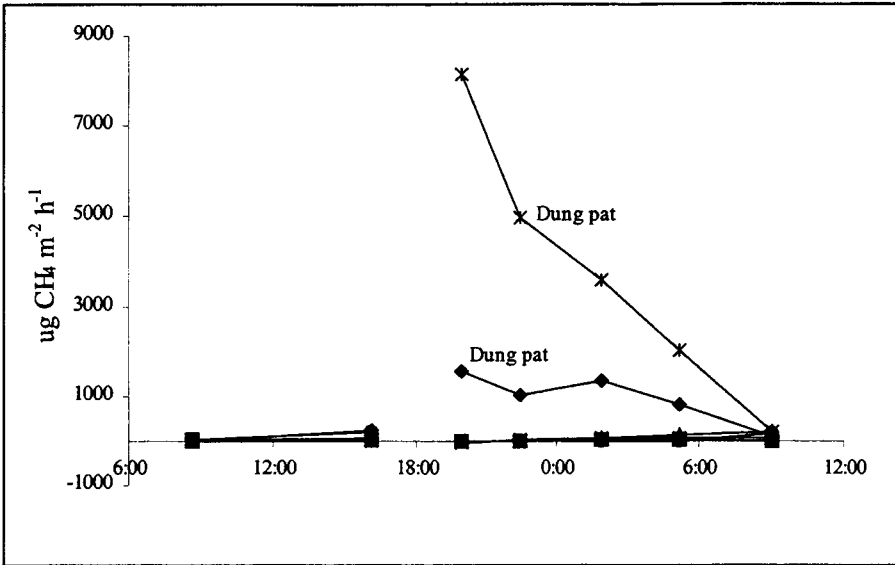

Figure 3.  
Diurnal pattern of CH<sub>4</sub> emission from dairy cattle collecting yard

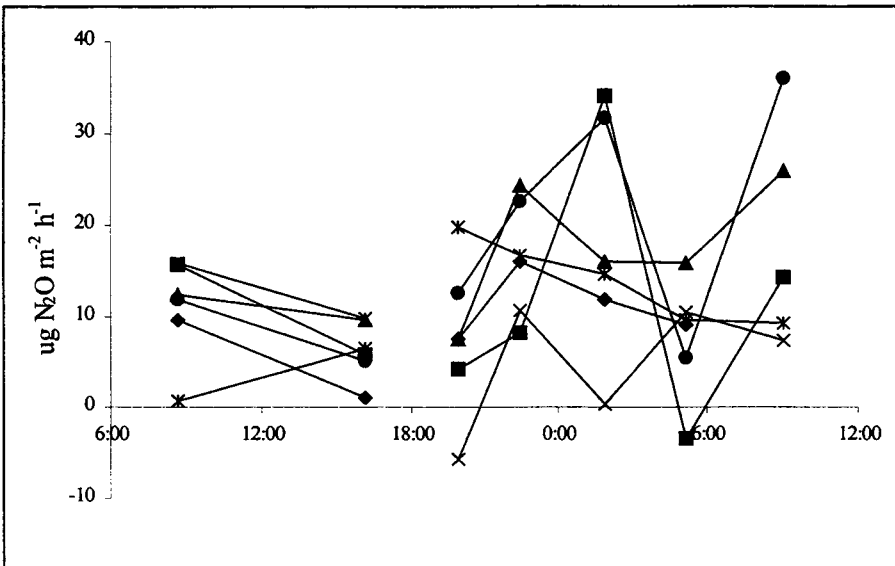

Figure 4.  
Diurnal pattern of N<sub>2</sub>O emission from dairy cattle collecting yard.

Emission rates of N<sub>2</sub>O were low and very variable. Figure 4 shows emission rates from the six chambers over a 24 h period. Emission rates were not related to the presence or absence of dung pats but, as for ammonia emission, would be more related to the presence of urine, being the major source of inorganic N. From the 24 h measurement, mean emission rate from the collecting yard was estimated as 0.2 mg N.m<sup>-2</sup>.d<sup>-1</sup>. N<sub>2</sub>O emission from yards would form a very small proportion of total N<sub>2</sub>O emission from agriculture (Chadwick *et al.*, 1998).

### **Future work**

Measurement of gaseous emissions will continue throughout the year on the dairy collecting yard at Oaklands Farm to assess seasonal changes. Measurements are also being made on other dairy farms. Measurements will also be made on other yard areas, such as feeding areas or walkways, so that an attempt can be made to estimate total emission from yard areas. Factors such as surface type and condition and management practice will be investigated.

### **Acknowledgements**

The authors thank Mr and Mrs D E Headon for allowing measurements to be made at Oaklands Farm and R A Johnson for technical assistance with the wind tunnel experiments. The work was funded by the Ministry of Agriculture Fisheries and Food. The Institute is supported by the Biotechnology and Biological Sciences Research Council.

### **References**

- Ball, P. R., Keeney, D. R., Theobald, P. W. and Nes, P.** (1979). Nitrogen balance in urine-affected areas of a New Zealand pasture. *Agronomy Journal* 71, 309-314.
- Ball, P. R. and Ryden, J. C.** (1984). Nitrogen relationships in intensively managed temperate grasslands. *Plant and Soil* 76, 23-33.
- Braam, C. R., Ketelaars, J. J. M. H. and Smits, M. C. J.** (1997). Effects of floor design and floor cleaning on ammonia emission from cubicle houses for dairy cows. *Netherlands Journal of Agricultural Science* 45, 49-64.
- Chadwick, D. R., Sneath, R. W., Phillips, V. R. and Pain, B. F.** (1998). Nitrous oxide and methane emissions from the UK agricultural livestock sector. RAMIRAN'98. This Conference Proceedings.
- Dar, G. H. and Tandon, S. M.** (1987). Response of a cattle dung fermentation to nickel. *Biological Wastes* 22, 261-268.

**Jarvis, S. C., Lovell, R. D. and Panayides, R. (1995).** Patterns of methane emission from excreta of grazing animals. *Soil Biology and Biochemistry* 27, 1581-1588.

**Kroodsma, W., Huis in't Veld, J. W. H. and Scholtens, R. (1993).** Ammonia emission and its reduction from cubicle houses by flushing. *Livestock Production Science* 35, 293-302.

**Lindvall, T; Noren, O. and Thyselius, L. (1974).** Odour reduction for liquid manure systems. *Transactions of the American Society of Agricultural Engineers* 17, 508-512.

**Lockyer, D. R. (1984).** A system for the measurement in the field of losses of ammonia through volatilisation. *Journal of the Science of Food and Agriculture* 35, 837-848.

**Lockyer, D. R. and Whitehead, D. C. (1990).** Volatilization of ammonia from cattle urine applied to grassland. *Soil Biology and Biochemistry* 22, 1137-1142.

**MacDiarmed, B. N. and B. R. Watkin (1972).** The cattle dung patch. 2. Effect of a dung patch on the chemical status of the soil, and ammonia nitrogen losses from the patch. *Journal of the British Grassland Society* 27, 43-48.

**Oenema, O., Velthof, G. L., Yamulki, S. and Jarvis, S. C. (1997).** Nitrous oxide emissions from grazed grassland. *Soil Use and Management* 13, 288-295.

**Pain, B. F.; Weerden van der, T. J.; Chambers, B. J.; Phillips, V. R. and Jarvis, S. C. (1998).** A new inventory for ammonia emissions from UK agriculture. *Atmospheric Environment* 32, 309-313.

**Ryden, J. C., Whitehead, D. C., Lockyer, D. R., Thompson, R. B., Skinner, J. H. and Garwood, E. A. (1987).** Ammonia emission from grassland and livestock production systems in the UK. *Environmental Pollution* 48, 173-184.

**Svensson, L. (1994).** A new dynamic chamber technique for measuring ammonia emissions from land-spread manure and fertilizers. *Acta Agriculturae Scandinavica, Section B, Soil and Plant Science*, 44, 35-46.

**Vertregt, N. and Rutgers, B. (1987).** Ammonia volatilization from urine patches in grassland. In: Neilsen, V. C., Voorburg, J. H. and L'Hermite, P. (eds) *Volatile Emissions from Livestock Farming and Sewage Operations*. Elsevier, London, pp. 85-91.

**Yamulki, S., Jarvis, S. C. And Owen, P.** Methane emission and uptake from soils as influenced by excreta deposition from grazing animals. *Journal of Environmental Quality* (in press).

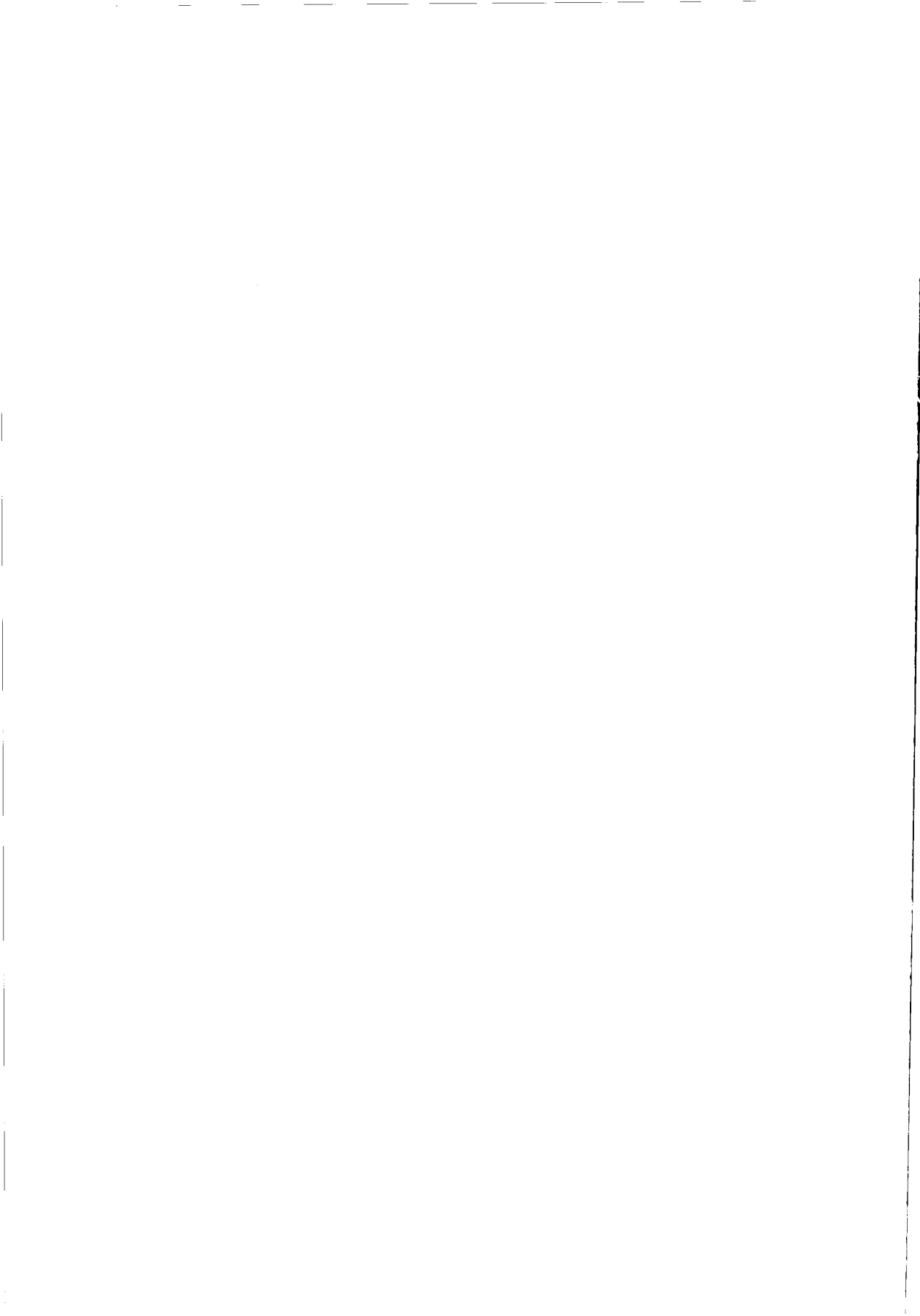

# Emissions of NH<sub>3</sub>, N<sub>2</sub>O and CH<sub>4</sub> from a tying stall for milking cows, during storage of farmyard manure and after spreading

*Emissions de NH<sub>3</sub>, N<sub>2</sub>O et CH<sub>4</sub> au cours du stockage de déjections solides (vaches laitières) et lors de l'épandage.*

**Amon B., Amon Th., Boxberger J.**  
Institut für Land, Umwelt-und Energietechnik,  
Universität für Bodenkultur.  
A-1190 Wien. Austria  
E-mail : kiesslin@edv2.boku.ac.at

**Pöllinger A.**  
Bundesanstalt für alpenländische  
Landwirtschaft,  
A-8952 Irding. Austria.

## Abstract

*At the Institute of Agricultural and Environmental Engineering (ILUET) emission measurements are carried out with the aim to find factors influencing the amount of emissions and means to reduce emissions from different agricultural sources. Measurements are mainly performed on solid manure systems. All sectors of animal husbandry are investigated. This enables calculations of emissions for the whole management system including housing, storage and spreading of manure. Concentrations of NH<sub>3</sub>, N<sub>2</sub>O, CO<sub>2</sub> and CH<sub>4</sub> are analyzed by a high resolution FTIR spectroscope. To determine the emission rate the ILUET has developed a large open-dynamic-chamber which can be put over the emitting surfaces in the housing, on manure heaps and after spreading of manure.*

*In the housing system there was nearly no difference in CH<sub>4</sub> and NH<sub>3</sub> emissions between the liquid and the solid manure system. N<sub>2</sub>O emissions were higher in the liquid manure system. NH<sub>3</sub> and N<sub>2</sub>O emissions showed a clear dependency on the season, CH<sub>4</sub> emissions were mainly caused by ruminal fermentation. During storage and after spreading of the solid manure the compost emitted more NH<sub>3</sub> than the anaerobically stored solid manure. The anaerobically stored solid manure emitted much more N<sub>2</sub>O and CH<sub>4</sub> than the compost.*

Keywords : emission measurement, milking cows, ammonia, methane, N<sub>2</sub>O.

## Résumé

Des mesures d'émissions gazeuses sont réalisées à l'Institut d'Ingénierie pour l'Agriculture et l'Environnement (ILUET) afin de déterminer les facteurs influençant ces émissions et les moyens de les réduire à partir des différentes sources agricole. Les mesures sont effectuées principalement sur les déjections gérées sous forme solide. Toutes les étapes du système d'élevage sont étudiées, ce qui

permet de calculer les émissions pour l'ensemble du système de gestion des déjections notamment le bâtiment, le stockage et l'épandage.

Les concentrations en  $\text{NH}_3$ ,  $\text{N}_2\text{O}$ ,  $\text{CO}_2$  et  $\text{CH}_4$  sont déterminées par spectroscopie FTIR. Afin d'obtenir les taux d'émissions, notre institut a développé une grande chambre dynamique ouverte qui peut ainsi être placée au dessus des surfaces d'émission dans le bâtiment, sur fumier en tas ou après épandage au champ.

Dans le bâtiment on n'observe pas de différence sur les émissions de  $\text{CH}_4$  et  $\text{NH}_3$  selon le mode fumier ou lisier. Les émissions de  $\text{N}_2\text{O}$  étaient plus importantes dans le système avec lisier. Les émissions de  $\text{NH}_3$  et  $\text{N}_2\text{O}$  sont très dépendantes de la saison, alors que les émissions de  $\text{CH}_4$  sont principalement issues des fermentations entériques par les ruminants.

Au cours du stockage et consécutivement à l'épandage de déjections solides compostées, les pertes par volatilisation de  $\text{NH}_3$  sont supérieures à celles obtenues avec déjections solides gérées en conditions anaérobies. Par contre, les déjections gérées en conditions anaérobies émettent plus de  $\text{N}_2\text{O}$  et  $\text{CH}_4$  que le compost.

Mots-clés : mesure émissions, vaches laitières, ammoniac, méthane,  $\text{N}_2\text{O}$ .

## 1. Introduction

At the Institute of Agricultural and Environmental Engineering (ILUET) emission measurements are carried out with the aim to find factors influencing the amount of emissions and means to reduce emissions from different agricultural sources. Measurements are mainly performed on solid manure systems. All sectors of animal husbandry are investigated. This enables calculations of emissions for the whole management system including housing, storage and spreading of manure.

In Austria most of the cows are housed in tying stalls with liquid or solid manure (KONRAD 1994). There is little knowledge on the amount of emissions from this housing system.

Farmyard manure can either be anaerobically stored or aerobically composted. Most of the investigations that have been carried out so far concentrated on ammonia emissions from composted farmyard manure (DEWES 1996, RÖMER ET AL. 1994). Recently also  $\text{N}_2\text{O}$  and  $\text{CH}_4$  emissions have been included in the measurements on the laboratory scale (e.g. HÜTHER ET AL. 1997, OSADA ET AL. 1997). Emission measurements should be carried out under field conditions and should include all ecologically harmful gases. As the way of storing farmyard manure influences the change of manure composition (esp.  $\text{NH}_4$  content) and as the composition of the farmyard manure influences the amount of ammonia

emissions after spreading, the emissions during storage and after spreading of the manure should be included in the investigations.

## 2. Experimental

If the emission rate is to be determined, gas concentration and air flow have to be known. Concentrations of  $\text{NH}_3$ ,  $\text{N}_2\text{O}$  and  $\text{CH}_4$  are analysed by a high resolution FTIR spectroscope. In closed stables with a central exhaust fan, the ventilation rate is measured with a measuring fan that covers the whole cross-section of the central exhaust fan. For the determination of the air flow over manure storages and during and after spreading of manure the ILUET has developed a large open dynamic chamber (fig. 1, AMON ET AL. 1997).

The mobile chamber covers an area of  $27 \text{ m}^2$  and can be built upon emitting surfaces in the animal housing, on manure storages and over manure spread areas. Fresh air enters the chamber at the front. In the chamber the fresh air accumulates the emissions and leaves the chamber on the other side. Gas concentrations are measured alternating in the incoming and in the outgoing air. The difference between incoming and outgoing air can be traced on emissions from the substrate inside the chamber. The exhaust fan at the end of the chamber can vary the air flow between  $1.000$  and  $11.000 \text{ m}^3/\text{h}$ . The air flow is recorded continuously by a measuring fan. At the front of the chamber a closed meshed net serves as a wind shield. A flow rectifier is installed at the end of the chamber. A funnel diminishes the cross-section of the chamber to that of the exhaust fan. The large open-dynamic-chamber has little influence on the natural conditions inside the chamber. The continuous air flow prevents heating up inside the chamber.

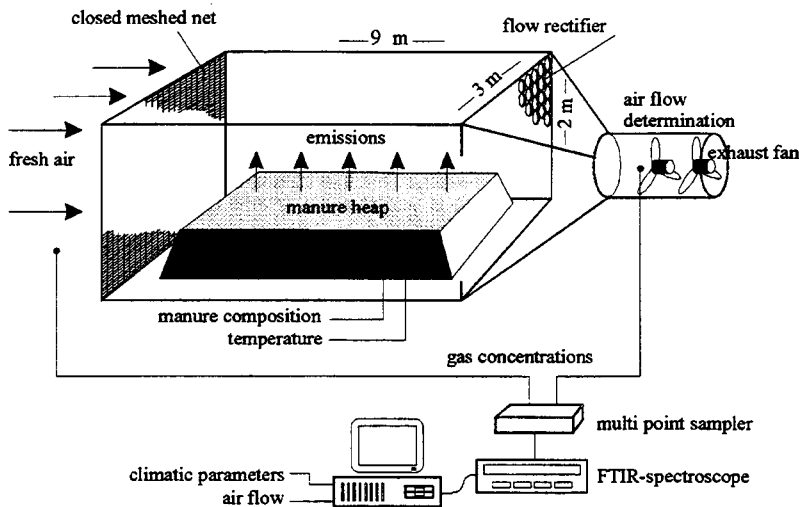

Figure 1.  
Large open dynamic chamber developed by the ILUET



## 2.1. Emissions from a tying stall for milking cows

Emissions of  $\text{NH}_3$ ,  $\text{N}_2\text{O}$  and  $\text{CH}_4$  were measured from a tying stall with dung grid (slurry based system) for 12 milking cows. The housing was ventilated by a central exhaust fan in which ventilation rate and gas concentrations could be measured. Feed intake, feed composition, weight, milk yield, and temperature and humidity in the housing were registered. The slurry based system was changed into a straw based system for two weeks during each measurement campaign. Wooden boards were placed upon the dung grid and 2 kg of straw per LU were littered down. The solid manure was removed by hand twice a day. The measurement campaigns were repeated in every season of the year to get an overview over the course of emissions during the year.

## 2.2. Emissions during composting and anaerobically storage of farmyard manure

From June to September 1996 a comparison between emissions from anaerobically stored and aerobically composted farmyard manure from a tying stall for milking cows was carried out. Two heaps of farmyard manure (each about 3.5 t) were stored on concrete slabs with a drainage system. Seepage water emissions during storage were collected and analysed for their N content. Table 1 shows the composition of the composted and the anaerobically stored farmyard manure and the mean temperature inside the manure heaps. The large open-dynamic-chamber was moved from one heap to the other three times a week to measure the emissions.

	DM [%]	$\text{N}_t$ [kg/t]	$\text{NH}_4\text{-N}$ [kg/t]	C/N	pH	temp. [°C]
composted FYM	28.3	6.60	1.10	14	7.55	45.0
anaerobically stored FYM	20.4	6.39	1.17	14	7.43	35.3

Table 1.

*Composition of the FYM and mean temperature inside the manure heaps*

One heap was composted aerobically, which means it was turned seven times during the storage period. The turning was performed by hand. The large open-dynamic-chamber was built up over the compost and collected the emissions during and after the turning. The other heap was stored anaerobically. No manipulations were performed during the storage period.

## 2.3. Emissions after spreading of farmyard manure

After the storage period the large open-dynamic-chamber was built up on grassland and the composted and the anaerobically stored farmyard manure were spread in the chamber. The amount of spreaded manure was equivalent to 20 t/ha.

Emissions during and after spreading were also measured so that the sum of emissions (storing, turning, loading and spreading) could be determined.

### 3. Results

#### 3.1. Emissions from a tying stall for milking cows

Table 2 shows the emissions measured in the tying stall for milking cows with slurry and straw based system. The mean emissions of all three gases in course of the year showed no statistical difference between both housing systems (t-Test,  $\alpha \leq 0.05$ ). However there was a clear variation in the emissions in course of the year.  $\text{NH}_3$  and  $\text{N}_2\text{O}$  emissions were dependent on the season: the higher the temperature the higher these emissions.  $\text{CH}_4$  emissions also changed throughout the year but those changes did not show a correlation with the season. They were caused by the different milk yield and feed intake of the cows.

	$\text{NH}_3$ [g/LU*d]			$\text{N}_2\text{O}$ [mg/LU*d]			$\text{CH}_4$ [g/LU*d]		
	min	max	mean	min	max	mean	Min	max	mean
slurry based system (n $\approx$ 860)	4.0	6.1	5.7	141.6	1188.0	609.6	170.4	218.4	194.4
straw based system (n $\approx$ 860)	3.9	7.4	5.8	300.0	1135.2	619.2	184.8	232.2	194.4

*Table 2.*  
*Emissions of  $\text{NH}_3$ ,  $\text{N}_2\text{O}$  and  $\text{CH}_4$  from a tying stall for milking cows*

Calculations of the amount of  $\text{CH}_4$  emissions that were caused by ruminal fermentation (KIRCHGESSNER ET AL. 1991) showed, that in both housing systems about 80% of the emissions came from ruminal fermentation. The housing system did not influence the  $\text{CH}_4$  emissions. Ruminal fermentation is a major source of methane emissions (KINSMAN ET AL. 1995, HEYER 1994).

Ammonia emissions were comparatively low (tab. 2). ISERMANN (1994) gives mean ammonia emissions for housing systems for milking cows of 16.56 g  $\text{NH}_3$ /LU\*d. This value was mainly derived from emissions of loose housing systems. GROENESTEIN & MONTSMA (1991) found ammonia emissions of 9.0-14.0 g  $\text{NH}_3$ /LU\*d. Their measurements were carried out in tying stalls for milking cows in the Netherlands.

Due to the lack of data the  $\text{N}_2\text{O}$  emissions can not be compared with values given in the literature. Their share of the total N emissions was about 5-10%. However  $\text{N}_2\text{O}$  emissions play an important role in the greenhouse effect and have to be reduced.

### 3.2. Emissions during storage and after spreading of farmyard manure

Table 3 shows the ammonia emissions during storage and after spreading of composted and anaerobically stored farmyard manure. The compost emitted more NH<sub>3</sub> than the anaerobically stored farmyard manure. The periods of turning contributed with 4% to the total emissions. Most of the ammonia was lost during the first two weeks of storage. After spreading of the compost no ammonia emissions were measured due to the fact, that there was no NH<sub>4</sub> in the compost. Whereas about 35% of the ammonia losses from the anaerobically stored farmyard manure were measured after spreading. The higher NH<sub>4</sub> content after the storage period resulted in higher ammonia emissions after spreading.

	NH <sub>3</sub> -losses [g NH <sub>3</sub> /t FM <sup>a</sup> ]			
	Storage	turning	spreading	Sum
composted FYM	643.3	27.2	-	670.5
anaerobically stored FYM	162.7	-	85.3	248.0

<sup>a</sup> FM = fresh matter

Table 3.

*Ammonia losses during storage and after spreading of composted and anaerobically stored farmyard manure*

Table 4 shows the total N losses of composted and anaerobically stored farmyard manure. The N losses of the compost amounted to 10.84% of the nitrogen content of the farmyard manure at the beginning of the storage period. From the anaerobically stored farmyard manure 7.79% of the total N were lost via NH<sub>3</sub>, N<sub>2</sub>O and N in the seepage water NO<sub>3</sub>, NH<sub>4</sub>. The shares of NH<sub>3</sub>-N and N in the seepage water were nearly equal. 77% of the N losses from the compost were emitted as NH<sub>3</sub>. The compost emitted less N<sub>2</sub>O and less N in the seepage water than the anaerobically stored farmyard manure.

	N losses [g N/t FM <sup>a</sup> ]			Sum	% of total N
	NH <sub>3</sub> -N	N <sub>2</sub> O-N	N in seepage water		
composted FYM	552.2	23.9	141.5	717.6	10.84
anaerobically stored FYM	205.7	36.5	260.1	502.3	7.79

<sup>a</sup> FM = fresh matter

Table 4.

*N losses during storage and after spreading of composted and anaerobically stored farmyard manure*

In table 5, the sum of greenhouse gas emissions from composted and anaerobically stored solid manure is shown. To compare the global warming potential of the two treatments, N<sub>2</sub>O and CH<sub>4</sub> emissions are given in CO<sub>2</sub> equivalents, that means relative to the global warming potential of CO<sub>2</sub> (EK 1995).

	Greenhouse gas emissions [kg CO <sub>2</sub> equiv./t FM <sup>a</sup> ]		
	N <sub>2</sub> O emissions	CH <sub>4</sub> emissions	Sum
composted FYM	8.87	4.96	13.83
anaerobically stored FYM	13.65	47.85	61.50

<sup>a</sup> FM = fresh matter

*Table 5.  
Greenhouse gas emissions of composted  
and anaerobically stored farmyard manure*

Greenhouse gas emissions from the anaerobically stored farmyard manure were about 4.5 times higher than from the composted farmyard manure. Methane emissions contributed about 78% to the total emissions. Methane is formed under anaerobic, warm conditions, when degradable C is available. Conditions in the anaerobically stored farmyard manure favoured methane production. Methane emissions were observed during the whole storage period and had not come to their end by the end of storage. They were strongly dependent on the temperature inside the manure heap. N<sub>2</sub>O emissions also occurred during the whole storage period.

#### 4. Conclusions

The measurements carried out by the ILUET have shown, that NH<sub>3</sub> and N<sub>2</sub>O emissions from tying stalls for milking cows in Austria are low. Methane emissions from the animal housing were mainly caused by ruminal fermentation.

During storage and after spreading of farmyard manure substantial differences concerning NH<sub>3</sub>, N<sub>2</sub>O and CH<sub>4</sub> emissions were observed with composted and anaerobically stored FYM. The compost emitted more NH<sub>3</sub> than the anaerobically stored FYM. About one third of the NH<sub>3</sub> emissions from the anaerobically stored FYM occurred after spreading. It is very important to include the spreading in the calculations of the emissions. Total N losses were on a low level with both storage systems. Greenhouse gas emissions (N<sub>2</sub>O and CH<sub>4</sub>) were much higher from the anaerobically stored farmyard manure than from the compost. As they are also ecologically harmful gases they have to be considered when judging the manure treatments and have to be reduced.

- It is important to take into consideration all sectors of animal husbandry if mitigation options for ecologically harmful gases are to be found. The distribution of the emissions to the emitting sources differs in dependency on the treatment. E.g. in the investigations presented in this paper 80.6% of the ammonia emissions from the composting system occurred during the storage period and 19.4% came from the animal housing. With the anaerobic storage of the farmyard manure the distribution of ammonia emissions was quite different: 46.1% of the emissions came from the animal housing, 35.4% from the storage and 18.5% emitted after spreading of the farmyard manure. If the spreading had not been included in the calculations, the NH<sub>3</sub> emissions would have been underestimated.

## 5. References

[1] AMON, B., AMON, TH., BOXBERGER, J., PÖLLINGER, A., ZAUSSINGER, A. Entwicklung einer Meßeinrichtung zur Erfassung umweltrelevanter Gasemissionen. *Die Bodenkultur* 47, 4 (1997), S. 247-253.

[2] DEWES, T. Biotisch und abiotisch bedingte NH<sub>3</sub>-Emissionen während der Lagerung von Stallmist. *Agribiological Research* 49, 2-3 (August 1996), S. 203-210.

[3] ENQUÊTE-KOMMISSION SCHUTZ DER ERDATMOSPHÄRE DES 12. DEUTSCHEN BUNDESTAGES, Hrsg. Mehr Zukunft für die Erde: Nachhaltige Energiepolitik für dauerhaften Klimaschutz (Bonn 1995), Deutscher Bundestag, Economica Verlag. Schlußbericht der Enquête.

[4] GROENESTEIN, C.M., MONTSMA, H. Field research into the ammonia emission from animal housing systems: Tying stall for dairy cattle. Report 91-1002, DLO, Wageningen, 1991.

[5] HEYER, J. Methan. In *Studienprogramm Landwirtschaft*, Enquête-Kommission Schutz der Erdatmosphäre des Deutschen Bundestages, Hrsg. Economica Verlag GmbH, Bonn, 1994, Kap. C, S. 1-91.

[6] HÜTHER, L., SCHUCHARDT, F., WILLKE, T. Emissions of ammonia and greenhouse gases during storage and composting of animal manures. In *Ammonia and Odour Control from Animal Production Facilities* (1997), EurAgEng, Hrsg., S. 327-334. International Symposium, 6.-10. October 1997, Vinkeloord, The Netherlands.

[7] **ISERMANN, K.** Ammoniak-Emission der Landwirtschaft, ihre Auswirkungen auf die Umwelt und ursachenorientierte Lösungsansätze sowie Lösungsaussichten zur hinreichenden Minderung. In *Studienprogramm Landwirtschaft*, Enquête-Kommission Schutz der Erdatmosphäre des Deutschen Bundestages, Hrsg. Economica Verlag GmbH, Bonn, 1994, Kap. E, S. 1-250. Band 1. Landwirtschaft. Teilband I.

[8] **KINSMAN, R., SAUER, F.D., JACKSON, H.A., WOLYNETZ, M.S.** Methane and carbon dioxide emissions from dairy cows in full lactation monitored over a six-month period. *Journal of Dairy Science* 78 (1995). S. 2760—2766.

[9] **KIRCHGESSNER, M., WINDISCH, W., MÜLLER, H.L., KREUZER, M.** Release of methane and of carbon dioxide by dairy cattle. *Agribiological Research* 44 (1991), S. 91-102.

[10] **KONRAD, S.** Erhebungen zur Tierhaltung in Österreich, Forschungsprojekt L499/87, Bundesministerium für Land- und Forstwirtschaft, Wien, 1994.

[11] **OSADA, T., KURODA, K., YONAGA, M.** N<sub>2</sub>O, CH<sub>4</sub> and NH<sub>3</sub> emissions from composting of swine waste. In *Ammonia and Odour Control from Animal Production Facilities* (1997), EurAgEng, Hrsg., S. 373-380. International Symposium, 6.-10. October 1997, Vinkeloord, The Netherlands.

[12] **RÖMER, G., BOEKER, P., SCHULZE-LAMMERS, P.** Ammoniakemissionen von Festmist. *Landtechnik* 49, 2 (1994), S. 72-73.

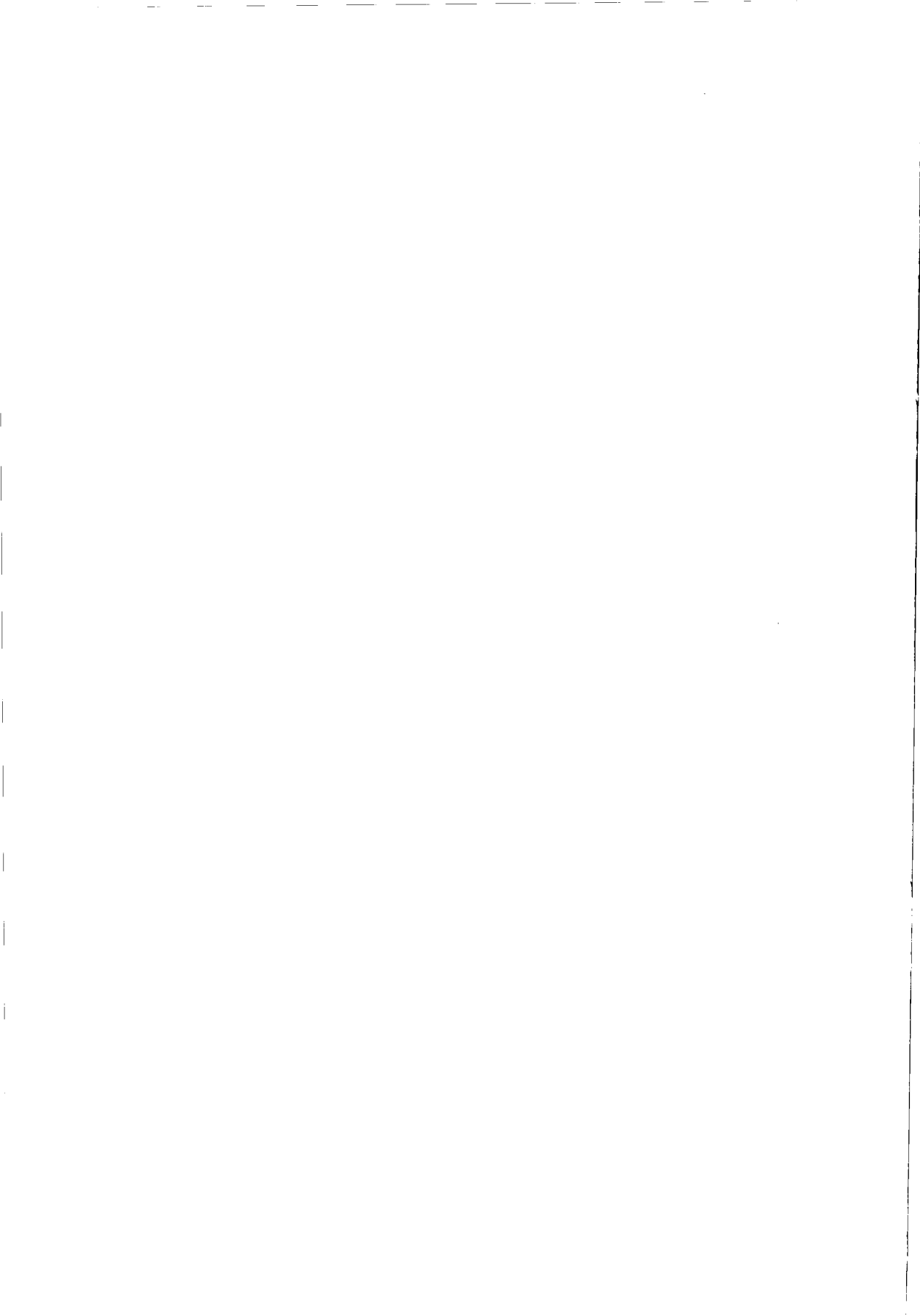

## **Methane and nitrous oxide emissions from UK agricultural livestock.**

*Inventaire des émissions de méthane et de protoxyde d'azote  
issues des activités d'élevage en Grande-Bretagne.*

**D.R. Chadwick, B.F. Pain**  
Institute of Grassland and Environmental  
Research (IGER),  
North Wyke, Okehampton,  
Devon. EX20 2SB, UK  
E-mail : david.chadwick@bbsrc.ac.uk

**R.W. Sneath, V.R. Phillips**  
Silsoe Research Institute (SRI),  
Wrest Park, Silsoe, Bedfordshire.  
B45 4HS, UK.

### **Abstract**

*UK inventories for nitrous oxide (N<sub>2</sub>O) and methane (CH<sub>4</sub>) were constructed for farmed livestock in order to quantify emissions and provide information on areas where abatement practices may be potentially useful. The inventories were constructed separately using Excel spreadsheets conveniently divided into the different categories of animal, viz. cattle, pigs, sheep, poultry and deer. Emissions from grazing land and land used for conserved grass or tillage crops were included for completeness. N<sub>2</sub>O and CH<sub>4</sub> emissions from each of the animal categories were further divided into a) emissions from buildings, b) manure stores and c) following application of manures to the land. Where possible we made our own measurements, i.e. under UK conditions but took literature values where there was little or no other data available. Our inventory estimates were 21.1 kt N<sub>2</sub>O per year and 845.0 kt CH<sub>4</sub> per year. Because of the approach we estimate the error associated with the total N<sub>2</sub>O emissions to be ± 50%. The emission factors we used are discussed in this paper, as are potential abatement practices.*

### **Résumé**

L'augmentation de la concentration atmosphérique globale du protoxyde d'azote (N<sub>2</sub>O) au cours de la dernière décennie est due à l'utilisation plus intensive des engrais chimiques et engrais de ferme, tandis que celle de méthane (CH<sub>4</sub>) (produit dans les processus de méthanogénèse) est le résultat de l'augmentation du nombre d'animaux ruminants et de la culture de riz. Ces pertes gazeuses se produisent à chaque étape dans le cycle de production, par exemple, dans les bâtiments pendant le stockage et suivant l'application du fumier aux champs. Cet article décrit les pertes relatives de N<sub>2</sub>O et CH<sub>4</sub> de chacun de ces compartiments.



Les émissions de  $N_2O$  et  $CH_4$  ont été mesurées dans les bâtiments de ventilation forcée et naturelle. Les pertes pendant le stockage du fumier ont été mesurées en utilisant des méthodes de « tunnel » et des méthodes micro-météorologiques, alors que les émissions suivant l'épandage sur le sol ont été mesurées en utilisant une combinaison de méthodes de cloche ou boîte à couvert statique et active.

La production totale de  $CH_4$  en 1995 était de l'ordre de 846 kt, dont 75% venait de la fermentation entérique des vaches. Pour la même période, le total des émissions de  $N_2O$  était de 18,3 kt, dont le stockage (5,7 kt) et l'application des engrais chimiques aux champs (5,4 kt) sont les sources principales.

A cause de la grande influence de la fermentation entérique et des engrais chimiques sur les inventaires de  $CH_4$  et de  $N_2O$ , respectivement, il existe des incertitudes considérables dans ces estimations. Cependant, ces inventaires suggèrent qu'afin de diminuer les pertes de  $CH_4$  une manipulation de l'alimentation des animaux peut être nécessaire, alors que les émissions de  $N_2O$  peuvent être diminuées par une utilisation plus efficace des engrais chimiques.

## 1. Introduction

Methane is the second most important greenhouse gas after  $CO_2$ , contributing approximately 20% to global warming (Bouwman, 1990), and is produced primarily by microbial degradation of organic material under anaerobic conditions, e.g. in the rumen during enteric fermentation. Manures contain biodegradable C, often in an anaerobic conditions, thus favouring methanogenesis and the emission of  $CH_4$ . Methane emissions have been reported from manure stores (Husted, 1993) and following slurry applications to land (Chadwick *et al.*, 1997). Until recently,  $CH_4$  emissions from livestock waste have been largely neglected, although  $CH_4$  budgets given by Safely *et al.* (1992) revealed that such wastes may contribute to up to 10% of the total anthropogenic emission of  $CH_4$ . In the UK the estimated annual production of solid manures and slurries is 85 million tonnes (Pain *et al.*, 1998), therefore the livestock sector represents a large potential source of  $N_2O$  and  $CH_4$ .

Nitrous oxide is a potent greenhouse gas and is also implicated in depletion of stratospheric ozone (Cicerone, 1987). Agriculture is partially responsible for the rise in atmospheric concentration of  $N_2O$ , 0.2-0.3% per annum, observed in recent years (Bouwman, 1990).  $N_2O$  is the product of both nitrification (Bremner and Blackmer, 1978) and denitrification (Firestone and Davidson, 1989) and is produced at any stage of livestock production when conditions become favourable. e.g. manure applications to land return biodegradable carbon (C), a nitrifiable nitrogen (N) source (principally ammonium) and moisture to the soil, thus favouring nitrification and denitrification. Nitrous oxide emissions have been shown to increase following application of manures to agricultural soils (Paul *et al.*, 1993; Sommer *et al.* 1996 and Chadwick, 1997). There is less information on emissions

of N<sub>2</sub>O from other stages of livestock production, viz. animal houses and manure stores.

This paper describes 2 UK emission inventories, for N<sub>2</sub>O and CH<sub>4</sub> from farmed livestock, which have been constructed in a transparent form on spread-sheets which can be easily updated as new information becomes available. They have been compiled using, as far as possible, direct experimental data gathered under UK conditions. Literature values for emission factors have also been used to corroborate our measurements and also provide missing emission factors where appropriate. We also identify potential abatement practices.

## **2. Materials and methods**

### **Inventory construction**

The inventories were constructed on computer spreadsheets (EXCEL 5.0) and conveniently partitioned into emissions from each livestock group in the UK, i.e. cattle, pigs, poultry, sheep and deer. For completeness, emissions from conserved grassland and tillage crops were included, as they provide feedstuffs for livestock enterprises. Each livestock group was further divided into emissions from animal houses, manure stores and following land spreading of manures. Animal numbers from the June 1996 census were used (HMSO, 1997), the only exceptions were poultry and farmed deer. The census data for 1996 were not available for these classes of animals therefore 1993 numbers (HMSO, 1994) were used for poultry and 1995 numbers for deer (HMSO, 1996).

### **Emission factors**

The construction of the inventories required the input of emission factors (EFs) for N<sub>2</sub>O and CH<sub>4</sub>. For housing, the EF were expressed as g N<sub>2</sub>O or CH<sub>4</sub> lu<sup>-1</sup> d<sup>-1</sup>, where lu = livestock unit or 500 kg liveweight. Losses from manure stores were expressed as g N<sub>2</sub>O or CH<sub>4</sub> m<sup>-3</sup> slurry or t<sup>-1</sup> FYM. Emission factors for land spreading were in g N<sub>2</sub>O or CH<sub>4</sub> m<sup>-3</sup> slurry or t<sup>-1</sup> FYM.

### **Determination of emission factors from animal houses**

Long-term emissions (several weeks) of N<sub>2</sub>O and CH<sub>4</sub> were quantified from a fattening piggery (300 pigs) and a dairy cow house (100 cows), using automated gas chromatography (GC) (Sneath *et al.*, 1997). Also, continuous measurements over a 24 hour period were made from a large number of different types of pig, poultry and cattle buildings, under both summer and winter conditions using infra-red analyses (Sneath, 1996).

## **Determination of emissions from manure stores**

Since  $N_2O$  production from slurries requires nitrate to be present and slurries are extremely anaerobic, we set  $N_2O$  emissions from slurry stores and dirty water tanks at zero. However, for solid manure stores there is limited air access to the manure providing a mixture of anaerobic and aerobic zones (Kirchmann, 1985). Therefore conditions exist for both nitrification and denitrification within FYM heaps, increasing the opportunity for  $N_2O$  production. Methane production and emission is possible from both slurries and solid manures.

In this study we have used  $N_2O$  and  $CH_4$  EFs we measured from beef FYM and one for  $N_2O$  from pig FYM by Sibbsen and Lind (1993). No UK data were available for poultry manure, therefore we used the EFs calculated for a poultry building we monitored, assuming that the  $N_2O$  and  $CH_4$  were generated by the excreta and not the birds themselves. Emission rates were multiplied by the volume of manure stores, which was estimated by Nicholson and Brewer (1997).

## **Determination of land spreading emission factors**

Nitrous oxide and  $CH_4$  EFs were measured from grassland following applications of different manures at several times of the year. Typical application rates were used and emissions measured using both static and active cover boxes (Mosier, 1989). Emissions were monitored until rates of  $N_2O$  emission had decreased to background levels (untreated controls), usually between 3 and 4 weeks. Average EFs were calculated for each manure type and multiplied by the volume of each manure type applied to agricultural soils each year. We assumed that EFs for grassland and arable land were the same.

## **Emission factors for conserved grassland and tillage land**

Nitrous oxide emissions from these areas of land were estimated by multiplying the mass of ammonium nitrate, urea and 'other' N fertilisers applied each year (Burnhill *et al.*, 1994 and DANI, 1994) by the average %N loss as  $N_2O$  of N applied, as suggested in the IPCC guidelines for National Greenhouse Gas Inventories (IPCC 1997). However, we used the average fractional loss values as reviewed by Eichner (1990). These emission factors were 0.44%, 0.11% and 0.16%, for ammonium nitrate, urea and 'other' fertilisers, respectively. Methane emissions from this land were set at zero, although we recognise that some  $CH_4$  oxidation may occur.

## **Emission factors for grazing**

A grazing term was included in the cattle, pig and sheep sections of the inventory. Non-milking dairy cattle were presumed to graze for 183 days, as were beef cattle, bulls and other cattle older than one year. Calves < 6 months old and 6-12 months old graze for 90 and 150 days, respectively. The grazing time for milking cows was

reduced by 12.5% to 160 d to account for time spent in the buildings during milking and in moving between pasture and the milking parlour during the grazing season. Losses of  $N_2O$  from grazing cattle were divided into losses resulting from fertiliser applied and losses from direct excretal returns to pasture. The former term was calculated from the area of land receiving N fertilisers as categorised in the Survey of Fertiliser Practice for Great Britain (Burnhill, 1994) and the %N loss as  $N_2O$  of N applied as reviewed by Eichner (1990). This term is included in the losses of  $N_2O$  from conserved grassland.

The annual  $N_2O$  emission from excretal returns from grazing cattle, 3.1 kt, was taken from the long-term experimental data of Yalmulki *et al.* (1998) who monitored emissions from dung and urine patches. Since no direct data were available for outdoor pigs and sheep, emissions of  $N_2O$  from excretal returns were estimated by using the emission factor based on pig slurry and cattle FYM applied to grassland, respectively.

Losses of  $CH_4$  were divided into losses from enteric fermentation within the gut of ruminants and  $CH_4$  emissions from excretal returns. The EF for enteric fermentation was the same as that used for enteric fermentation within animal houses. However,  $CH_4$  emissions from excretal returns were estimated from slurry and FYM applications to land, corrected for excretal rates.

### 3. Results

#### Housing

Table 1 illustrates the  $N_2O$  and  $CH_4$  emissions from housed animals. The largest  $N_2O$  emissions result from cattle and poultry. As expected the largest methane emission is from cattle and is almost entirely the product of enteric fermentation. Our measured EF for enteric fermentation from dairy cattle,  $270 \text{ g lu}^{-1} \text{ d}^{-1}$ , is somewhat higher than the  $190 \text{ g lu}^{-1} \text{ d}^{-1}$  reported by Blaxter and Clapperton (1965) who measured  $CH_4$  emissions from individual cattle in metabolic crates, but similar to the  $260 \text{ g lu}^{-1} \text{ d}^{-1}$  reported by Kinsman *et al* (1995).

Animal category	Management system	CH <sub>4</sub> emission (kt)	% CH <sub>4</sub> loss from housing	N <sub>2</sub> O emission (kt)	% N <sub>2</sub> O loss from housing
Cattle	Dairy				
	Slurry based	148.2	40.0	0.46	9.2
	Straw based	34.9	9.4	0.11	2.2
	Beef	114.0	30.8	1.05	21.0
	Calves (dairy and beef)	46.0	12.4	0.17	3.4
Sheep	Straw based	4.6	1.2	<0.01	0.0
Pigs	Straw based	4.3	1.2	0.07	1.4
	Slurry based	17.2	4.6	0.07	1.4
Poultry	Broiler sawdust based	0.4	0.1	1.46	29.4
	Layer no bedding	0.9	0.2	0.50	10.0
	Pullets	0.1	<0.1	0.09	1.8
	Others	0.4	0.1	0.99	19.8
Deer	Straw based	0.1	<0.1	0.02	0.4
Total		371.1	100.0	4.99	100.0

*Table 1.*  
*CH<sub>4</sub> and N<sub>2</sub>O emissions from animal houses in the UK.*

### Storage

The storage losses of CH<sub>4</sub> and N<sub>2</sub>O are shown in Table 2. The greatest emissions of nitrous N<sub>2</sub>O were from the beef cattle manure and poultry manure heaps.

Animal category	Type of store	CH <sub>4</sub> emission (kt)	% CH <sub>4</sub> loss from stores	N <sub>2</sub> O emission (kt)	% N <sub>2</sub> O loss from stores
Cattle	Solid manure	32.6	77.9	3.58	63.4
	Slurry stores	1.9	4.5	0.0	0.0
Sheep	Solid manure	1.0	2.4	0.12	2.1
Pigs	Solid manure	1.9	4.5	0.05	0.9
	Slurry store	3.6	8.6	0.0	0.0
Poultry	Solid manure	0.9	2.1	1.90	33.6
Deer	Solid manure	0.0	0.0	0.0	0.0
Total		39.0	100.0	5.65	100.0

*Table 2.*  
*CH<sub>4</sub> and N<sub>2</sub>O emissions from manure stores in the UK.*

## Land spreading

Emissions of CH<sub>4</sub> and N<sub>2</sub>O following land spreading manures are summarised in Table 3. The N<sub>2</sub>O and CH<sub>4</sub> losses following landspreading of manures are relatively small with the greatest losses coming from the spreading of cattle manures. The average % N lost as N<sub>2</sub>O following applications of pig and dairy slurries were 0.4% and 0.3%, respectively. These values are similar to those reported by Paul *et al.* (1993) and Sommer *et al.* (1996). Methane losses were very short-lived following manure application as oxygen diffused into the manures.

Animal category	Type of store	CH <sub>4</sub> emissions (kt)	% CH <sub>4</sub> loss from spreading	N <sub>2</sub> O emission (kt)	% CH <sub>4</sub> loss from spreading
Cattle	Solid manure	0.2	40.0	0.52	46.8
	Slurry	0.1	20.0	0.30	27.1
Sheep	Solid manure	<0.1	<0.1	0.03	2.7
Pigs	Solid manure	0.2	40.0	0.03	2.7
	Slurry	<0.1	<0.1	0.13	11.7
Poultry	Solid manure	<0.1	<0.1	0.10	9.0
Deer	Solid manure	<0.1	<0.1	<0.01	0.0
Total		0.5	100.0	1.11	100.0

Table 3.  
*N<sub>2</sub>O and CH<sub>4</sub> emissions following manure spreading in the UK.*

## Emissions from grazing and outdoor animals

The greatest CH<sub>4</sub> emission was from the enteric fermentation of grazing ruminants, 306.0 kt from cattle and 125.1 kt from sheep. The greatest N<sub>2</sub>O emission was also from grazing cattle, 3.17 kt, but as a result of the nitrification and denitrification of N returned to the soil in dung and urine.

## Conserved grassland and tillage land

These areas of land were considered not to be emitters of methane. There is evidence of CH<sub>4</sub> uptake by grasslands but this has not been considered in this inventory. The annual N<sub>2</sub>O emissions from different fertiliser types totalled 2.05 kt for conserved and grazed grassland and 3.01 kt for tillage land.

## Total emissions

Emissions from components of farm management are shown in Table 4. The largest components in the total emission of N<sub>2</sub>O are manure stores, 5.65 kt and fertilised land, 5.36 kt. The largest components in the total emission of CH<sub>4</sub> are housing and outdoor livestock, i.e. enteric fermentation in ruminants.

Component	CH <sub>4</sub> emission (kt)	% CH <sub>4</sub> of total loss	N <sub>2</sub> O emission (kt)	% N <sub>2</sub> O of total loss
Housing	371.3	44.0	4.99	23.6
Storage	42.0	4.9	5.65	26.8
Land application	0.5	<0.1	1.11	5.3
Fertiliser	0.0	0.0	5.36	25.4
Outdoor livestock	431.6	51.1	3.98	18.9
TOTAL	845.5	100.0	21.09	100.0

Table 4.  
*CH<sub>4</sub> and N<sub>2</sub>O emissions by farm management in the UK.*

When the inventories are broken down by livestock class (Table 5), the largest proportion of the total N<sub>2</sub>O emission is from cattle (44.4%) followed by poultry (23.9%) and the largest proportion of the total CH<sub>4</sub> emission is also from cattle (81%).

Component	CH <sub>4</sub> emission (kt)	% CH <sub>4</sub> of total loss	N <sub>2</sub> O emission (kt)	% N <sub>2</sub> O of total loss
Cattle	684.0	81.0	9.36	44.4
Sheep	130.7	15.5	0.75	3.6
Pigs	27.7	3.2	0.39	1.8
Poultry	2.7	0.3	5.04	23.9
Deer	0.3	<0.1	0.19	0.9
Conserved grassland	0.0	0.0	2.05	9.7
Tillage land	0.0	0.0	3.31	15.7
TOTAL	845.4	100.0	21.09	100.0

Table 5.  
*CH<sub>4</sub> and N<sub>2</sub>O emissions by livestock class in the UK.*

## 4. Discussion

### N<sub>2</sub>O

The N<sub>2</sub>O inventory described above identifies three sub-terms not included in earlier inventories, namely emissions from outdoor livestock, from livestock buildings and from stored manures. Nevertheless, the total annual emission is in the range of those emissions of HMSO (1997b), 9.90 kt, and Croxford (1994 unpublished MAFF work), mean of 14.32 kt (range 1.99-155.13) but much lower than that by Armstrong Brown *et al.* (1996), 103 kt.

The largest term according to inventories of Croxford (unpublished MAFF figures for 1994) and of HMSO (1997b), is the N<sub>2</sub>O emission from soils receiving mineral N fertilisers, whereas the inventory of Armstrong-Brown *et al.* (1996) indicated that N<sub>2</sub>O emissions from land applications of manures is the largest term. This difference arises

because of the different expressions used for predicting  $N_2O$  losses from these sources, viz. that up to 7.8% of the ammoniacal-N ( $NH_4^+$ -N) content of manure is emitted as  $N_2O$ -N (Jarvis and Pain, 1994) which may be a worst case scenario. From the 20 sets of field measurements made following land spreading of manures during our study the average values for the percentage of manure- $NH_4^+$ -N lost as  $N_2O$ -N were 0.64 % for slurries (n=15) and 5.90 % for solid manures (n=5).

The inventory total is very sensitive to changes in the %N lost as  $N_2O$  from soil fertilised with inorganic N fertilisers. We used the average figures for different N fertiliser types quoted by Eichner (1990) but, because of the effect of complex interactions of physical, chemical and biological variables on  $N_2O$  production and emissions from soils, the accuracy of this approach is questionable. (Bouwman, 1990). Soil management and cropping regimes and variable rainfall may have a greater effect on  $N_2O$  emissions than fertiliser type. Therefore, Bouwman (1996) recommended the use of one emission factor to cover all N fertiliser types. i.e. 1.25% of N applied ( $kg\ N\ ha^{-1}$ ). If this emissions factor is used the total  $N_2O$  loss from conservation and tillage land increases from  $5.36\ kt\ y^{-1}$  to  $23.90\ kt\ y^{-1}$  and the annual  $N_2O$  loss for UK farmed livestock increases from 21.09 kt to 39.63 kt.

The  $N_2O$  losses from grazing cattle (excretal returns) were taken from Yalmulki *et al.* (1998) who found that up to 1% of the N excreted in urine and 0.53% excreted in the dung were emitted as  $N_2O$ , respectively. A recent review by Oenema *et al.* (1997) suggests that, on average, 2% of excreted N is emitted as  $N_2O$ . Using this value in our inventory increases the total loss for grazing cattle from 3.1 kt to 7.0 kt. This term also includes the influence of soil compaction on  $N_2O$  emissions. Using the same value for the fractional loss, i.e. 2%, the N content of the excreta and the excretal rate, the  $N_2O$  emissions from outdoor pigs, initially estimated from the fractional loss following slurry applications to land, are increased from 0.03 kt to 0.20 kt. The  $N_2O$  emission estimated from grazing sheep is also increased from 0.29 kt to 1.94 kt per year using this EF of Oenema *et al.* (1997).

Our inventory was constructed in a relatively simple format with no direct consideration of the effect of the time of year, animal diet or soil type on emission factors, although we recognise that such factors are important e.g. Velthof and Oenema (1995). We used values which were based on the means of measurements taken from animal buildings, manure stores and following manure applications to the land throughout the year and which covered a range of typical animal diets, soil types and slurry application techniques. Because of the approach we estimate the error associated with the total  $N_2O$  emissions to be  $\pm 50\%$ .

## **CH<sub>4</sub>**

The  $CH_4$  inventory was dominated by emissions from enteric fermentation in cattle. Our value for this EF,  $270\ g\ lu^{-1}\ d^{-1}$ , for dairy (milking) cattle is based on the arithmetic mean of both long-term measurements (5 weeks) and many short-term (24 hours) measurement periods at commercial farms in the UK. It is evident from the literature



- that within any one class of cattle, differences in measured CH<sub>4</sub> emission rates are evident. This may be due to differences in measurement methods but it is known that diet effects enteric CH<sub>4</sub> production and also there appears to be an animal to animal variation in CH<sub>4</sub> emission rate, so measurements on large groups of animals are more desirable than measurements on single animals. Our total of 845.0 kt is somewhat lower than that of earlier authors. Moss (1993) considered only enteric fermentation in her inventory, 1,420 kt, with no allowance for CH<sub>4</sub> from slurries or manures. Moreover she took only literature values for the production rates of CH<sub>4</sub> by different livestock classes (from Crutzen *et al.*, 1996) rather than making direct measurements.

### **Abatement practices**

Potential abatement practices to reduce N<sub>2</sub>O emissions from housing and storage facilities could involve moves from straw based cattle systems to slurry based systems. The anaerobic nature of slurry stores would reduce N<sub>2</sub>O emission considerably, but possibly, at the expense of increased CH<sub>4</sub> emissions unless preventative actions were taken. A further 'upstream' management strategy would be to reduce N excretion by feeding animals diets more closely related to their nutritional requirements. This hypothesis was proved by Hobbs *et al.* (1996). Spreading the resulting slurry from pigs fed a modified diet onto grassland resulted in significantly lower emissions of NH<sub>3</sub>, CH<sub>4</sub> and denitrification losses and better utilisation of slurry NH<sub>4</sub><sup>+</sup>-N compared with an application of slurry from conventionally fed pigs (Misselbrook *et al.*, 1998). Methane emissions from the rumens of cattle can also be influenced by diet. Recent work at IGER has demonstrated significantly lower CH<sub>4</sub> emissions from beef cattle fed silage maize than the same cattle fed grass silage or hay based diets (unpublished data).

Restrictions on time and rate of application offer the potential for further reducing N<sub>2</sub>O emissions following fertiliser-N and manure applications (Chadwick, 1997). Soil mineral-N levels should be kept at an optimum level for crop requirements and reduced to a minimum at times of low crop demand, e.g. in autumn and early spring when soil conditions are favourable for denitrification.

Reductions in N<sub>2</sub>O emissions from grazed pasture would arise from increasing the productivity per animal with a concurrent decrease in animal numbers, dietary control of N excretion and restricted grazing.

## **5. Conclusions**

Our estimate of N<sub>2</sub>O emission for UK livestock production in 1996 is 21.1kt ± 50%. The largest terms are manure stores (5.65 kt), where 99% of N<sub>2</sub>O emissions arise from solid manure heaps, and soils fertilised with inorganic N fertilisers (5.36 kt). Our estimated emission from fertilised soils may be conservative. Also, more recent data

suggest that losses of N<sub>2</sub>O from grazed pasture, particularly cattle, may have a large influence on the total emission. If we include estimated emission factors for grazed land (Oenema *et al.*, 1997) and the greater fractional loss value for fertilised soils, 1.25%, quoted by Bouwman (1996) we increase the total emission to approximately 45.2 kt a<sup>-1</sup>. Our estimated CH<sub>4</sub> emissions is 845.0 kt, 80% of which is from cattle and 15% from sheep. Over 90 % of all the CH<sub>4</sub> emitted in our inventory is from enteric fermentation.

## 6. Acknowledgements

This work was funded by the UK Ministry of Agriculture, Fisheries and Food (MAFF). IGER and SRI are institutes sponsored by the Biological and Biotechnology Research Council (BBSRC).

## 7. References

**Armstrong Brown S., Rounsevell M.D.A., Annan J.D., Phillips V.R. and Audsley E.** (1996) Agricultural policy impacts on UK nitrous oxide emissions. Proceedings of the EC Workshop on 'Mineral emissions for agriculture', Oslo, Norway, 24-26 January. (Organised by the EU-AIR3 Concerted Action 'Policy measures to control environmental impact from agriculture').

**Blaxter K.L. and Clapperton J.L.** (1965) Prediction of the amount of methane produced by ruminants. *British Journal of Nutrition* 19, 511-522.

**Bouwman A.F.** (1990) *Soils and the Greenhouse Effect*. John Wiley & Sons: Chichester.

**Bouwman A.F.** (1996) Direct emissions of nitrous oxide from agricultural soils. *Nutrient Cycling in Agroecosystems* 46, 53-70.

**Bremner J.M. and Blackmer S.M.** (1978) Nitrous oxide: emission from soils during nitrification of fertiliser nitrogen. *Science* 199, 295-296.

**Burnhill P., Chalmers A. and Fairgrieve J.** (1994) *The British Survey of Fertiliser Practice – Fertiliser use on farm crops, 1993*. HMSO.

**Chadwick D.R.** (1997) Nitrous oxide and ammonia emissions from grassland following applications of slurry: potential abatement practices. In: *Gaseous Nitrogen Emissions from Grasslands* (S. C. Jarvis and B.F. Pain, Eds.) CAB International, Wallingford, UK. pp. 257-264.

**Cicerone R. J.** (1987) Changes in stratospheric ozone. *Science* 237, 35-42.

**Crutzen P.J., Aselmann I. And Seiler W.** (1996) Methane production by domestic animals, wild animals and other herbivorous fauna and humans. *Tellus* 38B, 271-284.

**DANI** (1994). Statistical Review of Northern Ireland Agriculture, 1993. Department of Agriculture for Northern Ireland, Economics and Statistical Division.

**Eichner M.J.** (1990) Nitrous oxide emissions from fertilised soils: summary of available data. *Journal of Environmental Quality* 19, 272-280.

**Firestone M.K. and Davidson E.A.** (1989) Microbiological basis of NO and N<sub>2</sub>O production and consumption in soil. In, *Exchange of Trace Gases between Terrestrial Ecosystems and the Atmosphere* (M.O. Andreae and D.S. Schimel, eds.), pp. 7-21. John Wiley, New York.

**HMSO** (1994) *The Digest of Agricultural Census Statistics, United Kingdom, 1993.* HMSO, London.

**HMSO** (1996) *The Digest of Agricultural Census Statistics, United Kingdom, 1995.* HMSO, London.

**HMSO** (1997) *The Digest of Agricultural Census Statistics, United Kingdom, 1996.* HMSO, London.

**HMSO** (1997b) *Climate change: Second report.*

**IPCC** (Intergovernmental Panel on Climatic Change). (1997) Nitrous oxide and carbon dioxide in agriculture; OECD/IPCC/IEP phase II development of IPCC guidelines for national greenhouse gas inventory methodology. Workshop Report, 4-6 December, 1995, OECD, IPCC, IEA. Geneva (in press).

**Husted S.** (1993) An open chamber technique for determination of methane emission from stored livestock manure. *Atmospheric Environment* 27A, 1635-1642.

**Jarvis S.C. and Pain B.F.** (1994) Greenhouse gas emissions from intensive livestock systems: their estimation and technologies for reduction. *Climatic Change* 30, 1-12.

**Kinsman R., Sauer F.D., Jackson H.A. and Wolynetz M.S.** (1995) Methane and carbon dioxide emissions from dairy cows in full lactation monitored over a six-month period. *Journal of Dairy Science* 78, 2760-2766.

**Kroeze C.** (1995) Comparison of Inventory Methods for Estimating National Emissions of Nitrous Oxide (N<sub>2</sub>O) *Quarterly Journal of the Hungarian Meteorological Service*, 99 (3-4), 209-225.

**Hobbs P.J., Pain B.F., Kay R.M. and Lee P.A. (1996)** Reduction of odorous compounds in fresh pig slurry by dietary control of crude protein. *Journal of Science, Food and Agriculture* 71, 508-514.

**Kirchmann H. (1985)** Losses, Plant Uptake and Utilisation of Manure Nitrogen during a Production Cycle. *Acta Agriculturae Scandinavica* 24, 77 pp.

**Maag M. (1990)** N<sub>2</sub>O production rates and denitrification rates on soil amended with pig slurry. *Mitteilungen der Deutschen Bodenkundlichen Gesellschaft* 60, 205-210.

**Misselbrook T.M., Chadwick D.R., Pain B.F. and Headon D.M. (1998)** Dietary manipulation as a means of decreasing N losses and methane emissions and improving herbage N uptake following application of pig slurry to grassland. *Journal of Agricultural Science* 130, 183-191.

**Mosier A.R. (1989)** Chamber and isotope techniques. In: *Exchange of Trace Gases between Terrestrial Ecosystems and the Atmosphere* (M.O. Andrea and D.S. Schimmel, eds.), Life Sciences Research report 47, John Wiley, Chichester, pp. 175-187.

**Moss A. (1993)** Methane: Global warming and production by animals. Chalcombe Publications, Canterbury, 105 pp.

**Nicholson, R.J. and Brewer, A.J. (1997).** Estimates of Volumes and Exposed Surface Areas of Stored Animal Manures and Slurries in England and Wales. *Journal of Agricultural Engineering Research.*, 66, 239-250.

**Oenema O., Velthof G.L., Yalmulki S. and Jarvis S.C. (1997)** Nitrous oxide emissions from grazed grassland. *Soil use and Management* 13, 288-295.

**Pain B.F., van der Weerden T.J., Chambers B.J., Phillips V.R. and Jarvis S.C. (1998)** A new inventory for ammonia emissions from UK agriculture. *Atmospheric Environment* 32, 309-313.

**Paul J.W., Beauchamp E.G. and Zhang X. (1993)** Nitrous and nitric oxide emissions during nitrification and denitrification from manure-amended soil in the laboratory. *Canadian Journal of Soil Science* 73, 539-553.

**Safely L.M., Casada M.E., Woodbury J.W. and Roos K.F. (1992)** Global methane emissions from livestock and poultry manure. Report to the Global Change Division, U.S. Environmental Protection Agency, Washington, D.C.

**Sibbesen E. and Lind A.M. (1993)** Loss of nitrous oxide from animal manure in dung heaps. *Acta Agriculturae Scandinavica* 43, 16-20.

**Sneath R.W.** (1996) Measuring losses of methane and nitrous oxide from livestock buildings. Paper presented at the Society of Chemical Industry's Symposium 'Methane and nitrous oxide emissions - agriculture's 'contribution', London, 16 January 1996.

**Sneath R.W., Phillips V.R., Demmers T.G.M., Burgess L.R., Short J.L. and Welch S.K.** (1997) Long-term measurements of greenhouse gas emissions from UK livestock buildings. In: 'Livestock Environment V', ASAE Publication 01-97, Vol. 1, pp 146-153.

**Sommer S.G., Sherlock R.R. and Khan R.Z.** (1996) Nitrous oxide and methane emissions from pig slurry amended soils. *Soil Biology and Biochemistry* 28, 1541-1544.

**Velthof G.L. and Oenema O.** (1995) Nitrous oxide fluxes from grassland in the Netherlands: II. Effects of soil type, nitrogen fertiliser application and grazing. *European Journal of Soil Science* 46, 541-549.

**Yalmulki S., Jarvis S.C. and Owen P.** (1998) Nitrous oxide emissions from excreta applied in a simulated grazing pattern. *Soil Biology and Biochemistry* (in press).

# Simulation of the behaviour of sewage sludges in a soil: variation with sludge treatment.

*Modélisation du devenir des boues d'épuration urbaines dans un sol : variation avec le type de boue.*

**S. Houot, G. Delaitre et S. Bourgeois**

INRA, Unité de Science du Sol, BP01, 78850 Thiverval Grignon

E-mail : houot@jouy.inra.fr

## Abstract

*A simulation model describing the dynamics of organic matter in soil has been used to compare the behaviour of different sewage sludges (SS) issued from the same waste waters in a soil. Three sewage sludges were used coming from the treatment of the waste waters of Plaisir (Yvelynes, France): a liquid SS, a dehydrated SS and a limed SS. Their mineralization and the evolution of N availability were followed during their incubation in a loamy soil under controlled laboratory conditions. The experimental results were used to calculate the degradation rate of the organic fraction of the SS with the simulation model NCSOIL. The model NCSOIL describes the organic matter dynamics in a soil. Three organic compartments are considered: the microbial biomass, a fraction of labile organic matter and an exogenous organic matter (the sludge in our case). The degradation rates of the SS organic fraction were estimated with NCSOIL. The degradation of the liquid SS was more rapid ( $37 \cdot 10^{-2} \text{ d}^{-1}$ ) than the degradation of the two solid SS ( $0.7 \cdot 10^{-2}$  and  $1.6 \cdot 10^{-2} \text{ d}^{-1}$  for the dehydrated and the limed SS, respectively). The efficiency of SS incorporation into the microbial biomass was larger for the liquid SS (60%) than for the two solid SS (30%).*

Key-words : Sewage Sludges, soil, simulation, nitrogen, microbial biomass.

## Résumé

Les objectifs de ce travail sont d'utiliser un modèle décrivant la dynamique de la matière organique du sol pour comparer l'évolution de différentes boues d'épuration urbaines provenant des mêmes eaux usées dans un sol.

Les 3 boues proviennent de l'épuration des mêmes eaux usées de la ville de Plaisir (boue liquide digérée anaérobie, boue déshydratée et boue déshydratée chaulée). Leur minéralisation et la disponibilité de leur N sont étudiées expérimentalement au laboratoire au cours d'incubations de sol (sol limono-argileux) additionné des boues. A partir de ces résultats expérimentaux, on calcule à l'aide du modèle NCSOIL, le coefficient de dégradation de la fraction organique de ces boues.

NCSOIL est un modèle décrivant la dynamique de la matière organique dans un sol. Les 3 principaux compartiments de matière organique considérés dans NCSOIL sont : la biomasse microbienne du sol, un compartiment de matière organique labile et un compartiment de matière organique exogène au sol, la fraction organique de la boue dans ce cas. L'azote potentiellement minéralisable du sol provient de la minéralisation des 2 compartiments organiques du sol. La dégradation de la fraction organique de la boue conduit à la formation de biomasse microbienne, puis à son incorporation dans la matière organique labile du sol.

Le modèle NCSOIL permet d'estimer la vitesse de dégradation de la fraction organique des différentes boues. Celle-ci est beaucoup plus rapide pour la boue liquide ( $37 \cdot 10^{-2} \text{ j}^{-1}$ ) que pour les 2 boues déshydratées ( $0.9 \cdot 10^{-2}$  et  $1.8 \cdot 10^{-2} \text{ j}^{-1}$  pour la boue déshydratée et chaulée respectivement). Le chaulage semble avoir un effet positif sur la vitesse de dégradation de la matière organique de la boue. Enfin, le rendement d'incorporation dans la biomasse microbienne est supérieur pour la boue liquide (60%) par rapport aux boues déshydratées (30%).

Mots-clés : boue d'épuration urbaine, modélisation, azote, biomasse microbienne.

## 1. Introduction

Sewage sludge application on cultivated soils represents an alternative to their incineration or landfilling and has been frequently used to recycle nutrients such as nitrogen through crop production. The rates of sludge application on soils have to be adjusted to the crop needs to avoid production of excess  $\text{NO}_3^-$  which could leachate towards the ground waters. Heavy metal and organic pollutant accumulation after repeated sludge application has also received a lot of attention recently. The availability of sludge N varies with the sludge characteristics resulting from the process of waste water treatment (Wiar *et al.*, 1996). The soil and the climatic conditions also influence sludge evolution after their application on soils (Bourgeois *et al.*, 1996). Laboratory incubations have been often used to estimate the N available in soils or organic amendments. The mineralization kinetics are adjusted to first order kinetics and  $\text{N}_0$ , potentially mineralizable N determined.

Simulation allows to better understand N fluxes in soils which are not available through measurement or calculation (Bjarnason, 1988) and to consider them simultaneously. Numerous models have been elaborated to describe C and N dynamics in soils. They can be used for better understanding the behaviour of organic amendments in soils (Hsieh *et al.*, 1981a; 1981b; Hoffmann and Ritchie, 1993; Houot *et al.*, 1995).

In the present work, the NCSOIL model describing the dynamics of organic matter in soil (Molina and Smith, 1998) was used to compare the behaviour of three different sewage sludges issued from the same waste waters in a soil.

## 2. Materials and methods

### Soil and sludges

The soil was sampled in the upper 30 cm of a liquid sludge treated plot in a long term field experiment located in Grignon (Yvelines, France). This field experiment has been initiated in 1986 to determine the N availability of a liquid sewage sludge for cultivated crops (wheat-maize rotation until 1993 and continuous maize since 1993) as compared to classical mineral fertilizer (Michelin, 1996). The soil was passed through a 5 mm sieve immediately after sampling in March 1996 before sludge application, then kept moist at 4°C until use. The loamy soil was classified as Typic Eutrochrept (Soil Taxonomy) and had the following analytical characteristics (in g kg<sup>-1</sup> of soil): clay, 220; silt, 730; sand, 50; organic C, 13.4; total N, 1.3. The soil pH (in water) was 7.3.

Three sewage sludges were used, all coming from the same waste water treatment plant located in Plaisir (Yvelines, France): a liquid sewage sludge anaerobically digested (liquid SS), the same sludge after dehydration by filtration press (dehydrated SS) and the dehydrated sludge after lime addition (limed SS). Their main analytical characteristics are presented in the table 1.

	Liquid SS	Dehydrated SS	Limed SS
Dry Matter (% fresh material)	1.7	21.7	26.6
Organic Matter (% DM)	63.8	63.0	50.6
Organic Carbon (% DM)	35.7	36.9	30.4
Total N (% DM)	9.1	5.4	3.5
N -NH <sub>4</sub> <sup>+</sup> (% DM)	5.1	1.2	0.4
Organic N (% DM)	4.0	4.2	3.1
C/N total	3.9	6.8	8.6
C/N organic	9.0	8.8	9.6

Table 1.

*Analytical characteristics of the sewage sludges coming from the waste water treatment plant of Plaisir (Yvelines, France).*

### Incubations

Incubations were realized in triplicate with 50g of fresh soil corresponding to 42g of dry soil in 500 ml jars hermetically stoppered in controlled conditions (28°C, humidity equivalent to 85% of field capacity, in the dark) during 63 days. In the treatments with sludges, 2g of fresh dehydrated or limed SS was added to the soil, approximately doubling the rate of application in field conditions. In the liquid SS treatment, the soil was previously air dried before incubation in order to be able to add 2.3 g of liquid SS without running the incubations under waterlogged conditions.



The C-CO<sub>2</sub> evolved during the incubation resulting from the mineralization of soil and sludge organic matter was trapped in 10 ml of NaOH 0.5M replaced after 3, 7, 10, 14, 21, 28, 42 and 63 days of incubation and analyzed by colorimetry on a continuous flow analyzer (Skalar, Breda, the Netherlands) using the method described by Chaussod *et al.* (1986). Mineral N was extracted after 0, 7, 14, 28, 42 and 63 days of incubation in 200 ml of K<sub>2</sub>SO<sub>4</sub> 0.025M. The extracts were recovered after decantation and filtration and mineral N was analyzed by colorimetry using the indophenol blue method for NH<sub>4</sub><sup>+</sup> and the Griess-Ilosvay method for NO<sub>3</sub><sup>-</sup>.

The microbial biomass was measured in the initial soil then after 7, 28 and 63 days of incubation in the different treatments, using the fumigation-extraction method (Vance *et al.*, 1987; Wu *et al.*, 1990).

### NCSOIL model

The simulation model NCSOIL-MIT was used to analyze the data. The model has been described previously (Hadas *et al.*, 1987; Houot *et al.*, 1989; Barak *et al.*, 1990; Molina *et al.*, 1990). In this model, two soil organic matter pools and one exogenous organic matter pool (EOM) are considered (Figure 1). The two organic pools correspond to the microbial biomass and the labile organic matter, respectively. The labile organic matter pool is a fraction of the humified organic matter which remains easily mineralizable and from which most of the soil potentially mineralizable nitrogen comes from. All the organic pools decay with first order kinetics (Table 2). The N fluxes are driven by the decomposition of the organic pools and only mineral N can be incorporated into the microbial biomass.

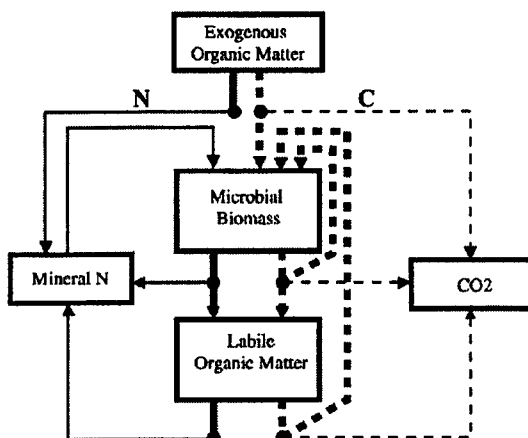

Figure 1.

Structure of NCSOIL-MIT model for the C (dotted lines) and N flows (continuous lines).

Organic and mineral flows are distinguished by thick and thin lines, respectively.

At each timestep (one day), part of the degraded sewage sludge is incorporated into the microbial biomass simulating the use of the exogenous C source for microbial growth (EFFAC, Table 2), the complement of the degraded fraction being mineralized as CO<sub>2</sub>. Similarly, part of the degraded microbial biomass is incorporated into the labile organic matter, simulating the humification process (EFSINK), part is recycled into the microbial biomass (EFFAC) and the complement is mineralized. The degraded labile organic matter is also partly incorporated into the microbial biomass (EFFAC) and partly mineralized.

The experimental kinetics of C and N mineralization during the control treatment (soil alone) were used to estimate the size of the labile organic matter in the soil with the model. Then the experimental kinetics of C and N mineralization during the incubation of soil treated with the different sludges were used to estimate the constant rate of sludge degradation. The optimum values for the parameters were searched by the Marquardt algorithm modified to accept data from simulation models (Barak *et al.*, 1990). The optimization was directed by the following figure-of-merit function :

$$X^2 = \sum_j S_j S_m \{ (Y_{jm} - Y_j(m,A)) / SD_j \}^2$$

where  $j = 1, \dots$  is the state variable index,  $m = 1, 2, \dots$  is the sampling's index (6 sampling days),  $Y_{jm}$  are the measured values,  $Y_j(m,A)$  are the simulated values for the set of model's constants A, and  $SD_j$  is the standart deviation of the experimental data. Low  $X^2$  values indicated a good fit between experimental and simulated data. Various optimization process were conducted for different values of sludge EFFAC (sludge degraded fraction incorporated into the microbial biomass). The results presented correspond to the combination of constant rate of sludge degradation and EFFAC parameter leading to the lowest  $X^2$  values.

	Microbial Biomass	Labile Organic Matter	Sludge
Initial level (mg C kg <sup>-1</sup> dry soil)	180	Optimized	total added C
organic C/ organic N	6	11	of Table 1
Constant rate of degradation (day <sup>-1</sup> )	0.332 or 0.040*	0.03	Optimized
EFSINK (fraction of the degraded biomass incorporated into the labile organic matter)	0.2	**	**
EFFAC (fraction of the degraded organic compartment incorporated into the microbial biomass)	0.6	0.4	Optimized

\* the microbial biomass is divided into 56% of labile fraction (constant rate of degradation = 0.332) and 44% of resistant fraction (constant rate of degradation = 0.040)

\*\* does not apply

Table 2.

*NC SOIL parameters describing the evolution of the organic pools. Three parameters were optimized against experimental data: the initial level of the labile organic matter, the constant rate of degradation of the sludges and the fraction of degraded sludge incorporated into the microbial biomass (EFFAC).*

### 3. Results and Discussion

#### Sludge evolution during the incubations

The experimental kinetics of C-CO<sub>2</sub> and mineral N evolution during the incubation of soil alone and soil added of the different sludges are presented in Figure 2. The mineralization of sludge organic C was estimated by subtracting the C-CO<sub>2</sub> evolved during the incubation of soil alone from the C-CO<sub>2</sub> evolved during the incubation of sludge treated soil. At the end of the incubations, 48% of the liquid SS carbon was mineralized and 34% of the dehydrated and limed SS carbon. The organic C of the liquid SS was more easily mineralized than the organic C of the dehydrated and limed SS. Dehydration decreased the biodegradability of sludge organic C but the addition of lime did not seem to affect it.

All the sludge contained NH<sub>4</sub><sup>+</sup> which was rapidly nitrified during the first days of incubation (Fig. 2). The evolution of N-NO<sub>3</sub><sup>-</sup> coming from the sludge was estimated as for C mineralization by subtracting the N-NO<sub>3</sub><sup>-</sup> issued from the soil organic matter mineralization during the control incubations to the evolution of N-NO<sub>3</sub><sup>-</sup> during the incubation of sludge treated soils. The results were then described with first order kinetics  $N = N_0 * (1 - \exp(-k*t))$  where N is the N-NO<sub>3</sub> issued from the sludge expressed in mg per kg of sludge dry matter, N<sub>0</sub> the sludge potentially mineralizable N and k the constant rate of N-NO<sub>3</sub> formation including NH<sub>4</sub> nitrification and organic N mineralization (Table 3).

From their analytical characteristics, the three sludges were susceptible to produce mineral N, since they are characterized by high N contents and low C to N ratio (Chaussod *et al.*, 1986). At the end of the incubations, most of the liquid SS nitrogen was present as NO<sub>3</sub> and 93.8% of the sludge N was potentially mineralizable. This proportion was larger than the 70% previously encountered in a study with similar sludge (Houot *et al.*, 1996). As a matter of fact, 56% of the sludge N was already present as NH<sub>4</sub> and would be immediately available for plants in field conditions if no lost by volatilization occurred. With the hypothesis that 100% of N-NH<sub>4</sub> was included in N<sub>0</sub>, the fraction of sludge organic N easily mineralizable in the liquid SS represented 85% of the organic N which was larger than the 27% proposed by Hutchings (1984).

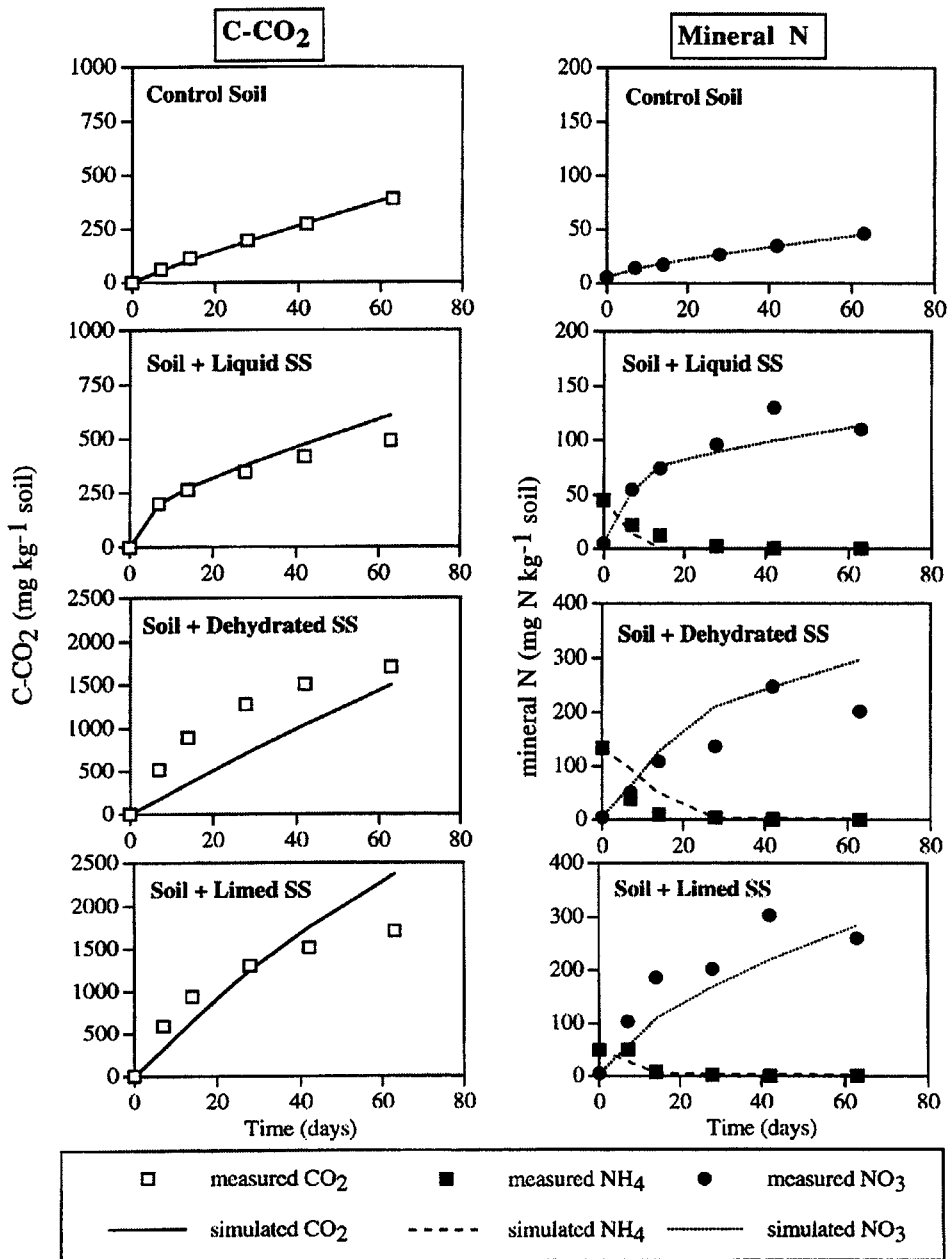

**Figure 2**  
 Experimental and simulated kinetics of C mineralization and of mineral N evolution during the incubation of the soil alone or added of the different sludges.

Sludges	$N_0$		k (day <sup>-1</sup> )	$r^2$
	(g N kg <sup>-1</sup> dry matter)	(% total sludge N)		
Liquid SS	85.2	93.8	0.101	0.89
Dehydrated SS	18.1	33.2	0.043	0.87
Limed SS	17.9	51.0	0.076	0.92

Table 3.

Parameters of the first order kinetics used to describe N-NO<sub>3</sub> evolution from the different sludges:  $N=N_0 * (1-\exp(-k*t))$  where N is the N-NO<sub>3</sub> issued from the sludge.

Dehydration decreased the N content of the sludge, mainly because of the lost of N-NH<sub>4</sub> in the liquid phase (Table 1). This was partly responsible for the decrease of the percentage of easily mineralizable N in the sludge which represented 33% of total N, proportion previously reported by Furrer and Bolliger (1978). On the other hand, only 14% of the sludge organic N was easily mineralizable (estimated as previously) and dehydration seemed to modify the sludge organic matter as compared to the liquid SS, confirming the results of C mineralization.

Contradictory results have been observed about N availability in sewage sludge after lime addition, with examples of enhancement or decrease of the N availability (Bourgeois *et al.*, 1996). Lime addition to the dehydrated sludge resulted in volatilization of the remaining NH<sub>4</sub> and diluted the organic N content which decreased. However, contrary to the identical C mineralization in the limed and dehydrated sludge, the potentially available N increased in the limed SS as compared to the dehydrated SS and 51% of the organic N was potentially mineralizable. The N mineralization was faster in the limed SS than in the dehydrated SS as shown by the larger constant rate of mineralization k (Table 3). This larger apparent availability of organic N in the limed SS could be related to the microbial immobilization of N observed at the beginning of the incubation with the dehydrated SS but not with the limed SS (results not shown).

#### Simulation of the behaviour of the sewage sludges in the soil

The simulated kinetics of C and N mineralization are compared to the experimental results in the Figure 2. The initial level of the labile soil organic matter was optimized against the results of C and N mineralization during the control incubations, represented 25% of the total soil organic C and resulted in a good simulation of the experimental results as revealed by the low X<sup>2</sup> value of 1.9 10<sup>-3</sup>. In comparison, the simulations of C and N mineralization in the sludge treated soils were not as good as revealed by the larger X<sup>2</sup> values (Table 4). However, simulation with the NCSSOIL model allowed to consider both the sludge C and N evolution and to distinguish the behaviour of mineral and organic N from the sludge. The organic matter was more easily degradable in Liquid SS than in the two other sludges as shown by its larger constant rate of degradation and larger incorporation into the microbial biomass.

Sludges	Constant rate of degradation (day <sup>-1</sup> )	EFFAC	X <sup>2</sup>
Liquid SS	37 10 <sup>-2</sup>	0.60	0.11
Dehydrated SS	0.7 10 <sup>-2</sup>	0.30	0.35
Limed SS	1.6 10 <sup>-2</sup>	0.30	0.23

Table 4.

Optimization with NCSSOIL of the constant rate of degradation of the organic fraction of the different sludges and of the fraction of decomposed sludge incorporated into the microbial biomass (EFFAC).

The lowest the X<sup>2</sup> values are, the best is the simulation.

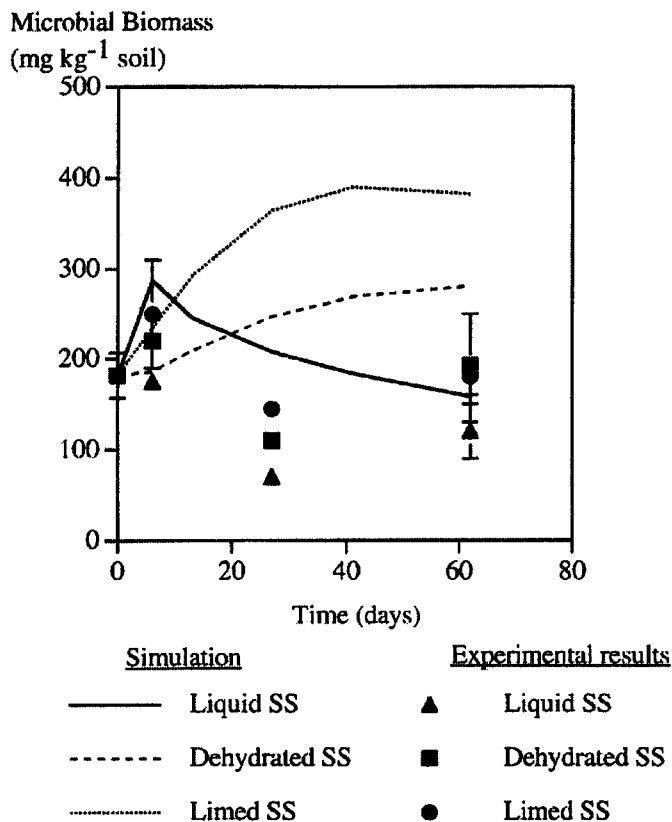

Figure 3

Evolution of the microbial biomass during the incubation of sludge treated soil : simulated and experimental results.

## 4. Conclusion

The potentially mineralizable N of liquid SS was larger than this of dehydrated or limed SS. In field condition, most of the liquid SS would be available for plants during the year after sludge application when only 30 to 50% of the dehydrated or limed SS nitrogen was easily mineralizable. For these two sludges, the mineralization of the organic N should be taken into account during the years following sludge application. Lime addition seemed to increase the sludge N availability. The NCSOIL model confirms the very fast degradation of the liquid sludge organic fraction and the larger degradability of the limed SS than of the dehydrated SS. The experimental kinetics of C and N mineralization observed during the incubation of sludge treated soil were rather well simulated. Nevertheless, the discrepancies observed between the experimental and the simulated results of microbial biomass evolution showed that the model could be ameliorated. Even if some experimental results are well simulated, simulation results should always be considered with carefulness and not accepted without large validation work.

## 5. Acknowledgements

This work was financially supported by ADEME (Agence de l'Environnement et de la Maitrise de l'Energie).

## 6. References

- Barak P., Molina J. A. E., Hadas A. and Clapp C. E.** (1990). Optimization of an ecological model with the Marquardt algorithm. *Ecol. model.* 51, 251-263.
- Bjarnason S.** (1988) Calculation of gross nitrogen immobilization and mineralization in soil. *J. Soil Sci.*, 39, 393-406.
- Bjarnason** (1988). Calculation of gross nitrogen immobilization and mineralization in soil. *J. Soil Sci.*, 39, 393-406.
- Bourgeois S., Michelin J., Fumery H. and Wiart J.** (1996) La valeur azotée des boues résiduelles des stations d'épuration urbaines. ADEME, Angers, 336p.
- Chaussod R., Germon J. C., and Catroux G.** (1981) Essai de détermination au laboratoire de l'aptitude à la minéralisation d'azote des boues résiduelles urbaines. Académie d'Agriculture, 13 Mai 1981, 762-771.
- Chaussod R., Nicolardot B. and Catroux G.** (1986) Mesure en routine de la biomasse microbienne des sols par la méthode de fumigation au chloroforme. *Science du Sol*, 2, 201-211.

**Furrer O. J. and Bolliger R.** (1978) Wirksamkeit des Stickstoffs von verschiedenen Klarschlammen im vergleich zu Ammonitrat. Symposium européen sur la caractérisation et l'utilisation des boues résiduelles. Cadarache, 13-15 Février 1979, pp 247-252.

**Hadas A., Molina J. A. E., Feigenbaum S. and Clapp C. E.** (1987) Simulation of 15N by the model NCSOIL. Soil Sci. SOC. AM. J., 51, 102-106.

**Hoffmann F. and Ritchie J. T.** (1993) Model for slurry and manure in CERES and similar models. J. Agronomy & Crop Science, 170, 330-340.

**Houot S. Cadot L and Molina J.A. E.** (1995) Simulation with the model NCSOIL of the temperature and humidity impact on sewage sludge nitrogen evolution in soils. In "Modelling the fate of agrochemicals and fertilizers in the environment" C. Giupponi, A. Marani and F. Morari Editors, European Society for Agronomy, Unipress, pp 273-293.

**Houot S., Cadot L. and Gnanalingam V.** (1996) Variations with pedoclimatic conditions of an anaerobically digested liquid sewage sludge C mineralization and its N-NO<sub>3</sub> availability. In "Modern Agriculture and the Environment" D. Rosen, E. Tel-Or, Y. Hadar and Y. Chen Editors, Kluwer Academic Publishers, pp 401-411.

**Houot S., Molina J. A. E., Chaussod R. and Clapp C. E.** (1989). Simulation by NCSOIL of net mineralization in soils from the Dehérain and 36 parcelles fields at Grignon. Soil Sci. Soc. Am. J., 51, 102-106.

**Hsieh Y. P., Douglas L. A. and Motto H. L.** (1981a) Modelling sewage sludge decomposition in soil : I Organic carbon transformation. J. Environ. Qual., 10, 54-59.

**Hsieh Y. P., Douglas L. A. and Motto H. L.** (1981b) Modelling sewage sludge decomposition in soil : II Nitrogen transformation. J. Environ. Qual., 10, 59-64.

**Hutchings N. J.** (1984) The availability of nitrogen in liquid sewage sludges applied to grassland. J. Agric. Sci. Camb., 102, 703-709.

**Michelin J.** (1996) Synthèse de huit années d'expérimentation sur la valorisation agricole de boues liquides (essai Grignon/ boues anaérobies de la ville de Plaisir - 78). In " Valeur fertilisante des boues d'épuration ". ADEME, Paris, pp 61-68.

**Molina J. A. E. Hadas A. and Clapp C. E.** (1990) Computer simulation of nitrogen turnover in soil and priming effect. Soil Biol. Biochem., 22, 349-353.



**Molina J. A. E. and Smith P.** (1998) Modeling carbon and nitrogen processes in soils. *Advances in Agronomy*, 62, 253-298.

**Vance E. D., Brookes P. C. and Jenkinson D. S.** (1987) An extraction method for measuring microbial biomass C. *Soil Biol. Biochem.*, 19, 703-707.

**Wiat J., Six P. and Van Laethem C.** (1996) Origine, typologie et composition des boues d'épuration urbaines. In "Valeur fertilisante des boues d'épuration". ADEME, Paris, pp 15-22.

**Wu J., Joergensen R. G., Pommrening B., Chaussod R. and Brookes P. C.** (1990) Measurement of soil microbial biomass C by fumigation-extraction, an automated procedure. *Soil Biol. Biochem.*, 22, 1167-1169.

## **Proposal of an integrated approach to characterize « the nitrogen value » of organic products spread in agriculture.**

*Approches expérimentales utilisables pour caractériser la valeur azotée  
des produits organiques épandus en agriculture.*

**Nicolardot B, Parnaudeau V.**  
INRA, Unité d'agronomie,  
2 esplanade R. Garros, BP 224,  
51686 Reims cedex, France  
E-mail : nicolard@reims.inra.fr

**Machet J.M.**  
INRA, Unité d'agronomie,  
Rue Fernand Christ,  
02007 Laon cedex, France

**Marcovecchio F.**  
Station Agronomique de l'Aisne,  
Rue Fernand Christ,  
02007 Laon cedex, France

### **Abstract**

*An integrated approach is proposed to study the behaviour of organic products in soil and their N availability. In field, N dynamics of organic products is studied using periodic inorganic N determinations in the soil profiles of plots maintained bare during the experiments. Net mineralization of organic products is then estimated by taking into account net mineralization in soil with and without organic residues and using a model which calculates N leaching and mineralization. In laboratory, N mineralization kinetics are measured during soil incubations under controlled conditions. Comparison with field data is rendered possible by using a normalized time scale which takes into account the effect of soil moisture and temperature on soil biological processes. Finally, organic products are characterized using chemical or biochemical determinations (e.g. water solubility at different temperatures). This methods would allow to differentiate products from different origins, first results being correlated to incubation data. Final objectives are to provide data which will be used to parameterize soil C and N transformations models and decision making tools and propose some chemical or biochemical tests which rapidly characterize the various organic products used in agriculture.*

### **Résumé**

Différentes approches ont été utilisées pour caractériser le devenir de résidus organiques dans le sol et déterminer leur valeur azotée. Etant donné la diversité des produits organiques utilisés en agriculture, il est nécessaire de proposer des tests de laboratoire qui permettent de rendre compte du comportement des

produits dans le sol et de leur valeur agronomique, en s'affranchissant de la mise en place de longues ou lourdes expérimentations au champ ou au laboratoire.

Au champ, la dynamique de l'azote après apport de produits organiques a été suivie au moyen de mesures fréquentes d'azote minéral effectuées sur le profil de sols maintenus nus pendant l'expérimentation. La minéralisation nette de l'azote organique des résidus est ensuite estimée avec un modèle de calcul du lessivage et de la minéralisation LIXIM et en prenant en compte les résultats obtenus pour un sol témoin sans épandage.

Au laboratoire la cinétique de minéralisation potentielle du carbone et de l'azote des produits a été mesurée au cours d'incubations de sol en conditions contrôlées. Les résultats sont bien corrélés aux données de minéralisation nette mesurées sur le terrain, la comparaison ayant été rendue possible grâce à l'utilisation d'une échelle de temps exprimée en « jours normalisés » qui prend en compte les lois d'action de la température et de l'humidité sur les processus biologiques.

Les produits ont été également caractérisés au moyen d'analyses chimiques ou biochimiques (par exemple solubilité à l'eau à différentes températures). Cette approche permettrait de relativement bien différencier des produits d'origines variées, les premiers résultats étant bien corrélés aux données acquises en incubation.

Toutes ces méthodes sont enfin discutées en considérant la typologie et la nature des produits pris en compte.

**Mots-clés** : produits organiques, décomposition, minéralisation nette, tests de laboratoire.

## 1. Introduction

The diversity of organic products spread on agricultural areas is very important. These organic products include effluents from cattle breeding (manure, slurries,...), sewage sludge and waste waters from agro-industries (starch potato factory, sugar refinery, cannery, distillery, dairy, paper mill,...). Urban wastes (sewage sludge, refuse composts, vegetable wastes...) are also spread on agricultural fields. In addition, some of these organic products can be mixed together or co-composted. Agronomical value of these organic products consists in bringing to soil organic matter or nutrients (essentially N, P, K...).

Nevertheless, this agronomical value is generally imprecise or not well known due to the lack of knowledge on the behaviour of these organic products in soil and on the dynamics of nutrients (N, P...) after spreading. This is reinforced by the considerable number of different organic products used in agriculture. For organic

products coming from agro-industry, this diversity is mainly related to the origin and nature of agricultural products, and the numerous processes of transformation of agricultural products. For a given organic product, characteristics may change equally with time (e.g. starch factories which process different potatoes varieties along the season). In addition, some other factors may influence this variability as for example the physical, chemical and biological treatments applied to effluents or wastes and the conditions of storage.

Thus, there is a need to establish a classification or a typology based on different criteria as, for example, origin, nature, type or physical appearance of products in order to better predict the behaviour and N dynamics of organic products incorporated in soils. Those criteria require the implementation of analytical tests or methods of characterization, which must be simple, rapid and of a low cost. Main objective of our work is to propose an integrated approach to characterize the N value of organic products and afterwards simple methods to predict their behaviour under field conditions.

## **2. Existing methods to measure N availability of organic products**

Different experimental approaches have been proposed to assess N availability of agricultural soils and organic products used in agriculture as organic amendments or fertilizers. These methods include field trials, greenhouse experiments, laboratory incubation and chemical extraction (Bundy and Meisinger, 1994; Bourgeois *et al.*, 1996; Chaussod *et al.*, 1997).

Field trials provide N values measured in real conditions considering various pedoclimatic conditions and different cultures. N values are usually evaluated using two experimental methods: i) calculation of the apparent utilization coefficient (AUC), which corresponds to the ratio between N of organic products recovered in plants (N recovered in plants growing on soil + organic products minus N recovered in plants growing on control soil without organic products) expressed in % of N from organic products; ii) use of N response curves where N of organic products recovered in plants for a defined rate is compared to plant N obtained for different increasing N fertilizer rates. N values are equally evaluated during the cultivation of plants grown in controlled growth chambers or glasshouses (Bould, 1948; Chaussod *et al.*, 1981) using comparable methods.

N values can be assessed using laboratory soil incubations where the evolution of C and/or N of organic products mixed with soil are measured during more or less long periods under optimal soil moisture and temperature (Premi and Cornfield, 1971; Chèneby and Nicolardot, 1992). Soil incubations provide information both on N mineralization kinetics and N quantities which are released during the decomposition of organic products. N mineralization kinetics are then interpreted to

define N availability using simple mathematical equations (Yadvinder *et al.*, 1988; Chèneby *et al.*, 1994) derived from those proposed by Stanford and Smith (1972) to assess N mineralization potential of soils. N released during soil incubations appears well correlated with crop N uptake in pot studies, but relationships are poor when considering field studies (Jarvis *et al.*, 1996).

Numerous chemical indexes have been proposed to estimate soil organic N availability (Stanford, 1982). These methods determine amounts of N rendered soluble by chemical extracting agents which simulate mineralization activity of the soil microflora: they include more or less concentrated acid or alkaline reagents associated or not with oxidizing agents, extraction being performed at more or less high temperature. Some of these methods have been used to differentiate and characterize N availability of different organic products (Chaussod *et al.*, 1981; Castellanos and Pratt, 1981; Douglas and Magdoff, 1991). All these chemical indexes have not been tested on a broad range of organic products and field conditions (Jarvis *et al.*, 1996), thus they can be used with difficulty for the moment in decision making tools to predict N released by organic products (Chaussod *et al.*, 1997).

### **3. Proposal of an integrated approach to measure N availability**

The three approaches described above have almost never be used simultaneously on a broad range of conditions. Elsewhere coefficients or rules to link results obtained with these approaches have not been systematically determined. The integrated approach proposed to characterize the N value of residues is described in Fig. 1. During a first step the objective will consist to establish relationships between the 3 approaches for a wide range of organic products and field conditions. Characterization and incubation can be easily performed on numerous products whereas field experiments using selected organic products will allow us to validate results obtained with laboratory methods. During a second step, results of chemical or biochemical tests will be used in models or making decision tools to predict behaviour of organic products in soil.

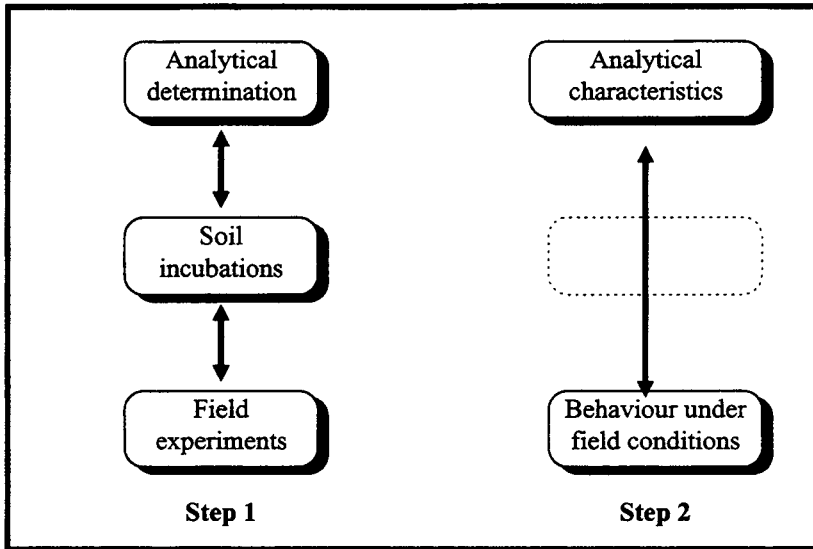

*Figure 1*  
 Proposed approach to predict the behaviour  
 of organic products in field conditions.

### **Residual inorganic N in soil**

Fig. 2 shows the approach used in field experiments to evaluate net N mineralization from potatoes starch industry waste water (Justes *et al.*, 1998). Two treatments were compared: bare soil with or without (control soil) waste water. Spreading amounts were about  $500 \text{ m}^3 \text{ ha}^{-1}$ . Soil inorganic N and moisture were measured in the soil profile (0-120 cm, 4 layers) every 2 or 4 weeks during a 9-month period. Net N mineralization in the different treatments was calculated using a simple N mineralization and leaching model LIXIM (Mary, 1996). This model takes into account water and nitrate movements and N mineralization in bare soils. The description of nitrate movement is based on Burn's algorithm (1976), but takes also into account the daily rainfall and soil evaporation, the actual initial nitrate N profile, the atmospheric inputs and N mineralization. Then cumulated net mineralization and nitrification coming from waste water was calculated by difference with the control soil (Fig. 2).

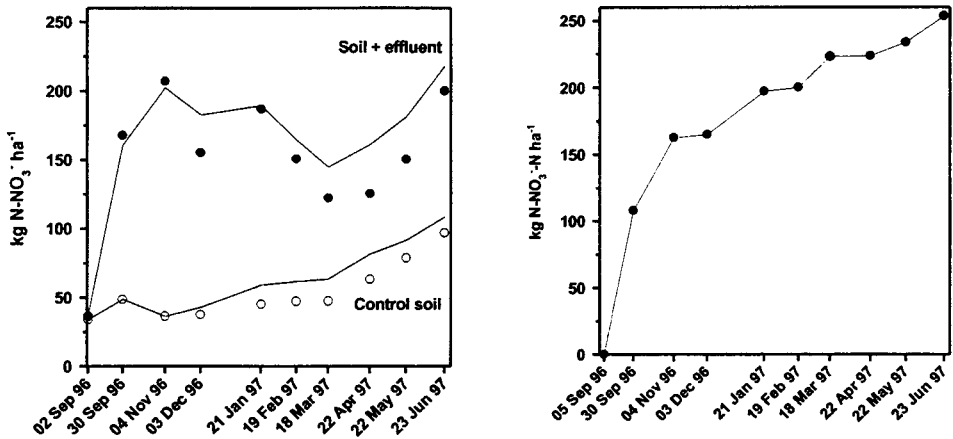

Figure 2

*N* mineralization of potatoes starch factory waste water under field conditions. Left: measured (symbols) and simulated (lines) data of nitrates amounts in the soil profile. Right: cumulative nitrification and mineralization from waste water N (from Justes et al., 1998).

This approach which determines N mineralization of organic products in field conditions, gives information both on amounts and kinetics comparing to N balance or cropping data. Nevertheless, this method considers only bare soil, results being largely influenced by agricultural practices and soil or climatic conditions. In addition, field measurements are time-consuming and expensive.

### Soil laboratory incubation

Fig. 3 presents C and N mineralization kinetics obtained during a soil incubation in presence of different organic products whose main characteristics are summarized in Table 1.

The organic products (applied at a rate corresponding to 100 mg N kg<sup>-1</sup> dry soil) were incorporated to a sieved loamy soil (clay = 17 %, loam = 77 %) and incubated in controlled conditions (20° C, soil moisture = 20 % near field capacity). Carbon dioxide emissions and soil inorganic N were monitored as described by Recous et al. (1995) in soils with or without addition (control soil) of organic products. Then cumulated net mineralization of C and N coming from organic product was calculated by difference with the control soil. This incubation method allows to discriminate different organic products in terms of N availability according to their characteristics (Fig. 3).

	Dry Matter (%)	C (%)	N (%)	C/N ratio
Compost from different agro-industrial co-products	31.6	11.3	1.5	7.5
Concentrated vinasse	57.1	18.4	3.3	5.6
Dried agro-industrial sludge	94.7	31.1	6.3	5.0
Sludge of paper mill	57.5	13.3	0.7	19.0

Table 1  
Main characteristics of organic products studied during soil incubations.

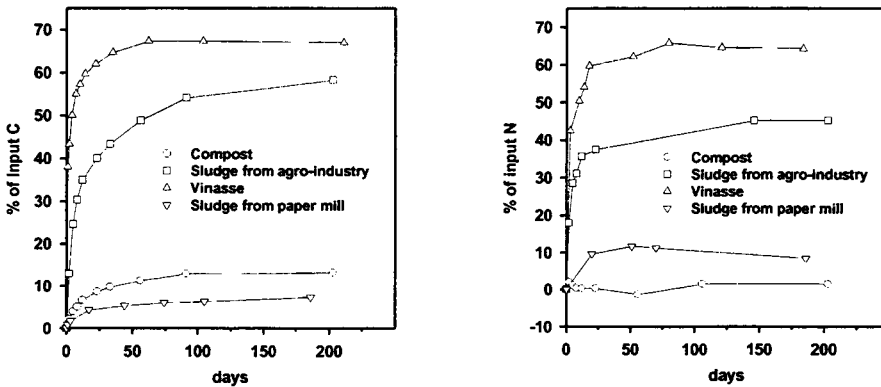

Figure 3  
C mineralization (left) and N mineralization (right) of different organic products studied during a soil incubation under controlled conditions.

Incubation methods provide information on both C and N kinetics and potential mineralization. In addition, precise estimations of C and N fluxes involved during decomposition are obtained when isotopic tracers ( $^{15}\text{N}$ ,  $^{13}\text{C}$  or  $^{14}\text{C}$ ) are used. Comparing to field experiments, they allow the study of numerous organic products in a short period of time. On the other hand, data are obtained in artificial conditions (optimal temperature and soil moisture), incubated organic products being probably different from those studied in field (organic products dried and crushed for incubation methods). Nevertheless relationships between field and incubation data are relatively well established as it is shown on Fig. 4. Results obtained for potatoes starch factory waste water (see above §) in field (temperature and soil moisture variable) or during soil incubation ( $28^\circ\text{C}$ , soil moisture at field capacity) were compared using functions describing the effects of temperature and soil moisture on soil N mineralization (Recous, 1994; Rodrigo *et al.*, 1997). Considering these effects, it is then possible to calculate climatic factors and convert days with variable soil moisture and temperature to days (normalized days) with reference soil moisture and temperature. Finally, "normalized days" allow the comparison and validation of incubation results with data obtained under field conditions.



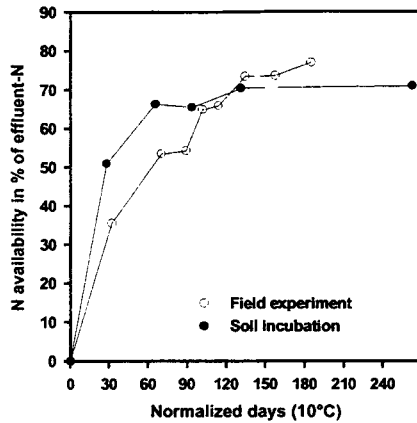

Figure 4

Comparison of N released from potatoes starch factory waste water measured under field conditions and during soil incubations using a normalized time scale at 10°C (from Justes et al., 1998).

### Chemical indexes

One available approach to characterize organic products consists to differentiate fractions using an adaptation of solubility methods as the ones used to characterize the fertilizers of organic synthesis (Afnor, 1988). Water extraction at different temperatures (20°C and 100°C) allows to obtain fractions in which nitrogen is analyzed by the Kjeldahl method: N fraction soluble N at 20°C, N fraction insoluble at 20°C and soluble at 100°C, and N fraction insoluble at 100°C.

The separation of the different fractions was performed on organic products which were partially dried and crushed at 200 µm. Table 2 shows results obtained with some of these organic products. In that case, there is a close relationship between the N fraction which is soluble at 20°C or the N fraction insoluble at 100°C and N mineralized during a 180 day period soil incubation (see above §). Nevertheless, this relationship must be validated on a wide range of organic products. Moreover a similar approach should be used to separate different C fractions.

	Soluble N at 20°C	Insoluble N at 100°C	Mineralized N during incubation
Compost from agro-industrial co-products	11	84	2
Concentrated vinasse	94	5	64
Dried agro-industrial sludge	34	55	45
Sludge of paper mill	6	82	8

Table 2

N fractions obtained by water solubility at different temperatures and N mineralized during soil incubation for some organic products (expressed in % of organic products N).

However this approach is relatively static by providing chemical indexes which characterize a given organic product. No information is provided on N mineralization kinetics and the variability of the product is not taken into account. By another way, it may be wondered about the agronomical significance of the defined fractions considering N availability or behaviour of organic products under field conditions. Nevertheless, these analytical determinations are rapid, simple and easy to perform for a routine analysis laboratory. They will be very useful if chemical tests data are in good agreement with N mineralization data obtained with soil incubation methods.

#### 4. Conclusions

All data collected with methods described previously are necessary for the parametrization of different kind of models. It includes mechanistic models which are used to describe C and N transformations in soil and which require the description of residues with different fractions, decomposition and assimilation rates. Decision making tools which are used to manage N fertilization (e.g. Azobil, published by Machet *et al.*, 1990) will directly integrate immediate N values and longer effects on soil N mineralization. Data will be also taken into account by functional crop simulation models (e.g. STICS, published by Brisson *et al.*, 1998) which simulates the behaviour of the soil-crop-system and are used to evaluate agronomic scenarios.

Data can be equally necessary to elaborate decision making tools which will be used by agro-industry to manage spreading areas. At the present time, management of the input of liquid effluents in the soil only takes into account amounts of water and approximative N values. Incorporating, precise N values, kinetics of mineralization and long term effects will improve N management in these areas.

Finally, data will be essential to propose some simple chemical indexes which may be used by laboratories to analyze rapidly and at a low cost N availability of organic products. Nevertheless proposed methods will probably have to take into account nature and type of organic products.

#### References

- Afnor** (1988). Norme française NFU 42-191. Détermination des formes d'azote dans un engrais azoté contenant de l'azote de synthèse organique. Afnor, Paris, 12 p.
- Bould C.** (1948). Availability of nitrogen in composts prepared from waste materials. *Emp J. Exp. Agric.*, 16, 103-110.

**Bourgeois S., Michelin J., Fumery H., Wiart J.** (1996). La valeur azotée des boues résiduelles des stations d'épuration urbaines. Ademe, Angers, 336 p.

**Brisson N. et al.** (1998). STICS: a generic model for the simulation of crops and their water and nitrogen balance. I. Theory and parametrization applied to wheat and corn. *Agronomie*, (submitted for publication).

**Bundy L.G., Meisinger J.J.** (1994). Nitrogen availability indices. *In* Methods of soil analysis. Part 2. Microbiological and biochemical properties (Weaver R.W. et al., eds), Soil Science Society of America Books Series, 5, 951-984, SSSA, Madison, WI.

**Burns I.G.** (1976). Equations to predict the leaching of nitrate uniformly incorporated to a known depth or uniformly distributed throughout a soil profile. *J. Agric. Sci. Camb.*, 86, 305-313.

**Castellanos J.Z., Pratt P.F.** (1981). Mineralization of manure nitrogen. Correlation with laboratory indexes. *Soil Sci. Soc. Am J.*, 45, 354-357.

**Chaussod R., Germon J.C., Catroux G.** (1981). Essai de détermination au laboratoire de l'aptitude à la minéralisation d'azote des boues résiduelles urbaines. *C.R. Acad. Agric. Fr.*, 67, 762-771.

**Chaussod R., Justes E., Linères M., Bourgeois S.** (1997). Valorisation des déchets urbains et agro-industriels. *In* Maîtrise de l'azote dans les agrosystèmes (Lemaire G., Nicolardot B., eds), 255-270, INRA Editions, Versailles.

**Chèneby D., Nicolardot B.**, (1992). Use of mineralization kinetics to estimate the agricultural value of organic fertilizers. *In* Composting and compost quality assurance criteria. (Jackson D.V., Merillot J.M., L'Hermite P., eds), 188-196, Commission of the European Communities, Brussels.

**Chèneby D., Nicolardot B., Godden B., Penninckx M.** (1994). Mineralization of composted <sup>15</sup>N-labelled farmyard manure during soil incubations. *Biol. Agric. Hort.*, 10, 255-264.

**Douglas B.F., Magdoff F.R.** (1991). An evaluation of nitrogen mineralization indices for organic residues. *J. Environ. Qual.*, 20, 368-372.

**Jarvis S.C., Stockdale E.A., Shepherd M.A., Powlson D.S.** (1996). Nitrogen mineralization in temperate agricultural soils: processes and measurement. *Advances in Agronomy* (Sparks D.L., ed.), 57, 188-235.

**Justes E., Mary B., Nicolardot B., Robert P.** (1998). Nitrogen availability of agro-industrial waste water: consequences for N management in spreading areas. *In* Proceedings of the 11<sup>th</sup> world fertilizer congress, 7-13 September 1997, Ghent, Belgium (in press).

**Machet J.M., Dubrulle P., Louis P.** (1990). Azobil: a computer program for fertilizer N recommendations based on a predictive balance sheet method. *In* Proceedings of the 1<sup>st</sup> congress of ESA, S2-21.

**Mary B.** (1996). Notice de LIXIM. Rapport de l'unité d'agronomie INRA de Laon-Péronne, Laon, France, 28 p.

**Premi P.R., Cornfield A.H.** (1971). Incubation study of nitrogen mineralisation in soil treated with dried sewage sludge. *Environ. Pollut.*, 2, 1-5.

**Recous S.** (1994). Réponse des matières organiques des sols aux changements atmosphériques globaux. II. Effet de la température sur la minéralisation d'un résidu végétal (maïs) et de la matière organique du sol. *Dossier de l'environnement de l'INRA*, 8, 81-85.

**Recous S., Robin D., Darwis D., Mary B.** (1995). Soil inorganic N availability: effect on maize residue decomposition. *Soil Biol. Biochem.*, 27, 1529-1538.

**Rodrigo A., Recous S., Neel C., Mary B.** (1997). Modelling temperature and moisture effects on C-N transformations in soils: comparison of nine models. *Ecol. Model.*, 102, 325-339.

**Stanford G.** (1982). Assessment of soil nitrogen availability. *In* Nitrogen in agricultural soils (Stevenson F.J., ed.), *Agronomy*, 22, 651-688, ASA-CSSA-SSSA Publisher, Madison, WI.

**Stanford G., Smith S.J.** (1972). Nitrogen mineralization potentials of soils. *Soil Sci Soc. Am. J.*, 36, 465-472.

**Yadvinder-Singh, Bijay-Singh, Maskina M.S., Meelu O.P.** (1998). Effect of organic manures, crop residues and green manure (*Sesbania aculeata*) on nitrogen and phosphorus transformations in a sandy loam at field capacity and under waterlogged conditions. *Biol. Fertil. Soils*, 6, 183-187.

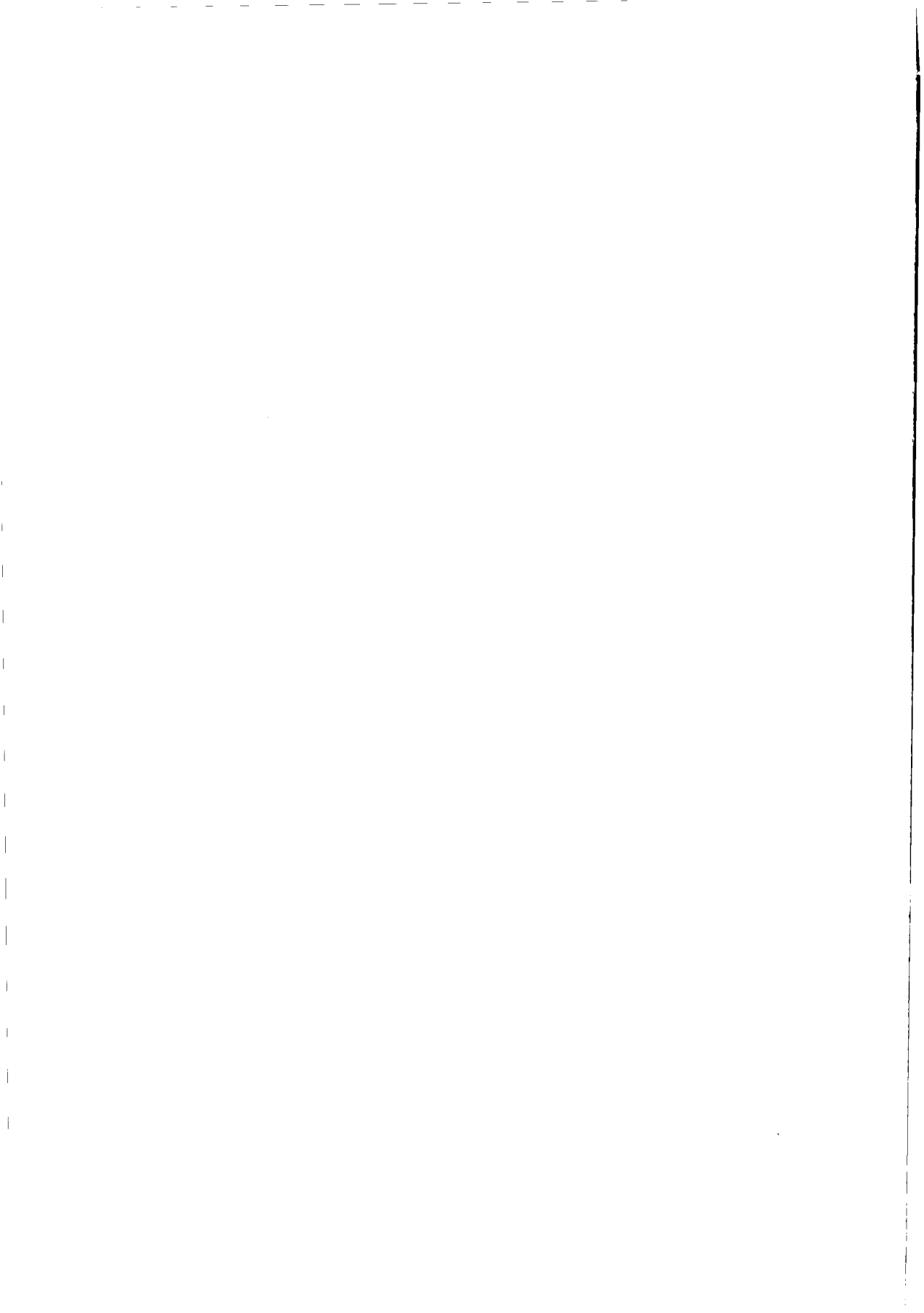

## **A model approach for ammonia volatilisation after surface application and subsequent incorporation of manure on arable land.**

*Une approche par modélisation de la volatilisation de l'ammoniac après épandage  
en surface ou après incorporation au sol de déjections animales.*

**J.F.M. Huijsmans and R.M. de Mol**

DLO-Institute of Agricultural and Environmental Engineering (IMAG-DLO),  
Wageningen, The Netherlands

E-mail : J.F.M.Huijsmans@imag.dlo.nl

### **Abstract**

*When applying manure to arable land by surface spreading, volatilisation of ammonia takes place. Reduction of ammonia volatilisation can be achieved by incorporation of the manure into the soil. The degree of reduction depends on the method of incorporation and the time-lag between application and incorporation. In general, direct incorporation with a mouldboard plough gives higher reductions than incorporation by a fixed tine cultivator. However, in reality there will always be some time between the spreading and incorporation and during this time volatilisation of the ammonia from the surface-applied manure takes place. The time-lag between application and incorporation depends on the dimensions of the plot, the working width and working speed of the machines and on the work organisation: two-man system, i.e. spreading and incorporation simultaneously, or one-man system, i.e. spreading and incorporation consecutively. To assess the ammonia volatilisation after spreading and incorporation of manure, the time-lag between these two operations was modelled via computer simulation. In a case study the effects on the reduction of volatilisation of the capacities of an incorporator and spreader were shown. Simulation showed that incorporation by a mouldboard plough does not always result in lower ammonia volatilisation than incorporation by a fixed tine cultivator due to differences in capacity. The plot size, work capacity of the spreader, work organisation, incorporation method and capacity, volatilisation rate of surface applied manure, etc. affect the overall ammonia volatilisation. The model showed to be a good instrument to evaluate the effects of different management strategies for manure spreading and incorporation on the ammonia volatilisation when applying and incorporating manure on plot scale.*

## Résumé

Lorsque les déjections animales sont épandues sur les terres, l'ammoniac se volatilise. La réduction de ce processus de volatilisation ammoniacale peut être obtenue par incorporation des déjections (lisiers) au sol. Le niveau de réduction dépend principalement de la méthode d'incorporation et du délai entre l'épandage et l'incorporation. En général, l'incorporation directe par retournement labour permet de meilleurs taux de réduction que l'incorporation par dents rigides (cultivateur fixe). Cependant, il y a toujours un délai entre l'épandage et l'incorporation et l'ammoniac se volatilise pendant ce délai. Ce délai entre épandage et incorporation dépend de la surface de la parcelle, la largeur de passage de l'épandeur et de la vitesse de travail des équipements et globalement de l'organisation du chantier d'épandage : système avec deux opérateurs (soit épandage et incorporation simultanés), ou système avec un opérateur donc épandage et incorporation consécutifs. Afin de vérifier la volatilisation de l'ammoniac ce délai entre les deux opérations a été modélisé. A travers l'étude d'un cas, l'effet sur la réduction de la volatilisation des capacités d'un épandeur et d'un enfouisseur a été établi. Les simulations démontrent que l'incorporation par labour ne s'accompagne pas toujours de pertes en  $\text{NH}_3$  inférieures comparativement à l'incorporation par dents rigides, cela notamment à cause de différences de capacités. Le modèle s'avère un outil utile pour évaluer les effets de différents modes de gestion des épandages de déjections et d'incorporation sur la volatilisation de l'ammoniac.

## 1. Introduction

When applying manure to arable land by surface spreading, volatilisation of ammonia takes place. Reduction of ammonia volatilisation can be achieved by incorporation of the manure into the soil. The degree of reduction depends on the method of incorporation. The manure can be directly injected into the soil or, after surface spreading, be incorporated by different tillage implements.

Huijsmans<sup>1</sup> (1991) compared the ammonia losses after applying slurry with an arable land injector equipped with spring tines with the losses when using the spring tines to incorporate surface applied manure. The injector placed the manure directly underneath the soil surface, at the same time carrying out a tilling operation by burying the manure with soil; the incorporation of the manure by the spring tines resulted in mixing the manure and soil and partly burying the manure with soil. Injection almost completely prevented any ammonia volatilisation.

Different tilling techniques have been investigated in recent years to reduce volatilisation (Van de Molen et al.<sup>2</sup>, 1990; Huijsmans<sup>1</sup>, 1991; Mulder and Huijsmans<sup>3</sup>, 1994; Huijsmans and Hol<sup>4</sup>, 1995). It was shown that the degree of volatilisation depends on the method of incorporation. Soil type, soil condition and incorporation technique may determine the volatilisation rate. Burying and intensive mixing of the manure with the soil (increased interaction between soil and manure) resulted in a higher reduction of the volatilisation. Complete burying of the manure by the mouldboard plough gave 90% reduction compared to surface spreading.

Depending on the intensity of mixing of the manure with the soil and the soil condition, other tillage implements achieved a reduction of the volatilisation from 40% to more than 90%. Experiments in which the incorporation was delayed by 3 and 6 hours showed a higher volatilisation compared with direct incorporation <sup>4</sup>.

All data on ammonia losses after manure application and incorporation are derived from trials in which incorporation took place directly or at a set time following the spreading on a small scale field plot. However, in reality there will always elapse time between the spreading and incorporation, and this period is not precisely controlled. The ammonia volatilisation rate from surface-applied manure is not linear with time but peaks the first hours after spreading (Figure 1). When manure is spread and incorporated on farm field scale the time between spreading and incorporation thus affects the overall ammonia volatilisation.

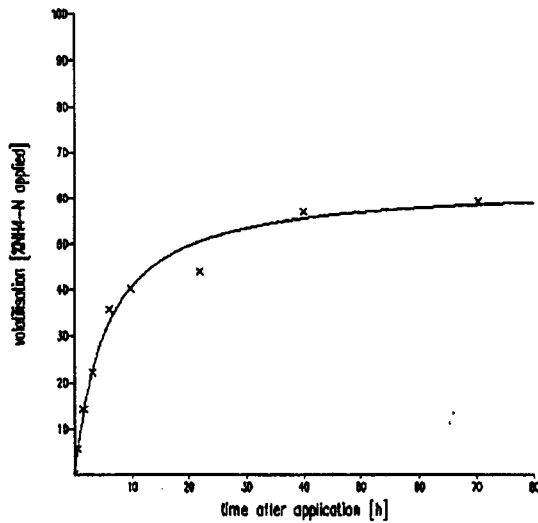

Figure 1  
Cumulative ammonia volatilisation after slurry application as a percentage of the ammonium nitrogen applied (after Huijsmans and Hof<sup>4</sup>, 1995)

The time to carry out field operations such as manure spreading and a tillage operation depends on the circumstances (such as dimensions of plot, working speed and width of the implements) and the work organisation (Hunt<sup>5</sup>, 1986; Witney<sup>6</sup>, 1995). To assess the ammonia volatilisation from manure applied and incorporated in two sequential operations, the time-lag between spreading and incorporation needs to be known. Combining this time-lag with a volatilisation curve of surface-applied manure and the potential volatilisation reduction by a particular tillage implement will give the actual volatilisation of a manured field.

In different countries in Europe the reduction of ammonia losses is a big issue to control environmental pollution. One of the policies to reduce ammonia losses is incorporation of surface-applied manure. To investigate the effectiveness of



incorporation of surface-applied manure a computer model was developed to simulate the spreading and incorporating operations and to calculate the ammonia volatilisation. In the present study the factors that affect the time-lag between spreading and incorporation are analysed to assess the reduction of ammonia volatilisation of a manured and incorporated plot.

## 2. Materials and methods

A simulation model was developed to calculate the relation between the time-lag between spreading and incorporation, and ammonia volatilisation for each point of an arable plot. The time-lag depends on the circumstances (dimensions of plot, working speed and width of the machines, distance to manure storage, etc.) and the work organisation: two-man system, i.e. spreading and incorporation simultaneously, or one-man system, i.e. spreading and incorporation consecutively.

In the model the time-lag is calculated by simulation of the activities on the plot. Given the time-lag, the volatilisation is determined by the volatilisation function and the reduction of the volatilisation by the incorporation implement. A combination of the time-lag and the volatilisation gives the average volatilisation and the reduction of the volatilisation for the whole plot. Furthermore, the model gives the average time delay and a division of the time spent over the activities spreading and incorporation.

### 2.1. Process description

In practice a manure spreader applies the manure on a plot until the whole plot is manured. Each time the spreader is empty it is driven to a manure storage to reload. The manure storage can be nearby at the side of the field or located at some distance. Incorporation can start during or after the manuring of the plot. To calculate the actual time-lag between spreading and incorporation some activities and process parameters need to be defined.

#### 2.1.1. Definitions

A rectangular plot is considered (Figure 2). The operations application and incorporation of manure are performed in **passes** to and fro across the plot. Two successive passes form a **round**. The application equipment is called the **spreader** and the incorporation equipment is called the **incorporator**. Both the spreader and the incorporator have a working speed and a working width. The **capacity** of the incorporator is defined as the working speed times the working width. This is the work capacity neglecting turning and waiting time. The capacity of the spreader is also the work capacity, neglecting turning time, but taking the time for reloading into account. The reloading time is the combination of time required for driving to and from the storage, handling and turning at the manure storage and filling the spreader.

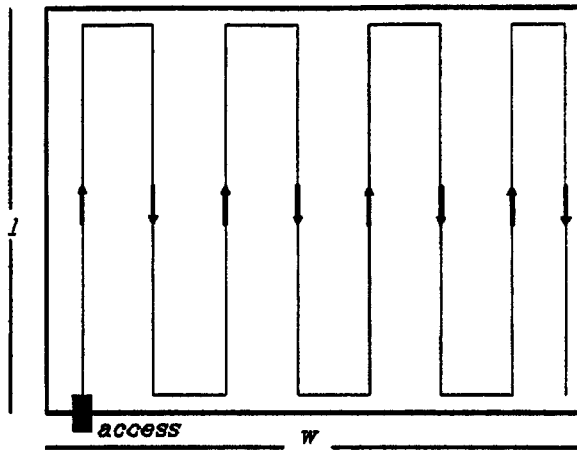

Figure 2

Scheme of a plot (length  $l$  and width  $w$ ) and passes of an implement.

More formally the capacity of the incorporator is defined as:

$$Cap_i = \frac{w_i \cdot v_i}{10} \quad (1)$$

with :

- $Cap_i$  capacity of the incorporator [ $ha \cdot h^{-1}$ ]
- $w_i$  working width of the incorporator [m]
- $v_i$  working speed of the incorporator [ $km \cdot h^{-1}$ ]

The capacity of the spreader is defined by:

$$Cap_s = \frac{1}{\left( \frac{10}{w_s \cdot v_s} + \frac{m_s \cdot r_s}{p_s} \right)} \quad (2)$$

with :

- $Cap_s$  capacity of the spreader [ $ha \cdot h^{-1}$ ]
- $w_s$  working width of the spreader [m]
- $v_s$  working speed of the spreader [ $km \cdot h^{-1}$ ]
- $m_s$  manure application rate [ $m^3 \cdot ha^{-1}$ ]
- $r_s$  reloading time per tank load [h]
- $p_s$  pay load per tank [ $m^3$ ]

### 2.1.2. Work organisation

The process of application and incorporation of manure is influenced by many factors. Technical factors are the dimensions of the plot, the working speeds, the working widths, the manure application rate and the pay load of the spreader. Also two main types of work organisation can be distinguished :

#### 1) Working method for manure application

Three working methods are being considered :

- **whole rounds**: a new round (to and fro) is started only if there is enough manure in the tank, otherwise the tank is loaded first;
- **whole passes**: a new pass (there or back) is started only if there is enough manure in the tank, otherwise the tank is loaded first;
- **interrupted passes**: application continues till the tank is empty; after reloading the interrupted pass is continued in the same direction and at the same place where it stopped before loading.

-

#### 2) Working method for manure incorporation

Application and incorporation can be carried out simultaneously (**two-man system**) or consecutively (**one-man system**);

In a **two-man system** one person is available for manure application and another one for incorporation. The spreader and the incorporator can work independently. The spreader is applying manure, alternated with loading of the tank if needed. Loading is done before a new round, before a new pass or when the tank is empty, depending on the chosen working method. The incorporator starts when there is enough manured land available for a whole round or at a later stage after a set waiting time. The incorporator is continuously making whole rounds over the plot. Interruptions can occur when the incorporator catches up with the spreader due to a relative high work capacity of the incorporator or when loading of the spreader takes a lot of time. The incorporator waits till a whole manured round can be incorporated.

In a **one-man system** one person alternates spreading and incorporating; spreader and incorporator are alternately active. The spreader starts with loading of the tank and is working till the tank needs to be reloaded. The spreader drives to the access of the plot, the operator steps over to the incorporator and starts to incorporate the surface-applied manure. After the incorporation the incorporator drives to the access of the plot, the operator steps over on the spreader and continues by loading it. The incorporator makes as many whole rounds as possible, after which a change over to the spreader takes place at the access. This sequence is repeated till manure is applied and incorporated on the whole plot.

## 2.2. Model description -

### 2.2.1. Volatilisation

The ammonia volatilisation of applied manure can be divided into the volatilisation until incorporation and the volatilisation after incorporation. A volatilisation model was made that calculates the total volatilisation for each point of the plot (before and after incorporation) taking into account the time-lag between the spreader and incorporator at that point of the plot. To achieve this the plot was divided into **strips** (Figure 3). The volatilisation was first calculated per strip and later averaged over all the strips to assess the total emission of the plot. The length of a strip equalled the length of the plot; the strip width was taken as the greatest common divisor of the working widths and the plot width. Both the spreader and the incorporator operated on an integer number of strips in each pass.

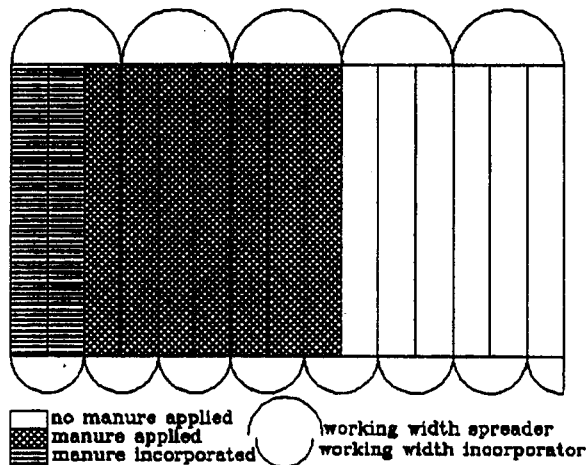

Figure 3

Example of a situation during simulation on a plot divided into 15 strips, where manure has been applied on nine strips and where two strips have been incorporated.

The model for the volatilisation until incorporation is based on experiments in which the volatilisation was determined as a function of the time after application (Figure 1). A non-linear volatilisation function can be fitted for this curve :

$$Vol(\Delta t) = \frac{\Delta t}{\beta_0 + \beta_1 \cdot \Delta t} \quad (3)$$

with :

- $\Delta t$  time-lag between application and incorporation [h]
- $Vol(\Delta t)$  Ammonia volatilisation for time-lag  $\Delta t$  [% of total  $NH_4-N$  applied]
- $\beta_0$  and  $\beta_1$  Parameters of the volatilisation function [ $h \cdot \%^{-1}$ ], [ $\%^{-1}$ ]

The parameters  $\beta_0$  and  $\beta_1$  are fitted by using the results of experiments in which the volatilisation of non-incorporated manure is measured.

The time-lag  $\Delta t$  depends on the operating direction of the spreader and incorporator :

– if the incorporator operates in the same direction on a strip as the spreader, then:

$$\Delta t(x) = \left( t_{oi} + \frac{x}{v_i} \right) - \left( t_{os} + \frac{x}{v_s} \right) \quad (4a)$$

– if the incorporator operates in a direction on a strip opposite to the spreader, then:

$$\Delta t(x) = \left( t_{oi} + \frac{x}{v_i} \right) - \left( t_{os} + \frac{l-x}{v_s} \right) \quad (4b)$$

with:

- $x$  location on the strip,  $0 \leq x \leq l$  [km]
- $\Delta t(x)$  time-lag at point  $x$  [h]
- $t_{oi}$  time the incorporator started with the strip [h]
- $t_{os}$  time the spreader started with the strip (equals 0 for the start of the simulation) [h]
- $l$  length of a strip (equals the length of the plot) [km]

The average volatilisation until incorporation for a strip  $j$  is :

$$Vol_{u,j} = \frac{1}{l} \int_{x=0}^{x=l} Vol(\Delta t(x)) dx = \frac{v_i}{l} \int_{t=0}^{t=t_i} Vol(\Delta t(v_i \cdot t)) dt \quad (5)$$

with :

- $Vol_{u,j}$  average volatilisation until incorporation for strip  $j$  [% of total  $NH_4-N$  applied]
- $t_i$  time needed by the incorporator to incorporate a whole strip [h]

The transformation  $x = v_i \cdot t$  is applied to transform the place-dependent integral to a time-dependent integral that can be used in the simulation model.

The average volatilisation after incorporation for a strip  $j$  is :

$$Vol_{a,j} = \frac{100 - PotRed_i}{100} \cdot (Vol(\infty) - Vol_{u,j}) \quad (6)$$

with :

- $Vol_{a,j}$  volatilisation after incorporation for strip  $j$  [% of total  $NH_4-N$  applied]
- $PotRed_i$  potential volatilisation reduction of the incorporator [%]
- $Vol(\infty)$  total ammonia volatilisation of surface-applied manure after Eqn (3) [% of total  $NH_4-N$  applied]

The volatilisation after incorporation at varying time-lags after spreading is generally not known. In experiments the volatilisation after incorporation was measured in trials in which manure was incorporated directly or at a set time following spreading on a small scale field plot<sup>1,2,3,4</sup>. The measured volatilisation reduction when direct incorporating is used in the model as the potential reduction in volatilisation of the incorporator  $PotRed_i$ . This potential reduction is assumed to be constant for each incorporation method independent of the time-lag between spreading and incorporation. For example, if incorporation with a plough gives a reduction of 90% in case of direct incorporation (potential volatilisation reduction), then this percentage of reduction is also assumed for the remaining volatilisation after a

certain time-lag. This means that 10% of the ammonia that would have volatilised from that moment, in case of no incorporation, is volatilised when incorporating at that moment.

The average total volatilisation for strip  $j$  is the sum of the volatilisation until incorporation and the volatilisation after incorporation :

$$Vol_j = Vol_{u,j} + Vol_{a,j} \quad (7)$$

with:

$Vol_j$  volatilisation until and after incorporation for strip  $j$  [% of total  $NH_4-N$  applied]

The average total volatilisation of the whole plot is the average over all strips :

$$Vol = \frac{1}{N} \sum_{j=1}^N Vol_j \quad (8)$$

with :

$Vol$  average volatilisation for the whole plot [% of total  $NH_4-N$  applied]  
 $N$  number of strips

### 2.2.2. Process simulation

To determine the time-lag between the spreader and the incorporator the process of application and incorporation of manure was simulated by the simulation model CAESAR (Computer simulation of the Ammonia Emission of Slurry application and incorporation on ARable land). The model works with the simulation software package PROSIM (Prosim<sup>7</sup>, 1994). PROSIM makes it possible to simulate discrete and continuous processes simultaneously. Spreading and incorporating are continuous processes interrupted at discrete moments for turning, reloading or waiting. The processes are simulated according to the description in section 2.1.

In a two-man system, the spreader is continuously making passes on the plot and reloading the tank, till the whole plot is manured. In this case the activities of the incorporator may depend on the activities of the spreader; the incorporator can only start a new round if enough manured land is available to make a whole round. In a one-man system, the spreader and the incorporator are alternately active.

Input for the simulation model exists of parameters of volatilisation, spreader and incorporator as well as general parameters.

#### General parameters :

- one-man or two-man system
- whole round, whole passes or interrupted passes
- length of plot / [km]
- width of plot [km]
- strip width [m]
- manure application rate  $m_s$  [ $m^3 \cdot ha^{-1}$ ]
- idle travel speed on the field of the spreader and incorporator [ $km \cdot h^{-1}$ ]

- - waiting time for the incorporator in a two-man system
- - changing time from spreader to incorporator or reverse in a one-man system [min]

*Volatilisation parameters :*

Characteristics of the volatilisation function, i.e. parameters in Eqn (3)

*Spreader parameters :*

- working speed  $v_s$  [ $\text{km}\cdot\text{h}^{-1}$ ]
- working width  $w_s$  [m]
- pay load  $\rho_s$  [ $\text{m}^3$ ]
- time to turn [sec]
- travel speed on the road [ $\text{km}\cdot\text{h}^{-1}$ ]
- distance to manure storage [km]
- time for handling and turning before and after reloading [min]
- loading capacity [ $\text{m}^3\cdot\text{min}^{-1}$ ]

*Incorporator parameters:*

- working speed  $v_i$  [ $\text{km}\cdot\text{h}^{-1}$ ]
- working width  $w_i$  [m]
- time to turn [sec]
- potential volatilisation reduction of the incorporator  $PotRed_i$ , as defined in Section 2.2.1 [%]

The simulation starts with the spreader (with loaded tank) and incorporator ready at the access to the plot. The access to the plot is located in the corner of the plot (Figure 2). In the model the spreader can be busy with different activities: working, waiting, driving on the plot, reloading, turning. The incorporator may be working, waiting, driving on the plot or turning. In the one-man system also changing from spreader to incorporator or reverse takes place. Figure 3 shows a possible situation during a simulation run.

The main results generated by the simulation model are :

- average time-lag between application and incorporation;
- average volatilisation until incorporation;
- average total volatilisation (before and after incorporation);
- average reduction in volatilisation (compared with no incorporation at all);
- total time needed for application and incorporation;
- division of the total time over the different activities of the spreader and the incorporator.

### 3. Simulations

With the model many different situations can be simulated and the results are used to calculate the total volatilisation from a manured and incorporated plot and time needed for application and incorporation. From the model description it is expected that the capacity of the spreader ( $Cap_s$ ) and the incorporator ( $Cap_i$ ) as defined in Eqn

(1) and (2), will have a major effect on the reduction of the volatilisation. The volatilisation when spreading and incorporating in two gangs can approach the volatilisation of direct incorporation when the difference between the capacities of the spreader and the incorporator is minimised: the potential volatilisation reduction of the incorporator is approached. In the following case this hypothesis is tested by studying the relation between the capacity of the incorporator ( $Cap_i$ ) and the spreader ( $Cap_s$ ) and the resulting reduction of the volatilisation compared with no incorporation, taking into account different potential volatilisation reduction rates of the incorporator.

### 3.1. Input parameters

The plot size is taken 4.8 ha (length 0.2 km and width 0.24 km) and the strip width is 0.5 m. After each pass along the plot both the spreader and the incorporator turn; the time to turn is 20 and 30 s respectively. The travel speed of the spreader and incorporator on the field, while not in operation, is  $10 \text{ km}\cdot\text{h}^{-1}$ . The two-man system and whole rounds are assumed. At the beginning the incorporator starts 3 min later than the spreader if there is enough manured land available for a whole round. The manure storage is placed at the edge of the field near the access; eliminating road transport to a manure storage. The loading capacity of the spreader is  $3 \text{ m}^3\cdot\text{min}^{-1}$ , handling and turning before and after the loading of each load takes altogether 2 min.

The potential volatilisation when the manure is not incorporated is based on the volatilisation as shown in Figure 1. Fitting Eqn (3) results in the parameter values:  $\beta_0 = 0.087$  and  $\beta_1 = 0.016$  (accounts for 98.5% of the variance). The maximum volatilisation, when not incorporating, is 60% of the total ammonia applied.

To study the effect of the relation between the capacity of the incorporator ( $Cap_i$ ) and the spreader ( $Cap_s$ ) on the reduction of the volatilisation, taking into account different potential volatilisation reduction rates of the incorporator, a selection is made of a range of practical possibilities in Dutch circumstances. For the spreader the following situations were considered :

- working speed  $v_s$ : 6, 8 or  $10 \text{ km}\cdot\text{h}^{-1}$  (n = 3);
- working width  $w_s$ : 8, 10 or 12 m (n = 3);
- pay load  $p_s$  varying from 6 to  $22 \text{ m}^3$ , with steps of  $2 \text{ m}^3$  (n = 9);
- manure application rate  $m_s$ : 10, 15, 20, 25, 30, 35, 40, 50 and  $60 \text{ m}^3\cdot\text{ha}^{-1}$  (n = 9).

These situations yield 729 ( $3 \times 3 \times 9 \times 9$ ) possible combinations for the spreader. Tuning the pay load of the spreader with the manure applied for an integer number of rounds (practice) eliminates unpractical combinations resulting in 189 remaining combinations. For 18 combinations with a high application rate the working method with whole rounds was impossible, the method with whole passes was used instead.



For the incorporator the following situations were considered:

- working speed  $v_i$  varying from 2 to 10  $\text{km}\cdot\text{h}^{-1}$ ,  
with steps of 2  $\text{km}\cdot\text{h}^{-1}$  (n = 5);
- working width  $w_i$ : 1, 1.5, 2, 2.5, 3, 4, 5 and 6 m (n = 8);
- potential volatilisation reduction  $PotRed_i$  varying from 40 to 90%,  
with steps of 10% (n = 6).

These situations yield 240 (5×8×8) possible combinations for the incorporator. The working speed of the incorporator was chosen in a range in which most tillage implements may work in suitable soil conditions. The working widths were chosen in the way that the smaller working widths were more common for a plough and the larger ones for a cultivator. The potential volatilisation reductions of the incorporator corresponded with different kinds of measured reductions<sup>1,2,3,4</sup>.

The total number of combinations for the spreader and the incorporator is 45360 (189 × 240). For the simulations a random selection of 10 spreader combinations was made (Table 1). Each of these combinations was combined with all 240 incorporator combinations to analyse the volatilisation reduction when applying and incorporating manure on a whole plot.

### 3.2. Simulation results

The resulting spreader capacity of the 10 randomly selected spreader combinations is given in Table 1. For spreader combination 1 (capacity 2.93  $\text{ha}\cdot\text{h}^{-1}$ ) the relation between reduction of the volatilisation and the capacities of the incorporator is shown for the different potential volatilisation reduction in Figure 4.

number	working speed $v_s$ [ $\text{km}\cdot\text{h}^{-1}$ ]	working width $w_s$ [m]	application rate $m_s$ [ $\text{m}^3$ ]	pay load $\rho_s$ [ $\text{m}^3$ ]	reloading time $r_s$ [h]	capacity [ $\text{ha}\cdot\text{h}^{-1}$ ]
1	6	8	15	10	0.09	2.93
2	6	15	10	6	0.07	4.50
3	8	10	25	20	0.14	3.27
4*	8	15	40	12	0.10	2.40
5	10	8	15	10	0.09	3.87
6	10	8	60	20	0.14	1.79
7	10	12	15	22	0.16	5.28
8	10	12	20	20	0.14	4.39
9	10	15	25	16	0.12	3.88
10*	10	15	60	18	0.13	1.96

\* spreader combination where whole rounds are not possible

*Table 1*  
*Parameter values for the 10 randomly selected spreader combinations and their capacity*

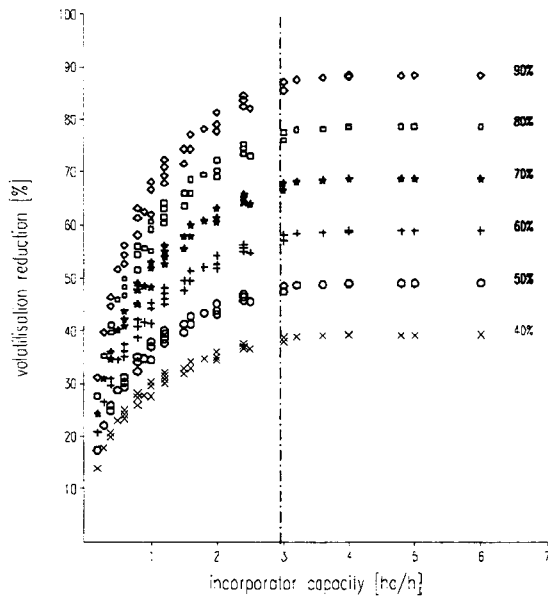

Figure 4

*Volatilisation reduction as a function of the capacity of the incorporator for the first spreader combination; for six levels of potential volatilisation reduction of the incorporator (the vertical line shows the capacity of the spreader).*

As the incorporator capacity increased, the reduction approached the maximum level of reduction, which corresponded with the potential reduction of the incorporator at direct incorporation. This maximum volatilisation reduction was reached when the capacity of the incorporator was at least as high as the capacity of the spreader. The vertical line in Figure 4 shows the capacity of the spreader. Increasing the capacity of the incorporator after this point will not increase the reduction of volatilisation. The reduction was lower when the capacity of the incorporator was lower; at this stage there was a non-linear relationship between the capacity of the incorporator and the reduction of volatilisation.

Characteristics of Figure 4 proved to be also apparent for the other nine spreader combinations mentioned in Table 1. This finding means that it may be possible to estimate the reduction of volatilisation for this plot size given only the capacities of the spreader and the incorporator. However, the point where the maximum level of reduction can be approached will be determined by the point where the capacity of the incorporator equals the capacity of the spreader.

## 4. Discussion

Some incorporators as defined in section 3.1 have the same capacity, e.g. a capacity of  $1.2 \text{ ha}\cdot\text{h}^{-1}$ , when the working width is 2 m and the working speed is  $6 \text{ km}\cdot\text{h}^{-1}$  (case 1), but also when the working width is 3 m and the working speed is  $4 \text{ km}\cdot\text{h}^{-1}$  (case 2). The related volatilisation reduction differs, as can be seen in Figure 4, but this difference is relatively small. For example, in case of 70% potential reduction of the incorporator the reduction of volatilisation is 53.9% (case 1) and 55.1% (case 2). For incorporators with the same capacity, the highest volatilisation reduction is reached for the incorporator with the greatest working width, which can be explained by smaller total turning time.

The potential volatilisation reduction of an incorporator can never be reached, because the time-lag between spreader and incorporator never equals zero. In the simulation model it is assumed that the incorporator starts with a new round only when enough manured strips are available for a whole round; during this waiting time volatilisation takes place.

In the case study the effect of the capacity of the incorporator on the reduction of volatilisation was presented for a given set of capacities of the spreader. Changes in the capacity of the spreader will directly show at which stage a maximum reduction of volatilisation can be reached by the incorporator, as is shown in Figure 3 by the vertical line. The capacity of the spreader depends on different aspects. The manure application rate and the payload of the tank determine the number of refillings of the tank for a certain plot. The total refilling time depends on the distance to the storage, loading time and travel speed. The working width, working speed and turning times on the plot determine the time for the actual spreading. Changes in these parameters will effect the spreader capacity and so at which the stage a maximum reduction of volatilisation can be reached by an incorporator.

The reduction of volatilisation for two potential reductions of volatilisation of the incorporator is shown for varying capacities of the incorporator in Figure 5. This figure is suitable to analyse the reduction of volatilisation when choosing different kinds of tillage implements to incorporate the manured plot, given the potential volatilisation reduction of the incorporator and its incorporation capacity. For example, a mouldboard plough will give a potential volatilisation reduction of 90% and a spring tine cultivator 50%. Taking spreader combination 1 from Table 1, the volatilisation reduction can be calculated (Figure 5). The plough may have a working speed of  $3 \text{ km}\cdot\text{h}^{-1}$  and a working width of 1.5 m (capacity  $0.45 \text{ ha}\cdot\text{h}^{-1}$ ); the spring tine  $8 \text{ km}\cdot\text{h}^{-1}$  and 6 m, respectively (capacity  $4.8 \text{ ha}\cdot\text{h}^{-1}$ ). From Figure 5 it can be read that the mouldboard plough results in a reduction of 46% and the spring tine cultivator in 49%. This example shows that though the potential reduction of the plough is higher than the potential reduction of the spring tine cultivator, the overall volatilisation reduction of the plough is lower when incorporating a whole manured plot. A higher capacity of the plough (more than  $0.5 \text{ ha}\cdot\text{h}^{-1}$ ) will result in a higher volatilisation reduction than with the spring tine cultivator. In the same way the capacity of the spring tine cultivator may be lowered to  $2.2 \text{ ha}\cdot\text{h}^{-1}$  to reduce the volatilisation to the same level as the plough.

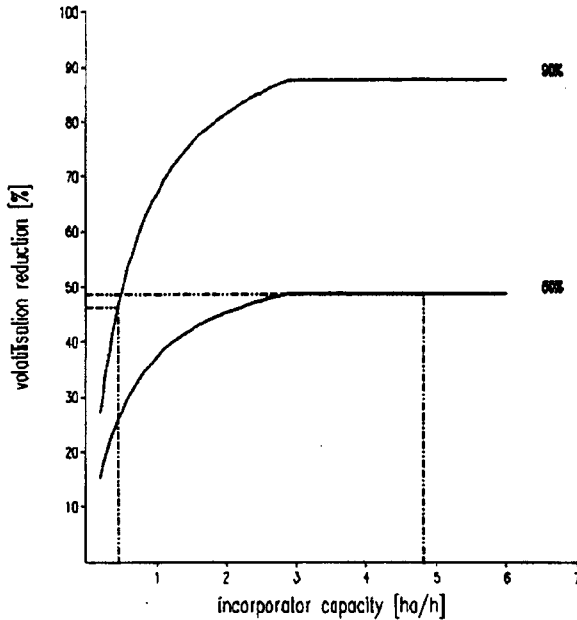

Figure 5

Volatilisation reduction as a function of the capacity of the incorporator for the first spreader combination ; for a potential volatilisation reduction of 90% (plough) and 50% (spring tine cultivator).

In the case study some features and possibilities of the model are described. Other parameter settings will result in other outcomes. For example, changing the plot size and/or the volatilisation function directly influences the outcome. However, the maximum volatilisation reduction is reached when the capacity of the incorporator is at least as high as the capacity of the spreader. The model makes it possible to study the volatilisation after incorporation for different situations. The model also gives the average time-lag and a division of the spent time over the activities for the spreading and incorporation implement. A next step in the research will be to optimise the process of spreading and incorporations in terms of ammonia losses versus costs.

## 5. Conclusion

Volatilisation and reduction of volatilisation after surface application and subsequent incorporation of manure on arable land was affected by the time-lag between spreading and incorporation. The CAESAR model enables the calculation of the time differences, between spreading and incorporation, and ammonia volatilisation for each point of an arable plot. The time-lag depended on the circumstances (such as dimensions of plot, working speed and width) and the work organisation.

The case study showed that incorporation by a plough not always results in lower ammonia volatilisation than incorporation by a spring tine cultivator in spite of the potential higher reduction of volatilisation by the plough. The input parameters plot size, work capacity of the spreader and the incorporation method, volatilisation rate of surface applied manure, etc. affected the overall ammonia volatilisation.

The model showed to be a good instrument to evaluate the effects of different manure spreading and incorporating management strategies on the ammonia volatilisation when applying and incorporating manure on plot scale.

## 6. References

1. **Huijsmans, J.F.M.** Possibilities for slurry application before and after drilling sugar beet. Proceedings 54th Winter Congress, Institut International de Recherches Betteravieres, Brussel, p. 109-124, 1991.
2. **Molen, J. van de, Faassen, H.G. van, Leclerc, M.Y., Vriesema, R. and Chardon, W.** Ammonia volatilisation from arable land after application of cattle slurry.1. Field estimates. Neth. Journal of Agricultural Science, 38/2, 145-158, 1990.
3. **Mulder, E.M. and J.F.M. Huijsmans.** Beperking ammoniakemissie bij mesttoediening. Overzicht metingen DLO-veldmeetploeg 1990-1993. DLO, Wageningen 71 pp, 1994.
4. **Huijsmans, J.F.M. and J.M.G. Hol.** Ammoniakemissie bij het in een tweede werkgang onderwerken van dunne varkensmest op bouwland. IMAG-DLO rapport 95-13, Wageningen, 32 pp, 1995.
5. **Hunt, D.R.,** 1986. Engineering models for agricultural Production. The Avi Publishing Company, Westport, Connecticut, 260 pp.
6. **Witney, B.D.,** 1995. Choosing & using farm machines. Land Technology Ltd., Edinburgh, 412 pp.
7. **Prosim,** 1994. Prosim User Guide, Sierenberg & de Gans bv, Waddinxveen, The Netherlands, 134 pp.

# Using a mechanistic model for evaluating ammonia emissions abatement techniques after organic fertilization

*Utilisation d'un modèle mécaniste pour évaluer des techniques de réduction des émissions d'ammoniac après fertilisation organique.*

**Génermont S., Cellier P.**

Institut National de la Recherche Agronomique,  
Unité de Recherches en Bioclimatologie, F-78850 Thiverval-Grignon, France  
E-mail : genermon@bcgn.grignon.inra.fr

## Abstract

*A mechanistic model of ammonia volatilization after liquid effluent spreading was used to investigate the efficiency of ammonia loss abatement techniques and strategies under a wide range of agricultural and environmental conditions. It proved to be a useful tool to compare these techniques, and to evaluate the conditions where they are the most efficient. It should thus be used further to help the farmers to choose between the practical strategies and methods aiming at reducing ammonia emissions after land disposal.*

**Keywords** : Ammonia volatilization, Mechanistic modeling, Organic manure, Abatement techniques

## Résumé

La réduction des émissions d'ammoniac après l'application d'effluents d'élevage ou urbains permettrait de limiter les pertes d'azote issues de l'activité agricole et les impacts environnementaux liés à l'augmentation de la concentration atmosphérique en ammoniac. Plusieurs approches se sont révélées efficaces pour limiter les pertes d'azote par les sols cultivés : elles incluent les modifications des propriétés des effluents, le travail du sol et une meilleure gestion des épandages. Cependant, les interactions fortes avec le climat, le sol et le lisier rendent difficile toute extrapolation. Nous avons développé un modèle mécaniste pour simuler la volatilisation à un pas de temps horaire, dans différentes conditions de sol, lisier et climat. Il a été utilisé pour tester ce type de techniques. En premier lieu, nous avons montré que les résultats des simulations avec le modèle concordaient avec des résultats publiés d'expérimentations au champ : l'amplitude de la réduction est bien reproduite pour l'acidification ou la dilution de l'effluent, et pour l'incorporation ou l'irrigation après l'apport. Ensuite, grâce à des simulations appropriées, le modèle a servi à évaluer et comparer l'efficacité de quelques techniques dans une large gamme de conditions agricoles et environnementales : par exemple, l'acidification n'est réellement efficace que sur une gamme limitée de pH, qui dépend en outre de la température ; l'irrigation est d'autant moins efficace que le sol est humide. Ce

modèle mécaniste est donc un outil utile pour améliorer la gestion des ressources agricoles et naturelles, et pour la protection de l'environnement. Il devrait être utilisé dorénavant pour proposer aux agriculteurs des stratégies et des méthodes pratiques visant à réduire les émissions d'ammoniac lors de la valorisation agricole des effluents.

**Mots-clés** : volatilisation d'ammoniac, modélisation mécaniste, amendement organique.

## 1. Introduction

Reducing ammonia emissions after farm or urban effluents application would minimize the great gaseous nitrogen loss from agriculture. Indeed ammonia emissions following slurry application account for almost one third of the European source of atmospheric ammonia (Buijsman *et al.*, 1987; ECETOC, 1994). In contrast to the other agricultural sources (animal housing, manure storage, grazed pasture), their emissions are time limited (several days to several weeks), intense just after application (several tens of  $\text{kg N-NH}_3 \text{ ha}^{-1} \text{ j}^{-1}$ ). Furthermore, they vary in a wide range (0-100% of ammoniacal N applied), depending on many features of the soil, climate and slurry (Jarvis and Pain, 1990; Générumont, 1996). They represent then great nitrogen losses for the agro-systems, which is a matter of considerable economical and environmental importance, but difficult to evaluate and to reduce.

Several techniques aim at reducing ammonia losses from cultivated soils: they include slurry properties modifications, soil management and better slurry application management (Hauck, 1983; Frost, 1994; Sommer and Hutchings, 1995). But ammonia volatilization is a complex process, involving many physical mechanisms, and the reducing techniques have strong interactions with the climatic, soil and slurry conditions (Jarvis and Pain, 1990). Their efficiency is thus difficult to extrapolate to other conditions. This paper aims at showing how a mechanistic volatilization model could help evaluating and comparing such techniques in a wide range of agronomic and environmental conditions. It is finally used to propose recommendations to farmers.

## 2. Materials and methods

### 2.1. Mechanistic model

The mechanistic model is derived from those of Rachhpal-Singh and Nye (1986) and van der Molen *et al.* (1990). It simulates volatilization at a hourly interval under various soil, slurry, climate conditions (Générumont and Cellier, 1997). It accounts for the main mechanisms implied in ammonia volatilization, water and ammoniacal N transfers, and equilibria in the topsoil and between the soil and the atmosphere (figure 1).

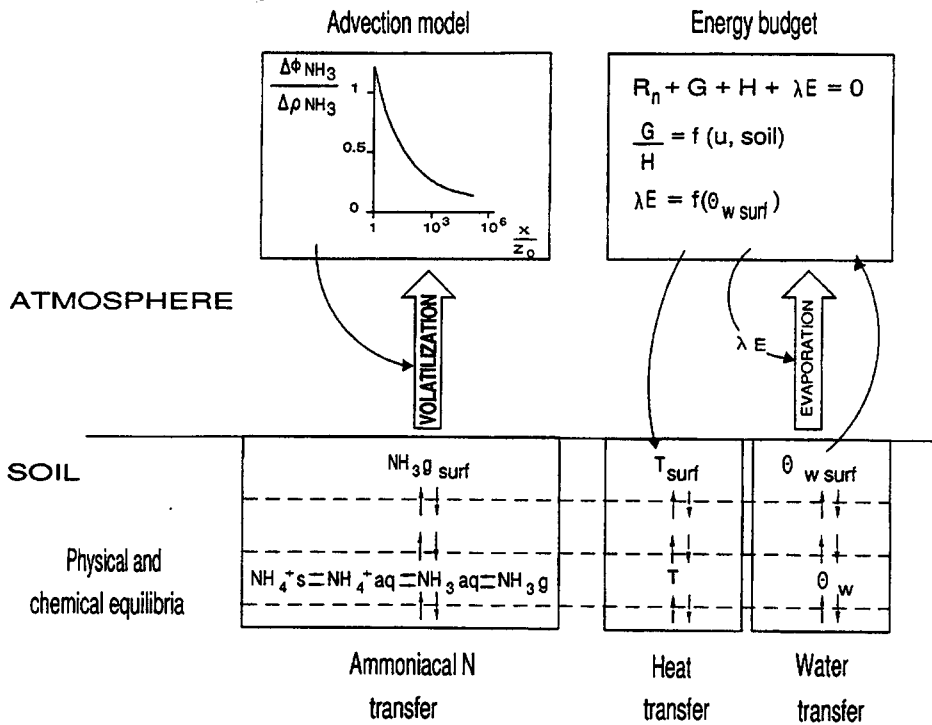

- |       |            |                                |                   |                             |
|-------|------------|--------------------------------|-------------------|-----------------------------|
| With: | $E$        | soil evaporation               | $x$               | abscise in wind direction   |
|       | $G$        | soil heat flux                 | $z_0$             | roughness length            |
|       | $H$        | atmospheric sensible heat flux | $\theta_v$        | soil water content          |
|       | $R_n$      | soil surface net radiation     | $\theta_{v surf}$ | soil surface water content  |
|       | $T_{sol}$  | soil temperature               | $\lambda$         | latent heat of vaporization |
|       | $T_{surf}$ | soil surface temperature       | $\rho_{NH_3}$     | atmospheric ammonia density |
|       | $u$        | wind speed                     | $\Phi_{NH_3}$     | ammonia flux                |

Figure 1  
Diagram of the volatilization model

- the relative proportions of ammonia and ammonium are calculated from the acid base equilibrium constant (1); the equilibrium between gaseous and solute ammonia is obtained from Henry's law (Beutier and Renon, 1978); adsorption by clays and organic matter of the soil is described using a Freundlich isotherm (Rachhpal-Singh and Nye, 1984).

- (4) water transfer is described by Darcy's law, generalized to the unsaturated zone; soil hydraulic characteristics are deduced from pedotransfer functions (Clapp and Hornberger, 1978); ammoniacal N transfer is described by a convection-diffusion scheme (2) (Bear, 1972);



- volatilization is calculated with an advection model (3) (Itier and Perrier, 1976); it allows to account for local advection and makes the model suitable for field scale applications.

- evaporation and surface temperature are calculated by solving the energy balance of the soil surface (6) using Noilhan and Planton (1989) and Cellier *et al.* (1996) parameterizations.

The model uses readily available input data, including soil and slurry characteristics, hourly meteorological data, and technical informations. It was tested under agricultural conditions and the simulation was satisfactory for the global amount and the hourly variations.

Although pH is the most sensitive factor of the model, pH variations were ignored, and pH was taken constant for all simulations. Biophysical processes such as ammonification, nitrification, *etc.* were neglected (Génermont *et al.*, 1997).

## **2.2. Reference situation**

The reference data used for the simulations came from an experiment carried out at the INRA experimental station of Le Rheu, near Rennes (Brittany, France). 133 m<sup>3</sup> ha<sup>-1</sup> of cattle slurry for a total ammoniacal nitrogen supply of 114 kg N ha<sup>-1</sup> were applied on March 16, 1994 (day of year 75) over a 1.7 ha field, on a bare slightly acid (pH = 6.6) loam soil with water content at field capacity. The meteorological data were measured at the experimental site. For more details, see Génermont (1996). Simulations were performed for a 10 day period which allows to account for almost the total losses in most cases.

## **2.3. Simulations**

Simulations were performed by changing one single factor at a time by adding a coefficient to the reference value or by multiplying it. The imposed range of variation was chosen in accordance with literature recommendations and/or with reasonable agricultural practices. We calculated the cumulative losses for different times after spreading. The response of the model to a change in one factor was analyzed by using the ratio of the cumulative losses with this factor to the loss in the reference simulation. When quoted in the text, the reduction always refers to the loss obtained as % of the loss of the reference simulation.

### 3. Slurry properties modification

#### 3.1. Acidification

Initial slurry pH are generally rather basic (7-8.5), which favors ammonia volatilization. Slurry acidification is thus often recognized as an efficient mean to reduce volatilization.

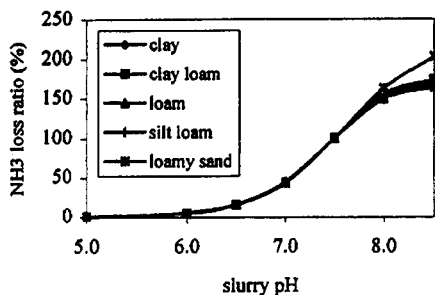

Figure 2

Simulated effect of slurry acidification on loss, for different soil types

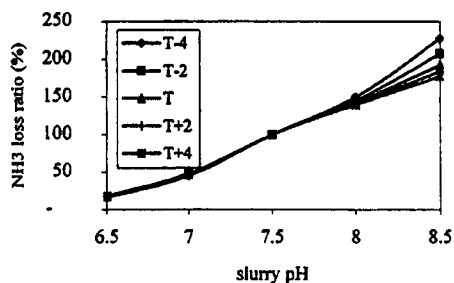

Figure 3

Simulated effect of slurry acidification on loss, for different temperatures

Simulations were performed for different soil types (Fig.2) and climatic conditions (Fig.3). They show that acidification was more efficient for a sandy soil (Fig.2), for which however losses were small (14-17%) compared to the other soils. It was also more efficient for alkaline slurries under cold conditions (Fig.3).

Simulations are in agreement with published results of field experiments. Volatilization calculated with pH 6 (resp. 6.5) was 12% (resp. 15%) of that with pH 7 (resp. 7.5) which was close to the observed reduction to 20% for a drop in pH from 7 to 6 by Stevens *et al.* (1989).

Jarvis and Pain (1990) recommended to bring the slurry pH down to 6 or 5. But bringing it to 5 is not worthy compared to bringing it down to 6 (Fig.2), because losses were almost zero for both pH. This is an interesting result, as acidification becomes more costly when pH decreases: 1 pH unit decrease needs 10 times more acidifying substance than the one before.

These results give an idea of the potential for lowering ammonia loss by acidification. However the effect of acidifying different slurries to similar pH values may be variable because emissions are also related to the slurry buffering capacity (Husted *et al.*, 1991).

### 3.2. Dilution

Stevens *et al.* (1992) observed that diluting the slurry decreased ammonia volatilization (Table 1). By simulating the same treatments, the model calculated smaller reduction in ammonia loss (Table 1), which may be linked to the differences in soil, slurry and climate.

	Stevens <i>et al.</i> , 1992	Model simulations	Comparison with washing	Model simulations
Dilution (% by volume of slurry)	Measured loss (% of loss without dilution)	Calculated loss (% of loss without dilution)	Corresponding volumes of water for washing	Calculated loss (% of loss without washing)
0	100%	100%	0.0 mm	100%
40	83%	88%	5.4 mm	63%
100	50%	73%	13.4 mm	31%
140	39%	63%	18.8 mm	24%

*Table 1*  
Comparing simulations of slurry dilution using the model to the results of Stevens *et al.* (1992) and to the effect of washing after application, using the same volumes of water (see below)

## 4. Application and post-application control techniques

### 4.1. Soil cultivation

Many publications refers to the influence of soil management on ammonia losses. The effect of the depth of incorporation was often studied. As slurry is incorporated into the soil, it is much less in contact with the atmosphere and the resistance to ammonia transport upward in the soil is large. As a consequence, several means of deep placement of ammoniacal N such as direct injections or incorporations just after application were proposed to the farmers, in order to reduce volatilization and to preserve the slurry fertilizing value. But observations in field conditions also evidenced that cultivation after application only resulted in the deep placement of a fraction of the slurry, the other fraction remaining at the surface. Simulations were made to evaluate the effect of partial incorporation by changing the placement of the slurry in the soil sub-model.

Simulations showed that the efficiency of the depth of incorporation highly depended on the proportion of slurry incorporated (Fig.4). Small depths were only efficient when at least 80% or almost all the slurry was incorporated (Fig.4 et 5), which corresponds to harrowing. When plowing with a rotavator, more slurry remains at the soil surface, and slurry should be incorporated at more than 10 cm deep in order to efficiently reduce ammonia losses.

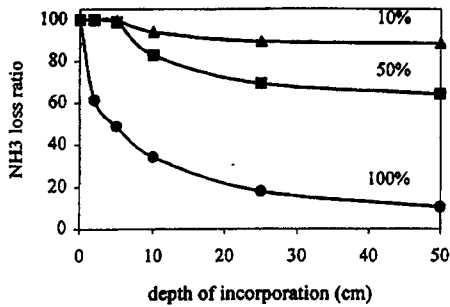

Figure 4

Effect of the depth of incorporation on loss, for three proportions of slurry incorporated

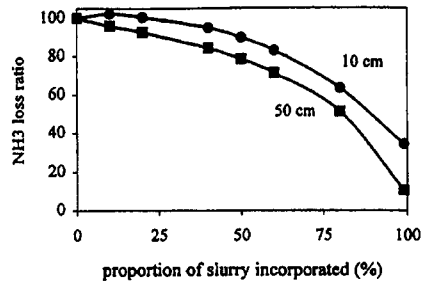

Figure 5

Effect of the proportion of the slurry incorporated on loss, for two incorporation depths

#### 4.2. Washing

Some authors also recommend to bring water after slurry, as it enhances ammoniacal N infiltration into the soil and dilutes ammoniacal N remaining at the soil surface.

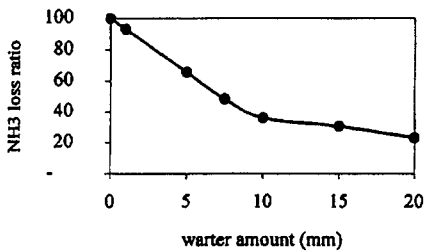

Figure 6

Simulated effect of washing after slurry application on ammonia volatilization

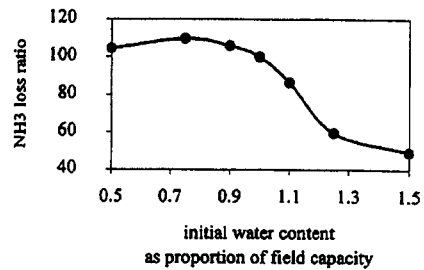

Figure 7

Effect of washing as a function of the soil initial water content

Simulations confirmed that losses were efficiently reduced, and showed that the optimal water amount is around 10 mm: with less water, losses were less reduced, but for greater amounts, reduction did not increase (Fig.6). Simulating a 10 mm irrigation immediately after slurry application, the influence on ammonia volatilization (36%) was similar to that measured by Moal *et al.* (1995) (32%), but was much less than that measured by Klarensbeek and Bruins (1991) (67%). This discrepancy could be explained by interactions with environmental conditions. For example, simulations with various initial soil water contents showed that washing was more efficient in this case for soils with high initial water contents. It is then interesting to compare the effect of either diluting the slurry before application, or bringing the same amount of water after the slurry has been spread. Results of simulations were reported on *Table 1*: washing after application appeared to be highly more efficient than slurry dilution before application. Then farmers, knowing

this kind of result, will be able to choose which strategy to adopt, as a function of their own equipment and agronomic constraints (dilution apparatus, time for application, trafficability, etc.).

### 4.3. Timing of agricultural techniques

Simulating plowing or washing at different dates after spreading evidenced that their timing is very important (Fig.8). In some cases, a delay of only several hours might ruin the effect of soil plowing. This is due to the fact that the rate of ammonia volatilization is directly related to the concentration of ammonia in solution: fluxes are high at the beginning of the volatilization period (1-2 days) and then decrease exponentially owing to the decrease in available ammoniacal N. The loss reduction was approximately exponentially inversely related to the delay between slurry application and plowing or washing. This confirmed and enlarged the results found by Sommer (1992): losses when the soil was harrowed just after application were 33% of those when it was harrowed only 8 hours after. As a consequence, the post-application control techniques must be brought into operation as quickly as possible if the farmer want them to be really effective, and even sometimes worthy.

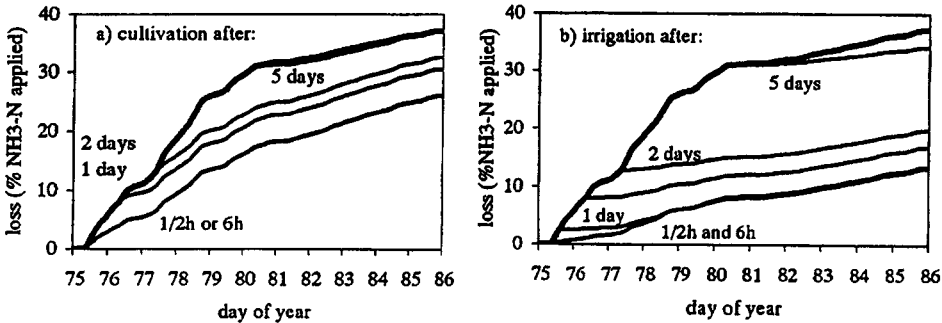

Figure 8  
 Simulated cumulative loss of ammonia volatilization after slurry spreading followed by a) incorporation or b) washing at different dates

## 5. Slurry management and agronomic strategies

### 5.1. Slurry application timing

National and regional legislations recommend or impose periods in the year for land disposal of slurry, mainly in order to reduce nitrate leaching. The choice of these periods is of great importance, as ammonia losses are weather-dependent. Generally, measures are set up so that slurry is spread under wet or/and cold climatic conditions, where ammonia losses are known to be small. The two factors that will be mainly affected by applying slurry at different dates are temperature and soil water content. Volatilization is high under warm conditions (Fig.9). The effect of soil water content is less clear: on the one hand, on a wet soil, the slurry

ammoniacal N is diluted, and emissions should be reduced; but on the other hand, infiltration is reduced, which should increase emissions. Simulations performed to investigate the effect of the initial soil water content on volatilization showed that losses were reduced for dry soils and even more for wet soils (Fig.10): in the first case, infiltration was the dominating factor influencing ammonia volatilization, and in the second case, ammoniacal N dilution was prevailing. Ammonia losses were really efficiently reduced for high initial water contents, compared to the soil water content at field capacity. But in practice, this conflicts with the need for good trafficability of the soil for spreading and even after for incorporation. As a consequence, the choice should rather be oriented by the temperature considerations, and not by the soil water content at the time of spreading. Unfortunately the timing of slurry applications then conflicts with the desire for good growing conditions to promote the efficient utilization of the slurry nutrients.

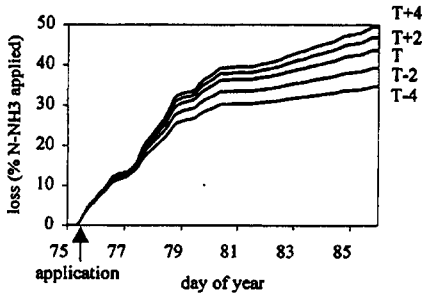

Figure 9

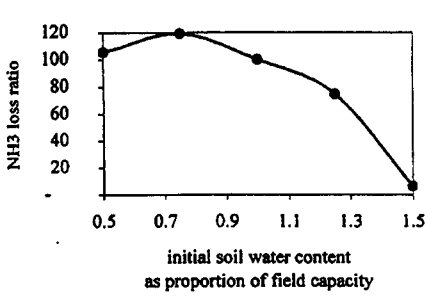

Figure 10

Using the model for studying the effect of temperature on ammonia volatilization

Using the model for studying the effect of initial soil water content on volatilization

The choice of the time in the day for spreading has also been discussed by Klarenbeek and Bruins (1991). Simulations showed that, losses during the first day were significantly reduced ( $\approx 60\%$ ) when slurry was applied during the night (9-12 p.m.). But the effect was very small when accounting for the total loss over the whole volatilization event (only 1-3 %).

**5.2. Slurry application at the farm scale**

Furthermore, the technical and strategic choices will have to be taken at the farm scale. The results of simulations for soils with various textures showed that total loss could highly differ. For example, losses for a sandy soil were 14-24% of those of loamy and/or silty soils, with the same pH. For farms with heterogeneous soils (texture, pH, cation exchange capacity, etc.), this implies that abatement techniques must be preferentially applied to soils with the higher potential for volatilization, than to the others.

## 6. Conclusion

This presentation showed how using a model could help evaluating and improving means and strategies used to reduce the N losses through ammonia volatilization after organic fertilization. By integrating explicitly factors related to climate, soil and slurry, this mechanistic model helps investigating more thoroughly the efficiency of such techniques. It therefore is a useful tool for improving the management of the agricultural and natural resources and for the protection of the environment.

Furthermore, the efficiency of such techniques strongly depends on the emission conditions. To justify the cost of advanced slurry pretreatment and application equipment for a farmer, they should really be efficient under all environmental conditions prevailing in the area. The further intensive use of this model would allow to more precisely identify for which type of agronomical, pedological and climatic conditions which kind of abatement technique will be the most efficient, and the right equipment to invest in. By coupling it with an economical model, it would then allow to stand out the cost efficiency of such measures. For example, slurry properties modifications have sometimes been recognized to be expensive compared to their efficiency. The combination of both models will help determining if they are to be efficient when it is not possible to cultivate the soil, on grass land or non-tillage systems for example.

## 7. References

- Bear, J.**, 1972. Dynamics of fluids in porous media. Elsevier. New York.
- Beutier, D., Renon, H.**, 1978. Representation of  $\text{NH}_3\text{-H}_2\text{S-H}_2\text{O}$ ,  $\text{NH}_3\text{-CO}_2\text{-H}_2\text{O}$ , and  $\text{NH}_3\text{-SO}_2\text{-H}_2\text{O}$  vapor-liquid equilibria. Ind. Eng. Chem. Process Des. Dev. 17. 220-230.
- Buijsman, E., Maas, F.M., Asman, W.A.H.**, 1987. Anthropogenic  $\text{NH}_3$  emissions in Europe. Atmos. Environ. 21. 1009-1022.
- Cellier, P., Richard, G., Robin, P.**, 1996. Partition of sensible heat fluxes into bare soil and the atmosphere. Agric. For. Meteorol. 82. 245-265.
- Clapp, R.B., Hornberger, G.M.**, 1978. Empirical equations for some soil hydraulic properties. Water Resour. Res. 14. 601-604.
- E.C.E.T.O.C.**, 1994. Ammonia emissions to air in Western Europe. Technical Report No. 62. 196p. ECETOC, Brussels.
- Frost, J.P.**, 1994. Effect of spreading method, application rate and dilution on ammonia volatilization from cattle slurry. Grass Forage Sci. 49. 391-400.

**Génermont S.**, 1996. Modélisation de la volatilisation d'ammoniac après épandage de lisier sur parcelle agricole. Thèse de Doctorat, Univ. Toulouse, INRA Bioclimatologie Grignon, 331p.

**Génermont S., Cellier P.**, 1997. A mechanistic model for estimating ammonia volatilization from slurry applied to bare soil. *Agric. For. Meteorol.*, 88, 145-167.

**Hauck R.D.**, 1983. Agronomic and technological approaches to minimizing gaseous nitrogen losses from croplands. In: *Gaseous loss of nitrogen from plant-soil systems.* (Eds. Freney, J.R. and Simpson, J.R.) 285-312. Martinus Nijhoff. The Hague, The Netherlands.

**Husted S., Jensen L.S., Jorgensen S.S.**, 1991. Reducing ammonia loss from cattle slurry by the use of acidifying additives: the role of the buffer system. *J. Sci. Food Agric.*, 57, 335-349.

**Itier B., Perrier A.**, 1976. Présentation d'une étude analytique de l'advection : I. Advection liée aux variations horizontales de concentration et de température. *Ann. Agron.* 27. 111-140.

**Jarvis S.C., Pain B.F.**, 1990. Ammonia volatilization from agricultural land. *Fert. Soc. Proc.* no. 298. 25p.

**Klarenbeek J.V., Bruins M.A.**, 1991. Ammonia emission after land spreading of animal slurries. Ammonia and odour from livestock production, V.C. Nielsen, J.H. Voorburg and P. L'Hermite (eds.), 107-115, Elsevier Applied Science, London.

**Moal J.F., Martinez J., Guiziou F., Coste C.-M.**, 1995. Ammonia volatilization following surface-applied pig and cattle slurry in France. *J. Agric. Sci.*, 125, 245-252.

**Noilhan J., Planton S.**, 1989. A simple parameterization of land surface processes for meteorological models. *Monthly Weather Rev.* 117. 536-549.

**Rachhpal-Singh, Nye P.H.**, 1984. Diffusion of urea, ammonium and soil alkalinity from surface applied urea. *J. Soil Sci.* 35. 529-538.

**Rachhpal-Singh, Nye P.H.**, 1986. A model of ammonia volatilization from applied urea. I. Development of the model. *J. Soil Sci.* 37. 9-20.

**Sommer S.G.**, 1992. Ammonia volatilization from cattle and pig slurry during storage and after application in the field. Ph. D. Thesis. Royal Veterinary and Agricultural University. Copenhagen, Sweden, 37p

**Sommer S.G., Hutchings N.**, 1995. Techniques and strategies for the reduction of ammonia emission from agriculture. *Water Air Soil Poll.*, 85, 237-248.



**Stevens R.J., Laughling R.J., Frost J.P., 1989.** Effect of acidification with sulfuric acid on the volatilization of ammonia from cow and pig slurries. *J. Agric. Sci., Cambridge*, 113, 389-395.

**Stevens R.J., Laughlin R.J., Frost J.P., 1992.** Effect of separation, dilution, washing and acidification on ammonia volatilization from surface-applied cattle slurry. *J. Agric. Sci.*, 119, 383-389.

**Van der Molen, J., Beljaars A.C.M., Chardon W.J., Jury W.A., van Faassen H.G., 1990.** Ammonia volatilization from arable land after application of cattle slurry. 2. Derivation of a transfer model. *Neth. J. Agric. Sci.* 38. 239-254.

**Chairman's summary of part 3.**  
**Measurement, modelling and control of gaseous emissions**  
**Sven SOMMER**

Animal manure, domestic waste, sewage sludge and the organic matter produced may be a source of atmospheric pollutants as well as beneficial for farmers using this organic materials as fertilisers. The gases of greater concern includes ammonia ( $\text{NH}_3$ ), nitrous oxide ( $\text{N}_2\text{O}$ ) and methane ( $\text{CH}_4$ ). Furthermore obnoxious gases may affect the use of organic waste as a source of plant nutrients.

Through the development of farm models one can identify the change in total emission of gases from the farm caused by a treatment in either the animal house, during storage and from manure application. Thus a treatment in one stage of the management system may affect emission in another stage. In conclusion a treatment should not :

- increased losses of the compound at another stage of the management;
- increase emission of another component.

Inventories at a farm, regional or at national level quantifies the relative importance of emission of different components in relation to other component but also in relation to different sources at the farm. Methane emission from animals is the most important agricultural sources of atmospheric methane, whereas nitrous oxide emission from solid manure in animal houses and during storage contributes significantly to  $\text{N}_2\text{O}$  in the atmosphere. In the field, all manures types and fertilisers causes emissions of  $\text{N}_2\text{O}$ .

Inventories of gaseous emission should encompass all stages of management. It was shown that dairy cattle collecting yards represents a significant source of  $\text{NH}_3$  and of some  $\text{N}_2\text{O}$ . A source which has not been included in earlier inventories of the emission of these gases.

A study of gaseous emissions of  $\text{NH}_3$ ,  $\text{CH}_4$  and  $\text{N}_2\text{O}$  from management of solid manure was presented. Showing that composting during storage causes higher emissions of  $\text{NH}_3$  and lower emissions of  $\text{N}_2\text{O}$  and  $\text{CH}_4$  than from anaerobic stored manure. In the field little was lost from composted manure compared to losses from anaerobic treated manure.

Field studies showed that ammonia emission from slurry are affected by pretreatment, anaerobic fermented slurry has a higher  $\text{NH}_3$  emission potential than untreated slurry.  $\text{NH}_3$  losses were not affected by additives. Application techniques may affect  $\text{NH}_3$  losses considerably. Ammonia emissions from application of slurry with different techniques may be ranked as follows: plough>rotary cultivation>harrowing. This ranking is not taking the lag phase between application and incorporation into consideration. The ploughing is time consuming compared to rotary harrowing and due to the greater lag time between application and ploughing more  $\text{NH}_3$  is lost than when rotary harrowing the slurry into the soil. A model which incorporates the effect of lag time into the calculation of losses was presented.

Modelling can give us a valuable insight in the effect of climate, soil and slurry characteristics and losses of ammonia from slurry applied to the field. Especially mechanistic models can provide knowledge about the interaction of these factors, application techniques and timing of application of slurry.

The farmer has a need of knowing the availability of nitrogen applied to the crop in organic waste and manure. Mineralisation of sludge were studied in the lab and data used to validate the model NCSOIL. It was shown that sludge treatment significantly affects mineralisation. For the purpose of developing decision support system characterisation of N availability through incubations and chemical analyses was used to develop a model. The model were validated with data from the field studies.

## **Part 4**

**Processing and handling of wastes.**

**Chairman : P. Derikx (Netherlands)**



# Processing strategies for organic wastes

*Stratégies de traitement des déchets organiques.*

## *Invited Paper*

**C H Burton**

Silsoe Research Institute, Wrest Park, Silsoe,  
MK45 4HS. Bedford. United Kingdom  
E-mail : colin.burton@bbsrc.ac.uk

## **Abstract**

*Treatment of organic wastes is often an essential part of the best management package to avoid pollution in many situations. Very dilute wastewaters may be released to water courses following rigorous treatments as typified by sewage purification processes. Otherwise, the disposal of most organic wastes continues to be land application. Where sufficient suitable land is not available, some form of processing is needed to reduce the strength of the waste in terms of its organic content (eg, BOD) and/or key nutrients (eg, nitrogen and phosphorus) and/or disease hazards.*

*Processes comprise one or more biological and physical stages; chemical additives may also be used. Biological degradation of organic matter has the general effect of breaking down the reactive organic chemicals which make up the BOD value and lead to offensive odours. Anaerobic treatment enables biogas collection but processing can be slow. Aerobic treatment of solid or liquid wastes is faster and exothermic enough to allow natural heating up to 60°C, but it is more expensive. The combination of such temperatures and oxygen destroys many pathogens especially strict anaerobes. Ammoniacal nitrogen can be removed as N<sub>2</sub> gas by nitrification followed by de-nitrification.*

*Physical processes include screening, centrifugation, sedimentation and filtration. They involve the separation of a solid phase and/or the production of a clarified wastewater. This often compliments the biological step as a great deal of the insoluble organic matter is not readily broken down. Furthermore, it enables the removal of a range of insoluble materials such as phosphates and heavy metals. This separation may be enhanced by the addition of lime or flocculants.*

*New processes for effluent treatment include membrane filtration, chemical electro floatation, incineration, heat treatment (sterilization) evaporation/drying, and ammonia stripping/recovery. Although effective, the high cost of some of these emerging technologies makes them less suitable for agriculture than for dealing with industrial effluent.*

## Résumé

Le traitement des déchets organiques constitue souvent une étape essentielle pour une gestion optimisée de ces produits sans risque pour l'environnement. Des effluents liquides très dilués peuvent être rejetés dans le milieu naturel après différents procédés de purification. Néanmoins la gestion des déchets organiques passe le plus souvent par l'épandage agricole. Lorsque les surfaces pour l'épandage sont limitées il est alors nécessaire de réduire la charge polluante de ces produits en termes de leur matière organique (DBO), et de leur teneur en éléments nutritifs (azote et phosphore) et/ou germes.

Les procédés comprennent souvent au moins une étape biologique et physique. Les additifs chimiques étant également parfois utilisés, le traitement anaérobie permet de produire du biogaz, mais la dégradation est lente. Le traitement aérobie des déchets liquides ou solides est plus rapide et exothermique, permettant une élévation naturelle de température jusqu'à 60°C. L'apport d'oxygène et le maintien de ces températures élevées permet également la destruction des germes pathogènes notamment les germes anaérobies stricts. L'azote ammoniacal peut être éliminé sous forme de  $N_2O$  par nitrification suivie d'une dénitrification.

Les procédés physiques comprennent le tamisage, la centrifugation, la sédimentation et la filtration. Ils impliquent la séparation d'une phase solide et/ou la production d'un effluent liquide clarifié. Ces étapes complètent les procédés biologiques et permettent notamment de séparer les composés insolubles tels que les phosphates et métaux lourds. Cette séparation peut être améliorée par l'ajout de chaux ou de flocculants.

Les nouveaux procédés pour le traitement des effluents comprennent la filtration sur membranes, la flottation électro-chimique, l'incinération et le traitement thermique (stérilisation), l'évaporation / séchage et le « stripping » de l'ammoniac.

Bien qu'efficaces, le coût élevé de ces technologies émergentes ne les rend pas nécessairement disponibles en agriculture, comparativement à leur utilisation développée en secteur industriel.

## 1. Introduction

The role of treatment in the management of organic wastes (eg, agricultural manures, sewage sludge and food processing effluent) is increasing. Such wastes can pose serious water and air pollution risks (eg, as reported by the NRA, 1995) as well causing offensive odours (eg, as reported by the IEHO, 1988); in some cases, they are also a hazard to public health. However, these same wastes can be a useful resource in the supply of plant nutrients or a feedstock to a composting system or a biogas plant.

Good management practice has been advocated for farm wastes for many years such as presented in MAFF codes (1991 and 1992). This includes adequate storage facilities and controlled applications to fields taking into consideration loading and seasonal constraints; a similar approach is common in many parts of Europe (Parfait et al, 1996). These same methods have been used with other organic wastes that are also disposed of by landspreading (eg, sewage sludge). However, applications in excess of the capacity of the local environment can only end up as pollution of one sort or another. Furthermore, even if there is enough local land with a theoretical capacity to receive the applied manure, the related pollution problems may still not be eliminated due to a range of other factors such as a hilly terrain or the close proximity of streams or boreholes. In these cases, and where there is insufficient land or where the waste poses special hazards such as disease risks, some form of treatment will be required as part of the solution.

## 2. Processing strategies

A large number of treatment processes now exist for tackling these problems some of which have already been reviewed especially with respect to agriculture (Burton, 1992 and 1996). However, evaluating their effectiveness can easily be muddled by the interpretation of the very word *treatment*. Colloquially, this word can become very imprecise and it can be relegated to implying that no more than *something* has been done to the waste by the process; but what this amounts to is often not clear. The remedy for this situation must be the focusing on the *purpose* of the treatment rather than how it is done. For example, it is not the practice of bubbling air through pig slurry that brings about any benefit, but the subsequent measured odour abatement or reduction in organic matter. There is a need to identify and set unambiguous targets for the treatment process. In this way (a), any given process can be scored as inadequate, successful or, in some cases, excessive and (b), objective comparisons between different processes become possible - the most cost effective package can thus be identified.

Thus the starting point in dealing with an organic waste stream should be the clear definition of what the problem is (eg, odour nuisance, excess nitrogen, water pollution). This will depend on the intended disposal route (eg, to farm land, to a water course, for re-use). The second step is setting the treatment target required to resolve this problem (eg, a 50% reduction in the BOD<sub>5</sub>, removal of 90% of ammoniacal nitrogen). Such targets can be set even for the subjective area of odour abatement (Williams, 1984; Pain et al, 1990). Only when the purpose of treatment is clear should the various methods and equipment be considered. Figure 1 summarizes many of the current scenarios starting with the intended disposal route, identifying the likely requirements and lastly considering possible processes.



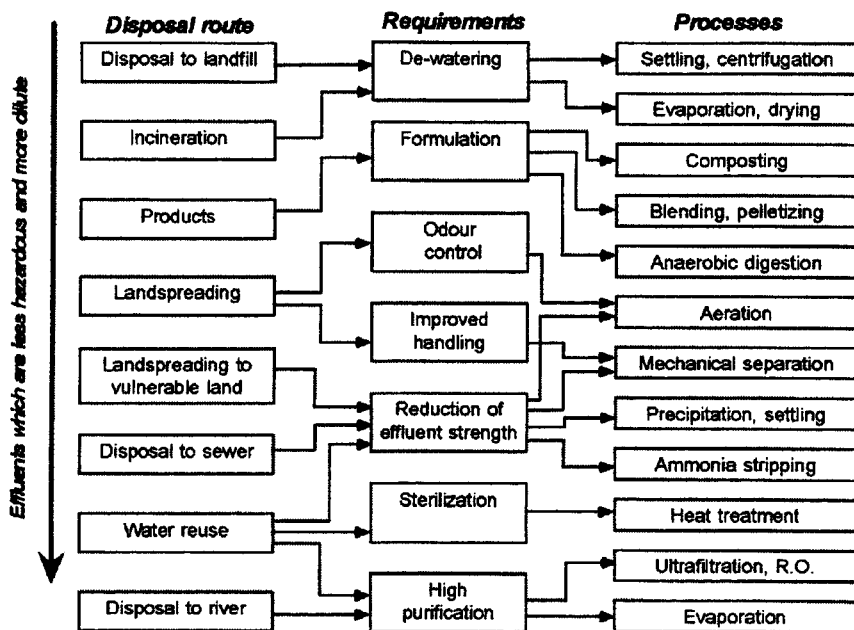

Figure 1.

*Treatment strategies: process options depend greatly on the type of effluent and proposed use or disposal route.*

A system that works (ie, that fulfils the requirements) may turn out not be a realistic option owing to cost or some other factor. A cheaper and less effective option may still be considered but only if this is an acceptable compromise. The danger in the use of inadequate treatments though is that they can present the operator with a cost without fully resolving the underlying problem.

### 3. Physical processes

#### 3.1. Mixing

Mixing of tank contents is a key part of any process although it doesn't in itself impart any change to the average effluent composition. It provides a homogeneous feed to subsequent stages enabling a steady operation of what is often a continuous process producing a consistent treatment. Variations in the effluent can result from the natural separation of the suspended matter either into a floating layer or a settled sludge. The composition of effluents entering a treatment plant can be normally expected to vary as a result of many factors such as the periodic washing routines. Maintaining a steady feed to the treatment plant requires large feed tanks to provide buffering and again mixing is necessary.

A great deal of research has gone into mixing theory and equipment and many reviews have been produced (eg Cumby, 1990). Common weaknesses include inadequate power input (a minimum of 10W/m<sup>3</sup> is recommended - Cumby, 1987a) and poor selection and location of equipment especially in large stores.

### 3.2. Mechanical screening

Screening is a simple way of removing the coarse matter from effluents and thus greatly improving its ease of handling. If large quantities are present such as in livestock manures then the separated fibre can be useful in subsequent composting processes. In this case, it is important to ensure a high solids concentration in the separated fibre (ie 25%+) which leads to the selection of the more elaborate equipment such as screw and belt presses. However, if the main purpose of the operation is the removal of relatively small quantities of coarse matter (eg to protect equipment) then simpler screens will suffice. These have the advantage of higher throughput but a wetter fibre product is produced.

	Screen (drum)	Screw press	Decanter centrifuge	Laboratory centrifuge
	Burton et al, (1997)			Martinez et al, (1995)
% removal of :-				
TS (total solids)	41	42	61	76
N-Kj (Kjeldahl N)	17	17	30	-
P (phosphorus)	18	20	65	-
K (potassium)	17	12	12	16
Cu (copper)	-	-	-	82
Volume of concentrate (%)	17	15	21	13

Table 1

*Performance of three types of separating systems in terms of the removal of specific components from pig slurries into a concentrated stream. Values from a laboratory centrifuge test (10,000g for 30 minutes) are given for comparison.*

### 3.3 Separation and clarification

A more rigorous clarification of wastewater effluents is based on settlement. This can be by natural gravitation or enhanced by the use of flocculants and/or centrifugation. Gravity settling works best with dilute effluents (TS below 25 kg/m<sup>3</sup>) due to the production of large volumes of sludge with increased dry matter (Martinez et al, 1995). Centrifugation can produce concentrated sludges and a high degree of clarification but equipment is expensive and throughput modest. In either case, separation is more complete than simple screening as finer particles are included in the removed sludge layer. This extends to a more effective removal of some of the specific components of the effluent as shown in table 1. Whereas the screen and screw press only make a significant difference (ie, removal in excess of

the concentrate volume) to the TS, the decanter centrifuge also removes Kjeldahl nitrogen and phosphorus. The laboratory test indicates the maximum extent of physical separation which can also include certain metals but not the highly soluble potassium.

## 4. Biological processes

### 4.1 The oxidation process

Adequate aeration involves dissolving enough oxygen into liquid manure in order to replace an anaerobic system (chemically reducing) with an aerobic environment for microbial activity. As a result, organic matter, characterized by BOD<sub>5</sub> (biological oxygen demand), is rapidly oxidized to relatively harmless products such as carbon dioxide and water. The removal of the same material also takes away the main cause of the offensive odours associated with organic effluents and many pathogens that are strict anaerobes are destroyed. Under certain conditions (eg, treatment times of 3+ days and a dissolved oxygen concentration above 1ppm) nitrification of ammonia to nitrites and nitrates can occur with nitrogen release (as N<sub>2</sub>) in the subsequent de-nitrification, although the pollutant gas, nitrous oxide (N<sub>2</sub>O) can also be produced as an unwanted bi-product (Burton et al, 1993).

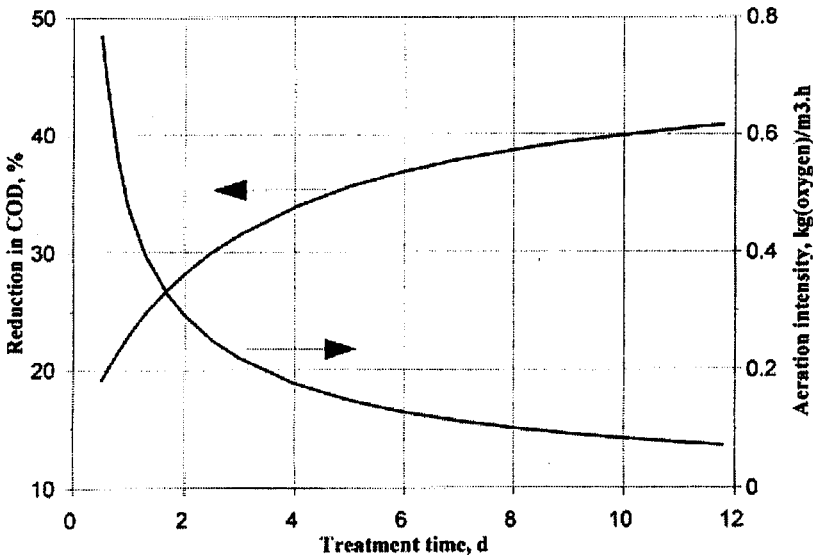
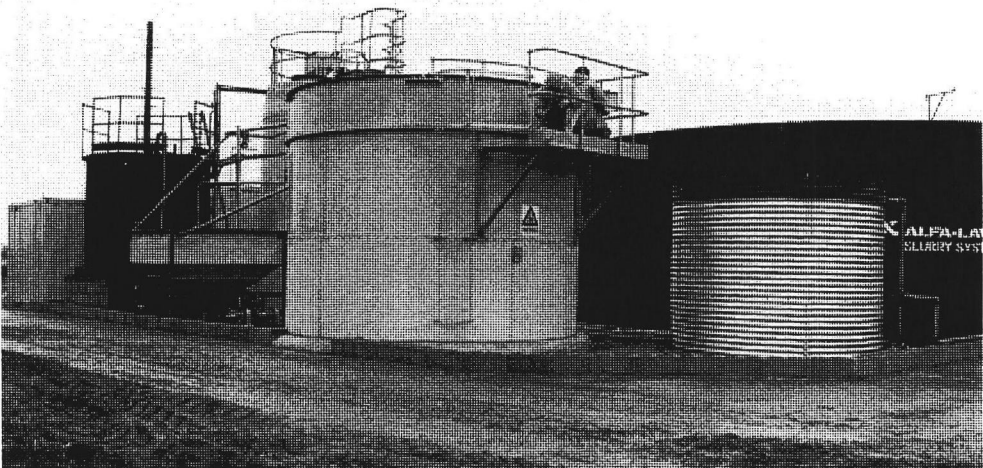

*Figure 2.*  
*Required aeration intensity compared to COD breakdown achieved.*  
*Longer treatments enable more gentle and efficient aerobic treatment.*  
*(Evans et al, 1983; Burton & Farrent, 1998).*

## 4.2 Aerobic treatment

Continuous aerobic treatment is nutrient-limited and is thus independent of both temperature and aeration level within limits. In the case of temperature, activity should be kept within the mesophilic range (ie 15 to 45°C); at higher temperatures thermophilic activity takes over leading to poorer performance (Burton et al, 1995). Unless nitrification is desired, the aeration level is not critical so long as enough oxygen is supplied to meet the demand. For all but the most dilute effluents this still implies large volumes of air based on anticipated reduction of the organic load expressed as COD or chemical oxygen demand (Figure 2). Short treatments have the additional problem of requiring a high *intensity* of aeration ie the hourly oxygen requirement per unit volume; this tends to rule out the more efficient but gentle bubble type diffuser type aerators.

Aeration systems are commonplace at sewage treatment works and some experimental units are also being used for treating stronger effluents such as farm slurries (figure 3). Trials with this system using pig slurry revealed degradation of 93% of the ammoniacal nitrogen, 67% of the Kjeldahl nitrogen, 43% of the COD content but only 8% of the total dry matter (Burton et al, 1998). The implication is that aeration only removes the reactive part of the organic matter leaving much of the inert material (including the suspended matter) unaffected.



*Figure 3.*  
*Farm scale treatment plant for aerating piggery slurry and typical performance values (Burton & Farrent, 1998).*

Although effective for certain duties including odour abatement and nitrogen removal, aeration is not a universal solution to all effluent problems.

Batch aeration is straightforward and sometimes preferred for dealing with small effluent volumes; it is also relatively cheap to install in existing storage tanks or lagoons. However, it can result in control problems due to the variable load and the treatment tends to be inconsistent. A compromise might be sequential batch processing (Lo et al, 1990) which can also incorporate a settling stage.

### **4.3 Composting**

The principles of composting solid organic wastes follow closely those of the aerobic treatment of wastewaters. It is essentially an aerobic process in which the more reactive organic components are broken down leaving a stabilized mass. Adequate oxygen must again be supplied either by regular agitation or forced aeration if anaerobic conditions are not to develop. In addition, the structure of the solid needs to be open and dry matter content should be around 250 kg/m<sup>3</sup>. An important feature of a successful process is the rise in temperature of the solids as the result of the exothermic activity. Ideally this should exceed 60°C thus both destroying pathogens and any weed seeds. The fate of the ammoniacal nitrogen depends on the C:N ratio in the solid mass; the higher the level of carbon, the more retention can be expected. Losses fall to zero for very high levels of carbon (C:N ratios over 60:1) but the fertilizer value is then much lower (Cshej et al, 1996).

### **4.4 Anaerobic digestion**

In the absence of oxygen, microbial activity continues anaerobically. The process is slower but reactive organic matter is again broken down thus leading to a reduction in the BOD<sub>5</sub> value and biogas can be produced as a bonus. In the simplest form of an anaerobic lagoon system, such gas is not collected and the main benefit of the approach is a reduction of organic load plus the removal of some phosphate along with other insoluble matter if settlement is encouraged. However, even if unwanted, the free emission of methane is generally unacceptable and some form of gas collection is needed. The gas is in fact an important bi-product in most cases and the design of digesters to maximize yield is important. This involves agitation and the maintenance of temperatures in the range 30 to 40°C. The performance of digesters varies widely reflecting the feed material as much as the design but the example described by Montuelle et al (1992) summarizes the main features: reductions in BOD<sub>5</sub> and COD were reported as 84 and 58% respectively. There was no significant effect reported on the nitrogen (including ammonia) and phosphorus components as might be expected as there is no obvious removal route. Anaerobic digestion can have the benefit of odour abatement in that many of the organic chemicals implied are broken down and some pathogens can be destroyed in the digester environment but the reduction is less than for aerobic systems.

## 5. Chemical treatment

A range of specific chemicals already feature in currently available treatment technologies including acids, flocculants and precipitants (Burton et al, 1997). The addition of strong acids to livestock manures has been explored as a method to cut ammonia losses by reducing the pH. Although an effective abatement measure, the hazards and cost of the method make it unattractive. The use of various flocculants in conjunction with a clarification step is common in many areas of effluent treatment although the performance can be variable. Many of the agents work on the basis of introducing strong ions (eg ferric or  $\text{Fe}^{3+}$ ) into the effluent to break down the colloidal system; their contribution is less pronounced in concentrated effluents or where good settlement naturally occurs such as after aerobic treatment (Martinez et al, 1995).

The addition of a precipitant such as lime can also enhance clarification but the main purpose is to increase insolubility of the phosphorus and some of the metals. The method is effective but the quantities required can be large (30kg+ per tonne of effluent) and ammonia emissions can be increased. Ammonia is incorporated in the precipitate along with magnesium and phosphate in the MAP process used with livestock slurries. However, the MAP complex (magnesium-ammonium-phosphate) follows a precise stoichiometry requiring additional magnesium and phosphate to be added.

There is also a wide range of additives on the market offered for many purposes including breaking down of organic material, reduction in ammonia emission and odour abatement. The way that such additives [allegedly] work is not always clear but mechanisms include providing enzymes, bacteria cultures or entrapment. Many of these products remain unproven and due to a lack of information, it can be difficult to decide which, if any, should be used.

## 6. New processes

### 6.1 Thermal treatments

The use of heat as a part of a treatment process is already well established such as in the case of some aerobic and anaerobic systems. The primary aim though has been to sustain the process and, in some cases, to extract heat as well (Evans et al, 1982; Hemmersbach et al, 1985); temperatures above 50°C have rarely been needed. Heat is also effective for destroying pathogens which is a requirement in some specialised effluent treatments (Turner et al, 1997) but consistently high temperatures are needed to ensure a sufficient degree of pathogen inactivation. Where such sterilization is essential (eg, to combat a high disease risk) the related higher energy costs may be tolerated but otherwise they can be prohibitive for the more general treatment of wastewaters. Nonetheless, interest in this approach

continues to grow with the emergence of well developed systems such as the Sirven process (Veil, 1994). Energy efficiency (eg, heat recovery) will be the key to the uptake of such technology.

For the more hazardous wastes incineration may well be stipulated. However, the approach may also be used more generally for solid wastes with the motivation of energy generation. The commercial burning of chicken manure has already been established in the UK and other wastes are being considered (Burton et al, 1997). However, a high dry matter content (25%+) is essential if there is to be a net generation of energy. For the purpose of disposal alone, small quantities of wastes with a higher moisture can be incinerated if blended with solids, otherwise the process must be supported with conventional fuels such as oil or gas.

## **6.2 Filtration**

Filtration processes are subject to similar limitations to physical separation processes in that they affect mostly the insoluble components. However the specific options emerging each offer additional treatment potential. In the case of soil filters for example, there is also a biological factor leading to a breakdown of the dissolved organic material as well. This principle is used in the Solepur process for the total treatment of pig slurries (Martinez, 1997). Recognizing the limitation of soil filters in that they can generate a nitrate rich leachate, this process includes the collection and separate de-nitrification of such water before it is finally irrigated to land.

The use of membranes allows the physical removal of some of the dissolved materials from the wastewater. The extent of the filtration is a function of the membrane: the more open ultrafiltration type (UF) will only retain the larger molecules whereas the highest quality reverse osmosis type (RO) can lead to a virtually pure water stream. The application to wastewater treatment is limited though due to the high cost of the equipment and the relatively low throughputs. There may be a role for the treatment of very dilute effluent prior to disposal to the water course or to enable its reuse.

Treatment by electro floatation is linked with the use of flocculants in clarification and thickening steps in a process to produce a treated effluent and sludge. The electro floatation unit itself enhances flocculation and probably removes some of the dissolved matter also by precipitation. Its general suitability for wastewater treatment remains unproven at present.

### **6.3 Ammonia stripping**

The natural tendency of ammonia to volatilize from alkaline solutions is used as the basis of ammonia stripping as a treatment process. Lime can be added to raise the pH and ammonia is stripped by air/steam; it is subsequently recovered by scrubbing the effluent gases with sulphuric acid to produce a solution of ammonium sulphate. The approach is effective as a treatment but its viability will require there to be some value to the fertilizer solution produced.

### **6.4 Evaporation and drying**

Evaporation can offer a means of producing a useful concentrate from the effluent as well as leading to a heat-treated condensate for disposal. It has limitations though, including the need for an energy efficient operation which itself can result in very elaborate plant. Some de-watering of dilute effluents may be required and further treatment of the condensate may be necessary as it will invariably include a high proportion of the volatiles. The economics and technical demands of this treatment approach will limit its application although it will be an important first step if drying is intended.

The production of a dry stable product from waste concentrates has many attractions. Storage and transport is greatly improved and there is the opportunity for marketing a serious organic product as an alternative to inorganic fertilizers. Revenue from sales may or may not pay for the process but it will at least defray the overall treatment cost to an approach that has considerable environmental credibility in terms of nutrient re-use. Schemes have been piloted for sewage sludge processing (Boniface, 1990) and for animal manures. Blending is important with the addition of deficient components to provide a balanced fertilizer. Processing is very elaborate though and requires a dedicated operator who will probably manage a variety of effluents from different sources. Location and transport costs could become key factors.

For certain hazardous wastes (eg, sewage sludges containing high concentrations of heavy metals), drying prior to landfill may be required as the only acceptable disposal route. The drying process itself then is for the purpose of ensuring product stability in terms of mobility.



Process	Effect of treatment on the reduction of:							
	TSS	BOD <sub>5</sub>	Odour	Kj-N	Am-N	P	K	Pathogens
Mechanical screening	+	?	?	?	?	?	?	?
Sedimentation	++	?	?	+	?	+	?	?
Precipitation (lime)	+	?	?	?	!!	++	?	?
Composting	?	++	++	+	?	+	?	+
Aeration*	?	++	++	+	++	?	?	+
Thermophilic aeration	?	+	++	?	!!	?	?	++
Anaerobic lagoon	+	+	!!	?	?	+	?	+
Anaerobic digestion	?	++	+	?	?	?	?	+
Acidification	?	?	?	?	++	?	?	?
Ammonia stripping	?	?	?	+	++	?	?	+
Additives	?	?	+	?	?	?	?	?
Evaporation & drying	++	+	+	+	?	++	?	++
Reverse osmosis	+	+	?	?	+	++	+	+

*Table 2.*

*The relative contributions of the main treatments in the abatement of specific effluent components.*

Key: ++ large effect; + some benefit; ? little or no benefit; !! Possible negative effect. \* Including nitrification and denitrification

## 7. Conclusions

Poor management of organic effluent from the livestock, sewage and food industries can lead to a range of pollution problems including water contamination (by nitrates, phosphates and organic matter) air emissions (including ammonia, nitrous oxide and methane) and soil residues (including phosphates and heavy metals). There are also disease risks. Although not strictly an environmental pollution, the issue of odour nuisance is sometimes a major factor owing to the pressure of public complaints.

It is important to set unambiguous targets for treatment processes to enable both the verification of satisfactory performance and objective comparisons with alternatives.

A range of treatments for organic effluents which can tackle many of the problems identified are already available. These include aeration (e.g., odour, water and air pollution abatement), anaerobic digestion and lagooning (e.g., biogas production, odour abatement, reduction in BOD), separation (e.g., easier handling, reduction in TS) and composting (e.g., formation of a fertilizer product). Some treatment systems remain unproven as effective and/or cheap enough for the intended application.

There are also a range of new processes that may contribute towards effective treatment in the future. These include thermal treatments, purification by soil, use of chemical additives and membrane processes.

The suitability of these processes will depend both on the effluent composition and the criteria of treatment. The latter will be influenced by the intended disposal route. Table 2 summarizes the effectiveness of the main treatment options.

## 8. References

**BONIFACE, A.** (1990) Turning sewage sludge into soil. *The Chemical Engineer* 1990. 479: 16-17.

**BURTON, C.H.** (1992) A review of the strategies in the aerobic treatment of pig slurry: purpose, theory and method. *Journal of Agricultural Engineering Research* 54 248-271.

**BURTON, C.H.; SNEATH, R.W.; FARRENT, J.F.** (1993) The effects of continuous aerobic treatments on the fate of the nitrogen component in piggery slurry. *Proceedings of the International Congress on Nitrogen Flow in Pig Production and Environmental Consequences*, Wageningen 8-11 June 1993.

**BURTON, C.H.; FARRENT, J.W.** (1995) Evaluation of thermophilic aerobic treatment as a pollution abatement process. *Proceedings of the Sixth ISAFPW*, Chicago, USA, June 1995.

**BURTON, C.H.** (1996) An overview of the problems of livestock manure in the EU and the methods of dealing with it. *Proceedings of the Manure Management Symposium*, March 20-21, 1996, Winnipeg, Canada. p27-38.

**BURTON, C.H. BECK, J.; BLOXHAM, P.F.; DERIKX, P.J.L.; MARTINEZ, J.** (eds) (1997) *Manure management - treatment strategies for sustainable agriculture*. Silsoe Research Institute, Wrest Park, Silsoe, Bedford 1997.

**BURTON, C.H.; FARRENT, J.W.** (1998) Continuous aerobic treatment of pig slurry; evaluation of the long treatment time and two stage process options. *Journal of Agricultural Engineering Research* (in press).

**CUMBY, T.R.** (1987a) A review of slurry aeration: 2. Mixing and foam control. *Journal of Agricultural Engineering Research* 1987 36 157-174.

**CUMBY, T.R.** (1987b) A review of slurry aeration. 3. Performance of aerators. *Journal of Agricultural Engineering Research* 1987 36 175-206.

**CUMBY, T.R.** (1990) Slurry mixing with impellers: part 1, theory and previous research. *Journal of Agricultural Engineering Research* 1990 45 157-173.

**CSEHI, K.; BECK, J.; JUNGLUTH, T.** (1996) Ammonia emissions during composting of separated solids from liquid manure - Investigation about compost quality. Ag Eng Conference paper 96E-011, Madrid, Spain.

**EVANS, M.R.; DEANS, E.A.; HISSETT, R.; SMITH, M.P.W.; SVOBODA, I.F.; THACKER, F.E.** (1983) The effect of temperature and residence time on aerobic treatment of piggery slurry - degradation of carbonaceous compounds. *Agricultural Wastes* 1983 5 25-36.

**EVANS, M.R.; SVOBODA, I.F.; BAINES, S.** (1982) Heat from aerobic treatment of piggery slurry. *Journal of Agricultural Engineering Research* 1982 27 45-50.

**HEMMERSBACH, W.A.; SIMONS, D.; HEEGE, H.J.** (1985) Wärmeproduktion und Wärmenutzung bei der Flüssigmistbelüftung (Heat production and heat utilisation in slurry aeration). *Landtechnik* 1985 40 (7/8) 330-332.

**IEHO** (1988) Annual Report 87/88. The Institution of Environmental Health Officers, Chadwick House, Rushworth St. London S.E.1.

**LO, K.V.; LIAO, P.H.; VAN- KLEECK, R.J.** (1990) Aerobic sequencing batch reactor treatment for swine wastewater. *Proceedings of the Sixth International Symposium on Agricultural and Food Processing Wastes*, Chicago, USA, Dec 1990, 348-352.

**MARTINEZ, J.** (1997) Solepur: a soil treatment process for pig slurry with subsequent denitrification of drainage water. *Journal of Agricultural Engineering Research* 1997 66 51-62.

**MARTINEZ, J.; BURTON, C.H.; SNEATH, R.W.; FARRENT, J.W.** (1995) A study of the potential contribution of sedimentation to aerobic treatment processes for pig slurry. *Jor of Ag. Eng. Res.* 1995 61 87-96.

**MINISTRY OF AGRICULTURE, FISHERIES AND FOOD** (1991) - Welsh Office Agriculture Department. Code of Good Agricultural Practice for the protection of water. July 1991.

**MINISTRY OF AGRICULTURE, FISHERIES AND FOOD** (1992) - Welsh Office Agriculture Department. Code of Good Agricultural Practice for the protection of air. 1992.

**MONTUELLE, B; COILLARD, J; LE HY, J. B.** (1992) A combined anaerobic-aerobic process for the co-treatment of effluents from a piggery and cheese factory. *Journal of Agricultural Engineering Research* 51 91-100.

**NATIONAL RIVERS AUTHORITY** (1995) Water pollution from farm waste 1994. Water Quality Series No. 25. HMSO London July 1995.

**PAIN, B.F.; PHILLIPS, V.R.; CLARKSON, C.R.; MISSELBROOK, T.H.; REES, Y.J.; FARRENT, J. W.** (1990). Odour and ammonia emissions following the spreading of aerobically treated pig slurry on grassland. *Biological Wastes* 1990 **34** 149-160.

**PARFAIT, G.; MARTINEZ, J.; BURTON, C.H.** (eds) (1996) *Animal Manures and Environment in Europe*. (In French and English) Ingénieries EAT, Cemagref, Antony, Paris) Dec 1996.

**TURNER, C.; BURTON, C.H.** (1997) The inactivation of viruses in pig slurries: a review. *Bioresource Technology*. 1997. **61** 9-20.

**VEIL, L.** (1994) Procédé Sirven: la longue marche en avant. (The Sirven process: the long road ahead). *Porc Magazine* n°.270 Septembre 1994.

**WILLIAMS, A.G.** (1984) Indicators of piggery slurry odour offensiveness. *Agricultural Wastes* 1984 **10** 15-36.

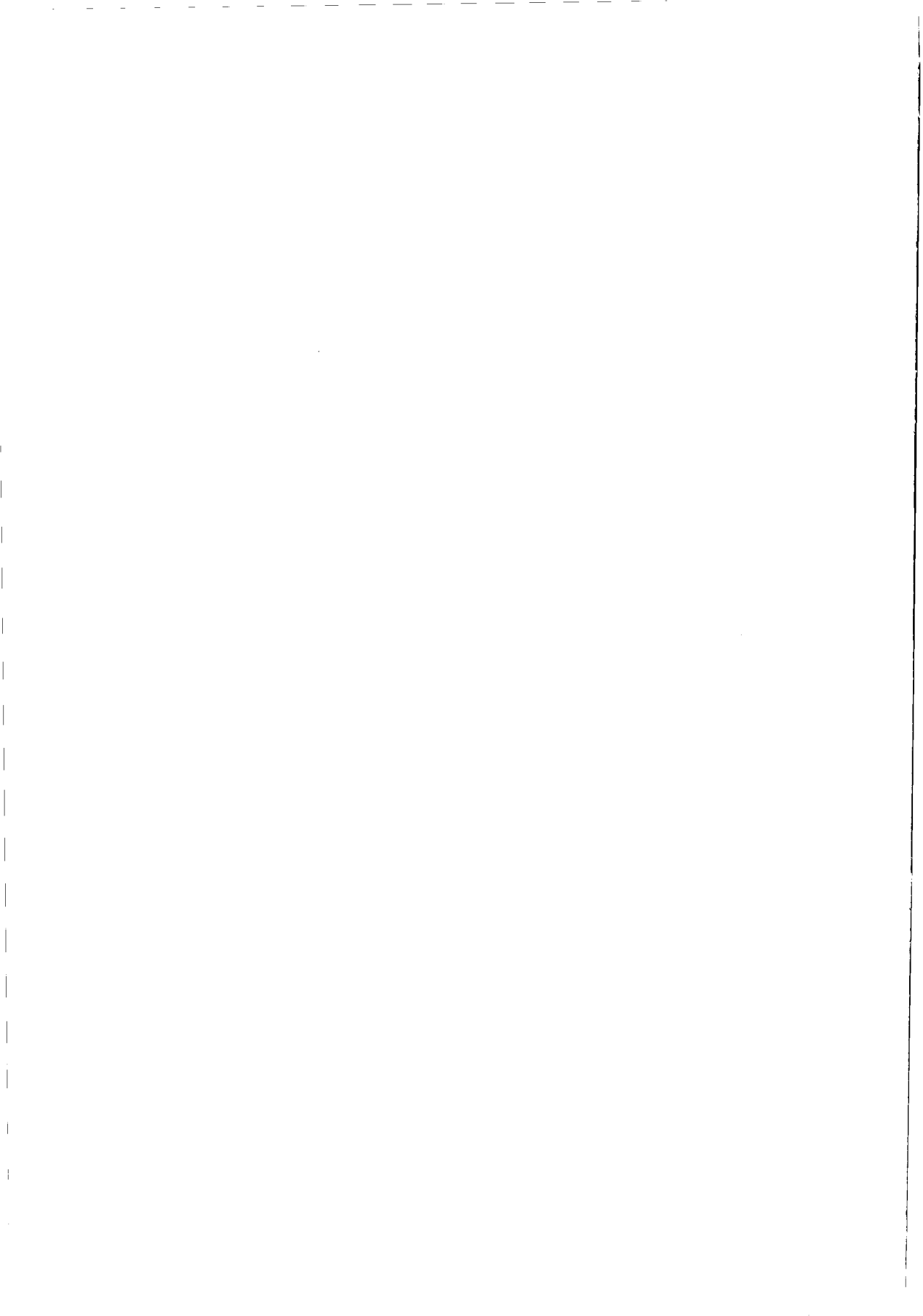

## The effect of continuous and intermittent aerobic treatment of pig slurry on nitrous oxide emissions.

*L'influence de l'aération continue et séquentielle sur les émissions de protoxyde d'azote au cours du traitement aérobie du lisier de porc.*

**Béline F., Martinez J.**

Cemagref, Livestock and Municipal Waste Management Division  
17 avenue de Cucillé, CS 64427, 35044 Rennes Cedex, France.  
E-mail: [fabrice.beline@cemagref.fr](mailto:fabrice.beline@cemagref.fr)

### Abstract

A laboratory treatment system was designed to study the fate of nitrogen during aerobic treatment of pig slurry. Different aeration processes, continuous and intermittent, were evaluated. For each of the four runs evaluated, the nitrogen mass balance was determined including measurement of the gaseous nitrogen forms (ammonia and nitrous oxide). For continuous aeration, nitrogen removal could rise up to 95% of the total ammoniacal content of the raw slurry (redox control = 0 mV<sub>Ag/AgCl</sub>) but was less important (45.7%) with redox potential control = -50 mV<sub>Ag/AgCl</sub> due to oxygen limitation for ammonium oxidation. Concurrently, intermittent aeration with aeration sequences of 9 and 15 hours/day led to a nitrogen removal of about 82% of total ammoniacal nitrogen content of the raw slurry. Between 30-33% of total ammoniacal nitrogen content of the raw slurry was emitted as N<sub>2</sub>O during continuous aeration while N<sub>2</sub>O emissions could be reduced from 30% of the total ammoniacal nitrogen content of the raw slurry during intermittent aeration (aeration: 2.5 hours, anoxic: 1.5 hours) to 0 using anoxic period longer (aeration: 1.5 hours, anoxic: 2.5 hours).

### Résumé

Un pilote de laboratoire a été développé afin d'étudier le devenir de l'azote au cours du traitement aérobie du lisier. Différents procédés aérobies, l'aération en continu et l'aération séquentielle, ont été évalués. Pour chacune des 4 séquences testées, un bilan azoté incluant la mesure des formes azotées gazeuses (ammoniac et protoxyde d'azote) a été effectué. L'aération continue a permis d'obtenir une élimination d'azote de l'ordre de 95% de l'azote ammoniacal du lisier brut (contrôle rédox = 0 mV<sub>Ag/AgCl</sub>). L'élimination a été moins importante avec un contrôle rédox = -50 mV<sub>Ag/AgCl</sub> à cause de la limitation en oxygène pour la nitrification. L'aération séquentielle, avec des séquences d'aération de 9 à 15 heures par jour, a permis une élimination d'azote d'environ 82% de l'azote ammoniacal du lisier brut. Environ 30-33% de l'azote ammoniacal du lisier brut a été émis sous forme de N<sub>2</sub>O pendant

l'aération continue tandis que les émissions de N<sub>2</sub>O ont pu être réduites, pendant l'aération séquentielle, de 30% (aération: 2.5 hours, anoxie: 1.5 hours) à 0% en utilisant des périodes anoxiques plus longues (aération: 1.5 hours, anoxie: 2.5 hours).

## 1. Introduction

Aerobic treatment of pig slurry is a source of losses of nitrogen as nitrous oxide (N<sub>2</sub>O). N<sub>2</sub>O is an important greenhouse gas contributing 260 times more than carbon dioxide on a weight bases<sup>1</sup> and is also implicated in ozone destruction<sup>2</sup>. Anthropogenic N<sub>2</sub>O emissions from cultivated soils, waste treatment, industrials processes, ... contribute largely to the increase of atmospheric concentration estimated at a rate of 0.2-0.3% per year<sup>1</sup>.

Burton *et al.*<sup>3</sup> and Willers *et al.*<sup>4</sup> observed N<sub>2</sub>O emissions during treatment of pig slurry up to 13% of the total nitrogen content of the raw slurry. Also, the increasing of aerobic treatment farm scale units could result in an increasing of N<sub>2</sub>O emissions. Nevertheless, Osada *et al.*<sup>5</sup> indicated that it is possible to reduce N<sub>2</sub>O emissions during aerobic treatment using intermittent aeration. Indeed, they observed N<sub>2</sub>O emissions of about 35% of the total nitrogen content of the influent using continuous aeration and sequential feeding (daily) whereas N<sub>2</sub>O emissions represented less than 1% using intermittent aeration.

This paper compares the N<sub>2</sub>O emissions from continuous and intermittent aeration of pig slurry in order to determine possible conditions of nitrogen removal without N<sub>2</sub>O emissions.

## 2. Methods and Procedures

### 2.1. The slurry

Pig slurry was collected from an experimental farm in Brittany (Caulnes, 22). The runs were carried out on the liquid fraction of handled separated (0.63 mm) slurry. The slurry composition varied between runs but was consistent through the duration of each. Its mean composition is given on table 1.

Runs	TN mgN/kg	TAN mgN/kg	TS g/kg	TSS g/kg	VSS g/kg
1	4285 (68)	3153 (78)	32.6 (0.5)	20.1 (0.4)	11.7 (0.3)
2	3544 (19)	2520 (31)	29.0 (0.5)	16.9 (0.2)	9.8 (0.2)
3	2747 (7)	1683 (22)	30.3 (0.2)	20.5 (0.2)	11.6 (0.3)
4	2732 (13)	1692 (6)	30.7 (0.2)	20.8 (0.2)	11.8 (0.1)

Table 1

*Characteristics of the slurry used in each experiment. Value are expressed on a fresh weight bases (Standard deviation shown in paranthese).*

## 2.2. Laboratory treatment system

The laboratory treatment system (figure 1) consisted of a ten litre glass reactor (5 litre working volume), a feed tank (5l) and a discharge tank (5l). A detailed description was given in a previous paper<sup>6</sup>.

### Continuous aeration

The reactor was continuously fed with a peristaltic pump and was discharged every 4 hours with a second peristaltic pump. The slurry was mixed in the reactor by a magnetic stirrer and a flow rate of slurry recirculated from the bottom to the top of the vessel at a flow rate approximately of 0.3 m<sup>3</sup>/h. This flow of slurry resulted in mixing, aeration and foam control. Redox potential was continuously monitored in the flow of slurry and recorded on a data logger. This data logger could be programmed with a set point for redox potential to enable two solenoid valves to switch and allow the entry of air or di-nitrogen gas into the system in order to control the aeration level. The injection of air or di-nitrogen gas resulted in a constant gaseous flow rate which was quantified by a gas meter.

### Intermittent aeration

The reactor was fed at the beginning of each anoxic period with a peristaltic pump and was discharged at the end of each anoxic period with a second peristaltic pump. The slurry was mixed in the reactor by a magnetic stirrer during both periods (aeration and anoxic) and a flow rate of slurry recirculated from the bottom to the top of the vessel at a flow rate approximately of 0.3 m<sup>3</sup>/h during aeration period. This flow of slurry resulted in mixing, aeration and foam control during aeration period and the cut off of this flow allow anoxic conditions. Continuous injection of air resulted in a constant gaseous flow rate which was quantified by a gas meter.

For both processes, residence time was controlled by fixing the rate of feeding of raw slurry. Gaseous flow rate was monitored continuously for nitrous oxide by non-dispersed infrared analyzer. Ammonia emissions were quantified by recirculating the gas through an acid trap (H<sub>2</sub>SO<sub>4</sub>, 0.5N).



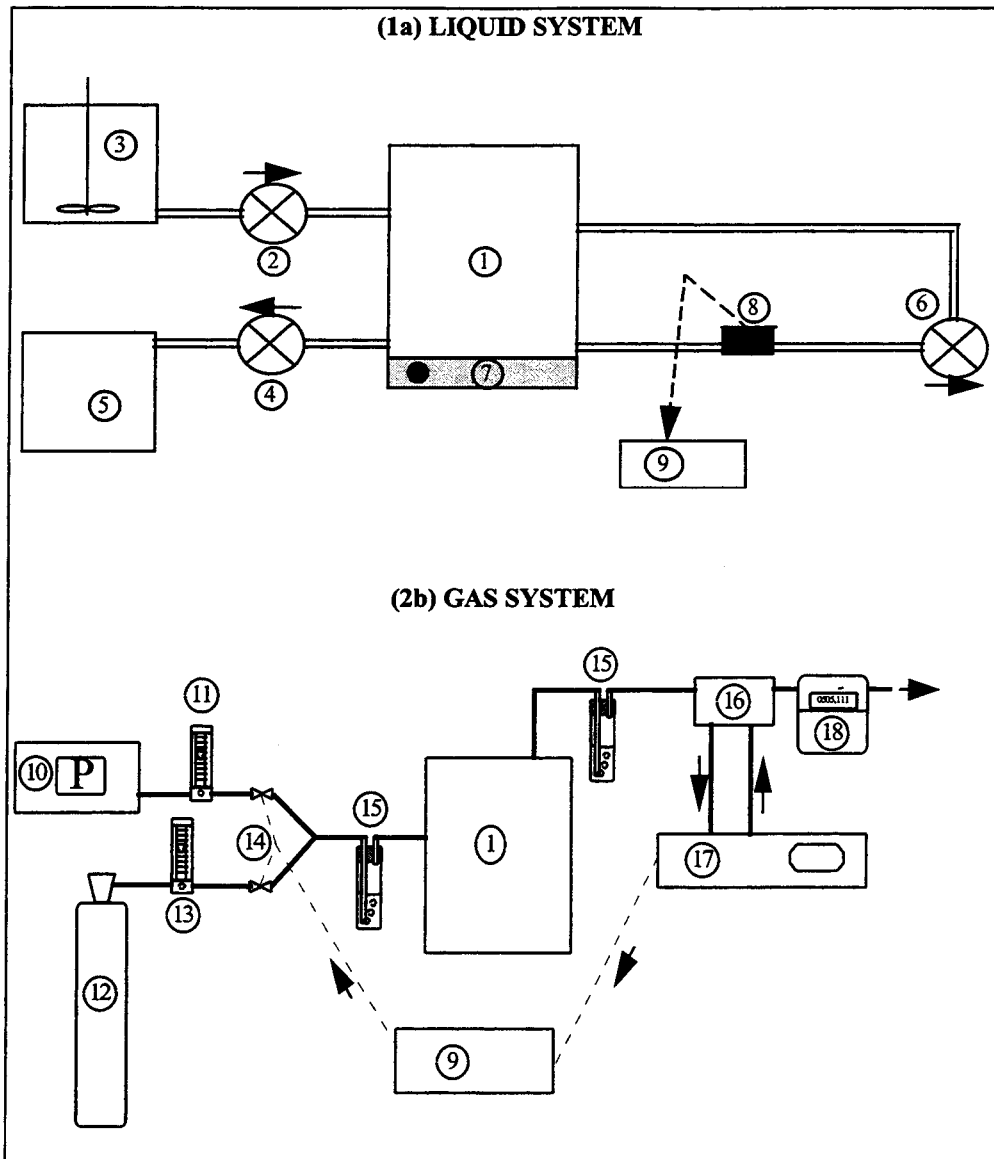

Figure 1

Laboratory treatment system showing : aeration reactor (1), feed slurry peristaltic pump (2), feed slurry vessel (3), discharged slurry peristaltic pump (4), discharged slurry vessel (5), recirculation peristaltic pump (6), magnetic stirrer (7), redox potential sensor (8), data logger (9), air pump (10), gas flow meter (11 and 13), di-nitrogen gas compressor (12), solenoid valves (14), acid trap for ammonia (15), buffer vessel (16), infrared analyzer (17), and gas meter (18).

In each experiment, analyses started after a period equal to three residence times. Representative samples of raw slurry and treated slurry were then taken daily throughout a two week monitoring period and analyzed for total solids (TS), total suspended solids (TSS), volatile suspended solids (VSS), total nitrogen (TN), total ammoniacal nitrogen (TAN), nitrate and nitrite. The values obtained were averaged over the monitoring period and the values indicated in this paper are the means values of 10-15 individual analyses. All input and output slurry quantities were recorded daily in order to establish mass balances during the monitoring period. Two continuous aeration runs were carried out with different aeration level in order to evaluate the effect of oxygen dissolved on N<sub>2</sub>O emissions. Concurrently, two intermittent aeration runs were performed with different anoxic period times. A total of 4 runs were evaluated with residence time of ca. 5 days; these are summarized in table 2.

Runs	Residence time (days)	Regimes
1	4.6	- Continuous feeding - Sequential discharging (every 4 hours) - Continuous aeration with redox control at 0 mV Ag/AgCl
2	4.8	- Continuous feeding - Sequential discharging (every 4 hours) - Continuous aeration with redox control at -50 mV Ag/AgCl
3	4.5	- Sequential feeding (at the start of each anoxic period) - Sequential discharging (at the end of each anoxic period) - Intermittent aeration with 2.5 hours of aeration and 1.5 hours of anoxic period
4	4.5	- Sequential feeding (at the start of each anoxic period) - Sequential discharging (at the end of each anoxic period) - Intermittent aeration with 1.5 hours of aeration and 2.5 hours of anoxic period

*Table 2*  
*Treatment regimes*

### 2.3. Chemical analyses

TAN was analyzed by steam distillation using MgO. Nitrate plus nitrite were determined after reduction with Devarda's alloy, and nitrate by the same method following destruction of nitrite with sulphamic acid. Nitrite was obtained by difference. Samples were digested using the Kjeldahl procedure for raw slurry or Olesen modified procedure<sup>7</sup> for treated slurry and distilled with NaOH (30%) to determine TN, TS, TSS, VSS were analyzed by standard methods (APHA, 1992<sup>9</sup>). All nitrogen analyses, particularly nitrate and nitrite were made within one hour of sampling. For the other analyses, samples were kept at 4°C (storage < 2 days) or frozen (storage > 2 days).

### 3. Results and discussions

#### 3.1. Nitrogen transformations

Residences time were closed to 5 days in all treatment, and in this conditions, no transformation in organic nitrogen pool was observed. Thus, only mineral pool is consider and the results of nitrogen behaviour during treatment, expressed as the percentage of the TAN of the raw slurry, are presented in figure 2.

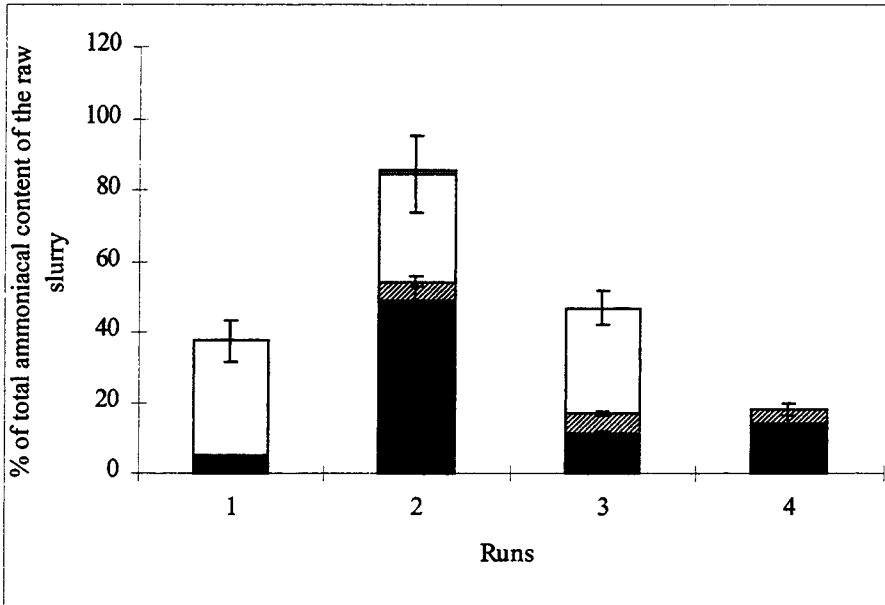

Figure 2

Nitrogen behaviour during aeration of pig slurry, ■ ammonium, ▨ nitrate plus nitrite, □ nitrous oxide and ▩ ammonia (Vertical line =  $\pm$  standart deviation).

We observed an ammoniacal nitrogen oxidation of 95.5% with redox potential controled to 0 mV<sub>Ag/AgCl</sub> (run 1) whereas it was only of 51% with redox potential controled to -50 mV<sub>Ag/AgCl</sub> (run 2). Further experiments shown an increase of ammonium concentration in the reactor (Fig 3) when redox potential fall from 0 to -50 mV<sub>Ag/AgCl</sub>. Also, it appears that oxygen supplied become a limiting factor when redox potential fall below 0 mV<sub>Ag/AgCl</sub>. Concurrently, ammonium oxidation varied between 85.8 and 88.8% using intermittent aeration (Run 3 and 4). Residual ammonium concentrations were, in these cases, partly due to the ammonium supplied by the feeding at the start of the anoxic period.

Low aeration level and intermittent aeration allow denitrification to occur<sup>9,10</sup>. Also, a large part of oxidized ammonium was removed as gas (89 - 95.5%).

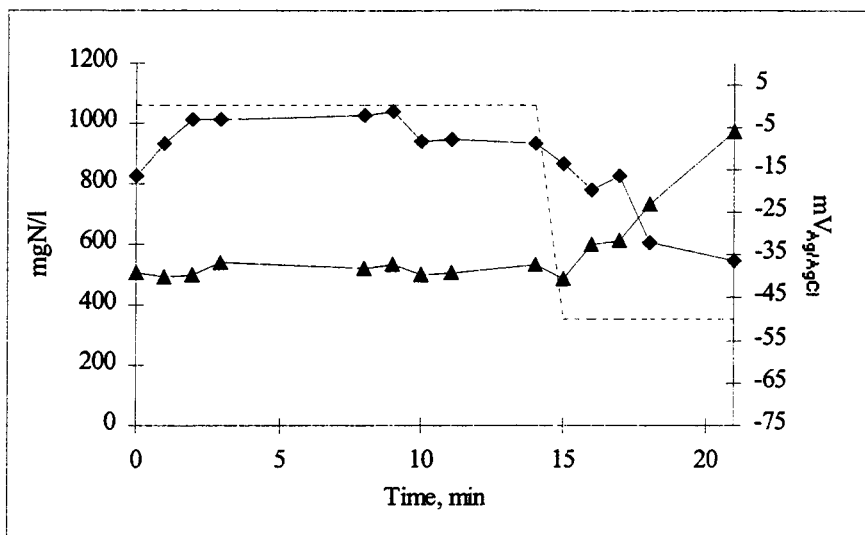
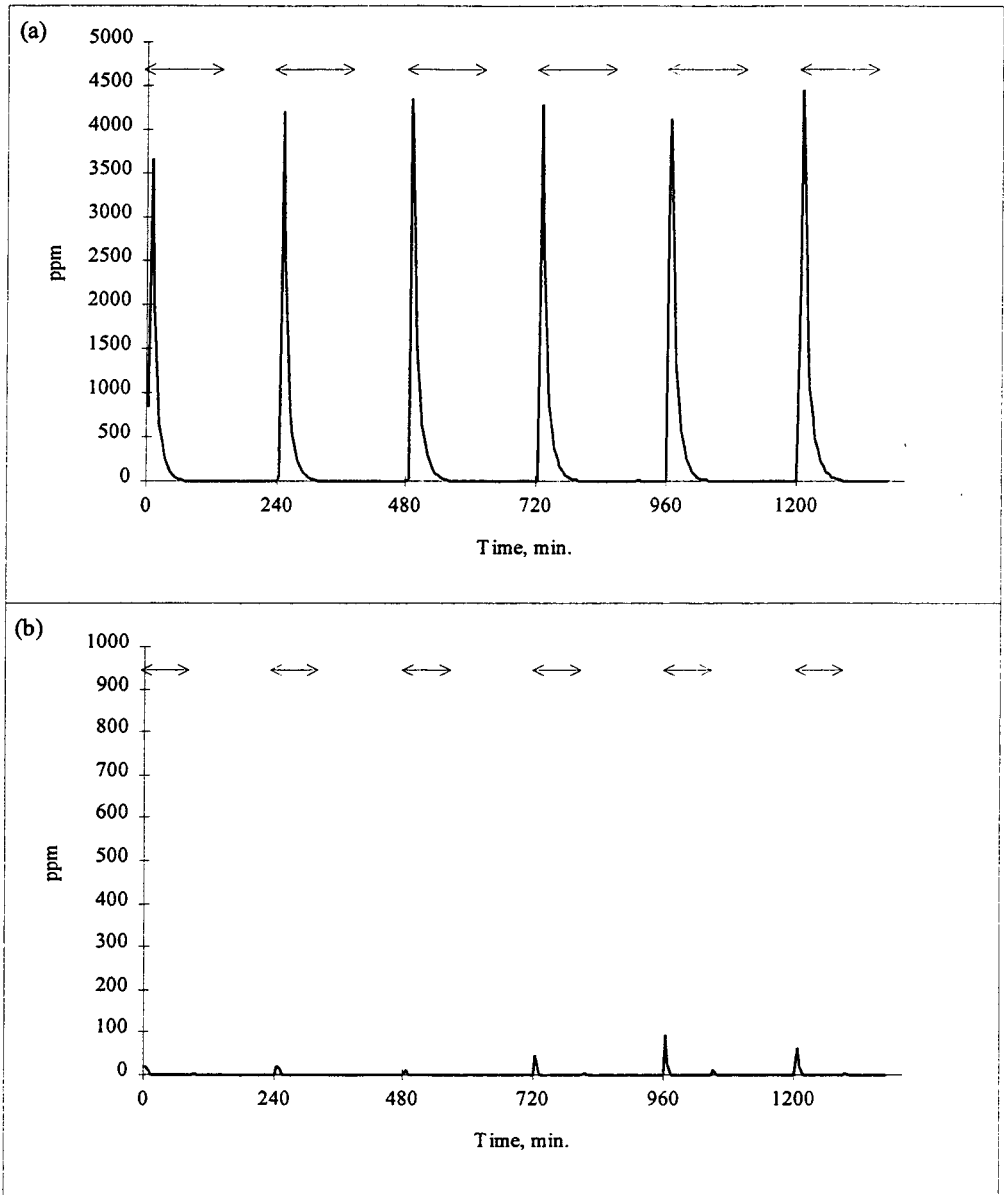

Figure 3  
 Influence of redox potential on nitrogen transformation during aerobic treatment of pig slurry, ◆ nitrate plus nitrite concentration, ▲ ammonium concentration and ----- redox potential.

### 3.2 Gaseous emissions

As observed by Osada *et al.*<sup>5</sup>, the removal of oxidized ammonium led to N<sub>2</sub>O emissions in case of continuous aeration. N<sub>2</sub>O emissions represented between 30 and 33% of the TAN of the raw slurry. The decrease of redox potential from 0 (run 1) to -50 mV<sub>Ag/AgCl</sub> (run 2) did not prevent these emissions. Contrary to Osada *et al.*<sup>5</sup>, the use of intermittent aeration (run 3) did not reduce systematically the N<sub>2</sub>O emissions. Indeed, the N<sub>2</sub>O emissions was, in this run, similar to continuous aeration (30%). Nevertheless, the continuous monitoring of gaseous emissions allowed us to observed that emissions occurred mainly at the start of aeration stage (Fig 4a).

N<sub>2</sub>O emissions were assumed to be due, in this run, to the stripping of N<sub>2</sub>O produced during incomplete denitrification and trapped in the slurry. Indeed, foam avoided exchange between air and slurry during anoxic stage. Also, an increase of the time of anoxic period (run 4) enabled to a full denitrification into di-nitrogen gas and prevented N<sub>2</sub>O emissions (fig 4b).



**Figure 4**  
 Continuous emissions of nitrous oxide during intermittent aeration,  
 $\longleftrightarrow$  aeration period. (a: run 3 and b: run 4).

Incomplete oxidation of ammonium in run 2 led to ammonia emission which represented near 1% of total ammoniacal content of the raw slurry. Nevertheless, a full nitrification of ammonium (run 1, 3 and 4) resulted in the low ammonium concentration in the reactor avoiding these emissions.

## 4. Conclusions

Nitrogen removal between 82 and 95% of the total ammoniacal nitrogen content of the raw slurry could be obtained during aerobic treatment of pig slurry using nitrification and denitrification processes. Continuous aeration with low level of aeration and intermittent aeration allow nitrification and denitrification to occur. Nevertheless, continuous aeration leads systematically to nitrous oxide emissions representing up to 33 % of the total ammoniacal nitrogen content of the raw slurry whereas the use of intermittent aeration can prevent these emissions using a long time of anoxic period to allow complete denitrification. Moreover, ammonia emissions can be avoided by a complete oxidation of ammonium.

## 5. Acknowledgment

The authors would like to acknowledge the Conseil Régional de Bretagne and the Ministère de l'Agriculture et de la Pêche (DERF) for funding these studies.

## 6. References

- <sup>1</sup> **IPCC.** Climate change. In: The IPCC Scientific Assessment. 1990 (Eds. Houghton J T; Jenkins G J; Ephraums J J). Cambridge University Press.
- <sup>2</sup> **Crutzen, P.J.** Atmospheric chemical processes for the oxides of nitrogen including nitrous oxide. In: Denitrification, nitrification and atmospheric nitrous oxide, 1981, (Eds. Delwiche C C). Wiley, New York, pp 17-45.
- <sup>3</sup> **Burton, C.H.; Sneath, R.W.; Farrent, J.W.** The effect of continuous aerobic treatment on the fate of the nitrogen in piggery slurry. In: Nitrogen Flow in Pig Production and Environmental Consequences, Symposium Proceedings, Wageningen, 8-11 June, 1993, (Eds. Verstegen M V A; den Hartog L A; van Kempen G J M; Metz J H M). EAAP vpubl. no. 69: 404-409.
- <sup>4</sup> **Willers, H.C.; Derikx, P.J.L.; Ten Have, P.J.W.; Vijn, T.K.** Emission of ammonia and nitrous oxide from aerobic treatment of veal calf slurry. Journal of Agricultural Engineering Research 1996, 63:345-352.
- <sup>5</sup> **Osada, T.; Kuroda, K.; Yonaga, M.** Reducing nitrous oxide gas emissions from fill-and-draw type activated sludge process. Water Research 1995, 29: 1607-1608.
- <sup>6</sup> **Béline, F.; Martinez, J.; Chadwick, D.; Guiziou, F.; Coste, C.-M.** Factors affecting nitrogen transformations and related nitrous oxide emissions from aerobically treated slurry. Journal of Agricultural Engineering Research 1999, (in press).

<sup>7</sup> **Dimmock, S.J.; Martinez, J.** Nitrite plus nitrate recoveries in piggery slurry by direct distillation and modified kjeldahl methods. *Bioresource Technomogy* 1994, 48: 21-24.

<sup>8</sup> **APHA, AWWA, WEF** (1992). Standard methods for the examination of water and wastewater - 18th edition, Greenberg, A.E.; Clesceri, L.S.; Eaton, A.D.; eds, Washington DC, USA.

<sup>9</sup> **Smith, M.P.W.; Evans, M.R.** The effects of low dissolved oxygen tension during the aerobic treatment of piggery slurry in completely mixed reactors. *Journal of Applied Bacteriology* 1982, 53: 117-126.

<sup>10</sup> **Bicudo, J.R.; Svoboda, I.F.** Effects of intermittent-cycle extended-aeration treatment on the fate of nutrients, metals and bacterial indicators in pig slurry. *Bioresource Technology* 1995, 54: 63-72.

## **Anaerobic processing of slaughterhouse wastewater in a SBR.**

*Le traitement des eaux usées d'abattoir par digestion anaérobie dans un bioréacteur à opérations séquentielles.*

**D. I. Massé, L. Masse, N. Bourgeois**

Dairy and Swine Research and Development Centre,  
Agriculture and Agri-Food Canada,  
2000 Rte 108E, Lennoxville Quebec, Canada, J1M 1Z3  
E-mail : MASSED@EM.AGR.CA

### **Abstract**

*Abattoir effluents reaching rivers and streams may contribute significant levels of biological oxygen demand (BOD) and other nutrients, resulting in riverbed and stream pollution. At the present time, there is no economical, stable, efficient, easy-to-use and operate process to stabilize, deodorize, or recover usable energy from slaughterhouse wastewater. The Agriculture and Agri-Food Canada Research Center is currently evaluating the feasibility of using anaerobic digestion in sequencing batch reactors to treat slaughterhouse effluents. Experiments were conducted in four, 42 L bioreactors operated at 30°C. Preliminary results indicate that this process is very effective in reducing odours and the pollution potential of slaughterhouse wastewater. The process removed up to 98% and 91% of the total COD and suspended solids respectively. It also yielded a large quantity of high quality biogas (0.54-0.67L / g of VS fed) with a methane content of 70 to 75%. The proposed process is very stable and easy-to-operate.*

### **Résumé**

Dans certaines régions, la gestion actuelle des eaux usées d'abattoirs cause de sérieux préjudices à l'environnement. Ces eaux usées sont principalement composées d'un mélange complexe de matières grasses, de protéines et de fibres. Elles contiennent une concentration suffisante : a) de matières organiques pour appauvrir la teneur en oxygène des eaux de surfaces, b) de nutriments pour stimuler la prolifération des algues. Donc le rejet des eaux usées d'abattoir dans les cours d'eau a des conséquences néfastes sur la flore et la faune aquatiques. De plus, le public augmente les pressions auprès des gouvernements locaux et provinciaux afin que l'industrie des viandes adopte une gestion plus écologique de ses effluents. Le rejet libre des eaux usées dans l'environnement n'est plus une solution acceptable. Actuellement, il y a un besoin urgent pour une biotechnologie environnementale économique, simple à utiliser, stable, performante et facilement intégrable dans les abattoirs.



- Agriculture et Agro-alimentaire Canada réalise actuellement une étude de faisabilité concernant l'utilisation des bioréacteurs anaérobies à opérations séquentielles pour le traitement des eaux usées d'abattoir. Les expériences ont été effectuées dans quatre (4) bioréacteurs anaérobies de 42 l, à opérations séquentielles. La température d'opération et le taux de chargement organique étaient de 30°C et 5.75 g DCO L<sup>-1</sup>d<sup>-1</sup> respectivement. Le procédé a réduit la demande chimique en oxygène (DCO) totale de 91%, et a éliminé jusqu'à 85% des matières volatiles solides. Un biogaz de haute qualité, contenant 70 à 75% de méthane, a été produit (0.56 - 0.64 l CH<sub>4</sub>/g MVS alimenté). De plus, cette technologie qui est très stable et simple d'utilisation, désodorise complètement les eaux usées.

## 1. Introduction

Slaughterhouse wastewater has a complex composition and is very harmful to the environment (Polprasert et al., 1992). It is strong compared to domestic wastewater. After the initial screening of coarse solids, slaughterhouse wastewater is mainly composed of diluted blood, fat, and suspended solids. It may also contain some manure.

In Québec and Ontario, most slaughterhouses send their wastewater to a municipal treatment plant. However, in order to minimise surcharge costs exacted by municipalities, larger slaughterhouses usually apply some type of primary and/or chemical pre-treatment to the wastewater. These include the screening of coarse solids, air flotation tank for fat recovery and the addition of chemicals for fat and protein reduction, etc. These treatments, however, are somewhat costly and are not sufficient to totally eliminate surcharge costs which are bound to increase in the more populated areas.

At the present time there is no economical, stable, easy-to-use and operate process to stabilize, deodorize, or recover usable energy from slaughterhouse wastewater in Canada. Anaerobic processes that were experimented in the past concentrated mainly on energy production and less consideration was given to pollution potential reduction. However, anaerobic digestion in a Sequencing Batch Reactor (SBR), as developed by Agriculture Canada, could be an interesting alternative for an efficient and economical treatment (or pre-treatment) of slaughterhouse wastewater. This new technology, which had been successfully applied in the laboratory to the treatment of swine manure slurry, can operate with limited capital costs, energy and manpower.

The objectives of this study were to characterize wastewater from slaughterhouses in eastern Canada, and to determine the feasibility of using anaerobic digestion in an ASBR to treat slaughterhouse wastewater at a temperature of 30 C. In this study, the process stability will be considered as the most important criterion for the

evaluation of the technology. The slaughterhouse industry needs a process that is very stable and not affected by variations in wastewater temperature and strength.

## 2. Literature review

The nature and composition of slaughterhouse wastewater have been discussed in detail by Hammer and Jacobson (1970) and Issac and Anderson (1974). The major characteristics are: 1) high organic strength; 2) sufficient organic biological nutrients; 3) adequate alkalinity; 4) relatively high temperature (20 to 30 C); and 5) free of toxic material. Metzner and Temper (1990) indicated that slaughterhouse wastewaters with the above characteristics are well suited to anaerobic treatment. Full scale anaerobic lagoon systems have been used to treat slaughterhouse wastewater, (Enders et al. 1968; Wymore and White 1968). The efficiency of these lagoons in reducing the BOD<sub>5</sub> ranged between 60 and 90%. Suspended solids removal was not reported. These anaerobic lagoons were not covered. The only natural protection against exposure of anaerobic bacteria to air was provided by a layer of grease that floated on the liquid surface. The biogas produced, including methane escaped directly to the atmosphere. Release of methane to the atmosphere is not an acceptable practice anymore. Methane has a high heat trapping capacity and is a major component of greenhouse gas. A large floating cover could be used to collect the biogas at the surface of the lagoon. Such a system would work well in the absence of cold weather. Here in Canada, the construction of a lagoon cover with enough durability and strength to resist large unbalanced forces due to ice and snow accumulation would be very costly. Also, the temperature in the lagoon would be very low during the winter. As a result, the anaerobic lagoon system would not adequately process the wastewater. Also if a process failed in a large lagoon, it would not be possible to restart it.

To accelerate the treatment and to reduce area requirements, more sophisticated anaerobic systems involving digesters (as opposed to lagoons) have been used to treat slaughterhouse wastewater. Sayed et al. (1987; 1988) used upflow anaerobic sludge blanket reactors to treat the wastewater. Metzner and Temper (1990) and Tritt (1992) used fixed-bed reactors for the anaerobic digestion of slaughterhouse wastewater. These reactors were very effective in removing the soluble organic (efficiency > 90%) but their efficiency in removing the suspended solids was very low 31 to 60%. The low efficiency in removing the suspended solids was due to the hydraulic conditions inside these reactors. Suspended solids were maintained in suspension by the continuous influent flow, and were therefore present in the digester effluent. With this system, a secondary clarifier to settle the suspended solids and a recirculation system to return the suspended solids to the reactor are required. The addition of these equipments substantially increased the capital cost and the operation complexity of the process. Its operation required a skilled technician.

An anaerobic process would be attractive to the slaughterhouse industry if a low cost, simple, efficient and easy-to-operate process was available. The sequencing batch reactors has the potential to be a low cost as well as an efficient system to remove both soluble COD and suspended solids. SBR indicates that the process occurs in a tank in the sequence given in Figure 1: fill; react; settle; draw and idle. During the fill period the wastewater is added to the tank. During the react period the alimentation is stopped. During both the feed and react periods the soluble COD and some of the organic particulate are removed biologically by microorganisms action. During the settling period, no mixing is provided. This provides quiescent conditions (optimum conditions) for the separation of treated wastewater and suspended solids. Dague et al. (1992) stated that in an anaerobic sequencing batch reactors the Food/Microorganisms ratio is high after the filling period and low just prior to the settling period. They also indicated that the above operating conditions result in efficient bioflocculation and solids separation. Dague et al. (1992) also stated that with a SBR the partial pressure of C02 above the liquid zone is maintained in the reactor during the settling period. As a result no significant quantity of C02 is transferred to the head space during the settling period. The abscence of mixing and CO2 transfer results in quiescent settling conditions for the suspended solids. This operation retains a very high concentration of microorganisms in the digester. Previous systems used secondary clarifier and degasification equipment to recover the anaerobic bacteria. But because the secondary clarifier never provided quiescent conditions, bacteria were still washed out of the system. In several cases, this led to process failure.

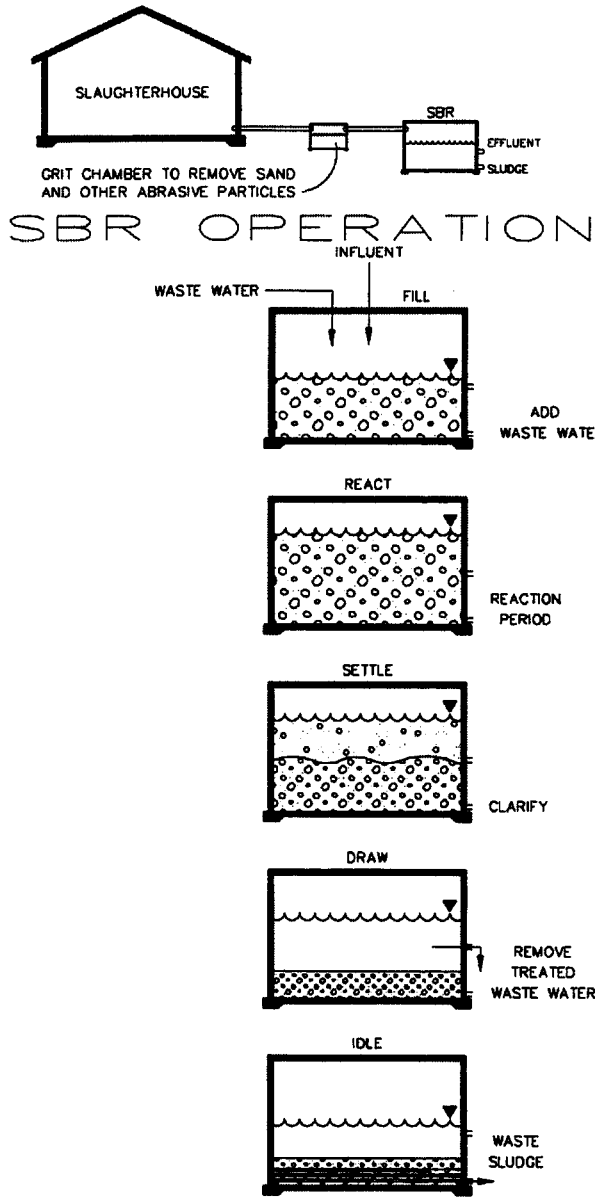

Figure 1  
Operation of the ASBR process.

### 3. Analysis of wastewater from different slaughterhouses

Wastewater samples were collected at various locations in the wastewater treatment area of six slaughterhouses. Table 1 presents the composition of the raw wastewater, prior to any treatment except for the screening or settling of coarse solids. Screens and primary settling tanks are usually situated at the inlet of the wastewater treatment area and it is often difficult to sample before that point. Table 1 shows that the strength of raw wastewater varies among slaughterhouses but variation seems to be independent of plant capacity: smaller slaughterhouses do not produce stronger or weaker wastewater. Total COD, suspended solid (SS), total nitrogen (TKN), and total phosphorus (P) concentrations of the raw wastewater collected at the six slaughterhouses are 2 to 9 times higher than those of a strong domestic wastewater which has a total COD of 1000 mg/L, a SS content of 350 mg/L, and TKN and P concentrations of 85 and 15 mg/L, respectively (Metcalf & Eddy, 1991).

Parameters (mg/l)	1	2	3	4	5	6
COD total	2941	3589	4976	2333	9368	3417
COD soluble	1510	2605	2817	778	4551	1250
Total solids	2244	2727	3862	2747	6037	2481
Volatile solids	1722	1966	3153	1204	4745	1846
Suspended solids	957	736	1348	877	2397	1431
Volatile suspended solids	770	576	1192	594	2182	1149
Total Kjeldahl nitrogen	174	271	372	90	629	158
Ammonia	41	154	99	19	185	20
Protein	133	117	272	71	444	137
Total phosphorous	20	-	-	28	61	80
pH	6.7	7.2	6.5	4.9	7.0	6.5
CaCO <sub>3</sub>	333	333	333	83	1014	250

*Table 1*

*Analysis of raw wastewater from six slaughterhouses prior to any treatment except the screening or settling of coarser solids.*

Wastewater samples were always collected in the morning or early afternoon and did not include water from the afternoon washing or from emptying the hot water tank used to wash the animals during the day. The raw wastewater collected was thus probably stronger than a 24 hour-composite sample which would include wash water. Table 2 presents the range of values as well as the coefficients of variation for the different parameters tested in the raw wastewater samples from slaughterhouse. For most parameters, overall variation was less than 20%. However, the highest total and soluble COD contents (11 530 and 5490 mg/L, respectively) were 60 to 65% higher than the lowest values (6908 and 3449 mg/L). Total and soluble COD contents are important parameters when designing a wastewater treatment system. Therefore a system to treat slaughterhouse wastewater would have to be able to sustain these variations in influent COD.

Parameters	Range (mg/l)	Coefficient of variation (%)
COD total	6908 - 11530	16
COD soluble	3449 - 5490	19
Total solids	4892 - 7121	16
Volatile solids	3647 - 5724	23
Suspended solids	2135 - 2700	10
Volatile suspended solids	1936 - 2427	10
Total Kjeldahl nitrogen	534 - 735	12
Ammonia	89 - 246	36
Protein	288 - 530	22
pH	7.0 - 7.1	0
CaCO <sub>3</sub>	917 - 1056	6

*Table 2*  
*Variation in raw wastewater quality at Slaughterhouse 5*  
*during four sampling over a six-month period.*

#### **4. Evaluation of anaerobic digestion in a SBR**

##### **Materials and Methods**

Figure 2 is a schematic diagram of the bench scale SBRs used in this study. Four 42 L plexiglass digesters were located in a controlled temperature room. The SBRs were mixed by recirculating the biogas. Wet cup gas meters were used to measure the daily biogas production. The feed samples were stored in a freezer at -15 C to prevent biological activity. They were heated to the digester operating design temperature (30 C) prior to feeding.

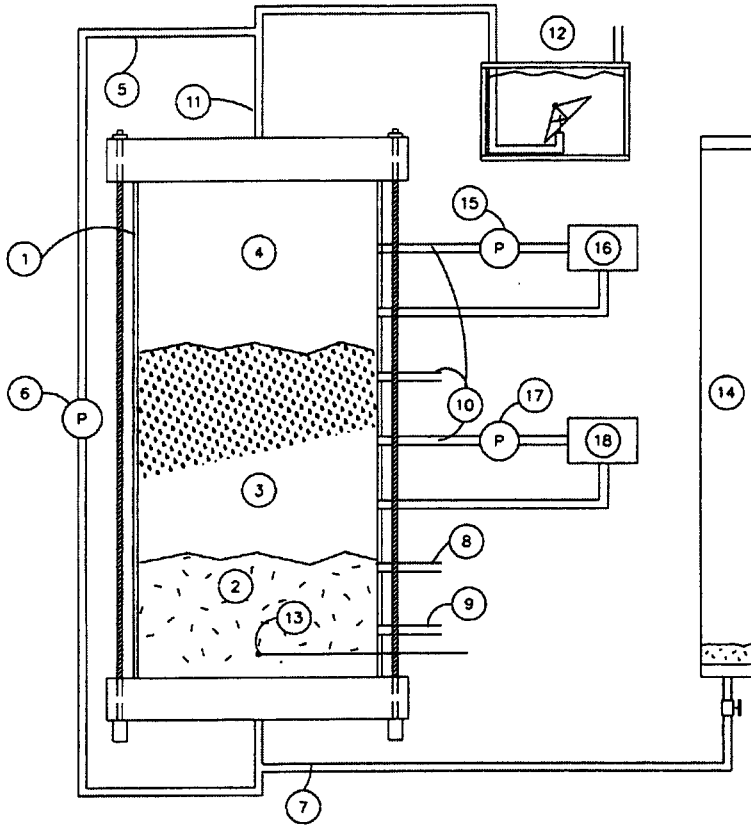

- |  |  |
|--|--|
| 1 300 mm DIAMETER PLEXIGLASS DIGESTER                  | 10 MIXED LIQUOR OR SUPERNATANT SAMPLING PORT |
| 2 SLUDGE BED ZONE                                      | 11 GAS OUTLET                                |
| 3 VARIABLE VOLUME ZONE                                 | 12 GAS METER                                 |
| 4 HEAD SPACE ZONE                                      | 13 THERMOCOUPLE                              |
| 5 GAS RECIRCULATION LINE                               | 14 FEEDER TUBE                               |
| 6 BIOGAS RECIRCULATION PUMP                            | 15 GAS PUMP                                  |
| 7 INFLUENT LINE  | 16 HYDROGEN GAS MONITOR                      |
| 8 EFFLUENT LINE  | 17 LIQUID PUMP                               |
| 9 SLUDGE SAMPLING PORT, ALSO USE FOR<br>SLUDGE WASTAGE | 18 DISSOLVED HYDROGEN GAS MONITOR            |

*Figure 2*  
*Schematic of laboratory scale SBRS*

## Operating Conditions

For startup run, the effects of inoculum type on process start-up was investigated. Fill and react period lengths were kept constant and intermittent mixing was provided (1 minute every 5 minutes) to the SBRs. Operating conditions for the start-up run are given in Table 3. Digesters 1 and 2 were initially started using 13 L of anaerobic granular sludge obtained from the anaerobic wastewater treatment plant of Agropur Co-Operative dairy plant at Notre-Dame du Bon Conseil, Quebec. Digesters 3 and 4 received 13 L of anaerobic non-granulated sludge obtained from the Robert O. Pickard Environmental Centre, Ottawa, Ontario. The Agropur sludge substrate consisted mainly of fats and proteins. The anaerobic municipal sludge substrate comes from both primary and secondary clarifiers. Composition of the Agropur and municipal anaerobic sludge are given in Table 4.

Digester No	Feeding frequency (# / week)	Fill period (hr)	React period (hr)	Sludge Type
1-2	3.5	1	41	A
3-4	3.5	1	41	B

A - Agropur sludge. B - Municipal sludge.

*Table 3*  
*SBR Operating conditions*

CONSTITUENT	AGROPUR SLUDGE	MUNICIPAL SLUDGE
Total solids %	7.5	4.9
Total suspended solids %	7.3	4.8
Volatile solids %	3.2	2.8
Volatile suspended solids %	3.2	2.7
Soluble COD g/l	0.7	0.7
Total COD g/l	89.7	62.5

*Table 4*  
*Inocula characteristics*

## Monitoring and Sampling

Biogas production was monitored daily and the biogas composition weekly. The feed, digester mixed liquor and effluent were analysed for soluble and total COD, solids contents (TS, VS, fixed solids, TSS, fixed suspended solids), ammonia and total nitrogen, VA concentration, pH and alkalinity. The analytical procedures used to determine the above parameters were carried out according to standard methods (APHA, 1989). Gas composition and VA concentrations were determined by gas chromatography.



## 5. Result and discussion

The startup period was divided into three runs corresponding to three different feed stocks from the slaughterhouse (Table 5). The ASBRs were fed every two days. The loading rate was slowly increased from 1.1 g COD per litre of digester mixed liquor at the beginning of run 1 to 11.5 g COD/L at the end of run 3. Table 5 gives average concentrations of total and soluble COD, solids and nutrients in the raw wastewater fed to the ASBRs and in the effluents from the ASBRs for the three runs. It also gives the level of removal of these compounds.

Run n°	Parameters	Influent (mg/l)	Effluent		% Removal	
			Agropur sludge (mg/l)	Municipal sludge (mg/l)	Agropur sludge A	Municipal sludge B
1	Total COD	6908	1511	1450	78	79
	Soluble COD	3449	495	512	86	85
	Total solids	4892	2959	2091	40	57
	Volatile solids	3647	1002	987	73	73
	Suspended solids	-	1411	787	-	-
	Volatile sus. solids	-	764	3775	-	-
	Total nitrogen	534	510	741	4	-
	Ammonia	246	444	664	-81	-170
	Protein	288	66	78	77	73
Methane (L/g of VS fed)	-	0.64	0.67	-	-	
2	Total COD	9665	1842	880	81	91
	Soluble COD	4714	159	104	97	98
	Total solids	6098	3381	1742	45	71
	Volatile solids	4864	1406	573	71	88
	Suspended solids	2135	2519	810	-18	62
	Volatile sus. solids	1936	1246	490	36	75
	Total nitrogen	619	621	571	0	8
	Ammonia	89	525	498	-489	-458
	Protein	530	95	73	82	86
Methane (L/g of VS fed)	-	0.55	0.58	-	-	
3	Total COD	11530	601	365	95	97
	Soluble COD	9665	1842	880	81	91
	Total solids	7121	1630	1457	77	80
	Volatile solids	5724	425	303	93	95
	Suspended solids	2658	347	233	87	91
	Volatile sus. solids	2427	238	135	90	94
	Total nitrogen	735	645	552	12	25
	Ammonia	221	612	536	-177	-143
	Protein	514	33	16	94	97
Methane (L/g of VS fed)	-	0.56	0.54	-	-	

Table 5  
Quality of wastewater before and after anaerobic treatment in SBRS

High COD removal was achieved in all the experimental runs, especially in the last run of the startup period when total COD was reduced to 601 and 365 mg/L (95% and 97% removal) by sludge A and B, respectively. VS removal ranged from 73% in run 1 to 95% in run 3. The reduction in soluble COD was due to microbial activity while total COD and VS removal were due to both microbial activity and solids settling. Both types of anaerobic sludge had excellent settling characteristics even though the quiescent conditions were sometimes disturbed by biogas production during the settling period. In this experiment, TSS concentration in the effluent from run 3 was as low as 347 and 233 mg/L for sludge A and B, respectively. It corresponded to over 87% and 91% removal, respectively, and was well below the TSS maximum allowed by municipalities. Total Kjeldahl nitrogen concentration remained high in the effluent but the organic nitrogen was mostly converted to ammonium during the process. Ammonia-nitrogen represented 20 to 50% of the influent TKN but accounted for over 90% of the TKN in the ASBR effluent.

The ASBRs produced a high quality biogas which contained approximately 74% methane and 25% CO<sub>2</sub>. Methane production varied between 0.54 and 0.67 L/g VS fed. There was no acetic, propionic or butyric acids accumulation in the bioreactors, indicating that the technology is very stable. The effluent had an average pH of 7.6, which was slightly higher than that of the influent. Alkalinity was increased from approximately 900 mg/L as CaCO<sub>3</sub> in the influent to about 2500 mg/L in the effluent. The increase in alkalinity will improve the buffering capacity of the wastewater and is thus beneficial. The effluent was almost odourless when compared to the raw slaughterhouse wastewater. Also, the dark red colour of the raw wastewater completely disappeared and the treated wastewater had a pale yellowish colour.

The anaerobic sludge had excellent settling characteristics. When mixing was stopped at the end of the react period, a settling zone or liquid/solids interface was forming and the sludge blanket completely settled at the bottom of the SBR. Another very important feature of ASBR process is that it does not require continuous feeding. Therefore, in slaughterhouse applications it should be loaded during the day and react at night. Therefore the SBR will make use of existing wastewater handling equipment at the plant.

## 6. Conclusion

Preliminary data of anaerobic digestion at 30 C in a SBR showed that the proposed technology has good potential to substantially reduced the pollution load of slaughterhouse wastewater. The digester effluents were almost odourless when compared to the raw slaughterhouse wastewater. Also, the SBR was efficient in retaining the biomass. It provided good solids-liquid separation. The proposed process show good potential to provide the slaughterhouse industry with a more environmentally sound wastewater management alternative. It will eliminate the need for expensive air flotation and sedimentation processes currently used at some slaughterhouses. It will also substantially reduce the high treatment cost at plants where the wastewater is discharged to the municipal wastewater system. Finally the above process will recover a significant quantity of energy (methane) that could be used to heat or produce hot water at the slaughterhouse plant.

## 7. Acknowledgement

This project has been financed by the Canadian Meat Council and Agriculture and Agri-Food Canada. The technical support by D. Deslauriers is appreciated.

## 8. References

- Apha**, 1992. Standard Method for the Examination of Water and Wastewater, 18th. ed. American Public Health Association, Washington, D.C
- Dague, R.R., C.E. Habben and S.R. Pipaparti**, 1992. Initial studies on the anaerobic sequencing batch reactor. *Wat.Sci.Tech.*, vol. 26, No. 9-11, pp. 2429-2432.
- Enders, K.E., Hammer, M.J. and Weber, C.L.**, (1968) "Field studies on an Anaerobic Lagoon treating slaughterhouse waste," *Water and Sewage Works*, vol. 115, No. 6, pp. 282-288.
- Hammer, M.D. and C.D. Jacobson**, 1970. Anaerobic lagoon treatment of packing house wastewater. *Proceedings, 2nd International Symposium for waste treatment lagoons*. Kansas City, Missouri.
- Isaac, P.C. and G.K. Anderson** (1974). Waste disposal problems in the food and drink industry: A review in: *Proceedings of Symposium on treatment of wastes from the food and drink industry*. Institute of Water Pollution Wastes, University of Newcastle, Newcastle.

**Massé, D.I., R.L. Droste, K.J. Kennedy, N.K. Patni and J.A. Munroe, 1993.** Psychrophilic Anaerobic Treatment of Swine Manure in Intermittently Fed Sequencing Batch Reactors. ASAE International Winter Meeting, Paper No. 93-4569, Chicago, 22 pp.

**Metcalf & Eddy, Inc., 1991, *Wastewater Engineering: Treatment, Disposal and Reuse*, McGraw-Hill, New York, N.Y., Third Edition.**

**Metzner, G and Temper, U., 1990.** Operation and optimization of a full-scale fixed-bed reactor for anaerobic digestion of animal rendering wastewater. *Wat. Sci.Tech.*, vol. 22, No. , pp. 373-384.

**Polprasert, C., P. Kemmadamrong, and F.T. Tran. 1992.** Anaerobic baffle reactor (ABR) process for treating a slaughterhouse wastewater. *Envir. Technology*. 13:857-865.

**Tritt, W.P., 1992.** The anaerobic treatment of slaughterhouse wastewater in fixed-bed reactors. *Bioresource technology*, vol. 41, pp. 201-207.

**Wymore, A.H., and White, J.E., 1968.** "Treatment of a slaughterhouse waste using anaerobic and aerated lagoons," *Proceedings, 23rd Industrial Waste Conf.*, Purdue University, Lafayette, Ind., pp. 601-618; and *Water and Sewage Works*, vol. 115, No. 10, pp. 492-98.

**Sayed, et al. (1987).** Anaerobic treatment of slaughterhouse waste using a granular sludge UASB Reactor. *Biological Wastes*, vol. 21, No. 1, 11-28.

**Sayed, et al. (1988).** The performance of a continuously operated flocculent sludge UASB reactor with slaughterhouse wastewater. *Biological Wastes*, vol. 24, No. 3, 199-212.

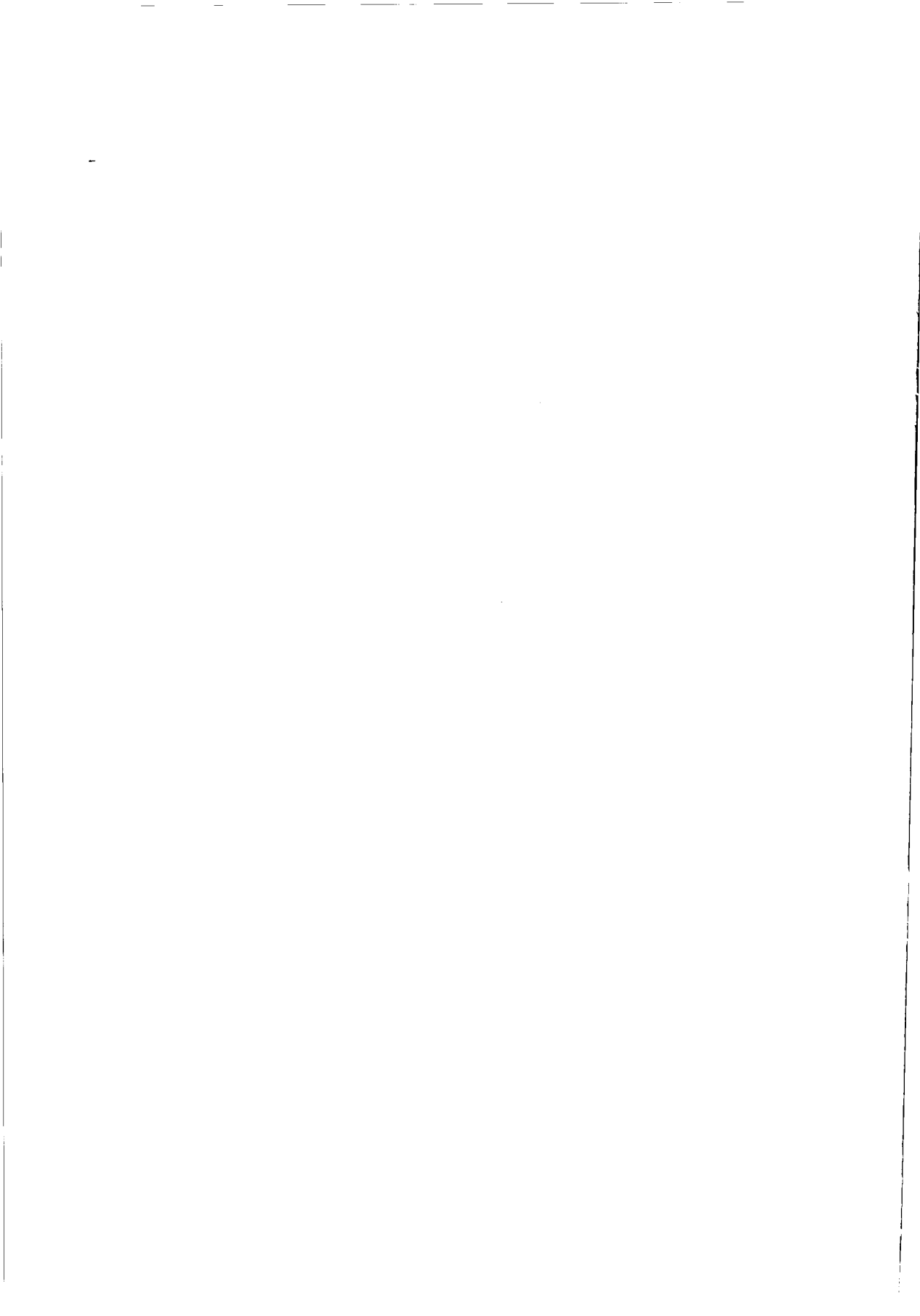

## **Comprehensive pig manure treatment using the BIOSOR™ biofiltration process.**

*Traitement global du lisier de porc par le procédé de biofiltration biosor™.*

**Gerardo Buelna,  
Rino Dubé, Marie-Claude Michel,  
Nicolas Turgeon, Yves Bernard.**  
Centre de Recherche Industrielle du  
Québec (CRIQ). 333 Franquet,  
Sainte-Foy, Québec, Canada G1P 4C7  
E-mail : gbuena@criq.qc.ca

**Paul Lessard**  
Université Laval,  
Department of Civil Engineering,  
Québec, Canada G1K 7P4.

### **Abstract**

*Increasingly stringent standards and heightened public awareness regarding environmental issues has led to an increase in research on various treatment methods used in different countries. Among manure treatment options, organic bed biofiltration represents a very promising technique for treatment and recovery of liquid and gaseous effluent on pig farms.*

*Considering this technology's potential, industrial-scale research and development has been carried out to prove that the BIOSOR™ process is effective in treating pig manure and foul air in farm buildings. This work was recently done on-site at a livestock farm using a 400 m<sup>3</sup> industrial biofiltration system. The system consists of a combined decanter-digester, a protective prefilter and a double-action biofilter.*

*The system performed well despite variations in temperature and organic load at the manure pretank outlet. Despite wide variations in BOD<sub>5</sub> (10 000 - 20 000 mg/L), in SS (10 000 - 20 000 mg/L), in TKN (2 000 - 3 800 mg/L) and in Ptot (500 - 900 mg/L), the BIOSOR™ system was able to maintain an overall pollutant removal performance averaging > 95% for the BOD<sub>5</sub>, > 97% for the SS, > 75% for the TKN and > 87% for the Ptot. By reducing the raw manure's organic load by more than 95%, BIOSOR™ eliminates close to 95% of the odours produced when the manure is transported, stored and spread.*

## Résumé

La sévèrisation des normes et la sensibilisation sans cesse croissante du public aux problèmes environnementaux ont entraîné une recherche accrue de diverses méthodes de traitement dans différents pays. Parmi les alternatives de traitement du lisier de porc, la biofiltration sur support organique constitue une technique très prometteuse pour le traitement et la valorisation des effluents liquides et gazeux des fermes porcines.

Compte-tenu du potentiel de la technologie, des travaux de recherche et développement à grande échelle, visant à démontrer l'efficacité du procédé BIOSOR<sup>MC</sup> lors du traitement du lisier de porc et de l'air vicié du bâtiment de production, ont été réalisés récemment sur le site d'élevage à l'aide d'un système de biofiltration industriel de 400 m<sup>3</sup> de volume. Le système est constitué d'un décanteur-digesteur, d'un préfiltre de protection et d'un biofiltre à double action.

Le système a bien fonctionné malgré les variations de température et de charge organique à la sortie de la préfosse à lisier. En effet, en dépit des fortes variations de DBO<sub>5</sub> (10 000 - 20 000 mg/L), des MES (10 000 - 20 000 mg/L), de NTK (2 000 - 3 800 mg/L) et de P<sub>tot</sub> (500 - 900 mg/L), le système BIOSOR<sup>MC</sup> a permis de maintenir globalement une performance épuratoire moyenne de > 95% pour la DBO<sub>5</sub>, > 97% pour les MeS, > 75% pour NTK et > 87% pour le P<sub>tot</sub>. En réduisant de plus de 95% la charge organique du lisier brut, le procédé BIOSOR<sup>MC</sup> permet d'éliminer près de 95% des odeurs provenant de l'entreposage, du transport et de l'épandage du lisier.

## 1. Introduction

Over the past twenty years, there has been a considerable increase in pig production in Québec. The number of pigs now produced has almost tripled. In 1985, there were 1200 farms with more than 100 sows in their livestock and 793 operations feeding over 1000 pigs a year (1). The growth of this industry has caused a surplus of manure to be disposed of in comparison to the areas available for it to be spread. As a result, there is a greater problem of water, air and soil pollution, not to mention undesirable odours, particularly in and around production buildings, storage areas and when the pig manure is spread (Figure 1). By measuring the intensity and duration of odour emissions, it was established that the sources of odour in Québec were at 20% for buildings, 10% for storage, 5% for recovery and 65% for spreading (2).

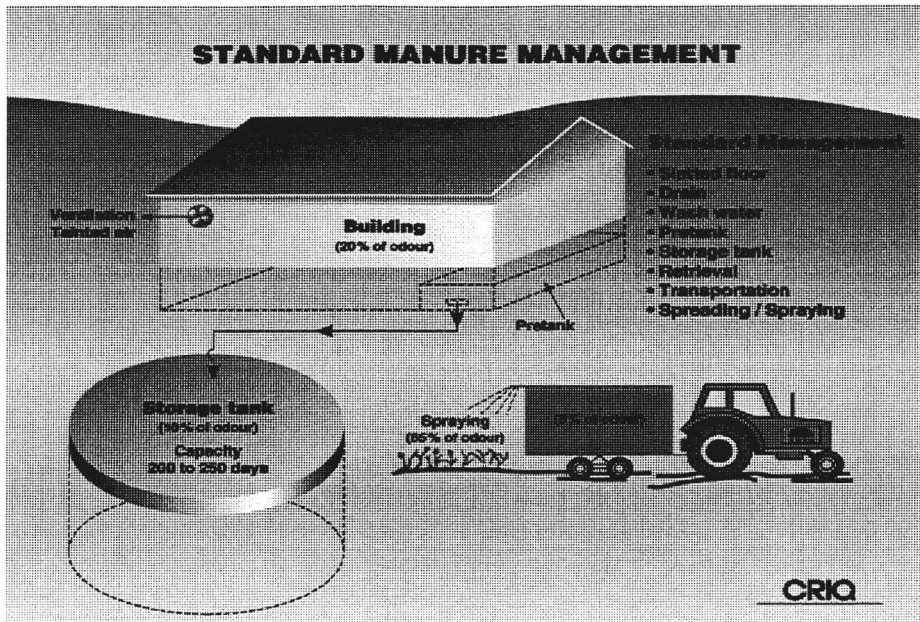

Figure 1  
Standard manure management

Literature on the subject of gas emissions from pig manure indicates that these gases are composed mainly of methane, carbon dioxide, ammonia and hydrogen sulphide (3, 4 and 5). While ammonia is the main component, it is nevertheless not the one with the strongest odour. Literature shows that average concentrations of  $\text{NH}_3$  rarely exceed 66 ppm, while its odour threshold is evaluated at 47 ppm. There has nevertheless been a great deal of monitoring of this compound before and after treatment since it has been identified on the one hand as being responsible for acid rain (6, 7) and, on the other, as a good indicator of odour control during pig manure treatment (8). Trimethylamine and hydrogen sulphide are compounds found in the ambient air of pig farms and have the lowest odour threshold values (respectively 0.00021 and 0.00047 ppm).

A study carried out by ROCHE LTÉE (9) shows that pig manure is a liquid effluent with high concentrations of organic matter (6.7%),  $\text{N}_{\text{total}}$  (0.61%) and  $\text{P}_2\text{O}_5$  (0.33%). The volume of manure produced per day per animal is estimated as being on average 7% of its live mass, depending on several factors, such as the animal's weight and livestock practices (feeding, frequency of cleaning, etc.). Increasingly stringent standards and heightened public awareness regarding environmental issues has led to an increase in research on various treatment methods used in different countries. Among manure treatment options, organic bed biofiltration represents a very promising technique for treatment and recovery of liquid and gaseous effluent on pig farms.



The principle of biofiltration is to have liquid and gaseous effluents pass through a filter containing an organic bed. As a pollutant removal agent, the organic bed can act in two ways, as a natural resin able to fix several types of pollutants and/or as a medium for different microorganisms capable of degrading the retained substances. These pollutants are degraded into  $\text{CO}_2$  and  $\text{H}_2\text{O}$  as a result of microbial activity (10). The constituents of the organic support, particularly the lignine and the organic acids, contain many polar functional groups: alcohols, phenols, aldehydes, ketones, acids and ethers. This polar character provides a good adsorption capacity for the organic molecules and transition metals (11). Adsorption properties can also be linked to the presence of a porous structure, conducive to physical adsorption (12).

Different studies have been carried out on the use of organic beds, mainly peat, to control water pollution (13, 14). The first research work on the use of organic bed biofilters for purifying air contaminated by foul air can be traced back to Bohn (15), Zeizig (16) and Rand et al. (17). In these studies, organic bed biofilters were proved effective in reducing the polluting load of liquid and gaseous effluents at less cost than conventional technologies.

Research carried out at the Centre de Recherche Industrielle du Québec (CRIQ) has also proven that organic bed biofiltration can be used in treating highly concentrated effluent. Pilot biofilters were able to effectively treat the leachate of dairy cattle manure compost (around 9000 mg  $\text{O}_2/\text{L}$  in  $\text{BOD}_5$ , 1200 mg/L in TKN). Anaerobic phases followed by an aerobic treatment were able to remove 90% of the  $\text{BOD}_5$ , 80% of the SS and 70% of the TKN (18). Research work by Buelna et al. (19), Dubé et al. (20) and Blais (21) show that it is possible to reduce the polluting load of pig manure by more than 90% using organic bed biofiltration. The organic bed used as a filter medium increased TKN concentrations threefold and  $\text{P}_{\text{tot}}$  concentrations eightfold (20).

Biofilters succeeded in deodorizing over 95% of the offensive odour in foul air (22). Figure 2 illustrates how the BIOSOR™-MANURE operates, simultaneously treating liquid and gaseous effluents.

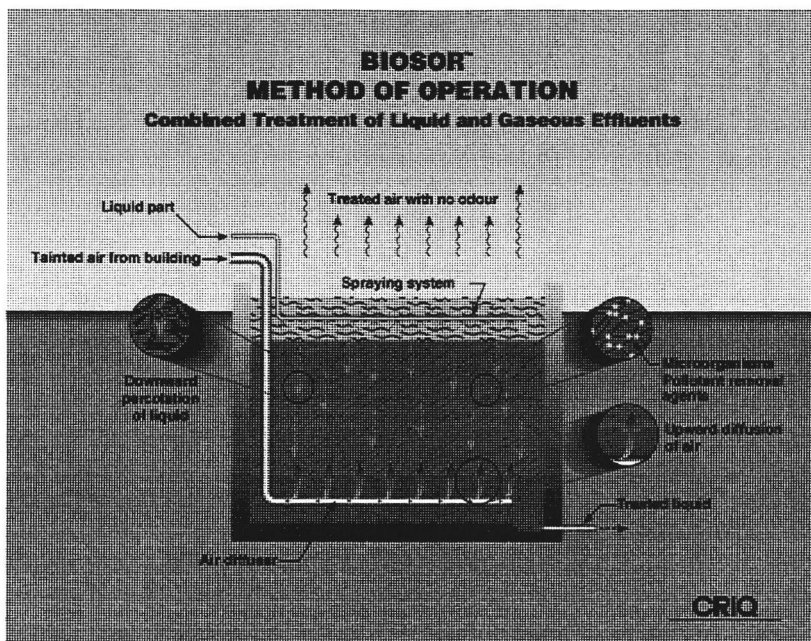

*Figure 2*  
*The BIOSOR™-MANURE technology*

Considering this technology's potential, industrial-scale research and development has been carried out to prove that the BIOSOR™ process is effective in treating pig manure and foul air in farm buildings. This work was recently done on-site at a livestock farm using a 400 m<sup>3</sup> industrial biofiltration system. The system consists of a combined decanter-digester, a protective prefilter and a double-action biofilter.

The system performed well despite variations in temperature and organic load at the manure pretank outlet. Despite strong variations in BOD<sub>5</sub> (10,000 - 20,000 mg/L), in SS (10,000 - 20,000 mg/L), in TKN (2000 - 3800 mg/L) and in P<sub>tot</sub> (500 - 900 mg/L), the BIOSOR™ system was able to maintain an overall pollutant removal performance averaging > 95% for the BOD<sub>5</sub>, > 97% for the SS, > 75% for the TKN and > 87% for the P<sub>tot</sub>. By reducing the raw manure's organic load by more than 95%, BIOSOR™ eliminates close to 95% of the odours produced when the manure is transported, stored and spread.

NH<sub>3</sub> and H<sub>2</sub>S contents in the farm production buildings vary respectively from 1.0 to 7.1 ppm and from 0.03 to 0.21 ppm, depending on the season. The biofilter installed at the pig farm and operating at a rate of 7000 m<sup>3</sup>/h can treat 94 to 100% of the ammonia present in the gaseous effluent. The treatment is 100% effective in treating hydrogen sulphide. Olfactory measurements indicate that the biofiltration treatment of gaseous emissions clearly reduces odour intensity.

An effective, simple and safe system able to control odours is a major asset in reducing the problem of surplus manure and transportation costs. By increasing the acceptability rate of the manure, more of the surplus can be managed inside the maximum economic distance for transportation and spreading (23).

## 2. Materials and Methods

An industrial biofilter system was designed, built and started up in January 1997, to treat the liquid and gaseous effluents of a pig farm with 150 sows, nursery to finish (around 2000 pigs produced/year). The system was designed to treat up to 12 m<sup>3</sup>/d of manure and 15,000 m<sup>3</sup>/h of foul air.

Figure 3 illustrates how the pig manure is first treated by separating liquid and solid fractions in a 1200 m<sup>3</sup> combined decanter-digester (a refitted storage tank). The settled sludge, representing 15 to 20% of the total volume of manure produced, is stabilized and deodorized by anaerobic digestion. The residual liquid fraction (80 to 85%) is directed to an 8-m<sup>3</sup> protective prefilter, made up of coarsely textured natural materials. Next, this fraction is pumped to the surface of a 400-m<sup>3</sup> biofilter composed of a multi-layer organic bed (wood chips, peat and bark). To meet current regulations, the treated manure is stored in an existing tank before being used as washwater or for irrigation purposes. The foul air of the production building is simultaneously directed toward the biofilter base where it undergoes a backflow treatment.

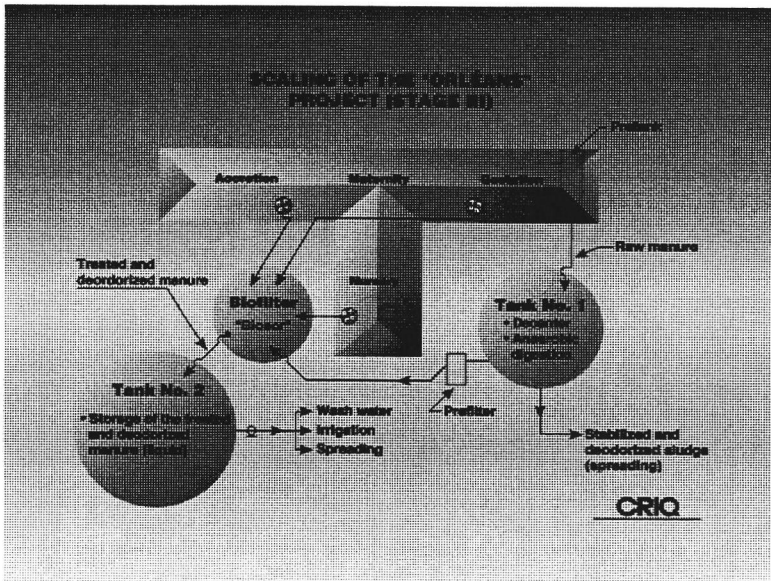

Figure 3  
Scale-up of the BIOSOR™-MANURE process

Several physical, chemical, microbiological, sensory and hydrodynamic parameters were monitored over several months to assess the biofilter's performance and working order. The biochemical oxygen demand ( $BOD_5$ ), suspended solids (SS), total Kjeldahl nitrogen (TKN) and phosphorous ( $P_{tot}$ ) were measured to establish the effectiveness of the biofiltration system in treating pig manure. Ammonia ( $NH_3$ ), hydrogen sulphide ( $H_2S$ ) and a sensory evaluation (olfactometric) were selected as parameters to establish the biofilter's pollutant removal rate for the foul air of the production building. The solid fraction (sludge) was characterized for the following parameters: water content, bulk density, organic matter, nitrogen, phosphorous and potassium.

All the analysis techniques that were used to characterize the liquid fraction of the pig manure conform with standard recommended practices (24). Sludge analyses were conducted at CRIQ's laboratory, which is accredited by the ministère de l'environnement et de la faune du Québec (MEF). The sampling method to characterize the foul air of the production building used a device to selectively sample families of compounds (25). This technique consists of trapping volatile compounds so they can be measured by specific reagents. The trapped ammonia in the form of ammonium ions in the chlorhydric solution is measured by colorimetry using a Nessler reagent according to the AFNOR NFT 90 15 standard. As for the sulphur compounds, they are measured with an iodometric test.

To conduct the sensory analysis of the treated or untreated gaseous effluent, a technique of sampling by adsorption on a piece of fabric is used. The fabric having adsorbed the odours undergoes an organoleptic evaluation. A panel of 10 to 12 people uses their sense of smell to conduct the olfactometric analysis.

The results of the sensory tests are processed according to a statistical method: the triangle test. This method, described by Larmond (26), is used to determine whether appreciable differences exist between two types of samples (tainted air/treated air and treated air/control air). Results are expressed in degrees of significance. If a difference is established, the overall effectiveness of the deodorization process is then calculated in terms of odour intensity (OI) and odour nuisance rating (ONR).

### **3. Results and Discussion**

#### **Characteristics of pig manure**

The average physical, chemical and biochemical characteristics of the effluent at the pretank outlet can be seen in Table 1. These results show an effluent with high concentrations of phosphated ( $P_{tot}$ ) and nitrogenated (TKN) organic matter ( $BOD_5$ ) and suspended solids (SS). The values obtained were from 60 to 100 times higher

than those reported for domestic sewage, which is normal for effluent from a pig farm.

The first stage of treatment is to pass the manure through the decanter-digester with the aim of neutralizing the variations in load, reducing the concentration of suspended solids and stabilizing the decanted sludge by anaerobic digestion. Table 1 shows that the decanter-digester maintained a relatively constant concentration of the different parameters as well as reducing SS concentrations by 94% and total phosphorus by 71%. As will be seen further on, this represents an advantage both in terms of manure management (reduction of transportation costs, conservation of the agronomic value) and in terms of the biofilter's operation.

Parameters (mg/l)	Raw manure mg/l (variation) average	Manure after decantation mg/l (variation) average	Average effectiveness of decantation (%)
BOD <sub>5</sub>	(10,000-20,000) 13,000	(7,200-9,600) 8,500	35
SS	(10,000-20,000) 16,000	(730-1,600) 940	94
P <sub>tot</sub>	(500-900) 650	(180-200) 190	71
TKN	(2,000-3,800) 2 300	(1,600-1,800) 1,700	26

Table 1

*Physical, chemical and biochemical characteristics of the raw manure and after decantation*

### **Simultaneous Treatment of Manure and Foul Air by Biofiltration**

#### **Treatment of the liquid fraction of the pig manure after decantation**

The pollutant removal performance of biofiltration was established using a manure flow of 7 m<sup>3</sup>/d and a ventilation rate of 7 000 m<sup>3</sup>/h. Figure 4 shows the results obtained for pH, SS, BOD<sub>5</sub>, TKN and P<sub>tot</sub>. It is important to note the consistency and quality of the performances of the biofiltration system throughout the entire experimental period. The adsorption, absorption and cationic exchange properties of the organic bed allow the system to support wide variations in load without a noticeable impact on its pollutant removal rates.

The pig manure's pH remained almost neutral throughout the experimental period. The organic bed used proved to be an effective buffer for discharging effluent with a pH of 8.

The elimination of organic carbon is not very sensitive to wide variations in the pig manure's BOD<sub>5</sub> (7,200 - 9,600 mg/L). Figure 4 shows that the biofilter's average pollutant removal rate was around 95%. The drop in effectiveness seen on day 40 and day 70 can be attributed to a lower air flow rate from the production building.

The SS concentration at the biofilter inlet varied greatly during our experiments. These variations were linked to the hydraulic behaviour of the decanter-digester. Despite heavy peak loads (~ 1 600 mg/L), elimination rates maintained SS in the

effluent at concentrations of under 200 mg/L (> 80% effectiveness). Two maintenance sessions a year (cleaning and stirring the bed) are necessary to backflush and declog the organic bed.

High TKN concentrations were detected in the pig manure. Despite peaks of 1,800 mg N-TKN/L, effluent concentration in the biofilter remained under 500 mg N-TKN/L, an average effectiveness rate of 75%. The drop in effectiveness on day 40 and day 70 was also linked to a lower air flow rate from the production building.

Although most earlier research reports only a low phosphorous up-take, Figure 4 shows that during our experiments, the average reduction in  $P_{tot}$  was on average 80%. Performances were such that they maintained  $P_{tot}$  concentrations of less than 50 mg  $P_{tot}$ /L in the effluent.

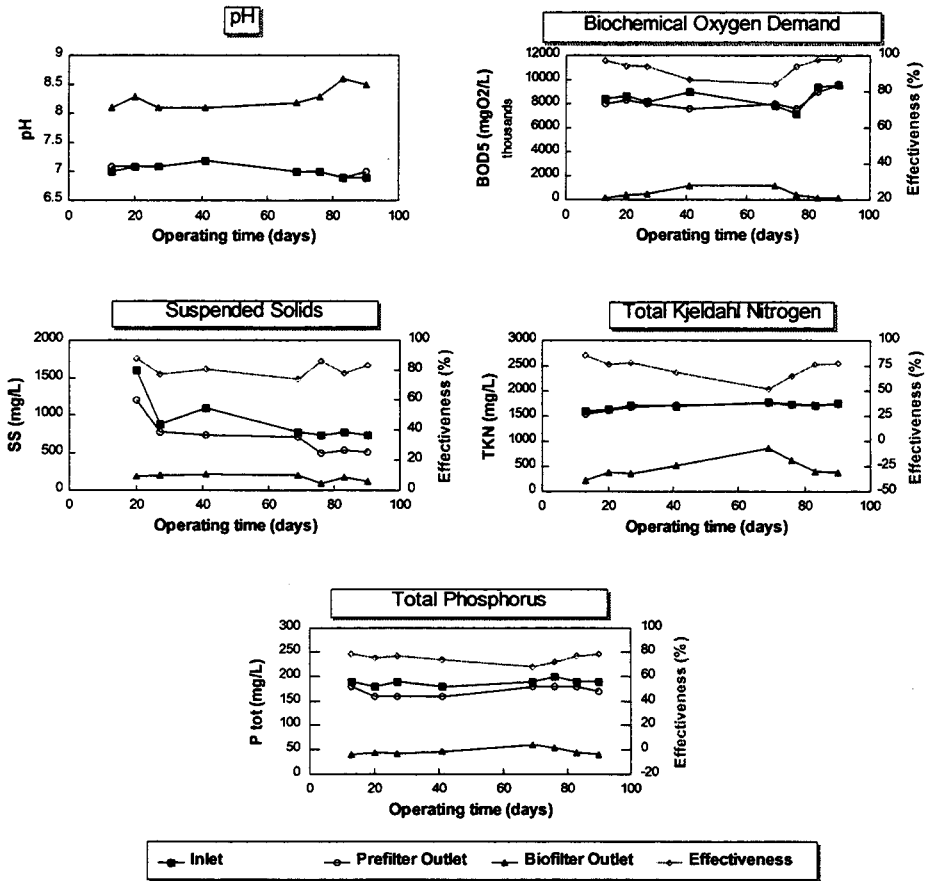
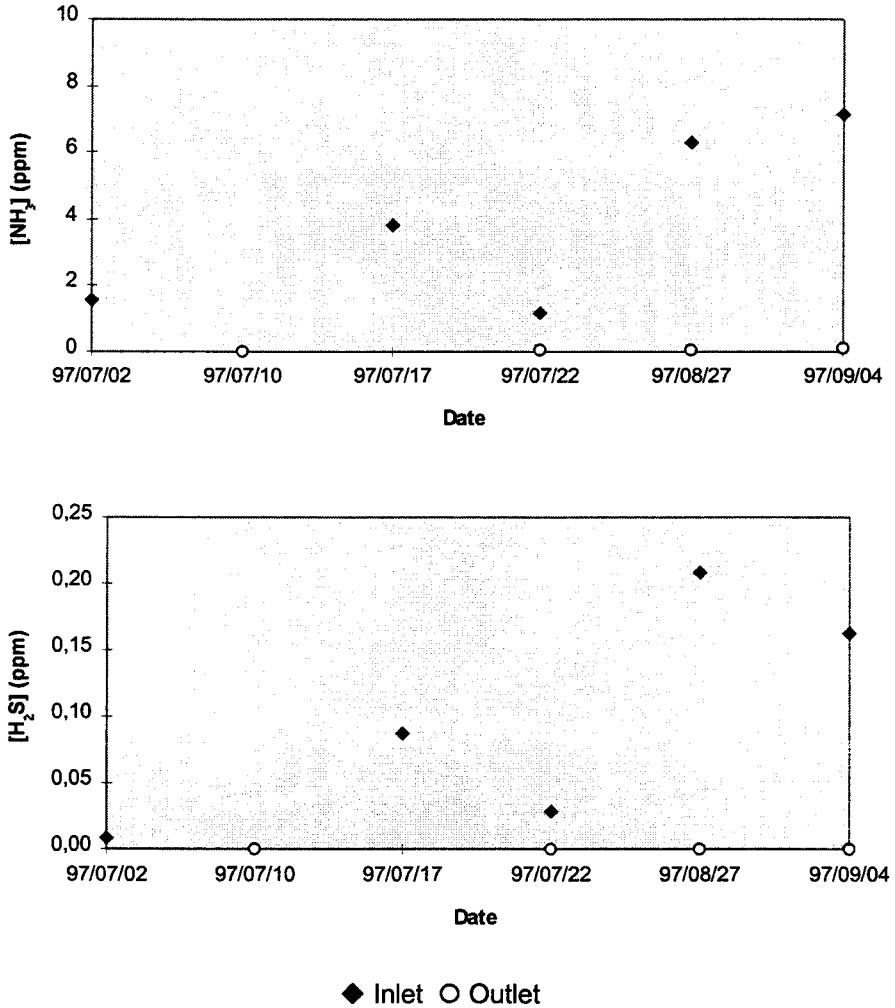

Figure 4  
Pollutant removal performance of the BIOSOR™-MANURE treatment system

## Treatment of foul air from the production building

The graphs in Figure 5 show the overall results obtained for ammonia and hydrogen sulphide concentrations in the pig farm air before (inlet) and after (outlet) biofiltration.



*Figure 5*  
 *$\text{NH}_3$  and  $\text{H}_2\text{S}$  concentrations at the biofilter's inlet and outlet over time*

The increase in concentrations at the biofilter's inlet observed at the end of the summer was caused by a decrease in ventilation of the ambient air of the pig farm. This operation is done to meet criteria regarding air flow rate in winter. This air flow is transferred entirely to the ventilators that supply the biofilter.

Ammonia is the main compound with concentrations varying between 1.0 and 7.1 ppm. H<sub>2</sub>S concentrations measured in the pig farm air (from 0.03 to 0.21 ppm), even if they seem low, nevertheless exceed the odour threshold for this compound (25).

The system's pollutant removal effectiveness varies from 94 to 100% for ammonia. As for the H<sub>2</sub>S, it was not possible to detect in the air at the biofilter's outlet. The system therefore performs very well, despite the increase in the concentrations of pollutants.

Sensory evaluation results show a marked difference between the foul air and treated air. This difference was due in large part to the intensity of the odour smelt and the degree of discomfort experienced by the panel. Figure 6 illustrates that the ambient air of the pig farm is characterized by moderate to strong intensity and is qualified as very unpleasant. The air leaving the biofilter causes a slight olfactory sensation qualified as very tolerable. The biofilter's effectiveness in terms of odour reduction was not influenced by the variations in load observed.

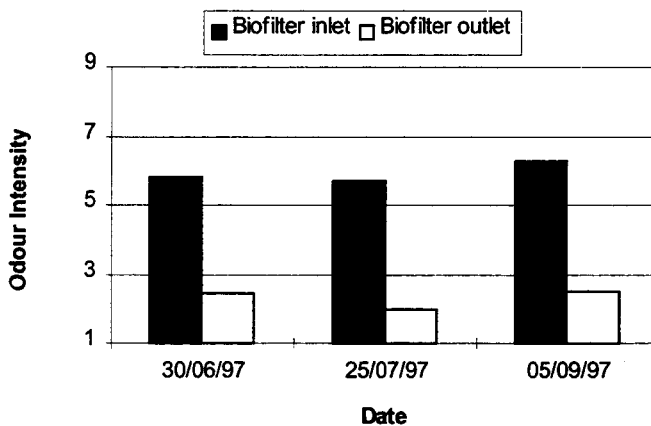



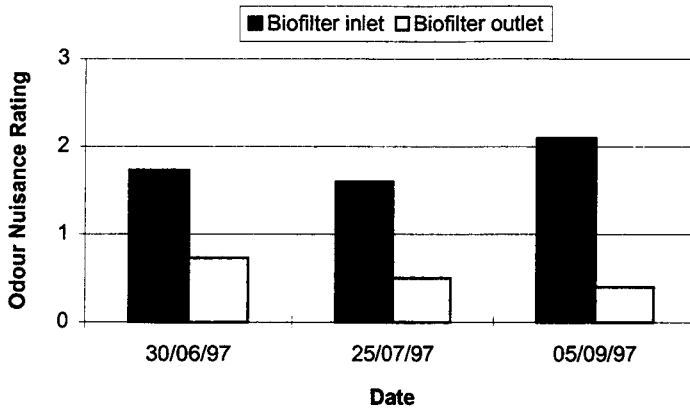

*Figure 6*  
*Odour intensity and concentration of gases at the biofilter's inlet and outlet*

In addition, the air leaving the biofilter is described as having damp earth smell (the characteristic odour of peat). The biofilter's role is therefore twofold: it degrades the pollutants from the pig farm ( $\text{NH}_3$  and  $\text{H}_2\text{S}$ ) and provides a pleasant smell to the gaseous flux.

### Recovery of decanted sludge

The fertilizing value of pig manure is conserved in the form of a semi-liquid sludge, deodorized and stabilized by anaerobic digestion. This sludge represents only 15% to 20% of the total volume of the manure to be spread, which considerably reduces the costs of transportation associated with spreading. Among other things, Table 2 shows that the characteristics of this sludge are highly appreciated for agricultural use. It contains 77% organic matter, 3.8% total nitrogen, 2.1% total phosphorus and 0.9% total potassium. No salmonella and a significant reduction in faecal coliform were also observed in the digested sludge.

Parameters	Value
Water content (%)	89
Organic matter	77
C/N	10.2
pH	6.8
Bulk density (kg/m <sup>3</sup> )	1030
Total nitrogen	4.3 (3.8%)
Total phosphorous	2.4 (2.1%)
Total potassium	1.0 (0.9%)

*Table 2*  
*Characterization of the decanted sludge of the pig manure*

Note: The organic matter content is expressed in % on a dry basis.  
 Total nitrogen, total phosphorus and total potassium contents are expressed in kg/m.t. on a wet basis and the results in parenthesis are in % on a dry basis.

## 4. Conclusion

This project's results show that the organic bed biofiltration process (BIOSOR™) is a very promising biological alternative to treat and recover the liquid and gaseous effluents from pig farms. Indeed, the BIOSOR™ technology is a process that treats pig manure globally. It reduces the polluting load of pig manure by more than 90% and eliminates close to 95% of the odours coming from buildings, storage, transportation and spreading. The BIOSOR™ system is installed directly at pork producers without modifying their production practices. It enables existing storage installations to be recuperated.

Pig manure is a waste product with high concentrations of phosphated and nitrogenated organic matter and suspended solids. Moreover, it is characterized by wide variations in load and foul odours. The values obtained are 60 to 100 times greater than those for domestic sewage.

Studies of the pollutant removal rates show that the BIOSOR™ system performed well despite variations in temperature and organic load of the liquid fraction of the pig manure. Despite wide variations of BOD<sub>5</sub> (10,000 - 20,000 mg/L), SS (10,000 - 20,000 mg/L), TKN (2000 - 3800 mg/L) and P<sub>tot</sub> (500- 900 mg/L), the BIOSOR™ system maintained overall average pollutant removal rates of > 95% for the BOD<sub>5</sub>, > 97% for the SS, > 75% for the TKN and > 87% for the P<sub>tot</sub>. The treated manure can be used as washwater for the manure recuperation systems from the buildings, as irrigation water or it can be discharged into a disposal field.

Measuring programs showed that ammonia (NH<sub>3</sub>) and hydrogen sulphide (H<sub>2</sub>S) contents in the pig farm production buildings vary respectively from 1.0 to 7.1 ppm and from 0.03 to 0.21 ppm depending on the season. The biofilter installed in the pig farm and operating at a flow of 7000 m<sup>3</sup>/h can treat from 94 to 100% of the ammonia present in the gaseous effluent. This treatment is 100% effective for hydrogen sulphide.

The results of olfactometric evaluations indicate that there is a noticeable difference between the foul air and the treated air. The untreated air is perceived as being unpleasant while the treated air is judged as tolerable. The treatment by biofiltration of gaseous emissions gives a very marked reduction in odour intensity.

The decanted and stabilized sludge, which represents 15 to 20% of the total volume of manure to spread, preserves its fertilizing value. Analyses of the sludge show very promising characteristics for agricultural recovery of the product (77% of organic matter, 3.8% of TKN, 2.1% of P<sub>tot</sub> and 1% of K<sub>tot</sub> on a dry basis). Moreover, no salmonella and a significant reduction in faecal coliform were observed. The characteristics of the stabilized sludge and the reduction of transportation costs associated with spreading will no doubt contribute to increasing the manure acceptability rate within economic distances.

In light of these results, there is no doubt that the BIOSOR™ process is a sound, simple and effective technique that provides a global solution to the environmental problems associated with manure management. This technology now makes it possible to reconcile people's environmental concerns with the pork industry's potential for growth.

## 5. Acknowledgements

This work was made possible due to the financial contribution of the Conseil de recherches en pêche et en agroalimentaire du Québec (CORPAQ - MAPAQ), of the coopérative fédérée du Québec, of the Fédération des producteurs de porcs du Québec (FPPQ), of Génétique NPD (Québec) inc., of the ministère de l'agriculture des pêcheries et de l'alimentation du Québec and of the porcherie Orléans inc. The authors would also like to thank Bel Environnement inc. for its technical support during this project.

## 6. References

- (1) **Thériault J.** 1987. Étude sur la composition et la valeur monétaire du cheptel animal au Québec, MAPAQ, 92 p.
- (2) **Buelna G., Caouette P., Pigeon S.** 1993. Désodorisation des lisiers: étude comparative des principales technologies existantes selon une approche intégrée. Sciences et techniques de l'eau, Vol. 26, no 4: 243-252
- (3) **Lee R.E.** 1976. Air pollution from pesticides and agricultural processes, CRC Press inc., Ohio, USA.
- (4) **Mcquitty J.B., Maclean A.J.** 1983. L'effet du fumier dans l'environnement canadien, CNRC, n° 18977, Ottawa, Canada.
- (5) **Lasbleiz M.** 1989. Étude des procédés physico-chimiques d'épuration du lisier de porc, Université de Rennes I, thèse n° d'ordre 366, France.
- (6) **Apsimon H.M., Kruse-Plass M.** 1990. The role of ammonia as an atmospheric pollutant, Odor and ammonia emissions from livestock farming, Elsevier applied science, London, UK.
- (7) **Hartung J.** 1990. Odor and ammonia emissions from livestock farming, Elsevier applied science, London, UK.

- (8) **Pain B.F., Misselbrook T.H.** 1990. Relationships between odor and ammonia emission during and following the application of slurries to land, Odor and ammonia emissions livestock farming, Elsevier applied science, London, UK.
- (9) **Roche** 1984. Amélioration et démonstration du procédé de compostage du lisier de porc. Environnement Canada, 214 p.
- (10) **Bélanger, A., Potvin, D., Cloutier, R., Caron, M. and Thériault G.** 1987. La tourbe: Une ressource d'avenir. Étude réalisée pour le Centre québécois de valorisation de la biomasse, 125 p.
- (11) **Coupal, B. and Lalancette, J.M.** 1976. The treatment of wastewaters with peat moss. Water Research, Vol. 10, 1071-1076.
- (12) **Tinh, V.Q., R. Leblanc, J.M. Janssens and M. Ruel.** 1971. Peat moss - A natural adsorbing agent for the treatment of polluted water. Can. Min. Metall. Bull. Vol. 64, 99-104.
- (13) **McLellan, J.K. and C.A. Rock.** 1986. The application of peat in environmental pollution control: a review. International Peat Journal. Vol. 1, 1-14.
- (14) **Couillard D.** 1994. The use of peat in wastewater treatment. Water Research, Vol. 28, N° 6, 1261-1274.
- (15) **Bohn, H.L.** 1975. Soil and compost filters of malodorant gases. J. Apca, Vol. 25:9, 953-955.
- (16) **Zeizig, H.D., Kreitmeier, J. Franzpeck, J.** 1977. Schriftenreihe der Landtechnik. Weihenstephan (HHrsg), I..
- (17) **Rand, M.B., Cooper, D.E., Woo, G.O., Fletcher, T.C. and K.A. Roife.** 1981. Compost filters for H<sub>2</sub>S removal from anaerobic digestion and rendering exhausts. JWPCF, 53;2, p. 185-189.
- (18) **Lessard, R., Buelna, G. and Lessard, P.** 1994. Traitement d'un lixiviat de compost de fumier de bovins laitiers par biofiltration anaérobie et aérobie sur milieu organique. 17e Symposium international sur le traitement des eaux usées. A.Q.T.E. Montréal, November.
- (19) **Buelna G., Dubé R., Lessard P., Cotte F., Gracian C., Fanlo J.L.** 1997. Désodorisation du lisier de porc par le procédé de biofiltration sur support organique BIOSOR<sup>MC</sup>. 4<sup>e</sup> Congrès international sur la caractérisation et la réduction des émissions d'odeurs et de COV. APCAS/AWMA, Montréal, Québec, Canada, Octobre.

(20) **Dubé, R., Buelna, G. et Lessard, P.** 1995. Traitement du lisier de porc par biofiltration sur milieu organique aéré. 18e Symposium international sur le traitement des eaux usées. A.Q.T.E. Montréal, Novembre.

(21) **Blais, P.** 1996. Traitement du lisier de porc par biofiltration et lit absorbant sur milieu organique. Mémoire de maîtrise. Université Laval, Sainte-Foy, Québec.

(22) **Buelna G., Bouchard M.C., Kowal S. Lessard P.** 1993. Traitement simultané des effluents liquides et gazeux par le procédé BIOSOR<sup>MC</sup>, CRIQ, 640-PI07900-11.

(23) **Consultants BPR.** 1990. Analyse de la situation des surplus de lisiers et proposition d'une structure de gestion, MENVIQ-MAPAQ, 60 p.

(24) **American Public Health Association, American Water Works Association and Water Pollution Control Federation.** 1989. Standard methods for examination of water and wastewater. 17th ed. Washington, D.C.

(25) **Le Cloirec P., Fanlo J-L, Degorce-Dumas J.R.** 1991. Traitement des odeurs et désodorisation industrielle, Innovation 128 Ed. Paris.

(26) **Larmond E.** 1979. Méthodes d'appréciation sensorielle des aliments en laboratoire, Centre d'édition du gouvernement du Canada, Ottawa, Canada.

G :envirolconferen.ce\baqtea.doc

## **Biogas production in agriculture: safety guidelines, cofermentation and emissions from combined heat and power couplings**

*Production de biogaz en agriculture : recommandations de sécurité,  
cofermentation et émissions issues du couplage chaleur et puissance.*

**Amon Thomas, Boxberger J., Lindworsky J., Scheibler M.**

Institute Landtechnik. Universitat F. Bodenkultur.

Nussdoreer Lande 29-31. 1190 Wien. AUSTRIA

E-mail : Kiesslin@edv2.boku.ac.at

### **Abstract**

*Biogas production is an effective means for improving the efficiency of slurry utilisation. It has several positive effects : energy gaining from a renewable source, reducing of methane emissions during slurry storage, improving the nitrogen availability after spreading of the slurry.*

*The number of agricultural biogas plants increases continuously. There is a shortage of documets for constructing biogas plants and of saftey guidelines. At the moment there are no standardized guidelines available for planning and building of biogas plants. Those guidelines would be necessary to guarantee a saftey operation and cost effective building of biogas plants as well as for authorizing procedures. The ILUET is developing technical standards for the different components of biogas plants. Those standards are currently realized on several farms.*

*The cofermentation of agricultural wastes together with non agricultural wastes is of growing interest, because the conditions for biogas production and cofermentation have recently improved. There is little knowledge on the influence of composition of the organic wastes, of the relation from organic wastes to agricultural wastes on the biogas yield, biogas quality and on the stability of the digester operation.*

*Investigations deal with the course of biogas yield and composition depending on different cofermentation substrates. Results show that the biogas yield doubles, when 10% of fat are added to slurry from milking cows. From 30% of cofermentation substrates onwards the biogas yield does not increase anymore but the stability of the digester decreases. Therefore the percentage of organic wastes should not exceed 30%. All positive effects of cofermentation can be used. The cycle of the organic wastes is of manageable size which helps to control the quality. Many agricultural farms can use the positive effects of cofermentation.*

*Biogas is converted to electricity and heat by combined heat and power coupling. Exhaust fumes from combustion engines, that are run with biogas, contain air polluting substances : HC, SO<sub>2</sub>, NO, NO<sub>2</sub> and CO e.g. The emissions depend on the composition of the biogas, which is not constant. There is only knowledge on the emissions from combustion engines used in agricultural biogas plants.*

*Influences on the amount of emissions of air polluting substances from biogas combustion engines and on the efficiency factor of the engine are to be found : quality of biogas, exhaust fume cooling, biogas to air relation, lean concept. Combustion engines of different power levels and design are investigated. From the results proposals for means to reduce the emissions are derived. Biogas combustion with a little oxygen surplus ( $\lambda > 1,3$ ) is at the moment the most cost-effective means to reduce NO<sub>x</sub> and CO emissions. Construction and operation technique means should be aimed to enable the engine to work in the lean range ( $\lambda > 1,3$ ).*

Keywords : biogas production, cofermentation, exhaust fume emissions.

## **Résumé**

La production de biogaz est une mesure efficace pour améliorer l'utilisation des lisiers. Cette technique présente de nombreux avantages tels que l'économie d'énergie à partir d'une ressource renouvelable, la réduction des émissions de méthane au cours du stockage et l'amélioration de la disponibilité en azote lors de l'épandage des lisiers.

Le nombre d'unités de méthanisation en milieu agricole augmente régulièrement sans qu'il existe de document décrivant les recommandations liées à la construction et à la sécurité de ces installations.

La cofermentation de déchets agricoles avec des déchets non agricoles est une option qui se développe bien qu'il reste à améliorer les connaissances sur la composition de ces déchets organiques et leur lien avec le rendement en biogaz et la qualité du biogaz produit ainsi que sur le fonctionnement des unités.

Nos résultats ont par exemple démontré que le rendement en biogaz était doublé lorsque l'on ajoute 10% de graisses à du lisier vaches laitières.

Le biogaz est converti en électricité et chaleur. Les fumées qui s'échappent des appareils de combustion contiennent des polluants atmosphériques tels que SO<sub>2</sub>, NO, NO<sub>2</sub> et CO. Ces émissions dépendent de la composition du biogaz brûlé qui n'est pas constante.

La combustion du biogaz avec un léger excès d'oxygène ( $\lambda > 1,3$ ) est à présent la méthode la plus efficace et la moins coûteuse pour réduire les émissions de  $\text{NO}_x$  et  $\text{CO}$ .

Mots-clés : production de biogaz, cofermentation,

## 1. Introduction

In Austria 18 Mio t/a of agricultural manures and 8 Mio t/a of organic wastes can be used for an energy production of about 2700 GWh/a. The number of agricultural biogas plants continuously increases. If all of the agricultural manures and organic wastes that are suitable for biogas production should be used for anaerobic digestion, 13000 to 46000 biogas plants would be necessary depending on the size of the biogas plants. Cofermentation of agricultural manures and organic wastes can reduce  $\text{CO}_2$  emissions by 3 Mio t  $\text{CO}_2$ /a. For the building and the operation of the biogas plants about 13000 working situations are required (AMON 1998).

## 2. Technical Standards for Biogas Plants

Standardised guidelines would be necessary to guarantee a safety operation and cost effective building of biogas plants as well as for authorising procedures. The ILUET is developing technical standards for the different components of biogas plants. Those standards are currently realised on several farms.

Figure 1 gives an overview over the components of a typical agricultural biogas plant. Agricultural manures and organic wastes are collected, mixed and if necessary chopped in the preparation pit. Isolated concrete tanks with underfloor heating and vertically and horizontally adjustable mixers are common digesters for agricultural biogas plants. Horizontal steel tanks with heated mixer and mud outlet are also used. They are most suited for fermentation of substrates with a high dry matter content. Because biogas production can still be observed in the *effluent storage*, it should also be integrated in the gas bearing system. The *sulphur removal* from the biogas can be done by blowing small amounts of air (max. 4% of the biogas quantity) on the surface of the substrate in the digester or in the secondary fermentation tank. Biogas is then desulphurized by micro-organisms.

The *gas reservoir* has to be gas tight, durable, pressure and temperature resistant. Flexible gas storages must be shielded from weather, UV light and mechanical damages by a housing. Agricultural biogas plants are always operated with low pressure in the *gas bearing* system ( $< 100$  mbar, usually 2-5 mbar). The operating pressure is guaranteed by a pressure safeguarding, which also serves as a *condensate separator*. The gas bearing system has to be corrosion and mechanical



resistant. The gas line must have a slope of at least 1% to let the condensation water drop out.

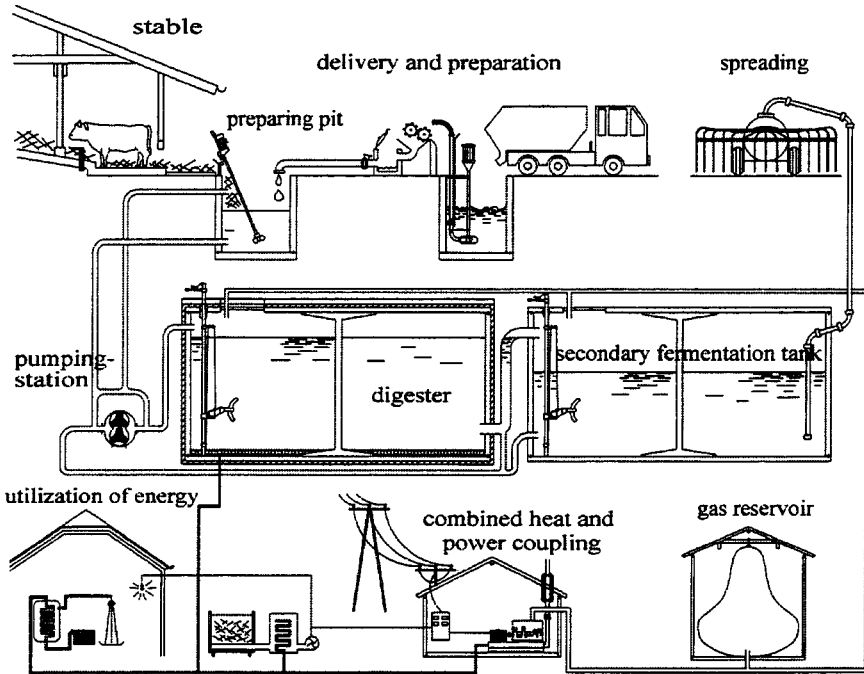

Figure 1.  
Model of a typical agricultural biogas plant (AMON ET AL. 1997)

The *engine room* contains the combined heat and power coupling. Its door must be fire resistant and must open to the outside. At the entrance a gas shut off has to be installed, that switches off the combined heat and power engine. The combined *heat and power coupling* should meet the following demands: supervision of oil pressure and water temperature, sound proofing and vibration damper, collection of oil losses and fume line to the outside. The combined heat and power coupling should easily be accessible for operation and maintaining.

### 3. Cofermentation

Cofermentation of organic wastes and agricultural manures increases the biogas yield and offers an environmentally friendly alternative to landfilling of organic wastes. However amount and quality of the added organic wastes have to be carefully watched to guarantee a safety operation of the biogas plant and a good biogas quality. Therefore it is necessary to have figures on the amount and composition of organic wastes that are added to agricultural manures as well as on

the hydraulic residence time that is needed to guarantee a sufficient degradation of the organic matter.

Two biogas plants have so far been investigated. Both biogas plants had heated digesters with vertically and horizontally adjustable mixers. The digester of biogas plant A had a size of 450 m<sup>3</sup>, a temperature of 55°C, a mean hydraulic residence time of 75 days and a heated but not isolated secondary fermentation tank (1000 m<sup>3</sup>). On biogas plant B biogas was collected from a digester of 150 m<sup>3</sup> with a temperature of 30-33°C and a mean hydraulic residence time of 125 days. Biogas plant A fermented 6 m<sup>3</sup>/d of cattle slurry, farmyard manure, pure fat, flotation fat and water. On biogas plant B 2 m<sup>3</sup>/d of cattle slurry were fermented with 7 l/d of pure fat and 110 l/d of food wastes.

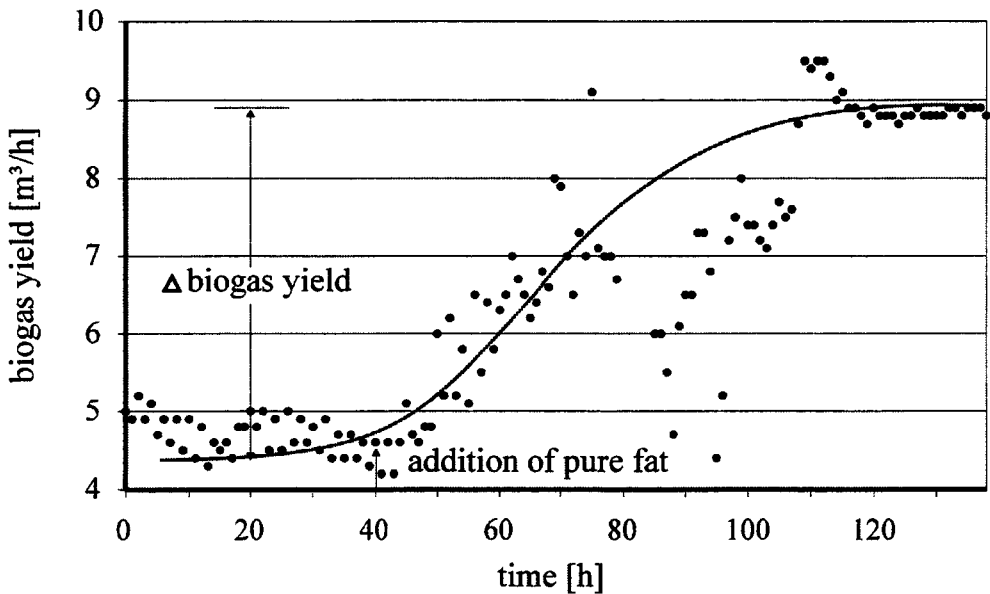

Figure 2.  
Course of biogas yield after addition of pure fat to a mixture of cattle slurry

Composition of input materials, biogas yield and biogas quality were measured. On biogas plant B 860 kg oDM of pure fat were added to 608 t oDM of fermentation substrate (80% oDM cattle slurry and 20 % oDM food wastes). The biogas yield increased immediately after the addition of fat. 60 hours later it had doubled (fig. 2). This high yield lasted for about one day, after that the biogas yield decreased again and reached its former level. After 5 days the added fat was completely degraded.

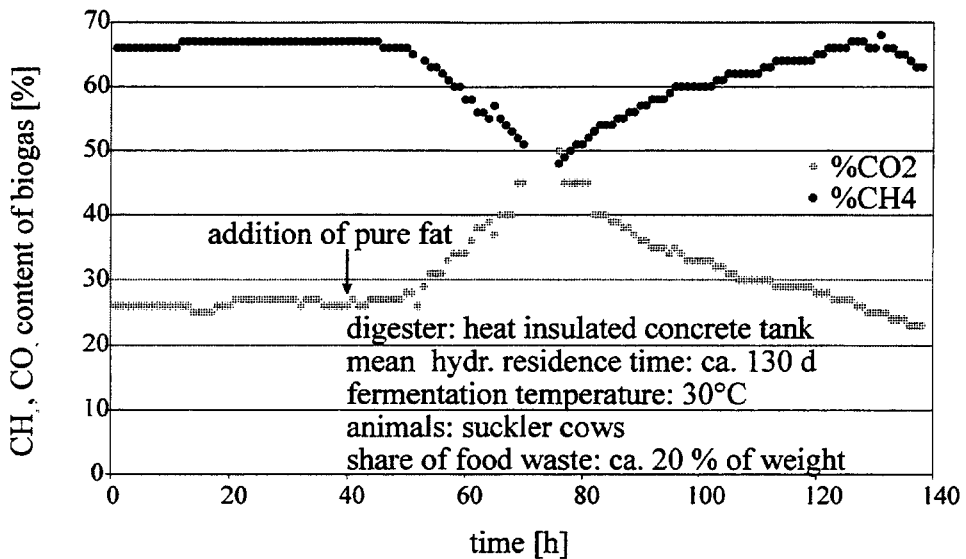

Figure 3.

Course of biogas composition after addition of pure fat to a mixture of cattle slurry.

Addition of fat also influenced the biogas composition (fig. 3). Immediately after the addition of fat the methane concentration in the biogas decreased and the CO<sub>2</sub> concentration increased. After 40 hours the methane concentration had reached its minimum and began to increase to meet its former level 90 hours after the fat addition. At the beginning of the degradation of organic matter mainly CO<sub>2</sub> is formed. CH<sub>4</sub> formation begins later in the degradation process. On the whole the fat addition resulted in an increase of the methane yield from 31.3 to 54.0 m<sup>3</sup>/h.

Table 1 shows the composition of the input material and of the substrates in the digester and in the secondary fermentation tank of biogas plant A. The hydraulic residence time was 75 days.

In the digester the oDM was degraded from 173.47 g/kg to 45.80 g/kg. This corresponds to a degradation rate of 74%. In the secondary fermentation tank the oDM was further degraded to 30.95 g/kg (= 32% degradation rate). A substantial degradation rate in the secondary fermentation tank was frequently observed (DANZINGER 1998, SCHEIBLER 1998). Therefore the hydraulic residence time in the digester and in the secondary fermentation tank should not fall below 80 days. This provides a high degradation rate, a high biogas yield and helps to avoid environmental problems that occur, if methane is formed in the storage tank and emits into the atmosphere.

ingredient	input <sup>a</sup> [g/kg] n = 22	digester [g/kg] n = 8	secondary ferm. tank <sup>b</sup> [g/kg] n = 12
DM	197.40	67.58	49.25
oDM	173.47	45.80	30.95
NH <sub>4</sub> -N	0.69	1.23	1.16
N <sub>org</sub>	4.25	3.48	2.94
pH	5.56	8.15	8.06

<sup>a</sup>calculated from the ingredients of the different substrates and their share in the fermentation substrate

<sup>b</sup>addition of 20% of flotation fat (19 g oDM/kg FM) after the digester

*Table 1.*  
*Composition of substrates of biogas plant A*

During the anaerobic digestion a part of the organic nitrogen was degraded to ammonium. The pH increased from 5.56 in the input material to 8.06 in the fermentation substrate. Those results correspond well with values given in the literature (BESSON ET AL. 1981, MESSNER 1988). Anaerobic digestion increases the fertiliser value of agricultural manures. Dry matter content in the slurry decreases. Therefore the slurry can easily be band spread with high accuracy.

#### **4. Emissions from combined heat and power couplings**

Gas-engines in combined heat and power couplings enable the upgrading of biogas to electricity and heat. Gas-Otto-engines are most common. Sporadically diesel-gas-engines are used. In agriculture engines with a relatively simple technique are employed. Engines with a large volume and a small performance density are most common. Mostly the air-to-biogas ratio is manually controlled.

There is a variety of possibilities to influence the operating behaviour of the engine, the emission level and the efficiency by technical construction or by the way of operation (fig. 4). The operating life of the engine is strongly dependent on the sulphur content of the biogas and on the maintenance of the engine. Technical details such as piston displacement, inlet and outlet port design or charge air cooling define the operation and emission behaviour and the efficiency of the engine (PISCHINGER & SCHMILLEN 1994, SCHÄFER & VAN BASSHUYSEN 1993). The air-to-biogas ratio can easily be influenced by the farmer. This measure does not cause any technical effort, but can substantially reduce the emission of air polluting substances. The efficiency of this measure is expected to be very high.

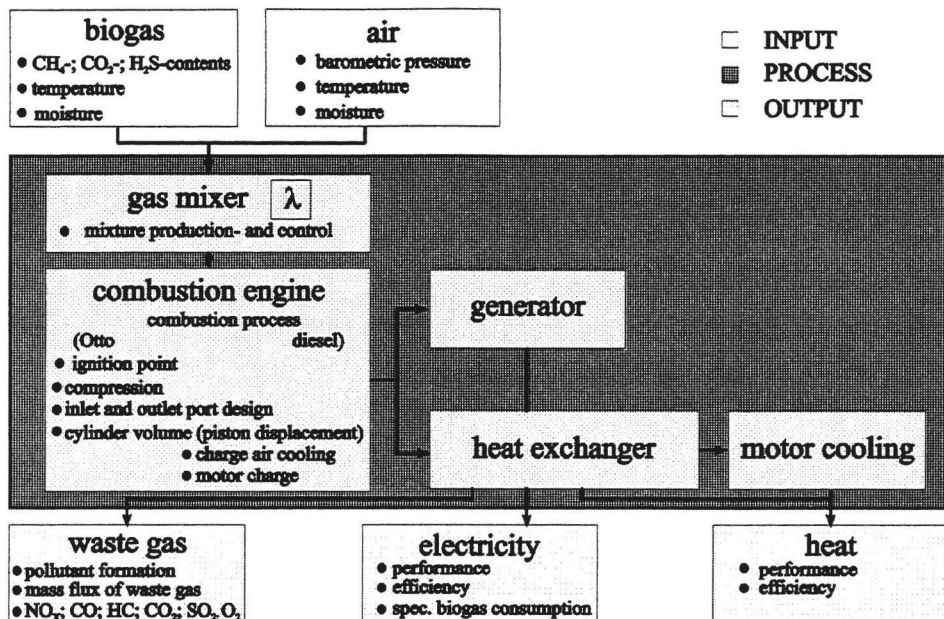

Figure 4.

Model of electricity and heat production in combined heat and power couplings.

There is little knowledge on the effect of the air-to-biogas ratio on the reduction of emissions of CO and NO<sub>x</sub> and on the biogas consumption from gas-Otto-engines that are worked with biogas. This effect is of great interest for agricultural biogas plants.

So far the experiments have been carried out with gas-Otto-engines of two biogas plants under field conditions. Table 2 shows the characteristics of the investigated gas-Otto-engines.

The air-to-biogas ratio was manually regulated. The technical outfit of the engines was simple. The biogas consumption was continuously measured near the biogas inlet into the engine. The exhaust gas was sampled immediately after the exhaust heat exchanger in the exhaust pipe of the combined heat and power coupling. After the exhaust heat exchanger the exhaust gas sample was taken from the pipe by a heated probe and was brought to the analyser by a heated gas line. NO<sub>x</sub> (NO and NO<sub>2</sub>) were measured with electro-chemical cells.

The formation of air polluting substances and the biogas consumption were determined by the air-to-biogas ratio (I). The NO<sub>x</sub>-concentration showed a clear maximum (3000 mg NO<sub>x</sub>/m<sup>3</sup>) with I = 1.1-1.2 (engine A, fig. 5). This air-to-biogas ratio offered enough oxygen for the NO<sub>x</sub> formation. The high combustion temperature also favoured the NO<sub>x</sub> formation. When I increased, the NO<sub>x</sub> content of

the exhaust gas decreased. At  $\lambda > 1.5$  it fell below  $350 \text{ mg/m}^3$ .  $350 \text{ mg/m}^3$  is the limiting value given by the Austrian order concerning the prevention of air pollution. However from  $\lambda = 1.4$  onwards ignition failures were observed. During ignition failures it is probable that the biogas is not combusted and leaves the engines uncombusted. This causes methane emissions that have to be avoided.

	Engine A	Engine B
motor parameters		
motor scheme	gas-Otto-engine (Ford)	gas-Otto-engine (Perkin-Elmer)
performance ( $P_{el}$ , [kW])	18-25	16-23
cylinder	6	4
piston displacement [l]	4.9	3.9
engine speed	1500	1500
biogas quality		
CH <sub>4</sub> [Vol.%]	55-60	58-60
CO <sub>2</sub> [Vol.%]	39-44	39-41
H <sub>2</sub> S [ppm]	35-50	40-80
biogas temperature [°C]	30-32	not measured
air temperature [°C]	30-31	27-29
atmospheric pressure [mbar]	943-950	974- 977

Table 2.  
Characteristics of the investigated gas-Otto-engines  
and the surrounding parameters

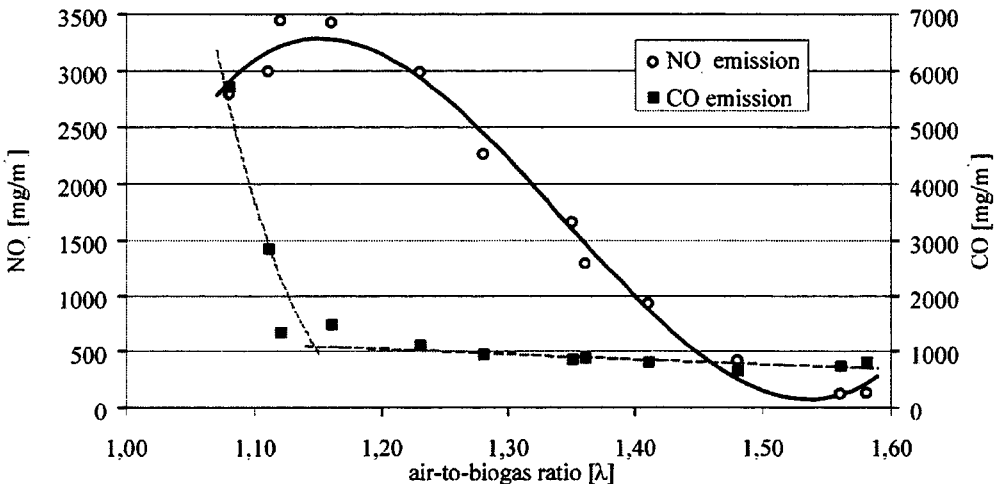

Figure 5.  
 $NO_x$  and CO concentration in the exhaust gas in dependency  
on the air-to-biogas ratio (engine A).

Engine B showed the maximum of NO<sub>x</sub> emissions (1000-1500 mg/m<sup>3</sup>) with  $\lambda = 1.5$ -1.2. From  $\lambda = 1.3$  onwards the NO<sub>x</sub> content of the exhaust gas fell below 200 mg/m<sup>3</sup>. A further oxygen surplus caused ignition failures.

CO is formed, when there is a lack of oxygen during the combustion. Figure 5 shows the CO content of the exhaust gas in dependency on the air-to-biogas ratio (engine A). As  $\lambda$  decreased, the CO formation heavily increased and reached its maximum of 6000 mg/m<sup>3</sup> at  $\lambda = 1.1$ . From  $\lambda = 1.2$  onwards the CO concentration in the exhaust gas did not substantially decrease anymore.

With engine B the CO content of the exhaust gas decreased from 7000 mg/m<sup>3</sup> at  $\lambda = 1.05$  to 500 mg/m<sup>3</sup> at  $\lambda = 1.1$ . A further oxygen surplus did not decrease the CO content. The limiting value for CO given by the Austrian order concerning the prevention of air pollution is 500 mg/m<sup>3</sup>. The results of the experiments correspond well with other emission measurements from gas-Otto-engines that were operated not with biogas but with fuel and natural gas (KUHLMANN 1994, PISCHINGER & SMILLEN 1994, SCHÄFER & VAN BASSHUYSEN 1993). Operating gas-Otto-engines with biogas therefore leads to similar emissions.

The air-to-biogas ratio also influenced the biogas consumption. With increasing  $\lambda$  the biogas consumption grew degressively. Engine A consumed 0.84 m<sup>3</sup> of biogas for the production of one kWh electricity at  $\lambda = 1.1$ . With  $\lambda = 1.5$ , 0.93 m<sup>3</sup> per kWh were needed. The biogas consumption of engine B was very similar: from  $\lambda = 1.1$  - 1.3 the biogas consumption increased from 0.7 to 1.1 m<sup>3</sup> biogas per kWh electricity. With increasing oxygen surplus the biogas consumption grows and the efficiency decreases. This means that with the engine technology that is currently employed in agricultural biogas plants the operation of the engines must find a compromise between low emission and low biogas consumption.

## 5. Conclusions and recommendations

### 1. Safety guidelines

At the ILUET technical standards for building and operation of biogas plants have been developed. They are currently realised on several farms.

### 2. Cofermentation of agricultural manures with organic wastes

Cofermentation increases the methane yield. The share of fat and other easily degradable organic substrates should be limited to a maximum of 5% of oDM to avoid instability of the biogas process. The hydraulic residence time of the fermentation substrate in the biogas plant should not fall below 80 days to guarantee the degradation of the organic substance to a high extent.

Every tank containing fermentation substrate should be integrated in the gas bearing systems to collect the methane that is built from the substrate not only in

the digester but also in the other parts of the biogas plant. The emission of methane into the atmosphere has to be avoided.

To avoid ammonia losses during and after spreading of the anaerobically digested slurry, band spreading application techniques have to be used and the fertilisation has to be done during the growth period of the plants, when there is a need of ammonium-N (BOXBERGER & AMON 1997).

### *3. Combined heat and power coupling*

With gas-Otto-engines employed on agricultural biogas plants the air-to-biogas ratio (I) substantially influences the emission of NO<sub>x</sub> and CO. However I may not exceed 1.35 to 1.4, because ignition failures occur and the methane emissions of the exhaust gas are expected to increase. If fluctuations of the biogas quality are expected, an automatic regulation of the air-to-biogas ratio can efficiently reduce NO<sub>x</sub> and CO emissions.

The biogas consumption increases with growing I. The operation of gas-Otto-engines should therefore not only consider low emissions but also low biogas consumption. With a compromise of both demands the best environmental control can be reached.

## **6. References**

[1] AMON, T. Reduktionspotentiale für klimarelevante Spurengase durch dezentrale Biomethanisierung in der Landwirtschaft. Schriftenreihe des BMUJF Nr. 26/1998, Bundesministerium für Umwelt, Jugend und Familie, Akademie für Umwelt und Energie, Laxenburg, Wien, 1998.

[2] AMON, T., GRAF, W., JÜNGLING, G., LINDWORSKY, J., ÖKL-ARBEITSGRUPPE ENERGIE. Landwirtschaftliche Biogasanlagen. Technisches ÖKL-Merkblatt Nr. 61, ÖKL, 1997.

[3] BESSON, J.-M., THALMANN, H., LEHMANN, V., ROULET, M., LISCHER, P. Güllebehandlung: Lagerung, Belüftung und Methangärung a) Wirkungen auf einige Gülleinhaltsstoffe. In Fragen der Güllerei, I. Band (1981), BAL-Gumpenstein, Hrsg., S. 29-78. Bericht über die 7. Arbeitstagung Fragen der Güllerei vom 29.09. bis 02.10.1981 in Gumpenstein.

[4] BOXBERGER, J., AMON, T. Formen der Bioenergiegewinnung - technische und ökonomische Aspekte. In Chancen regionaler Wertschöpfung (1997), Ökosoziales Forum Österreich, Hrsg., S. 181-191. Beiträge zur Wintertagung 10.-14. Februar 1997, Wien.



- [5] **DANZINGER, G.** Untersuchungen zur Cofermentation organischer Reststoffe und Schweinegülle unter praktischen Bedingungen. Diplomarbeit, Universität für Bodenkultur, Institut für Land-, Umwelt- und Energietechnik, 1998. In Vorbereitung.
- [6] **KUHLMANN, P.** VDI-Lexikon Energietechnik. VDI Verlag, Düsseldorf, 1994, S. 1076-1077.
- [7] **MESSNER, H.** Düngewirkung anaerob fermentierter und unbehandelter Gülle. Dissertation, Technische Universität München-Weihenstephan, Fakultät für Landwirtschaft und Gartenbau, Freising, 1988.
- [8] **PISCHINGER, F., SCHILLEN, K.** VDI-Lexikon Energietechnik. VDI Verlag, Düsseldorf, 1994, S. 19-21.
- [9] **SCHÄFER, F., VAN BASSHUYSEN, R.** Schadstoffreduzierung und Kraftstoffverbrauch von PKW-Verbrennungsmotoren. Springer-Verlag, Wien, 1993.
- [10] **SCHEIBLER, M.** Abbau der organischen Substanz und Biogasqualität bei der Co-Fermentation von Rinderflüssig- und -festmist mit organischen Sekundärrohstoffen. Diplomarbeit, Universität für Bodenkultur, Institut für Land-, Umwelt- und Energietechnik, Wien, 1998. In Vorbereitung.

## Using the thermophilic aerobic process to decompose industrial food wastes

*Utilisation du procédé aérobie thermophile pour la décomposition de déchets agroalimentaires industriels.*

**Juzo Matsuda**, Professor

**Takeki Maeda, Yoshiyuki Abe, Sachiko Nakamura**, Graduate Research Assistant.

**Kazuhiko Ohmiya**, Associate Professor.

Department of Agricultural Engineering,  
Hokkaido University, Sapporo, 060-8589. Japan

E-mail : [juzo@bpe.agr.hokudai.ac.jp](mailto:juzo@bpe.agr.hokudai.ac.jp)

### Abstract

*A full-scale study of the thermophilic aerobic decomposition of industrial food wastes was performed for two months in Hokkaido, Japan, using a reactor that was already in operation. The process reactor contained cedar chips, which acted as a bulking agent and water absorbent. Air was supplied through the bottom of the reactor, so that the added organic matter was decomposed aerobically. Water was evaporated by the heat generated in the reactor and the organic matter was decomposed almost completely, as it was converted into carbon dioxide, water, and minerals (ash). The process reactor is 52 m long, 6 m wide and 2.5 m deep. Cedar chips in the reactor ranged in size from 5 mm to 30 mm. A total of 924 t of organic wastes were added to the reactor from the time it was first put into operation, including 470 t of vegetable waste, 370 t of scallop waste and 80 t of squid wastes, at an average feeding rate of 7 t/day. During this study, the temperature of the reactor reached a maximum of 73 C and was generally maintained between 45 and 70 C. The moisture content of the reactor contents, including the combination of cedar chips and decomposed waste, was about 55%, and the pH of the contents was more than 8. The ash content of the reactor contents increased over time, as the waste was converted into water, carbon dioxide and ash. However, the total volume of the contents did not increase at all over time, because only the residual ash and a small amount of organic wastes remained in the reactor.*

### Résumé

Une étude grandeur réelle sur la décomposition aérobie thermophile de déchets agroalimentaires industriels a été effectuée sur une période de 2 mois à Hokkaido, Japon, sur un réacteur fonctionnant en routine. Le réacteur contient des copeaux de cèdre qui jouent le rôle d'agent de texture et d'absorbant de l'humidité. L'air est insufflé par la base du réacteur ; ainsi la matière organique ajoutée à celui-ci est décomposée par voie aérobie. L'eau est évaporée par la chaleur produite dans le

réacteur et la matière organique est entièrement décomposée, en CO<sub>2</sub>, H<sub>2</sub>O et matières minérales (cendres). Les dimensions du réacteur sont 52 m (longueur), 6 m (largeur) et 2,5 m en profondeur. Les copeaux de cèdre dans le réacteur sont de taille variable allant de 5 mm à 30 mm. Un total de 924 t de déchets organiques ont été apportés au réacteur depuis le démarrage parmi lesquels 470 t de déchets végétaux, 370 t de déchets de coquillages marins et 80 de déchets de calamars. Le taux d'apport journalier s'établit à 7 t/jour. Au cours de cette étude, la température du réacteur augmente jusqu'à 70°C. L'humidité à l'intérieur du réacteur s'établit à 55% et le pH est supérieur à 8. Le taux de cendres du contenu du réacteur augmente au cours du temps. Cependant, le volume total contenu n'augmente pas, car au cours du procédé les déchets organiques sont décomposés et seules les cendres et une part de MO résiduelle demeurent dans le réacteur.

## 1. Introduction

Couillard et al (1989) used the thermophilic aerobic process to treat organic wastewater that initially had a high COD. In their study, they maintained their reactor in the thermophilic range by using heaters. Paulsrud and Langel (1985) studied aerobic thermophilic digestion of pre-thickened sludge. They studied the decomposition of the pre-thickened sludge according to the principals of composting, without any additives to act as a bulking agent or water absorbent. Liu et al. (1992, 1993) investigated the treatment of organic wastewater that initially had a high BOD and high-suspended solids. Their process reactor contained cedar chips as bulking agents and a water absorbent and air was supplied through the bottom of their reactor, so the organic matter was decomposed aerobically within the thermophilic range. This thermophilic aerobic process basically operates according to the same principles as composting, but the high temperatures and long retention time result in a low volume of ash instead of a large quantity of finished compost product. In Liu's reactor, wastewater was evaporated by the heat generated in the reactor and the organic matter was decomposed almost completely.

Composting of livestock wastes and kitchen wastes is becoming popular in Japan. However, it is becoming harder to distribute the compost product to farmers, because many poultry and swine farmers and municipalities are producing compost from animal wastes, kitchen wastes and sludge. Essentially, more compost is being produced than distributors can sell. It is also becoming harder to incinerate or landfill the organic wastes from food industries and households because those treatments are not economical and legislation is strict. As a result, food industries, distributors and suppliers of agricultural products have been eager to reduce the volume of their wastes as much as possible.

The thermophilic aerobic process was developed to decompose organic wastes into carbon dioxide, water and a small volume of ash. The first full-scale plant was

constructed in Hokkaido in 1997. There are many agricultural product distributors and seafood industries in Hokkaido. The treatment facility was built for decomposing industrial food wastes, including waste vegetables, scallop and squid wastes, etc. This study was carried out to determine the decomposition rate of organic wastes using the thermophilic aerobic process at this full-scale plant.

## 2. Materials and methods

### Full scale plant

The treatment facility consists of a reactor, a feeding cart, four augers and a bio-filter as shown in figure 1. The process reactor is 52 m long, 6 m wide and 2.5 m deep, with a total volume of 630 m<sup>3</sup>. The reactor contains cedar chips ranging in size from 5 mm to 30 mm, to a depth of 1.65 m, for a total volume of cedar chips of 415 m<sup>3</sup>. Air is supplied continuously through the bottom of the reactor at a rate of 45 m<sup>3</sup>/min by a blower. The wastes are added once per day by a feeding cart that travels over the reactor. Four vertical augers agitate the reactor contents, including the combination of cedar chips and decomposed waste, every four hours. The official decomposing capacity of the reactor is 20 t/day. A bio-filter (15 m long, 5.4 m wide and 2.5 m deep) is used to deodorize the exhaust gas. The filter contains the same cedar chips as the reactor. The chips were smeared with activated sludge. Exhaust air is blown out at an air rate of 160 m<sup>3</sup>/min.

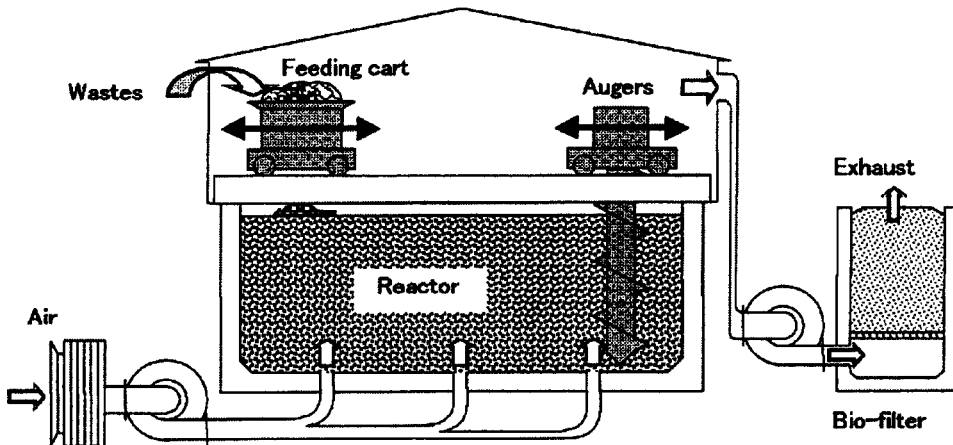

Figure 1  
Schématic of full scale reactor

## Sampling and analyses

Samples were taken manually from 9 fixed locations within the reactor every Thursday. The sampling locations were about 50 cm beneath the surface of the reactor contents. We determined that the composition of the reactor contents at the surface and the bottom of the reactor was similar, because the reactor contents were well agitated by the augers. All samples were analyzed for bulk density, moisture content, pH and ash content. The first and last samples were analyzed for N, P, K, C and cadmium contents.

## 3. Results and discussion

### Wastes materials

The facility was originally put into operation on May 10, 1997. We studied this facility for approximately 2 months, from August 29 to October 25, 1997. Prior to our study, a record of the feeding rate and the temperature of the reactor contents was maintained.

A total of 924 t of organic wastes were added to the reactor at an average rate of about 7 t/day over the 160-day period from May 10 to October 25, with the exception of 30 days when the facility was temporarily shut down, as shown in figure 2. This waste consisted of 470 t of vegetables waste, 373 t of scallop waste and 80 t of squid waste as shown table 1. Over the course of this two-month study, a total of 344 t of organic wastes were added to the reactor, including 234 t of vegetable waste and 110 t of scallop waste, at an average feeding rate of 8.6 t/day. The maximum amount that added on any one day was 22 t.

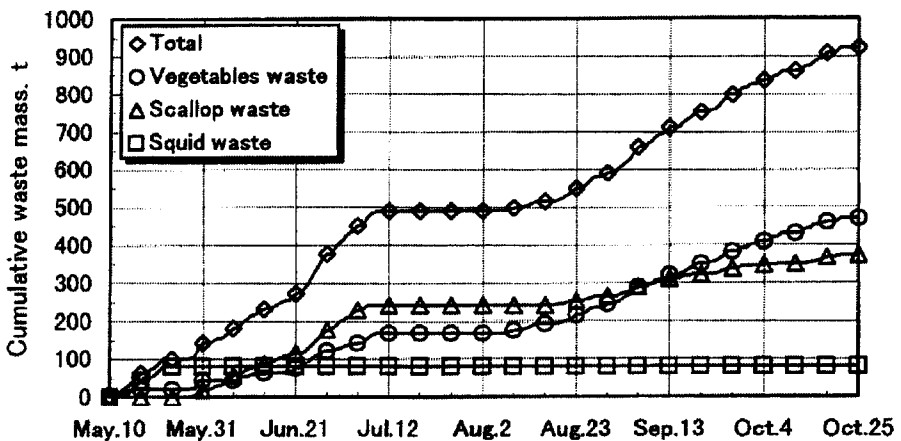

Figure 2  
Cumulative added waste mass.

	Mass (t)	Moisture content (%)	Ash content (% DM)	Cd (mg/kg DM)
Vegetable waste	470.5	90.1	6.5	-
Raw scallop waste	186.5	86.0	18.9	60.0
Boiled scallop waste	186.5	76.4	6.7	21.2
Squid waste	80.0	64.8	4.7	79.5
Mixture	923.5	84.3	8.4	32.7

*Table 1*  
*Added waste (May 10~Oct.23)*

The initial moisture content of the incoming waste mixture was approximately 85%. The initial ash content of the vegetable waste was about 6%, that of raw scallop waste was about 19 % and that of squid wastes was 5% as shown in table 1.

### **Temperature**

The reactor temperature was measured at 3 places, each about 50 cm below the surface of the reactor contents. The average temperature of the reactor reached a maximum of 73°C and was generally maintained between 45° and 70°C as shown in figure 3.

When the reactor was first put into operation in May, aerobic digestion became active shortly after the first waste was added and the reactor temperature increased. The temperature reached around 70°C at the beginning of July, about three months after the reactor started. When no new waste was added during the period from July 11 to August 7, the temperature decreased gradually and was about 25°C at the beginning of August. Once feeding resumed on August 8, the temperature rose quickly to 70°C and was maintained between 45°C and 70°C, just like the initial period of operation before feeding was temporarily suspended. Because new waste was not added on Sundays, the temperature on Mondays tended to be slightly lower than on other days. However, the temperature rose again on the following day, after fresh waste was added.

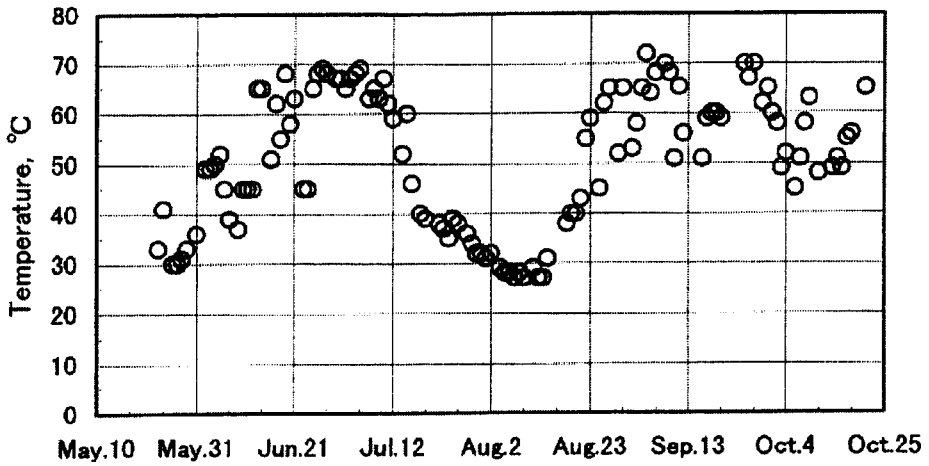

Figure 3  
Temperature of reactor

### Moisture content

The moisture content of the reactor contents, including the combination of cedar chips and decomposed waste, was maintained between 53% and 57% during this study. The moisture content at the auger side of the reactor tended to be higher than the moisture content at the feeder side, as shown in figure 4. This may be due to the fact that when the fresh waste, which has a high moisture content, was dumped from the feeding cart, it tended to fall more towards the auger side than the feeder side. Also, the exhaust air is blown from the feeder side to the auger side, which could tend to dry the reactor contents at the feeder side.

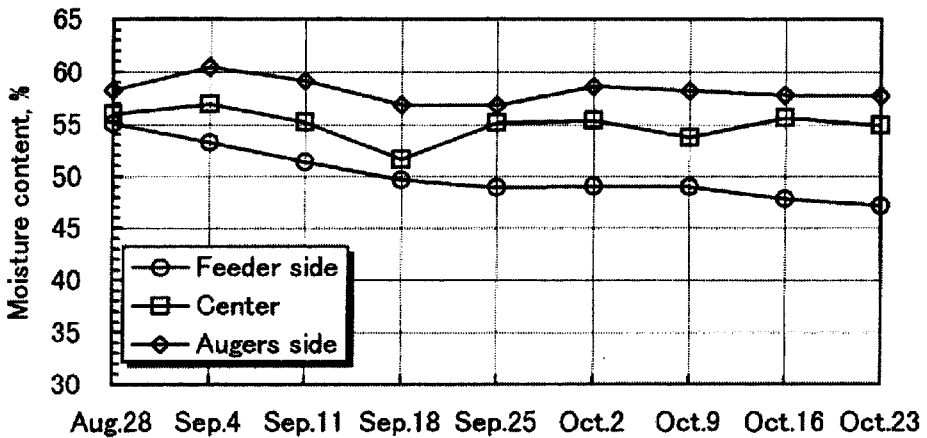

Figure 4  
Moisture content of reactor

## pH

The average pH values of the reactor contents were maintained between 7.8 and 8.3 during this study. These alkaline pH values meant that added organic wastes were well digested aerobically. The pH values recorded at the auger side and the central part were more than 8, but the pH values at the feeder side were about 7, as shown in figure 5. Because less fresh waste was added to the feeder side, and because the moisture content at the feeder side was less than 50%, it was thought that the aerobic digestion process might actually be more active near the augers and central part, resulting in elevated ammonium nitrogen concentrations at these locations.

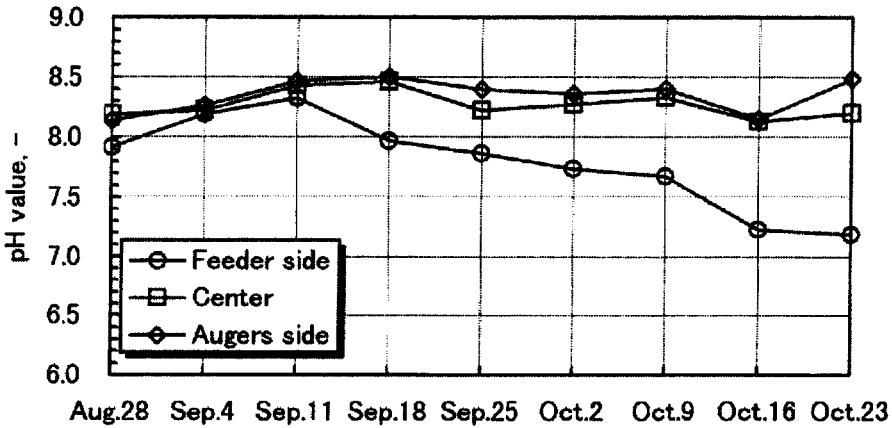

Figure 5  
pH of reactor

## Ash

Figure 6 shows the measured and estimated ash content of the reactor contents. The measured ash content is calculated from the ash content of samples taken from the reactor, as well as the volume and mass of the reactor contents. The estimated ash content is calculated based upon the average ash content of the added wastes, and the volume and mass of the reactor contents. The ash content increased over time, as fresh wastes were added and the wastes were converted into water, carbon dioxide and ash.



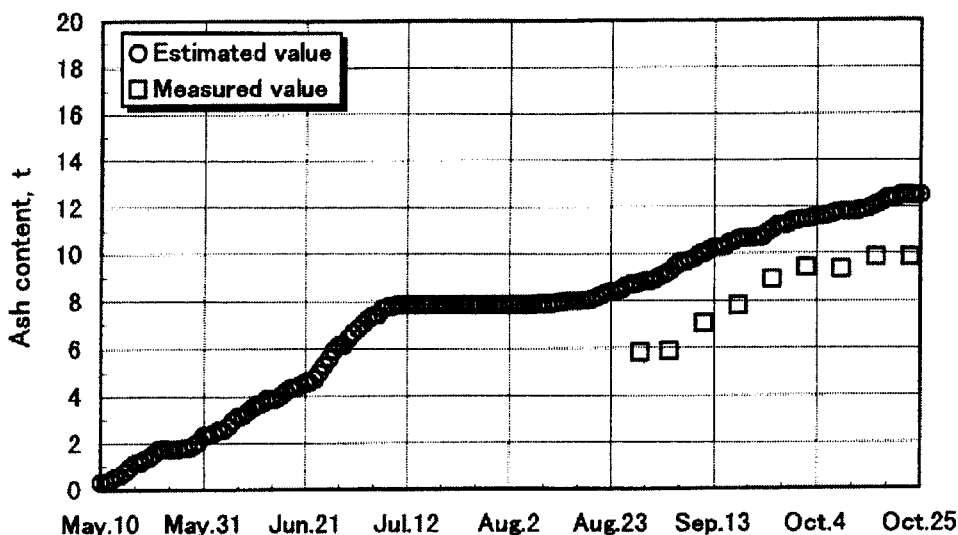

Figure 6  
Ash content of reactor

The relationship between the measured ash content (y) and the estimated ash content (x) is linear and can be expressed as  $y = 1.23x - 5.21$ . The coefficient of determination of the regression equation between them is more than 0.96. The reason why the relationship is not precisely  $y = x$  is that the ash content of the added wastes and the mass of the reactor contents could not be measured precisely.

Over the two-month course of this study, a total of 344 t of organic wastes were added to the reactor. However, the total volume of the reactor contents did not increase at all over time, because only the residual ash and a small amount of organic wastes remained in the reactor along with the cedar chips, which are slow to decompose. Figure 7 shows the masses of organic matter and ash on August 28, the masses of ash and organic matter added during this study, and the masses of organic matter and ash on October 23. As shown in the figure, at the beginning of the study the reactor contained a total of 63.9 (= 58.1+ 5.8) t of organic matter plus ash. During the study, the total organic matter and ash added to the reactor amounted to 43.7 (=3.8+39.9) t. By the time the study finished on October 23, the reactor contents had increased by only 9.4 (=4.0+5.4) t, even though the reactor received 344 t of fresh organic waste over the two month period. The decomposition rate of the added organic matter can be calculated as  $(39.9-5.4) / 100 / 39.9 = 86.5 \%$ . The reduction rate of the added wastes including water can be calculated as  $(299.8+39.9+3.8-4.0-5.4) / 100 / (299.8+39.9+3.8) = 97.2 \%$ , where 299.8 t is the water content of added wastes.

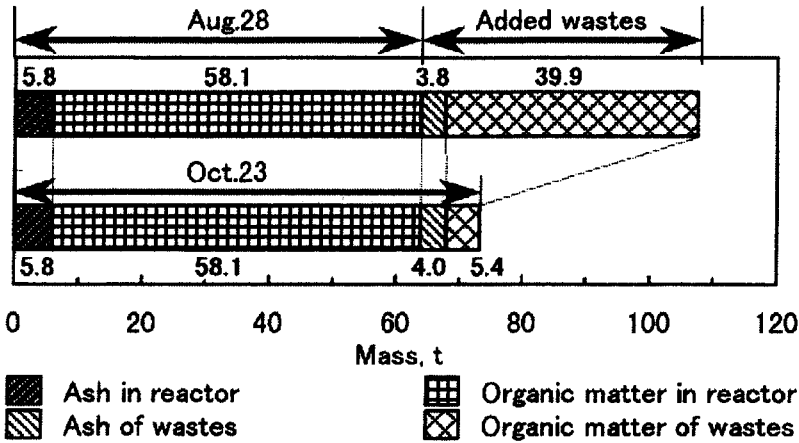

Figure 7  
Components of reactor contents

In conclusion, the added organic matter decomposed at a rate of 86.5% and the reduction rate of the added wastes was 97.2 %. Because a large portion of the waste was decomposed or reduced using the thermophilic aerobic process, the total volume of the reactor contents did not increase at all over time. The facility can be expected to operate for a long period of time, perhaps even two or three years, without removing the finished product (ash) from the reactor.

	MC %	pH	Ash %DM	T-C %DM	T-N %DM	C/N	P2O5 %DM	K2O %DM	Cd mg/kgDM
Aug.28	56.4	8.1	9.1	42.8	1.86	23.1	1.38	1.40	48.6
Oct.23	53.3	8.0	13.4	41.3	2.48	16.7	1.68	2.31	57.1

Table 2  
Average results of reactor contents

Table 2 shows the average results of the reactor contents. When organic wastes are added to a typical composting process, the nitrogen, phosphorus, potassium and carbon contents can be expected to increase. In the thermophilic aerobic process, however, the carbon is converted to carbon dioxide and the nitrogen is emitted as ammonia, so the carbon and nitrogen contents were not expected to increase much during decomposition. In fact, the carbon decreased but the nitrogen did not decrease in this study, so the C/N ratio decreased. Phosphorus, potassium and cadmium accumulated during this study. Since the final products from this facility include cadmium, the products cannot be used as fertilizer and must be properly disposed of at an enclosed landfill site.

## Conclusions

Industrial food wastes were decomposed using the thermophilic aerobic process in a full-scale plant, consisting of a reactor containing cedar chips as a bulking agent and water absorbent. The reactor volume was 780 m<sup>3</sup> and a total of 344 t of industrial food wastes were added over the two-month period of this study. The temperature of the reactor contents was maintained between 45 C and 70 C and the pH of the reactor contents ranged between 7.8 and 8.3. As the wastes were added every day, the ash content of the reactor increased. However, the total volume of the reactor contents did not increase at all over time, because only the residual ash and a small amount of organic wastes remained in the reactor. The added organic matter decomposed by 86.5 % over the course of this study, and the waste was reduced by 97.2 %.

## References

**Couillard, D., Gariepy, S. and Tran, F.T.** (1989) Slaughterhouse effluent treatment by thermophilic aerobic process. *Water research*, 23(5) pp.573-579

**Paulsrud, B. and Langeland, G.,** (1985) Aerobic thermophilic digestion of pre-thickened sludge using air. In: Bruce, A.M., L'Hermite, P. and Newman, P.J. (eds) *New developments in processing of sludge and slurries*. Elsevier applied science publishers. London, UK, pp.49-58

**Liu, B., Noda, S. and Mori, T.** (1992) Complete decomposition of organic matter in high BOD waste water by thermophilic oxic process. *Proceedings of environmental engineering research*, 29, pp.77-84

**Liu, B. and Mori, T.** (1993) Complete treatment of shochu processed wastewater by thermophilic oxic process. *Proceedings of environmental engineering research*, 30, pp.165-174.

## Ammonia removal from swine wastewater using immobilized nitrifiers

*Elimination en azote ammoniacal dans les lisiers de porcs en utilisant une technique d'immobilisation des nitrifiants.*

**Matias B. Vanotti and Patrick G. Hunt**

Agricultural Research Service. U.S. Department of Agriculture  
USDA-ARS-Coastal Plains, Soil, Water and Plant Research Center  
2611 W-Lucas St, Florence, SC 29501, USA.  
e-mail : vanotti@sunbrn.florence.ars.usda.gov

### Abstract

*Environmental pollution from animal waste is a major concern in the U.S.A. due to the rapid growth of confined animal production. This concern includes ammonia emissions, contaminated ground and surface water, and unexpected ecological shifts. Liquid swine manure is mostly treated and stored in large (0.25- to 5-ha) anaerobic lagoons before land application. For storage periods of 180 days typical of the Southeast, more than 50% of the nitrogen (N) entering the lagoon is lost by ammonia volatilization. Its subsequent deposition across the landscape may be the largest form of nitrogen non-point source pollution in the region. A possible solution is to remove ammonia through the transformation into  $N_2$  using nitrification-denitrification systems. In order to overcome low nitrification rates in swine wastewater, we evaluated a new technology that uses immobilized nitrifying bacteria. The technology has been successfully applied to municipal wastewater treatment providing higher nitrification rates, shorter hydraulic residence times (HRT), and smaller reactors. Shorter HRT is critical for development of nitrification units to treat animal waste because aeration cost can be a limiting factor. Acclimated nitrifying cells were immobilized in 3- to 5-mm polyvinyl alcohol polymer pellets. Swine wastewater was treated in aerated, fluidized bioreactors with a 15% (w/v) pellet concentration using batch and continuous flow treatment. In batch treatment, 14 h were needed for total nitrification of ammonia-N (~250 mg N/L). In contrast, it took 10 d for a control (no-pellets) aerated reactor to start nitrification, and 69% of ammonia-N was lost by air stripping. In continuous flow treatment, ammonia removal efficiencies of more than 90% were obtained with ammonia loading rates of 418 mg N/L/d and HRT of 12 h. The rate of nitrification of swine wastewater obtained with HRT of 4 h was 604 mg N/L/d. The high nitrification rates obtained in this work indicate that the immobilized nitrifiers technology has potential application for reducing ammonia loss from confined animal production.*

**Keywords** : ammonia removal, swine wastewater, nitrification treatment, immobilized nitrifiers.

## Résumé

La pollution de l'environnement par les déjections animales est une préoccupation importante aux USA notamment à cause du développement de la production. Ces préoccupations concernent les émissions d'ammoniac, la contamination des eaux souterraines et de surface. Le lisier de porc est principalement stocké et traité dans de vastes lagunes anaérobies (0.25 à 5 ha de superficie) avant épandage sur les champs. Au cours de périodes de stockage de l'ordre de 180 jours, rencontrées dans le sud-est des Etats-Unis, plus de 50% de l'azote (N) entrant dans la lagune est perdu par volatilisation ammoniacale. Le dépôt ultérieur de cet azote à travers le paysage est peut être la principale forme de pollution azotée diffuse. Une solution possible consiste à éliminer l'azote ammoniacal à travers une transformation en azote moléculaire (N<sub>2</sub>), en utilisant la nitrification-dénitrification. Afin de surmonter les faibles taux de nitrification obtenus habituellement dans les lisiers de porcs, une nouvelle technologie a été évaluée qui utilise les bactéries nitrifiantes immobilisées. Les cellules nitrifiantes ont été immobilisées dans des granulés (polymères). Le lisier de porc recevant 15% (poids / volume) de granulés a été traité par aération. Dans les séquences en discontinu 14 h ont été nécessaires pour obtenir une nitrification complète de l'azote ammoniacal (≈ 250 mg N/L). Le temps nécessaire pour obtenir un début de nitrification dans le lisier témoin (sans granulés) était de 10 jours. En système en continu, le taux d'élimination d'azote ammoniacal s'établit à plus de 90% avec des charges de l'ordre de 418 mg N/L/j et un temps de rétention hydraulique de 12 h.

Ces taux de nitrification élevés témoignent que la technologie d'immobilisation des nitrifiants présente un potentiel d'application afin de réduire la pollution et les pertes ammoniacales.

**Mots-clés** : élimination N-ammoniacal, lisier porc, traitement par nitrification, nitrifiants immobilisés.

## 1. Introduction

During recent decades, animal production methods in the U.S.A. have undergone dramatic changes. The predominant trend has seen animal production changing from small, individual operations into large, confined, commercial enterprises. For example, the number of hog farms in the U.S.A. has dropped from 600,000 to 157,000 over the past 15 years. Yet, the country's inventory of pigs has remained almost the same (USDA, 1995). Most noticeable is the case of the swine industry in the state of North Carolina, where hog populations have increased from 3 million to more than 9 million in the last five years and where 97% of the production activity is concentrated in large operations. On the average, each of these operations has 5100 hogs and produces 45.2 Mg of collectable manure-N per year (Barker and Zublena, 1995; USDA, 1995). Typical facilities use flush or pit-recharge systems to

remove manure from the confinement houses. The flushed waste is mostly treated and stored in large anaerobic lagoons (0.25 to 5 hectares) and later applied to cropland.

Anaerobic lagoons are designed to perform a significant reduction in the organic content of the flushed waste. Although the anaerobic digestion process can reduce 80% or more of the organic matter from these high-strength wastewaters, these open lagoon systems are not without significant adverse environmental impact. Specifically, organic N is converted to free ammonia ( $\text{NH}_3$ ) with much of it volatilized from the lagoon's surface. It may be anticipated that in a lagoon of long-term retention, 50 to 80% of the N will escape to the atmosphere (Miner and Hazen, 1977; Muck and Steenhuis, 1982; Barrington and Moreno, 1995; Braum et al., 1997). Recent estimates of  $\text{NH}_3$  emissions from swine lagoons in North Carolina indicate that about 30 Mg of  $\text{NH}_3$  per day volatilizes from a total of 2,000 ha of lagoons (Crouse et al., 1997). Once in the air, the ammonia may diffuse down into the surrounding land, or be carried away by wind and diffuse down into soil and water several miles from the source. Hutchinson et al. (1972) showed that plants can also serve as sinks of significant quantities of  $\text{NH}_3$  from the air even at low atmospheric concentrations. It is estimated that airborne pollution now accounts for about one-third of the 2,300 Mg of N that enter the Neuse River basin of the eastern U.S.A. each year (Hans Paerl, pers. comm.). These and other considerations, such as the potential for contaminated ground and surface waters, fish kills, and unexpected ecological shifts, provide ample reason for a greatly increased interest in controlling ammonia emissions from confined animal production.

## **2. Ammonia Removal Through Biological Nitrification-Denitrification Treatment**

An efficient method to remove ammonia from animal lagoon wastewater is through on-farm biological nitrification-denitrification control processes. The effectiveness of such biological nitrogen removal processes depends on the ability of nitrifying organisms to oxidize  $\text{NH}_3$  to nitrate ( $\text{NO}_3\text{-N}$ ). Once in a nitrate form, the transformation into  $\text{N}_2$  (or denitrification process) needs two conditions: a source of carbon and an anaerobic environment. These conditions are typically found in wetlands or liquid manure storage units. Using lagoon swine wastewater with a nitrification pretreatment, Rice and coworkers (1998) increased more than five times the N removal potential of constructed wetlands. Bernet and coworkers (1996) found that denitrification can also be carried out in the same tank used for anaerobic digestion of swine wastewater. Their results indicate that design of a practical process combining anaerobic digestion and denitrification coupled to a nitrifying reactor needs consideration of the carbon (C) to  $\text{NO}_3\text{-N}$  ratio in order to obtain complete nitrate reduction to molecular N.

The basic problem related to nitrification in wastewaters with a high content of organic carbon is the low growth rate of the nitrifying bacteria; the generation time of these microorganisms is about 15 hours. Compared to heterotrophic microorganisms, which have generation times of 20-40 minutes, the nitrifiers compete poorly for limited oxygen and nutrients and tend to be overgrown or washed out (Figueroa and Silverstein, 1992; Wiffels et al., 1993).

The nitrification of lagoon swine wastewater is an especially difficult process because of the very low numbers of nitrosomonas and nitrobacter usually found after anaerobic treatment (Blouin et al., 1989). Even when the oxygen supply is plentiful, an adaptation period is needed to reach a minimum bacteria concentration before effective nitrification. In the absence of enriched nitrifying populations, aerobic treatment of lagoons can potentially add to problems by stripping ammonia into the atmosphere, particularly if uncontrolled or excessive flow rates of air are used (Burton, 1992). To overcome these problems, we recently proposed the use of immobilized nitrifying cells in polymer pellets for enhanced nitrification of swine wastewater (Vanotti and Hunt, 1996). This is an attractive approach to biological ammonia removal as applied to animal systems because the capacity of the reactor can be increased by increasing the nitrifiers' retention time independent from the wastewater retention time.

### **3. Immobilization Technology**

Advances in biotechnology using immobilization technology have shown that conditions can be modified to enhance the activity of specific microorganisms performing a desirable chemical process. The immobilization of microorganisms in polymer resins is a widely applied technique in drug manufacturing and food processing. The application for municipal wastewater treatment has been recently developed and tested in Japan (Tanaka et al., 1991; Takeshima et al., 1993), and there are currently several full-scale municipal wastewater treatment plants using this technology. This was the result of a 10-year comprehensive research project intended to solve wastewater treatment problems using biotechnology. Through the immobilization process, the nitrifying microorganisms are provided with a very suitable environment to perform at maximum effectiveness. The nitrifiers are entrapped in 3- to 5-mm pellets made of polymers that are permeable to  $\text{NH}_3$ , oxygen and carbon dioxide needed by these microorganisms, resulting in a fast and efficient removal of  $\text{NH}_3$ . Typical materials are polyethylene glycol (PEG) and polyvinyl alcohol (PVA); these pellets are functional for more than 10 years. Wastewater is treated in a nitrification tank equipped with a wedge-wire screen to retain the pellets and a whole-floor aeration system to ensure high oxygen transfer and appropriate fluidization. Pellet volume is usually 7 to 15% of the total reactor volume. Nitrification rate with this technology can be three times higher than those of the conventional activated sludge process (Tanaka et al., 1991). This is

important when assessing the application of nitrification technologies for animal systems because construction and aeration cost can be limiting factors.

#### **4. Immobilization of Acclimated Swine Wastewater Nitrifying Bacteria**

*Preparation of nitrifying culture.* An active culture of acclimated swine wastewater nitrifying bacteria (ANB) was prepared from seed sludge obtained from an overland flow treatment field used for nitrification of anaerobic lagoon wastewater effluent. The seed sludge was diluted to a level of 0.62 g/L by an inorganic salts medium (Furukawa et al., 1993) using a fill-and-draw cultivation method. The  $\text{NH}_4\text{-N}$  concentration of the medium was fixed to 300 mg/L, and the pH was adjusted to 8.5 by addition of 1 N  $\text{K}_2\text{CO}_3$  twice a day. The cells were harvested after 10 days of incubation at 35°C. The cultivation procedure yielded 1 g-MLSS/L with a nitrification activity of 7.06 mg  $\text{NH}_4\text{-N/g-MLSS/h}$ .

*Immobilization technique.* The ANB was concentrated by sedimentation to 58 g/L and immobilized by a PVA-freezing method. One unit of concentrated ANB was mixed on a weight basis with one unit of 20% (w/v) PVA-HC (100 % saponification, Kurare Co., Osaka)<sup>1</sup> warm aqueous solution at 45°C. The mixture was then poured into a plastic tray, and frozen for 16 h at -4°C. After fast thawing, immobilized ANB-pelletized cubes of 3-5 mm were prepared using a sharp blade. The immobilized pellets were washed with the inorganic medium under aeration until foaming by unpolymerized PVA stopped. Pellets were produced at a rate of 766-g (wet) or 875-ml pellets per 1000 g of ANB-PVA initial mixture and contained 37.9 mg ANB/g-pellet (wet).

*Recovery culture.* Recovery cultures of immobilized ANB were carried out by the fill-and-draw cultivation method during 2 d at 35°C using inorganic salts medium under a loading rate of 2.0-mg  $\text{NH}_4\text{-N/g-pellet/d}$ . Recovered immobilized ANB pellets with a nitrifying activity of 2.06-mg  $\text{NH}_4\text{-N/g-pellet/d}$  were used in subsequent batch and continuous experiments. The nitrifying activity of ANB after immobilization and recovery was 2.27-mg  $\text{NH}_4\text{-N/g-MLSS/h}$ , which is 32.1% of the activity before immobilization. This activity is similar to values of 1.74- to 2.11-mg  $\text{NH}_4\text{-N/g-MLSS/h}$  reported by Furukawa et al. (1993) using acclimated marine nitrifiers.

---

<sup>1</sup>Mention of trademark, proprietary product, or vendor does not constitute a guarantee or warranty of the product by the U.S. Dept. of Agriculture and does not imply its approval to the exclusion of other products or vendors that also may be suitable.



## 5. Nitrification of Swine Wastewater Using Batch Treatment

Batch experiments were conducted to elucidate conditions that optimize nitrification of lagoon wastewater. The reactors consisted of conic aeration tanks with air supplied from the bottom of the tanks to ensure full fluidization of nitrifying pellets. Average dissolved oxygen concentration was 7.7-mg O<sub>2</sub>/L. Pellets were added at 15.3% (w/v) [17.5% (v/v)] pellet to total volume ratio. Temperature was controlled using a circulated water bath and heat regulator. All experiments were conducted at 30°C. The wastewater used was a lagoon effluent from a swine operation in Duplin County, North Carolina. It contained 233-mg NH<sub>4</sub>-N/L, 250-mg TKN/L, and 0 nitrate and nitrite. Other characteristics were 200-mg TSS/L, 150-mg BOD<sub>5</sub>/L, 1357-mg alkalinity/L, and a pH of 8.3.

Data in Fig. 1 identify inhibitory boundary conditions of NH<sub>4</sub><sup>+</sup> and NO<sub>2</sub><sup>-</sup> oxidation of swine wastewater by immobilized nitrifiers. During NH<sub>4</sub><sup>+</sup> oxidation, there is a release of hydrogen ions that decreases the pH to an extent related to the buffering capacity of the system. The alkalinity concentration of the wastewater (1357-mg CaCO<sub>3</sub>/L) was lower than the 1670 mg/L needed for complete oxidation of 233-mg NH<sub>4</sub>-N/L (assuming 7.14-mg CaCO<sub>3</sub>/mg NH<sub>4</sub>-N). As the NO<sub>2</sub>-N accumulated and the pH decreased during progression of nitrification, the free un-ionized nitrous acid (HNO<sub>2</sub>) increased to a value ( 0.2 mg/L) that inhibited NH<sub>4</sub><sup>+</sup> oxidation. Addition of NaOH pulses at 12-15 h relieved this inhibition, and NH<sub>4</sub><sup>+</sup> oxidation was completed. On the other hand, oxidation of NO<sub>2</sub>-N was inhibited during the first 9 h and during the pH adjustment period when un-ionized (free) NH<sub>3</sub> levels were higher than 1 mg/L. These values are consistent with the benchmark nitrification work of Anthonisen et al. (1976). Their studies showed boundary concentrations of 0.2 to 2.8 mg/L for free nitrous acid inhibiting NH<sub>4</sub><sup>+</sup> oxidation, and 0.1 to 1.0 mg/L for free ammonia affecting the oxidation of NO<sub>2</sub>-N.

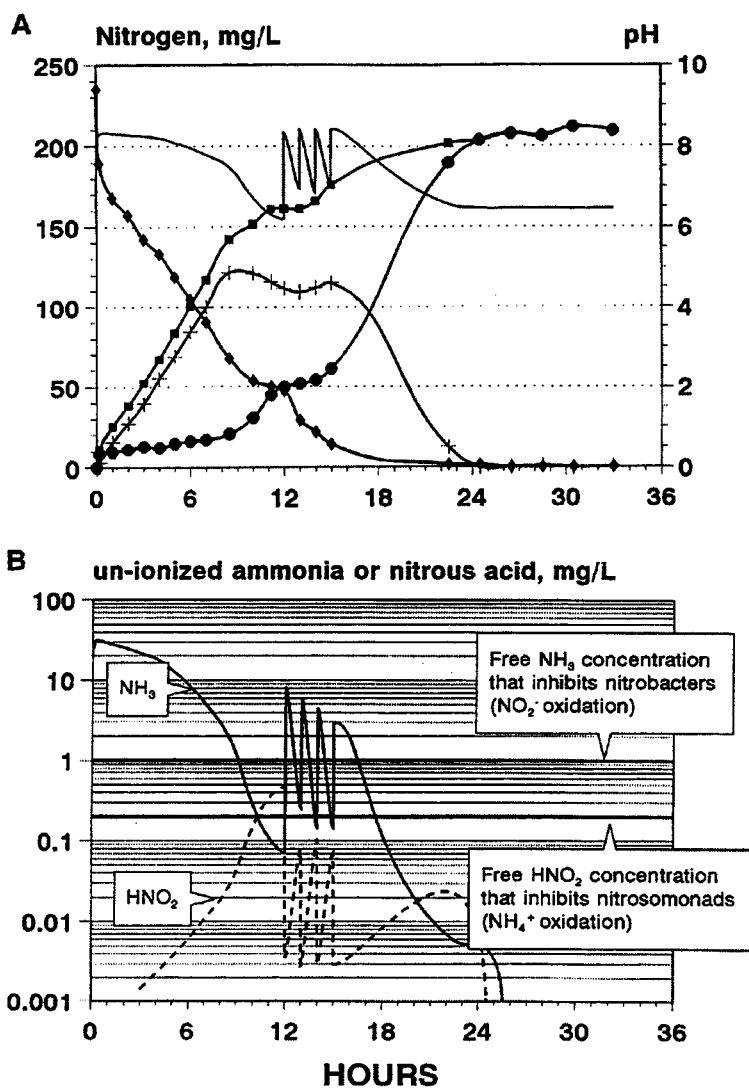

Figure 1

Nitrification of lagoon wastewater with immobilized nitrifiers, batch treatment.

**A:** Nitrogen transformations during inhibited nitrification; ( $\blacklozenge$ )  $\text{NH}_4^+$ , ( $+$ )  $\text{NO}_2^-$ , ( $\bullet$ )  $\text{NO}_3^-$ , ( $*$ )  $\text{NO}_2^-$  plus  $\text{NO}_3^-$ , and ( $-$ ) pH.

**B:** Inhibitory boundary conditions of  $\text{NH}_4^+$  and  $\text{NO}_2^-$  oxidation.

Inhibition of  $\text{NH}_4^+$  oxidation by free nitrous acid can be easily relieved with pH control. Such a system is shown in Fig. 2; swine wastewater was supplemented with a pH 8.5  $\text{CO}_3^{2-}/\text{HCO}_3^-$  buffer in order to add an extra 600 mg/L of alkalinity and meet  $\text{H}^+$  demands of  $\text{NH}_4^+$  oxidation. Under these conditions,  $\text{NH}_4^+$  was completely

oxidized in 14 h. But oxidation of  $\text{NO}_2\text{-N}$  was still inhibited by high initial free  $\text{NH}_3$  in the lagoon wastewater; therefore, a total of 24 h was needed for complete nitrification to  $\text{NO}_3\text{-N}$ . This limitation is, however, an opportunity for bioengineering research through development of *Nitrobacter* strains adapted to higher levels of free  $\text{NH}_3$ , such as those acclimated to nitrify under harsh saline environments with free  $\text{NH}_3$  concentration of 10 to 20 ppm (Furukawa et al., 1993).

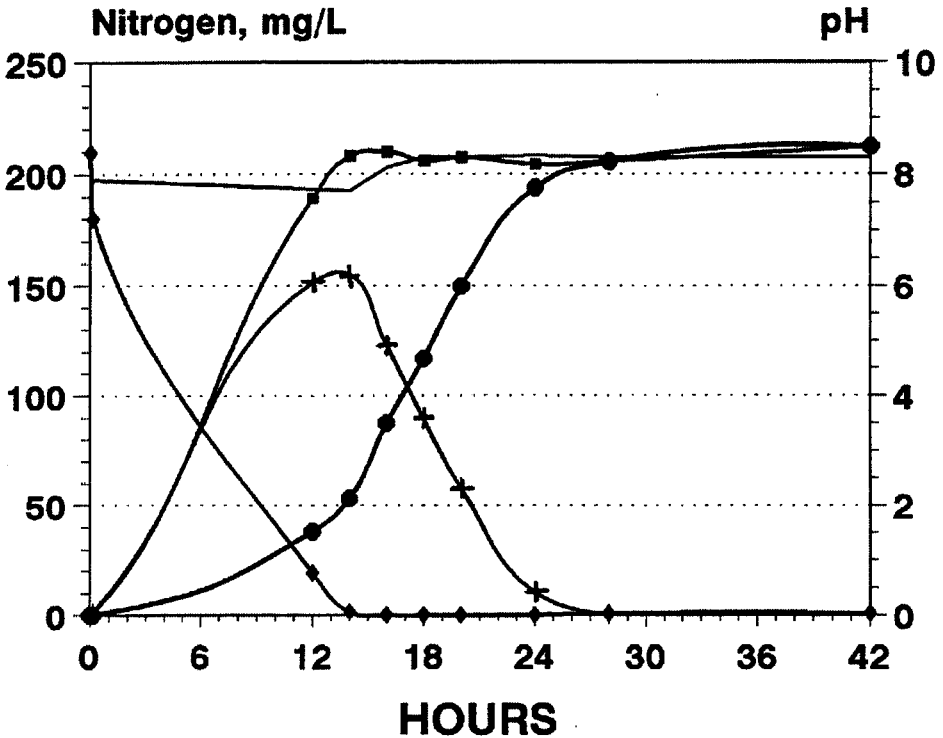

Figure 2  
 Nitrification of lagoon wastewater with immobilized nitrifiers in batch treatment using a  $\text{CO}_3^{2-}/\text{HCO}_3^-$  buffer for optimum process;  
 (◆)  $\text{NH}_4^+$ , (+)  $\text{NO}_2^-$ , (●)  $\text{NO}_3^-$ , (■)  $\text{NO}_2^-$  plus  $\text{NO}_3^-$ , and (-) pH.

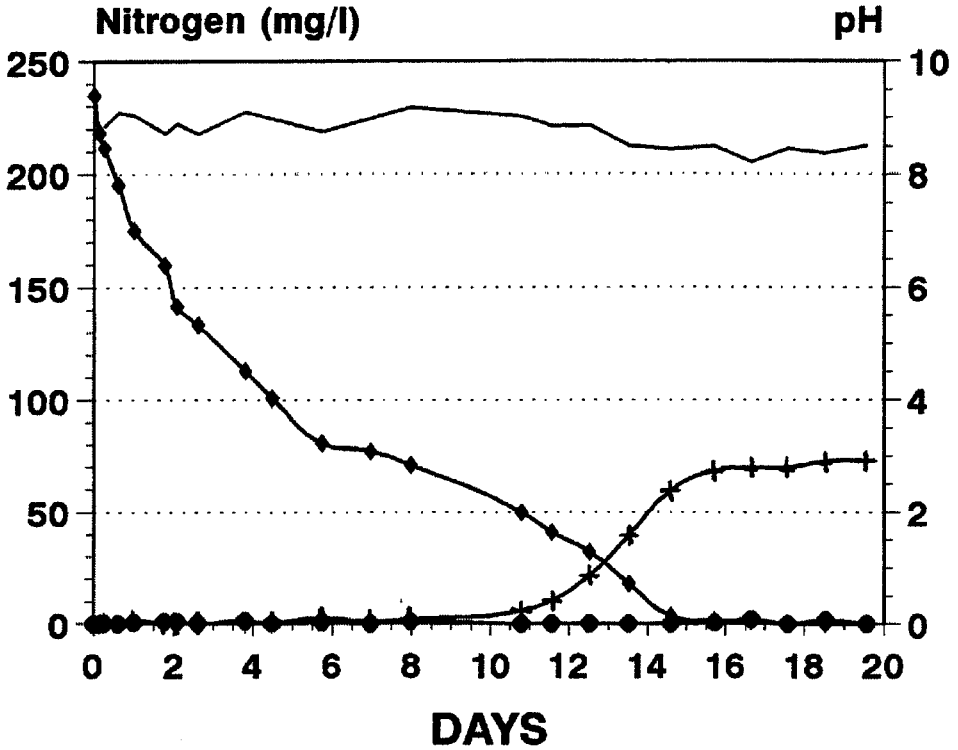

Figure 3  
 Nitrification of lagoon wastewater in a control batch treatment receiving only aeration, without immobilized nitrifiers or pH correction; (◆) NH<sub>4</sub><sup>+</sup>, (+) NO<sub>2</sub><sup>-</sup>, (●) NO<sub>3</sub><sup>-</sup>, and (-) pH.

In the absence of enriched nitrifying populations, aerobic treatment of lagoons can potentially add to problems by stripping out ammonia. This problem is illustrated in Fig. 3, showing the nitrogen transformations in a control treatment that was conducted parallel to the experiment shown in Fig. 1. Nitrification of lagoon wastewater started at 10 d and 69% of NH<sub>4</sub>-N was lost by ammonia volatilization. These results are not surprising because of the low number of nitrifying microorganisms usually found after anaerobic stabilization (Blouin et al., 1989).

## 6. Nitrification of Swine Wastewater Using Continuous Flow Treatment

Ammonia removal potential of ANB pellets was also evaluated under continuous flow treatment. Ammonia loading rates were gradually increased from 227 to a maximum of 1287-g  $\text{NH}_4\text{-N}/\text{m}^3$  of aeration tank per day (corresponding from 1.48- to 8.40-mg  $\text{NH}_4\text{-N}/\text{g-pellet/d}$ , respectively). Loading rates were changed by decreasing the hydraulic residence time (HRT) from 24 h to 4 h. Alkalinity requirements were corrected by adding an extra 600-mg alkalinity/L to the influent swine wastewater using a pH 8.5  $\text{CO}_3^{2-}/\text{HCO}_3^-$  buffer. Pellets were retained inside the reactor with a 1-mm wedge-wire screen placed at the outflow. Other experimental conditions were similar to those described for the batch experiments.

HRT†	Ammonia Loading Rate	Ammonia Removal Rate‡	Nitrate + Nitrite Production Rate§	Nitrification Efficiency¶
hours	g $\text{N}/\text{m}^3$ reactor volume/day			%
24	227	223	240	100
20	260	254	279	100
16	326	311	327	100
12	418	363	397	95
8	637	402	417	65
6	884	498	499	56
4	1287	604	567	44

† Hydraulic residence time

‡ Ammonia removal rate = flow\*( $\text{NH}_4\text{-N}$  conc. inflow -  $\text{NH}_4\text{-N}$  conc. outflow)

§  $\text{NO}_x\text{-N}$  production rate = flow\*( $\text{NO}_3\text{-N}$ +  $\text{NO}_2\text{-N}$  conc. outflow); inflow  $\text{NO}_x$  concentration=0

¶ Nitrification efficiency = ( $\text{NO}_x\text{-N}$  conc. outflow/ $\text{NH}_4\text{-N}$  conc. inflow)\*100

*Table 1*  
*Treatment of lagoon swine wastewater with immobilized nitrifiers under continuous flow*

Nitrification efficiencies of more than 90% were obtained with ammonia loading rates lower than 2.73-mg  $\text{N}/\text{g-pellet/d}$  and HRT higher than 12 h. Nitrification efficiencies decreased to 44% at the highest rate of 8.40-mg  $\text{N}/\text{g-pellet/d}$  (HRT = 4 h). All the ammonia-N removed was converted into nitrate and nitrite forms. Nitrate was predominant at HRT higher than 12 h, while equal amounts of nitrate and nitrite were produced at the highest load. Although higher loading rates resulted in lower nitrification treatment efficiencies, the total amount of  $\text{NO}_x\text{-N}$  produced was higher, with the maximum ammonia removal rate obtained with HRT of 4 h. Higher efficiencies may be useful for total systems designed to meet stream discharge requirements. However, if the objective is to remove large amounts of ammonia from the lagoon, then a retrofit nitrification unit operated at shorter retention times would be recommended. This strategy has the advantage of reducing the total cost of aeration per unit of nitrate-N produced.

## 7. References

- Anthonisen, A.C., R.C. Loher, T.B. Prakasam, and E. G. Srinath.** 1976. Inhibition of nitrification by ammonia and nitrous acid. *Journal WPCF* 48:835-852.
- Barker, J.C., and J.P. Zublena.** 1995. Livestock manure nutrient assessment in North Carolina. *In Proc. of the 7th Int. Symp. on Agr. Wastes.* ASAE, Chicago, Illinois.
- Barrington, S.F., and R. Moreno.** 1995. Swine manure nitrogen conservation using Sphagnum moss. *J. Environ. Quality* 24:603-607.
- Bernet, N., N. Delgenes, and R. Moletta.** 1996. Denitrification by anaerobic sludge in piggery wastewater. *Environmental Technology* 17:293-300.
- Blouin, M., J.-G. Bisailon, R. Beaudet, and M. Ishaque.** 1989. Nitrification of swine waste. *Can. J. Microbiol.* 36:273-278.
- Braum, S.M., J.F. Moncrief, and S.C. Gupta.** 1997. Nitrogen losses from a liquid dairy manure management system. *In Agron. Abstracts.* ASA, Madison, WI.
- Burton, C.H.** 1992. A review of the strategies in the aerobic treatment of pig slurry: Purpose, theory and method. *J. Agric. Eng. Res.* 53:249-272.
- Crouse, D.A., S.C. Hodges, W.P. Robarge, R.L. Mikkelsen, and J.L. Havlin.** 1997. Nitrogen budget for a swine production facility in North Carolina. *In Agron. Abstracts.* ASA.
- Figueroa, L.A., and J. Silverstein.** 1992. The effect of particulate organic matter on biofilm nitrification. *Water Environment Research* 64:728-733.
- Furukawa, K., A. Ike, S. Ryu, and M. Fujita.** 1993. Nitrification of  $\text{NH}_4\text{-N}$  polluted sea water by immobilized acclimated marine nitrifying sludge. *J. Fermentation Bioeng.* 76:515-520.
- Hutchinson, G.L., R.J. Millington, and D.B. Peters.** 1972. Atmospheric absorption by plant leaves. *Science* 175:771-772.
- Miner, J.R., and T.E. Hazen.** 1977. Transportation and application of organic wastes to land. p. 379-425. *In* L.F. Elliot and F.J. Stevenson (eds.). *Soils for Management of Organic Wastes and Waste Waters.* ASA-CSSA-SSSA, Madison, WI. Muck and Steenhuis. 1982. *Agricultural Wastes.* 4:41-47.

**Rice, M., A. Szogi, S. Broome, F. Humenik, and P. Hunt.** 1998. Constructed wetland systems for swine wastewater treatment. *In Proc. Animal Production Systems and the Environment.* Iowa State Univ., July 19-22, Des Moines, Iowa.

**Takeshima, T., K. Motegi, H. Emori, H. Nakamura.** 1993. Pegasus: An innovative high-rate BOD and nitrogen removal process for municipal wastewater. p. 173-181. Proceeding 66th Annual Conference, Water Environment Federation. Anaheim, CA.

**Tanaka, K., M. Tada, T. Kimata, S. Harada, Y. Fujii, T. Mizuguchi, N. Mori, and H. Emori.** 1991. Development of new nitrogen removal system using nitrifying bacteria immobilized in synthetic resin pellets. *Water Science and Technology* 23:681-690. USDA. 1995. *Agricultural Statistics.* U.S. Printing Office, Washington, D.C.

**Vanotti, M.B., and P.G. Hunt.** 1996. The use of polymers for nitrogen removal in swine wastewater: PAM and encapsulated nitrifier technologies. p. 116-120. *In Proc. of Solutions: A technical conference on water quality.* NC State Univ., Raleigh, N.C.

**Wijffels, R.H., E.J.T.M. Leenen, and J. Tramper.** 1993. Possibilities of nitrification with immobilized cells in waste-water treatment: Model or practical system? *Wat. Sci. Tech.* 27:233-240.

## **Microbial fertilizers from pig farm wastes**

*Les engrais microbiens issus des effluents d'élevage.*

**Professor Irina A. Arkhipchenko.**

All-Russia Research Institute for Agricultural Microbiology  
Podbelsky Shosse 3, St.Petersburg-Pushkin 8, 189620, RUSSIA  
E-mail : bamil@riam.spb.su

### **Abstract**

*The process for the treatment of the waste waters from the pig farms has been developed. The process envisages obtaining the microbial biomass with an increased content of nitrogen, phosphorus, potassium and purified water. New microbiological methods for intensifying the aerotank operation, express methods for monitoring the activity of the microbial communities and the quality of the purified water are presented. The biomasse serves as a raw matter for producing a novel effective pelleted fertilizer Bamil. A pilot experimental industrial plant for producing experimental lots of 150 tons yearly has been constructed.*

*Bamil is used as a biofertilizer for vegetable, grain and green house crops. Its base comprises a stable association of the microbes promoting the plant growth. The content of Bamil is stable : nitrogen - 5% ; phosphorus - 1.8 %; potassium - 0.5%. It has positive effects of both the mineral fertilizers (known and controlled content and a low dose of application) and those organic (an increased biological activity of the soils and production of bumper crops of ecologically clean quality action during 2-3 years, supression of microflora inducing the plant diseases). Bamil ensures an increased yield of various agricultural crops : potato - by 10-15 t/ha increasing the starch content in the tubers by 4-5%, vitamin « C » - 1.5-2 fold increase ; perennial grasses hay by 4-7 t/ha ; spring wheat in an afteraction by 8-10 t/ha ; lettuce - a 4-fold increase ; tomatoes - a 3-fold increase.*

*Bamil actively degrades the soil oil contaminations and is successfully applied for recultivation of the soils.*

*Being an easily mineralized organic fertilizer Bamil activates the microbiologic process and produces a positive effect on the nutritional conditions of the soil improving its physical and chemical properties, it actively produces influence on an increase in the humus content. Bamil is especially effective on the soils with a low content of humus.*



*It is produced in the form of dried pellets of the active microorganism biomass. A business plan has been worked out for setting up a plant for producing 10 thousand tons of biofertilizers per year. It has been shown that a yearly profit obtained by selling the fertilizers will amount to 1-1.2 mln \$.*

Keywords : microbial fertilizers, pig-farm wastes, aerotank, soil.

## **Résumé**

On a élaboré une technologie de traitement microbiologique des effluents d'élevage porcin. Cette technologie suppose l'obtention de la biomasse microbienne avec une teneur élevée en azote, phosphore, potassium et eau clarifiée. On a présenté de nouveaux procédés d'intensification du fonctionnement des réacteurs d'aération, les méthodes de contrôle de l'activité des groupes microbiens et de la qualité de l'eau clarifiée. La biomasse sert comme matière première à l'obtention d'un nouvel engrais granulé efficace « bamil ». On a construit une installation industrielle pilote pour la production d'engrais « expérimentaux » (150 t/an). « bamil » est utilisé en qualité d'un engrais biologique pour les cultures maraîchères, céréales et en serre. C'est une association des microbes stimulant la germination des plantes qui forme sa base. La composition de « bamil » est stable : azote 5%, phosphore 1.8%, potassium 0.5%. Il a des qualités propres communes aux engrais chimiques (composition stable), aussi bien qu'aux engrais organiques (augmentation de l'activité biologique des sols et de hauts rendements des produits écologiques purs ; effet pendant 2-3 ans, suppression de la microflore provoquant les maladies des plantes). « bamil » assure l'augmentation du rendement de différentes cultures agricoles : de la pomme de terre à 10-15 t/ha, la teneur en amidon dans les tubercules étant augmentée à 4-5%, celle en vitamine « C » à 1.5-2 fois ; du foin des herbes vivaces à 4-7 t/ha ; du blé de printemps, effet postérieur, à 0.8 t/ha ; de la salade à 4 fois ; des tomates à 3 fois.

« bamil » décompose effectivement les contaminations pétrolières des sols et s'applique avec succès pour la recultivation des sols.

« bamil » étant un engrais facilement minéralisable stimule les processus microbiologiques et influence positivement la fertilité des sols, en améliorant les propriétés physiques et chimiques de ces derniers, il influence activement l'augmentation de la teneur en humus. Il est produit en granules sèches de biomasse des microorganismes actifs. On a élaboré un « business-plan » de la construction d'une usine à capacité de 10 000 tonnes d'engrais biologiques.

Mots-clés : fertilisants microbiens, déchets d'élevage porcin, cuve aérée, sol.

## 1. Introduction

For enhancing the soil fertility and obtaining the agricultural products of ecological quality it is necessary to develop the biotechnological methods for processing the animal breeding wastes with the production of effective microbial fertilizers. Such technologies make it possible to solve two important ecological problems. One of them is associated with utilization of organic wastes and the second one with maintaining the soil fertility, improving the quality and the yield of agricultural products.

The microbial fertilizers possess the positive features both of the mineral fertilizers (known chemical composition; low application dose 1-2 t/ha; absence of the weed seeds, simple application procedure) and of the organic ones (increase in the yield of agricultural crops; enhancing the soil fertility; suppression of the microflora which causes the plant diseases; 2-3 year lasting effect), Table 1.

We have developed and patented the process for obtaining pure water and a microbial fertilizer called Bamil [1] from the pig-farm wastes. At the basis of the fertilizer there is an association of active microorganisms (activated sludge) having an increased content of nitrogen and phosphorus. Prevailing in the association there are nocardio- and corynebacteria of the genera *Rhodococcus*, *Arthrobacter*, *Aureobacterium*, *Mycobacterium*, and the gram-negative of the genera *Alcaligenes*, *Pseudomonas* the majority of which promote the plant growth (2). The biofertilizer Bamil is produced from the mixture of the microflora of the activated sludge and the sediment of the secondary settlers (1:1) which is transferred to the centrifuge in which the moisture content of the mass decreases from 97 down to 80%. Then the mixture is transferred to the granulator and after that - to the drier. The end product with the moisture content 10-15% is packed into the bags 20 kg each (Fig.1). Technical specification, a passport and a certificate have been developed for the biofertilizer.

By chemical parameters Bamil differs from other organic fertilizers by a high content percentage of nitrogen (5); phosphorus (1.8), potassium (0.8), calcium (3.4), magnesium (0.5), zinc (0.05), iron (1), manganese (0.8), copper (0.05), sulphur (0.5), the content of heavy metals is considerably lower than the limiting-admissible values.

<b>Mineral Fertilizers</b>	<b>Microbial Fertilizers</b>	<b>Organic Fertilizers</b>
<p><b><u>Positive features</u></b></p> <ul style="list-style-type: none"> <li>• Increase in the yield of crops by 70-80%</li> <li>• Known chemical composition</li> <li>• Low dose of application 1-2 t/ha</li> <li>• Absence of weed seeds</li> <li>• Simple application procedure</li> </ul>	<p><b><u>Combined positive action</u></b></p> <ul style="list-style-type: none"> <li>• Increase in the yield of crops by 70-80%</li> <li>• Remediation of soil, improvement of its fertility</li> <li>• Plant growth stimulator</li> <li>• Suppression of microflora inducing plant diseases</li> <li>• Positive effect during 2-3 years</li> </ul>	<p><b><u>Positive features</u></b></p> <ul style="list-style-type: none"> <li>• Increase in the yield of crops by 70-80%</li> <li>• Remediation of soil, improvement of its fertility</li> <li>• Plant growth stimulator</li> <li>• Suppression of microflora inducing plant diseases</li> <li>• Positive effect during 2-3 years</li> </ul>
<p><b><u>Negative features</u></b></p> <ul style="list-style-type: none"> <li>• Pollution of the environment, ground waters</li> <li>• Increase in the nitrates content in plants</li> <li>• High cost</li> <li>• Lack of positive aftereffect</li> </ul>	<p>.....</p> <ul style="list-style-type: none"> <li>• Increase in the yield of crops by 70-80%</li> <li>• Known chemical composition</li> <li>• Low application dose 1-2 t/ha</li> <li>• Absence of weed seeds</li> <li>• Simple application procedure</li> </ul> <p><b><u>Negative features</u></b></p> <ul style="list-style-type: none"> <li>• Volatile compounds with a strong smell</li> </ul>	<p>←</p> <p><b><u>Negative features</u></b></p> <ul style="list-style-type: none"> <li>• High application dose 60-80 t/ha</li> <li>• 1 t contains up to 12 mln weed seeds</li> <li>• Optimal distance of transportation is 3-4 km</li> <li>• Complicated application procedure</li> <li>• Nitrogen losses are up to 50% during 2 months</li> </ul>

*Table 1.  
Advantages of microbial fertilizers*

Microbial fertilizers from the livestock and poultry wastes possess the positive features both of mineral and organic fertilizers

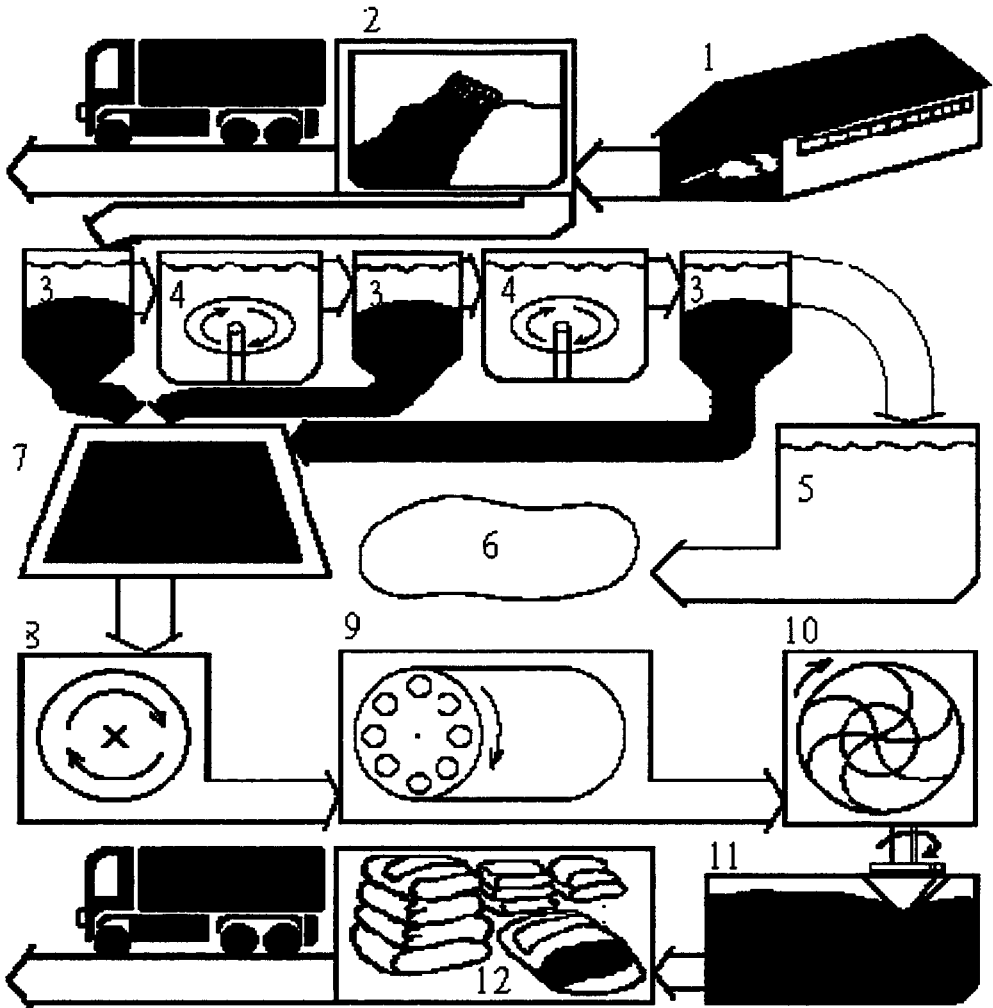

**Figure.1.**

*The process scheme of the treatment of wastes from the pig-farm complexes  
(54-216 thousand pigs):*

- 1-pigsty; 2-vibroscreen; 3-settler; 4-aerotank; 5-biopond;
- 6-water basin; 7-accumulator of sludges and deposits;
- 8-centrifuge; 9,10-drier-granulator; 11-bunker for storing Bamil;
- 12-packing line

## 2. Results

In 1986 - 1997 the trials of Bamil were conducted under greenhouse and field conditions on various crops: potato, tomato, pepper, wheat, lettuce, cabbage and others. Bamil stably enhanced the yield of potato by 10-15 t/ha, the hay of the perennial grasses - by 7 - 8, the wheat in an after effect - 0.8 - 1 t/ha and had a lasting after effect from 3 to 4 years. In sheltered grounds the yield of pepper increased by 25-70%; tomato - by 30%; lettuce - by 150-200%. Simultaneously, Bamil improved the agricultural product quality. Thus, the potato tubers showed a 6% increase in the starch content, Vitamin C had a 1.5-fold increase, the content of protein in the oats grains increased by 2-3%, in the wheat grains - by 1-1.4%. In the grown products the content of the nitrate nitrogen was considerably lower the admissible standards.

A stimulating effect of Bamil on the growth and development of plants was revealed. A considerable increase in the biological activity of the soil especially in the root zone was observed. The amount of active microorganisms-growth stimulators had a 2-3 fold increase.

The number of the soil infusoria (g.Oxtrichia, g.Colpoda, g.Cryptolophorus, g.Spathidinum) in variants with Bamil had a 5-8 fold increase as compared with the control variants.

Bamil easily mineralizes and increases the soil humus content, improves its physiological and chemical properties. Bamil is especially effective on the soils with a low humus content, particularly on soddy podzolic soils. Here the content of water soluble carbon has a 2-2.5 fold increase,  $N-NO_3$  - a 8-10 fold increase;  $N-NH_4$  - a 1.5-2.0 fold increase (Fig.2). Simultaneously, a sharp increase in the soil biological activity is observed: release of  $CO_2$  becomes two times as great, the number of the soil bacteria participating in the cycle of the nitrogen containing compounds degradation increases: the ammonifiers have a 6-10 fold increase, those utilizing the nitrogen mineral compounds become 2-4 times as great, those utilizing easily accessible organic compounds have a 2-3 fold increase. The number of cellulolytic microorganisms becomes greater by an order, the number of actinomycetes has a 1.5 fold increase. (Fig.3).

The study and analysis of the mechanism of the effect of the biofertilizer Bamil on the phytopathogenic microorganisms causing the plant diseases showed that in the biofertilizer the prevailing are aerobic bacteria which are capable of producing antibiotics. The microorganisms isolated from Bamil were studied by their antagonistic activity against a number of phytopathogenic fungi and bacteria which cause the plant diseases under the conditions of the Baltic Region. The results are presented in Table 2 from which it is clearly seen that the microflora of Bamil belongs to the antagonists to the number of phytopathogenic fungi and bacteria

which cause such plant diseases as root and stem rot, grey and soft rot, vascular wilt of plants.

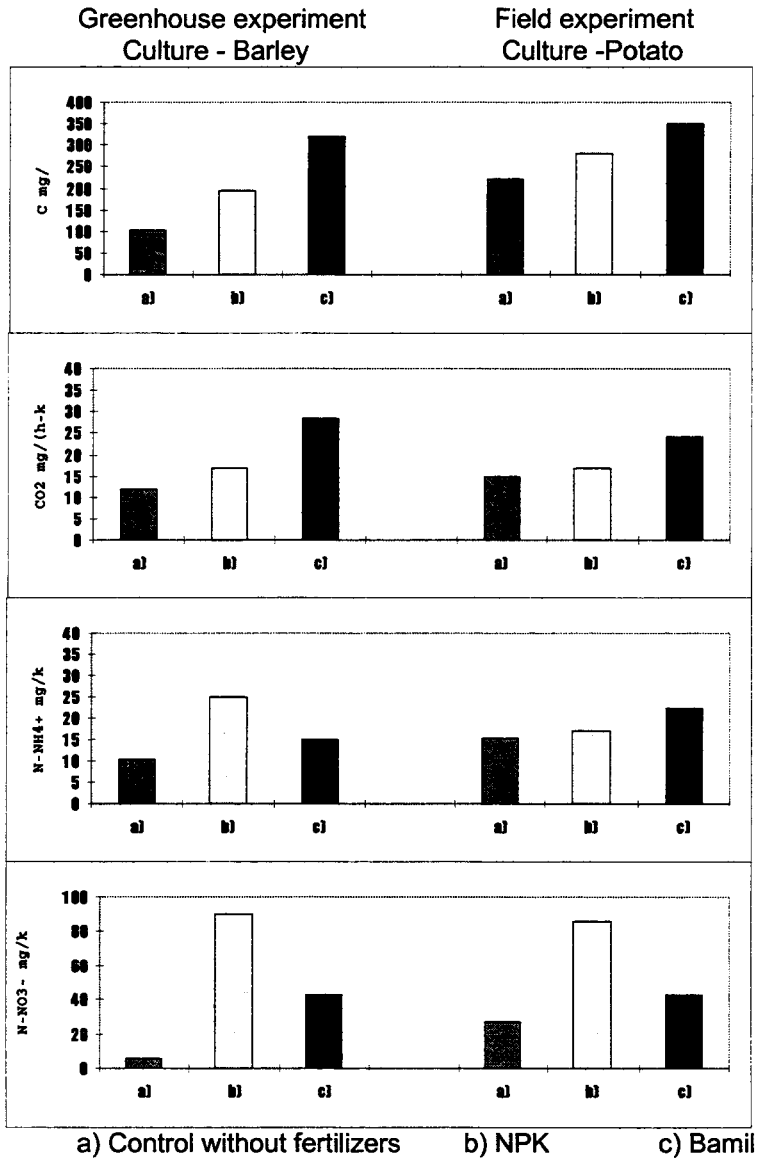
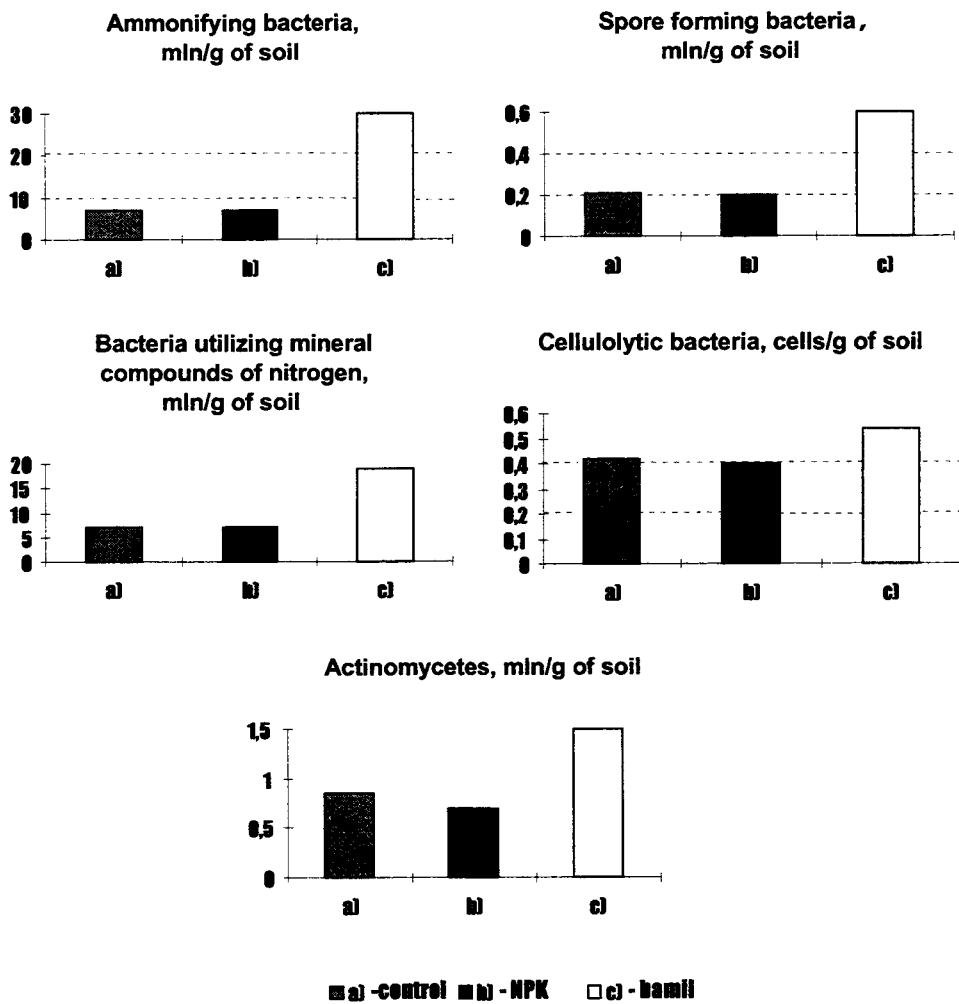

Figure 2

*Effect of Bamil on agrochemical characteristics of podzolic soil. The doses of fertilizers in a pot experiment calculated as 0,1 g of acting substance of total nitrogen/kg of soil, in the field experiment N100, P80, K100, manure and Bamil are equivalent to this dose of NPK.*



*Figure 3*  
*Effect of Bamil on the soil microflora (field experiment).*

Test of the culture of phytopathogenic fungi and bacteria	N of the strains of microorganisms in Bamil																			
	1	2	4	5	6	8	9	10	11	12	13	17	18	19	20	22	23	24	25	26
<i>Erwinia carotovora</i> C78								+												
<i>E. carotovora</i> P884		+						+								+				
<i>Alternaria</i> sp.24		+	+			+	+													
<i>Botrytis cinerea</i> 24		+		+		+		+	+	+			+		+	+				
<i>Verticillium dahliae</i> 289		+				+			+				+							
<i>Fusarium oxysporum</i> 98		+				+	+	+				+	+		+					
<i>Fusarium oxysporum</i> 99						+		+				+	+		+					

**Table 2.**

*Antagonistic activity of microorganisms isolated from Bamil against a number of phytopathogenic fungi and bacteria causing the plant diseases under the conditions of the Baltic Region.*

Proceeding from the literature data and our results we supposed a presence in Bamil of physiologically active compounds which stimulate the plant growth. The water extracts of Bamil were analyzed using the method of a highly effective liquid chromatography. It has been established that the water extract of Bamil may be divided into two fractions: low molecular (amino acids: tryptophan, tyrosine, phenylalanine) and high molecular (proteins containing tryptophan). Tryptophan is a predecessor of indoleacetic-3 acid (IAA) - auxin which is a plant growth stimulator. The results of the quantitative analysis of a free L-tryptophan in the examined samples of the fertilizers show that the content of L-tryptophan in Bamil constitutes 240 Mg/g, Bamil contains more tryptophan than the microbial fertilizers from the poultry dung - 72 Mg/g.

Of interest was to determine the effect of Bamil on the synthesis of IAA by the soil microflora. The object chosen was the soil with a 5% addition of Bamil. The soil was incubated for 6 days at 28 C. The control soil did not contain Bamil and was incubated under the same conditions. Extraction of IAA from the soil samples was done with a phosphate buffer with their following purification at a forcolumn BAKERBOND Octadecyl (C18). The methanol eluat from the forcolumn was evaporated at a rotor evaporator till it became dry and dissolved it in 0.5 ml of methanol. The amount of IAA in the soil samples was determined by an HPLC method at the apparatus JASCLC-900. For separation a reverse phase coulumn Li Chosorb RP-18 was used. As an eluent a mixture water-acetonitrile-acetic acid was



used. The rate of the eluent supply was 0.9 ml/min, the temperature of the column - 34 C. No IAA was found in the soil without Bamil additive, the amount of IAA calculated from the obtained chromatogrammes in the variant with Bamil was 46.3 ng/g which is sufficient for manifestation of the biological activity of the auxin.

Thus, application of Bamil to the soil promotes the biosynthesis of auxins by the soil microflora due to the presence of tryptophan in it. The revealed peculiarities of polyfunctional action of the biofertilizer Bamil enable us to suppose that the microbial fertilizers produced from the animal breeding wastes will take one of the chief places in a sustainable agriculture.

The work was financed by The Ministry of Science of Russia (The Projects "Bamil" and "Microbial communities").

### **3. References**

1. **Arhipchenko I.A., Miller B.B.** "Method for producing a biologically active fertilizer". (Patent of Russia N 1757209, 1992).
2. **Arhipchenko I.A., Banina N.N.**, 1995. "Active silt biocenosis of pig fattening complex sewage disposal system". Biology bulletin of Russian Academy of Sciences. 1;97-104.

## **Application of zeolite (clinoptilolite) in the process of stabilization of the solid fraction of pig slurry.**

*Apport de zéolite (clinoptilolite) afin de procéder à la stabilisation de la fraction solide du lisier de porc.*

**Vargová M., Ondrašovičová O.,  
Ondrašovič M., Para**  
University of Veterinary Medicine,  
Komenského 73, 041 81 Kosice.  
Slovak Republic.

**Venglovský J. Sasáková N.**  
Research Institute of Experimental  
Veterinary Medicine, Hlinkova 1/A, 040  
01 Kosice.  
Slovak Republic.

### **Abstract**

*The effects of two different additions (1% and 10%) of Slovak zeolite (clinoptilolite) to the solid fraction of pig slurry was investigated under laboratory conditions. Temperature in different depth of the substrate was recorded for 42 days. Chemical and microbiological determinations of the substrates and their water extracts were carried out. The results obtained indicated some dose dependent influence of zeolite amendment on decomposition processes reflected mostly in the temperatures recorded, dry matter content and  $N_{total}$  values. The temperatures recorded in the lower third of the substrate were higher in the first stage of stabilisation for the lower addition of zeolite and in the second stage for the higher addition, in comparison with the control. The release of nutrients ( $N_{total}$ ,  $N-NH_4^+$ ) to water extract, pH and conductivity of extracts were affected, too. When compared to the control, the conductivity of water extracts determined on days 21 and 42 for the higher addition of zeolite was by 36% and 28% lower, resp., the content of ammonia nitrogen was decreased by 48% and 56%, resp., and that of total nitrogen by 43% and 47%, resp. The results obtained indicate that with regard to decomposition processes, the effects of the doses used differed, mainly in the initial stages of storage.*

Key words : zeolite (clinoptilolite), pig slurry, solid fraction, microbial decomposition.

### **Résumé**

L'effet de l'ajout de deux doses (1% et 10%) de zéolite slovaque (clinoptilolite) à la fraction solide d'un lisier de porc a été étudié en conditions de laboratoire. La température à différentes profondeurs a été enregistrée au cours d'une période de 42 jours. Des analyses chimiques et microbiologiques du substrat ainsi que d'extraits aqueux ont été effectués.

Les résultats obtenus suggèrent une relation et l'influence de l'ajout de zéolite sur le processus de décomposition, à travers notamment l'évolution de la température, du taux de matière sèche et de la teneur en azote total. Les températures enregistrées dans le substrat étaient supérieures avec ajout de zéolite. Le transfert d'éléments N-total et N-ammoniacal) vers la phase aqueuse, le pH ainsi que la conductivité étaient également modifiés suite à l'ajout de zéolite. Comparativement au substrat témoin, la conductivité des extraits aqueux a été mesurée après 21 et 42 jours pour l'addition forte de zéolite. La conductivité était inférieure de 36% et 28% respectivement, la teneur en N ammoniacal était réduite de 48% et 56% respectivement, et celle en N total de 43% et 47% respectivement aux 2 périodes de mesure.

L'influence de la dose de zéolite apporté est particulièrement importante dans l'étape initiale de stockage du substrat.

Mots-clés : zéolite (clinoptilolite), lisier porc, fraction solide, décomposition microbienne.

## 1. Introduction

Large-capacity pig farms produce large quantities of slurry with high concentration of organic substances and considerable microbial contamination. The majority of pig-production facilities have been developed with little planning and concern for the nuisance and pollution characteristics inherent with their operation [1]. Most of the slurry produced by large-capacity farms in Slovakia is treated in aerobic biological wastewater treatment plants. In the first stage of the treatment, slurry is separated to the solid and liquid fractions. The liquid fraction is treated biologically and discharged to water bodies. The solid fraction, which contains considerable number of microorganisms and endoparasite eggs, should be subjected to biothermic or some other treatment before it is used in plant production [2,3]. However, the treatment of this fraction in practice consists in many cases in simple stabilization on field heaps for different periods of time. This often results in the loss of nutrients and pollution of the environment.

The aim of the present study is to investigate the influence of different additions of zeolite (clinoptilolite) on the processes of microbial decomposition and stabilization of the solid fraction of pig slurry and release of nutrients from this substrate during its storage.

## 2. Material and methods

The solid fraction of pig slurry, obtained by separation on vibrating screens, was mixed with powder zeolite (clinoptilolite) from Ni ný Hrabovec, Slovakia (main fractions: 76.9% 0.125-0.25 mm, 10.8% 0.25-0.5 mm; CEC 0.77 mol.l<sup>-1</sup>; predried at 105°C), in 1:99 and 10:90 ratio. The mixtures obtained were transferred to glass cylinders (10.5 cm i.d., 60.4 cm high) with both ends opened, placed in a vertical position in a Petri dish (containers 2 and 3, resp.) and an unamended solid fraction was used as a control (container 1). The cylinders were covered with cellulose cotton wool to prevent excessive evaporation of water

The substrates were stored at room temperature (17.0-24.0°C) for 21 days. After that time, they were removed, thoroughly mixed, and 100 g samples were withdrawn. Then they were replaced to containers and stored for additional 21 days (18.0-27.2°C). During the storage, the temperatures in the upper third, centre, and the lower third of the substrates were recorded. The liquid that oozed out of the substrates during the first 24 hours of storage was collected and analysed.

Total nitrogen (N<sub>t</sub>), dry matter content (DM) and loss on ignition (550°C/2h) were determined in the solid fraction on day 0 and in all substrates after 21 and 42 days of storage. Simultaneously, determinations in water extracts were carried out (CO<sub>2</sub>-free distilled water; 5g+45ml H<sub>2</sub>O, diluted 1:2, for pH; 50g+250ml H<sub>2</sub>O for determinations of N<sub>t</sub>, N-NH<sub>4</sub><sup>+</sup> and conductivity).

N<sub>t</sub> was determined by distillation and titration of N-NH<sub>4</sub><sup>+</sup> after previous mineralization using a HACH-Digesdahl digestion apparatus, Model 23130-20. Distillation method was also used for determination of N-NH<sub>4</sub><sup>+</sup> in the extracts. Conductivity was measured by means of a HACH Conductivity/TDS meter, Model 44600, and pH by means of a HACH ONE pH meter, model 43800.

Along with chemical determinations, numbers of psychrophilic, mesophilic, coliform and fecal coliform microorganisms were determined in 1 g of the solid fraction and the results were published elsewhere.

## 3. Results and discussion

The purpose of stabilization of farmyard manure and solid portion of slurry is to break down the organic fraction in order to reduce its mass and to obtain a product that is less odourous as well as safer from a public health standpoint [4]. Degradation of organic matter is carried out by microorganisms under aerobic, moist, and warm conditions. In dependence on the conditions of the decomposition processes (temperature, aeration, moisture, pH, content of nutrients, type of material), organic matter is degraded at different rates at several temperature phases, each of which is driven by specific groups of organisms. At optimum conditions, the temperature in the core of the substrate may reach 55-60°C, which

is sufficient to inactivate pathogens and transform organic forms of N and P into inorganic forms, which are more bioavailable for uptake by agricultural crops [5].

Numerous applications of natural and synthetic zeolites have been described in different branches of industry and environmental protection. Majority of agricultural applications described concentrate on utilization of zeolites with regard to its high affinity for  $\text{N-NH}_4^+$  and some metal ions and are supported by chemical determinations. In horticultural applications, the improvement in N-balance and water retention in soil is stressed after ammendment of soil with zeolites resulting in growth enhancement or yield increase of crops.

However, there are few publications in which the effects of zeolites or similar amendments are described in relation to the activity of microorganisms and acceleration or deceleration of decomposition processes [6,7].

The clinoptilolite framework consists of interconnected channels with voids big enough for water and adsorption of some ions but too small for viruses and bacteria to enter [8]. By retaining  $\text{N-NH}_4^+$  ions, clinoptilolite improves efficiency in N-uptake by preventing excessive nitrification and  $\text{NO}_3^-$  leaching and helps to reduce  $\text{NH}_4^+$  toxicity. In contrast with that, organic matter sources like peat, used as soil amendments, improve cation exchange capacity of soil but easily release ammonium ions from their exchange sites, which are then easily nitrified and thus, subjected to leaching [9].

The results obtained in our study indicate that the zeolite amendment affected the decomposition processes in the substrate investigated. During the 42 days of storage, all the substrates changed considerably and practically lost their characteristic unpleasant smell.

According to some authors [10,11], the DM content in the solid fraction obtained by separation on vibrating screens should range from 18 to about 40%. The DM content in our study was 15.75% and some retained liquid oozed out of this material during the first 24 hours of storage. The volume of the liquid released was decreased by 2.2% and 15.2% by 1% and 10% zeolite additions, respectively. Chemical analysis showed considerable differences in the parameters determined (Table 1) for original and amended solid fractions. Addition of zeolite decreased the content of  $\text{N}_t$ ,  $\text{N-NH}_4^+$  and electrolytic conductivity which is related to the concentration of inorganic dissolved solids, anions and cations.

	Control	1% zeolite	10% zeolite
Conductivity [ $\text{mS}\cdot\text{cm}^{-1}$ ]	3,83	3,55	295,00
$\text{N}_{\text{total}}$ [ $\text{mg}\cdot\text{l}^{-1}$ ]	4 132,00	4 097,00	3 012,00
$\text{N-NH}_4^+$ [ $\text{mg}\cdot\text{l}^{-1}$ ]	3 082,00	2 976,00	2 521,00

Table 1

*Analysis of the liquid released from the stored solid fraction within 24 hrs of storage*

Results of chemical analysis of the solid fraction of pig slurry and amended substrates as well as of water extracts at the beginning of the experiments and after the storage for 21 and 42 days are summarised in Tables 2 and 3. Visible differences in the colour of water extracts were observed after 42 days of storage. The extract of substrate 2 (1% zeolite) was dark-brown while that of the control (substrate 1) was yellow-brown. Grayish colouration of the extract of substrate 3 (10% zeolite) resulted from the presence of zeolite particles.

Container	1	2	3	1	2	3
	Dry matter (DM) [%]			Loss on ignition [%DM]		
Day 0	15,75			89,64		
21 days	21,42	22,38	32,78	89,02	88,75	51,78
42 days	22,10	22,34	33,89	86,90	81,10	46,93
	N <sub>total</sub> [mg.kg <sup>-1</sup> ]					
Day 0	7018					
21 days	6445	5858	6152			
42 days	3979	4501	4487			

*Table 2*  
*Results of chemical determinations in the solid fraction of pig slurry and amended substrates*

Container	1	2	3	1	2	3
	pH			Conductivity [mS.cm <sup>-1</sup> ]		
Day 0	7,67			4,36		
21 days	8,09	6,96	6,19	2,64	2,57	1,69
42 days	8,46	6,82	6,82	2,22	2,00	1,60
	N <sub>total</sub> * [mg.l <sup>-1</sup> ]			N-NH <sub>4</sub> <sup>+</sup> * [mg.l <sup>-1</sup> ]		
Day 0	672,3			543,5		
21 days	403,4	316,5	230,7	262,6	196,8	135,5
42 days	22,4	72,1	11,9	3,4	3,3	1,5

\*Results were corrected for DM content

*Table 3*  
*Determination of chemical parameters in water extracts*

The temperatures reached in the substrate exceeded the ambient temperature only by max. 2.4°C. The explanation may be found in the small quantity of the substrate and excessive moisture in its core exceeding the range 50-60%, optimal for the biothermic activity of different groups of microorganisms.

The course of temperatures differed in dependence on the depth of measurement and on the zeolite dose. In the surface layer, slightly higher temperatures were recorded in the zeolite amended substrates in comparison with the control during the most of first 21 days. The differences were more pronounced for the higher

dose of zeolite (0.3-0.9°C; 0.5-1.5°C). After mixing, minimum variations around the control values were recorded.

In the centre of the substrate, for the lower dose of zeolite, the temperatures were higher by 0.3-1.0°C in comparison with the control only during the first 8 days and after that only small variations (0.1-0.2°C) were recorded always to the end. For the higher dose of zeolite, lower than control temperatures were recorded for the first 15 days (by 0.5-1.4°C), after which the temperatures increased and remained close to those recorded in the control with only small variations.

The highest differences in comparison with the control were observed in the lower third of the substrate (Figure 1). Very interesting was the course of temperatures for the lower dose of zeolite. Almost from the beginning up to day 21 (mixing), they exceeded those in the substrate with 10% zeolite and after that an opposite trend was observed.

**The course of temperature in the lower third of the substrate**

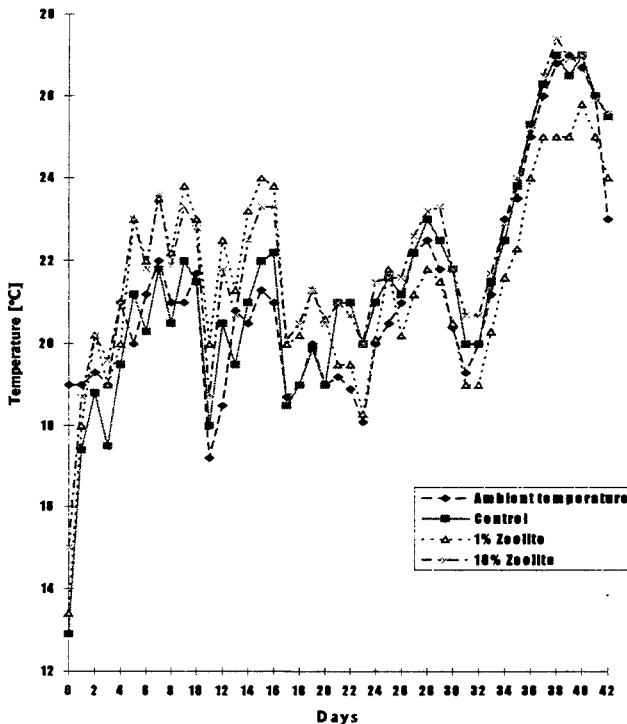

Figure 1

To confirm and explain this observation, additional investigations with larger quantity of the substrate are needed. However, the results of microbiological and chemical examination indicate that with regard to decomposition processes and therefore also the activity of microorganisms, the effects of the doses used differed, mainly in the initial stages of storage. The pH values measured support this assumption as well as the  $N_{\text{total}}$  values. The adsorption and ion exchange properties of zeolites were reflected in the decrease in conductivity, ammonia nitrogen and  $N_{\text{total}}$  in the water extracts and liquid that oozed out of the substrates. However, the results available provide no explanation for the change in the loss on ignition recorded after 10% addition of zeolite.

#### 4. Conclusion

The addition of 1% and 10% zeolite (clinoptilolite) to the solid fraction of liquid slurry obtained by mechanical separation in the first stage of the slurry treatment caused changes in the release of nutrients to water extracts during the 42 days of storage and in their concentration in the fluid that oozed out of the solid fraction. A dose dependent effect on the decomposition processes was indicated.

The results presented in this paper were obtained within the scope of solving the projects No. 95/5195/575 and 1096/94.

#### 5. References

- [1] **BICUDO, R. J., SVOBODA, I. F.:** Effect of intermittent-cycle extended-aeration treatment on the fate of carbonaceous material in pig slurry. *Bioresource Technology*, 54, 1995: 53-62.
- [2] **JURIŠ, P. a kol.:** Dissemination and survival of endoparasites in the environment (In Slovak). *Vet. Med.-Czech.*, 36, 1991: 665-671.
- [3] **PLACHY, P., JURIS P., PLACHA, I., VENGLOVSKY, J.:** Use of hydrated lime for disinfection of model pathogens *Salmonella typhimurium* and *Ascaris suum* in sewage sludge (In Slovak). *Vet. Med.-Czech*, 41, 1996 (8): 255-259.
- [4] **KILLHAM, K.:** Soil ecology. Cambridge University Press, 1994: 241 s.
- [5] **BITTON, G.:** Wastewater microbiology, Willey/Liss, Inc., New York, 1994: 478 s.
- [6] **PAĚAJOVÁ, Z. a kol.:** The influence of natural zeolite on the survival of various groups of microorganisms at different temperatures (In Slovak). In: Proc. "Ecology and veterinary medicine III.", Košice, SR, May, 1996: 163-167.



[7] **PICHTEL, J.R., HAYES, J.M.:** Influence of fly ash on Soil Microbial Activity and Populations. *J. Environ. Qual.*, 19, 1990, 593-597.

[8] **MUMPTON, F.A., FISHMAN, P.H.:** The application of natural zeolites in animal science and aquaculture. *J. Anim. Sci.*, 45, 1977:1188-1203.

[9] **HUANG, Z. T., PETROVIC, A. M.:** Clinoptilolite zeolite influence on nitrate leaching and nitrogen use efficiency in simulated sand based golf greens. *J. Environ. Qual.*, 23, 1994: 1190-1194.

[10] **JONÁŠ, J. - PETŮÍKOVÁ, V.:** Utilization of farm animal excrements (In Czech). SZN Prague, 1988: 184 s.

[11] **STEHLÍK, K.:** Utilization of wastewaters for irrigation (In Czech). In: Liquid farm manure and agricultural wastewaters. MZV ĚSR, Prague 1988, 438s.

## Physical characterisation of animal manure.

Caractérisation physique du fumier.

**F. Thirion, F. Chabot, D. Andeler**

Cemagref Domaine des Palaquins - 03150 MONTOLDRE. France

Phone 33 (0)4 70 45 03 12 FAX 33 (0)4 70 45 19 46

e-mail francois.thirion@cemagref.fr

### Abstract

*The great variability of animal manure characteristics is due to the large diversity of livestock, storage type and handling equipment. The performance of a spreader is directly related to the physical properties of the material being spread out. When testing a spreader or researching spreading techniques, it is necessary to know the main physical characteristics of the manure.*

*The Swedish Institute of Agricultural Engineering has already developed a characterisation method. The implementation of their method has highlighted the necessity of increasing the number of factors measured and selecting equipment that may be used easily in the field. Cemagref have designed and tested measuring equipment specific for this purpose. A combination of 6 measurements has been set up for each heap of manure :*

- . Bulk density : weight of a bucket.*
- . Cohesion : use of a penetrometer.*
- . Shear stress resistance : use of a scissometer.*
- . Dry matter content : use of an oven.*
- . Straw content.*
- . Friction coefficient : use of an inclined plane.*

*These measurements have been carried out on 25 different types of manure. An heterogeneity coefficient has been determined based on several points of the graph obtained with the penetrometer at depths from 25 centimetres to 60 centimetres below the surface. Results were then compared to determine the main characteristics of each type of manure.*

*To confirm the usefulness of these measurements we analysed the relationship between these measures and the performance of the spreader. Three main relationships have been verified :*

- . *density and discharge rate,*
- . *shear stress resistance and drive torque,*
- . *heterogeneity and spreading precision.*

Keywords : *manure, spreader, density, heterogeneity.*

## Résumé

La structure des fumiers présente de grandes variations en raison de la diversité des animaux, des stockages et des moyens de manutention. Les performances des épandeurs de fumier dépendent des propriétés du produit épandu. Il est donc nécessaire pour le Cemagref de déterminer les principales propriétés physiques du fumier lors des essais d'épandeur ou en vue de recherches sur l'épandage.

Le « Swedish Institute of Agricultural Engineering » a défini une méthode de caractérisation. La mise en oeuvre de cette méthode nous a montré le besoin d'augmenter le nombre de critères à mesurer et de choisir des moyens de mesure utilisables au champ. Nous avons défini et testé des appareils de mesure spécifiques. Un ensemble de 6 mesures a été retenu pour chaque tas de fumier :

- . Densité : pesée de seaux.
- . Cohésion : utilisation du pénétromètre.
- . Résistance au cisaillement : utilisation du scissomètre.
- . Taux de matière sèche : séchage à l'étuve.
- . Richesse en paille.
- . Coefficient de frottement : plan incliné.

Ces mesures ont été effectuées sur 25 fumiers différents. Nous avons défini un coefficient d'hétérogénéité, à partir des courbes du pénétromètre sur une profondeur de 20 à 65 cm. Les résultats ont été comparés afin de dégager les propriétés générales des types de fumier correspondants.

Pour justifier l'intérêt de ces mesures de caractérisation, nous avons cherché leur relation avec les performances d'un épandeur. Trois relations principales ont fait l'objet de vérifications :

- . densité et débit,
- . résistance au cisaillement et couple d'entraînement,
- . hétérogénéité et précision d'épandage.

Mots-clés : fumier, épandeur, densité, hétérogénéité.

# 1 Introduction

The physical characteristics of solid manure cannot be defined simply according to its origin. Many factors may impact on these characteristics: for example, in the same shed, the density may vary from  $400 \text{ kg/m}^3$  where the cattle is used to rest, to  $700 \text{ kg/m}^3$  where the movement of cattle has compacted the manure.

This paper will describe a method for physical characterisation of solid animal manure. Cemagref wants to develop methods for testing manure spreaders and also wants to improve the working of machines. An agricultural machine has several components that work together as a system in order for the machine to perform in the intended manner. The manure spreader has to meter the manure quantity and to spread it in an even flow on a longitudinal way than as well as on a transversal way. Each function depends on the manure characteristics in a way that we are not able to quantify now.

The Swedish Institute of Agricultural Engineering has already developed a method of manure characterisation, mainly for equipment testing purposes. We encountered several difficulties when we wanted to implement these methods. These methods have actually been set up in a research institute where large facilities are available for handling the manure. The handling equipment that we use in our institute is not reliable for this purpose, and for example it was not possible to fill up a characterisation box of  $1 \text{ m}^3$  with this equipment. Another point is that the manure seems to be different under Swedish or French conditions. Under French conditions, straw is widely used in sheds, and it appears that this straw will widely change the physical properties of the manure. For example we intend to verify that manure density is connected to straw content, whereas under Swedish conditions it has been verified that manure density is mainly related to dry matter content.

Six tests have been defined for each manure heap, and tests have been carried out on the farms except for the dry matter content measurement which has needed samples to be brought back to the institute. It was then necessary to investigate whether the performances of the manure spreader are related to the manure physical characteristics. It is sure that the discharge rate is connected with density of the manure, as the delivery principle is based on the volume of the manure that has to be spread. Physical characteristics may also interfere with evenness of the spreading and power needed to work out the machine. These data are necessary when testing spreaders or implementing research on spreading techniques.

## 2. Definition of characterisation tests

### 2.1 Normal stress measurement

Penetrometers were used for this purpose. A penetrometer is an equipment usually fitted for measuring the soil cohesion. A conical tip is driven into the soil and the strength is measured either by a pressure gauge or by the length of a spring. We have selected the mechanical principle and used a set of 2 tips with a diameter larger than the one originally fitted. A pencil is fitted on this equipment in order to draw a continuous graph which indicates the value of the normal stress at each depth in the manure. The main advantage of this measurement is the ability to get data of physical characteristics inside the manure heap and also to get easily a large amount of data that may be analysed.

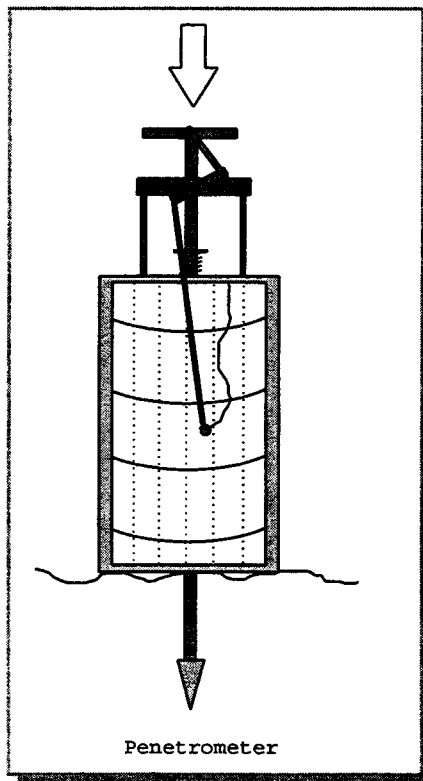

$$\text{Normal stress: } \sigma = \frac{F}{S} = \frac{F}{\pi R^2}$$

F = Force ; S = Surface

## 2.2. Measurement of shear stress

We have selected a shear vane apparatus. This equipment does not require excavation. Once driven into the manure by a hammer, the rotation causes shear of manure along the surface which is generated by the vanes. The torque which is necessary to rotate the device is measured by a torque wrench.

Sheared area:  $S = 2\pi rh$  ( we consider that a cylinder of manure is sheared from the manure kept inside the system.)

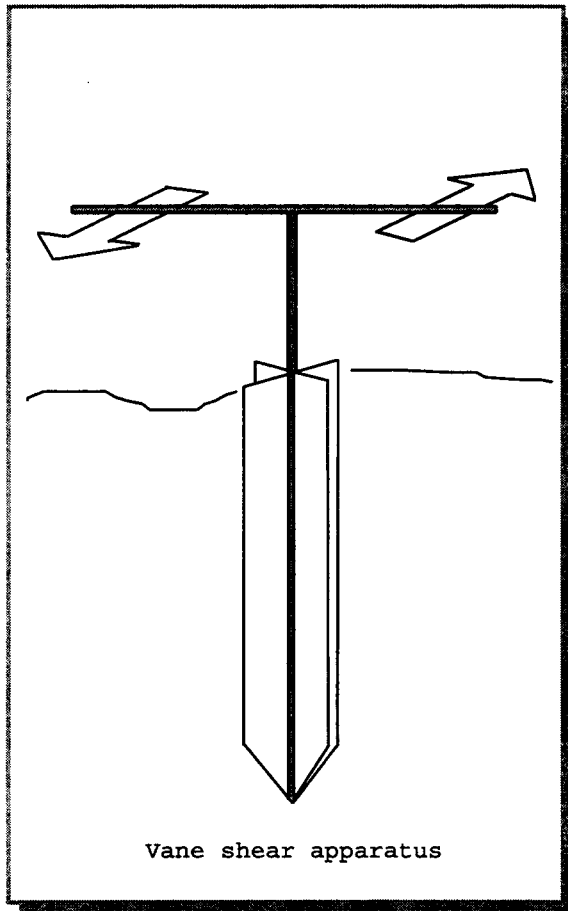

Torque:  $M$

$$\text{Shear stress: } \tau = \frac{M}{R \cdot 2\pi rh}$$

$M$  = Torque.  $R$  = Torque application radius.  $r$  = Shear radius

### 2.3 Measurement of bulk density

The main problem in measuring bulk density is to define the conditions of measurement. At first we intended to define density of manure inside the heap. For this purpose a volume of manure inside the heap was separated by sheets of metal driven into the manure. By this way, we could determine a volume of manure and we dug out this manure to weigh it. It is also possible to separate a volume by the mean of the tractor loader. This volume is measured and the manure is loaded in a spreader and weighed.

It is easier to measure the weight of the manure after having handled it. Swedish method needs to fill up a characterisation box of approximately  $1 \text{ m}^3$  volume, with the tractor loader. The purpose of this is to get similar conditions when using the characterisation box or when using a spreader. We tried also to fill up this box by hand with a fork. The results of these two measurements will depend on the way of filling the box.

Another way of measuring the bulk density is to fill up the spreader and weigh it. Main difficulty is to know the volume of the spreader, as the shape of the machine may be complicated. This way of measurement gives certainly the most interesting information when we want to study the performance of the spreader.

We selected another measurement for our field test. We fill up a bucket by hand and let it fall 3 times from 30 cm high in order to get similar compaction. We fill it up again.

Example: we analysed a 35 tons batch of manure:

method of measurement	density
separation of $1.8 \text{ m}^3$	$944 \text{ kg/ m}^3$
separation of $3.6 \text{ m}^3$	$798 \text{ kg/ m}^3$
separation of $6.2 \text{ m}^3$	$795 \text{ kg/ m}^3$
$1 \text{ m}^3$ box filled by hand	$405 \text{ kg/ m}^3$
$1 \text{ m}^3$ box filled by hand + compressing	$650 \text{ kg/ m}^3$
manure in the spreader ( $7 \text{ m}^3$ )	450 to $650 \text{ kg/ m}^3$

It appears that the density variability is great in the same batch. When building this heap by means of a tractor loader, the farmer has created blocks of manure of high density separated by low density spaces. When handling the manure by hand the volume increases and the density decreases in a range of approximately 50%. When handling the manure by a tractor loader, the density depends on the way this implement is used and the density has been observed from 55% to 80 % of the manure density in the heap.

When measuring the density with buckets we observe also a large range of results. The expansion which is created by this method is similar with the one obtained by tractor loader. This value may be used to compare several types of manure, but not to know what will be the density inside the manure spreader. The measurement is repeated 4 times.

## **2.4 Friction coefficient**

A sample of manure is placed on a plane surface which is slowly inclined. When the manure slips, the angle is measured. The purpose of this measurement is to verify whether the strength used to push the manure inside the spreader is connected to the friction coefficient. Actually this strength depends on 2 factors: the friction between the manure and the floor of the spreader, and the resistance of the manure being dislocated: The moving floor of the spreader acts on the manure in order to obtain a good dislocation by the beaters acting rearwards.

## **2.5 Straw content**

It was not possible to define a method for direct measurement of the straw content. In order to get an indication concerning this factor, we decided to measure the length of 40 pieces of straw. The main advantage of this method is that it does not take account of small pieces of straw, as small parts of straw do not seem to modify the physical characteristics of the manure. Long pieces of straw increase the volume of the manure and reduce the density. Straw is also increasing the resistance to dislocation. For these reasons, we have chosen this particular measurement which appeared easy to do.

## **2.6 Dry matter content**

Samples of manure are dried in an oven during 24 hours at a temperature of 120 °C. The decrease of weight is due to water evaporation. The dry matter content is the ratio water content/ wet weight. Under Swedish conditions, dry matter content appeared to be an important factor.

# **3. Results of measurements**

In 1997, 25 sets of measurements have been worked out in French farms around Cemagref. All the data was collected and analysed afterwards.

## **3.1 Normal stress**

The normal stress appeared to vary from 0.14 MPa (1.4 bar) to more than 1.6 MPa (16 bar). The low resistances were met in compost, old manure. The high resistances were met inside heaps built by mean of a mechanical elevator or built



after transportation in the fields. Sheep and goat manure have also a high resistance: In one case, it was not possible to use the penetrometer as the manure was very hard.

With the help of the graphs obtained from the penetrometer we introduced a new characterisation factor: For each graph, we consider the stress at 4 different depths: 35, 45, 55, and 65 cm. We obtain 4 values for each graph and compute the variation coefficient of these values. The heterogeneity coefficient is defined as the mean value of these 4 variation coefficients. By this way, it is possible to obtain a numerical value of heterogeneity. This value is consistant with physical properties inside the heap.

The lowest values were found in compost (9%) and in a 2 years old heap of manure (15%). Low value were also found in wet and soft heaps. Average values are around 30 to 40 %. High values (50 to 60 %) were observed in one heap built by tractor loader, and in another heap under chain cleaner. Major heterogeneities are observed in manure with high stress. This means that the manure has been compacted, but not in an uniform way.

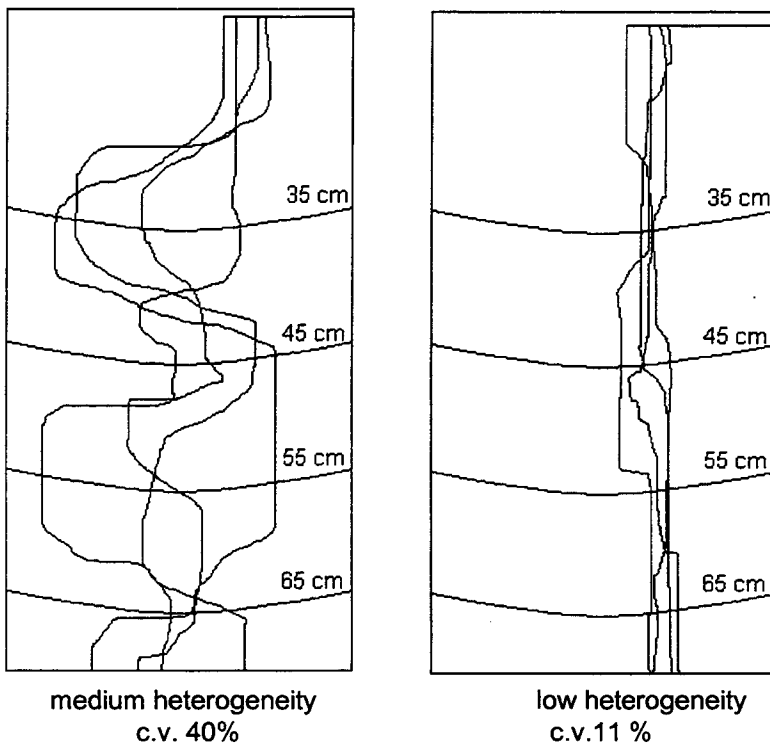

### 3.2 Shear stress

The shear stress appeared to vary from 3 kPa to 50 kPa. One problem appeared with manure with high content of straw. When driving the apparatus into the manure a plug of straw is created. This plug enlarges the hole and the apparatus turns quite freely in this hole. For this reason the measurement is not entirely reliable and it is more advisable not to use this measurement when long pieces of straw are present in the manure.

### 3.3 Bulk density

We observed that the bulk density depends on 2 separate factors. In the same farm, with manure obtained from similar animals, the density depends mainly on the straw length. The dry matter content is quite constant, the length of straw depends on the type of shed, the age of the manure and the location in the shed.

If we compare the sample of manure for a large variety of origins (animals, housing, etc) the range of density is wide and the density mainly depends on dry matter content.

**Density / straw length  
(in the same farm)**

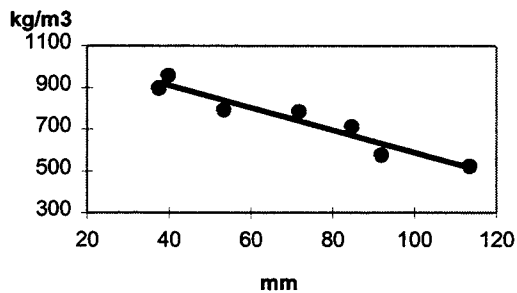

**Density / dry matter  
(different farms)**

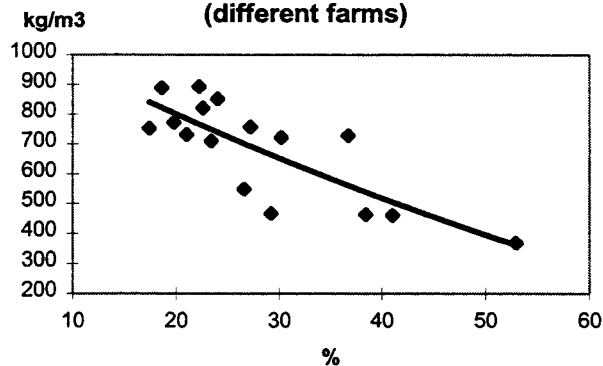

Some other measurements have been made in several regions of France, based on manure density inside the spreader. The point was to help the farmers adjusting the spreader as it should be necessary to know the density in the spreader when adjusting it. High densities ( $900 \text{ kg/m}^3$  to  $1000 \text{ kg/m}^3$ ) are found in heaps built by chain cleaner, close to the centre of this heap. Amassed litter bedding in the sheds gives also high density manure especially when stored in the fields in high heaps. Low densities are mainly observed with chicken manure ( $300 \text{ kg/m}^3$ )

### **3.4 Straw length**

Straw length measurement appeared to be well connected with straw content influence. We have seen how this result is linked to bulk density. We have observed also the variation of this factor during composting operation. The compost was obtained by using a spreader. A first ridge was obtained by operating the spreader in an idle position. This operation was repeated a second time after 15 days.

Original manure 113 mm  
After 1 operation 89.7 mm  
composted 37 mm

The second length can be explained by the slashing of the straw in the beaters of the spreader.

We observed also in a 2 years old heap of manure that the mean straw length was 39.8 mm in the upper part of the heap but was 53.4mm in the lower part. In the upper part of the heap the manure is aerated and the manure is slowly composted.

### **3.5 Friction coefficient**

For most samples of manure the angle of the inclined plane is about 40 degrees when the manure begins to slip. This means that the friction coefficient is  $f = \tan 40 = 0.84$

One sticky manure was observed with 1.70 as friction coefficient, but this was an exception. It was not possible to identify classes of manure in order to study the influence of the friction coefficient on power requirement for the conveyor of the spreader.

### **3.6 Dry matter content**

There is a large variety of dry matter content, from 16 % to 53%. High moisture may be due to rainfall. There is usually no protection on manure heaps, but the storage of run-off is compulsory. Sheeps and goats manure is drier than cows manure. Chicken manure of chickens is also dry.

## **4 Influence of manure characteristics on the working of the spreader**

**4.1 Bulk density** is the main factor having an influence on the working of the machine. The discharge principle is based on determination of a volume which is spread per unit of time. The Swedish institute has verified that the discharge rate is directly connected to bulk density measured in a characterisation box of 1 m<sup>3</sup> volume. In France, it is recommended to weigh the manure in a bucket in order to improve the adjustment of the spreader. As for us we are working on an integrated weighing system incorporated in the manure spreader in order to regulate the discharge rate according to the variation of density.

### **4.2 Shear stress**

A new system of discharge regulation is based on torque measurement in the driving of the spreading beaters. We intended to verify whether the torque depends on the discharge rate only, or on the shear stress also. We have measured the torque used for driving the beaters and driving the whole conveyor, with three types of manure: compost, old manure and new manure selected according to the shear stress (10, 16 and 23 kPa). We observed that the power which is necessary to drive the beaters is lower with compost (4,1kW) and old manure (4,8kW) than with new manure (5,7kW). The variation of power on the beaters are directly induced to the power used to drive the conveyor. This means that the beaters push backwards the manure, with a strength depending on the shear stress.

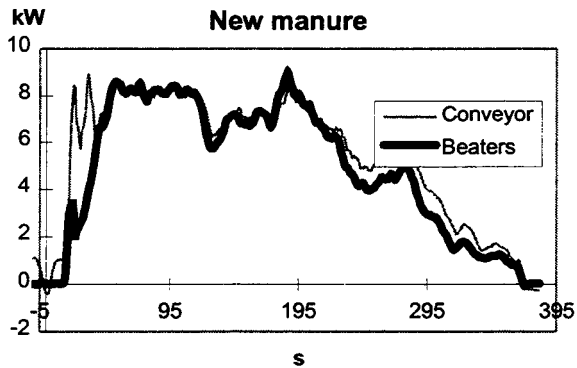
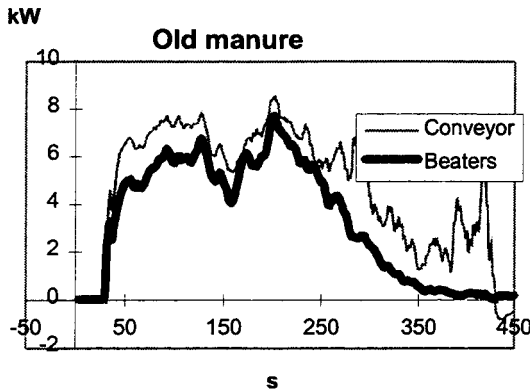

Power used to drive the spreader for old manure and new manure

According to these observations, it is not possible to estimate the discharge rate from the torque value only, when we deal with different types of manure or compost.

#### 4.5 Manure heterogeneity

We have used 2 types of manure with the same spreader and the same adjustment. One manure was quite heterogeneous (variation coefficient 49%) the other had a low variation coefficient (9 %) measured with the penetrometer. The variation of quantity spread along a transversal way was measured by the means of trays disposed on the soil. The measurement was repeated 4 times. We obtained a low quality of spreading with the first equipment (29% variation) and a good quality with the second one (8% variation)

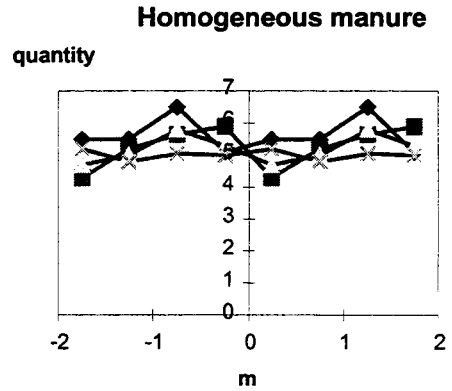
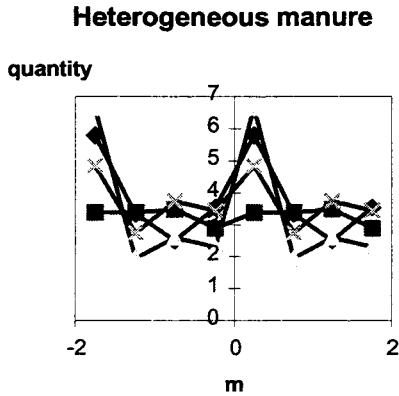

This means that it is very important to verify the heterogeneity of manure when we want to test several spreaders or when we need to assess a spreader performance.

## 5. Conclusion

This study has outlined the influence of manure heterogeneity and proposes an easy mean of getting a numerical value of this heterogeneity. A comprehensive test allows to characterise a manure batch and will avoid hazardous conclusions on spreader tests, especially when different manures have been used.

## 6. References

**Malgeryd J; Wetterberg C** Physical properties of solid and liquid manures and their effects on the performance of spreading machine. *Journal of Agricultural Engineering Research*, 1996, **64**: 289-298.



**Chairman's summary of part 4.**  
**Processing and handling of wastes**  
**Piet DERIKX**

The session concentrated on different aspects of handling and processing wastes in general. Special attention was there for animal manure, but also other wastes came up.

Dr. Colin Burton from the Silsoe Research Institute (UK) gave a good overview of the state of the art of treatment techniques and management strategies. His presentation was mainly based upon a EU Concerted Action finished at the end of last year where a number of scientist of different European countries brought together up to date information about the situation in their home countries and developed thoughts about potential strategies for handling wastes in future. The resulting book is still available and can be obtained by addressing the presenter. One of the major points which were emphasised is the need to clearly define the targets of a treatment. Only then a optimal choice can be made of the many different possibilities for treatment.

Mr. F. Beline showed with his presentation that a good understanding of the processes involved in a treatment can help to optimise a treatment. Intermittent aeration was proven to give less nitrous oxide emission as compared with continuous aeration, without loss of nitrogen removal capacity.

Two presentation dealt with biogas production. For the treatment of slaughterhouse wastes this gas production was of second importance, as emphasise here were on lowering the additional treatment costs for the effluent and therefore BOD removal was of major concern, as presented by Dr. Massé. Dr. Amon showed the well documented situation in Austria, where biogas production plants are built not only taking into account technical criteria but also paying the required attention to safety aspects.

The biofilter remediation presented by Dr. Buelna was an illustrative example of successful treatment of two different waste flows at once. Exhaust air is cleaned and in addition nitrogen is removed from the slurry.

Prof. Matsuda from Hokkaido University in Japan demonstrated the effectiveness of the composting process on a semi-practical scale. Food industry wastes was broken down so far that the enterprise could be operated for over one year without the need to remove any residue from the reactor.

Dr. Vanotti showed that the use immobilised nitrifiers can improve the nitrifying capacity of a reactor for converting ammonia in swine wastewater.

Prof. Arkhipchenko demonstrated the fact that the need of advanced treatments is not limited to the western countries. Large livestock farms in Russia have similar



problems with manure surpluses. The biofertiliser BAMIL produced in the pilot plant is investigated thoroughly, demonstrating its beneficial effect on plant growth and soil fertility.

The addition of a zeolite to solid manure resulted in the adsorption of some ions, specifically ammonia. Additions up to 10 % were needed. As the adsorption is a reversible process, the ammonia will become available in a later stage.

Dr. Thirion demonstrated the need of detailed information in order to design spreading equipment. In particular solid manure was addressed with several physical measuring techniques.

In summary, the session demonstrated the wide range of techniques involved in waste treatment. The appropriate choice of a combination of these techniques highly depends on the local situation. Not in the least importance are the economic aspects, although the information available about this is limited at the research phase. What is economical feasible depends also on the options individual farmers have for achieving a balanced situation at their farm.

## **Part 5**

### **Environmental impacts.**

**Chairman : C. Cheverry (France)**

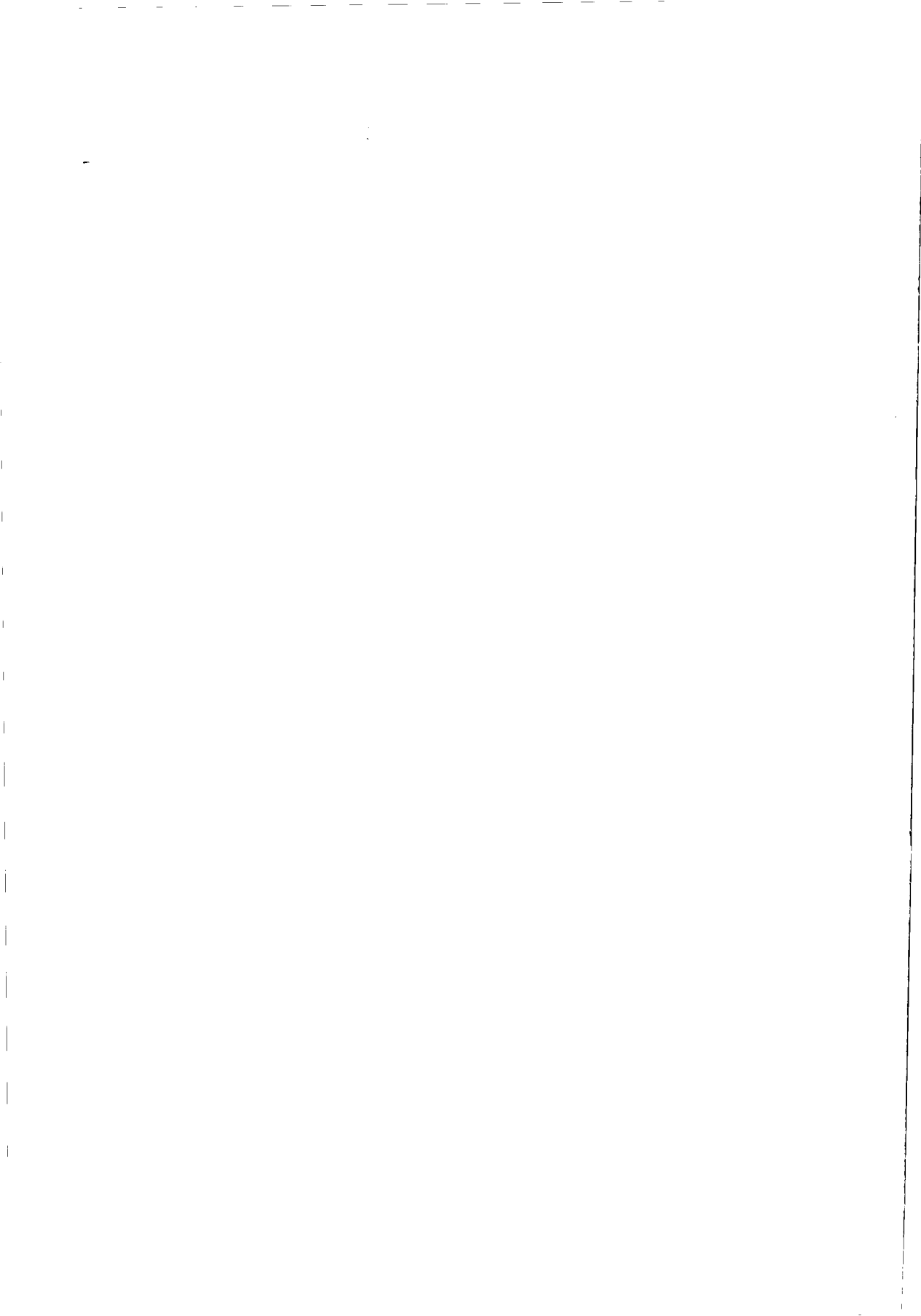

# Heavy metal loadings from animal manures to agricultural land in England and Wales.

*Charge en métaux lourds apportés aux sols par les épandages de déjections animales en Angleterre et Pays de Galle.*

**B. J. Chambers\***, F. A. Nicholson,  
**D.R. Soloman**  
ADAS Gleadthorpe Research Centre,  
Meden Vale, Mansfield, Notts. NG20  
9PF, UK  
E-mail : [Brian\\_Chambers@adas.co.uk](mailto:Brian_Chambers@adas.co.uk)

**R. J. Unwin**  
FRCA, MAFF, 17 Smith Square,  
London SW1 3JR, UK

## Abstract

*The heavy metal contents of a range of animal manures (farmyard manures, slurries and poultry manures) were measured to give an indication of 'typical' concentrations, along with the metal contents of livestock feeds (dairy and beef cattle, pigs and poultry) from the same sampled farms. Based on the 'typical' manure metal analyses, standard total nitrogen (N) and dry matter contents, pig manure applications supplying 250kg/ha of N were estimated to apply ca. 2.2 kg zinc - Zn/ha and 1.6 kg copper - Cu/ha, and poultry manure applications ca. 2.0 kg Zn/ha and ca. 0.4 kg Cu/ha. Cattle manure dressings were estimated to apply ca. 1.0 kg Zn/ha and 0.3 kg Cu/ha, largely representing the recycling of metals in cattle farming systems. 'Typical' manure metal concentrations were combined with farm census data on animal numbers and estimates of manure production quantities, to identify areas where heavy metals may be accumulating at elevated rates. Calculations of annual metal loadings to the agricultural land area in each 5 km<sup>2</sup> grid square (using GIS) indicated that the highest loadings of Zn (up to 3.3 kg/ha) and Cu (up to 2.2 kg/ha), corresponded with the main pig farming areas in East Anglia and Humberside. The highest estimated annual loadings of other metals were : nickel (up to 0.08 kg/ha), chromium (up to 0.064 kg/ha), cadmium (up to 0.007 kg/ha) and lead (up to 0.073 kg/ha).*

Keywords : heavy metals, animal manures, livestock feeds, GIS mapping

## Résumé

La teneur en métaux lourds de différents types de déjections (fumiers bovins, lisiers et fumiers de volailles) a été déterminée afin d'apprécier la concentration « typique » de ces produits ainsi que celle des aliments utilisés au sein des fermes échantillonnées. Sur la base de cette analyse « type » en métaux, sur une teneur

courante en azote et en matière sèche, il apparaît que les épandages de lisier apportant 250 kg N/ha s'accompagnent d'un apport de 2,2 kg zinc Zn/ha et de 1,6 kg cuivre Cu/ha, alors que les doses correspondantes pour les fumiers de volailles s'établissaient à 2,0 kg Zn/ha et 0,4 kg Cu/ha. Les épandages de fumier bovin s'accompagnent d'apports en métaux de l'ordre de 1,0 kg Zn/ha et 0,3 kg Cu/ha, ce qui représente largement un recyclage des métaux en système d'exploitation bovine.

Cette concentration « type » en métaux a été croisée avec les données statistiques sur les cheptels présents afin de déterminer les quantités de déjections produits et ainsi d'identifier les zones d'accumulation importante en métaux lourds. Ces calculs sur une base unitaire de 5,5 km<sup>2</sup> (utilisation d'un SIG) indiquent que les charges maximales en zinc (jusqu'à 3,3 kg/ha) et en cuivre (jusqu'à 2,2 kg/ha) correspondent aux zones d'élevage porcin développé à l'Est Anglia et Humberside. Les charges maximales pour les autres métaux étaient : nickel (jusqu'à 0,08 kg/ha), chrome (jusqu'à 0,064 kg/ha), cadmium (jusqu'à 0,07 kg/ha) et plomb (jusqu'à 0,073 kg/ha).

**Mots clés** : métaux lourds, déjections animales, alimentation animale, représentation SIG.

## 1. Introduction

In view of concerns about heavy metal impacts on soil fertility and the potential transfer of certain metals to human diets, there is a need to quantify heavy metal inputs to agricultural soils and to assess which soils are most vulnerable to pollution. To assess the impact of agricultural management practices on heavy metal concentrations of soils, heavy metal balances or budgets can be calculated. This approach requires information on the quantities of metals which are input to and lost from the agricultural systems under consideration.

The major inputs of metals to agricultural systems are:

atmospheric deposition	inorganic fertilisers
sewage sludge	animal manures
agrochemicals	industrial by product 'wastes'

Losses occur through offtake in crops or livestock products, leaching and via soil erosion. Previous research has considered in some detail metal inputs to soils via sewage sludge, inorganic fertilisers and agrochemicals (Alloway, 1995; Smith, 1996). However, there was little up-to-date information on heavy metal inputs via animal manures (cattle, poultry and pigs) in England and Wales, and no information on their geographical distribution.

In this study, farm census data on animal numbers (MAFF, 1996), best estimates of manure production (MAFF, 1994) and manure metal concentrations, and total topsoil heavy metal concentrations were combined in order to identify areas of England and Wales where heavy metal additions from animal manures may be occurring at elevated rates. To verify that the 'typical' manure metal concentration measurements were representative of pig and poultry manures, studies were initiated to enable manure metal concentrations to be predicted from a knowledge of feed metal analyses.

## **2. Methodology**

### **2.1 Heavy metal concentrations in livestock feeds and manures**

The heavy metal (Zn, Cu, Ni, Pb, Cr, Cd) contents of a range of animal manures (straw based farmyard manures, slurries and poultry manures) were measured on a number of sample farms to give an indication of 'typical' manure metal concentrations in England and Wales. The metal contents of livestock feeds (dairy and beef cattle, pigs and poultry) from the same sample farms were also measured. A total of 85 manure samples and 270 feed samples were analysed.

To verify that these 'typical' manure metal concentration measurements were representative of pig and poultry manures, further studies were initiated using a 'balance' approach, measuring all metal inputs and outputs in selected poultry (broiler) and pig (grower and finisher) farming systems.

### **2.2 Heavy metal loading from animal manures in England and Wales**

Farm census data on animal numbers (1995), best estimates of manure production and manure metal concentrations were combined in order to identify areas of England and Wales where heavy metal additions from livestock manures may be occurring at elevated rates. The data and calculations were input into a GIS mapping system in order to create heavy metal loading maps based on the agricultural land area in each 5km grid square.

## **3. Results and discussion**

### **3.1 Heavy metal concentrations in livestock feeds and manures**

The heavy metal content of animal manures is largely a reflection of metal concentrations in the feeds consumed and the efficiency of food dry matter conversion.

Manure type (no. of samples)	Dry matter (%)	Zn	Cu	Ni	Pb	Cr	As	Cd
Dairy FYM (6)	16	145	31.4	2.8	2.24	2.58	1.15	0.42
Beef FYM (12)	21	63	15.6	2.1	1.40	1.50	0.71	0.14
Pig FYM (7)	21	387	346	5.0	2.83	1.87	0.73	0.68
Dairy slurry (20)	7	176	51.0	5.5	4.79	5.13	1.09	0.20
Beef slurry (8)	13	132	30.9	3.3	5.80	2.62	0.98	0.22
Pig slurry (12)	3	403	364	7.8	<1.00	2.44	1.33	0.30
Broiler/turkey litter (12)	56	403	92.4	4.9	2.94	7.53	0.75	0.38
Layer manure (8)	37	423	65.6	6.1	9.77	4.79	0.45	1.03

*Table 1*  
*Median dry matter and heavy metal concentrations (mg/kg dry matter) in animal manures in England and Wales*

Heavy metal analysis of animal manure samples showed that pig manures typically had Zn concentrations of ca. 400 mg/kg dry matter (dm) and Cu concentrations of ca. 350 mg/kg dm, reflecting Zn and Cu additions to the pig diets (Table 1). The poultry manures had Zn concentrations of ca. 400 mg/kg dm and Cu concentrations of ca. 80 mg/kg dm, which was 2-5 times higher than concentrations in the poultry feeds, reflecting the efficiency of food dry matter conversion. Typical Zn concentrations in cattle manures were ca. 130 mg/kg dm and Cu concentrations ca. 30 mg/kg dm. Dairy cattle manures had higher concentrations of most metals than beef cattle manures, probably due to the mineral supplements fed to dairy cattle.

Results from the experimental metal balance studies showed that broiler litter Zn and Cu concentrations were similar to those found in the previous survey (Table 1) at ca. 400 mg/kg Zn and ca. 100 mg/kg Cu, respectively. Excreta metal concentration factor (CF) calculations showed that all metals, except Pb (CF ca. 1.5), were similar to the CF for dry matter at ca. 5, indicating that they were not preferentially retained by the birds. The study suggests that a CF of ca. 5 could be used to estimate most heavy metal concentrations in broiler excreta from a knowledge of feed heavy metal concentrations.

In the experimental grower and finisher pig balance studies, Zn and Cu concentrations in faeces and urine were measured separately and the data combined to provide overall excreta concentrations. Again, excreta metal CF calculations showed that all metals, except Pb (CF ca. 2), were similar to the dry matter CF at ca. 7, indicating that they were not preferentially retained by the pigs. The study suggests that a CF of ca.7 can be used to estimate most heavy metal concentrations in pig excreta from a knowledge of feed heavy metal concentrations.

### 3.2 Heavy metal loadings from animal manures in England and Wales

Animal manures are a valuable source of organic matter and major plant nutrients, however care must be taken to ensure that heavy metal applications in animal manures do not result in unnecessary levels of soil heavy metal accumulation.

The survey slurry metal analyses (Table 1) were adjusted to more 'typical' manure dry matter contents for undiluted slurry (ca. 10%), using the survey-derived relationships between slurry dry matter content and fresh weight manure metal concentrations (eg. Figure 1). Metal concentrations in solid manures were recalculated based on typical rates of straw (FYM) or woodchip (broiler/turkey litter) additions to excreta (MAFF, 1994). Using the adjusted manure metal concentrations and total nitrogen (N) contents at 'typical' dry matter contents (MAFF, 1994), metal loading rates from manure applications at 250 kg/ha total N were estimated (Table 2).

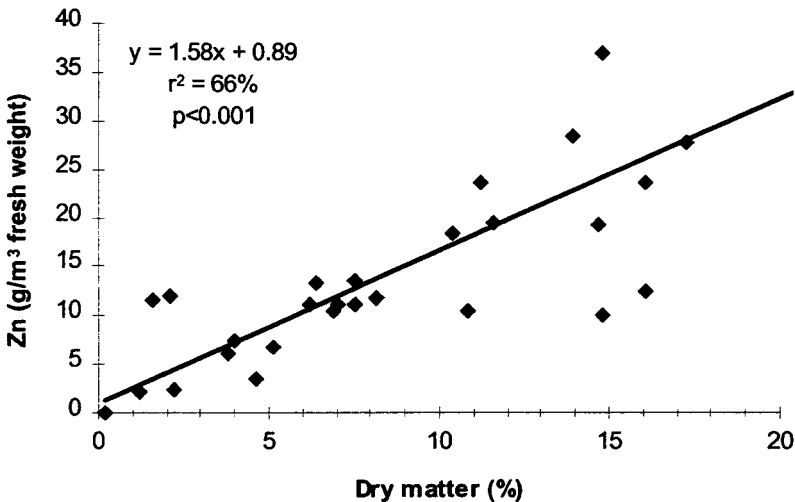

*Figure 1*  
*Relationship between dry matter content and fresh weight Zn concentrations for cattle slurry*



Manure type (dry matter content)	Total N (kg/t or m <sup>3</sup> ) <sup>1</sup>	Zn	Cu	Ni	Pb	Cr	As	Cd
Cattle FYM (25 %)	6.0	0.7	0.2	0.03	0.03	0.02	0.01	<0.01
Pig FYM (25 %)	7.0	2.1	1.5	0.05	0.03	0.02	0.01	<0.01
Dairy slurry (10%)	4.5	0.9	0.3	0.03	0.04	0.03	0.01	<0.01
Beef slurry (10%)	3.5	1.2	0.3	0.04	0.05	0.04	0.02	<0.01
Pig slurry (10%)	7.0	2.3	1.7	0.05	0.03	0.02	0.01	<0.01
Broiler/turkey litter (60%)	29	1.1	0.2	0.02	0.02	0.01	<0.01	<0.01
Layer manure (30%)	15	2.9	0.5	0.05	0.05	0.03	<0.01	0.01

<sup>1</sup>Typical total N content of manure (MAFF, 1994)

*Table 2*  
*Estimated 'typical' heavy metal loading rates (kg/ha)*  
*from animal manures applied at 250 kg/ha total N.*

Pig manure applications at these rates were estimated to apply ca. 2.2 kg/ha Zn and ca. 1.6 kg/ha Cu. Poultry manures were estimated to apply 1.1-2.9 kg/ha Zn and 0.2-0.5 kg/ha Cu when spread at this rate. Cattle manure dressings applied ca. 1.0 kg/ha Zn and ca. 0.3 kg/ha Cu, largely representing the recycling of metals in the cattle farming system.

Calculations of annual metal loadings from animal manure additions indicated that the highest loadings of Zn (up to 3.3 kg/ha) and Cu (up to 2.2 kg/ha) to the agricultural land area in the 5 km<sup>2</sup> grid square, largely corresponded with the main pig farming areas in East Anglia and Humberside (Figures 2 and 3). The highest estimated annual loadings of other metals were : nickel (up to 0.08 kg/ha), chromium (up to 0.064 kg/ha), cadmium (up to 0.007 kg/ha) and lead (up to 0.073 kg/ha).

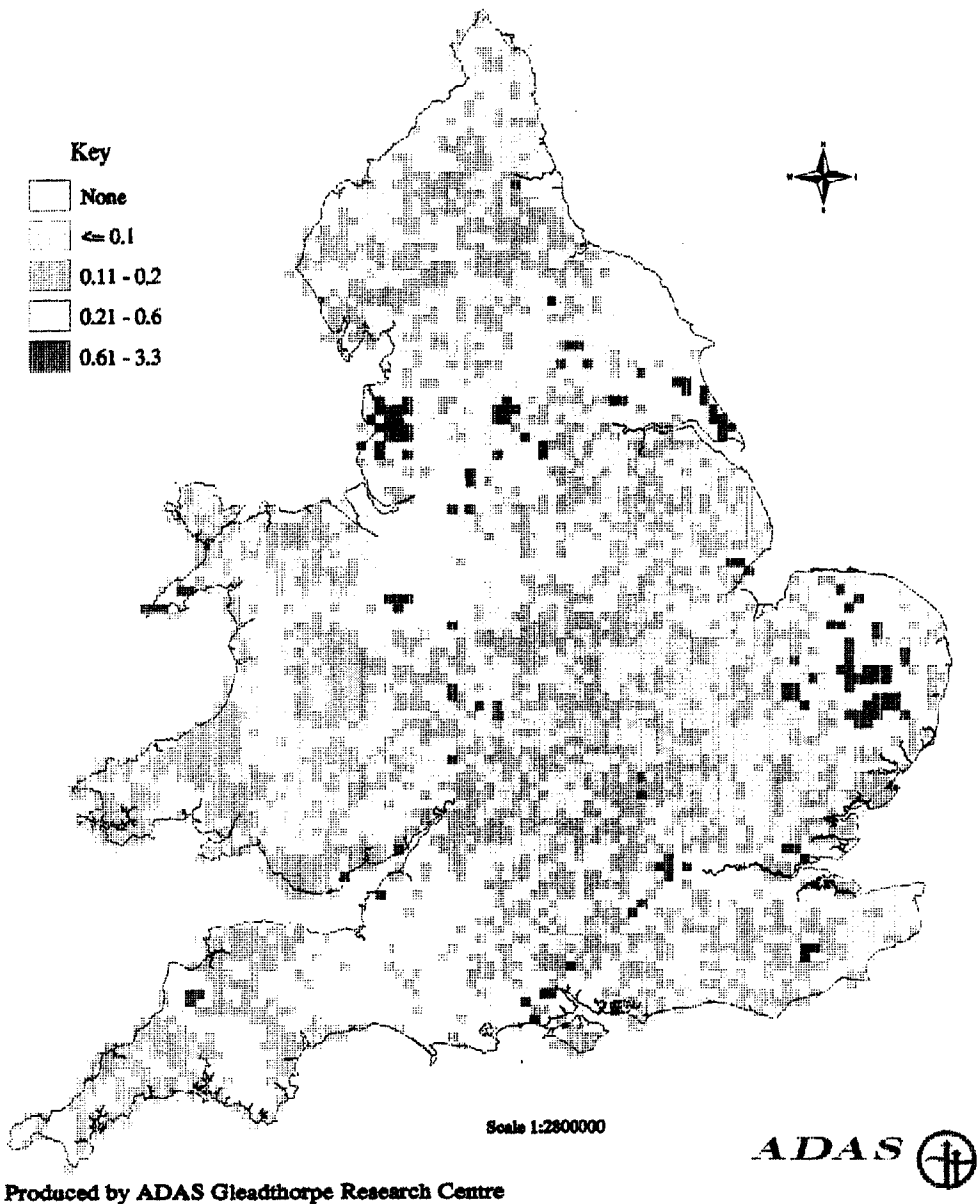

*Figure 2*  
 Total annual loading of zinc (kg/ha) from livestock manures  
 on agricultural land in England & Wales.

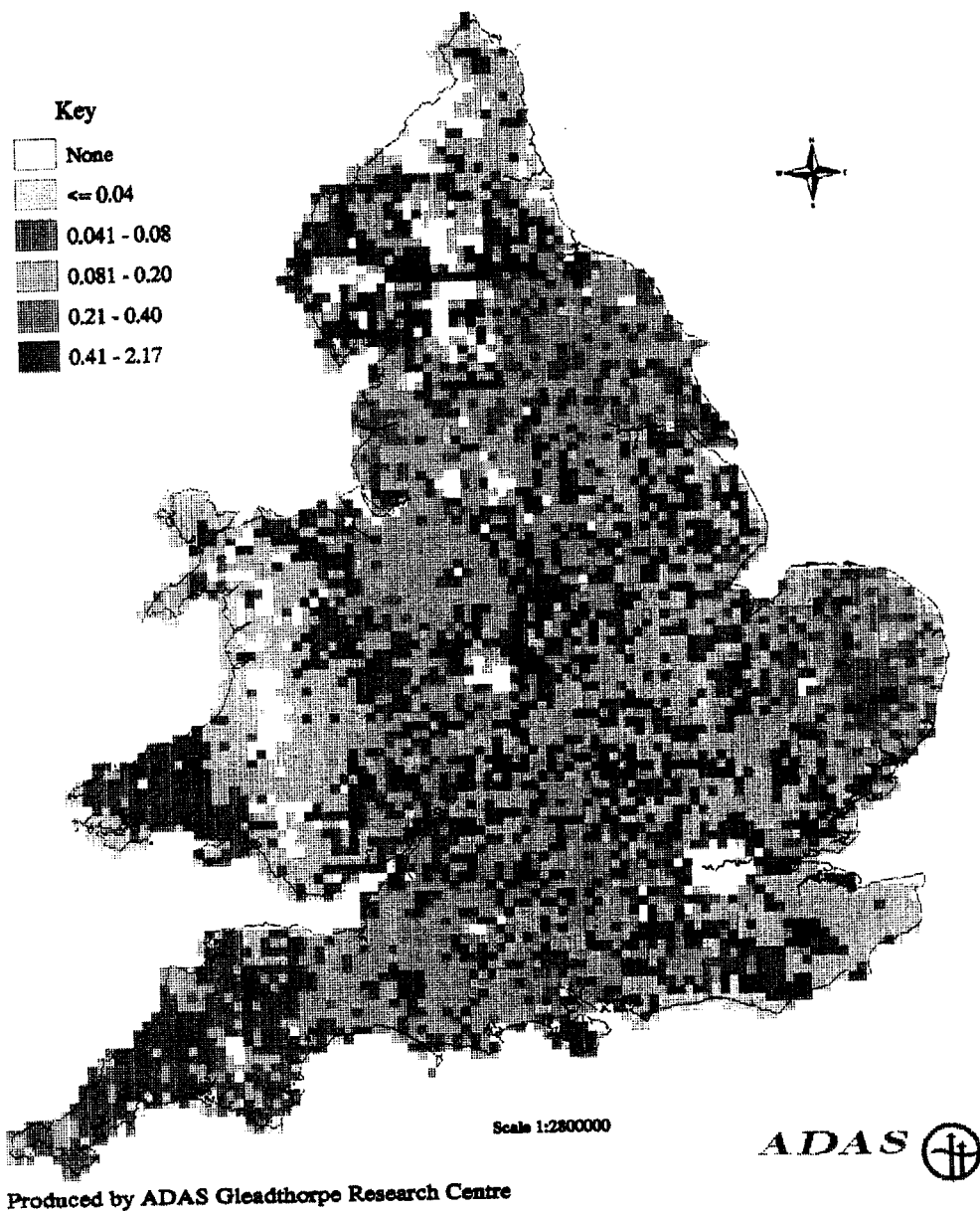

*Figure 3*  
 Total annual loading of copper (kg/ha) from livestock manures  
 on agricultural land in England & Wales.

## 4. Summary and conclusions

A survey of 85 animal manure samples in England and Wales found that the highest concentrations of Zn and Cu were in pig and poultry manures, largely reflecting metal inputs in the feeds. Metal balance studies have shown that it is possible to estimate heavy metal concentrations in poultry and pig excreta from a knowledge of the feed heavy metal contents.

The highest estimated loadings of Zn, Cu, Ni, Cd, Cr and Pb to agricultural soils in the England and Wales were from pig manures. As the pig industry is concentrated in two main areas in England and Wales (East Anglia and Humberside), these are the areas where soil metal accumulation (particularly Zn and Cu) is likely to be occurring at the greatest rates.

## 5. Acknowledgments

Funding of this work by the UK Ministry of Agriculture, Fisheries and Food (MAFF) is gratefully acknowledged.

## 6. References

**ALLOWAY B.J.** (1995). *Heavy Metals in Soils*. 2nd Edition. Blackie, Glasgow.

**MAFF** (1994). *Fertiliser Recommendations for Agricultural and Horticultural Crops, Reference Book 209*. HMSO, London.

**MAFF** (1996). *The Digest of Agricultural Census Statistics, United Kingdom 1995*. HMSO, London.

**SMITH S. R.** (1996). *Agricultural Recycling of Sewage Sludge and the Environment*. CAB International.

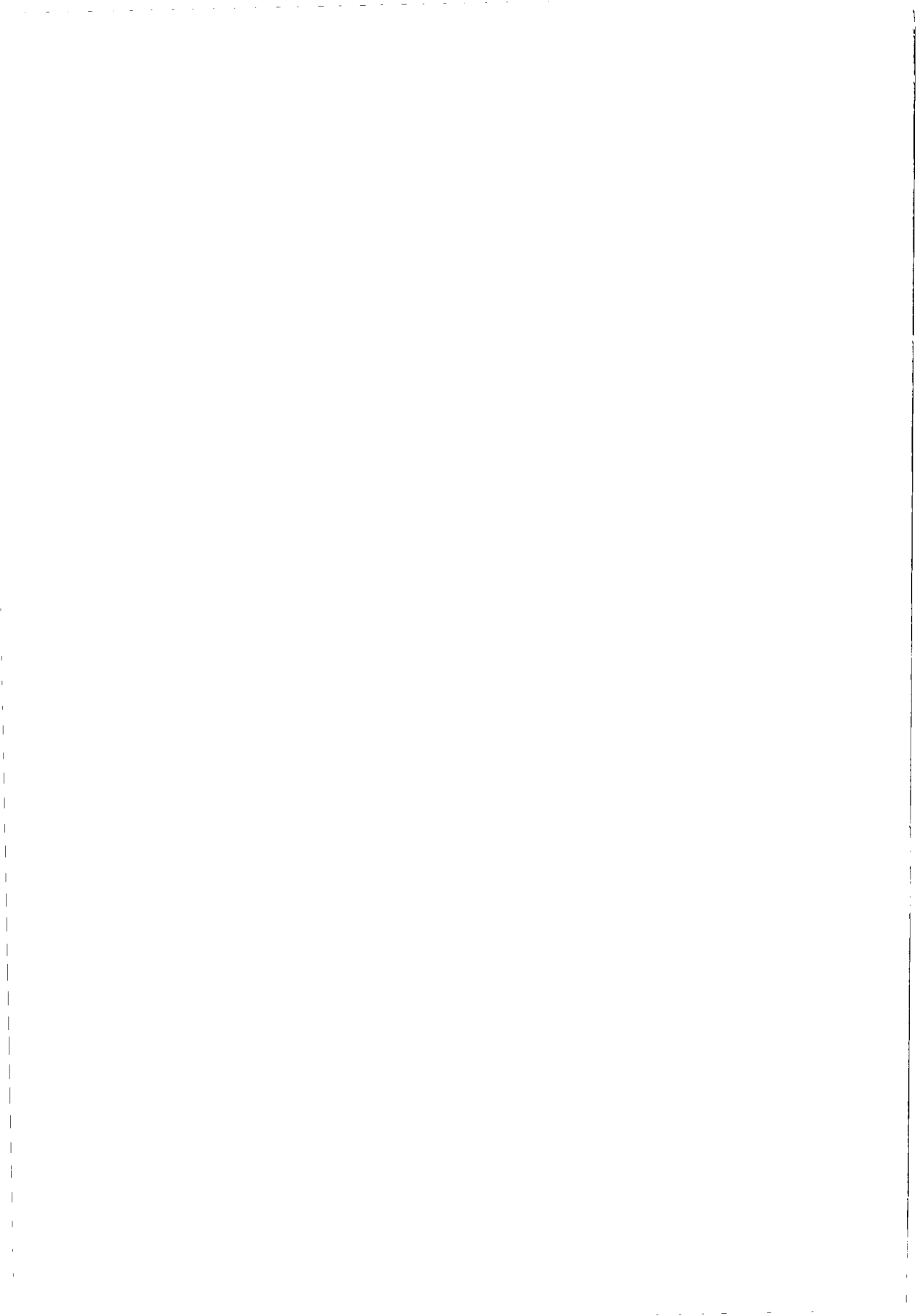

## **Copper soil retention capacity after intensive and repeated pig slurry applications**

*Capacité de rétention du cuivre dans un sol soumis à des épandages  
intensifs et répétés de lisier de porc.*

<b>Loïc L'HERROUX<sup>1</sup>, Sophie M. LE ROUX</b>	<b>José MARTINEZ</b>
Université de Bretagne Occidentale.	Cemagref. Unité de Recherche
Département de Chimie. UMR 6521.	Gestion des effluents d'élevage et des
UFR Sciences et Techniques.	déchets municipaux.
6, avenue Le Gorgeu.	17, avenue de Cucillé.
29285 Brest Cedex. France	35044 Rennes Cedex. France

### **Abstract**

*The high metal contents of pig slurry spread on agricultural fields can bring large amounts of metals to the environment. This work is part of a large study aimed to determine the impact of land pig slurry applications on soil and water quality, with emphasis to metal distribution and speciation within such systems, and to soil retention capacity. This paper presents the main results of field and laboratory investigations about copper accumulation in a soil after high loads of pig slurry spreading.*

*Samples were regularly collected on an experimental specially equipped field so-called "Solepur". On this field, numerous pig slurry applications were performed from 1991 to 1995, approximately corresponding to the amount which might have been spread over one century. The "Solepur" process can be considered as a simulation model for what happens to metals in pig slurry under normal field conditions over a long period of time.*

*Total concentrations and speciation data of copper were measured during five years within four compartments: pig slurry, soil, drainage water and plants. It was then possible to calculate metal fluxes and budgets.*

*The results showed accumulation of copper in bioavailable form in the soil surface layer, in the same form than in pig slurry, i.e. mainly "bound to organic matter", and very little downward metal movement was observed. Copper concentrations in drainage water were low and confirmed metal retention in the soil.*

---

<sup>1</sup> Present address : Department of Agriculture for Northern Ireland. Agricultural and Environmental Science Division. Newforge Lane, BT9 5PX. Belfast. UK. E-mail : lherroux@alpha1.dani.gou.uk

*Laboratory experiments carried out on copper soil retention capacity showed an enhanced adsorption of copper in the soil after high pig slurry applications. This result supports the idea that saturation of soil by copper from pig slurry is unlikely.*

## **Résumé**

Les teneurs élevées en éléments métalliques contenus dans les lisiers épandus en agriculture peuvent entraîner des apports conséquents à l'environnement. Le but de ce travail est de déterminer le devenir de ces métaux issus des épandages de lisiers et de préciser les éventuels risques de pollutions des sols et des eaux par ces éléments en abordant l'aspect de la spéciation métallique et de la capacité de filtration du sol. Cet article présente les principaux résultats d'un travail au champ et en laboratoire sur l'accumulation de cuivre dans un sol soumis à des doses importantes apportées par les épandages de lisier de porc.

Les échantillons ont été prélevés régulièrement sur un dispositif expérimental appelé SOLEPUR. Sur cette parcelle, de nombreux épandages de lisiers de porcs ont été effectués entre 1991 et 1995, correspondant globalement à ce qui serait épandu en 100 ans.

Les concentrations totales en cuivre ainsi que la spéciation ont été mesurées sur 4 compartiments : lisier de porc, sol, eau de drainage et les végétaux.

Les résultats montrent que l'accumulation du cuivre dans le sol s'effectue sous une forme biodisponible et dans une fraction liée à la matière organique. Il n'est pas observé de migration du cuivre en profondeur. Les concentrations en cuivre dans les eaux de drainage étaient très faibles, ce qui confirme la rétention de cet élément par le sol.

Un essai en laboratoire sur l'évaluation de la capacité de rétention du sol en cuivre montre une capacité supérieure dans le sol soumis à des épandages intenses.

## **1. Introduction**

Intensive pig farming practices engender large volumes of pig slurry with no other solution for farmers than land disposal. This common practice results in serious environmental problems such as nitrate and phosphate contamination in ground waters and rivers.

Another issue less studied is metal pollution: pig slurry actually contains high concentrations of metals such as Cu, Zn, Fe, Mn, Co, Cd (Meeus-Verdinne *et al.*, 1986) and in Brittany a long-term study performed by Coppenet *et al.* (1993) concluded in a regular increase of copper and zinc concentrations in soils.

The present work is a five-year study about copper brought by heavy and repeated pig slurry applications onto agricultural lands (L'Herroux *et al.*, 1997). For this purpose, an experimental field was set up by the Cemagref<sup>1</sup> of Rennes (Martinez, 1997) and pig slurry was regularly spread on it for 5 years. Drainage water was daily sampled, making possible an assessment of metal fluxes. This experimental procedure appeared as a good model for simulating what happens to metals in pig slurry under normal field conditions over a long period of time.

Metal speciation is known to be more appropriate than total concentrations to assess metal impact on the environment since each fraction of the speciation can provide information on metal mobility and bioavailability. Sequential extractions in soil and slurry were performed according to the procedure described by Tessier *et al.* (1979) for the partitioning trace metals into five fractions likely to be affected by changes in environmental conditions.

Laboratory experiments conducted on soil samples in 1995, after 4 years of pig slurry spreadings, showed the adsorption capacity of the soil in function of pH and depth. Surface sorption can regulate the solubility of metals in the soil solution and influence the uptake of metals by plants.

## 2. Materials and methods

The Solepur treatment unit, detailed in a previous paper (Martinez, 1997), was set up in 1990 in North-Finistère (Brittany) by the Cemagref of Rennes. It consisted of a 3280-m<sup>2</sup> field hydrologically-isolated from the surrounding soil at a depth of 80 cm and equipped to recover all the leachate. Drainage water flowed under gravity and passed through a field laboratory fitted with an on-line flowmeter and an Isco autosampler to collect daily water samples. Repeated high pig slurry applications were performed on the experimental field from 1991 to 1996 at a mean rate of 1000 m<sup>3</sup> ha<sup>-1</sup> yr<sup>-1</sup>, representing 4571 m<sup>3</sup> ha<sup>-1</sup> of slurry over the 5-year experiment. Another smaller field similarly set up and equipped did not receive any spreading and was used as a control plot. *Lolium perenne* was cultivated on both fields and cut down twice a year.

### Sampling

*Soil* : Soil samples were annually collected in March at three depths (per layer: 0-20, 20-40 and 40-60 cm depth) and stored in polyethylene vials at room temperature.

*Pig slurry*: During each slurry application representative slurry samples were collected, stored in polyethylene vials and frozen.



*Drainage water.* One litre of drainage water was daily collected in 250-mL fractions every 6 hours. The water samples were transferred into 125-mL polyethylene bottles, acidified with concentrated HCl to reach a pH of 2 and stored until analysis.

### Total copper

To determine the total copper concentrations in slurry and soil, the samples were digested by a mixture of strong acids (65% HNO<sub>3</sub>, 30% H<sub>2</sub>O<sub>2</sub> and 48% HF).

### Speciation

*Soil and pig slurry* The speciation protocol described by Tessier *et al.* (1979) is based on successive leachings of the samples by different reagents. This procedure enables to split metals into five fractions likely to be affected by changes in environmental conditions (Table 1).

	Metal fractions	Processes responsible for metal release
	(I) "Exchangeable".	Weak complexes, ion exchange
	(II) "Bound to Carbonates".	pH decrease (pH = 5)
Soil	(III) "Bound to Fe or Mn Oxides"	Reduction of metal oxides
	(IV) "Bound to Organic Matter"	Degradation of organic matter
	(V) "Residual".	No possible release, metals hold in mineral structures

*Table 1*  
*Informations obtained from the metal speciation procedure*  
*(Tessier et al. 1979).*

### Copper adsorption experiments

This experiment was conducted to compare copper soil sorption between the two fields (experimental and control) and determine whether copper soil "saturation" can occur. Soil samples used for the experiment were collected from the experimental field in 1995, after 4 years of pig slurry spreading, at 3 depths (0-20 cm ; 20-40 cm and 40-60 cm) and at the surface of the control field (0-20 cm). 100-mL solutions of copper chloride ranging from 0 to 1000 mg L<sup>-1</sup> were added to a 20-g soil sample to determine copper adsorption. The pH was adjusted to 6.0 to reach the initial pH of the surface soil before the beginning of the experiment in 1991. The mixture was shaken at room temperature for 24 hours. Previous experiments showed that equilibrium was reached within this time. The samples were centrifuged, filtered through 0.45 µm membranes and stored in 20-mL Teflon vials.

## Analysis

Copper concentrations in solution were determined using either flame or flameless absorption spectrophotometry, according to the sample concentration; a standard addition technique was used to account for possible matrix effects.

## 3. Results

### Pig slurry :

The mean copper concentration in fresh pig slurry over the 5 years of spreadings was  $40 \text{ mg Cu.kg}^{-1}$  (SD=15, n=43). This concentration is in agreement with values reported by other authors (Meeus-Verdine *et al.*, 1986; Bernal *et al.*, 1992). The amount of pig slurry spread on the experimental field after the five years of the experiment was equivalent to  $4571 \text{ m}^3 \text{ ha}^{-1}$ . It resulted in a copper supply of two hundred kilograms.

Results of copper speciation in pig slurry indicated a large percentage of metal in the "Organic" fraction (66%) and in the "Oxides" fraction (28%) The low percentage observed in residual form (<1%) indicated that copper brought by pig slurry was in bioavailable forms.

### Soil :

Copper clearly accumulated in the soil surface layer ( $38 \pm 8 \text{ mg Cu.kg}^{-1}$ ) and slightly in the middle layer ( $20 \pm 5 \text{ mg Cu.kg}^{-1}$ ) (Figure 1). No significant change occurred in total copper concentration for the deepest layer (40-60 cm), indicating no downward metal movement.

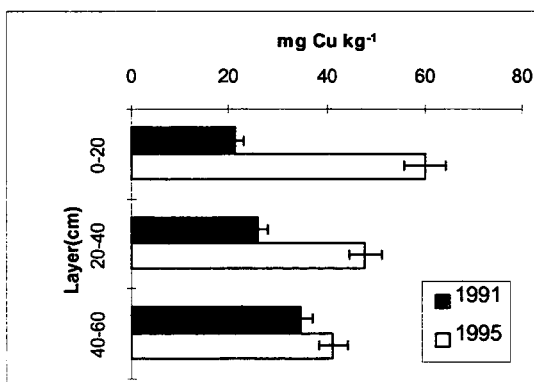

Figure 1.

Total copper concentrations in the soil at the three depths in 1991 and 1995. Error bars indicate standard deviation (n = 4).

Soil speciation in the surface layer showed that copper at the beginning of the experiment (1991) was mainly in the "Residual" fraction. After 4 years of spreadings metal concentrations increased in the "Organic" fraction, and slightly in the "Oxides" fraction (Figure 2).

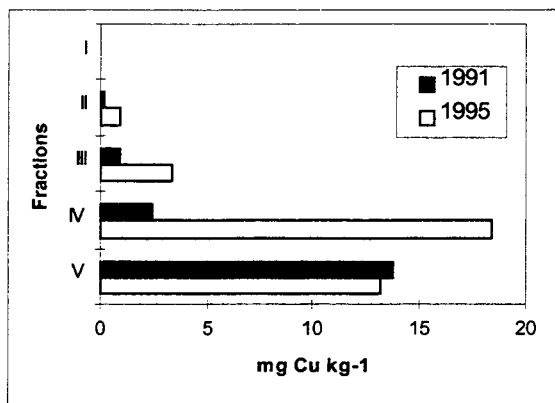

Figure 2.

Speciation of copper in the soil surface layer (0-20 cm) in 1991 and 1995.

#### Drainage water :

Copper total concentrations in drainage water from the experimental field were low, below  $5.0 \mu\text{g L}^{-1}$  (average of  $3.4 \pm 0.9 \mu\text{g Cu L}^{-1}$ ,  $n=178$ ), for the drainage season 1995/96. These concentrations were higher than the water from the control field (average of  $0.7 \pm 0.2 \mu\text{g Cu L}^{-1}$ ).

The total amount of copper leaving the field by lixiviation over the five-year experiment, from 1991 to 1995, was  $0.04 \pm 0.01 \text{ kg ha}^{-1}$ .

#### Grass :

Slurry inputs to the soil did not increase copper concentrations in the grass (*Lolium perenne*) in spite of slightly higher concentrations in the herbage from the experimental field than those from the control plot with concentrations, expressed in mg Cu per kg of dry matter, of respectively  $14.7 \pm 9.7$  ( $n = 8$ ) and  $2.3 \pm 2.2$  ( $n = 2$ ).

#### Adsorption of copper by the soil (pH=6.0) :

The soil surface of the experimental field adsorbed much more copper than the other layers. For an equilibrium concentration of  $100 \text{ mg L}^{-1}$ , copper adsorption was more than  $3000 \text{ mg Cu kg}^{-1}$  for the surface soil layer and respectively 450 and  $140 \text{ mg Cu kg}^{-1}$  for the intermediate (20-40 cm) and deepest (40-60 cm) layers. The adsorption by the surface layer of the control field was only  $110 \text{ mg Cu kg}^{-1}$ .

Adsorption curve of the soil surface of the control field was similar to that of the deepest layer (40-60 cm) of the experimental field.

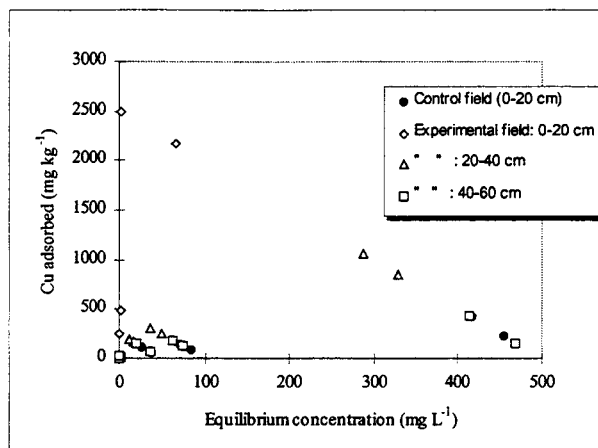

Figure 3.

Adsorption of copper at pH=6.0 for different soils in 1995 (0-20 cm, 20-40 cm, 40-60 cm of the experimental field and 0-20 cm of the control field).

#### 4. Discussion

Copper brought by pig slurry appeared to be mainly in bioavailable forms, forms likely to release metal into soil solution. But the copper concentrations in drainage water remained quite low, showing a retention of metal by the soil, particularly in the upper layer. The regular ploughing of the field to a depth of 30 cm was probably responsible for the copper concentrations increase as far as 40 cm.

Metal fractions in soil were in accordance with the slurry speciation: copper input from pig slurry in the "Organic" fraction was assessed around  $92 \pm 19 \text{ kg ha}^{-1}$ , and in the same fraction of the soil speciation the input was estimated at  $90 \text{ kg ha}^{-1}$ . Copper bound to organic matter in slurry was probably "non reactive" or, as an alternative hypothesis, copper introduced by slurry additions forms strong organic complexes with organic components in the soil, mainly humic substances (Williams *et al.*, 1987; Hesterberg *et al.*, 1993). The quantity of copper brought to the field in the "Organic" fraction and the quantity of metal found in the same fraction in the soil were very close. This result reinforced the idea that copper stays in the soil bound to the organic matter of the pig slurry.

Thus the intensive slurry spreadings increased the copper retention ability of the surface soil. This retention ability decreased with depth showing that copper complexing agents stayed in the soil surface and no downward movement occurred. This conclusion does not contradict the idea that modifications of organic matter occur in this field, but these changes are too slight or the organic molecules that are formed have too low complexation properties to release a large part of copper into solution and make it bioavailable.

## 5. Conclusion

The high metal concentrations contained in pig slurry can introduce large amount of copper and other metals in agricultural fields where spreading is a common practice.

Copper was found in bioavailable forms in pig slurry, hence a possible effect on plants (phytotoxicity) can be anticipated. This study showed that metal from pig slurry stayed mainly in the same fraction in soil, and no downward metal movement was observed.

An important result of this study is the increase of the soil copper retention ability after intensive pig slurry spreadings. This result supports the idea that saturation of soil by copper from pig slurry is unlikely. Copper stays in the soil, associated with the organic matter brought by pig slurry.

The metal was found in the soil in bioavailable form, so further studies are necessary to find under which conditions copper could be released in the soil solution and become toxic for the crops, or could be lixiviated from the field and increase metal concentration in ground water. Actually some modifications of natural conditions, such as changes of pH, Eh or soil composition, are expected over a long time scale and a good understanding of all of these processes is necessary for predicting the fate of metals. For example waterlogging can induce reducing conditions and lead to degradation of organic matter.

## 6. References

**BERNAL M. P., ROIG A., LAX A. & NAVARRO A. F.** (1992) Effects of the Application of Pig Slurry on Some Physico-Chemical and Physical Properties of Calcareous Soils. *Bioresource Techn.*, 42 : 233-239

**COPPENET M., GOLVEN J., SIMON J.C., LE CORRE L. & LE ROY M.**(1993) Evolution chimique des sols en exploitations d'élevage intensif: exemple du Finistère. *Agronomie*. 13. 77-83.

**HESTERBERG D., BRIL J. & DEL CASTILHO P.**, 1993. Thermodynamic modeling of Zinc, Cadmium, and Copper solubilities in a manured, acidic loamy-sand topsoil. *J. Environ. Qual.* 22. 681-688.

**L'HERROUX L., LE ROUX S., APPRIOU P. & MARTINEZ J.**, 1997. Behaviour of metals following intensive pig slurry applications to a natural field treatment process in Brittany (France). *Environ. Pollut.* 97. 119-130.

**MARTINEZ J.**, 1997. Solepur: A soil treatment process for pig slurry with subsequent denitrification of drainage water. *J. Agric. Engng. Res.* 66. 51-62.

**MEEUS-VERDINNE K., SCOKART P.O. & DE BORGER R.**, 1986. Evaluation des risques pour l'environnement provenant des métaux lourds contenus dans les déchets animaux. *Rev. Agric.* 4. 801-817.

**TESSIER A., CAMPBELL P.G.C. & BISSON M.**, 1979. Sequential extraction procedure for the speciation of particulate trace metals. *Anal. Chem.* 51. 844-851.

**WILLIAMS D.E., VLAMIS J., PUKITE A.H. & COREY J.E.**, 1987. Metal movement in sludge-amended soils: a nine year study. *Soil Sci.* 143. 124-131.



## Heavy metal content of manures in Switzerland

*Teneurs en métaux lourds dans les déjections animales en Suisse.*

**Harald MENZI**

Institute for Environmental Protection and  
Agriculture Liebefeld (FAL-IUL)  
CH-3003 Berne, Switzerland.  
E-mail : Harald.Menzi@IUL.admin.ch

**Jürg KESSLER**

Swiss Federal Research Station for  
Animal Production (RAP)  
CH-1725 Posieux, Switzerland

### Abstract

*Manures contribute considerably to heavy metal loads on agricultural soils. To assess the importance of heavy metals in manures, we analyzed the content of copper (Cu), zinc (Zn), cadmium (Cd) and lead (Pb) in about 1100 manure samples. Special attention was given to manures from pigs and beef cattle (600 and 250 samples respectively; balance experiments on different farms). The range of heavy metal contents was large for all animal categories, manure types and elements. Differences could mostly be explained by the content of the rations. On a dry matter basis, the Cu and Zn content was higher for pig manures than for cattle and poultry manures. These differences almost disappeared when calculated per unit phosphorus. The Cd and Pb content was higher in cattle manures than in pig and poultry manures due to the grass based rations. The mean (median) content of Cu and Zn in pig manures and the Cd and Pb content in cattle, pig and poultry manure have decreased considerably between 1990 and 1995 (Cu 28 %, Zn 17 %, Cd 56 %, Pb 49 %). This demonstrates the effect of air protection measures (Cd and Pb) and of recommendations to limit heavy metals in animal feed according to animal needs. At average animal density and mean heavy metal contents, heavy metal inputs from manures clearly exceed plant uptake only for Zn in pig and poultry production. At maximum heavy metal contents, inputs from manure can even exceed maximum heavy metal loads allowed for sewage sludge use in agriculture.*

Key words : manure, slurry, heavy metals, environment, feeding, pigs

### Résumé

Les déjections animales contribuent considérablement à la charge en métaux lourds apportés aux sols. Afin de vérifier l'importance des teneurs en métaux lourds, nous avons analysé la teneur en cuivre (Cu), zinc (Zn), cadmium (Cd) et plomb (Pb) dans environ 1100 échantillons d'effluents d'élevage. Une attention particulière a été portée aux déjections porcines et bovines viande (600 et 250 échantillons respectivement).



La teneur en métaux lourds varie considérablement pour toutes les catégories d'animaux, types de déjections. Les différences s'expliquent notamment par le contenu de l'alimentation. Sur une base de matière sèche, la teneur en cuivre et zinc est supérieure pour les lisiers et fumiers de porcs que pour les bovins et déjections avicoles. La teneur en cadmium et plomb était supérieure pour les déjections bovines que pour les porcs et volailles à cause de l'alimentation à base d'herbe/fourrage.

Les concentrations moyennes (médianes) en Cu et Zn dans les déjections porcines et en Cd, et Pb dans les déjections bovines, porcines et avicoles, ont diminué considérablement entre 1990 et 1995. Cela démontre l'effet des mesures de protection de l'air (pour Pb et Cd) et des préconisations pour adapter les métaux lourds dans l'aliment en fonction des besoins des animaux. En prenant en compte les densités moyennes animales et la moyenne en métaux lourds, les apports de métaux par les déjections excèdent les exportations par les plantes seulement pour Zn en production porcine et avicole.

Aux doses maximales rencontrées, les apports en métaux lourds par les déjections dépassent les charges en métaux autorisées pour l'épandage de boues de stations d'épuration en agriculture.

Mots-clés : déjections, lisier, métaux lourds, environnement, alimentation, porcs.

## 1. Introduction

Fertilizers, pesticides and deposition from the atmosphere introduce heavy metals to agricultural land. If the input surpasses plant uptake these heavy metals will accumulate in the soil. There is a growing awareness, that the heavy metal content of the soil is increasing at many locations and that critical levels could be reached on some surfaces within the foreseeable future if inputs are not reduced (e.g. Keller and Desales, 1997). Heavy metal loads on agricultural surfaces in Switzerland were studied for example by Buwal (1993), von Steiger and Baccini (1990), von Steiger and Obrist (1993), Frei et al. (1993) or Studer et al. (1995). Apart from some measurements on a small number of farms, these calculations used available databases to estimate the heavy metal input by agricultural management. Whilst quite detailed knowledge is available of the heavy metal content of mineral fertilizers (Buwal, 1991) and sewage sludge (Candinas et al., 1991), the data on manure is rather scarce. A first survey showed that heavy metal contents vary considerably between manure types, animal categories and farms (Menzi et al., 1993). This study also suggested, that the highest loads could be expected on pig farms. To get more reliable information about this variability and its causes, a more detailed study of the heavy metal content of different types of manure was organized which included a number of samples from other experiments as well as detailed balance experiments on pig and beef cattle farms.

## 2. Material and methods

Between 1991 and 1997 a total of about 1100 slurry and solid manure samples from cattle, pig and poultry production were analyzed for their content of copper (Cu), zinc (Zn), cadmium (Cd) and lead (Pb; table 1). Other metals could only be analyzed since 1996 and will therefore not be presented here. The content of dry matter (DM), total nitrogen (N), ammonium nitrogen ( $N_{NH_4}$ ), phosphorous (P), potassium (K), magnesium (Mg) and calcium (Ca) were also analyzed in all samples.

Animal category	Manure type	Cu + Zn	Cd + Pb
dairy cattle	liquid manure (all excrements)	48	48
	slurry (urine, some dung)	90	67
	solid manure stacked (dung, some urine, straw)	94	82
beef cattle	liquid manure	200	197
	farmyard manure (all excrements, straw)	54	53
fattening pigs	pig slurry	194	198
dry sows	pig slurry	81	75
sows with piglets/weaners	pig slurry	198	189
pigs undefined	pig slurry	47	26
	solid manure	41	42
laying hens	litter from belts	10	10
	litter deep pits	43	36
broilers, turkeys	litter	59	56
Total		1159	1079

Table 1

*Number of samples of different manure types which were analyzed for their content of copper (Cu), zinc (Zn), cadmium (Cd) and lead (Pb) from 1992 till 1997.*

For dairy cattle and poultry the samples were mostly taken from other projects working under farm conditions. These observations usually consisted of one to three replicate samples. For pigs most samples came from detailed balance experiments on 13 farms with fatteners and 11 farms with breeding sows. For breeding sows the following two groups were distinguished: "dry sows" and "sows with piglets/weaners". Weaners could not be distinguished as a special group because many farms remove the sow after weaning and leave the weaners in the same compartment. The balance experiments usually consisted of two to four periods of one to several weeks, depending on conditions and technical possibilities on the farms. Three to eight replicate samples were taken per observation period from different locations in the slurry channel, the slurry pit or of the deep litter solid manure at the time of removal. The quantity of slurry or solid manure produced during the experiment period was also determined. At least three times per farm the mineral and heavy metal content of

the ration and of individual feed components were analyzed and the feed consumption measured. Thus, the measured excretion could be compared to the one calculated from feed uptake and retention in animals. Similar balance experiments were done on 12 beef fattening farms.

Special attention was given to a good homogenization of the slurry and to the taking of representative manure samples. Preliminary balance experiments had shown that especially pig slurry samples taken with a scoop tended to have a lower content of elements excreted primarily in the feces (e.g. P content up to 40 % too low) than expected according to the balance calculations. A special probe which takes a sample over the whole depth of the slurry was therefore usually used and samples were taken with running homogenization equipment wherever possible.

Except for poultry, where the number of samples was relatively low, the number of samples analyzed and the selection of farms from which the samples originated can be considered to be quite representative for Swiss production.

After drying at 105 °C, 2.5 g of each sample were pulverized and ashed at 500 °C. The ash was extracted with 80 ml concentrated hydrochloric acid and diluted to 200 ml with water (final dilution 1:80). For the analysis this solution was further diluted by 1:10. The mineral content was analyzed by ICP-AES; Cu, Zn (until 1993), Cd and Pb (until 1995) by AAS. Starting in 1994 Cu and Zn were also analyzed by ICP-AES and starting in 1996 all other heavy metals could be analyzed by ICP-MS. Comparative analyses of selected samples showed that these changes in method did not have a statistically significant effect on the results. We used the average contents of replicate samples for further calculations on specific farms and median values for the mean concentrations of different farms. Heavy metal contents are presented relative to the DM or P content of the manure to facilitate the interpretation of the results in spite of the inevitable variability of the dilution of the slurries and the different DM content of slurry and solid manure.

To estimate the total heavy metal load in Swiss manure we multiplied the metal content per unit P of cattle liquid manure (dairy and beef cattle), pig slurry and poultry manure (belt litter hens, broiler litter) with the quantity of P excreted by the corresponding livestock category. This was calculated from animal census data and standard P excretion per animal (Walther et al., 1994). For horses, sheep and goats the metal content of cattle manure was used. The thus calculated heavy metal load does not include the quantity introduced by straw and other litter material.

### 3. Results and discussion

#### 3.1. Heavy metal content of manure per unit dry matter

On a dry matter basis, Cu- and Zn-contents were clearly higher for pigs (especially those of fattening pigs and of sows with piglets/weaners) than for other animals (table 2). This can be explained by the Cu and Zn added to pig feed for their antimicrobial and growth stimulating effect (Kessler et al., 1994). A high Cu content in the slurry was often linked with a high Zn content. As expected, the balance experiments clearly demonstrated a close dependence between the heavy metal content of the ration and the manure produced. As Cu and Zn are mainly used for weaners, the highest values were measured for this animal category (where it could be analyzed separately from the sows), followed by sows with piglets/weaners and fattening pigs (figure 1).

Animal category	Manure type	Cu	Zn	Cd	Pb	Cu	Zn	Cd	Pb
		$\mu\text{g g}^{-1}$ DM				$\text{mg g}^{-1}$ P			
dairy cattle	liquid manure	37.1	162.2	0.178	3.77	4.1	17.6	0.019	0.40
	slurry	19.1	123.3	0.160	2.92	2.7	16.6	0.022	0.42
	solid manure	23.9	117.7	0.172	3.77	3.2	16.1	0.025	0.49
beef cattle	liquid manure	52.5	244.7	0.168	2.98	5.1	20.9	0.016	0.31
	solid manure	22.0	91.1	0.151	2.81	5.1	17.3	0.033	0.50
fattening pigs	liquid manure	115.3	746.5	0.210	1.76	4.6	30.4	0.008	0.07
dry sows	liquid manure	71.1	517.5	0.170	2.53	3.7	22.9	0.009	0.11
sows with piglets/weaners	liquid manure	119.2	553.8	0.230	2.55	6.3	31.7	0.013	0.13
laying hens	litter from belts	35.2	425.3	0.310	2.22	1.8	23.6	0.014	0.10
	litter deep pits	44.0	511.5	0.195	2.25	1.5	19.3	0.008	0.08
broilers, turkeys	litter	43.8	349.2	0.292	2.92	3.9	27.0	0.024	0.24

Table 2

Median values of the Cu, Zn, Cd and Pb analyzed in different types of manure.  
For number of samples see table 1.

The lowest Cu- and Zn-values were found for dairy cattle, where heavy metals are only added to the ration according to animal requirements. For beef cattle somewhat higher median values were found, mainly due to some high values. Poultry manure had a slightly higher mean Cu- and mainly Zn-content than cattle manure. The lower content of solid manure as compared to that of liquid manure of dairy and beef cattle as well as pigs can be explained by the "dilution" achieved by adding straw and probably also by the different origin of the samples and the small number of solid manure samples analyzed.

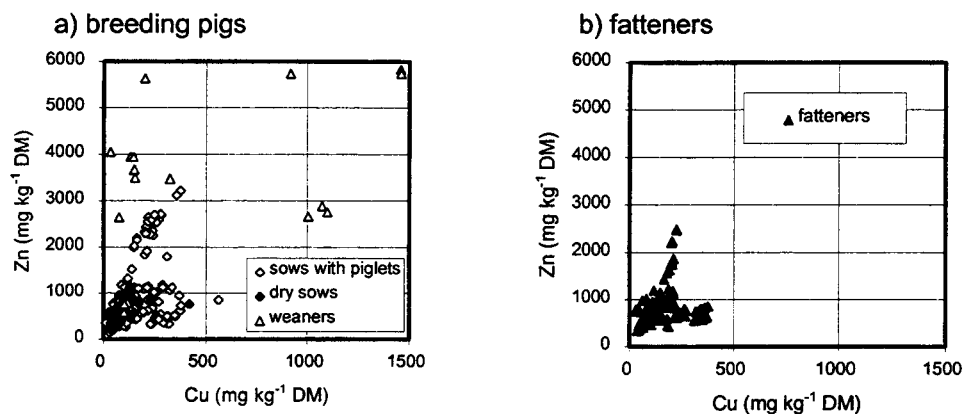

Figure 1  
*Cu and Zn content (mg kg<sup>-1</sup> DM) of pig slurries for breeding pigs a) and for fatteners b). Weaners could only be considered in a separate category if they were moved to a separate compartment after weaning*

The Pb content per unit DM was highest for cattle. This can be explained by the fact that Pb is introduced into the agricultural cycle mainly by deposition from the atmosphere. Animals with a high proportion of roughage will therefore take up higher amounts of Pb than those fed mainly on grains. For Cd there was no clear difference between manure types and animal categories.

For all heavy metals studied, the range between the highest and the lowest values found was considerable (table 3). The fact, that except for poultry, where the number of samples was too low, the median value was always clearly in the lower half of the total range, demonstrates that a few exceptionally high values were responsible for the wide range (see also fig. 1). In the balance experiments, these few high values could always be traced back to high inputs in the feed. Especially for weaners, the Cu and Zn content in the ration often surpassed the recommended value considerably (recommended: 6 mg Cu and 95 mg Zn per kg feed; average content 88 mg kg<sup>-1</sup> Cu, 794 mg kg<sup>-1</sup> Zn; maximum values 169 mg kg<sup>-1</sup> Cu, 2525 mg kg<sup>-1</sup> Zn). Relative to the median value, the range of contents in the manure was highest for Pb. This was probably mainly due to regional differences in Pb-deposition.

In general the heavy metal contents of different manures agreed well with those recently reported for other countries (Chambers et al., 1998; Unwin, 1998). Where Cu and Zn use in feeding is known to differ between countries, this also showed in the manure. Compared to the values cited from different authors by Wilcke and Döhler (1995) the mean heavy metal content of manures in our study were generally lower. The difference is considerable for Cd and Pb in all categories and for Cu and Zn in pig slurry. It is probably mainly due to the rapid reduction of Cd and Pb emissions in the past years and to somewhat lower metal contents in pig rations in Switzerland.

### 3.2. Heavy metal content per unit P

If the heavy metal content is expressed per unit P, all animal species had about the same median value for Cu, and the Zn-content of pig slurry was only slightly higher than that of cattle slurry. This can mainly be explained by the higher P-content of pig slurry. As long as manure is applied in doses adjusted to crop needs, this should insure that heavy metal loads per hectare are not higher for pig than for cattle slurry. Nevertheless, the metal content per unit P also differed considerably from farm to farm, and the maximum values were clearly higher in pig than in cattle slurry.

Animal category	Manure type	Cu	Zn	Cd	Pb
		$\mu\text{g g}^{-1}$ DM			
dairy cattle	liquid manure	13-160	102-395	<0.08-3.2	1.3-50
	slurry	0.5-188	44-716	0.08-1.5	1-17.3
	solid manure	2.5-80	40-412	0.04-3.1	0.09-15.6
beef cattle	liquid manure	12-267	88-938	<0.08-0.80	0.3-14.2
	solid manure	15-51	49-448	<0.08-0.62	1.3-11.9
fattening pigs	liquid manure	30-376	337-2490	<0.08-0.51	0.9-15.8
dry sows	liquid manure	28-418	269-1112	0.09-0.56	1.2-23.9
sows with piglets/weaners	liquid manure	12-1459	146-5832	0.06-1.3	0.34-12.8
laying hens	litter from belts	24-119	379-533	0.25-0.38	1.5-3.0
	litter deep pits	17-486	237-789	0.09-0.42	1.5-4.1
broilers, turkeys	litter	8.4-88	52-437	0.11-0.76	1.7-23.7

*Table 3*  
Range (minimum and maximum) of values found for the Cu, Zn, Cd and Pb content of different types of manure. For number of samples see table 1.

### 3.3. Heavy metal load per hectare

To assess, if heavy metals in manure are an ecological problem or not, the load applied to the land must be compared with the typical plant uptake. Only if this balance is clearly positive, an accumulation will take place, which in the long run might impair soil fertility. With the ecological restrictions Swiss farmers have to fulfill, it can be assumed that manure will not usually be applied in quantities far exceeding the nutrient demand of crops. On the other hand, it is quite common that farmers cover the whole nutrient demand of the crop with manure. The heavy metal load applied with manure can therefore normally be assumed not to exceed the amount applied with the manure dose covering the P demand of the crop. Table 4 therefore shows the metal load in a manure dose equivalent to 70 kg P<sub>2</sub>O<sub>5</sub> which is assumed as a mean crop demand (manure content and crop demand according to Walther et al., 1994). As a simplification only the data for the most important manure types (liquid manure for cattle and pigs) are presented. As can be deduced from the metal content per unit P in table 2, other manure type would not differ much.

	Cu	Zn	Cd	Pb
	g ha <sup>-1</sup> year <sup>-1</sup>			
crop uptake				
meadow 10 t DM year <sup>-1</sup>	55-210	270-580	0.3-1.5	20-62
wheat grain	20-29	164-232	0.21-0.52	0.53-11.1
wheat straw	35-73	79-119	0.86-1.39	18.5-26.4
load with 70 kg P <sub>2</sub> O <sub>5</sub> ha <sup>-1</sup> year <sup>-1</sup>				
liquid manure dairy cattle	124	537	0.57	12.3
liquid manure beef cattle	156	639	0.49	9.5
pig slurry (fatteners)	139	929	0.25	2.2
pig slurry (breeding pigs) <sup>1)</sup>	161	861	0.35	3.7
poultry manure (hens, belts)	56	724	0.43	3.2
poultry manure broilers	118	824	0.73	7.4

<sup>1)</sup> Weighted mean of dry sows (0.4) and lactating sows with piglets/weaners (0.6).

Table 4.

*Comparison of the heavy metal uptake of an intensive meadow (yield: 10 t DM) or wheat (yield: 6 t grains, 7.5 t straw) with the heavy metal load in the dose of different manures equivalent to 70 kg ha<sup>-1</sup> P<sub>2</sub>O<sub>5</sub>. Range of heavy metal content of grass and wheat according to von Steiger and Baccini (1990).*

If the total phosphorus demand of the crop is covered by manure of average metal content, the heavy metal load would only clearly surpass crop uptake in the case of Zn from pig and poultry manure.

If the maximum heavy metal content found in our study would be assumed, the Cu and Zn load would by far exceed crop uptake and even maximum loads allowed for sewage sludge (1000 g ha<sup>-1</sup> Cu and 3333 g ha<sup>-1</sup> per year). The Cd and Pb dose per hectare with mean manure contents lies clearly below crop uptake for all animal categories.

A dose of 70 kg P<sub>2</sub>O<sub>5</sub> is equivalent to 2.0 Swiss livestock units (LU). At the average Swiss livestock density of about 1.3 LU ha<sup>-1</sup> the load per hectare at mean manure content would substantially surpass crop uptake only in the case of Zn in pig and poultry manure. Provided that the heavy metal content of the manure is not above average, animal husbandry at such animal density can therefore be assumed not to cause metal loads that harm soil fertility. Nevertheless, the total heavy metal load can only be assessed if the heavy metal deposition and the input due to other fertilizers and pesticides is also known. The median value of five deposition monitoring sites in agricultural regions of Switzerland (1990-1994) was 41 g ha<sup>-1</sup> Cu, 159 g ha<sup>-1</sup> Zn, 1.1 g ha<sup>-1</sup> Cd and 37 g ha<sup>-1</sup> Pb (BUWAL, 1995; for Cu Studer, personal communication). The average metal load per hectare of agricultural land (excluding alpine pastures) from mineral fertilizers in Switzerland in 1990 (Frei et al., 1993) can be calculated at

6.5 g ha<sup>-1</sup> Cu, 42 g ha<sup>-1</sup> Zn, 1.0 g ha<sup>-1</sup> Cd and 4.0 g ha<sup>-1</sup> Pb. The metal input due to sewage sludge, compost and pesticides can be assumed to be of local importance only, because they are used only on a small proportion of the land. Using these data it can be estimated that normal agricultural management at average animal density and without high heavy metal inputs in sewage sludge, compost or pesticides does not lead to excessive heavy metal loads to the land. A slight surplus exists for Zn on pig and poultry farms and for Cd on farms using mineral P fertilizers. The latter can be assumed to have decreased recently because of new limits for the Cd content of fertilizers introduced in 1992 (50 g Cd per t P).

### **3.4. Total heavy metal load in manures**

In 1995 the total heavy metal load in manures in Switzerland amounted to 94 t Cu, 453 t Zn, 0.375 t Cd and 7.43 t Pb (table 5). Of this load 64 % (Zn) to 87 % (Pb) were in cattle manure. This is not surprising, as cattle also contributed 70-80 % of the N and P excretion. Compared to the heavy metal load in manure calculated for 1990 with heavy metal contents found in the preliminary study between 1988 and 1991 (Menzi et al., 1993), the load decreased by 28 % for Cu, 17 % for Zn, 56 % for Cd and 49 % for Pb. Only 6 % (Cu and Zn) and 4 % (Cd and Pb) of this decrease (% of load 1990) was due to the reduction of the animal number. This illustrates a noticeable success of the efforts to reduce the Cu- and Zn-content in animal feed and of air protection measures in the case of Cd and Pb. It can be expected, that the reduction will continue thanks to new limits imposed on the Cu and Zn content of feed and continuing air protection measures.

A comparison of the heavy metal load in manure with that in other fertilizers shows that manure is responsible for about two thirds of the Cu and Zn load in fertilizers and for about 20 % of the Cd and Pb load. For the Cd and Pb load mineral fertilizers and sewage sludge respectively are the most important sources.



	Cu	Zn	Cd	Pb
	t year <sup>-1</sup> (% of total load from animal husbandry)			
1995 (animal numbers 1995, metal contents see table 2)				
cattle	67.5 (71)	291 (64)	0.301 (80)	6.458 (87)
pigs	19.7 (21)	122 (27)	0.038 (10)	0.364 (5)
poultry	1.9 (2)	18 (4)	0.013 (3)	0.112 (2)
horses, sheep, goats	5.0 (5)	22 (5)	0.023 (6)	0.497 (7)
total	94.1 (100)	453 (100)	0.375 (100)	7.431 (100)
1990 (animal numbers 1990, metal contents according to Menzi et al. 1993)				
cattle	73.0 (56)	344 (63)	0.697 (83)	12.822 (88)
pigs	50.2 (38)	164 (30)	0.086 (10)	0.784 (5)
poultry	2.3 (2)	16 (3)	0.016 (2)	0.133 (1)
horses, sheep, goats	4.7 (4)	22 (4)	0.045 (5)	0.832 (6)
total	130.2 (100)	547 (100)	0.843 (100)	14.570 (100)
load in other fertilizers in 1990 (Frei et al. 1993)				
mineral fertilizers	7	45	1.010	4.3
sewage sludge, compost	44	160	0.490	30.6
Reduction of load in manure between 1990 and 1995 (% , negative values = increase)				
cattle	7.5 %	15.4 %	56.8 %	49.6 %
pigs	60.7 %	26.0 %	55.5 %	53.5 %
poultry	20.0 %	-11.7	17.1 %	15.5 %
horses, sheep, goats	-6.1 %	2.4 %	49.2 %	40.3 %
total	27.7 %	17.2 %	55.5 %	49.0 %

Table 5

*Heavy metal load in manures of different animal species in Switzerland in 1995 and comparison with the load in manures and other fertilizers in 1990.*

#### 4. Conclusions

Heavy metal contents vary considerably between manures from different animal types and from different farms. The highest median values were found in pig slurry, especially that of weaners or sows with piglets/weaners. Maximum values were up to ten times higher than median values. The great variability between farms shows that management (especially feed content) is of major importance for the heavy metal content in manures. Results from many farms show that animal production with low heavy metal turnover is possible. Therefore, the extremely high values found on some farms should be reduced immediately. Pig production (especially weaners) would have the biggest potential for improvements.

Manure is the most important cause of Cu and Zn input to Swiss crop production. Even though the content of these elements in manure has gone back considerably in the past years, the load per hectare is still near or above crop uptake at average animal density. Thus, an accumulation will take place. To avoid this and to secure long term soil fertility, the heavy metal content in animal feed should not surpass animal requirements. This limitation is especially justified and feasible for Cu, where contents in pig feed are often below the range where a clear positive influence on animal growth can be expected but far above official recommendations and animal requirements.

## **5. Acknowledgments**

We thank all the farmers who participated in the experiments for their collaboration. The study was financially supported by the Swiss Agency for the Environment, Forests and Landscape (BUWAL).

## **6. References**

**Buwal**, 1991 : Schwermetall und Fluor in Mineraldüngern. Schriftenreihe Umwelt No. 162, 44 pages.

**Buwal**, 1993: Nationales Bodenbeobachtungsnetz: Messresultate 1985-1991 : Schriftenreihe Umwelt No. 200, 175 pages.

**Buwal**, 1995: NABEL Luftbelastung 1994 : Schriftenreihe Umwelt No. 244

**Candinas T., Chassot G., Besson J.-M. and Lischer P.**, 1991 : Nutz- und Schadstoffe im Klärschlamm. Schweizerische Landwirtschaftliche Forschung 30, 45-59

**Chambers B.J., Nicholson F.A., Soloman D.R. and Unwin R.**, 1998 : Heavy metal loadings from animal manures to agricultural land in England and Wales. In: Martinez J., 1998: Proc. of the FAO-Network on Recycling Agricultural, Municipal and Industrial Residues in Agriculture (RAMIRAN 98) conference, Rennes (F) 26-29 May 1998 (This volume).

**Frei U., Candinas T., Chardonnens M. and Besson J.-M.**, 1993 : Stellung des Kompostes in der Düngung. Schriftenreihe der Forschungsanstalt für Agriculturnchemie und Umwelthygiene (FAC) No. 13, 65 pages

**Keller T. and Desaulles A.**, 1997 : Flächenbezogene Bodenbelastung mit Schwermetallen durch Klärschlamm. Schriftenreihe der Eidg. Forschungsanstalt für Agrarökologie und Landbau (FAL) No. 23, 82 pages

**Kessler J., Zogg M. and Bächler E., 1994 :** Phosphor, Kupfer und Zink im Schweinetrog. Agrarforschung 1, 480-483

**Menzi H., Haldemann C. and Kessler J., 1993 :** Schwermetalle in den Hofdüngern - ein Thema mit Wissenslücken. Schweizerische Landwirtschaftliche Forschung 32, 159-167

**Studer K., Gsponer R. and Desaulles A., 1995 :** Erfassung und Ausmass der flächenhaften Kupferbelastung in Rebbergböden der Schweiz. Schriftenreihe der Forschungsanstalt für Agriculturnchemie und Umwelthygiene (FAC) No. 20, 44 pages

**Unwin R., 1998 :** European survey on heavy metals in manure. In: Martinez J., 1998: Proc. of the FAO-Network on Recycling Agricultural, Municipal and Industrial Residues in Agriculture (RAMIRAN) conference, Rennes (F) 26-29 May 1998 (This volume)

**Von Steiger B. and Baccini P., 1990 :** Regionale Stoffbilanzierung von landwirtschaftlichen Böden mit messbarem Ein- und Austrag. Bericht des Nationalen Forschungsprogrammes "Boden", 38, 78 pages

**Von Steiger and Obrist J., 1993 :** Available databases for the assessment of regional mass balances in agricultural land. In: Schulin R, Desaulles A., Webster R. and von Steiger B. (Eds.), Soil Monitoring. Birkhäuser Verlag Basel, 35-46

**Walther U., Menzi H., Ryser. P., Flisch R., Jeangros B., Kessler W., Maillard A., Siegenthaler A.F. and Vuilloud P.A., 1994 :** Grundlagen für die Düngung im Acker- und Futterbau. Agrarforschung 1/7, 1-40

**Wilcke W. and Döhler H., 1995 :** Schwermetalle in der Landwirtschaft. Arbeitspapier 217, Kuratorium für Technik und Bauwesen in der Landwirtschaft, 98 pages

## Effects of solid phase from pig slurry on soil and wheat micronutrient's content.

*Influence de l'addition de la fraction solide du lisier de porc, sur la teneur en micro-éléments dans le sol et le blé.*

**Fernanda Cabral , Ernesto Vasconcelos and Claudia M d S Cordovil\***

Instituto Superior de Agronomia - DQAA, Tapada da Ajuda,

1399 Lisboa Codex, Portugal.

E-mail : Fmcabral@popmail.isa.utl.pt

### Abstract

*A two years lysimeter experiment was conducted using wheat plants on two texturally contrasting soils (soil A and soil B). The main objective of this study was to evaluate the influence of increasing doses (5, 10, 15, 20 and 25 t.ha<sup>-1</sup>) of solid phase from pig slurry (SP) on soil extractable copper (Cu), zinc (Zn), iron (Fe) and manganese (Mn) content, as well as on wheat micronutrient's composition and uptake. As the control, a basic dressing of NPK fertiliser was applied. Results showed that increasing additions of SP significantly enhanced extractable Cu, Zn, Fe and Mn content on the topsoil for both soils tested. Similar results were obtained only for subsoil A. A significant increase in the content of Fe, Mn and Zn in the plants as well as its uptake was observed from increasing doses of SP. On the contrary, Cu content in the plants was not significantly affected. Finally, a strong pH effect was exerted in the Mn and Zn uptake by the plants.*

Key words : wheat, solid phase from pig slurry, micronutrients

### Résumé

Un essai en lisimètres a été conduit pendant deux années, avec deux sols à textures différenciées (sol A et sol B), utilisant du blé. L'objectif de cette étude, a été celui d'évaluer l'influence de l'addition de différentes doses (5, 10, 15, 20 et 25 t ha<sup>-1</sup>) de la fraction solide du lisier de porc (FS) dans les quantités de cuivre (Cu), zinc (Zn), fer (Fe) et manganèse (Mn) extractibles du sol ainsi que dans la teneur et l'absorption de ces éléments par le blé. Un témoin NPK a été effectué. L'accroissement des quantités de FS additionnées au sol, a significativement augmenté les teneurs de Cu, Zn, Fe et Mn extractible dans la couche superficielle des deux sols utilisés. Le même effet a été produit sur les teneurs de Fe, Mn et Zn dans les plantes, ainsi que sur les quantités exportées. Par contre, la teneur de Cu dans le blé n'a pas été significativement influencé. Finalement, le pH a eu un fort effet sur l'absorption du Mn et du Zn par les plantes.

Mots-clés : blé, fraction solide du lisier de porc, lisimètres, microéléments

## 1. Introduction

In the last decades, intensification of pig husbandry has resulted in an increase of soil independent farms conducting to an accumulation of large amounts of pig manure. To overcome the problem of excessive pig slurries, Bianchi and Catalano (1993) proposed a technology consisting on a separation of the solid phase of fresh pig slurry from the liquid using a centrifuge with horizontal axis (3,000 rpm) allowing the concentrated liquid phase to come out of the centrifuge by means of evaporation panels before being reinjected into fresh pig slurry. The solid phase (SP) obtained is very different from pig slurries either in agricultural or environmental terms, since it has a much higher content in P, Ca, Mg and micronutrients and a much lower content in K,  $\text{NO}_3\text{-N}$  and  $\text{NH}_4\text{-N}$  than pig slurries (Vasconcelos et al., 1997). This SP can either be used as an organic fertiliser, before or after composting, replacing traditional manure whose availability is often very poor (Giusquiani et al., 1995; Gigliotti et al., 1996). Because composting is an expensive process, the direct use on the soil can be a mean of reducing costs if it proves to be efficient while preserving environmental quality (Vasconcelos and Cabral, 1996; Vasconcelos et al., 1997).

The fertiliser value of SP is mainly determined by the technique used in the separation process, nutrient content and digestibility of pig's feed. The mineral composition of feed depends on its constituents, the fertility of the soil on which it was produced and the amounts of additives, e.g., copper sulphate and zinc sulphate. Copper sulphate is added to pig feed to increase feed efficiency and to control dysentery, while zinc sulphate is usually added to prevent copper toxicity and zinc deficiency in the animals (Christie, 1990). Copper and zinc content of the feed for fattening pigs has been lowering in agreement with European Union (EU) regulations. However, as the most of the dietary copper and zinc are excreted, there is a widespread concern about the consequences and largely irreversible retention of those toxic metals in agricultural soils due to long term SP applications. On the other hand the eventual presence of considerable concentrations of some other potentially toxic elements including manganese (Mn) and iron (Fe) may constitute one of the main problems associated with successive applications of SP to soils. In fact, these elements can leach through the soil profile and may pollute groundwater or accumulate in the upper soil layer and can be toxic to plants.

Thus, the main purpose of the present study was to evaluate the influence of the amendment with increasing rates of solid phase from pig slurry (SP), on Cu, Zn, Fe and Mn, content on both topsoil (0 -20 cm) and subsoil (20 - 50 cm) of two texturally contrasting soils. Wheat mineral composition and uptake by the plants was also investigated.

## 2. Material and methods

A two years (1993 to 1995) completely randomised design wheat experiment was conducted in lysimeters (1m<sup>2</sup> of available area and 1 m in depth) filled with either a Cambic Arenosol (soil A) or Dystric Cambisol (soil B) (Table 1).

Determinations	Soil A topsoil	Soil A subsoil	Soil B topsoil	Soil B subsoil
Texture	sandy	—	silt sandy	—
Coarse sand (%)	69.50	nd	38.60	nd
Fine sand (%)	0.44	nd	33.40	nd
Silt (%)	9.40	nd	17.10	nd
Clay (%)	2.40	nd	10.90	nd
CEC cmol (+) kg <sup>-1</sup>	1.22	0.85	3.26	1.81
pH (H <sub>2</sub> O)	6.23	6.26	6.12	5.33
pH (KCl)	5.68	4.87	4.60	3.68
O.M. (%)	0.61	0.37	1.07	0.44
Extractable micronutrients				
Fe (mg kg <sup>-1</sup> )	29.62	14.60	38.50	39.50
Cu (mg kg <sup>-1</sup> )	0.81	0.80	1.66	0.30
Zn (mg kg <sup>-1</sup> )	6.94	1.20	2.81	0.80
Mn (mg kg <sup>-1</sup> )	7.77	2.10	3.55	6.40

Table 1.  
Some physical and chemical characteristics of the soils

Treatments were replicated twice and consisted of: control (NPK), and 5, 10, 15, 20 and 25 t ha<sup>-1</sup> of solid phase from pig slurry (SP), on a fresh weight basis (Table 2). A basic dressing of a NPK fertiliser consisting of: 50 kg N ha<sup>-1</sup> (ammonium sulphate, 20.5% N), 58 kg K ha<sup>-1</sup> (potassium chloride, 49.8 % K) and 17.5 kg P ha<sup>-1</sup> (superphosphate, 7.9 % P) was performed. Two N topdressing (at tillering and just before head development) were applied in every treatment and consisted of 2 x 25 kg N ha<sup>-1</sup> (ammonium nitrate, 26% N) application.

Determinations	1 <sup>st</sup> year	2 <sup>nd</sup> year	Determinations	1 <sup>st</sup> year	2 <sup>nd</sup> year
Moisture %	81.10	75.20	Fe (mg kg <sup>-1</sup> )	1146.00	1182.70
Org. matter %	12.53	17.12	Cu (mg kg <sup>-1</sup> )	128.00	127.60
pH	8.47	8.22	Zn (mg kg <sup>-1</sup> )	201.00	292.30
C/N	13.98	11.60	Mn (mg kg <sup>-1</sup> )	101.60	128.50

Table 2.  
Chemical composition of solid phase from pig slurry (SP).

In the second year of the experiment, levels of mineral fertilisers and SP added to soils were the same as the first year.

At the beginning of the experiment, lysimeters were watered with sufficient demineralized water to allow seeds germination. Twenty-five grams of wheat seeds ( $250 \text{ kg ha}^{-1}$ ) were sown in rows on each lysimeter.

At the end of each year experiment soil samples were taken from each lysimeter and analysed. Plants were harvested, weighed, and chemical analysis performed.

### **Analytical Procedures**

The particle size distribution (texture) of the soils was determined by the pipette method (Day, 1965), and organic carbon (C) determined by dry combustion at  $1200^\circ\text{C}$ , using a Strohlein (Strohlein and Co., Dusseldorf, Germany) apparatus. Based on the assumption that soil organic matter is 58% carbon, organic matter content was calculated by multiplication of the percentage of organic carbon by the factor 1.724.

Organic matter in the SP was determined by loss-on-ignition at  $350\text{-}400^\circ \text{C}$  for seven to eight hours.

Cu, Fe, Zn and Mn content in the SP and plant tissues was determined by atomic absorption spectrophotometry in a Pye Unicam SP-9 apparatus (Cambridge, UK), after hydrochloric acid mineralisation of the ash (Martí and Muñoz, 1957).

Extractable Fe, Cu, Zn and Mn in the soils were extracted by Lakanen & Ervio method (Lakanen and Ervio, 1971) and determined by atomic absorption spectrophotometry.

### **Statistical Analysis**

Results from the study were subjected to one-way ANOVA, followed by Scheffe F-test at  $p < 0.05$  (Danzart, 1986).

## **3. Results and discussion**

### **Soil extractable Fe, Cu, Zn and Mn**

At the end of the first year of the experiment increasing application rates of SP did not significantly affect extractable Fe, Cu, Zn and Mn content on soil A either for topsoil or subsoil (data not shown). However, on soil B for topsoil significant differences between treatments corresponding to  $5 \text{ t ha}^{-1}$  and  $25 \text{ t ha}^{-1}$  SP applications were detected for extractable Cu, Zn and Mn. In fact, extractable Cu increased from  $1.5$  to  $3.7 \text{ mg kg}^{-1}$ , extractable Zn from  $3.9$  to  $6.2 \text{ mg kg}^{-1}$  and extractable Mn from  $5.0$  to  $7.7 \text{ mg kg}^{-1}$ .

Comparing soils after the second year of the experiment both had significant increases of extractable Fe, Cu, Zn and Mn in the surface layer from the increasing levels of SP applied (Table 3). These results are supported by several authors (Christie, 1990; Siegenthaler, 1990; Warman, 1990, 1993) although their studies are specifically referred to pig slurries. On the other hand, subsoil of both soils tested show a completely different behaviour. In fact, while for subsoil A a significant enhance was detected for extractable Cu, Zn and Mn content with increasing application rates of SP, for subsoil B no significant differences were detected. Since the main factors responsible for micronutrients availability are soil pH, cation exchangeable capacity (CEC), organic matter and clay content (Verloo, 1990), results obtained for subsoil A are probably associated to the low CEC and small organic matter and clay content present in that soil (Table 1).

Treat.	Soil A				Soil B			
	Fe	Cu	Zn	Mn	Fe	Cu	Zn	Mn
	2 <sup>nd</sup>	year	topsoil		2 <sup>nd</sup>	year	topsoil	
NPK	26.80 d	1.30 c	9.40 c	7.50 c	37.40 c	1.35 d	5.55 c	4.35 e
5 t	31.60 cd	2.36 bc	12.30 c	7.90 c	40.85 c	1.95 d	9.55 bc	5.60 de
10 t	39.80 bc	2.76 b	18.40 b	9.80 bc	51.90 d	3.55 c	10.90 b	8.05 cd
15 t	50.10 b	4.10 b	18.90 b	11.20 b	58.95 bcd	4.35 c	11.20 b	9.55 bc
20 t	55.70 b	4.50 b	20.00 b	11.50 ab	74.50 b	5.45 b	12.15 b	11.60 ab
25 t	68.00 a	6.00 a	26.90 a	14.50 a	84.30 a	6.50 a	18.10 a	13.85 a
	2 <sup>nd</sup>	year	subsoil		2 <sup>nd</sup>	year	subsoil	
NPK	20.30 b	1.00 c	1.30 d	4.00 b	54.00 a	1.20 a	1.30 a	6.55 a
5 t	21.30 b	1.30 bc	1.40 d	3.50 b	54.80 a	1.30 a	1.25 a	7.75 a
10 t	22.80 b	1.30 bc	1.80 cd	3.50 b	55.50 a	1.30 a	1.10 a	8.60 a
15 t	24.50 b	1.30 bc	2.90 bc	5.10 a	54.65 a	1.45 a	1.05 a	6.50 a
20 t	25.00 b	1.70 ab	4.00 b	5.10 a	59.75 a	1.60 a	1.45 a	8.30 a
25 t	33.70 a	2.20 a	7.50 a	6.10 a	57.05 a	1.50 a	1.50 a	7.70 a

\* Values followed by the same letter are not significantly different as judged by Scheffe - F test ( $p < 0.05$ ).

**Table 3**  
*Extractable Fe, Cu, Zn and Mn ( $\text{mg kg}^{-1}$ ) on both soils at the end of the two-year experiment.*

### Plants Fe, Cu, Zn and Mn composition and uptake

Fe, Cu, Zn and Mn composition of wheat plants (grain and straw) after the second year of the experiment are given in Table 4. Uptake of those elements by the plants are shown in Table 5.



Soil A (2 <sup>nd</sup> year)								
Treat.	Grain				Straw			
	Fe	Cu	Zn	Mn	Fe	Cu	Zn	Mn
NPK	65.0 bc	14.8 a	43.3 a	24.0 a	170.5 d	16.8 a	66.0 a	16.3 a
5 t	54.0 c	12.3 a	29.3 b	9.5 b	162.7 d	13.5 a	37.6 c	8.5 b
10 t	53.5 c	13.0 a	36.8 ab	8.5 b	173.0 d	16.5 a	38.4 c	8.3 b
15 t	57.3 c	11.0 a	37.5 a	8.9 b	261.0 c	16.0 a	47.5 bc	9.3 b
20 t	75.5 ab	11.0 a	37.3 a	11.6 b	319.3 b	15.0 a	48.7 bc	9.5 b
25 t	80.3 a	12.0 a	42.5 a	18.0 a	378.8 a	15.5 a	62.3 ab	14.8 a

Soil B (2 <sup>nd</sup> year)								
Treat.	Grain				Straw			
	Fe	Cu	Zn	Mn	Fe	Cu	Zn	Mn
NPK	66.0 a	5.7 a	47.0 c	29.3 abc	263.0 b	8.3 a	44.0 b	52.0 a
5 t	61.3 a	5.7 a	49.7 bc	23.7 c	253.7 b	6.3 a	43.3 b	37.7 b
10 t	62.7 a	8.3 a	51.3 abc	26.0 bc	290.0 ab	6.7 a	51.7 a	38.0 b
15 t	69.0 a	8.7 a	58.3 ab	29.0 bc	315.7 a	8.0 a	53.0 a	38.3 b
20 t	72.3 a	8.0 a	58.7 ab	31.7 ab	318.0 a	8.0 a	54.0 a	38.7 b
25 t	75.0 a	9.3 a	60.7 a	34.3 a	327.0 a	8.3 a	56.3 a	41.3 b

\* Values followed by the same letter are not significantly different as judged by Scheffe - F test ( $p < 0.05$ ).

**Table 4**  
*Fe, Cu, Zn and Mn composition ( $\text{mg kg}^{-1}$ ) of wheat plants (grain and straw) grown on both soils at the end of the experiment.*

Soil A (2 <sup>nd</sup> year)								
Treat.	Grain				Straw			
	Fe	Cu	Zn	Mn	Fe	Cu	Zn	Mn
NPK	17.81 c	4.02 a	11.88 b	6.59 a	90.86 d	8.91 a	35.08 a	8.64 a
5 t	13.29 d	3.76 a	7.18 c	2.33 c	57.41 e	4.70 a	13.36 c	2.96 b
10 t	15.18 cd	3.74 a	10.40 b	2.42 bc	74.19 de	7.08 a	16.46 c	3.54 b
15 t	16.23 cd	3.11 a	10.62 b	2.87 bc	128.97 c	7.86 a	23.42 b	4.57 b
20 t	24.88 b	3.53 a	12.09 b	3.77 b	167.36 b	7.84 a	25.46 b	4.97 b
25 t	30.11 a	4.50 a	15.87 a	6.75 a	225.54 a	9.24 a	37.47 a	8.82 a

Soil B (2 <sup>nd</sup> year)								
Treat.	Grain				Straw			
	Fe	Cu	Zn	Mn	Fe	Cu	Zn	Mn
NPK	13.17 ab	1.06 ab	9.10 a	5.64 ab	81.29 d	2.25 cd	7.36 d	16.35 ab
5 t	11.36 b	0.93 b	8.85 a	4.26 c	63.53 e	1.64 a	11.39 c	9.58 c
10 t	11.00 b	1.42 ab	8.61 a	4.97 bc	84.90 d	1.95 cd	13.08 c	10.58 bc
15 t	14.27 b	1.77 ab	11.85 a	6.00 ab	107.34 c	2.58 bc	17.93 b	13.44 b
20 t	15.23 a	1.71 ab	12.17 a	6.64 a	121.76 b	3.42 ab	20.68 ab	14.82 ab
25 t	15.63 a	2.01 a	11.99 a	6.91 a	140.55 a	3.49 a	22.83 a	17.52 a

\* Values followed by the same letter are not significantly different as judged by Scheffe - F test ( $p < 0.05$ ).

**Table 5**  
*Fe, Cu, Zn and Mn uptake ( $\text{mg/lysimeter}$ ) by wheat plants grown on soil A at the end of each year of the experiment*

After the first year of the experiment, no significant differences were observed on plant micronutrients content and uptake (data not shown). At the end of the second year, Cu content in the plants was not significantly affected from increasing application doses of SP on both soils tested. However, Cu uptake increased significantly from application additions of SP greater than  $10 \text{ t ha}^{-1}$  on soil B. Since during the two years of the experiment the largest yields were obtained from the greatest rates of SP applied (Vasconcelos et al., 1997), Cu content in the plants correspondent to those treatments is probably due to a dilution effect. Nevertheless, as the lowest pH values for both soils occurred in control (Figure 1), plants Cu uptake is most likely due to a pH effect. This fact is consistent with the finding that for both soils, only for the treatments where the greatest rates of SP were applied, the concentration effect of that element over passed the pH effect.

Plants Zn content significantly increased from increasing additions of SP, especially on soil B. Similarly, Zn uptake by the plants was strongly affected from increasing levels of SP. For control plants, a similar behaviour occurred for Zn content and uptake as for Cu. Also in this case results obtained seems to be related to a pH effect.

Fe content in the plants as well as its uptake on both soils was enhanced with increasing doses of SP applied, this increase being particularly evident at the end of the second year of the experiment.

Finally the greatest content in Mn in the plants on both soils was always present at the NPK treatment. This fact is most likely related to the increase of pH values due to the increasing additions of SP applied to soils (Figure 1), that was conducive to a reduction in Mn uptake by the plants. However, the pH effect did not affect so intensively the treatment correspondent to the greatest amount of SP applied ( $25 \text{ t ha}^{-1}$ ) probably due to the greatest concentration in Mn present on the topsoil. Furthermore, a comparison between the SP treatments allows us to conclude that increasing doses of SP led to an increase of Mn in the plants content and uptake with particular relevance at the end of the experiment.

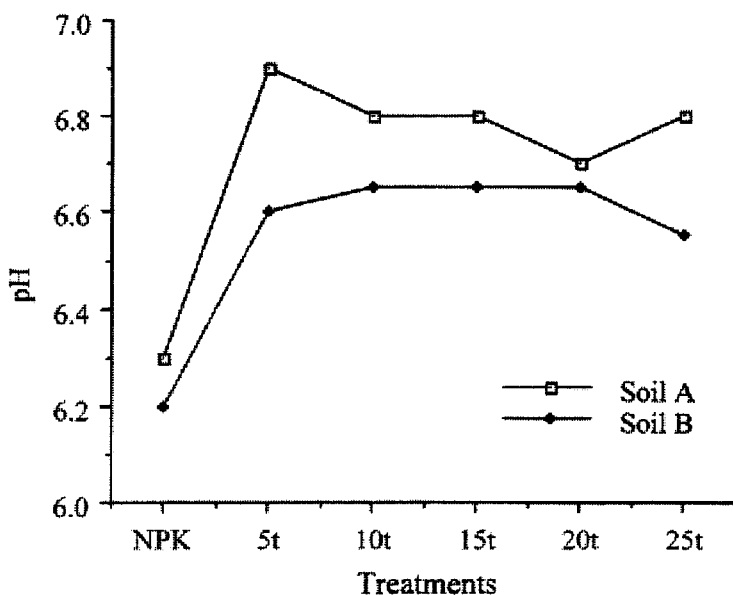

Figure 1  
Soil pH values after two years experiment.

#### 4. Conclusions

From the results obtained the following conclusions can be drawn :

- Increasing doses of solid phase from pig slurry (SP) led to a significant enhance of extractable Cu, Zn, Fe and Mn content on the topsoil of the two texturally contrasting soils tested. Similar results were detected only for subsoil A. This fact is probably associated to the low fixation capacity presented by soil A due to its small cation exchange capacity (CEC) and small organic matter and clay content.
- Increasing additions of SP led at the end of the two years experiment and for both soils to an increase in the Fe, Mn and Zn content in the plants as well as in its uptake. On the contrary, Cu content in the plants was not significantly affected by SP applications to the soils.
- pH values exert a strong effect in the Mn and Zn uptake by the plants. In fact, the uptake of these elements was always greater for NPK treatment except when 25 t. ha<sup>-1</sup> of SP were applied. In this particular case it is possible to conclude that the concentration effect was high enough to over pass the pH effect.

➤ According to the results obtained by the same authors (Vasconcelos et al., 1997), application doses of SP greater than  $10 \text{ t ha}^{-1}$  led to a strong increase in the available phosphorus (P) for both topsoil and subsoil of the two soils tested, that under leaching conditions can cause surface and ground waters contamination. This fact, and taking into account results from the present study allow us to conclude that the success of SP as an organic fertiliser, without causing detrimental environmental effects, will depend on the convenient monitorisation of its utilisation considering not only the application doses but also physical and chemical characteristics of the soils.

## 5. Acknowledgements

The authors acknowledge Mrs. Isabel Carvalho and Mrs. Paula Gonçalves for technical assistance. This study was supported in part by grants from JNICT.

## 6. References

- Bianchi, B. and P. Catalano.** 1993. Studio teorico dello scambio di massa in painelli evaporativi. V Convegno Nazionale A.I.G.R. Maratea. VI: 7 - 11.
- Christie, P.** 1990. Accumulation of potentially toxic metals in grassland from long - term slurry application. p. 125 - 130. In: R. Merckx, H. Vereecken and K. Vlassak (eds). Fertilization and the Environment, Leuven, Belgium.
- Day, P.R.** 1965. Particle fractionation and particle size analysis. p. 19 -59. In: Black C.A. et al. (eds). Methods of soil analysis Part 1 American Society of America, Madison, WI.
- Danzart, M.** 1986. Univariate procedures. p. 19-59. In: J R Pigott (ed) Statistical procedures in food research. Elsevier Applied Science Publishers, London, England.
- Gigliotti, G., D. Businelli and P.L. Giusquiani** 1996. Trace metals and distribution in corn plants grown on a 6- year urban waste compost amended soil. Agric. Ecos. Environ. 58:199 -206.
- Giusquiani, P.L., M. Pagliai, G. Gigliotti, D. Businelli and A. Benetti.** 1995. Urban waste compost: effects on physical, chemical, and biochemical soil properties. J. Environ. Qual. 24:175-182.

**Lakanen, E. and R. Ervio.** 1971. Comparison of eight extractants for the determination of plant available micronutrients in soils. *Acta Agr. Finn.* 23:223-232.

**Martí, F.B. and J.R. Munóz.** 1957. *Flame Photometrie.* Elsevier Publishing Company, London, England.

**Marti, F.B. and Munóz, J.R..** 1957. *Flame Photometrie.* Elsevier Publishing Company, London, England.

**Siegenthaler, A.F. and W. Stauffer.** 1990. Environmental effects of long-term slurry and sewage sludge application: reasons and measures. p. 82-89. In: P. L'Hermité (ed.). *Treatment and use of sewage sludge and liquid agricultural wastes.* Elsevier Applied Science Publishers, London, England.

**Vasconcelos, E. and F. Cabral.** 1996. Influence of the concentrated pig slurry on soil and corn fodder yield and chemical composition in presence of N top dressing. *Fert. Res.* 45:25 -29.

**Vasconcelos, E., F. Cabral and C. M d S Cordovil.** 1997. Effects of solid phase from pig slurry on soil chemical characteristics, nitrate leaching, composition and yield of wheat. *J. Plant Nutr.* 20 (7&8) : 939-952.

**Verloo, M. and G. Willaert.** 1990. Direct and indirect effects of fertilization practices on heavy metals in plants and soils. p. 79-87. In: R. Merckx, H. Vereecken and K. Vlassak (eds). *Fertilization and the Environment,* Leuven, Belgium.

**Warman P.R.** 1990. Fertilization with manures and legume intercrops and their influence on Brassica and Tomato growth and on tissue and soil copper, manganese and zinc. *Biol. Agric. Hortic.* 6:325-335.

**Warman P.R.** 1993. Influence of animal manures on extractable micronutrients, greenhouse tomatoes and subsequent Swiss chard crops. p. 397-401. In M.A.C. Frago and M. L. van Beusichem (eds.). *Optimization of Plant Nutrition.* Kluwer Academic Publishers, The Netherlands.

## Hygienic quality of source separated urine based on the analysis of faecal indicator bacteria

*Qualité hygiénique de l'urine séparée à la source  
à travers l'analyse d'un indicateur bactérien fécal.*

**Hoglund C, Stenström T.A, Sundin A.**

Department of Water and  
Environmental Microbiology  
Swedish Institute for Infectious Disease  
Control,  
S-105 21 Stockholm, Sweden  
E-mail : Caroline.Hoglund@smi.ki.se

**Jönsson H, Vinneras B.**

Department of Agricultural Engineering  
Swedish University of Agricultural  
Sciences  
PO Box 7033,  
S-750 07 Uppsala, Sweden.

### Abstract

*Human urine is the largest contributor of nutrients to household wastewater. The re-use of urine as a fertiliser in agriculture would reduce the loads on wastewater treatment plants and the impact on recipients. An important criteria for recirculated products from a sewage system is that the risk for transmission of disease should be low. In a urine source separating system faeces may contaminate the collected urine through the toilet. Concentrations of faecal indicator organisms were measured in 14 urine collection tanks at two occasions. *E. coli* was seldom found; in 84% of the samples the concentration was below the detection limit of 10 cfu/ml. Clostridia was found in varying amounts, ranging from 1 cfu/ml to 2000 cfu/ml. Faecal streptococci occurred in large and varying amounts with 76% of the samples having concentrations above 1000 cfu/ml, thus indicating a growth within the systems. Total coliforms were found in varying amounts with an average of 470 cfu/ml. For all indicator bacteria, concentrations were generally higher in the sediment layer present on the bottom of the collection tanks. Samples were also collected from a urine storage tank during a period of four months. On the last sampling occasion concentrations of all indicator bacteria except clostridia were below detection limits. The results correspond well with laboratory experiments where the die-off of faecal indicator bacteria in urine were studied. At the conditions prevailing in the urine tanks *E. coli* had a D-value below one day. Faecal streptococci was reduced from  $10^6$  cfu/ml to <10 cfu/ml in approximately five months whereas clostridia shows no reduction during 36 days. Thus, after the six month storage generally applied for source separated urine, the hygienic quality of the urine can be considered as satisfactory.*

**Keywords :** Hygiene, faecal indicators, source separation, urine separation.

## Résumé

L'urine humaine contribue largement à l'apport en éléments nutritifs des eaux usées domestiques. La ré-utilisation de l'urine en tant que fertilisant en agriculture réduirait d'autant la charge sur les stations de traitement et l'impact du rejet en milieu naturel. Un critère important pour la recirculation des produits issus d'un système d'eaux usées est le risque de transmission de maladies qui doit être minimum. Dans un système de séparation de l'urine à la source, les faeces peuvent contaminer l'urine collectée via les toilettes. Les concentrations en indicateurs fécaux ont été mesurées dans 14 cuves de stockage à 2 périodes. *E.coli* était rarement présent ; dans 84% des échantillons la concentration se situait en dessous de la limite de détection soit 10 cfu/ml. *Clostridia* était présente à des concentrations variables, allant de 1 à 2000 cfu/ml. Les *streptococci* fécaux sont présents en grandes quantités dans 76% des échantillons avec des concentrations supérieures à 1000 cfu/ml, ce qui témoigne d'un développement dans le système. Les coliformes totaux étaient présents dans de larges proportions avec en moyenne 470 cfu/ml.

Ces résultats confirment les données de tests en laboratoires où l'on a étudié la survie (valeur D) des bactéries fécales présentes dans l'urine. Dans les conditions rencontrées dans les cuves de stockage de l'urine, *E.coli* présente une valeur D inférieure à 1 jour. Les *streptococci* fécaux étaient réduits de  $10^6$  cfu/ml à moins de 10 cfu/ml en 5 mois de stockage, alors que *clostridia* ne montre pas de réduction avant 36 jours.

Ainsi, après les 6 mois de stockage habituellement appliqués pour l'urine séparée à la source, la qualité hygiénique de cette urine peut être considérée comme satisfaisante.

Mots-clés : hygiène, indicateurs fécaux, séparation urine source.

## 1. Introduction

By the re-use of wastewater or other separated parts of human wastes in agriculture, there is a possible risk for transmission of microbial contaminants to grazing cattle, to vectors, to surface and ground water and through standing crops to humans. The present laws and regulations for the re-use of human wastes vary between countries. In Sweden they are related to the national implementation of the EC Urban Wastewater Treatment Directive (EC, 1991). Also WHO has published guidelines for the safe use of wastewater (WHO, 1989). Some countries specify analyses of indicator bacteria, viruses and parasites while others put more effort into methods for treatment and restrictions for the use of wastewater products. According to Morsing (1994) there are four approaches to minimise the risk for contamination through sludge: (1) reduction of pathogens, (2) reduction of the

vector attraction (rats, flies etc), (3) soil treatment and (4) restrictions on cultivation methods and crops.

In several countries the use of untreated sludge in agriculture is not permissible. In Sweden it is permitted if the sludge is injected or worked into the soil within 24 hours after application. However, the main practises have been an anaerobic treatment of the sludge from wastewater treatment plants or, for single households, storage of the sludge for six months before re-use in agriculture. The latter has initially been the general rule also for the re-use of source separated human urine in Sweden.

A urine source separating sewage system is based on a toilet which has the bowl divided into two parts; the front part collects the urine and the rear one collects the faecal material. The urine is lead to a collection tank usually buried in the ground. When the tank is full the urine is transported to a farm where it is stored until used as a fertiliser, mainly for cereal crops. The faecal material is either mixed with the greywater and transported to a sewage treatment plant or collected separately and dry for composting.

Human urine is the largest contributor of nutrients to household wastewater. Approximately 80% of the nitrogen in wastewater and 60% of the phosphorus origins from urine if no phosphorus detergents are used (Sundberg, 1995). The total quantities of nutrients in human urine are significant when compared to the quantities of nutrients in mineral fertilisers used by agriculture. In Sweden, the yearly production of human urine equals 15-20% of the mineral fertiliser consumption 1993 (Jönsson *et al*, 1996), referring to nitrogen, phosphorus and potassium. Fertilising experiments have indicated that the fertilising effect of stored human urine is comparable to that of mineral fertilisers for wheat and barely (Kirchmann and Pettersson, 1995; Kvarmo, 1998). Furthermore, the concentrations of heavy metals in the urine solution are very low, for example it contained 3.2 mg cadmium/kg phosphorus (Jönsson *et al*, 1997). This can be compared to mineral fertilisers containing 26 mg Cd/kg P (Jönsson *et al*, 1997), and to sludge from Swedish sewage treatment plants containing an average 55 mg Cd/kg P (Swedish EPA, 1995).

Urine normally contains low amounts of transmissible microorganisms. It is therefore mainly the possible contamination of the urine by displaced faecal material that involves a risk. Due to the low amount of flush water used, a rather high concentration of microorganisms of faecal origin in the collection tank may occur even if minor amounts of faecal material enters the front part of the toilet bowl. We wanted to investigate the level of faecal contamination in urine collection tanks based on faecal indicator bacteria. Survival studies were performed in order to estimate how valid a risk assessment based on these indicator bacteria would be. From these results it also would be possible to determine optimal storage conditions for source separated human urine.



## 2. Methods

**Sampling - Urine collection tanks** Eleven different urine separating sewage systems located at eco-villages, one-family houses and others like schools were included in the study. Samples were collected at two occasions from 14 different urine collection tanks within these systems, both directly beneath the liquid surface and an additional sample including sedimented material from the bottom of the tank. The samples were transported cold to the laboratory where they were analysed the same day or within 18 hours.

**Urine storage tanks** Urine solution from one of the eco-villages was sampled after transportation to a storage tank. Samples were taken from the storage tank at three different occasions; after 17, 57 and 126 days of storage from four different levels; at the surface, in the middle of the liquid phase, five cm above the bottom of the tank and right at the bottom. The samples were transported cold to the laboratory and analysed the same day or within 18 hours.

**Analysis of physical and chemical parameters** - pH and temperature of the urine solution were measured during the sampling procedure using a portable pH-meter (Orion 250 A). The conductivity was measured simultaneously using a portable conductivity meter (Hanna Instruments 8733).

**Microbiological indicator analysis** - The samples were homogenized and diluted in tenfold steps. For each dilution three parallel agar plates were streaked with 0.1 mL of the suspension. Total coliforms were enumerated on mEndo Agar Les (Difco). The plates were incubated at  $35\pm 0.5^\circ\text{C}$  for  $44\pm 4$  hours and the number of shiny colonies was recorded after  $24\pm 4$  and  $44\pm 4$  hours of incubation. Colonies were confirmed by a negative oxidase test (Organon Technika). For quantification of *E. coli* mFC Agar (Difco) was used. The plates were incubated at  $44\pm 0.5^\circ\text{C}$  for  $24\pm 4$  hours and blue colonies counted thereafter. Confirmation was performed by fermentation of lactose and formation of indol from tryptophan (LTL5B, Oxoid). For faecal streptococci mEnterococcus Agar (Difco) was used. Typical colonies were counted after incubation at  $35\pm 0.5^\circ\text{C}$  for  $44\pm 4$  hours. Selected colonies were confirmed on Esculin plates that were incubated in  $44\pm 0.5^\circ\text{C}$  over night and by a negative catalase test. The vegetative cells of clostridia were inactivated by heating the samples to  $75\pm 5^\circ\text{C}$  for 15 minutes. The inactivated samples were diluted in tenfold steps and clostridia spores were analysed by the pour plate method with 1 mL of the diluted sample in Perfringens Agar Base (Oxoid). The plates were incubated anaerobically at  $37\pm 0.5^\circ\text{C}$  (BBL GasPak) for  $48\pm 3$  hours and the number of black colonies were recorded after  $24\pm 3$  and  $48\pm 3$  hours.

**Survival studies of indicator bacteria** - Survival studies of faecal indicator bacteria in source separated human urine were performed at two temperatures ( $4^\circ\text{C}$  and  $20^\circ\text{C}$ ), at three different dilutions (undiluted, 1:1 and 1:9), and at four different pH-values (4.5, 6.0, 8.9 and 10.5). Urine solution was collected from two

urine collection tanks at two different housing areas and mixed. The undiluted urine solution contained approximately 1-2 parts of urine per part flush water. Sterile water (Pharmacia & Upjohn) was used as diluent to prepare the 1:1 and 1:9 dilutions. pH of the collected urine solution was 8.9. To obtain pH 4.5 and 6.0 the urine solution was mixed with concentrated HAc. pH was adjusted to 10.5 by adding 1M NaOH. *Escherichia coli* and faecal streptococci were isolated from source separated human urine and added to the urine solutions to a final concentration of  $10^6$ /ml. *Clostridium perfringens* was isolated from faeces in a dry sewage system and added to a concentration of  $10^2$ /ml. Die-off of normally occurring faecal streptococci was also studied in urine solution with an initially high concentration of these bacteria at 4°C and 20°C. In this urine solution the proportion of urine and flush water was approximately 3:1. Enumeration of the indicator bacteria was performed as described above.

### 3. Results

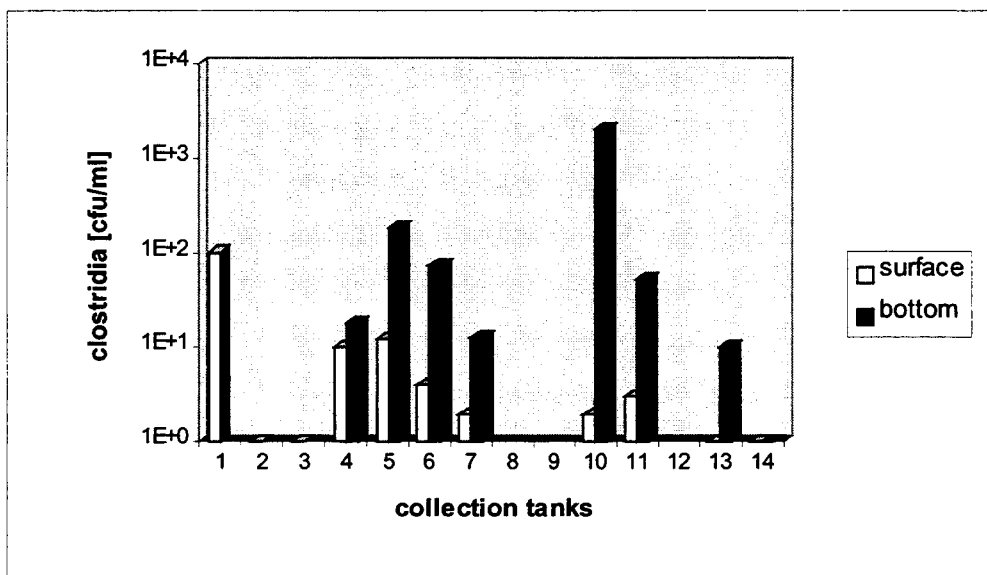

Figure 1

Concentrations of clostridia in samples from beneath the surface (surface) and from the bottom including sedimented material (bottom) from sampling round two. The values are expressed on a  $\log_{10}$  scale as cfu/ml urine solution.

**Collection tanks** - Among the indicator bacteria *E. coli* was found in the lowest concentration. In 84% of the samples the concentration was below the detection limit of 10 cfu/ml. Faecal streptococci were by far present in the highest concentrations; 76% of the samples having concentrations above 1000 cfu/ml.

Coliforms were found in varying amounts, calculated on the positive samples (55%) the mean value was 470 cfu/ml. Sulphite reducing clostridia were found in 76% of the samples with concentrations ranging from 1 to 2000 cfu/ml. All bacteria except coliforms were present in higher numbers in the bottom sediment samples than in the samples collected from beneath the surface.

Collection tanks that contained urine with high concentrations of faecal streptococci in the first round of sampling often showed similar results in the second round of sampling (figure 2). The corresponding was valid for low concentrations.

Table 1. Mean<sup>1</sup> and median concentrations (median concentrations in parenthesis) of faecal indicator bacteria in source separated human urine. n equals the number of samples included in the calculation of the mean value (samples with concentrations detection limit) and the number in parenthesis equals the total number of sampling results (all included in the calculation of the median value). Samples from beneath the surface (surface) and samples from the bottom of the collection tanks including sedimented material (bottom). Mean concentrations are listed with two significant numbers.

Samples	Coliforms <sup>2</sup> (cfu/ml)	E.coli <sup>2</sup> (cfu/ml)	Faecal <sup>3</sup> Streptococci cfu/ml	Clostridia <sup>4</sup> (cfu/ml)
Sampling round 1, surface	700 (100) n=8 (14)	58 (<10) n= 1 (14)	13000 (3135) n=11 (14)	140 (4) n=10 (14)
Sampling round 1, bottom	250 (<10) n=3 (7)	1200 (<10) n=1 (9)	200000 (7600) n=7 (9)	190 (86) n=8 (9)
Sampling round 2, surface	440 (22) n=6 (12)	5 (<10) (12)	16000 (2900) n=10 (12)	19 (2) n=7 (11)
Sampling round 2, bottom	230 (18) n=7 (11)	38 (<10) n=3 (9)	92000 (8000) n=12 (12)	340 (35) n=7 (8)
Total	470 (21) n=24 (44)	270 (<10) n=5 (44)	70000 (3000) n=40 (47)	340 (11) n=32 (42)

<sup>1</sup>Samples with concentrations below the detection limit are not included in the calculation of the mean values.

<sup>2</sup>The detection limit was 10 cfu/ml.

<sup>3</sup>The detection limit was 100 cfu/ml.

<sup>4</sup>The detection limit was 1 cfu/ml.

<sup>5</sup>All samples had concentrations below the detection limit.

**Physical and chemical analysis** - pH-values were generally around nine with a low of 8.30 and a high of 9.30. The temperature varied between 2.6°C and 18.5°C with a mean of 14.6°C and 8.0°C during the first and second round of sampling, respectively. The conductivity which can be seen as an indicator of the dilution varied between 1.76 mS/cm and 53.3 mS/cm with a total mean of 24.5 mS/cm. No correlation could be found between concentrations of indicator bacteria and pH, temperature or conductivity.

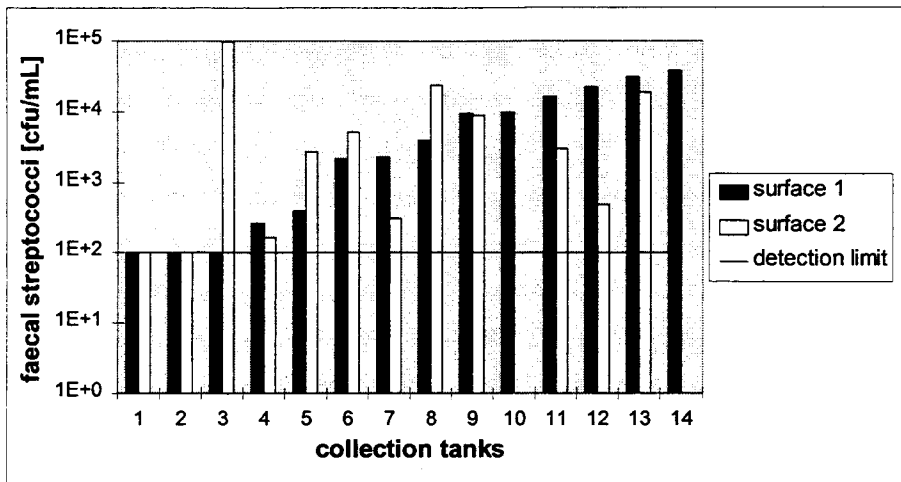

Figure 2

Concentrations of faecal streptococci in samples from beneath the surface in sampling round one and two. The values are expressed on a  $\log_{10}$  scale as cfu/ml urine solution.

**Storage tanks** - After four months (126 days) of storage, concentrations of all indicator bacteria except clostridia were below their detection limit of 10 cfu/ml. *E. coli* was not found in the collection tank (day 0) and not in the storage tank either. The amounts of bacteria were generally higher at the bottom in the storage tank as was the case in the collection tanks. For faecal streptococci and coliforms concentrations were higher at the surface than in the middle and close to the bottom.

	Storage days	Surface (cfu/ml)	Middle (cfu/ml)	5 cm above bottom (cfu/ml)	Bottom (cfu/ml)
Coliforms	0	250	82	<10	300
	17	<10	<10	<10	<10
	57	<10	<10	<10	<10
	126	<10	<10	<10	<10
Faecal streptococci	0	2400	1600	610	9500
	17	690	600	550	1600
	57	<10	<10	<10	110
	126	<10	<10	<10	<10
Clostridia	0	64	68	97	610
	17	140	130	110	240
	57	73	88	110	550
	126	15	59	88	290
<i>E. coli</i>	< 10 cfu/ml at every analysis.				

Table 2.

Concentrations of faecal indicator bacteria in source separated human urine during storage. Concentrations are listed with two significant numbers. The detection limit was 1 cfu/ml for clostridia and 10 cfu/ml for the other organisms.

**Survival experiments** - *E. coli* had the fastest die-off in the urine solution among the bacteria studied. At all pH-values except at pH 6.0, *E. coli* had D-values below one day, i.e. a reduction from  $10^6$  cfu/mL to below the detection limit occurred within five days of incubation for all other samples. In the 1:9 dilution *E. coli* had approximately five times longer survival than in undiluted urine solution, both at incubation temperatures 4°C and 20°C. Faecal streptococci had a slower reduction than *E. coli* in the urine solution. In the pH experiment all faecal streptococci had died within 20 days except in the two samples with pH 6.0 and 8.9 that were kept at 4°C. In these samples approximately one  $\log_{10}$  reduction had occurred after 27 days of incubation. Temperature had a significant effect on survival. In the samples with initially high concentrations of faecal streptococci a reduction from  $10^6$  cfu/ml to  $<10$  cfu/ml was obtained after 25 days at 20°C and after 150 days at 4°C. *Clostridium perfringens* showed no reduction in any of the urine solutions during 36 days of incubation. Thus, no effect of pH, temperature or dilution on the survival of clostridia spores was noted.

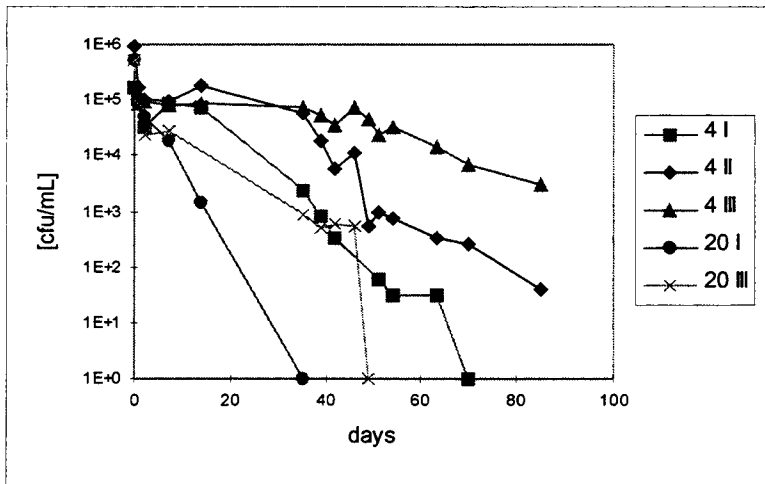

Figure 3.

Die-off of faecal streptococci in source separated human urine at different dilutions (I=undiluted, II=1:1, III=1:9) at 4°C (4) and 20°C (20). The values are expressed on a  $\log_{10}$  scale as cfu/mL urine solution. (Also published in Jönsson et al, 1996.)

#### 4. Discussion

Source separated human urine is a liquid solution rich in plant available nutrients. It contains very low concentrations of heavy metals, especially compared to sludge. Also, it is the fraction of human excreta containing the lowest amounts of microorganisms. Thus, by separating urine from other household wastes there is much to gain with regards to recycling nutrients to agriculture, eutrophication, water

saving and hygiene. Urine separation has been suggested as one part of a sustainable future in Sweden and about 3000 source separating toilets have been installed so far. However, it is inevitable that some contamination of the urine through mixing in of faecal material occurs and due to the low amounts of flush water used for the urine, concentrations of faecal bacteria might be as high as in untreated wastewater. Therefore a storage period of six months has been recommended before the urine is used as a fertiliser. If this period is reasonable depends on the initial level of faecal contamination as well as on the possibilities for various microorganisms to survive in the urine solution.

As has been reported before (Höglund *et al*, 1998) the different faecal indicator bacteria were present in various amounts. *E. coli* was seldom found, thus indicating no faecal contamination whereas faecal streptococci most often was found in high numbers indicating a significant faecal contamination. However, the concentration of faecal streptococci was in some collection tanks as high as  $10^6$  cfu/mL, which would correspond to 100% faeces (Geldreich, 1978). This indicates that there is a possible growth within the pipes leading from the toilets to the collection tank.

The higher concentrations found in samples from the bottom of the collection and storage tanks are explained by bacteria adsorbing to particles that sediment. Also the higher concentrations right at the surface in the storage tank can be explained by adsorption. Here bacteria bind to hydrophobic particles (Kjelleberg and Stenström, 1980). The variation in concentration of bacteria with depth illustrates the importance to collect representative samples. A calculated risk in this case would be underestimated if the bottom sediment was not included, and the other way around.

Many times concentration of *E. coli* is used as a single parameter for judging if hygienisation has occurred. In systems like this it is important to analyse several different indicator organisms rather than a single indicator bacteria. If only enumerating *E. coli* the hygienic quality of the urine solution would be considered as satisfactory without storage, whereas if enumerating clostridia the opposite would be the case.

The fast die-off of *E. coli* in human urine explains the above and further implies that this organism is useless when estimating the faecal contamination of the urine. Clostridia, which shows no reduction in urine, could possibly be used to calculate the degree of contamination. However, as previously discussed (Höglund *et al*, 1998) clostridia is not alone reliable as a faecal indicator. The frequency in human faeces is only 13-35% (Geldreich, 1978) and the spore can be found in various environments as well. The high concentrations of faecal streptococci and their slow reduction imply that they could be valuable as an indicator for sufficient storage.

Some of the urine separating sewage systems investigated were included in a previous study (Olsson, 1995). The systems having high concentrations of faecal streptococci in the presented study usually had high concentrations in the previous

as well. As shown in figure 2 the concentrations of faecal streptococci also correlated between sampling occasions within systems. Families could have their own strains of faecal streptococci more adapted to this environment or depending on the feature of the system, including piping, some systems are more likely to have higher concentrations of faecal bacteria present. Another reason could be that a sludge is formed at the initial use of the system. The special features of this sludge then determine future potentials for growth of different bacteria.

According to the commonly used faecal indicator bacteria the hygienic quality of the urine solution after storage would be equal to or better than recreational water guideline values. However, the true meaning of these indicator bacteria have been widely discussed and questioned. Are their survival coherent with the survival of pathogenic bacteria or not? In the case of shorter survival of indicator bacteria than of pathogens an estimation of the risk in a special case would be underestimated. There are known cases (Goldstein *et al*, 1996) where waterborne illnesses have been transmitted even though no indicator bacteria were present. This is important to recognise especially when evaluating the risk of newly recognised pathogens like the parasitic protozoa *Giardia* and *Cryptosporidium* known to be very resistant in the environment.

The results obtained from the survival experiments imply that a high temperature, a low dilution and a pH far from neutral shorten the survival of indicator bacteria. Survival of some pathogenic bacteria as well as other pathogens in urine has been studied (Jönsson *et al*, 1996, Höglund *et al*, 1998). Results indicate that the urine solution has a detrimental effect on microorganisms. So far no bacteria, excluding clostridia spores, seem to survive longer than faecal streptococci. Thus a storage period of six months would be sufficient. Data on the survival of *Cryptosporidium* in urine are currently being evaluated. It would also be valuable to study the behaviour of human viruses in urine. A salmonella phage showed no reduction during a 50-day period in urine, however, no coliphages have been found in urine collection tanks (Jönsson *et al*, 1996).

The inconsistency in the results from analysis of indicator organisms implicates that an alternative to the commonly used faecal indicator bacteria could be necessary for evaluating the function of complementary sewage systems and the quality of the product obtained. Faecal sterols have been suggested (Höglund *et al*, 1998; Sundin *et al*, in preparation) as a chemical indicator, suitable for estimating the faecal contamination of source separated urine. However, if sufficient storage is applied a control system might not be needed due to the germicidal effects of source separated urine as indicated by the above results.

## 5. Acknowledgement

These studies were financed by Swedish Farmers Foundation for Agricultural Research, Swedish Council for Building Research, VA-Forsk (Swedish Municipalities Sewage Research Program), National Board of Health and Welfare and the Swedish Environmental Protection Agency. We greatly acknowledge the skilful experiments done by Anna Olsson as part of her Master's Thesis in Agricultural Science.

## 6. References

EC (1991). *Council Directive of 21 May 1991 concerning urban waste-water treatment (91/271/EEC)*. Official journal NO. L 135, 30/05/1991 P. 0040-0052, The Council of the European Communities.

**Geldreich, E. E.** (1978). Bacterial populations and indicator concepts in feces, sewage, stormwater and solid wastes. In: Berg, G. (ed). *Indicators of viruses in water and food*. Ann Arbor Science Publishers, Inc.; Ann Arbor, USA.

**Goldstein, S. T., Juranek, D. D., Ravenholt, O., Hightower, A. W., Martin, D. G., Mesnik, J. L., Griffiths, S. D., Bryant, A. J., Reich, R. R. and Herwaldt, B. L.** (1996). Cryptosporidiosis: An Outbreak Associated with Drinking Water Despite State-of-the-Art Water Treatment. *Ann. Intern. Med.* 1996;124:459-468.

**Jönsson, H., Olsson, A., Stenström, T. A. and Dalhammar, G.** (1996). *Källsorterad humanurin i kretslopp – förstudie i tre delar* (Recycling source separated human urine - pilot study in three parts). Report 1996-03, VA-Forsk; Stockholm, Sweden. (In Swedish.)

**Jönsson, H., Stenström, T. A., Svensson, J. and Sundin, A.** (1997). Source separated urine - nutrient and heavy metal content, water saving and faecal contamination. *Wat. Sci. Tech.* Vol. 35, No. 9, pp. 145-152.

**Höglund, C., Stenström, T. A., Jönsson, H. and Sundin, A.** (1998). Evaluation of faecal contamination and microbial die-off in urine separating sewage systems. Accepted for Water Quality International '98 (*Wat. Sci. Tech.*).

**Kirchmann, H. and Pettersson, S.** (1995). Human urine - Chemical composition and fertilizer use efficiency. *Fertilizer Research*, 40:149-154.

**Kjelleberg, S. and Stenström, T. A.** (1980). Lipid surface films: Interaction of bacteria with free fatty acids and phospholipids at the air/water interface. *J. Gen. Microbiol.* 166:417-423.



**Kvarmo, P.** (1998). *Humanurin som kvävegödselmedel till stråsäd* (Human urine as a nitrogen fertilizer to cereals). Report 107, Department of Soil Science, Swedish University of Agricultural Sciences, Uppsala, Sweden. (In Swedish.)

**Olsson, A.** (1995). *Källsorterad humanurin - förekomst och överlevnad av fekala mikroorganismer samt kemisk sammansättning* (Source separated human urine - Occurrence and survival of faecal microorganisms and chemical composition). Report 208, Department of Agricultural Engineering, Swedish University of Agricultural Sciences, Uppsala, Sweden. (In Swedish.)

**Morsing, M.** (1994). *The Use of Sludge in Forestry and Agriculture. A Comparison of the Legislation in Different Countries*. Forskningsserien no. 5-1994, Danish Forest and Landscape Research Institute, Lyngby, Denmark.

**Sundberg, K.** (1995). *Vad innehåller avlopp från hushåll?* (What does household wastewater contain?). Report 4425, Swedish Environmental Protection Agency, Stockholm, Sweden. (In Swedish.)

**Stenström, T. A.** (1996). *Sjukdomsframkallande mikroorganismer i avloppssystem* (Pathogenic microorganisms in sewage systems). Report 4683, Swedish Environmental Protection Agency and National Board of Health and Welfare, Stockholm, Sweden. (In Swedish.)

**Swedish EPA** (1995). *Stora avloppsreningsverk - slam & avloppsvatten, aktuella förhållanden 1993* (Major sewage plants - sludge & wastewater, present conditions 1993). Report 4423, Swedish Environmental Protection Agency, Stockholm, Sweden. (In Swedish.)

**WHO** (1989). *Guidelines for the safe use of wastewater and excreta in agriculture and aquaculture*. WHO, Geneva, Schweiz.

# Inactivation of viral and bacterial pathogens in large scale slurry treatment plants

*Inactivation des virus et bactéries pathogènes  
dans les unités industrielles de traitement du lisier.*

**MARTENS, W., FINK, A., PHILIPP, W., WEBER, A., WINTER, D. and BÖHM, R.**  
University of Hohenheim, Institute for Environmental and Animal Hygiene,  
D-70593 Stuttgart. Germany.

## **Abstract**

*Slurry from farm animals can be contaminated with obligatory or facultatively pathogenic germs. Due to the concentration process in animal production in the Federal Republic of Germany, a regional surplus of animal slurry must be expected. Therefore, epidemiological risks and risks for environmental hygiene cannot be excluded if the slurry remains untreated.*

*In an extensive investigation program, six different slurry treatment plants were investigated comparatively with regard to the occurrence and survival of indigenous fecal bacteria and artificially added pathogens like bacteria and viruses. The tenacity of the artificially added microorganisms, bacteria and viruses (esp. Salmonellae and fecal streptococci, Aujeszky-, ECBO-, bov. Parvo- and equ. Rhino-virus) was investigated comparatively with "germ-carrier" methods, which were developed for bacterial and viral tenacity studies under practical field conditions.*

*Results show that under ordinary conditions thermophilic aerobic and anaerobic treatment guarantees a probable hygienisation of the process end product, but that the nominal working temperature which is necessary for sufficient hygienisation is not attained by all of the thermophilic plants. The mesophilic anaerobic processes, although microbicidal in principle, remain uncertain and demand an individual risk assessment for the individual case or an additional hygienisation step before or after anaerobic treatment.*

*Bovine Parvovirus proved to be the limiting and a most suitable test germ to investigate hygienisation effects of slurry treatment processes in which the microbicidal component is mainly based on temperature influence.*

**Keywords** : aerobic and anaerobic digestion, slurry hygienisation and pasteurisation, pathogen, virus and bacteria inactivation, germ carrier

## Résumé

Le lisier issu des exploitations d'élevage est contaminé par des bactéries pathogènes facultatives. A cause de la concentration animale importante en Allemagne, un surplus de lisier est constaté. Les risques épidémiologiques ne sont pas à exclure notamment si le lisier n'est pas traité.

Dans le cadre d'un vaste programme, six différentes unités de traitement du lisier ont été étudiées en comparant notamment la présence et survie de bactéries fécales endogènes ainsi que des pathogènes artificiels ajoutés tels que bactéries et virus.

Le devenir de ces bactéries artificielles ajoutées (espèces Salmonellae et Streptococci, Aujeszky, ECBO-bov, Parvo et equi. Rhino-virus) a été comparé avec les méthodes de germes traceurs qui ont été développés en conditions pratiques de plein champ.

Les résultats montrent qu'en conditions normales aérobies thermophiles ou anaérobies, le traitement permet une hygiénisation du produit final, mais que la température nécessaire pour cette hygiénisation n'est pas atteinte dans tous les procédés. Les procédés anaérobies thermophiles bien que bactéricides en principe, demeurent incertains et nécessitent une étape préalable d'hygiénisation.

Le parvovirus bovin s'est avéré le germe le plus intéressant pour des études sur les effets hygiénisants des procédés de traitement du lisier, au cours desquels l'effet bactéricide dépend notamment de la température.

Mots-clés : digestion aérobie et anaérobie, hygiénisation du lisier et pasteurisation, pathogènes, inactivation des bactéries et virus, germe test.

## 1. Introduction

Increasing concentration processes in animal husbandry in combination with intensive, spreadless farming lead to regionally increasing amounts of slurry. This results in an increased burden to the environment and pollution caused by chemical substances like ammonia gases (air) and salts (ground water) as well as microbiological pollutants (BÖHM, 1995). It comprises a hygienic risk too, as slurry may contain a great number of obligate or facultative pathogenic microorganisms which can be spread in the environment (STRAUCH, 1990) and which may remain infective for a long time in this material (STRAUCH and BALLARINI, 1994).

The German Ministry of Research and Technology therefore initiated an investigation program about technical treatment of slurry to transform it into environmentally harmless and usefull secondary products like composts and

ammonia fertilizers. In addition, aspects of substrate hygienisation were investigated in several technical pilot slurry treatment plants all over the country, most of them anaerobic slurry digestion process plants (biogas), one being an experimental aerobic thermophilic stabilisation (ATS) reactor.

Most investigations concerning tenacity of pathogens under different environmental conditions have been made by using bacteria. But in slurry, also several viral pathogens may occur (STRAUCH and BALLARINI, 1994) including those of notifiable animal epidemics as classical swine fever virus, Aujeszky disease virus and foot and mouth disease virus. In this context, the question if and how viral pathogens in slurry treatment plants are inactivated (e.g., during mesophilic and thermophilic anaerobic treatment) is of great interest, as is the question if there exist correlations between the inactivation of bacteriological and viral pathogens by anaerobic treatment.

Since it is not admissible to perform investigations in real plants using agents of notifiable diseases, representative germs of an environmentally harmless character had to be used instead. These viruses were brought into the treatment processes of the plants by means of a filter sandwich germ-carrier technique developed (TRAUB et al., 1986, 1988) and modified (WINTER et al., 1995) for viral tenacity studies. The germ carrier technique of RAPP (1995) was used for bacterial test germs. Both of these techniques avoid the contamination of the investigated substrates but allow a direct interaction between process parameters as pH-value, redox potential, enzymes etc. with the exposed microorganisms.

## **2. Material and methods:**

Viruses und cell cultures : Aujeszky-virus (vaccine strain) was cultivated and detected in PK 15 cells (porcine kidney), ECBO virus (Enteric Cytopathogenic Bovine Orphan), strain LCR 4, in MDBK cells (Madin and Darby bovine kidney). ERV 1-Virus (Equine Rhinovirus), in cell line RK13 (Rabbit kidney). BPV (Bovine Parvovirus), strain Haden, in primary BEL cells (bovine embryonic lung).

Bacteria : *Streptococcus faecium* (ATCC 6057) as well as native fecal streptococci were detected and counted by the MPN-method with first cultivation in AD (azide glucose) bouillon (24 h) and plating out on KAA-Agar (Kanamycin, Äsculin , azide). *Salmonella senftenberg* W 775 and *S. enteritidis* were first cultivated in peptone water (24h/37°C) followed by Rappaport medium (24h/43°C) and then plated out on BPLA- and XLD-Agar (24h/37 °C).

Virological germ carrier technique : The carrier cases are 25 mm membrane filter carriers (Sartorius, Göttingen, Germany) whose inlet and outlet openings are widened to 15 mm diameter. In a carrier a membrane is loaded (ZETA PLUS-Virosorb1- MDS, AMF, Cuno Div., Meriden, Connecticut.) with a specified amount

of virus (adsorbed). Towards the inlet and outlet this membrane is covered with two polycarbonate membranes - membrane sandwich - with a defined pore size of 10 nm diameter (Infiltec, Speyer, Germany). Due to the small size no virus can pass through to contaminate the surroundings, whereas all low molecular components of the surrounding may pass the membranes which means inactivating or stabilising influences from the surrounding media may effect the encovered test virus (pH value, NH<sub>3</sub>, temperature etc.).

For tenacity studies several germ carriers were brought into the medium (or process) of question and removed successively in specified time intervals. By determining of the remaining infectivity (TCID<sub>50</sub>, tissue culture infectious dose) by titration on permissive cell cultures the virus inactivation kinetics in the individual process were determined.

Bacterial germ carrier technique : The bacterial germ carrier consists of a hollow synthetic cylinder covered on both sides with semipermeable polycarbonate membranes (pore size 0,2 µm) which are fixed with two tight screwable rings (RAPP, 1995). It is filled with a 1 to 1 mixture of slurry and the bacterial suspension. Tenacity studies are carried out similar to those with virological germ carriers and the remaining infectivity of the bacteria after exposure is determined by titration according to the "most probable number" method as colony forming units/ml (CFU/ml).

### 3. Results

In both thermophilic aerobic (Fig. 3) and anaerobic (Fig. 1) processes, at temperatures of about 55 °C, logarithmic reduction (log. red.) of the tested Picorna viruses (ECBO-Virus resp. ERV) took place within a few hours. Nearly in parallel, even a little faster, all tested Salmonellae were inactivated. As expected, fecal streptococci proved to be more thermoresistant, but within 24 hours a titer reduction of more than 4 powers of ten (p.o.t.) took place in the native germs of the substrate as well as in those added artificially to the process. The Parvo virus proved to be the most stable, its titer was reduced under 3,5 (p.o.t.) sometimes, and in all cases it remained detectable up to the test ends.

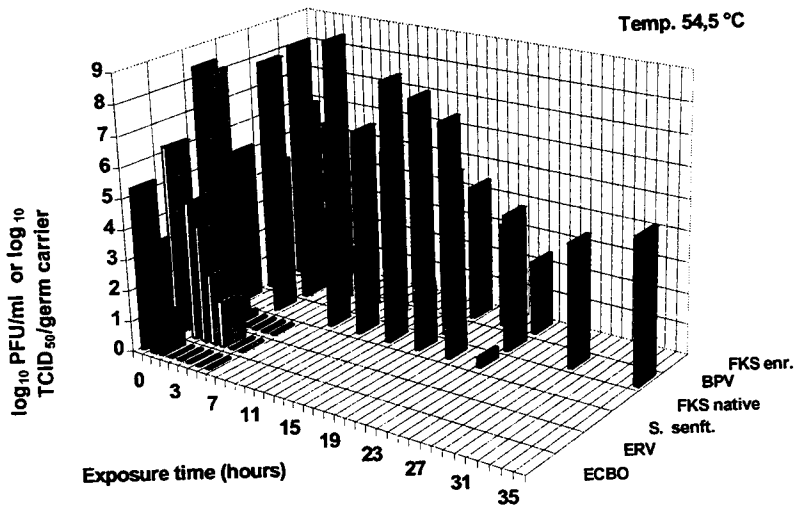

Figure 1: Reduction of different test germs in a thermophilic biogas plant (cattle slurry, 54,5°C; FKS: Fecal streptococci; BPV: Bovine Parvovirus; S. senft.: Salmonella senftenberg; ERV: Equine Rhinovirus; ECBO: Bovine Enterovirus)

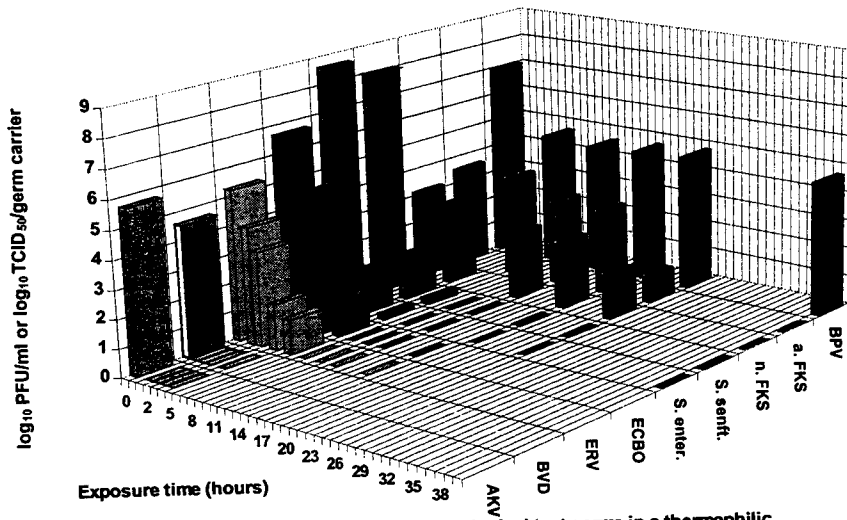
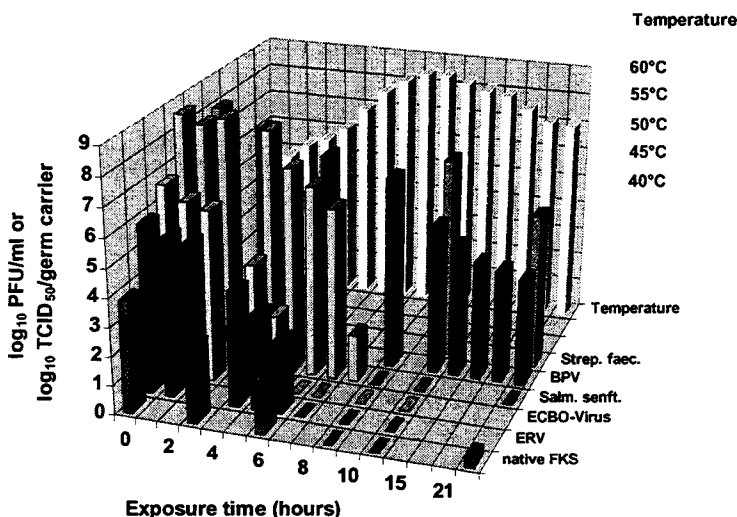

Figure 2: Inactivation of bacterial and virological test germs in a thermophilic anaerobic fermenter (cattle slurry, about 46°C).

**Figure 3: Inactivation of test germs in an aerobic thermophilic reactor (cattle slurry)**



In one anaerobic plant, also indicated as thermophilic and apparently proven as such by temperatures of about 55 °C in the reactor outlet, a remarkably delayed inactivation of the mentioned bacteria and viruses took place (Fig 2.), although the Aujeszky virus and BVDV as a model for classical swine fever virus, which were also tested, were quickly inactivated. Accurate temperature measuring in the middle of the reactor, where the germ carrier were placed, showed only process temperatures of about 46 °C in that region.

In most cases, anaerobic digestion at mesophilic temperatures lead to a remarkable titer reduction of all types of test germs, however in a time range of days and weeks. An example is given in Figure 4. The enveloped viruses tested could not be detected after one day only. A certain similarity of the inactivation kinetics of *S.senftenberg* and ECBO virus resp. ERV can be stated. In some cases a log. red. of more than 4 p.o.t. took place for those germs within two weeks, sometimes under the detection limits. Fecal streptococci and BPV however were reduced mostly by 1 to 2 p.o.t. only in this period of time and could be detected at the end of all tests. The inactivation kinetics of both germs took place nearly in parallel in most cases.

In some tests with reactor temperatures below 30 °C none of the test germs were inactivated. Even after periods of several weeks, even Salmonellae could be detected in nearly unchanged titer size.

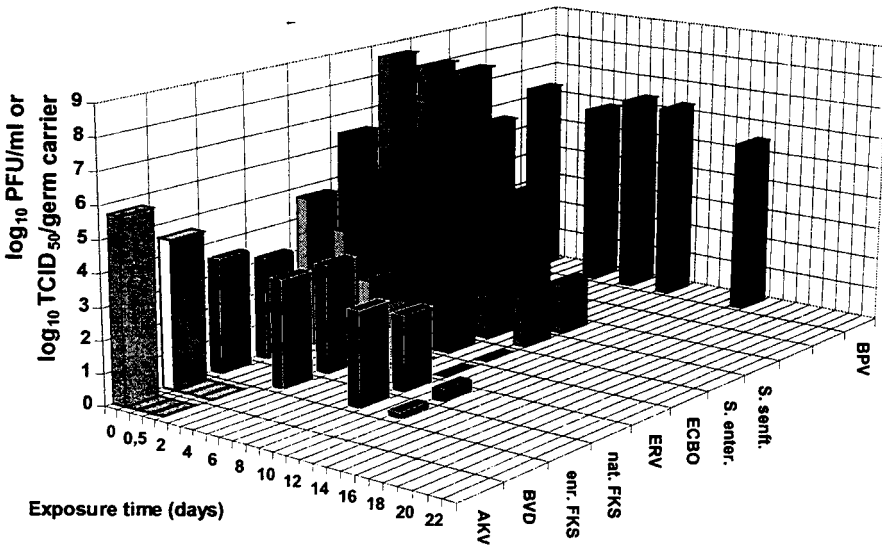

**Figure 4:** Inactivation of bacterial und virological test germs in a mesophilic anaerobic fermenter (cattle slurry, about 31°C).

**Figure 5:** Inactivation of test germs during the hygienisation step of a mesophilic slurry treatment plant (pre-heating, cattle slurry)

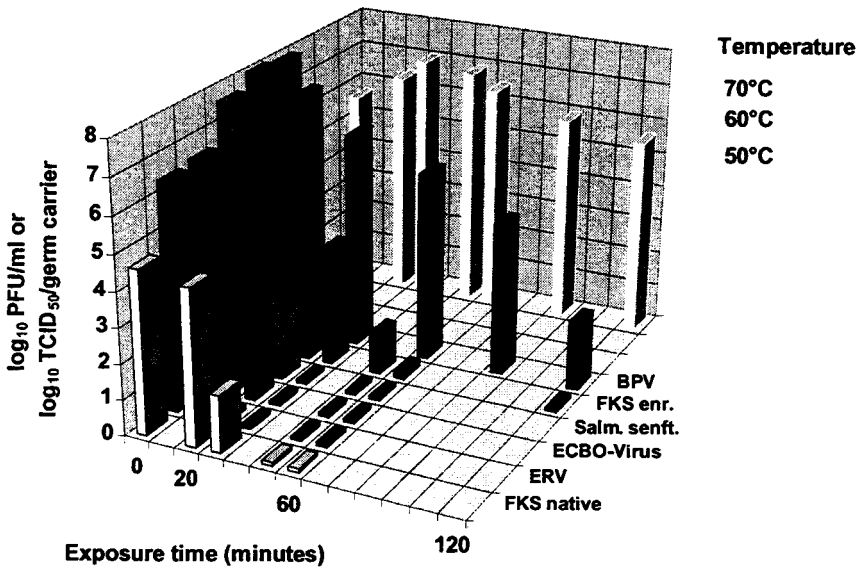



In the so-called cofermentation plants, in which slurry is digested together with other organic components as animal fat, biologic household wastes etc., the mesophilic anaerobic treatment processes in Germany mostly include a hygienisation step consisting of a pre-heating, in which the cosubstrates (not the slurry) are heated up to 70 °C for 1 hour, as it is recommended by the Federal Ministry of Agriculture. By that treatment nearly all tested microorganisms were completely inactivated or at least reduced over 4 p.o.t. (Fig. 5), as it is demanded for proving sufficiency in testing chemical disinfectants. Only BPV resisted and was inactivated over 3 to 3,5 p.o.t.

#### **4. Discussion**

In slurry a great number of pathogenic microorganisms may occur and remain infective for a long time (STRAUCH, 1990; STRAUCH und BALLARINI, 1994). For slurry treatment plants, where the end products are used for agricultural purposes, the demand should be that the substrate is sufficiently hygienized during treatment. Otherwise new infection cycles may be created and infection chains closed in the environment, especially in the cases of "cofermentation", because with the cosubstrates other pathogens from many different origins can be brought into the process.

Slurry treatment reactors are inter alia marked by two process characteristics. First, the technical retention time, which is the mean time the slurry stays in the reactor and is exposed to the process. It is an important characteristic to assess for example the efficiency of gas production. For assessment of sufficient hygienisation the second is of greater importance, the real reactor retention time. This is the period of time freshly added slurry (or cosubstrates) needs to leave the reactor and the process via the outlet. As pathogens existing in the substrate, although diluted, may leave the process by short cut streams, the knowledge of the real retention time is essential. Otherwise, even in the case of a microbicidal effect of a process and a theoretically sufficient technical retention time, sufficient hygienisation cannot be assured if the real retention time is too short to guarantee a sufficient exposure time of all reactor outlet material to the process. Under this point of view, the treatment processes must be divided into those with a batch operation mode for the reactors which guarantees a specific real retention time and those with continuous flow processes in which the real retention time is unknown and can only be roughly estimated.

Our studies proved microbicidal effects for both aerobic (ATS) and anaerobic slurry treatment processes under field conditions. These effects vary in a wide range depending on the process parameters. As shown before (HAAS et al., 1995; LUND et al., 1996; PESARO et al., 1995), for the assessment of sufficient thermophilic treatment, process temperature is one decisive element: the higher the temperature, the faster the inactivation of microorganisms.

In tests of chemical disinfectants according to the instructions of the German Veterinary Medical Association, a log. red. of 4 p.o.t. of the test germs gives sufficient effects (DVG, 1988). The results of our studies proved such reduction in all cases of properly operating thermophilic aerobic and anaerobic processes within a time of 24 hours for all test germs except BPV. That means that all really thermophilic plants strictly reduce the risk of pathogenic germs spreading through the end products, and in cases of a 24 h batch mode a sufficient hygienisation can be stated, whereas in continuous flow processes the retention time may not be long enough to exclude the passage of not inactivated pathogens. But up to now, this applies only to the fermentation of pure slurry, not necessarily to the end products of "cofermentation" plants. With cosubstrates like animal fat, meat, bone and bone tissue containing wastes etc., pathogens may be introduced into the process in a special form which may protect them against inactivating influences of the process and lead to a longer survival time. This question is the subject of actual further investigations.

Another result of our study showed that not every supposed thermophilic process is in real thermophilic, even if the reactor outlet temperatures reach 55 °C and its construction is of a known type. The real process depends on the individual case, comprising the reactor construction, the (unknown) streaming conditions of the reactor inroom, the process stability, the substrates etc. Hygienisation sufficiency cannot be judged from outside aspects or by theoretical process parameters, and not by data gained in laboratory investigations, because they may not be representative for the actual process. It's efficiency has to be evaluated for the specific case under real practical conditions, best by determining the real hygienisation effects with exposure of adequate test germs and determining their loss of infectivity.

Inactivation normally takes place also by mesophilic anaerobic treatment, but in a period of days or weeks, and a log. red. of 4 p.o.t. does not occur regularly, which means that the process is not sufficient to hygienise the substrate completely (see for ex. Fig. 4). Evaluation has to be done for each individual case, taking into account the technical substrate retention time in the process and, even more important, the real minimal retention time (risk of short-circuits). For cofermentation plants a pre-treatment of other animal wastes (fat and tissues) - the demand of a previous hygienisation of the co-substrates, as it is shown in figure 5 - is indispensable for the same reason.

Previous studies (HAAS et al., 1995; PESARO et al., 1995) showed that in anaerobic processes temperature is only one inactivating component among others, and our data proved that in mesophilic processes it is not of main importance, because the inactivation of the test germs occurs at temperatures that don't lead to inactivation in comparable laboratory tests. According to the microbicidal influences the effective sum of other components seems to determine the degree of inactivation. Such components are, e.g., the pH value, the redox potential and the NH<sub>3</sub> concentration. In our studies we did not succeed in ensuring

correlations between germ inactivation and such other factors up to now. To achieve this, complex and systematic research is necessary. However, this will be feasible only to a limited extent under conditions of a real working plant.

In our studies we also investigated possible correlations of inactivation kinetics between some bacteria and virus groups often used as test germs for tenacity studies in the environment. It could be shown that the inactivation kinetics of the tested *Salmonellae* in the investigated processes nearly correspond to those of the two picorna viruses used. Viruses of this group are known to be comparatively stable in the environment, especially against chemical influences - ECBO virus, for instance, is a limiting germ to test virucidal effects for disinfectants according to the regulations of the DVG (DVG, 1988). Our results allow the conclusion that inactivation studies by using sufficient amounts of *S.senftenberg W775* in anaerobic treatment plants, as may be demanded in Germany by law in the future, indicate the inactivation of Picorna viruses or other environmentally less stable viral pathogens which may occur in slurry.

However, this applies not to the Parvo viruses which proved to be limiting in other tenacity studies during anaerobic treatment (BØTNER, 1990; LUND et al., 1996; PESARO et al., 1995). In our studies BPV proved to be clearly more thermostable than fecal streptococci, whereas in mesophilic processes where inactivating effects may not predominately be ruled by thermic inactivation, both agents proved quite similar tenacity. But with rising temperature, as the results of thermophilic treatment plants and pre-hygenisation steps of some cofermentation plants show, fecal streptococci were inactivated faster than BPV. This is in accordance with LUND et al. (1996), who compared the tenacity of a bovine enteric virus, fecal streptococci and porcine parvo virus in anaerobic processes.

BPV - being easy to handle in a virological laboratory and environmentally save - might be a suitable test germ for hygenisation effects of treatment processes like thermophilic anaerobic digestion in which thermic influence is the main component of germ inactivation. The aim of it should not be a complete inactivation of this virus (because for farming animals this virus group is of no epidemiologic importance, except the porcine parvo virus) but by its log. red., statements could be made which are applicable to nearly all specific pathogens, esp. to the economically main important causes of animal epidemics that are much more instable against thermic influences than BPV. Future studies related to this topic are necessary and in preparation.

## 5. References

**BÖHM, R.** (1995) : Der Einfluß veränderter Strukturen der Nutztierhaltung auf die Umweltbelastung durch Abfall und Reststoffe aus der Tierproduktion. DTW Dtsch. Tierärztl. Wochenschr. 102:278-283

**BØTNER, A.** (1990) : Modelstudier vedrørende overlevelse af virus i gylle under traditionel opbevaring og under udrådning i biogasanlæg. Research report. State Veterinary Institute for Virus Research, Lindholm, Denmark, 74 pp.

**DEUTSCHE VETERINÄRMEDIZINISCHE GESELLSCHAFT e.V. (DVG)** (1988) : Richtlinien für die Prüfung chemischer Desinfektionsmittel in der Veterinärmedizin. 2. Auflage, DVG Giessen, Germany

**HAAS, B., R. AHL, R. BÖHM and D. STRAUCH** (1995) : Inactivation of Viruses in Liquid Manure. Rev. Sci. Tech. Off. Int. Epiz. 14 (2):435-445.

**LUND, B., V. F. JENSEN, P. HAVE und B. AHRING** (1996) : Inactivation of Virus during Anaerobic Digestion of Manure in Laboratory Scale Biogas Plants. Antonie van Leuwenhook 69:25-31

**PESARO, F. et al.** (1995) : In Situ Inactivation of Animal Viruses and a Coliphage in Non-aerated Liquid and Semiliquid Animal Wastes. Appl. Environ. Microbiol. 61:92-97.

**RAPP, A.** (1995) : Hygienisch-mikrobiologische Untersuchungen zum Verhalten von ausgewählten Bakterien und Viren während der längerfristigen Speicherung von Flüssigmist in Güllegemeinschaftsanlagen. Thesis, University of Hohenheim

**STRAUCH, D.** (1990) : Survival of Pathogenic Microorganisms and Parasites in Excreta, Manure and Sewage Sludge. Rev. Sci. Tech. Off. Int. Epiz. 10: 813 -846.

**STRAUCH, D. und G. BALLARINI** (1994) : Hygienic Aspects of the Production and Agricultural Use of Animal Wastes. J. Vet. Med. B. 41:176-228

**TRAUB, F., et al.** (1986) : Method of Determining Virus Inactivation during Sludge Treatment Processes. Appl. Environ. Microbiol. 52:498-503

**TRAUB, F., et al.** (1988) : Inaktivierung von Viren bei der Klärschlammbehandlung. Schr.- Reihe Verein WaBoLu, Gustav Fischer Verlag, Stuttgart 78:107-119.

**WINTER, D., W. MARTENS, A. WEBER und R. BÖHM** (1995) : Inaktivierungskinetik von ECBO-Virus in verschiedenen Prozeßstufen moderner Gülleaufarbeitungsanlagen : Untersuchungen mit der Filtersandwich-Keimträgermethode. 2. Symposium on Desinfection, Disinsection, Deratization in Animal Health and Environ. Protection. Umag, Croatia, Sept. 28-30, 1995. ISBN 953-96576-0 1



## Handling of manure in deep-litter pig houses.

*Manutention des déjections dans les bâtiments porcins  
sur litière biomaitrisée.*

**Esa Klemola and Sirkka Malkki**

TTS-Institute, Work Efficiency Institute.

P.O. Box 13. FIN-05201. Rajamaki. FINLAND

E-mail : Smalkki@ns.tts.fi

### **Abstract**

*Pigs are kept on a thick layer of sawdust bedding in deep-litter pig houses. The manure is mechanically mixed with the sawdust every week so that it starts composting. Furthermore, the composting process produces heat which then evaporates extra moisture. Pig houses are emptied once a year; the precomposted manure is heaped in a field to after-ripen. New litter is spread on the floor and no separate storehouse for faeces and urine is needed, since the litter bedding acts as a repository.*

*A well-functioning deep-litter system entails approximately the same amount of work as does the removal of manure and cleaning of pens in liquid-manure pig houses particularly when the litter is mixed with a cultivator or a screw-mixer. Moving pigs and opening gates take nearly half of the actual working time. Deep-litter bedding is relatively quick to muck out with a loader.*

*Unlike the liquid-manure method, where the workload is evenly distributed over the days of the week and the handling of manure is relatively simple, the mixing of the litter requires peaks of work in the week. Despite regular mixing, the deep-litter bedding sometimes fails to compost; this happens especially under subzero temperatures and if there are too many pigs in relation to the floor area, or if ventilation and extra heating are inadequate. Replacing the litter partly or completely furthers the composting process, but also considerably increases the workload and litter costs.*

*Some pig farmers have found the tending of the deep-litter bedding so laborious and unpleasant that they have replaced it with liquid-manure or solid-manure systems. In order to achieve the composting process of deep-litter bedding, the number of pigs should often be decreased, which would naturally reduce the profitability of each pig house. The deep-litter bedding system has worked well for sows, for which deep-litter housing is still being built in Finland.*

## Résumé

En bâtiment sur litière profonde, les porcs sont placés sur une couche épaisse de litière de sciure. Les déjections sont mélangées à la sciure chaque semaine ce qui permet le démarrage du processus de compostage. Ce même processus dégage de la chaleur qui ainsi évapore l'humidité en excès. Les bâtiments sont vidés une fois l'an. Le fumier précomposté est alors placé en tas en bout de champ. Une nouvelle litière est épandue sur le revêtement.

Un bon fonctionnement de ce système sur litière nécessite la même quantité de travail que l'évacuation des déjections et le nettoyage des salles en système lisier, notamment lorsque la litière est mélangée à l'aide d'un cultivateur.

Cependant, contrairement au système lisier pour lequel l'investissement en travail est continu au cours de la journée, le mélange de la litière nécessite des pics de travail au cours de la semaine. Au delà du mélange régulier des déjections et de la sciure, la litière ne composte pas. Cela se produit lorsque les températures sont basses et le nombre d'animaux trop élevé par rapport à la surface au sol ; ou bien si la ventilation et le chauffage ne sont pas bien adaptés.

Quelques éleveurs de porcs ont trouvé ce système de gestion trop laborieux et désagréable et sont alors revenus au système de gestion avec lisier ou avec des systèmes sur paille. Afin de permettre le déroulement du compostage, le nombre d'animaux par unité surface doit être réduit, ce qui diminue d'autant la rentabilité des bâtiments. Ce système de litière biomaitrisée est bien adapté dans les bâtiments avec truies qui sont encore construits en Finlande.

## 1. Introduction

Deep-litter pig houses rapidly became popular in Finland in the mid-1990s. Today they are being used in approximately 150 farms which mainly specialise in finishing pigs and sows. Low construction costs and the possibility to put the pig house quickly into productive use increased the popularity of this method. The deep-litter method was also considered safe for both animals and the environment (Klemola 1998)

In deep-litter pig houses the pigs are kept in large pens (usually over 50 pigs per pen) on litter bedding 50–60 centimetres deep. Manure is mixed with the litter which then starts composting. The composting process produces heat which, together with efficient ventilation and heating, evaporates extra moisture. The volume of manure also reduces considerably.

Sawdust is the most common sort of litter used in deep-litter pig houses (Ketola 1994, Kolhi 1995, Laine 1997), and it is replaced once a year. The precomposted manure is heaped in fields to ferment further and later to be spread. No separate storehouse for faeces and urine is needed, since the litter bedding acts as a repository (Anon. 1992). In the future, however, storehouses for manure may become obligatory, when new directions for the handling of manure become effective in Finland.

The key issue of the deep-litter method is the functionality of the compost, which has an impact not only on the pigs' welfare but also on the amount of work required and production costs. Under the weight of the pigs the sawdust becomes so packed that the compost fails to receive enough oxygen, which then inhibits its composting. Excessive moisture fills the air pores in the sawdust and the litter becomes saturated. These problems occur particularly during subzero temperatures when the evaporation of moisture is inadequate.

The removal of moisture from the litter and the indoor atmosphere of the pig houses requires more efficient ventilation and additional heating than in conventional pig houses (Suomi 1995, Pyykkönen 1996). Furthermore, the litter area for each pig has to be adequate. According to present building recommendations and the energy calculations made by Puumala and Pyykkönen (1997), the adequate area per pig in deep-litter houses is 1.5 m<sup>2</sup>, whereas in pig houses with liquid-manure systems the corresponding area is 0.8 m<sup>2</sup> (Kotkansaari and Väänänen 1996).

In order to create optimum conditions for the composting of the litter, the bedding has to be mixed every week with a cultivator, a tractor rotavator, or special machinery. During the mixing, wet sawdust is often moved from one place to another to equalise the moisture content of the bedding. When necessary, wet sawdust can also be replaced with fresh, dry litter in places where the pigs usually defecate.

Knowledge on the impact of the deep-litter bedding on the workload in pig houses is rather contradictory. Approximately only 20 per cent of those who answered the questionnaire compiled by Kolhi (1995) thought that the use of deep-litter bedding increased their workload. Furthermore, the increased workload was not considered a serious disadvantage. The study conducted by Pyykkönen (1994) also gave a fairly optimistic outlook of the amount of work required by the deep-litter method. In a number of articles, however, the method was criticised for the excessive workload it demanded; the mixing of the deep-litter bedding was also regarded as laborious and unpleasant. In Laine's study (1997), 27 per cent of the respondents considered the deep-litter method easier than the conventional one, whereas 50 per cent thought it more laborious, and the rest were unable to estimate the workload or considered it equal in both methods.



The TTS-Institute conducted a work study on the labour consumption required by the mixing of deep-litter bedding in pig houses and other influencing factors. The quality of the work done by machines in the mixing of the litter was also studied as well as the impact of different types of buildings on the tending work.

## **2. Materials and methods**

During 1996–97, altogether fourteen work studies were carried out in pig houses to calculate the working hours required by cultivators, screw-mixers, tractor loader, and loading shovel in the mixing of litter. The most commonly used machines in the mixing of litter are the cultivator and tractor loader. The screw-mixer was developed specifically for the mixing of litter (Ketola 1994, Kolhi 1995, Jussila and Penttilä 1996, Penttilä 1995). The time used in replacing litter with a frontloader was also defined.

The norms for each machine used in the mixing and replacing were based on the work study. These were calculated on the assumption that there are ten pens of fifty pigs each and the litter area is 750 m<sup>2</sup> (=1.5 m<sup>2</sup> per pig). The norm represents labour consumption or output. It includes the various phases of work (e.g. preparing for the work and actual work), the disrupting factors in the work, the recovery period which depends on how strenuous the work was, and the amount of working time as a proportion of the regular daily work routine (Anon. 1988).

## **3. Results and discussion**

According to the work study, mixing the litter with a cultivator or with a screw-mixer took more or less the same amount of time (Table 1). With a cultivator, a clearly longer period of time was spent on turning and reversing the machine in the pen. If it were possible to have driven through the pig house, there would be less unnecessary driving. A screw-mixer worked better than a cultivator, since it could dig deeper for clean sawdust. Mixing was considerably slower with various loaders and particularly a loading shovel than with a cultivator or screw-mixer. However, loaders could be used to move wet litter from one place to another and this way equalise the moisture content of the bedding.

The size of a pig house or compartment contributed to the labour consumption. For a pig house which was divided into several small compartments, the time used in mixing the litter could double compared with typical deep-litter pig houses. In the latter case, the pens were arranged in a row so that the whole area could be mixed in two phases.

Pig house	Labour consumption min./100m <sup>2</sup>	Work time min./500 pigs
Mixing the litter, one person		
. with a cultivator	8.2	62
. with a screw-mixer	10.1	76
. with a tractor loader	18.4	138
. with a loading shovel	39.3	295
Opening gates and moving pigs, two persons.	15.6	117
Preparations (manual), two persons	2.2	17

*Table 1*

*The norms of mixing the litter in pig houses (500 pigs, 10 pens, litter area 750 m<sup>2</sup>) and the working time of two people in a pig house for 500 pigs.*

During the mixing of litter, nearly half of the working time was spent opening gates and moving the pigs. This could be done more quickly, if the gates were lighter and easier to handle. Larger pens failed to make the work any faster, since moving the pigs in a large pen was more laborious. In addition, the more pigs there are, the more the rate of their growth varies, and they have to be sold in several lots. Even though tail-biting and other aggressive forms of behaviour are rare in deep-litter pig houses, they may become a problem in larger pens (Penttilä 1995, Pyykkönen 1995).

Mixing litter in a pig house for 500 pigs took 3.3–7.2 hours, depending on the machinery used. Correspondingly, the annual working time per pig was approximately 20 minutes, when the litter was mixed once a week with a cultivator or screw-mixer. Mixing the litter with a loading shovel took approximately 40 minutes per pig, if there were two persons opening the gates and one person doing the mixing. If the whole procedure were regarded as a task for two persons, as it usually was, the amount of time used would be somewhat higher (Table 2).

Mixing machine	Annual labour consumption		
	min./pig	min./pig space	min./pig space (2 pers.)
Cultivator	6.2	19	25
Screw-mixer	6.7	20	27
Tractor loader	8.7	26	39
Loading shovel	13.7	41	69

*Table 2*

*Labour consumption when litter was mixed once a week and there were three lots of pigs per year*

The sawdust bedding was replaced completely after three lots. If the bedding was very wet, it had to be replaced more often. According to the results of the study, the various working phases in the replacement of the litter were relatively easy and quick to accomplish. Loading the litter manure was fast. However, cleaning the edges manually somewhat increased the labour consumption. Replacing the litter took only 3.6 minutes per pig, if a quarter of the litter was replaced twice before the complete replacement. This way replacing the litter took only 1.2 minutes per pig, when the litter was replaced after three lots (Table 3).

Mixing machine	Time according to norm		
	min./100m <sup>2</sup>	min./pig space	min./pig
Removal of old litter and cleaning of the pen	102	1.5	0.51
Taking new litter in	69	1.0	0.34
Partial replacement of litter (25%)	34	1.0	0.34

*Table 3  
Labour consumption when the litter was changed with a fronloader.  
Three lots per year per pig space.*

Unlike liquid manure, litter manure usually had to be handled twice: first it was heaped in the field and only later spread where needed, whereas liquid manure was taken straight from the storage to the field. The amount of manure was considerably larger in the liquid-manure method, since it contained a lot of liquid, but the workload of driving and spreading the manure was more or less the same for both methods.

When all the work in the pig house and the driving of the manure were added, the overall labour consumption in the deep-litter pig house amounted to 28 minutes per pig, if the litter was mixed with a cultivator or screw-mixer, and 37 minutes per pig when using a loading shovel. The size of the pig house and the mixing and replacing frequency was assumed to be the same as in the previous calculations. In the liquid-manure pig house the overall labour consumption was 31 minutes per pig as calculated according to agricultural norms (Anon. 1988).

For the liquid-manure method, the removal of manure occurred efficiently and the workload was evenly distributed, except for the spreading of manure on the field. In contrast, the mixing of the deep-litter bedding caused weekly work peaks. The workload was further increased as a precaution against failure to compost. The mixing of the litter entailed laborious working phases under poor conditions, which was why tending the deep-litter pig house was often considered unpleasant and more laborious than it actually was.

The deep-litter method -has been considered safe for both animals and the environment. Nitrogen losses may be greater than with the liquid-manure method, since lots of nitrogen evaporates as ammonia and nitrous oxide (N<sub>2</sub>O) from the compost (Groenstein ref. Kaufmann et al. 1997). Nutrients are also easily washed away, if insufficiently composted manure is piled uncovered in the field, as is often done today.

#### **4. Conclusion**

The tending of a functional deep-litter bedding required more or less the same amount of work as the removal of liquid-manure and the cleaning of pens in conventional pig houses. In practice, however, the mixing intervals in the deep-litter pig houses had to be shortened or wet sawdust replaced, if the composting process failed to occur. This increased both the workload and litter costs considerably.

In the deep-litter method, the litter area had to be 1.5 m<sup>2</sup> per pig so that extra moisture could be evaporated by the heat produced by the composting process. Ventilation and additional heating also had to be more efficient than in conventional pig houses. The function of the compost could be improved by mixing the litter regularly. However, problems caused by the design of the pig house or due to too many pigs could not be solved by mixing deep litter.

Farmers often regarded the tending of the deep-litter bedding as laborious and unpleasant, particularly if handling the gates and moving the pigs were not considered when designing and building the pig house. Problems with the function and handling of deep-litter bedding have decreased the popularity of this method to the extent that some farmers have already replaced the deep-litter with a conventional pig house using liquid manure system. For sows, however, the deep-litter bedding has worked due to correct number of pigs and regular mixing.

#### **5. References**

- ANON.** 1988. Maatalouden työnormit. Työtehoseuran maatalous- ja rakennusosaston monisteita 2/1988. 157 p.
- ANON.** 1992. Karjasuojien vesiensuojelua koskeva valvontaohje 61 ja siihen 3.4.1992 tehdyt muutokset. Vesi- ja ympäristöhallitus. 11 p.
- JUSSILA, L. & PENTTILÄ, A.** 1996. Kompostisikalan hoitokone. Koneviesti 44, 2: 6-7.
- KAUFMANN, R., HELLER, W. & BIERI, M.** 1997. Nährstoffbilanz im Kompoststall für Mastschweine. Argarforschung 4 (1): 25-28.

- KETOLA, U.** 1994. Tuottajien kokemuksia kompostikuivikejärjestelmistä 1994. LSO Alkutuotanto. 13 p. (saatavana LSO, Forssa)
- KLEMOLA, E.** 1998. Purupohjaiset sikalat. Työtehoseuran julkaisuja 385. 82 p.
- KOLHI, I.** 1995. Kompostikuivikejärjestelmä. Opas ja tuottajien kokemukset-95. Päättötyö. Uudenmaan maaseutuopisto, Hyvinkää. 29 p.
- KOLHI, I.** 1995. Kompostikuivike järjestelmä. Opas ja tuottajien Kokemu Kset-95. Päättötyö. Uudenmaan maa seutuopisto, Hyvinkää. 29 p.
- KOTKASAARI, T. & VÄÄNÄNEN, E.** 1996. Maatalousrakennusten mitoitus MRO C 1. Maa- ja metsätalousministeriö. 19 p.
- LAINEN, K.** 1997. Purupohjasikalaselvitys. Maa- ja metsätalousministeriö. Maaseutu- ja luonnonvaraosasto. Rakentamisyksikkö. 23 p.
- PENTTILÄ, A.** 1995. Alkukasvatus purupohjalla. Koneviesti 43, 17: 12-13, 15.
- PENTTILÄ, A.** 1996. Traktorikäyttöinen purusikalan kääntölaite. Koneviesti 44, 10: 14-15.
- PUUMALA, M. & PYYKKÖNEN, M.** 1997. The energy balance of the sawdust deep litter system. NJF Technia '97. NJF-Seminar 272, 1-12. 5 p.
- PYYKKÖNEN, M.** 1994. Alustava selvitys purupohjan toiminnasta sikalassa. Raportti. 11 p. (Saatavana MTT/Vakola, Vihti).
- PYYKKÖNEN, M.** 1995. Purupohjan ongelmille etsitään ratkaisuja. Lihatalous 53, 7: 18-19.
- PYYKKÖNEN, M.** 1996. Viljelijöitä ei pidä yllättää toimimattomaan systeemiin. KM Vet 2, 4: 6-7.
- SUOMI, A.** 1995. Kompostipohjainen sikala tarvitsee hyvän ilmastoinnin. KM Vet 1, 3: 11.

**Chairman's summary of part 5.**  
**Environmental impacts**  
**Claude CHEVERRY**

Seven papers were presented during this session. The authors mainly focused on three themes. The first of them was devoted to the metal contents in the animal wastes (4 papers) :

Chambers and al. have studied the heavy metal contents of a range of animal manures. Their objective was to give an indication of the « typical concentrations », to enable manure metal concentrations to be predicted from a knowledge of feed metal analysis and finally to identify areas where those heavy metals may be accumulating at high rates (in East Anglia, UK).

Menzi and Kessler analysed the content of Cu, Zn, but also of Cd and Pb in about 1200 manure samples. They demonstrated that the mean (median) content of Cu and Zn in pig manures, and the Cd and Pb content in cattle, pig and poultry manure have decreased considerably during the last ten years, in Switzerland. At average animal density and mean heavy metal contents, heavy metal inputs in manures clearly exceed plant uptake only for Zn in pig and poultry production.

L'Herroux and al. studied an experimental field (« Solepur ») which can be considered as a simulation model for what happens to metals in pig slurry under normal field conditions over a long period of time. Their results show that Cu and Zn accumulate in the surface layer of the soil and very little downward metal movement was observed.

Cabral and al. conducted a lysimeter experiment using wheat plants on two texturally contrasted soils. Their results show that increasing additions of solid phase from pig slurry significantly enhance extractable Cu, Zn, Fe and Mn content in the top soil, and of Fe, Mn and Zn (but not of Cu) in the plants.

The second theme was related to the hygienic problems linked to storage and landspreading of animal or human manures (2 papers) :

Martens and al. studied the experimental risk when slurry is delivered to central treatment plants. Most of the plants, namely those with a pasteurisation step and those with thermophilic processes succeeded to inactivate most of the tested microorganisms (ECBO, ERV, BPV..). in some plants, the way of running the process is not optimal.

Hoglund and al. measured concentrations of faecal indicators organisms in 14 human urine collection tanks at two occasions. It appears that after the six months storage generally applied for source separated urine, the hygienic quality of the urine can be considered as satisfactory.

The third theme was devoted to the problems of handling of manure in the deep-litter pig houses ( one paper : Klemola and Malkki). The key issue in the sawdust deep-litter method is the functionality of the compost, which affects the well-being of the pigs, the amount of work in taking care of the bedding, and also the production costs. The main problems in the functioning and handling of those litters (specially during winter) have been described by the authors.

## List of participants

Name	Title	Organisation	Address	Postcode	Town	Country
AMON Barbara	Ing	Institute Landtechnik,	Universitat F Bodenkultur, Nussdoreer Lande 29-31,	1190	Vienna	Austria
AMON Thomas	Dr	Institute Landtechnik,	Universitat F Bodenkultur, Nussdoreer Lande 29-31,	1190	Vienna	Austria
ARKHIPCHENKO Irina	Prof	Research Institute for Agricultural Microbiology	Podbelsky Shossee, 3,	189620	St Petersburg- Pushkin - 8	Russia
AUBERT Claude	Mr	ITAVI	Zoopôle Beaucemaine, BP 37,	22440	Ploufragan	France
AUDOIN Emmanuel	Mr	U.G.P.V.B.	104, rue E. Pottier, BP 6613,	35066	Rennes Cedex	France
BALSARI Paolo	Dr	Dipartimento di Economia Ingenieria Agraria, Forestale Ambientale	Universita Degli Studi di Torino, Via Leonardo da Vinci 44,	10095	Grugliasco - Torino	Italy
BELINE Fabrice	Mr	Cemagref	17, avenue de Cucillé,	35044	Rennes Cedex	France
BERNAL Maria-Pilar	Dr	Centro de Edafologia y Biologia Aplicada del Segura, CSIC	Avda de la Fama n°1,	30003	Murcia	Spain
BODET Jean-Marie	Mr	I.T.C.F.	Station Expérimentale de la Jaillièrre,	44370	Varades	France
BOHM Reinhard	Prof. Dr	Universität Hohenheim	Institute für Umwelt - Und Tierhygiene Sowie, Tiermedizin Mit Tierklinik,	D-70593	Stuttgart	Germany
BOUANANI Fatiha	Mme	Université de Provence. Laboratoire Chimie et Environnement	Case 29, 3 place Victor Hugo,	13331	Marseille Cedex 3	France
BREWER Alan	Mr	Farming and Rural Conservation Agency	FRCA, Nobel House, 17 Smith Square,	SW1P 3JR	London	United Kingdom
BRIANT André	Mr	La Fenetrie		37500	Marcay	France
BUELNA Gerardo	Dr	Centre de Recherche Industrielle du Québec (CRIQ)	333, rue Franquet, Sainte-Foy,		Quebec	Canada
BURTON Colin	Mr	Silsoe Research Institute	Wrest Park, Silsoe,	MK45 4HS	Bedford	United Kingdom
CABRAL Fernanda	Dr	Instituto Superior Agronomia DQAA	TAPADA DA AJUDA,	P1399	Lisbon Codex	Portugal
CASEBOW Andrew	Dr	Agricultural and Environment Adviser	Bailiffs Cross, St. Andrews,	GY68RJ	Guernsey	United Kingdom
CAUPIN Henri-Jean	Mr	ELF ATOCHEM	La Défense 10, Cedex 42,	92091	Paris La Defense Cedex	France
CELAN Stefan	Ing	Institute Bistra Technologie Zentrum	Mestni Trg 1,	2250	Ptuj	Slovenia



CELLIER Pierre	Mr	I.N.R.A.	Station de Bioclimatologie,	78850	Thiverval Grignon	France
CHADWICK David	Dr	IGER	North Wyke, Okehampton,	EX20 2SB	Devon	United Kingdom
CHAMBERS Brian	Dr	ADAS Gleadthorpe Research Centre	Meden Vale, Mansfield,	NG20 9 PF	Nottinghamshire	United Kingdom
CHATAIGNER Jean	Mr		VERT,	07430	Vernosc Les Annonay	France
CHAUSSOD Remi	Dr	I.N.R.A.	17, rue de Sully, BV 1540,	21034	Dijon	France
CHEVERRY Claude	Prof	ENSA. INRA	Laboratoire de Science du Sol, 65, route de St Brieuc,	35042	Rennes Cedex	France
CHRISTIE Peter	Dr	Department of Agriculture for Northern Ireland	Agricultural and Environmental Science Division, Newforge lane.	BT9 5PX	Belfast	United Kingdom
COOLS Danielle	Mrs	K.U. LEUVEN	Lab. of Soil Fertility and Soil Biology, Kardinaal Mercierlaan 92,	3001	Heverlee	Belgium
COROVIL Claudia	MdS	Instituto Superior Agronomia DQAA	TAPADA DA AJUDA,	P1399	Lisbon Codex	Portugal
COULOMB-VEUDEUVRE I.	Mme	SITA.	Technopôle CNPP. BP 2265, Route de la Chapelle Réanville,	27950	Saint Marcel	France
DA BORSO Francesco	Dr	Univ. of Udine - Italy	Via Delle Scienze, 208,	33100	Udine	Italy
DACH Jacek	Mgr. ing.	Academy of Agriculture	Wojska Polskiego 50,	60-627	Poznan	Poland
DAVIS Robert	Dr	WRc plc	Henley Road, Medmenham, Marlow,	SL7 2HD	Bucks	United Kingdom
DE GUARDIA Amaury	Dr	Cemagref	17, avenue de Cucillé,	35044	Rennes Cedex	France
DERIKX Piet	Dr	Institut voor Mechanisatie. Arbeid en Gebouwen (IMAG-DLO)	Mansholtlaan 10-12, PO. Box 43.	6700 AA	Wageningen	Holland
DOLLE Jean-Baptiste	Mr	Institut de l'Elevage	57, avenue Roger Salengro, BP 32,	62051	St Laurent Blanzey	France
ELLOUET Catherine	Prof	Université de Bretagne Occidentale UMR 6521	6, avenue Victor le Gorgeu,	29285	Brest Cedex	France
ELMQUIST Helena	PhD	Swedish Institute of Agricultural Science	Division of Soil Management, PO Box 7014,	S-750 07	Uppsala	Sweden
FABBRI Claudio	Dr	Centro Ricerce Produzioni Animali (CRPA)	Via Crispi 3, Corso Garibaldi 42,	42100	Reggio Emilia	Italy
FARDEAU Jean-Claude	Dr	CEA/INRA	Science du Sol, Route de St Cyr,	78000	Versailles	France
FAUVEL Yannick	Mr	I.N.R.A.	65, rue de St Brieuc,	35042	Rennes Cedex	France
FLURA Dominique	Mr	I.N.R.A.	Station de Bioclimatologie,	78850	Thiverval Grignon	France
FRANKINET Marc	Mr	Centre de Recherche Agronomique	Département Production Végétale, Chemin de Liroux 11,	5030	Gembloux	Belgium

GENERMONT Sophie	Mme	I.N.R.A.	Station de Bioclimatologie,	78850	Thiverval Grignon	France
GOSS Michael	Mr	University of Guelph	Department of Land Ressource Science, Guelph,	N1G 2W1	Ontario	Canada
GUINGAND Nadine	Mme	Institut Technique du Porc	BP 3,	35650	Le Rheu	France
GUIZIOU Fabrice	Mr	Cemagref	17, avenue de Cucillé,	35044	Rennes Cedex	France
HACALA Sylvie	Mme	Institu de l'Elevage	14, avenue Jean Joxé, BP 646,	49006	Angers Cedex 01	France
HALL Jeremy	Mr	WRc plc	Henley Road, Medmenham, Marlow,	SL7 2HD	Buckinghamsh ire	United Kingdom
HEINONEN- TANSKI Helvi	Dr	University of KUOPIU	Department of Environmental Sciences, POB 1627,	FIN 70211	Kuopiu	Finland
HERTER Ulrich	Dr	Swiss Federal Research Station for Agroecology and Agriculture	Reckenholzstr. 191,	CH-8046	Zurich- Reckenholz	Switzerland
HOBBS Philip	Dr	IGER	North Wyke, Okehampton,	EX20 2SB	Devon	United Kingdom
HOERNIG Günter	Prof. Dr	Institute of Agricultural Engineering Bornim	Max-Eyth Allee 100,	D-14468	Potsdam- Bornim	Germany
HOGLUND Caroline	Mrs	Swedish Institute for Infectious Disease Control	Department of Water and Environmental Microbiology,	10521	Stockholm	Sweden
HOUOT Sabine	Dr	I.N.R.A. Science du Sol	Centre de Grignon, BP 01,	78850	Thiverval Grignon	France
HRAZDIRA Jaroslav	Dr	Lhoist Ltd. Praha	Bavorska 856,		Praha	Czech Republic
HUIJSMANS Jan	Ir	Institute of Agricultural and Environmental Engineering	(IMAG-DLO), PO Box 43,	6700 AA	Wageningen	The Netherlands
HUNT Patrick	Dr	USDA-ARS/NCSU	Coastal Plains Soil, Water and Plant Research Center, 2611 W. Lucas St.,	29501-1242	Florence, SC	USA
HURVOIS Yvan	Mr	Agence de l'Eau Loire Bretagne	1, rue Eugène Varlin, BP 40521,	44105	Nantes Cedex 04	France
JAFFREZIC Anne	Dr	I.N.R.A.	Sciences du Sol, 65, rue de St Brieuc,	35042	Rennes Cedex	France
JULIAN Marie-Pierre	Mme	SOLAGRO	219, avenue de Muret,	31300	Toulouse	France
JURIS Peter	PhD	Parasitological Institute SAS	Hinkova 3,	04001	Kosice	Slovakia
KERMARREC Christophe	Mr	I.N.R.A.	Laboratoire de Bioclimatologie, 65, rue de St Brieuc,	35042	Rennes Cedex	France
KLIR Jan	Dr	Research Institute of Crop Production	Drnovska Street 507,	CZ 161-06	Praha 6 - Ruzyně	Czech Republic
KOUTEV Vesselin	PhD	N. Poushkarov Institute of Soil Science and Agroecology	Agrochemistry' Departm ent, 7 Chaussee Bankya,	1080	Sofia	Bulgaria

KRELL Rainer	Mr	FAO	Regional Office for Europe (REUR), Via delle Terme di Caracalla,	00100	Rome	Italie
KUSA Helena	Dr	Research Institute of Crop Production	Dmnovska 507,	161 06	Praha 6 - Ruzyně	Czech Republic
LE BOZEC Gildas	Mr	Cemagref	17, avenue de Cucillé,	35044	Rennes Cedex	France
LE GALL André	Mr	INSTITUT DE L'ELEVAGE	Monvoisin,	35650	Le Rheu	France
LECLERCQ O.	Mr	SITA.	Technopôle CNPP. BP 2265, Route de la Chapelle Réanville,	27950	Saint Marcel	France
LENEHAN J.J.	Mr	Teagasc	Grange Research Centre Oak Park, Dunsany,		Co. Meath	Ireland
LINERES Monique	Dr	I.N.R.A.	71, avenue Edouard Bourleaux, BP 81,	33140	Villeneuve D'ornon	France
LORENZ Frank	Dr	Landwirtschaftliche Untersuchungs und Forschungsanstalt (LUFA)	der Landwirtschaftskammer Weser-Ems, Jaegerstr.23-27,	26121	Oldenburg	Germany
LUPTON Sylvie	Mme	CIRED. Laboratoire d'Econométrie	Ecole Polytechnique, 1, rue Descartes,	75005	Paris	France
MACHET Jean-Marie	Ing	I.N.R.A.	Rue Fernand Christ,	02000	Laon	France
MADEC	Mr	CNEVA	Zoopôle les Croix,	22440	Ploufragan	France
MAGETTE William	Dr	Agricultural and Food Engineering Department	University College Dublin, Earlsfort Terrace,		Dublin 2	Ireland
MALGERYD Johan	Mr	Swedish Institute of Agricultural Engineering	PO Box 7033,	SE 75007	Uppsala	Sweden
MALKKI Sirkka	Dr	TTS - INSTITUTE	Work Efficiency Institute, P.O. Box 13,	FIN-05201	Rajamaki	Finland
MANFREDI Daniel	Dr	Services Vétérinaires	7, rue Turgot,	29334	Quimper Cedex	France
MARCOVECCHIO Fabrice	Mr	Station Agronomique de l'Aisne	Rue Fernand Christ,	02000	Laon	France
MARQUET Jérôme	Mr	AGRALCO	Service Environnement,	53220	Pontmain	France
MARREC Jacques	Mr	ENSA. INRA	Laboratoire de Science du Sol, 65, route de St Brieuc,	35042	Rennes Cedex	France
MARTEL Jean-Luc	Mr	SITA.	Technopôle CNPP. BP 2265, Route de la Chapelle Réanville,	27950	Saint Marcel	France
MARTENS Wolfram	Dr	Institute for Environmental and Animal Hygiene	University of Hohenheim,	D-70593	Stuttgart	Germany
MARTH Peter	Mr	Plant Health and Soil Conservation Station of Budapest	Budaörsi ut 141-145,	1118	Budapest	Hungary
MARTINEZ José	Dr	Cemagref	17, avenue de Cucillé,	35044	Rennes Cedex	France
MASSE D.	Dr	Agriculture Canada	Dairy and Swine Research and Development Centre Agriculture, P.O. Box 90 2000 Route 108 EAST,	J1M 1Z3	Lennoxville (Quebec)	Canada

MASSICOTTE	Mr	Centre de Recherche Industrielle du Québec	333, rue Franquet,		Sainte-Foy (Quebec)	Canada
MATSUDA Juzo	Prof	Department of Agricultural Engineering	Hokkaido University, KITA 9. NISHI 9. KITA-KV,	060-8589	Sapporo	Japan
MENZI Harald	Dr	Institute of Environmental Protection and Agriculture (IUL)	Liebefeld,	CH-3003	Berne	Switzerland
MERILLOT Jean-Marc	Mr	ADEME	2, square La Fayette, BP 406,	49004	Angers	France
MESZAROS György	Dr	Hungarian Institute of Agricultural Engineering, HIAE	Quality Testing Society p.u, Tessedik Su 4,	H-2100	Godollo	Hungary
MISSELBROOK Thomas	Mr	(IGER)	North Wyke, Okehampton,	EX20 2SB	Devon	United Kingdom
MORAND Philippe	Mr	CNRS Université Rennes 1	U.M.R. 6553, Station Biologique,	35380	Paimpont	France
MORKS P.	Mr	SITA.	Technopôle CNPP. BP 2265, Route de la Chapelle Réanville,	27950	Saint Marcel	France
MORVAN Thierry	Mr	INRA	65, rue de St Brieuc,	35042	Rennes Cedex	France
NICHOLSON Fiona	Dr	ADAS Gleadthorpe Research Centre	Meden Vale, Mansfield,	NG20 9PF	Nottinghamshire	United Kingdom
NICHOLSON Robert	Mr	ADAS	Boxworth, Battlegate Road,	CB3 7SB	Cambridge	United Kingdom
NICOLARDOT Bernard	Dr	INRA Unité d'Agronomie de Chalons-Reims	2, Esplanade Roland Garros, BP 224,	51686	Reims Cedex 2	France
OLASZ Zsuzsa	Mrs	Plant Helath and Soil Conservation Station of Budapest	Budaörsi ut 141-145,	1118	Budapest	Hungary
OLIVEIRA Paulo Armando	Mr	I.N.R.A.	Laboratoire de Bioclimatologie, 65, rue de St Brieuc,	35042	Rennes Cedex	France
PAIN Brian	Dr	IGER	North Wyke, Okehampton,	EX20 2SB	Devon	United Kingdom
PARNAUDEAU Virginie	Mme	INRA	2, Esplanade R. Garros,	51686	Reims Cedex 2	France
PATNI Naveen	Dr	Pacific Agri-Food Research Centre	Box 1000, 69407 H7 Highway,	AGASSIZ	British Columbia	Canada
PAULSRUD Bjarne	Mr	AQUATEAM	Norwegian Water Technology Centre as, PO Box 6875 Rodeloekka,	D504	Oslo	Norway
PEU Pascal	Mr	Cemagref	17, avenue de Cucillé,	35044	Rennes Cedex	France
POCHAT Rémi	Mr	Cemagref	Département Equipements pour l'Eau et l'Environnement, BP 44,	92163	Antony Cedex	France
PROVOLO Giogio	Dr	Istituto di Ingegneria Agraria	Via Celoria 2,	I-20 133	Milano	Italy
QUINTEL François	Prof	Université de Bretagne Occidentale UMR 6521	6, avenue Victor le Gorgeu,	29285	Brest Cedex	France

REITZ Petra	Ing	University of Hohenheim	Institute of Agricultural Engineering (440LT) Garbenstr.9,	D-70599	Stuttgart	Germany
REYNE Sandrine	Mme	SCE Environmental Consultants	Atlanpôle, BP 10703,	44307	Nantes Cedex 3	France
ROBERT Michel	Dr	Ministère de l'Aménagement du Territoire et de l'Environnement	20, avenue de Ségur,	75007	Paris	France
ROBIN Paul	Dr	INRA	Laboratoire de Science du Sol, 65, route de St Brieuc,	35042	Rennes Cedex	France
ROGEAU Didier	Mr	Cemagref	17, avenue de Cucillé,	35044	Rennes Cedex	France
SALAZAR Francisco	Mr	IGER	North Wyke, Okehampton,	EX20 2SB	Devon	United Kingdom
SANGIORGI Franco	Prof	Instituto di Ingegneria Agraria	Via Celoria 2,	I-20 133	Milano	Italy
SATTER Inge	Mse	IMAG - DLO	Mansholtlaan 10-12,		Wageningen	The Netherlands
SENEZ Laurent	Mr	I.N.R.A.	17, rue de Sully, BV 1540,	21034	Dijon	France
SIEGENTHALER Albrecht	Mr	Institute of Environmental Protection and Agriculture	Liebefeld, Schwarzenburgstr.155,	CH-3003	Berne	Switzerland
SKJELHAUGEN Odd Jarle	Dr	The Agricultural University of Norway	Department of Agricultural Engineering, PO Box 5065,	N-1432	As Nih	Norway
SMYTH Sara	Ms	Agricultural Food Engineering	University College Dublin, Earlsfort Terrace,		Dublin 2	Ireland
SOMMER Sven Gjedde	Dr	Dept. of Agricultural Engineering	Research Centre Foulum, PO Box 536,	DK- 8700	Horsens	Denmark
STEFFENS Guenther	Dr	Landw Untersuchungs und Forschungsanstalt (LUFA)	Jagerstrasse 23-27,	26121	Oldenburg	Germany
THIRION François	Mr	Cemagref	Site de Montoldre, Domaine des Palaquins,	03150	Varenes Sur Allier	France
TOFFOLET R.	Mr	SITA	Technopôle CNPP. BP 2265, Route de la Chapelle Réanville,	27950	Saint Marcel	France
TROCHARD Robert	Mr	ITCF	Station Expérimentale de la Jaillièrè,	44370	Varades	France
TROLARD Fabienne	Dr	INRA	Sciences du Sol et Bioclimatologie, 65, rue de St Brieuc,	35042	Rennes Cedex	France
UNWIN Roger	Mr	FRCA MAFF	Nobel House, 17, Smith Square,	SW1 3JR	London	United Kingdom
VAN GASTEL Jos	Ing	TMS Technick	Schuurkenspad 7,	5986 PD	Beringe	The Netherlands
VAN WAGENBERG Coen	Dr	Praktiskonderzoek Varkenshouderij	Lunerkampweg 7, Postbus 83,	5240 AB	Rosmalen	The Netherlands
VANOTTI Matias	Dr	USDA-ARS/NCSU	Coastal Plains Soil, Water and Plant Research Center, 2611 W. Lucas St.,	29501-1242	Florence, SC	USA

VENGLOVSKY Jän	Dr	Ministry of Agriculture	Research Institute of Experimental Veterinary Medicine, Hlinkova 1/A,	O4001	Kosice	Slovakia
VINNERAS Bjorn	Dr	Swedish University of Agricultural Sciences	Department of Agricultural Engineering, P.O. Box 7033,	S-750 07	Uppsala	Sweden
VLASSAK Karel	Prof	K.U. LEUVEN	Lab. of Soil Fertility and Soil Biology, Kardinaal Mercierlaan 92,	3001	Heverlee	Belgium
WILLIAMS John	Mr	ADAS Boxworth	Battlegate Road, Boxworth,	CB3 8NN	Cambridge	United Kingdom
WOLTERS H.	Mr	TMS Techniek	Schuurkenspad 7,	5986 PD	Beringe	Holland



## **Farewell and Acknowledgements**

Mr J. Hall announced that after eight years as Network Coordinator, he was standing down. Dr J. Martinez was proposed and unanimously elected as the new Coordinator. Mr J. Hall congratulated all of the participants for their high quality contributions which had ensured the success of the meeting. He also thanked everyone for their help and support over the last eight years as Coordinator and he congratulated Dr J. Martinez in his appointment as the new Coordinator. He also thanked Dr Martinez and his staff for their hard work and excellent organisation of the conference.

The sponsors of the meeting were also thanked, without whose support the conference would not have been possible. These sponsors were: SITA, Elf Atochem, UCAAB Group, Regional Council of Brittany, Rennes City and Cemagref.

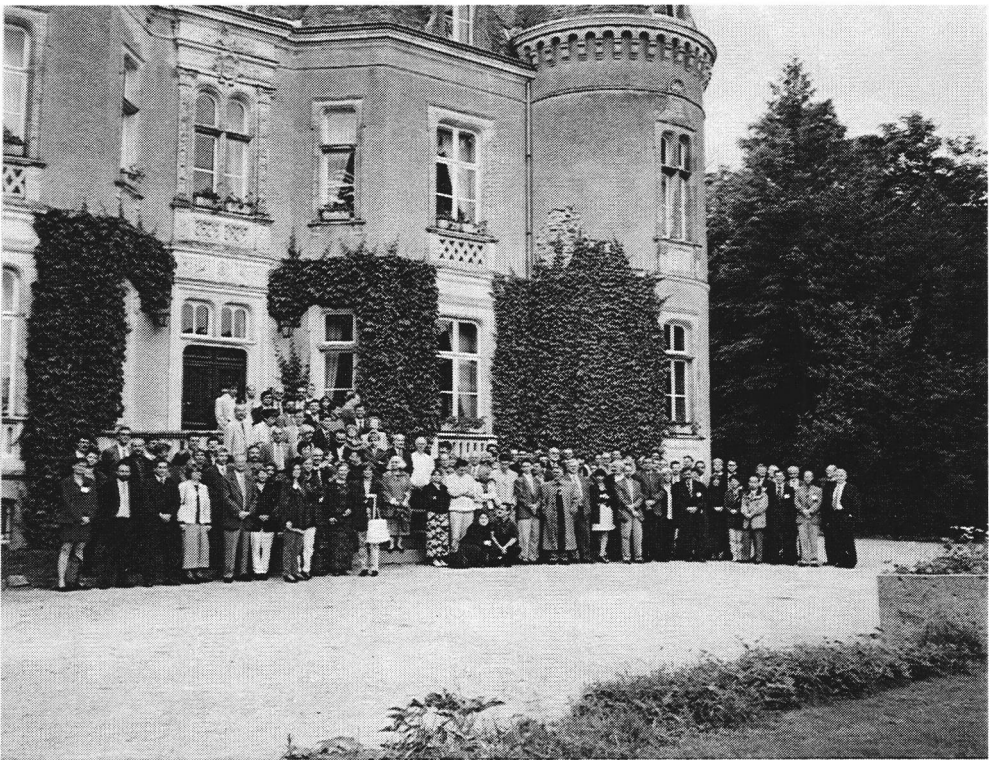

*Photo of the RAMIRAN Network Group  
at the Castle « La Bicheptière ».*





This volume contains the Proceedings of the 8th International Conference of the FAO ESCORENA Recycling of Agricultural, Municipal and Industrial Residues in Agriculture Network (RAMIRAN), held in Rennes, France, from 26 to 29 May 1998. The theme of the Conference was Management Strategies for Organic Waste Use in Agriculture and the Conference was divided into five parts:

- Management strategies for organic waste use in agriculture
  - Agronomic value of organic wastes
  - Measurement, modelling and control of gaseous emissions
  - Processing and handling of wastes
    - Environmental impacts

The book brings together the leading workers in the area and provides an up-to-date account of the research along with implications for practical recommendations in this environmentally sensitive field.

These considerations led us to the conclusion that this book is timely and fills a void on a subject that lacks integrated scientific information.

Ce volume rassemble les actes de la 8<sup>e</sup> conférence internationale d'un réseau FAO, sur le Recyclage des déchets agricoles, municipaux et industriels en agriculture, qui s'est tenue à Rennes du 26 au 29 mai 1998. La conférence avait pour thème les stratégies de gestion des déchets organiques utilisés en agriculture, et elle était organisée en 5 parties :

- Stratégies de gestion des déchets organiques utilisés en agriculture
- Valeur agronomique des déchets organiques
- Mesure, modélisation et maîtrise des émissions gazeuses
- Traitement et gestion des déchets
- Impacts environnementaux

Cet ouvrage rassemble les principaux auteurs impliqués sur ce domaine de recherche, et présente, à la fois les derniers résultats de leurs travaux, mais également des considérations pratiques, nécessaires pour assurer une gestion optimisée des déchets organiques en agriculture.



ISBN 2-85362-516-8

