



HAL
open science

Association of stabilization ponds and intermittent sand filters: an appropriate wastewater treatment system for small communities

A. Torrens, Pascal Molle, Catherine Boutin, M. Salgot

► To cite this version:

A. Torrens, Pascal Molle, Catherine Boutin, M. Salgot. Association of stabilization ponds and intermittent sand filters: an appropriate wastewater treatment system for small communities. 7th Specialised Conference on Small Water and Wastewater Systems, Mexico, MEX, 7-10 mars 2006, Mar 2006, Mexico, Mexico. pp.9. hal-02588336

HAL Id: hal-02588336

<https://hal.inrae.fr/hal-02588336>

Submitted on 26 May 2021

HAL is a multi-disciplinary open access archive for the deposit and dissemination of scientific research documents, whether they are published or not. The documents may come from teaching and research institutions in France or abroad, or from public or private research centers.

L'archive ouverte pluridisciplinaire **HAL**, est destinée au dépôt et à la diffusion de documents scientifiques de niveau recherche, publiés ou non, émanant des établissements d'enseignement et de recherche français ou étrangers, des laboratoires publics ou privés.

Association of Stabilization Ponds and Intermittent Sand Filters: an appropriate wastewater treatment system for small communities.

Antonina Torrens*, Pascal Molle**, Catherine Boutin*** and Miquel Salgot*

*Soil Science Laboratory, Faculty of Pharmacy, University of Barcelona. Avda. Joan XXIII s/n. 08028, Barcelona. Spain. (E-mail: antoninatorrens@ub.edu; salgot@ub.edu)

**Cemagref, Research Unit: Water quality and pollution prevention, 3bis, quai Chauveau, F 69336 Lyon Cedex 09, France (E-mail: molle@lyon.cemagref.fr)

***Conseil Général du GREF, Mission d'Appui Technique aux services déconcentrés, 140 bis r de Rennes, 75006 Paris. (E-mail: catherine.boutin@agriculture.gouv.fr)

Abstract

For the treatment of wastewater generated by a small community (Aurignac), a scheme was built consisting on a Settling Tank (ST), a Wastewater Stabilization Pond (WSP) and Intermittent Sand Filters (ISFs). The sludge train consists on a device pumping the sludge from the small settling tank before the pond, which is sent to Sludge Dewatering Reed Beds (SDRBs). The performance of the full-scale demonstration facility was evaluated during 2 years. The setting-up of the ST with SDRBs resulted to be a simple and effective option to diminish the SS load (50 %) arriving to the WSP; thus reducing sludge accumulation in the bottom of the WSP. The WSP performed well with high removal rates for all contaminants. The WSP effluent quality was not sufficient according to the limits set by the French regulations for disposal into sensitive areas or for reuse; which corroborates the necessity of an additional treatment. The implementation of ISFs after WSP was confirmed to be a good alternative. The results demonstrated the suitability of this wastewater treatment train for rural communities with combined sewerage system, due to its simplicity for operation and maintenance, the hydraulic capability of the system (allowing the plant to withstand high flow variations) and the high quality of the final effluent (< 100 mg/L COD, <20 mg/L BOD₅, < 20 mg/L SS, < 7 mg/L TKN, < 4 mg/L N-NH₄).

Keywords

Wastewater Stabilization Ponds; Intermittent Sand Filters, Reed Beds; effluent quality; small communities

INTRODUCTION

Waste Stabilization Ponds (WSPs) have been a treatment system preferred in developing and non-developing countries, and they are also a particularly suitable wastewater treatment for small communities. The most significant advantages of WSPs are their simplicity, low cost of construction-operation and the capability of withstanding hydraulic shock loadings. Nevertheless, in spite of these advantages, the high concentrations of microalgae in the effluent can limit the practical application of this system (WEF, 1992).

For small communities, in the case of fragile receiving bodies, the effluent quality is not always sufficient according to the limits set by some regulations (i.e. French Quality Level D4: <125 mg/L COD; < 25 mg/L BOD₅). In effect, the classical WSP configuration doesn't permit to achieve these limits in France (Racault *et al.*, 1995). As a result, a complementary treatment is required. Several technologies have been proposed for upgrading pond quality effluent (Middlebrooks, 1995; Sezerino *et al.*, 2003; Johnson and Mara, 2005). It would be desirable that these post-treatments also ensure that the global treatment system will maintain the primordial advantages of the WSPs (easy operation and maintenance, environmental integration). The implementation of Intermittent Sand Filters (ISFs) as polishing treatment after WSP can offer a solution to the previous concern due to the potentialities of these technologies for retaining algae (Neder *et al.*, 2002; Kayser *et al.* 2002), removing organic matter and nitrifying the ISF influent.

Additionally, it is also to consider that the small wastewater treatment plants need to manage the small amount of sludge they generate. Ponds produce about 2 cm/year of wet anaerobic sludge (110L/Person Equivalent (PE)/year) (Racault and Boutin, 2005); which must be removed

periodically to keep the pond performing properly. Taking into account the loading conditions of WSPs in France, it seems necessary to remove the sludge approximately every 10 years. Desludging represents a major factor of maintenance operational costs in WSPs (Cavalcanti *et al.*, 2002; Racault and Boutin, 2005). In order to reduce these costs the association of a Sedimentation Tank (placed upstream the pond) and Sludge Dewatering Reed Beds can work as a solution.

In this context, a new treatment line using an association of WSP and ISFs plus a sludge line was purposely built in Aurignac, a small village in France, as a full scale demonstration facility. The aim of this study is to propose a wastewater treatment train for rural districts (with combined sewerage network) easy to operate; associating the hydraulic capacity of a pond system with the qualitative performance of intermittent sand filtration premises. This paper presents the results of more than two years of plant monitoring. The performance of each stage of the Wastewater Treatment Plant (WWTP), the first design bases and the advantages and inconveniences of the different configurations are discussed in terms of performance, operation and maintenance.

MATERIALS AND METHODS

Experimental plant

The study was performed in the experimental full-scale plant of Aurignac, in the Haute-Garonne Department (France). The WWTP is designed for 300 PE and the sewerage system is of combined type. The plant has been in operation since July 2003 and consists of a Settling Tank (ST), a pond and six Intermittent Sand Filters (ISFs) in parallel (Figure 1). Primary sludge is extracted each day from the bottom of the ST (1.5 m³ of useful volume) placed upstream the pond and is pumped towards four Sludge Dewatering Reed Beds (SDRBs). Each bed has a surface of 17 m²; a depth of 55 cm and is planted with *Phragmites australis*. The filters are alternately fed; with a feeding/rest period of 7/21 days. After percolating through the SDRBs the treated lixivate is recycled to the settler. The facultative pond, with a surface of 2100 m², has a supplementary freeboard of 50 cm allowing the storage of a part of the storm waters drained by the combined sewerage network. Therefore, the water heights can fluctuate between 80 and 130 cm (there is a by-pass at 130cm). The theoretical Hydraulic Retention Time (HRT) is 45 days.

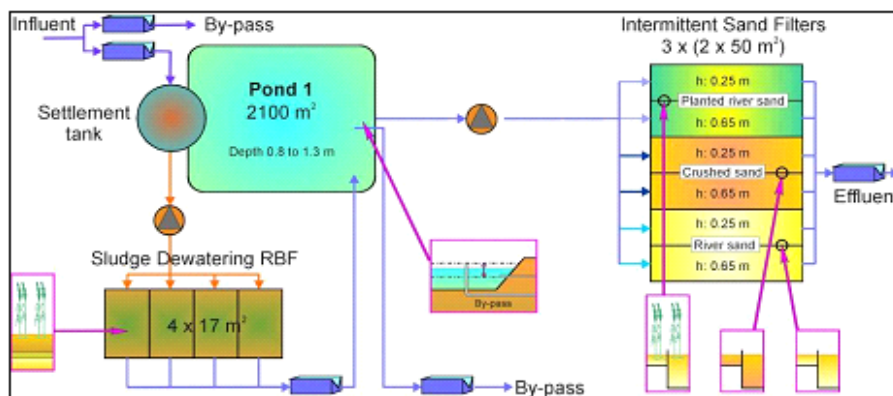

Figure 1. Layout of the Aurignac WWTP (from Boutin *et al.*, 2002)

After the pond, there are 6 independent ISFs of 1 m²/PE filled with 3 different media (river sand, river sand planted with *Phragmites australis*, and crushed sand). The granulometry of the sands has been chosen according to the up-to-date recommendations in France (Liénard *et al.*, 2001). For each type of media two filter depths are used: 25 and 65cm. ISFs are alternately fed: the two filters of the same media are fed at the same time during 3 or 4 days and then rest for 1 week. The instrumentation implemented permitted to follow up continuously the hydraulic behavior of the whole WWTP (flows, pond water level, infiltration rates of filters) as well as the climatic conditions (temperature, humidity, solar radiation, rainfall) and the temperatures inside the pond and filters. All these data, which could be locally or remotely accessed, were recorded

continuously on an electronic central station of data acquisition minute by minute.

Sampling and methods

Physicochemical and microbiological parameters were evaluated in each component of the plant: (a) WWTP inlet, (b) ST outlet (c) SDRBs outlet, (d) WSP outlet and (e) ISFs outlet. Analysis of 24-hours composite-samples (40 campaigns) and grab samples (collected weekly) were performed from September 2003 to October 2005. COD, SS, TKN, N-NH₄, N-NO₃, and TP were analyzed according to French standard methods (AFNOR, 2005). The bacteriological indicators (fecal coliforms (FC) and *E. coli*) were evaluated according to the protocol for membrane filter procedures of Standard methods (APHA, 1998). The quantitative and qualitative algal biomass evolution has been also studied in the pond by optical microscopy and Chlorophyll-a analysis (AFNOR method NT 90-117).

RESULTS AND DISCUSSION

On the whole study, the station received on average 53 m³/d (30 m³/d in dry periods and 70 m³/d in rainy periods). The relatively frequent pluviometry in the area of Aurignac (approximately 50% of time) induced important hydraulic overloads with maximum loads up to 500 m³/d. The average overall loading received by the plant of 25 kg BOD₅/ha.d is representative of the average organic loads of WSPs in France estimated in 24 kg BOD₅/ha.d (Racault *et al.*, 1995). Table 1 presents the characteristics of the WWTP inlet in rainy and dry periods. The inlet concentrations measured in dry periods are characteristic of water resulting from combined sewerage networks (Racault *et al.*, 1995).

Table 1. Characteristics of the WWTP inlet

		COD (mg/L)	BOD ₅ (mg/L)	SS (mg/L)	TKN (mg/L)	N-NH ₄ (mg/L)	TP (mg/L)	FC CFU/100 mL	<i>E. coli</i> CFU/100 mL
Dry periods	Av	515	188	183	65	52	8.9	2.2e ⁷	1.4e ⁷
	SD	76	26	56	15	11	1.9	1.3e ⁷	9.5e ⁶
Rainy periods	Av	364	n.d.	173	38.2	29.7	6.3	9.5e ⁶	6.4e ⁶
	SD	143	n.d.	154	12	12	2.4	7.9e ⁶	5.4e ⁶

Av (Average); SD (Standard Deviation); n.d. (not determined)

The air temperatures during the study were often up to 30°C in summer and below 0°C in winter.

Performance of the Settling Tank and Sludge Dewatering Reed Beds

The sedimentation tank upstream the pond removed at least 50 % of the SS and about 35 % of the COD of the raw wastewater. On the contrary, the removal of dissolved contaminants and bacterial indicators was not significant. Around 1 m³/d of sludge was extracted from the bottom of the settler and directed towards the four SDRBs. The sludge SS average content was 5.3 g/L with high variations (from 4 to 22g/L), as a result each bed received approximately 28kg/m².year of dry matter. SDRBs percolate was recycled and returned to the settler. The percolate quality and the removal rates of the SDRBs are presented in Table 2. The removal of particulate contaminants was very high; almost all the solids extracted from the settler were retained on the top of the SDRBs.

Table 2. Removal and outlet concentrations (standard deviation) of the SDRBs

	COD	dCOD	SS	TKN	N-NH ₄	TP
Removal (%)	92	48	97	87	62	77
Concentration (mg/L)	301 (91)	187 (51)	90 (45)	27 (7)	15 (6)	6.7 (9.3)

The sludge was dried and mineralized in the beds. Up to now only 5 cm of sludge are accumulated on the filters. The dry matter content (with 50 % of VSS) of the accumulated sludge varied from 20 to 50 % depending on the season and the distance from the feeding point. Analyses of the sludge (data not shown in this paper) confirm that the treated sludge complies with pertinent regulations to be disposed of as agricultural amendment.

Performance of the pond

The average concentrations in the WSPs outlet are presented in Table 3. The quality of the pond effluent is representative of WSPs in France (Racault *et al*, 1995). The mean concentrations reached by the lagoon didn't respect the French quality level D4 (<125 mg/L COD, < 25 mg/L BOD₅) for discharge in sensitive receiving bodies.

Table 3. Average concentration of pollutants in the WSPs effluent and removal efficiency (ST+WSP)

	Dry periods		Rainy periods	
	Average outlet concentration	Removal efficiency	Average outlet concentration	Removal Efficiency ¹
COD (mg/L)	148	89 %	144	53 %
dCOD (mg/L)	93	65 %	98	23 %
BOD ₅ (mg/L)	58	69 %	n.d.	n.d.
SS (mg/L)	48	76 %	45	74 %
TKN (mg/L)	21	70 %	20	45 %
N-NH ₄ (mg/L)	13	72 %	9.6	56 %
TP (mg/L)	3.6	62 %	3.6	41 %
FC (Ulog)	2.7e ⁴	2.5 Ulog	7.9e ⁴	2.0 Ulog
<i>E.coli</i> (Ulog)	2.8e ⁴	2.7 Ulog	5.1e ⁴	2.1 Ulog

¹due to the variability of WSP inlet concentration in rainy periods, only the dry period's removal data are relevant
n.d. not determined

The WSP performed consistently well for the removal of all physicochemical and microbiological parameters. Organic matter elimination was high, especially in winter due to the low concentration of algal cells in the WSP effluent. It is to say that to maintain facultative conditions there must be an algal community in the surface layer (Abis and Mara, 2003) and according to Pearson *et al.* (1987) 300 µ/L chlorophyll-a are required to guarantee stable facultative conditions. However, the removal rates of COD, BOD₅ and dCOD were very high in cold periods although the chlorophyll-a concentration was below 100. It is to note that the removal of nutrients (70% TKN, 72% N-NH₄, 62% TP) and bacterial indicators (≥ 2.5 Ulog) was fairly high. Nevertheless, the physicochemical and microbiological quality of the final WSP effluent was not suitable for discharging in fragile receiving bodies or in reuse which confirmed the need of an additional treatment. As shown in Table 3 the quality of the effluent was not affected by the rainy episodes due to the buffer capacity of the pond; except for the bacterial indicators. It is to note that the water level in the lagoon (of 0.8 m to 1.3 m) could change thus allowing the system to withstand with these rainy episodes. On the contrary, fluctuations in the effluent quality according to the season were observed (Figures 2 and 4). COD, SS and dCOD were higher during the warmer periods and are related to the measured biomass (Figure 3). The chlorophyll-a evolution and the effluent's SS and COD trends suggest that the value of these parameters is greatly influenced by the algal cells presence. The high concentrations of dCOD are probably resulting from the excretion of carbohydrates by the algae; as was observed for the carbohydrates analyses performed during the study (data not shown).

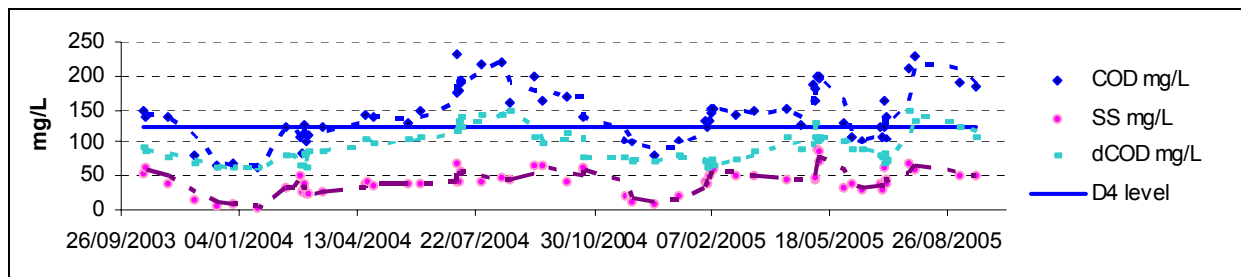

Figure 2. Evolution of COD, dCOD and SS content in the WSPs final effluent

On the other hand, a higher reduction of nitrogen forms and bacterial indicators in warm periods was observed. In summer, ammonia concentrations remained very often under 10 mg/L (Figure 4). The data suggest that ammonia removal also has a seasonal behavior: the improved ammonia elimination in summer was linked with the higher water temperatures and chlorophyll-a concentrations. These results are according to the indications of Liénard *et al.* (2005), and Abis and Mara (2003).

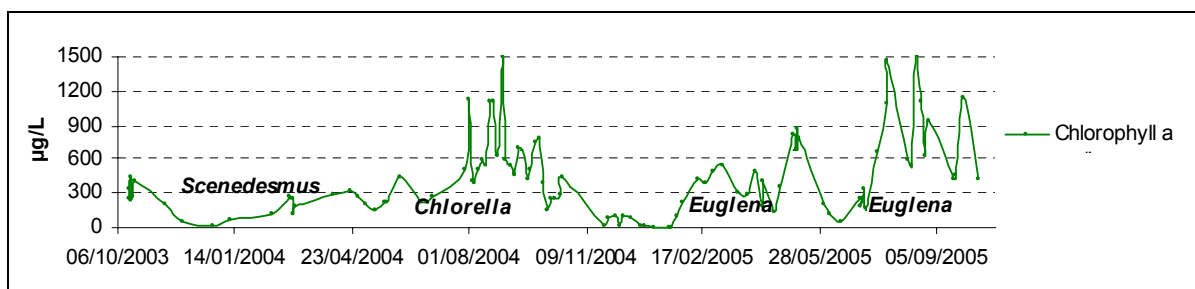

Figure 3. Evolution of Chlorophyll a in the pond and the predominant algae genera.

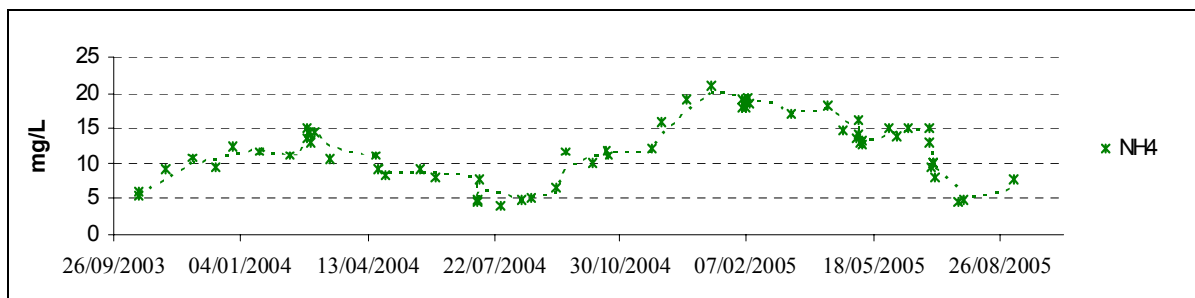

Figure 4. Evolution of N-NH₄ content in the WSPs final effluent

The removal of FC ad *E. coli* was also higher in summer (> 3 Ulog) when the concentrations of chlorophyll-a were important. High ambient temperature, solar radiation and pH due to the growth of algae have been reported to encourage pathogen inactivation and die-off (Davies-Colley *et al.*, 1999; Alcalde *et al.* 2005). The evolution of the algae biomass and the above-mentioned parameters was the same during the 2 years of study. The only exception was the presence of *Daphnia* during June 2006 that caused a decline of the chlorophyll-a content (Figure 3).

Considering the hydraulic capacity of the pond, we observed that the 86 % of the WWTP inlet flow (wastewater and rainwater) was treated in the plant during the period of study. It is to say that quite all the pond by-passed water was due to experimental artifacts (stop of filters feeding, variations of the hydraulic loads applied on the filters, ..). Indeed if the hydraulic load on the filters were kept at 80 cm/d during the whole period, 98,6 % of the WWTP inlet flow would have been stored in the pond and treated by the filters.

Performance of the Intermittent Sand Filters

Different organic and hydraulic loads (HLs) were applied all through the study (20-80 cm/day; 20-170 gCOD/m² during feeding periods). All filters achieved the quality fixed by the French regulations for discharge in sensitive areas with effluent concentrations lower than 100 mg/L for

COD and 20 mg/L for BOD₅ (Table 4). However, it must be noted that the effluent quality from 25 cm depth and crushed sand filters presents COD and BOD₅ concentrations close to the required discharge limits. Therefore, for security reasons it is recommended to use deeper filters (i.e. 40 cm). The SS concentrations in the filters' outlet are very low, confirming the capability of ISFs to retain algae. ISFs also nitrifies the pond effluent, with TKN concentrations <7 mg/L and N-NH₄ concentrations ≤3mg/L for almost all the filters. The TP ISFs outlet concentrations ranged from 1,9 to 3,4 mg/L. Retention of phosphorus is comparable with the one from systems with fixed-biomass on fine media in the absence of specific material for phosphorus removal. In one year the removals diminished drastically for all filters (i.e. from 80% to 20 % for planted-filters). A significant retention would require the installation of specific materials (Molle *et al.*, 2003). During the whole study the average FC concentrations in the outlet of all filters was higher than 1000 CFU/100 mL (Table 5). However, it has been observed that the effluent quality of the 65 cm beds complies with the WHO guidelines for agricultural reuse and can be used for unrestricted irrigation in warm periods.

Table 3. ISFs performance (physicochemical parameters): average outlet pollutant concentration (standard deviation) and % removal

	M65		R65		C65		M25		R25		C25	
	mg/L	%	mg/L	%	mg/L	%	mg/L	%	mg/L	%	mg/L	%
COD	57.7 (15)	62	59.3 (18)	57	76.4 (19)	49	79.0 (16)	44	79.8 (18)	42	96.9 (17)	35
dCOD	45.0 (19)	52	49.1 (21)	47	67.1 (18)	27	53.8 (16)	42	55.3 (17)	35	69.2 (15)	23
BOD ₅	6.2 (2.5)	89	7.9 (3.5)	86	17.0 (4.1)	70	13.5 (4.2)	76	13.6 (5.7)	76	18.1 (6.2)	68
SS	9.8 (6.3)	78	11.5 (5.9)	75	19.7 (11)	69	17.1 (8.6)	63	17.8 (8.2)	69	26.3 (10)	52
TKN	4.9 (4.1)	78	4.3 (3.9)	79	6.7 (3.9)	70	6.9 (5.4)	69	6.5 (4.1)	70	8.7 (5.5)	63
N-NH ₄	1.7 (3.7)	92	1.6 (2.6)	92	4.0 (3.1)	73	3.0 (4.3)	82	2.7 (4.2)	83	4.3 (4.5)	71
N-NO ₃	10.4 (6.3)	*	14.3 (11)	*	11.5 (6.4)	*	11.1 (4.8)	*	14.3 (8.8)	*	11.3 (7.8)	*
TP	1.9 (1.2)	52	3.0 (1.2)	35	3.3 (0.5)	10	2.8 (1.1)	27	3.0 (0.8)	9	3.4 (0.3)	2

*ISFs Inlet N-NO₃ concentrations <0.5 mg/L; M65 (river-sand with macrophytes 65 cm), R65 (river-sand 65 cm), C65 (crushed-sand 65 cm), M25 (river-sand with macrophytes 25 cm), R25 (river -sand 25 cm), C25 (crushed-sand 25 cm)

Table 4. ISFs performance (microbiological parameters): average outlet pollutant concentration and Ulog removal

	M65		R65		C65		M25		R25		C25	
	CFU/ 100mL	Ulog	CFU/ 100mL	Ulog	CFU/ 100mL	Ulog	CFU/ 100mL	Ulog	CFU/ 100mL	Ulog	CFU/ 100mL	Ulog
FC	1.6e ³	1.55	1.2e ³	1.62	1.2e ³	1.64	1.3e ⁴	0.54	5.6e ³	0.91	8.7e ³	0.72
<i>E. coli</i>	1.2e ³	1.47	9.7e ²	1.49	8.1e ²	1.58	7.2e ³	0.62	4.6e ³	0.82	6.2e ³	0.69

The 65 cm filters show better performances for all physicochemical parameters, in particular for the removal of organic matter. In relation to bacterial indicators, the filters with 65 cm remove about 1.6 Ulog for FC and 1.5 Ulog for *E. coli*. Similar reductions were found by Arias *et al.* (2003) with 80 cm high Intermittent Vertical Flow Wetlands. Nevertheless, the removal for the shallow filters was lower than 1 Ulog. Hydraulic residence time is a key parameter in filter's disinfection capacity (Brissaud, 1999). The short HRTs of the shallow beds (Meauxsoone, 2004) may not allow better disinfection performances. Filters with crushed sand performed worse than the filters with river sand for organic matter (COD, dCOD, BOD₅) and SS removal. The use of crushed sand is not to discard but requests a higher security margin when dimensioning. The presence of reeds had notable effects in COD, dCOD and SS removal for HLs <50 cm/d. However, planted and non-planted river sand filters presented similar reductions for higher HLs. In general, the increase of hydraulic load (HL) reduced the removal efficiency of ISFs: an important decrease on COD, SS and TKN removals was observed when doubling the HL (Figure 5).

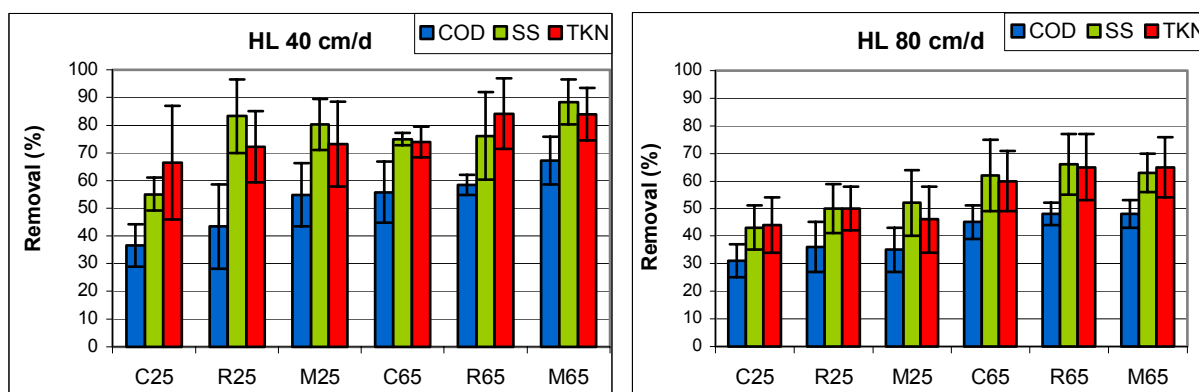

Figure 5. COD, SS and TKN removal for hydraulic loads of 40 cm/d and 80 cm/d

Operation and maintenance

The maintenance of the plant was simple but needed to be regular. The good performances achieved in this WWTP could be obtained by keeping strictly the alternate feeding of the filters (twice a week for the ISFs and once a week for the SDRBs). One of the main problems when working with algae influents is the risk of clogging the filters. The respect of the periods of feeding and rest is of major importance for the hydraulic reliability of the filters. The alternation of periods of rest and feeding regulates the growth of biomass and the formation of surface deposits, thus minimizing the risks of clogging. At the time, and respecting the operation mode of 3-4 days feeding and 7 days of rest for each filter, no problems of clogging appeared with hydraulic and organic loads of 80 cm/day and 180 g/COD/m² respectively. On the other hand, continuous feeding (> 8 days spreading) or too short periods of rest (3-4 days), leads to a weak mineralization of the surface deposits composed of algae. These conditions can diminish infiltration rates depending on the algae population (i.e. *Scenedesmus*) thus inducing the clogging of filters, particularly in winter. If surface clogging appears, the removal of this surface layer is necessary to restore the infiltration capacity. However, for planted filters the manual elimination of this layer is not possible. In that case specific hydraulic loads have to be applied until the clogging disappears by itself. When working with planted ISFs at the beginning of winter every year the faded aerial part of the reeds was cut and removed from the beds. Non-planted ISFs didn't need this maintenance activity. On the contrary, the maintenance operations during the study were more frequent and complicated due to the continuous growing of weeds in the beds. Generally, the use of planted-ISFs is recommended.

CONCLUSIONS

The association of a WSP with ISFs is a good solution for the treatment of rainwater and wastewater in small-size communities with combined sewerage systems. The results confirm the capacity of the system to withstand high flow variations thanks to the pond; thus maintaining an

excellent and constant effluent quality all year round thanks to the ISFs.

The setting up of a Settler Tank combined with Sludge Dewatering Reed Beds upstream the pond resulted in a simple and effective option to diminish the SS load (50 %) arriving to the WSP; thus improving the aerobic state of the lagoon, enhancing the WSP performances and theoretically reducing to half the frequency of desludging.

The WSP performed consistently well for the removal of all the contaminants. In spite of this, the WSP effluent didn't comply with the required French level to discharge in sensitive areas, confirming the need of additional treatments. The quality of the WSP effluent was not affected by rain episodes concerning the physicochemical parameters but presented a seasonal behavior.

The study has proved the capacity of ISFs to retain algae, complete organic matter degradation and achieve an excellent nitrification. The effluent of all tested filters complied with the required French quality level for sensitive bodies (<125 mg/L COD, <25 mg/L BOD₅), even with hydraulic loads of 80 cm/day. Moreover, the microbiological quality of the outlet complied with the WHO guidelines for reuse regarding FC for the filters of 65 cm during the warmer periods. The influence of the depth, the media type and the hydraulic loads on the filters performances has been stated.

For the studied conditions, the recommended configuration is: ST+WSP(6m²/PE)+ISF(1m²/PE). These dimensioning bases can be useful for the design of new WSPs allowing a reduction of the total necessary surface compared to the classical WSP configurations. The choice of the filter's depth and the type of sand will depend on each particular context. The use of planted-filters is recommended for maintenance reasons. The management of the plant remains simple but regular, and could be performed by non-skilled personnel.

ACKNOWLEDGEMENTS

This work has been carried out with the financial contribution of the European program LIFE Environment (LIFE02 ENV/F/000303–LILIPUB).

REFERENCES

- Abis, K.L. and D.D. Mara. (2003). Research on waste stabilisation ponds in the United Kingdom - initial results from pilot-scale facultative ponds. *Water Science and Technology*, **48**(2), 1-7.
- AFNOR (2005). Recueil Normes & Réglementation Environnement. Qualité de l'eau. Vol 1 and 2. France.
- Alcalde, L. G. Oron, L. Gillerman, M. Salgot and Y. Manor. (2003). Removal of fecal coliforms, somatic coliphages and F-specific bacteriophages in a stabilization pond and reservoir system in arid regions. *Water Supply*, **3**(4), 177-184.
- Arias, C.A. A. Cabello, H. Brix and N.H. Johansen (2003). Removal of indicator bacteria from municipal wastewater in an experimental two-stage vertical flow constructed wetland system. *Water Science and Technology*, **48**(5), 35-41.
- APHA (1998). Standard Methods for the examination of water and wastewater. 19th ed. American Public Health association, Washington DC.
- Boutin, C., A. Liénard, N. Billote and J.P. Naberac. (2002). Association of waste stabilization ponds and intermittent sand filters: the pilot results and the demonstration plant of Aurignac. Proceedings of the 8th International Conference on Wetland system for water pollution control, Arusha (Tanzania), 543-555.
- Brissaud, F. (1999). Wastewater treatment by infiltration-percolation (In Catalan). Water Resources. Salgot, M.; Sánchez, X. and A. Torrens (Eds), Spain, 222-242.
- Cavalcanti P., A. van Haandel and G. Lettinga. (2002). Sludge accumulation in polishing ponds treating anaerobically digested wastewater. *Water Science and Technology*, **45**(1), 75–81.
- Davis-Colley, R. J., Donnison, A. M., Speed, D., Ross, C.M. and Nagels, J. W. (1999). Inactivation of faecal indicator microorganisms in waste stabilization ponds: interactions of environmental factors with sunlight. *Water Research*, **33**(5), 1220-1230.
- Johnson M. and D.D. Mara (2005). Aerated rock filters for enhanced nitrogen and faecal coliform removal from facultative waste stabilization pond effluents. *Water Science and Technology*, **51**(12), 99-102.
- Kayser, K., Kunst S., Fehr G., Voermanek H., (2002). Nitrification in reed beds-capacity and potential control

- methods. *Water Science and Technology*, **46**(6-7), 363–370.
- Liénard, A., Guellaf H and Boutin C. (2001) Choice of the sand for sand filters used for secondary treatment of wastewater. *Water Science and Technology*, **44**(2-3), 189-196.
- Liénard, A., Boutin, C., Molle, P., Brissaud, F and B. Picot (2004). Proceedings of the 6th International Conference on Waste Stabilization Ponds and 6th Wetland system for water pollution control, Avignon (France), 13-22.
- Meauxsoone, D. (2004). In-situ comparison of the hydraulic behavior of Intermittent Sand Filters. (In French), Internal Report, CEMAGREF, 59 p.
- Middlebrooks, E. J. (1995). Upgrading pond effluents: an overview. *Water Science and Technology*, **31**(12), 353-368.
- Molle P., Liénard A., Grasmick A., Iwema A., and Kabbabi A. (2005). Apatite as an interesting seed to remove phosphorus from wastewater in constructed wetlands. *Water Science and Technology*, **51**(9), 193-203.
- Neder, K.D., G.A. Carneiro, T.R. Queiroz and M.A.A. de Souza (2002). Selection of natural treatment processes for algae removal from stabilisation ponds effluents in Brasilia, using multicriterion method. *Water Science and Technology*, **46**(4-5), 347-354.
- Pearson, H.W., Mara, D.D. and Bartone, C.R. (1987a). Guidelines for the minimum evaluation of the performance of full-scale waste stabilization ponds. *Water Research*, **21**(9), 1067-1075.
- Racault Y., Boutin C. (2005). Waste Stabilisation Ponds in France. State of the art and recent trends. *Water Science and Technology*, **51**(12), 1-9.
- Racault, Y. C. Boutin and A. Seguin. (1995). Waste stabilization ponds in France: a report on fifteen years experience. *Water Science and Technology*, **31**(12), 91-101.
- Sezerino, P.H., V. Reginatto, M. A. Santos, K. Kayser, L. S. Philippi and H. M. Soares. (2003). Nutrient removal from piggery effluent using vertical flow constructed wetlands in southern Brazil. *Water Science and Technology*, **48**(2), 129-135.
- WEF (1992). Design of Municipal Wastewater Treatment Plants, Vol. 2, Alexandria, VA.