



HAL
open science

Water Framework Directive Intercalibration Technical Report: Central Baltic Lake Phytoplankton ecological assessment methods

G. Phillips, G. Free, Y. Karottki, Christophe Laplace-Treyture, K. Maileht, U. Mischke, I. Ott, A. Pasztaleniec, R. Portielje, A. Pasztaleniec, et al.

► **To cite this version:**

G. Phillips, G. Free, Y. Karottki, Christophe Laplace-Treyture, K. Maileht, et al.. Water Framework Directive Intercalibration Technical Report: Central Baltic Lake Phytoplankton ecological assessment methods. Publications Office of the European Union, pp.184, 2014, Scientific and Technical Research series, 978-92-79-35463-2. 10.2788/73991 . hal-02599612

HAL Id: hal-02599612

<https://hal.inrae.fr/hal-02599612>

Submitted on 16 May 2020

HAL is a multi-disciplinary open access archive for the deposit and dissemination of scientific research documents, whether they are published or not. The documents may come from teaching and research institutions in France or abroad, or from public or private research centers.

L'archive ouverte pluridisciplinaire **HAL**, est destinée au dépôt et à la diffusion de documents scientifiques de niveau recherche, publiés ou non, émanant des établissements d'enseignement et de recherche français ou étrangers, des laboratoires publics ou privés.



J R C T E C H N I C A L R E P O R T S

Water Framework Directive Intercalibration Technical Report

Central Baltic Lake Phytoplankton
ecological assessment methods

Geoff Phillips, Gary Free, Ivan Karottki,
Christophe Laplace-Treyture, Kairi Maileht,
Ute Mischke, Ingmar Ott, Agnieszka Pasztaleniec,
Rob Portielje, Martin Søndergaard, Wayne Trodd,
Jeroen Van Wichelen

Edited by Sandra Poikane

2014

Report EUR 26508 EN

European Commission
Joint Research Centre
Institute for Environment and Sustainability

Contact information

Sandra Poikane

Address: Joint Research Centre, Via Enrico Fermi 2749, TP 46, 21027 Ispra (VA),
Italy

E-mail: sandra.poikane@jrc.ec.europa.eu

Tel.: +39 0332 78 9720

Fax: +39 0332 78 9352

<http://ies.jrc.ec.europa.eu/>

<http://www.jrc.ec.europa.eu/>

This publication is a Technical Report by the Joint Research Centre of the
European Commission.

Legal Notice

This publication is a Technical Report by the Joint Research Centre, the
European Commission's in-house science service.

It aims to provide evidence-based scientific support to the European policy-
making process. The scientific output expressed does not imply a policy
position of the European Commission. Neither the European Commission nor
any person acting on behalf of the Commission is responsible for the use which
might be made of this publication.

JRC88246

EUR 26508 EN

ISBN 978-92-79-35463-2

ISSN 1831-9424

doi: 10.2788/73991

Cover photo: Sandra Poikane

Luxembourg: Publications Office of the European Union, 2014

© European Union, 2014

Reproduction is authorised provided the source is acknowledged.

Printed in Ispra, Italy

Introduction

The European Water Framework Directive (WFD) requires the national classifications of good ecological status to be harmonised through an intercalibration exercise. In this exercise, significant differences in status classification among Member States are harmonized by comparing and, if necessary, adjusting the good status boundaries of the national assessment methods.

Intercalibration is performed for rivers, lakes, coastal and transitional waters, focusing on selected types of water bodies (intercalibration types), anthropogenic pressures and Biological Quality Elements. Intercalibration exercises were carried out in Geographical Intercalibration Groups - larger geographical units including Member States with similar water body types - and followed the procedure described in the WFD Common Implementation Strategy Guidance document on the intercalibration process (European Commission, 2011).

In a first phase, the intercalibration exercise started in 2003 and extended until 2008. The results from this exercise were agreed on by Member States and then published in a Commission Decision, consequently becoming legally binding (EC, 2008). A second intercalibration phase extended from 2009 to 2012, and the results from this exercise were agreed on by Member States and laid down in a new Commission Decision (EC, 2013) repealing the previous decision. Member States should apply the results of the intercalibration exercise to their national classification systems in order to set the boundaries between high and good status and between good and moderate status for all their national types.

Annex 1 to this Decision sets out the results of the intercalibration exercise for which intercalibration is successfully achieved, within the limits of what is technically feasible at this point in time. The Technical report on the Water Framework Directive intercalibration describes in detail how the intercalibration exercise has been carried out for the water categories and biological quality elements included in that Annex.

The Technical report is organized in volumes according to the water category (rivers, lakes, coastal and transitional waters), Biological Quality Element and Geographical Intercalibration group. This volume addresses the intercalibration of the Lake Central Baltic Phytoplankton ecological assessment methods.

Contents

1. Introduction.....	2
2. Description of national assessment methods.....	2
3. Results of WFD compliance checking.....	9
4. Results IC Feasibility checking.....	11
5. IC dataset collected.....	15
6. Common benchmarking.....	18
7. Comparison of methods and boundaries.....	22
8. Description of biological communities and changes along pressure gradient.....	30

Annexes

A. Phytoplankton classification systems of Member States.....	37
B. Evaluation of relationship between national methods and cyanobacteria biomass.....	98
C. Relationships between National EQRs and Pressure.....	110
D. A description of ecological class boundaries for phytoplankton as proposed by the Central Baltic GIG for lake types LCB-1 and 2.....	115
E. Common metric: Development and standardization.....	150
F. Relationship between MS metrics and Common Metric.....	176

1. Introduction

In the Central Baltic Phytoplankton Geographical Intercalibration Group (GIG):

- Initially, eleven Member States submitted their national lake assessment systems (France did not participate because did not share LCB1 and LCB2 types) ;
- All methods address eutrophication pressure and follow a similar assessment principle (including biomass metrics and species composition index);
- Intercalibration "Option 2" was used - indirect comparison of assessment methods using a common metric;
- IC common metric was developed specifically for this IC exercise comprising 2 metrics (chlorophyll-a and composition index PTI), it was benchmark-standardized using "continuous benchmarking" approach;
- The comparability analysis showed that boundary bias in several cases exceed 0.25 class limit, therefore DK, PL, NL and UK revised their assessment systems and modified boundary values;
- LV and LT methods were not included in the final results as their boundaries exceed 0.25 bias and there was no agreement to modify these boundaries;
- The final results include EQRs of lake phytoplankton assessment systems of Belgium (Flanders), Germany, Denmark, Estonia, Ireland, Netherlands, Poland and UK for 2 common lake types: LCB1 and LCB2.

2. Description of national assessment methods

In the Central Baltic Phytoplankton GIG, ten countries participated in the intercalibration with finalised phytoplankton lake assessment methods (Table 2.1, detailed description in Annex A).

Table 2.1 Overview of Central Baltic GIG lake phytoplankton assessment methods

MS	Method	Status
BE-FL	Flemish phytoplankton assessment method for lakes	Finalized formally agreed national method
DE	PSI (Phyto-Seen-Index)	Finalized but not formally agreed national method
DK	Danish Phytoplankton Index	Intercalibration-ready finalized method
EE	Assessment of status of lakes on the basis of phytoplankton	Finalized but not formally agreed national method
FR	Lake phytoplankton index: IPLAC	Finalized but not formally agreed national method (but not included within CBGIG IC)
IE	IE Lake Phytoplankton Index	Finalized but not formally agreed national method
LT	Lithuanian assessment method of lakes	Intercalibration-ready finalized method

MS	Method	Status
LV	Latvian assessment method of lakes	Intercalibration-ready finalized method
NL	WFD- metrics for natural watertypes	Finalized but not formally agreed national method
PL	Phytoplankton Metric for Polish Lakes (PMPL)	Finalized but not formally agreed national method
UK	Phytoplankton Lakes Assessment Tool (PLUTO)	Finalized but not formally agreed national method

2.1. Required BQE parameters

Based on the information below (see Table 2.2), the GIG considers that all methods cover the parameters needed to be indicative of the Phytoplankton BQE as a whole.

Table 2.2 Overview of the metrics included in the national phytoplankton assessment methods

	Abundance	Taxonomic composition
BE_FL	Chlorophyll a	% cyanobacteria
DE	Chlorophyll a mean and max Total biomass	Algal class metric PTSI (indicator taxa system)
DK	Chlorophyll a	% Cyanobacteria % Chyrsophytes Difference between number of sensitive and tolerant taxa
EE	Chlorophyll a	PP compound quotient (PCQ) PP community description (PCD) Pielou index of evenness (J')
IE	Chlorophyll a : MBA	Taxonomic composition: MCS
GE	Chlorophyll a	Irish Phytoplankton composition and abundance Index Score for indicator taxa and summer chlorophyll-a
LT	Chlorophyll a mean and max 1b) total biomass	% Bacillariophyta plus Chyrsophyta % Cyanobacteria
LV	Chlorophyll a	PP compound quotient (PCQ) PP community description (PCD) Pielou index of evenness (J')
NL	Chlorophyll a	Multimetric species composition
PL	Biomass of phytoplankton Chlorophyll a	Relative biomass of Cyanoprokaryota
UK	Chlorophyll a	Taxonomic Composition PTI Biomass Cyanobacteria

The normative definitions require that assessment is made of taxonomic composition and abundance, biomass and the frequency and intensity of planktonic blooms:

1. Biomass - all countries meet this requirement. All countries assessment systems include parameters which are indicative of phytoplankton biomass. This is generally assessed using chlorophyll a, which is a valid and accepted surrogate of biomass. Some countries, as DE, PL, and LT, also include a direct measure of total biomass derived from cell volume and counts.
2. Taxonomic composition and abundance – all countries have a metric which includes an assessment of taxonomic composition and abundance. Some countries (PL and BE) only consider cyanobacteria. Others (DK, IE, LT, LV, EE, NL, and UK) include metrics which relate to selected taxa or taxa grouped by class, including cyanobacteria. A few countries (DE, and UK) include weighted average metrics which take information from species or genera covering the full planktonic community.
3. Intensity and frequency of blooms.

The GIG had long discussions about the requirement for a bloom metric and reached the conclusion :

- That the member state metrics were generally highly correlated with the abundance of cyanobacteria and thus would adequately detect the presence of abnormal growth of cyanobacteria (Annex B of this report);
- This was particularly clear for metrics which use taxonomic indicator scores of various types as shown in the paper provided by Germany (Annex B) and Ireland (Annex B)
- A similar analysis using the GIG data set for LCB1 and LCB2 lakes has demonstrated that all national methods show significant positive relationships between the final EQR and cyanobacteria biomass (
- Table 2.3);
- In addition Denmark provided a paper (Annex B) setting out the view that the cyanobacteria metric is relatively variable with poor correlations with pressure (TP);
- The WISER data also show this lack of correlation with pressure, what those data demonstrated, was that as pressure increases (TP) then there was a greater probability of elevated cyanobacteria abundance, but there were also many data points at high TP with very low cyanobacteria.

The question then arises as to whether a lake with elevated TP, probably elevated phytoplankton biomass (Chl-a), but with few cyanobacteria should have a higher status than a similar lake with cyanobacteria. Should the absence of cyanobacteria allow the final EQR of a combined metric to increase, as this would be the consequence of including a simple cyanobacteria metric using an average. After discussion in the NGIG the UK reached the conclusion that this should not happen and thus used a more complex

combination rule, which only included the cyanobacteria EQR if it was less than the average of the taxonomic and biomass metric.

Table 2.3 Coefficient of determination (adjusted r²) for relationship between national final EQR and cyanobacteria biovolume for common types LCB1 and LCB2.

Country	Adjusted r ²	
	LCB1	LCB2
Common Metric	0.415	0.317
UK	0.299	0.475
DE	0.541	0.622
EE	0.248	0.434
LV	0.339	0.370
BE	0.585	0.669
NL	0.290	0.271
LT	0.197	0.222
PL	0.653	0.702
IE	0.383	0.426
DK	0.527	0.584

Thus, while the directive states that bloom abundance and frequency should be included, it is clear that it can introduce greater uncertainty into the final metric. The GIG position that the MS methods would detect abnormal increases in cyanobacteria biomass and thus do not specifically require a separate bloom metric.

Further details of GIG analysis, and submissions from DE, IE and DK are given in Annex B:

- DE - Position paper on bloom metric from Germany;
- IE - The applicability of existing IE phytoplankton metrics in reflecting blooms ;
- DK - The use of cyanobacteria in the ecological classification of lakes.

Combination rules

All MS provide clear information on combination rules (see Annex A). A variety of combination rules are used by MS, averaging, weighted averaging, worst of some metrics. Specific combination rules have not been considered as the GIG will compare the final metrics during the intercalibration process.

When combining metrics all countries (except LT) normalise their metric EQR prior to combination. The GIG note that LT method does not carry out this step and thus there is an assumption in the method that the metric EQRs are on the same scale. However, as the metric EQR boundaries are not identical this assumption is not valid. However, this issue would only be a significant concern if a pseudo-common metric was used for the

intercalibration process and thus the LT method has been compared using the independent biological common metric

2.2. Sampling and data processing

There are variations in sampling procedures which will contribute to differences between methods. Different definitions of growing season make it difficult to apply all MS methods to all data. For example, countries which assess taxonomic composition over full growing season, cannot be applied to those that only assess status in late summer. Benchmark standardization may compensate for these effects but because sampling methods are not always sufficiently comparable "Option 2" is used for comparison.

In space (sampling depth and sampling stations):

- Most countries sample phytoplankton in pelagial of lakes in epilimnion or euphotic zone at deepest point (DE, DK, FR, LT, IE, and PL), except EE (whole water column), IE (surface), LV (sampling in lake midpoint), UK (with shore side or outlet sampling);
- DE, LT and other MS use more sampling points in large lakes. In BE-FL regular multi-point sampling is carried out across entire surface of epilimnion-metalimnion (stratified lakes) or entire water column (shallow polymictic lakes).

In time (period and frequency is critical because of seasonal plankton succession):

- summer all countries:
- monthly in vegetation season: BE-FL (6-8x), DE (6-9x), DK (7-19x), EE (4x), FR (4x/year with 3/growing season), LT (2- 9x), LV (2-4x), IE (2x taxonomic composition, 4-12x for chl-a), PL (3x), NL (6-7x); UK (12x for chl-a; 3x taxonomic composition, assessed over a 3 year period).

Although the data available to the GIG is sufficient to make comparisons of the national classification systems, the frequency of sampling for some countries is not likely to be sufficient to provide an adequate assessment of biomass and the frequency of cyanobacteria blooms.

The GIG dataset only contains a small number of lakes with data from several years and thus it is not possible to provide a robust analysis of temporal variation. However, analysis shows that temporal variability of all methods is relatively low (standard deviation for national metrics: FR - 0.08, IE - 0.04, PL - 0.08, LT - 0.06, NL - 0.05, BE - 0.07, LV - 0.04, EE - 0.04, DE - 0.07, Common metrics - 0.07).

About the UK sampling method (question was raised whether it significantly differs from other MS sampling approaches):

- Structured sampling exercise was carried out in order to investigate sources of variability in each of the UK phytoplankton metrics.

-
- It shows that there is no significant difference between the metric results obtained by sampling different areas of the open water, including a depth integrated sample of the epilimnion with those obtained from outflow and edge using a throw bottle.
 - The analysis also highlighted the importance of seasonality, with month of sampling having a very significant influence on the variation of the mean growing season chlorophyll value. Thus collecting 12 monthly samples is extremely important in determining the true mean phytoplankton biomass. It would be practically impossible to take monthly samples from all the lakes we currently classify if we had to collect open water samples and to move to this method would result in a substantial reduction in the sampling frequency, which would greatly increase the level of uncertainty of the final metric;
 - Given that we have demonstrated that outflow samples are not significantly different to those collected from the open water we feel our current sampling strategy provides the optimum approach to reducing uncertainty.

2.3. National reference conditions

The general issue in CBGIG is the lack of true reference lakes. As a result all countries have used combinations of expert judgement, models and where available reference lakes to determine reference conditions (see in detail Annex A).

2.4. National boundary setting

The majority of countries have set boundaries or EQRs for chlorophyll that are the same or only slightly different to the values agreed during phase 1 Intercalibration (see Poikane 2008).

Boundaries for chlorophyll set by LT have been clarified. The boundaries used are significantly lower than those agreed for phase 1 for LCB2 lakes and slightly lower for LCB1.

IE also use reference chlorophyll that is lower than that agreed in phase 1 for LCB2. IE have provided alternative classifications which use the GIG minimum chlorophyll reference value and this will be used when determining the harmonisation band for the GIG.

In general there is insufficient detailed information to evaluate the boundary setting protocol for other metrics, but all countries appear to have relied on a significant amount of expert judgement.

Table 2.4 Overview of the methodology used to derive ecological class boundaries

MS	Conclusion on compliance	Boundary setting procedure
BE-FL	Compliant	Chlorophyll boundaries match IC phase 1. % Cyanobacteria boundaries based on expert judgment
DK	Compliant	Chlorophyll boundaries match IC phase 1. EQR values taken from values agreed for phase 1 intercalibration. Taxonomic metric boundaries are based on distribution of species along a pressure gradient of TP. Final selection of taxa based on expert judgement.
EE	Compliant	Chlorophyll GM EQR boundary very slightly higher than values agreed in IC phase 1. Estonian phytoplankton method uses pressure response relationship. Phytoplankton scores vs. land-use index reveals model describability r^2 0.53. Boundary setting procedure uses expert judgement, palaeolimnological data, historical records and information from reference sites.
FR	Compliant	Chlorophyll boundary EQR values vary with mean depth of the lake. And for lakes with depth >3m are within range agreed in phase 1. Chlorophyll HG boundary for lakes with depth <3m is lower than value agreed for phase 1. Boundaries for both Chlorophyll (biomass MBA) and species composition metric (MCS) defined from pressure response relationship with equal size status class for log total phosphorus
DE	Compliant	Chlorophyll boundary values fall within range agreed for phase 1. Boundaries for other metrics derived from pressure response relationships using German LAWA and Total P index, supported by expert judgement.
IE	Compliant, although LCB2 chlorophyll boundaries are tighter than used for phase 1	Chlorophyll boundary EQR values for LCB1 taken from values agreed for phase 1. Boundary for LCB2 based on expert judgement and is lower than the range agreed in phase 1. Boundary for IPI metric derived from discontinuity in relationship between pressure and biological response.
LT	Compliant	Chlorophyll boundary values significantly lower than values agreed for LCB2 lakes and slightly lower for LCB1 lakes. EQR for combined chlorophyll mean and max metric lower than those agreed for mean chlorophyll a in phase 1. Boundaries derived by equal division along EQR gradient for chlorophyll and taxonomic metrics
LV	Compliant	Chlorophyll boundary values fall within range agreed for phase 1. Boundaries for other metrics derived from EE method
NL	Compliant	Chlorophyll boundary values taken from values agreed in phase 1 intercalibration. Taxonomic boundaries based on expert judgement.
PL	Compliant	Chlorophyll boundary values fall within range agreed for phase 1. Boundaries for total biomass and cyanobacteria biomass derived from classifications based on chlorophyll.

MS	Conclusion on compliance	Boundary setting procedure
UK	Compliant	Chlorophyll boundary EQR values taken from values agreed for phase 1 intercalibration. Boundaries for PTI metric based on the proportion of sensitive and tolerant taxa combined with expert judgement. Boundaries for cyanobacteria biomass metric based on risk that WHO bloom risk threshold is exceeded

3. Results of WFD compliance checking

The GIG considers all countries cover the parameters needed to be indicative of the BQE as a whole and MS methods are considered sufficiently good to go forward with comparisons

The table below lists the criteria from the IC guidance and compliance checking conclusions

Table 3.1 List of the WFD compliance criteria and the WFD compliance checking process and results

Compliance criteria	Compliance checking conclusions
1. Ecological status is classified by one of five classes (high, good, moderate, poor and bad).	Yes for all countries
2. High, good and moderate ecological status are set in line with the WFD's normative definitions (Boundary setting procedure)	See above
3. All relevant parameters indicative of the biological quality element are covered (see Table 1 in the IC Guidance). A combination rule to combine parameter assessment into BQE assessment has to be defined. If parameters are missing, Member States need to demonstrate that the method is sufficiently indicative of the status of the QE as a whole.	Yes, see above
4. Assessment is adapted to intercalibration common types that are defined in line with the typological requirements of the	<p>See details at Feasibility checking – Typology Summary</p> <p>The GIG lead considers that the majority of issues with LCB1 and LCB2 lake types have been overcome. The main remaining issue with typology</p>

Compliance criteria	Compliance checking conclusions
WFD Annex II and approved by WG ECOSTAT	for CBGIG is the diversity of lake types found within the LCB3 lake type. Further evaluation of LCB3 lakes has revealed that the lake type is too diverse to allow a successful intercalibration. There are too few lakes of a similar alkalinity and depth to create further sub-types and thus the GIG conclude that it is not possible to intercalibrate the L-CB3 type.
5. The water body is assessed against type-specific near-natural reference conditions	See above.
6. Assessment results are expressed as EQRs	All countries except EE express their results as an EQR. The EE metric could be converted to an EQR, but for the purpose of boundary comparison it has been left as the index value.
7. Sampling procedure allows for representative information about water body quality/ ecological status in space and time	See above
8. All data relevant for assessing the biological parameters specified in the WFD's normative definitions are covered by the sampling procedure	Yes
9. Selected taxonomic level achieves adequate confidence and precision in classification	Countries have provided phytoplankton data at a variety of taxonomic levels. These data were extensively checked during the construction of the GIG database and as far as possible taxa names were harmonized. These data were then combined with data from other GIGs as part of the WISER project and subsequent analysis has been carried out using the WISER database. These data are considered a very comprehensive checked data set and while there remain some issues which limit the application of some MS methods to all the data they are adequate for the purpose of intercalibration. As it is not always possible to apply all MS methods to other countries and as a result the GIG is relying on option 2 for comparison. For example the EE method requires a more detailed taxonomic level and size categories than is available in the GIG database and can thus only be applied to EE lakes.

4. Results IC Feasibility checking

4.1. Typology

The Intercalibration is feasible for L-CB1 and L-CB2. Following initial comparison the GIG conclude it is not possible to compare L-CB3 lakes (see Tables below).

Table 4.1 Description of common intercalibration water body types and list of the MS sharing each type

Common IC type	Type characteristics	MS sharing IC common type
LCB1	Lowland, stratified, shallow calcareous, retention time 1-10 years	BE-FL – stratified; DK- yes; DE – yes; EE – yes; FR – no ; LT – yes, no information concerning stratification available; LV – yes, no information concerning stratification available (expert judgement only); IE - yes but may not be stratified; NL – yes; PL – stratified; UK - yes but may not be stratified
LCB2	Lowland, very shallow calcareous, retention time 1-12 months	BE-FL – yes; DK – yes; DE – yes; EE – yes; FR – no ; LT – yes; LV – yes; IE – yes; NL – yes; PL – polymictic; UK – yes
LCB3	Lowland, shallow, siliceous, vegetation dominated by Lobelia, retention time 1-10 years	BE-FL – yes; DK - yes (mostly very shallow); DE - no ; EE - yes; FR - yes; LA - no ; LV – yes; IE – no ; NL – no; PL – 26 lakes of this type, but not included in the IC process as not sufficiently common; UK – no but similar type in NGIG

Table 4.2 Evaluation if IC feasibility regarding common IC types

Country		Details
BE	Y	Type specific EQR boundaries for GIG types LCB1, LCB2 and LCB3 provided
DK	Y	Type specific EQR boundaries for chlorophyll for GIG types LCB1, LCB2 and LCB3 provided.
EE	Y	Type specific EQR boundaries for GIG types LCB1, LCB2 and LCB3 provided
FR	Y	FR typology does not consider alkalinity. However FR macro type for one metric BA1 (very shallow lowland) matched to LCB2 and BA2 (shallow lowland) matched to LCB1 and EQR boundaries provided.
DE	Y	DE typology has been matched to GIG types. DE types 10 & 13 matched to LCB1, DE type 11.2 matched to LCB2. These are all lowland, high alkalinity lakes of the correct depth. Very shallow lakes are polymictic, shallow lakes are stratified and all have volume to catchment area ratio of >1.5 and thus have retention times of 3-30 days.

DK	Y	DK lakes are allocated to GIG types. All LCB1 lakes are assumed to be stratified
IE	Y	IE typology is not directly matched to GIG types, but is based on the same parameters Alkalinity and depth. However lakes that fall within the GIG typology and Type specific EQR boundaries for GIG types LCB1, LCB2 are provided.
LT	Y	LT national typology only splits lakes by mean depth. The LT depth boundaries are at 3m, 9m and 15m. For LCB2 lakes the LT boundary EQRs clearly match the IC type, but for LCB1 lakes 2 sets of boundaries will need to be compared.
LV	Y	LV national typology also include colour. However as LV EQR boundaries are the same for all lake types they can be applied to the GIG lake types without difficulty. LV type 6 matched to LCB3 lakes – needs to be checked by LV experts. (GIG now conclude that LCB3 cannot be intercalibrated)
NL	Y	Type specific EQR boundaries for GIG types LCB1, LCB2 and LCB3 provided
PL	Y	PL lake typology does not include alkalinity, but is split by depth and water retention time. PL have applied their metric to CBGIG lake types according to the PL typology
UK	Y	UK lake types are the same as the GIG types

Table 4.3 Evaluation of IC feasibility regarding common IC types – summary. (Y – intercalibration feasible, N – intercalibration is not feasible).

Method	Appropriate for IC types/subtypes	Remarks
Method BE-FL	LCB1	Y
	LCB2	Y
	LCB3	Lakes allocated to LCB3 are much smaller than those from FR and EE. They may thus not be sufficiently comparable
Method DE	LCB1	Y but only stratified once
	LCB2	Y
	LCB3	N
Method DK	LCB1	Y
	LCB2	Y
	LCB3	N
Method EE	LCB1	Y
	LCB2	Y
	LCB3	N
Method FR	LCB3	N
Method LT	LCB1	Y
	LCB2	Y
	LCB3	N
Method LV	LCB1	Y

Method	Appropriate for IC types/subtypes	Remarks
	LCB2	Y
	LCB3	N
Method IE	LCB1	Y
	LCB2	Y
	LCB3	N - IE does not have type
Method NL	LCB1	Y
	LCB2	Y
	LCB3	N - NL does not have type
Method PL	LCB1	Y
	LCB2	Y
	LCB3	N -PL does not have sufficient lakes of this type
Method UK	LCB1	Y
	LCB2	Y
	LCB3	N - UK does not have type

4.2. Pressures addressed

The Intercalibration feasible in terms of pressures addressed by the methods as all methods assess eutrophication. The GIG dataset has been used to provide an independent test of the relationship between the final EQR and pressure, using mean growing season total phosphorus and nitrogen. Scatter plots are shown in Annex C and details of the resulting regression parameters are shown in Table 4.4. All countries except LT have significant relationships.

Table 4.4 Linear regression between national EQR and a mean growing season total phosphorus (Log10) for TP <200µgP/ l-1 and mean growing season total nitrogen (log10) for TN <5.0 mg TN/ l.

Country	L-CB1 Lakes Total P					L-CB1 Lakes Total N				
	intercept	slope	R ²	P	df	intercept	slope	R ²	P	df
BE	1.339	-0.465	0.335	<0.001	351	0.615	-0.378	0.15	<0.001	199
DE	1.242	-0.417	0.381	<0.001	179	0.617	-0.337	0.273	<0.001	120
DK	1.274	-0.476	0.450	<0.001	462	0.552	-0.344	0.179	<0.001	304
EE	-0.555	1.863	0.273	0.018	18			0.053	0.169	18
IE	1.257	-0.448	0.447	<0.001	249	0.545	-0.468	0.319	<0.001	
LT			0.002	ns	21			0.014	0.26	21
LV	1.122	-0.263	0.512	<0.001	460	0.705	-0.169	0.142	<0.001	312
NL	1.38	-0.517	0.497	<0.001	471	0.555	-0.462	0.267	<0.001	320
PL	1.392	-0.445	0.337	<0.001	270	0.679	-0.47	0.209	<0.001	154
UK	1.646	-0.63	0.552	<0.001	486	0.662	-0.542	0.299	<0.001	321
CM	1.655	-0.602	0.512	<0.001	486	0.695	-0.511	0.269	<0.001	321

Country	L-CB2 Lakes Total P					L-CB2 Lakes Total N				
	intercept	slope	R ²	P	df	intercept	slope	R ²	P	df
BE	1.259	-0.385	0.225	<0.001	182	0.636	-0.544	0.194	<0.001	143
DE	1.395	-0.447	0.342	<0.001	56	0.649	-0.716	0.594	<0.001	47
DK	1.139	-0.339	0.409	<0.001	269	0.608	-0.472	0.280	<0.001	250
EE	0.15	1.249	0.425	0.007	25			-0.033	0.64	25
IE	1.347	-0.545	0.522	<0.001	100	0.435	-0.565	0.336	<0.001	75
LT			0.071	ns	6	0.642	-1.341	0.485	0.03	6
LV	1.107	-0.23	0.451	<0.001	287	0.739	-0.358	0.332	<0.001	271
NL	1.365	-0.431	0.422	<0.001	297	0.669	-0.665	0.329	<0.001	285
PL	1.389	-0.436	0.321	<0.001	141	0.709	-0.613	0.268	<0.001	123
UK	2.048	-0.779	0.565	<0.001	287	0.818	-0.945	0.302	<0.001	271
CM	2.174	-0.826	0.561	<0.001	287	0.859	-1.067	0.32	<0.001	271

4.3. Assessment concept

Intercalibration is feasible for assessment concept as:

- All MS include chlorophyll a in their methods, but with varying definitions of the growing season. This was discussed and accepted during phase 1 as representing different climatic conditions so this should not be a problem;
- All MS include a taxonomic component:
 - For DE this includes a weighted average type metric which describes community composition;
 - FR use a weighted average between metrics;
 - EE, LV, LT & IE include simpler community composition metric;
 - BE-FL, LV, PL & UK focus on abundance of cyanobacteria;
 - EE & LV include metrics which consider evenness of the community;
 - NL includes presence of blooms for selected algal groups;
 - UK & IE do not have phytoplankton data for spring/early summer and those MS where these data are essential will not be able to classify sites from UK & IE.

Table 4.5 Evaluation of IC feasibility regarding assessment concepts.

Method	Assessment concept	Remarks
Method BE-FL	Chlorophyll a % cyanobacteria	Growing season May – Oct, Requires phytoplankton data for full growing season. boundaries for % cyanobacteria too stringent if applied to summer data cannot be compared with UK and IE data
Method DE	Chlorophyll a mean and max Total biomass Algal class metric PTSI	Growing season April – Oct Requires phytoplankton data for full growing season, may not be comparable with UK & IE data
Method DK	Chlorophyll a Taxonomic Index considering the % of algal class, and the difference of number of sensitive and tolerant taxa	Growing season March - Sept
Method EE	Chlorophyll a PP compound quotient PP community description Pielou index of evenness	Growing season May - Sept Estonian method includes metrics which describe the evenness of the community (as a diversity index) in addition to taxonomic composition. This may result in low levels of comparability with countries who do not include this aspect of the community.

Method FR	MBA (total biomass metric) Chlorophyll a MCS (species composition metric)	Growing season May – Oct .
Method LT	Chlorophyll a % Bacillariophyta & Chrysophyta % Cyanobacteria	Growing season Mar-Nov Mar-May Aug-Sept
Method LV	Adapted from EE Chlorophyll a PP compound quotient PP community description Pielou index of evenness	Growing season May - Sept
Method IE	Chlorophyll a Composition (9 taxa) and Abundance Index (includes summer sample chlorophyll a within index)	Jan-Dec June-Sept
Method NL	Chlorophyll a Bloom metric	Growing season April - Sept
Method PL	Chlorophyll a Biomass of phytoplankton Biomass of Cyanobacteria	Growing season March – Oct July-Sept
Method UK	Chlorophyll a Taxonomic Index Plankton Trophic Index Biomass of Cyanobacteria	Jan-Dec July-Sept July-Sept

In conclusion:

- Due to potential difficulties in applying MS method to all data sets “Option 2” where MS method is applied to its own water bodies and compared to a biological common metric will be used as the primary method of comparison;
- Where there are too few lakes in a country, MS methods will also be applied to other MS data and compared with a biological common metric.

5. IC dataset collected

Huge dataset was collected within the Central Baltic Phytoplankton GIG - 254 lake-years LCB1 type (from 8 MS) and 274 LCB2 lake-years (9 MS) (table 5.1.)

Table 5.1 Overview of the Central Baltic GIG phytoplankton IC dataset.

Member State	Number of lake (waterbody) years					
	Biological data		Physico- chemical data		Pressure data	
	Any month	Min of May-Aug	Chl-a any month	Chl-a min of May-Aug	TP any month	T P min of May-Aug
	LCB1 type					
MS BE-FL	10	8	8	6	7	5
MS DE	224	223	224	223	220	220
MS DK	28	28	26	26	27	27
MS EE	33	33	33	33	32	32
MS FR						
MS IE	38	32	40	39	39	36
MS LT	38	37	37	36	37	36
MS LV	60	60	60	60	58	58
MS NL	17	17	17	17	17	17
MS PL	48	47	48	48	48	48
MS UK	51	47	90	79	84	72
	LCB2 type					
MS BE-FL	18	17	14	13	11	11
MS DE	62	62	62	62	62	62
MS DK	70	69	68	68	68	68
MS EE	22	22	22	22	22	22
MS FR						
MS IE	15	12	17	16	17	16
MS LT	14	14	13	13	13	13
MS LV	59	59	54	54	57	57
MS NL	33	33	33	33	33	33
MS PL	6	6	6	6	6	6
MS UK	78	47	108	103	84	79

Table 5.2 The data acceptance criteria used for the data quality control.

Data acceptance criteria	Data acceptance checking	
The sampling and analytical methodology	MS BE-FL	Whole water column sampled or epilimnion
	MS DE	Whole water column sampled or epilimnion or euphotic zone in clear water lakes
All MS counting methods are similar, 2 broad sampling methods used. Will need to test to see if the difference in sample method is significant for metric comparison.	MS DK	Whole water column sampled or epilimnion
	MS EE	Whole water column sampled or epilimnion
	MS FR	Euphotic zone sampled
	MS IE	Sub-surface sample
	MS LT	Sub-surface sample
	MS LV	Sub-surface sample
	MS NL	Sub-surface sample
	MS PL	Whole water column sampled or epilimnion (spring time euphotic zone for stratified lakes)
	MS UK	Sub-surface sample
	Level of taxonomic precision required and taxalists with codes Taxa list in file CBGIG_taxa_14092010	MS BE
MS DE		
MS DK		All countries record data to at least genus in most cases and all countries record some data at species level. Data is considered sufficiently good to go forward with comparisons, but when MS methods are applied to other MS data the adequacy of taxon resolution will need to be considered.
MS EE		
MS FR		
MS IE		
MS LT		
MS LV		
MS NL		
MS PL		
MS UK		IE and NL only record data as cell counts. This may introduce additional uncertainty as transformation to biovolume is based on standard values.
The minimum number of sites / samples per 17intercalibration type		With the exception of LCB3 there are sufficient lake years for most countries to use option 2, where MS methods are only applied to their own lakes. Where this is not possible methods will also be applied to other MS lakes.
Sufficient covering of all relevant quality classes /type	Yes	

6. Common benchmarking

6.1. Common approach of benchmarking

The intercalibration dataset does contain reference sites assigned by the member states. However, their number is considered insufficient to be used (Table 6.1). Therefore the approach of using continuous benchmarking was used.

Where reference sites were identified reference criteria for phase 1 were used:

- No point sources in lake catchment that can discharge to lake or its tributaries;
- Catchment land use corresponds to at least 90% natural land cover;
- Population density <10 inhabitants / km².

Under certain conditions these criteria can be overruled by clear sound palaeolimnological evidence or where there are clearly no signs of disturbance to the phytoplankton community and the GIG common metric falls within the range of other GIG reference sites.

Table 6.1 Number of ref lake years in the Central Baltic GIG phytoplankton dataset

	LCB1 Ref Lake Years	LCB2 Ref Lake Years	LCB3 Ref Lake Years
MS BE			
MS DE	11		
MS DK			1
MS EE			4
MS FR			2
MS IE	10	1	
MS LT	8	1	
MS LV	19	2	8
MS NL	1		
MS PL	5		
MS UK	4	6	
total	58	10	15

It is possible to compare conditions in reference lakes for L-CB1 lakes. Mean chlorophyll-a concentration, total P and the common metric in reference lakes for L-CB1 lakes do not give any indication that reference conditions are substantially different among countries (Figure 6.1). The median TP concentration for reference LCB1 lakes was 18 µg/l, the lower 10th percentile was 11 µg/l and the upper 90th percentile was 30 µg/l. The 90th percentile of mean chlorophyll a values (lake years) for reference sites fall below the maximum HG boundary value agreed during phase 1. There are too few lakes to make these comparisons for LCB2 and LCB3 lakes.

There are too few reference lakes to make these comparisons for LCB2 and LCB3 lakes. Alternative benchmarking was not possible because of the wide range of pressure across

the GIG (see Figure 6.2) there was no range of phosphorus within which all countries would have sufficient lakes to provide a robust benchmark. Therefore continuous benchmarking was used, where country specific differences are estimated from a wider range of pressures using linear mixed models.

For continuous benchmarking all sites in the ranges of 5-100 µg TP/ l were used.

As continuous benchmarking was used for standardization, validation of sites is not required. However, to validate the common metric and to provide the biological descriptions required for Reference conditions and at G-M class boundaries:

- All lakes in the GIG data set were classified using the common metric with EQR boundaries based on the average of all countries national EQR boundaries transposed to the common metric scale;
- Using this classification, which represents a harmonised view of status by all countries in the GIG, an initial description of different status classes, including reference conditions is provided below;
- Further details of the approach are given in Annex E.

Alternative benchmarks were not used, but range of TP and TN in lakes classified using the mean of national EQR on the common metric scale are shown in Figure 6.3.

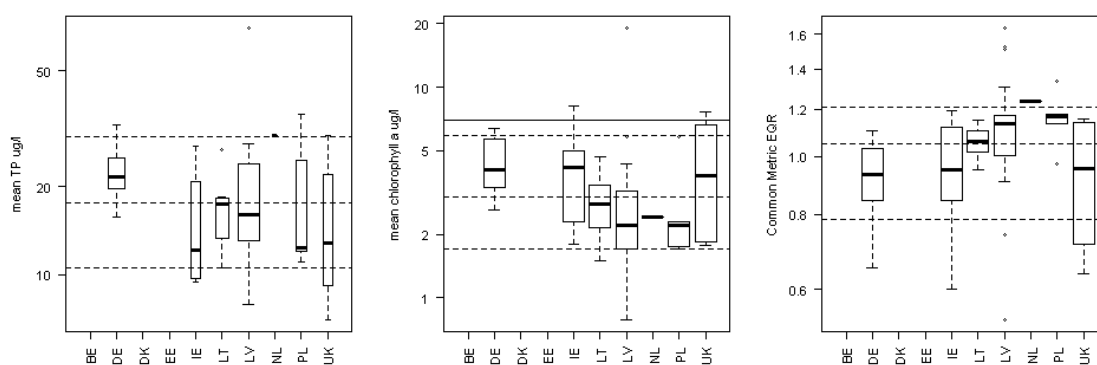

Figure 6.1 Distribution of mean TP, mean chlorophyll a, mean common metric EQR in L-CB1 reference lakes. Dotted lines are 10th, 50th, 90th percentiles, solid line in b is the maximum HG boundary value for chlorophyll a agreed in phase 1.

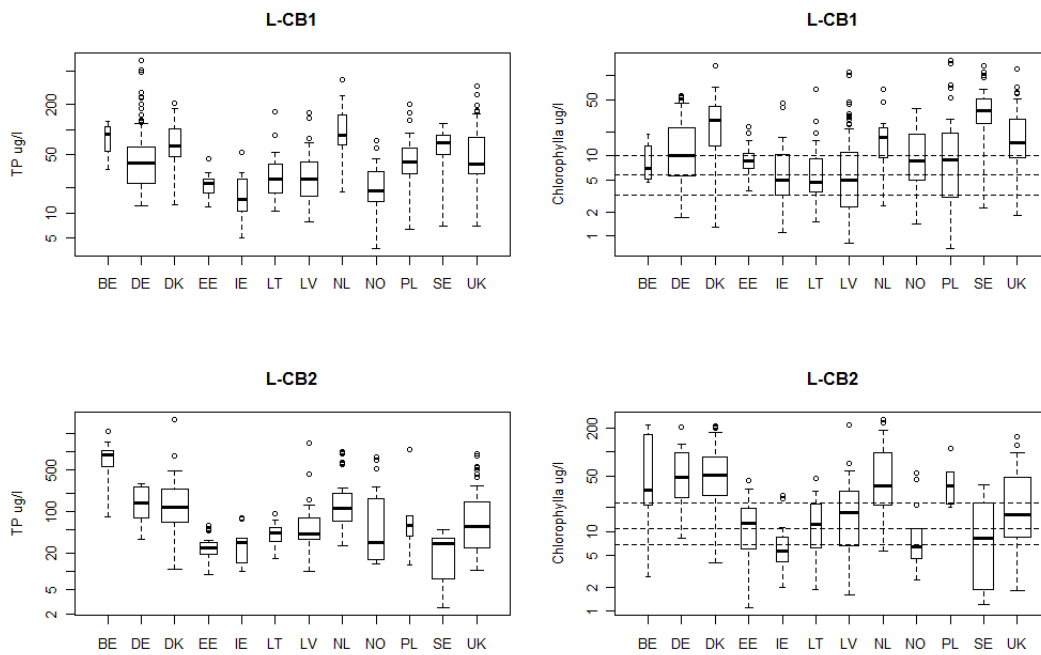

Figure 6.2 Range of total phosphorus and chlorophyll a growing season mean values for LCB1 and LCB2 lakes. (Horizontal lines mark reference, high good and good moderate boundary values for chlorophyll a agreed in phase 1)

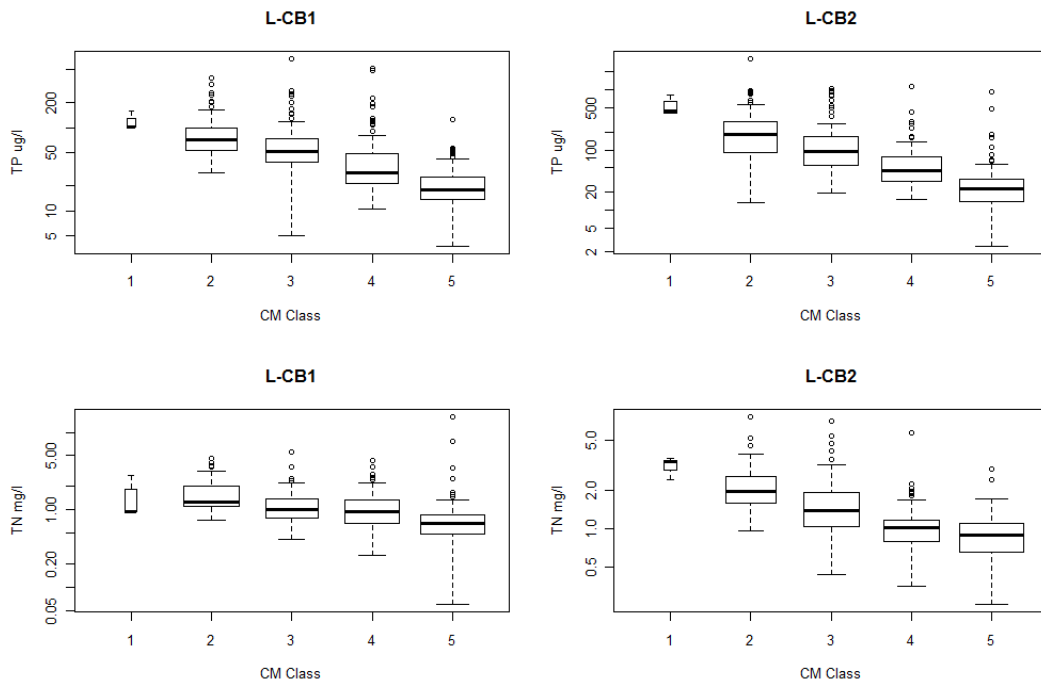

Figure 6.3 Range of mean growing season TP and TN in sites classified using the mean of national EQR on the common metric scale (1=Bad, 2= Poor, 3=Moderate, 4 = Good, 5= High) for LCB1 and LCB2 lakes. (Box width proportional to number of lake years)

6.2. Benchmark standardisation

The standardisation approach described in the IC Guidance requires adjustments to be made based on the median value of metrics in either reference or alternative benchmark sites. The method requires country specific off-sets to be identified which quantify country specific differences which are assumed to represent genuine differences between the metric that are caused by typological factors not removed by the simple GIG typology. Standardisation is then achieved by either subtraction or division depending on whether these differences remain or vanish with increasing pressure. A potential problem with this approach is that the differences are based on a relatively small number of lakes that are either at reference conditions or fall within the benchmark. Increasing the size of the benchmark with respect to pressure will increase the number of sites used, but will have the disadvantage that the sites being compared could be experiencing different levels of pressure. For the CBGIG no appropriate alternative benchmark could be identified within which a sufficient number of lakes from each country would occur.

For phytoplankton there is a strong relationship with TP, which is a good surrogate of pressure. Standardisation was applied to the taxonomic common metric (WISER PTI) to remove country effects using a mixed linear model where the PTI metric was the dependent variable, $\log_{10}TP$ was a co-variable and country was introduced as a random factor. The country factor can be allowed to influence both the slope and the intercept or only the intercept. For high alkalinity lakes testing identified that there was not a significant difference in the slope of the relationship between PTI and TP. Thus the model used to estimate country factors was only applied to the intercepts and the resulting random factors (country off-set) were subtracted from the PTI (Table 6.2).

No standardisation was carried out for the chlorophyll a metric used in the common metric as the same value was used for all countries.

Table 6.2 Country off-set values for WISER PTI metric

MS	Country Offset
BE	0.006
DE	0.143
DK	-0.107
EE	-0.154
IE	-0.019
LT	0.142
LV	0.102
NL	0.213
PL	0.175
UK	0.026

For "Option 2" standardisation of national metrics is not required. However, where a country did not have sufficient lakes to apply "Option 2", standardisation was carried out

in the same way. A linear mixed model was applied to the data with the National EQR as the dependent variable, logTP as the co-variable and country as a random factor. In this analysis an appropriate range of TP was used where the relationship was linear. Further details of the standardisation process are given in Annex F.

7. Comparison of methods and boundaries

IC Option and Common Metrics

Explanation for the choice of the IC option:

- Where there are sufficient lakes to produce statistically robust relationships option 2, with a biological common metric based on Chlorophyll a and the WISER PTI, was used.
- For PL and IE there were too few lakes in type L-CB2 to use this method, so the national metrics were applied to other MS data after benchmark standardisation (Option 3). This approach was also used to check BE relationship for L-CB1.

In case of IC Option 2, please explain the differences in data acquisition:

- Some MS (eg UK & IE) may have insufficient phytoplankton samples from spring and early summer to enable other MS to apply their methods.
- Some methods may be found to be insufficiently comparable in concept, for example one of the parameters used by EE and LV (evenness) is not included in other MS methods and additional information such as size categories are required.
- Differences in water column sampling will affect validity of MS boundaries.
- There remain significant issues with respect to taxonomy and the application of MS methods to the common database.
- Option 2 is thus considered to be the best approach, although where this is not possible for reasons explained above option 3 will be used.

IC common metrics

Describe the IC Common metric:

The IC common metric was the average of normalised Chlorophyll a EQR and country corrected PTI EQR.

- Chlorophyll-a EQRs are determined using the reference values agreed for each lake type in phase one. The resulting EQRs were converted to 0.8, 0.6, 0.4, 0.2 boundaries using piece-wise linear transformation of the boundary EQRs agreed for phase 1.
- The WISER PTI metric was standardised to remove significant country differences using linear regressions derived from linear mixed models with country as a

random factor. The median value of this standardised PTI from all reference lake years was used together with a fixed upper anchor to convert the PTI to an EQR which is independent of country. No attempt was made to determine a priori boundary values for the PTI EQRs and these EQR values are averaged with the transformed chlorophyll EQR.

It should be noted that when using an independent biological common metric it is possible that non-linear relationships will occur when making comparisons with the national metric EQRs. This will occur where a MS has non linear class intervals and as a result these relationships were examined for linearity. Consideration was also given to using other metrics, including total biomass and biomass of cyanobacteria, but these were rejected as they did not improve the performance of the common metric when judged by linear regression with Total P, a surrogate or pressure.

7.1. Results of the regression comparison

Member state EQRs were related to the biological common metric by linear regression. A summary of comparisons with the biological common metric for LCB1 and LCB2 lakes are shown below.

All regressions (except LT method for LCB1 type) met the intercalibration criteria:

- All relationships were highly significant $p \leq 0.001$ (except LT for LCB1);
- Common metric represented all methods ($r > 0.5$);
- All had significant slope parameters and the slopes were all within the range of 0.5 – 1.5 (note slope for EE appears outside this range as EE metric value rather than an EQR was used).

Option 2 was used for all countries, except for IE and PL on LCB2 lakes as there were too few lakes to produce a significant relationship. For these countries methods were standardised as necessary using mixed linear models and methods applied to all appropriate countries data (PL method was not applied to UK as UK data did not include spring and early summer samples).

LT method applied to L-CB1 lakes does not meet the requirement due to low correlation with the common metric. The LT **metric will not be used** to contribute to the GIG average boundary values on the common metric scale and the LT boundaries will not be compared until the metric correlation is improved by modifications to the LT metric.

All regression analysis was carried out using R. Full results from the regression analysis, together with scatter plots of the relationships between National Metric and Common metric are given in Annex F.

Table 7.1 Regression characteristics (National EQRs vs. Intercalibration Common Metrics).

Member State	L-CB1 type				L-CB2 type			
	Slope	r	r ²	P	Slope	R	r ²	P
BE	0.63	0.79	0.63	<0.001	0.99	0.97	0.93	<0.001
DE	0.87	0.79	0.63	<0.001	0.83	0.93	0.86	<0.001
DK	0.68	0.67	0.45	<0.001	0.75	0.65	0.43	<0.001
EE	0.23*	0.53	0.28	<0.001	-0.38*	0.85	0.73	<0.001
IE	0.90	0.80	0.64	<0.001	0.96	0.89	0.79	<0.001
LT		0.48		ns	0.57	0.76	0.89	<0.001
LV	1.49	0.69	0.47	<0.001	1.53	0.72	0.52	<0.001
NL	1.10	0.81	0.66	<0.001	1.09	0.69	0.46	<0.001
PL	0.80	0.89	0.80	<0.001	0.81	0.88	0.78	<0.001
UK	0.80	0.78	0.61	<0.001	1.09	0.85	0.73	<0.001

7.2. Evaluation of comparability criteria

Finally a class comparison was made by comparing the categorical classifications when each method was applied to as many countries as possible (Option 3).

1. The absolute class difference for both 5 and 3 classes (High, Good Moderate or worse) was calculated. In all cases the methods achieved the comparability criteria of <1.0 absolute class difference.
2. Boundary bias was calculated
 - For LCB1 lakes:
 - BE, DK and PL have boundary values that are >0.25 EQR units below the HG harmonisation band (boundaries too relaxed);
 - NL have boundary values >0.25 EQR units above the HG and GM harmonisation band (both boundaries too stringent):
 - For LCB2 lakes:
 - PL and LT have boundary values that are <0.25 EQR units below the HG harmonisation band (boundaries too relaxed);
 - LV has a GM boundary that is slightly below the GM harmonisation band (too relaxed);
 - DK and IE are above the harmonisation band for GM (boundaries too stringent).

Table 7.2 Overview of the IC comparability criteria

Member State	L-CB1 type			L-CB2 type		
	HG bias	GM bias	Avg class diff	HG bias	GM bias	Avg class diff
BE	-0.40	0.10	0.64	0.02	0.11	0.69
DE	0.16	0.24	0.65	-0.25	0.05	0.58
DK	-0.48	-0.11	0.75	-0.17	0.27	0.67
EE	0.02*	-0.17	0.54	0.21	-0.22	0.53
IE	0.17	0.21	0.62	0.24	0.36	0.74
LT	-	-	-	-0.30	-0.02	0.76
LV	0.21	-0.17	0.83	0.00	-0.29	0.91
NL	0.43	0.28	0.67	0.03	0.03	0.68
PL	-0.27	-0.09	0.69	-0.35	-0.01	0.62
UK	-0.14	-0.22	0.59	0.18	0.17	0.60

a) LCB1 type – HG boundary bias

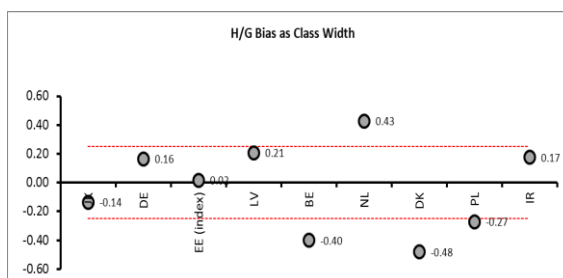

b) LCB1 type – GM boundary bias

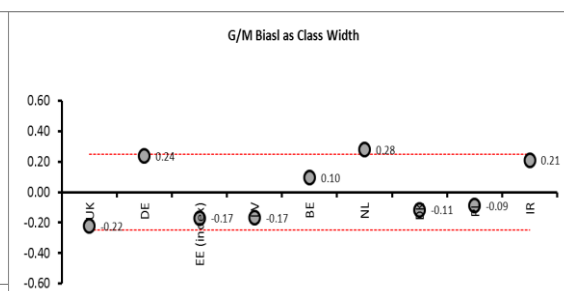

c) LCB2 type – HG boundary bias

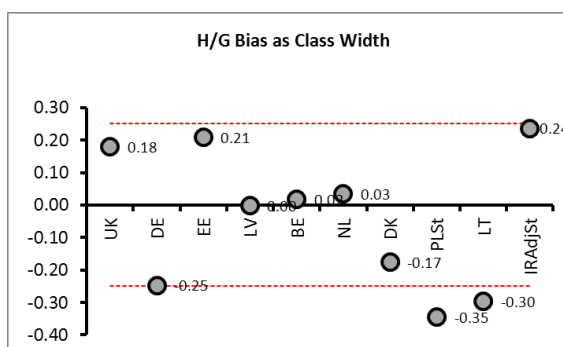

d) LCB2 type – GM boundary bias

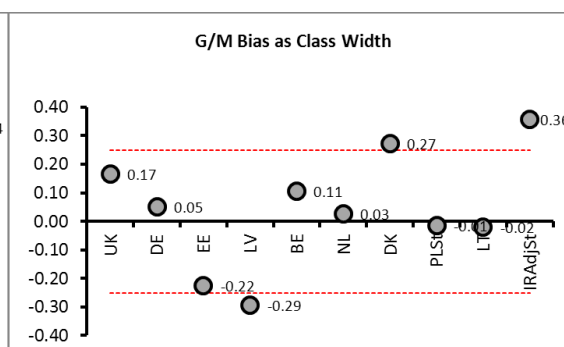

Figure 7.1 Comparison of Central Baltic GIG phytoplankton methods: HG and GM boundary biases (HG – High-Good class boundary, GM- Good-Moderate class boundary).

Boundary harmonisation can be achieved by modifying the national EQR values. However, for the majority of CB GIG countries (LT being an exception) the boundary EQR

values are an average of normalised metric EQRs. The most appropriate method of harmonisation thus requires a change in the value of the metric EQRs:

- To harmonise boundaries DK made changes to its metric, changing scores associated with the percentage of cyanobacteria, chrysophytes and the numbers of indicator species and modifying the relationship between total score and final EQR;
- PL made changes to boundaries for the cyanobacteria metric in non-stratified lakes to bring LCB2 lakes into the harmonisation band;
- UK made minor changes to boundary values for the taxonomic metric (PTI). This was required following changes made within the Northern GIG where the method is also applied.
- NL made changes to chlorophyll a boundary values for LCB1 lakes.

Harmonisation of MS boundaries for LCB1 lake type:

- Changes made by DK bring their method within the harmonisation band;
- Changes to combination rules made by UK following work in NGIG have only minor effects and both countries remain within the harmonisation band;
- No other changes to methods or boundaries were made, but a review of the regression relationships demonstrated that for LCB1 lakes the BE regression was significantly influenced by a single outlier, confirmed using jack knife regression which demonstrated uncertainty in the estimated slope of the relationship. Repeating the regression analysis with this outlier removed demonstrated that the BE HG boundary fell within the GIG harmonisation band. Confirmation of this was provided by applying the BE method to all LCB1 lakes. As a result the GIG concluded that the BE metric did not require further harmonisation.
- A similar review of the PL regression was carried out. This demonstrated that for PL a change in the slope of the regression of +0.005 would bring the PL metric within the band. This change is less than 10% of the standard error of the estimated slope (SE of slope ± 0.06) and given that the GM boundary for PL is within the harmonisation band the GIG conclude that there is not statistically significant evidence that PL need to modify their HG boundary EQR. However changes made by Poland to boundaries for non stratified lakes, which mainly apply to LCB2, resulted in a slight change to the relationship with the common metric for LCB1 as a few of this lake type were allocated to LCB1 during intercalibration and bring Poland within the harmonisation band.
- Further changes were made by NL in January 2012 to bring LCB1 lakes within the harmonisation band by adjusting boundary values for chlorophyll a. Boundary values were adjusted by a factor of 1.2, bringing the reference value to 3.8, the HG boundary to 7.0 and GM to 12.0, all within the range agreed by the GIG during the phase 1 intercalibration.

Harmonisation of MS boundaries for LCB2 lake type

- Changes made by DK and PL bring their methods within the harmonisation band;
- Changes made by UK to combination rules following work in NGIG result in an increase in the level of precaution which takes them above the harmonisation band;
- A review of the regression relationships for PL, LV and LT did not demonstrate that minor changes in slope could bring these countries within the harmonisation band. Changes to their boundaries are thus required.

The following countries currently remain outside the harmonisation band for LCB2

1. LV are below the harmonisation band for GM and LT are below the harmonisation band for HG (LV needs to change GM boundary to 0.62 and LT - HG boundary to 0.71);
2. IE boundaries are above the harmonisation band for both GM and HG boundaries. No change is proposed by IE as the lake type is considered more sensitive than other high alkalinity very shallow lakes in the CBGIG, as the lakes are typically found on limestone where deposits of CaCO₃ (marl) generate more oligotrophic conditions.
3. UK boundaries are above the harmonisation band for both HG and GM. No further boundary change is currently proposed by UK as its method needs to intercalibrate in both Northern and Central Baltic GIGs.

As experts from LV and LT have not been available it is unclear what changes these countries are able to make. For LV only a relatively small adjustment to the GM boundary is required, however for LT a more fundamental review of their method is required to achieve an adequate relationship with the common metric. **Therefore these methods were excluded from the final results.**

Table 7.3 Overview of the IC comparability criteria after harmonization of boundaries

Member State	L-CB1 type		L-CB2 type	
	HG bias	GM bias	HG bias	GM bias
BE	0.02	0.08	0.02	0.11
DE	0.17	0.24	-0.25	0.05
DK	-0.23	-0.11	0.00	0.09
EE	0.02*	-0.17	0.21	-0.22
IE	0.18	0.21	0.24/0.54	0.36/0.69
LT	-	-	-0.30	-0.02
LV	0.21	-0.17	0.00	-0.29
NL	0.25	0.13	0.03	0.03
PL	-0.21	-0.02	-0.15	0.16
UK	-0.02	-0.18	0.36	0.42

c) LCB1 type – HG boundary bias

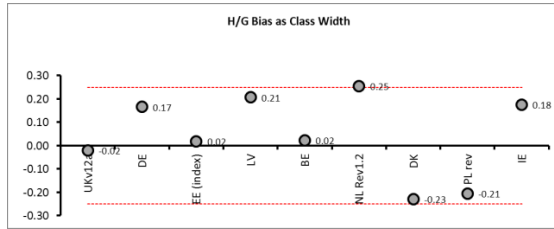

d) LCB1 type – GM boundary bias

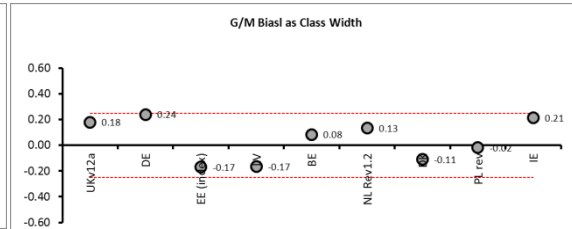

c) LCB2 type – HG boundary bias

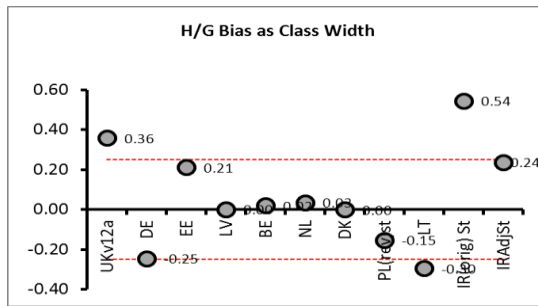

d) LCB2 type – GM boundary bias

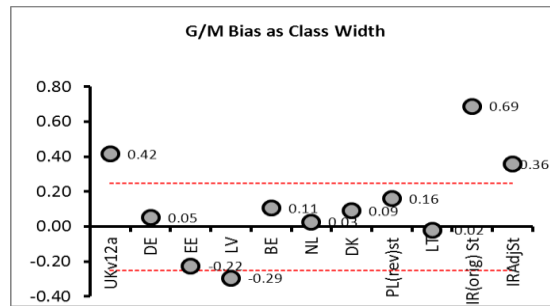

Figure 7.2 Comparison of Central Baltic GIG phytoplankton methods after harmonization of boundaries: HG and GM boundary biases (HG – High-Good class boundary, GM- Good-Moderate class boundary).

7.3. IC results

Table 7.4 Overview of the IC results: EQRs of the Central Baltic GIG phytoplankton assessment methods

	National classification systems intercalibrated	Ecological Quality Ratios	
		High-good boundary	Good-moderate boundary
Belgium (Flanders)	Flemish phytoplankton assessment method for lakes	0.80	0.60
Germany	PSI (Phyto-See-Index) - Bewertungsverfahren für Seen mittels Phytoplankton zur Umsetzung der EG-Wasserrahmenrichtlinie in Deutschland - German Phyto-Lake-Index (Phyto-See-Index)	0.80	0.60
Denmark	Danish Phytoplankton Index	0.80	0.60
Estonia	Estonian surface water ecological quality assessment – lake phytoplankton	0.80	0.60
Ireland	IE Lake Phytoplankton Index	0.80	0.60

Netherlands	WFD- metrics for natural watertypes	0.80	0.60
Poland	Phytoplankton method for Polish Lakes (PMPL)	0.80	0.60
United Kingdom	Phytoplankton Lakes Assessment Tool (PLUTO)	0.80	0.60

Table 7.5 Correspondence between common intercalibration types and national typologies/assessment systems

MS	LCB1 type	LCB2 type
BE	Type AWE, AWOM	Type AI Type AD Type AMI
DE	Type 13, Type 10.1	Type 11.2
DK	Type 10	Type9
EE	Type III	Type II
IE	All or part of Type7, Type 8, Type 11, Type 12	All or part of Type 5, Type 6, Type 9, Type 10
LT	Type II, Type III	Type I
LV	Type 5, Type 6	Type 1, Type 2
NL	M20, M21	M14, M27
PL	Part of 2a, 3a, 5a, 7a (only stratified with mean depth >3 m)	Part of 2b, 3b, 4, 5b, 6b, 7b (only non-stratified with mean depth <3 m)
UK	HAS : alkalinity > 0.1mEq/l, depth 3-15 m	HAVS alkalinity >0.1mEq/l, depth < 3m

7.4. Gaps of the current intercalibration

There are following gaps in the current intercalibration:

- LT method needs revision to achieve adequate relationship with Common Metric for LCB1 lake type;
- LV and LT need to consider how to harmonise boundaries;
- The GIG considers that in the future it would be useful to determine common phosphorus and nitrogen boundary values. These could be developed using the existing common data set, making use of the classifications of the common metric following harmonisation.

The comparison exercise has demonstrated the comparability of the existing national metrics, but the GIG consider that in the future it would be possible to combine the best metrics from each of the national and common metric to provide a single assessment system that could work across the whole of the GIG.

8. Description of biological communities and changes along pressure gradient

8.1. Description of the biological communities at reference SITES AND high status

At reference and high status the phytoplankton community is dominated by very sensitive taxa and contains relatively few very tolerant taxa (Figure 8.1). The phytoplankton community is diverse and dynamic, making descriptions of the community difficult, however after using all 3 indicator detection strategies (explained in section 8.2) the following very sensitive taxa should be (in descending order) characteristic in reference and high status lakes:

- **LCB1 ref and high status:** Dinobryon, Merismopedia tenuissima, Tabellaria, Kephyrion, Koliella, Tetraëdriella, Chroomonas, Achnanthes, Discostella glomerata and D. stelligera, Puncticulata praetemissa (Syn. Cyclotella praetemissa), Willea;
- **LCB2 at high status:** Botryococcus braunii, Discostella stelligera, Ankyra, Dinobryon, Uroglena, Raphidocelis, Mougeotia, Synura, Pseudopedinella

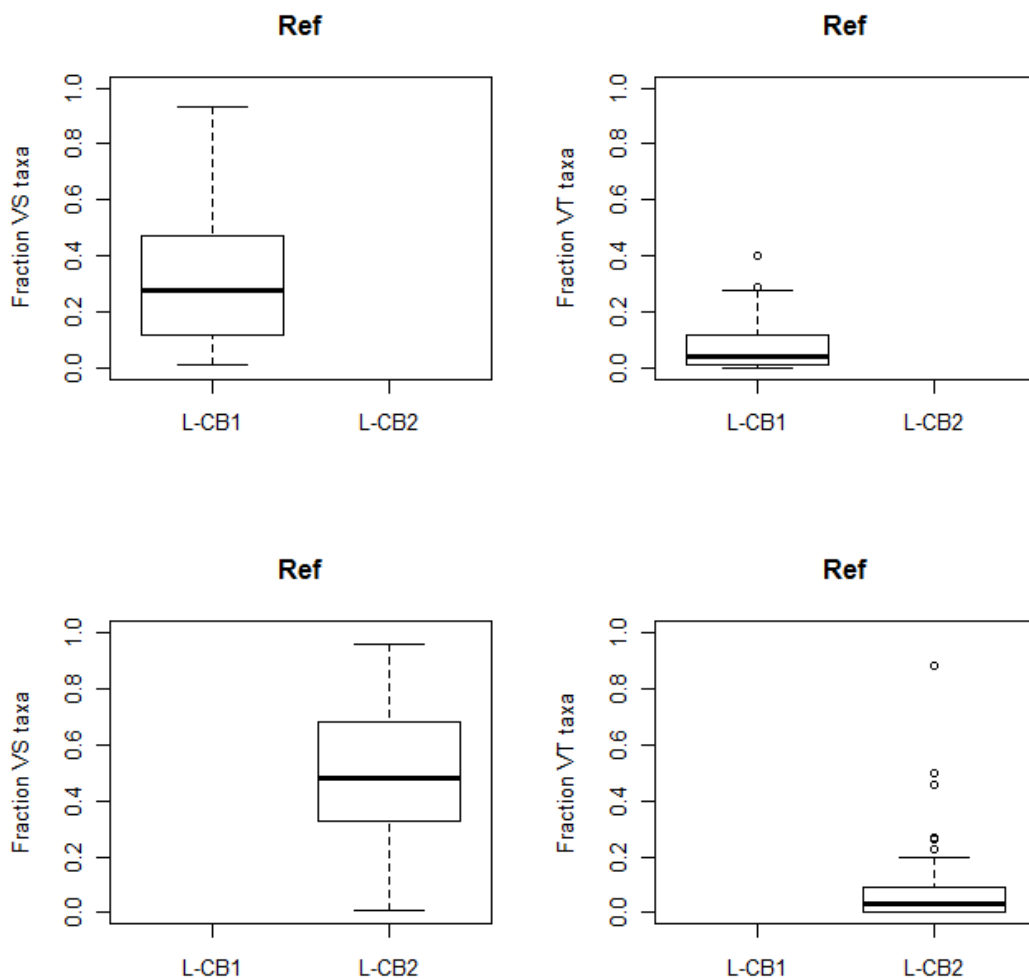

Figure 8.1 Range of Very Sensitive taxa and Very tolerant taxa in sites where Common Metric EQR > 1.00, potential Reference communities

8.2. Relationship of the biological common metric with pressure

With increasing pressure there is an increase in biomass of the phytoplankton for all lake types (Figure 8.3a), which is also reflected in an increase in chlorophyll a (Figure 8.4). There are also changes in the taxonomic composition, the biomass of diatoms and cyanobacteria increase with pressure (Figure 8.3b, Figure 8.3f). The biomass of chrysophytes, one of the sensitive taxa typical of reference conditions, decreases slightly but due to the increase in biomass of other algae their proportion decreases (Figure 8.3e). Thus these changes in community composition are a result of the increase in abundance of taxa able to respond to the increased availability of nutrients, rather than the direct loss of the more sensitive taxa.

Taxa were also split into 4 nutrient sensitivity classes (very sensitive, sensitive, tolerant, very tolerant) using the WISER PTI scores which reflect trophic status across the Northern and Central Baltic GIGs. PTI scores defining the sensitivity category boundaries were derived for each of the intercalibration typology alkalinity types. For CBGIG lakes the proportion of very sensitive, sensitive, tolerant and very tolerant taxa were determined for each lake class (Figure 8.2). There is a clear decrease of the proportion of very sensitive taxa as pressure increases and an increase in tolerant taxa. The most obvious changes are the increase in biomass of cyanobacteria with increased nutrient pressure.

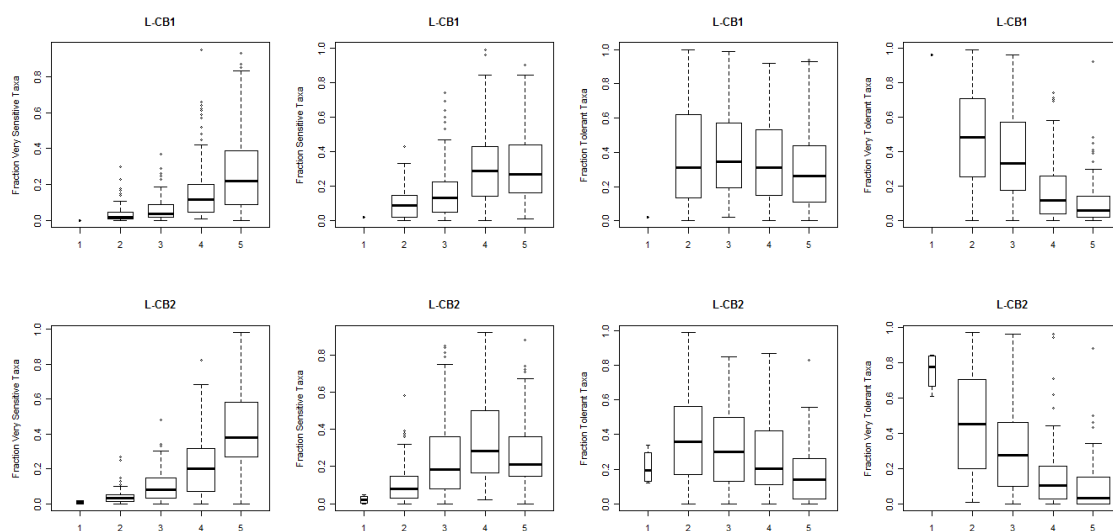

Figure 8.2 Proportion of a)very sensitive, b)sensitive, c)tolerant, d)very tolerant taxa for LCB1 and LCB2 lakes classified using the mean of national EQR on the common metric scale (1=Bad, 2= Poor, 3=Moderate, 4 = Good, 5= High

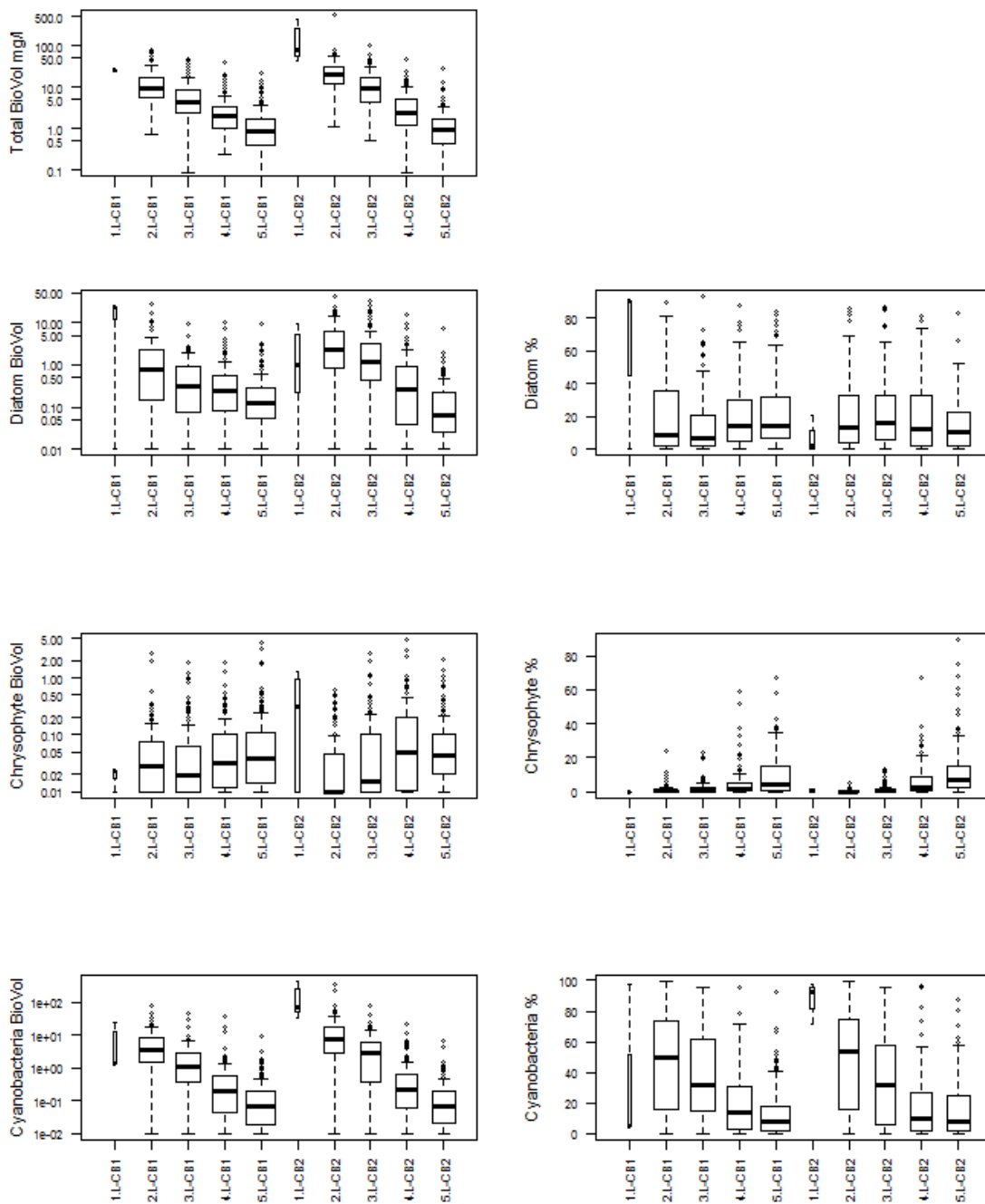

Figure 8.3 Relationship between a)total biomass, b) Diatom biomass, c)% Diatoms, d)Chrysophyte biomass, e) % Chrysophytes, f)Cyanobacteria biomass, e)% Cyanobacteria for LCB1 and LCB2 lakes classified using the mean of national EQRs on the common metric scale (1=Bad, 2= Poor, 3=Moderate, 4 = Good, 5= High

8.3. Comparison with WFD Annex V normative definitions

The normative definitions suggest that at the High-Good boundary there are only slight changes in the composition and abundance and that such changes do not give rise to undesirable disturbances to the balance of organisms present in the water body of the physico chemical conditions. Typical secondary changes might be a reduction in the maximum colonised depth of macrophytes in shallow lakes or their cover in very shallow lakes. In phase 1 of intercalibration the GIG focussed attention on changes in biomass, specifically the chlorophyll a metric. Evidence was presented that the HG boundary values would not impact on the macrophytes. Figure 8.4 demonstrates that the final HG boundary for the full phytoplankton assessment method is still consistent with these boundary values, with 75% of lakes classified as High having chlorophyll concentrations below the agreed HG boundary values.

At Good status taxonomic change is also relatively slight with the proportions of sensitive and very sensitive taxa remaining above 50%, only slightly lower than for High status sites.

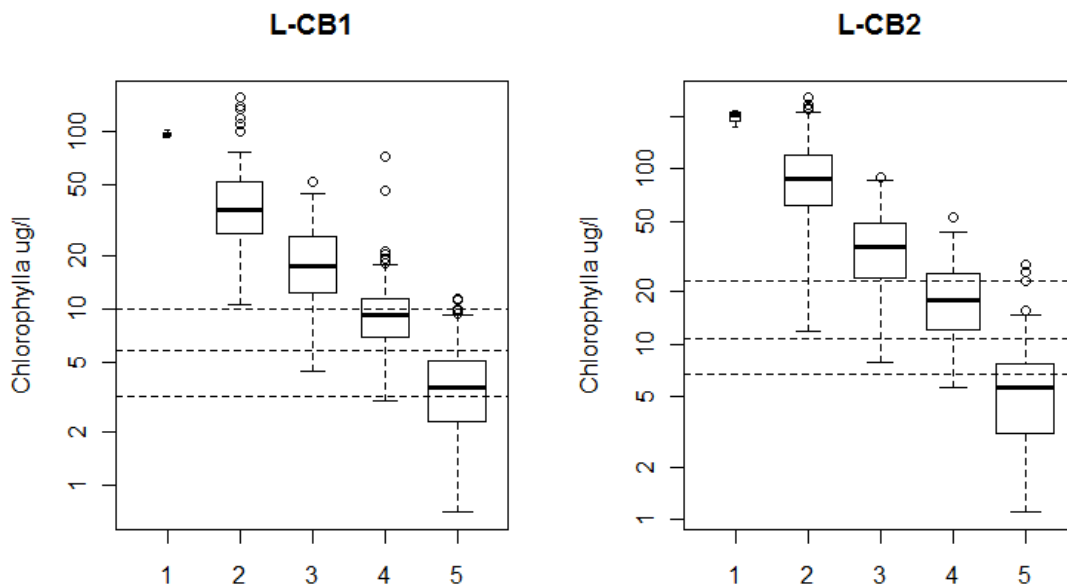

Figure 8.4 Mean growing season chlorophyll a concentration ($\mu\text{g l}^{-1}$) for LCB1 and LCB2 lakes classified using the mean of national EQR on the common metric scale (1=Bad, 2= Poor, 3=Moderate, 4 = Good, 5= High. (horizontal lines mark the boundary chlorophyll values agreed in phase 1, reference, HG and GM)

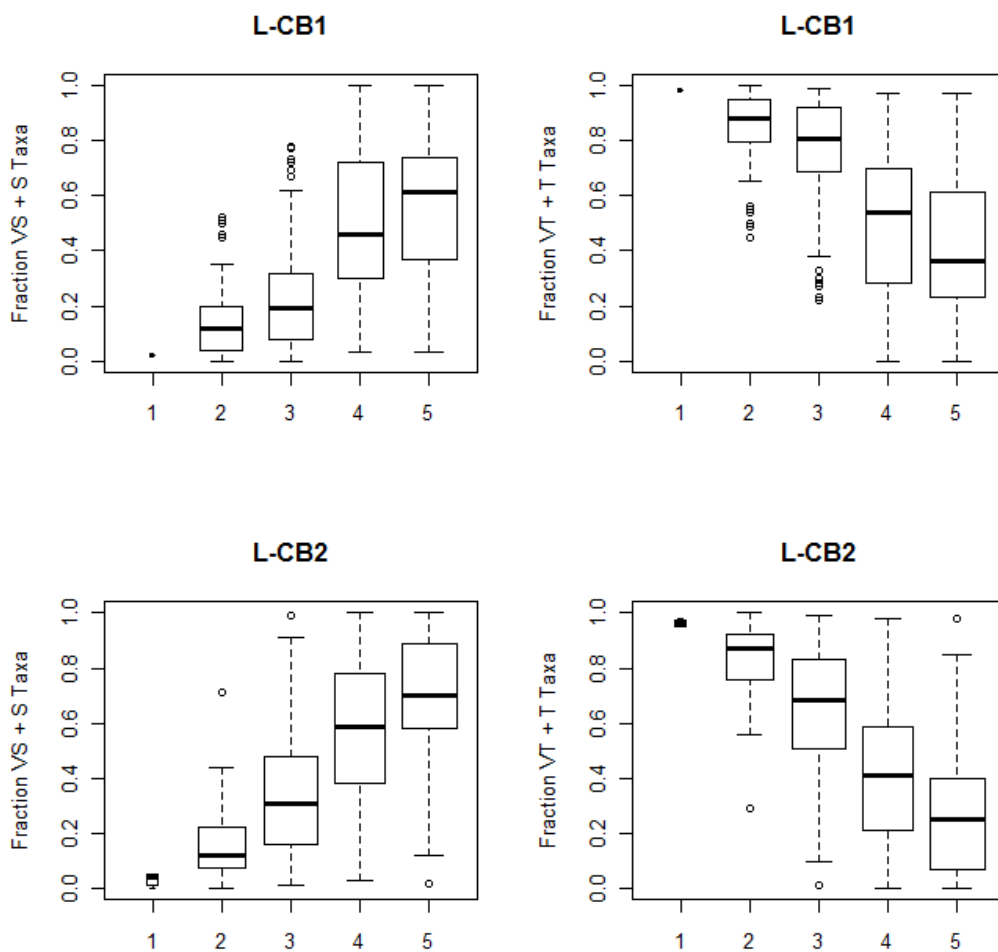

Figure 8.5 Proportion of a) very sensitive + sensitive, b) tolerant + very tolerant taxa for LCB1 and LCB2 lakes classified using the mean of national EQR on the common metric scale (1=Bad, 2= Poor, 3=Moderate, 4 = Good, 5= High)

The normative definitions also state that at Good status a slight increase in the frequency and intensity of planktonic blooms will occur. Frequency cannot be assessed from the GIG data, but there is only a slight increase in the abundance of cyanobacteria and the majority of lakes remain below the WHO low risk threshold for algal blooms (Figure 8.6). This contrasts with the situation in Moderate status where abundance has increased significantly.

The EU eutrophication guidance (EU 2009) provides further interpretation for Moderate and Poor status. For example taxa normally present at Reference conditions is in significant decline, while at Poor status they are rare or absent. The very sensitive taxa would be examples of such taxa and are clearly in significant decline by Moderate status and a very low proportion (<0.1) by Poor status (Figure 8.2a). Similarly tolerant and very tolerant taxa represent more than 50% of the community at Moderate status and over 80% at Poor.

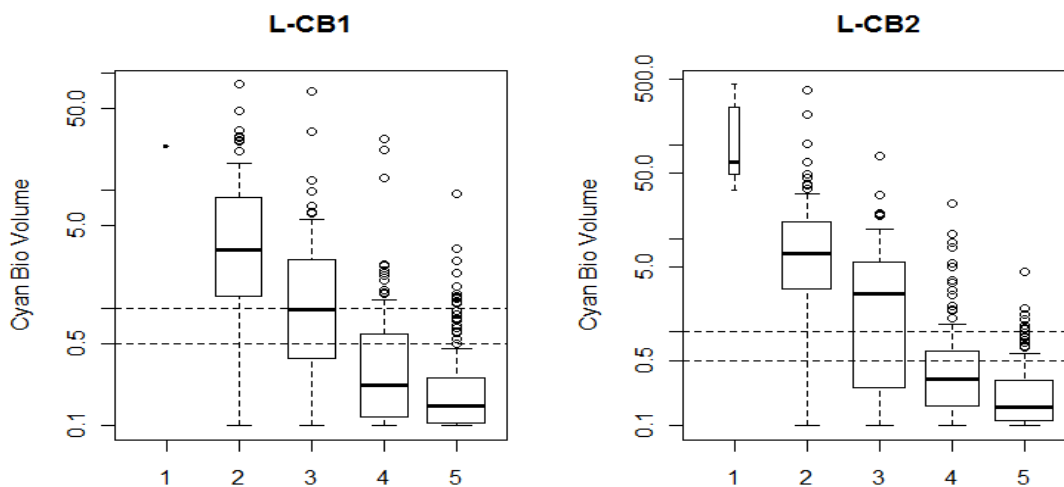

Figure 8.6 Biovolume (mg/l) taxa for LCB1 and LCB2 lakes classified using the mean of national EQR on the common metric scale (1=Bad, 2= Poor, 3=Moderate, 4 = Good, 5= High). Horizontal lines represent risk thresholds from WHO guidelines for low and high risk of blooms.

Further details of the development of the IC common metric are provided in Annex E.

8.4. Description of IC type-specific biological communities representing the “borderline” conditions between good and moderate ecological status

It is difficult to provide a clear description of the phytoplankton community at the borderline between good and moderate because this is a position on the nutrient gradient where lakes are likely to be undergoing significant change and as a result show significant change through time. In addition there are relatively few lakes at the borderline in the GIG data set.

In order to describe the biological communities at G/M three indicator detection strategies were combined:

1. The list of very sensitive taxa were checked (derived from taxa list of common metric; explanations see text above and Figure 8.2a);
2. The relative abundance and the relative frequency of taxa in selected lakes near the boundary were analyzed (see Annex D). Lakes were selected as groups that were within plus and minus 0.25 as a proportion of class width from the boundaries H/G, G/M, M/P and P/B, which were detected by the common metric scale derived from the mean of national MS method results;
3. Strategy 2 revealed genus taxa near the G/M boundary, which were cross checked with very sensitive taxa list from strategy 1. According this check in strategy 3

(expert check), several taxa had to be excluded from the borderline list because of opposite trend in distribution, when including all lakes (as in strategy 1) or because of being groups on order or class level, which functioning as collective taxa for all species not determined on species or genus level.

In result of all 3 strategies the following taxa should be in descending order frequent and characteristic near the G/M boundary and have its trophic optima below it:

- LCB1 G/M: *Gymnodinium*, *Elakatothrix*, *Botryococcus braunii*, *Chrysococcus*, *Uroglena*, *Urosolenia*, *Monoraphidium dybowskii*, *Aphanocapsa*, *Ankyra*, *Anabaena lemmermannii* group, *Quadrigula*, *Oocystis lacustris*, *Diatoma mesodon*;
- LCB2 G/M: *Kephyrion*, *Chrysochromulina*, *Monoraphidium*, *Chroomonas*, *Plagioselmis*, *Quadrigula*, *Mallomonas*, *Radiocystis*.

Annexes

A. Phytoplankton classification systems of Member States

A.1 Belgium (BE)

Sampling

In small lakes (<5 ha) water is collected in a large container from 8 random locations scattered across the lake using a boat. In large lakes (> 5 ha) 16 random sites are sampled.

In shallow lakes, it is sufficient to take each time a sample of the entire water with a tube sampler (a plastic 2-meter-long tube), ensuring that the soil and submerged vegetation is not touched to avoid contamination. One should also remain at a sufficient distance from the bank in order to avoid contamination with typical littoral species.

In deep lakes, at each point the entire circulating upper layer (epilimnion) is sampled. From the surface to the metalimnion, every meter, or every two meters in case of a very extensive epilimnion, a sample is taken using a Niskin bottle. The depth to which sampling should be done, is determined by the measurement of a vertical temperature and/or oxygen profile. When no data on the average depth of the lake is available, as many depth measurements as possible can be made during the transportation between two points. At a central point (or where the lake is at its deepest) using a multimeter the temperature, oxygen content, conductivity, acidity, the Secchi depth and ideally also the depth (in deep lakes) of the entire water column is measured with an interval of 50 cm. On the basis of the depth profile of the temperature, the thermocline to be determined up to where the biota should be sampled.

During transport between two points, the container should always be closed with a lid. After water is collected at all locations, subsamples are taken from the large container for microscopic and pigment analysis. The water should be thoroughly stirred in advance in order to homogenize floating organisms.

A 2-liter container is filled with water and stored in a cool box with cooling elements. When a lot of large zooplankton is present in the sample (especially in clear water with a dense macrophyte vegetation), the sample should be filtered in advance over a mesh size of 200 µm. This reduces the grazing of phytoplankton during the transport to the laboratory. If large colonies of blue-green algae are also present (*Microcystis*, *Aphanizomenon*, ...) this filtering should not be done.

The rest is filtered using a phytoplankton net of 10 µm mesh size and the concentrate is also stored cool in a 100 ml jar.

Conservation

A subsample of 250 ml for microscopic analysis is fixed with 125 µl alkaline lugol (dissolve 10 g of potassium iodide in 20 ml distilled water and add 5 g of iodide (solution A), dissolve 50 g of sodium acetate in 50 ml distilled water (solution B), bring the two solutions together), 6.25 ml formaldehyde buffered with borax (35 %) and 250 µl of

sodium thiosulphate (5 %) (Sherr & Sherr, 1993). These samples are stored in a cool, dark location.

For the analysis of chlorophyll a, a known volume of sample (depending on the amount of suspended material) is filtered under vacuum on a Whatman GF/F glass fiber filter (diameter 47 mm, pore size 0.7 µm) until the filter clogs. This filter is stored at – 80 °C until the analysis of chlorophyll a.

Identification

Microscopic analysis are conducted according to the European standard EN 15204:2006 (CEN, 2006). This is based on the classical Utermöhl method and counts of at least 400 units. This is carried out with sedimentation cuvettes and a reversed microscope after staining with Bengal Rose B to facilitate the detection of cells in detritus-rich samples (Utermöhl, 1958). The sample is moved up and down about twenty times to obtain a good homogenization before a subsample is placed in the sedimentation chamber using a (pipe-)pipette. For clear water, between 10 and 50 ml of sample is usually taken, for turbid water between 2 and 10 ml. The sedimentation time varies, depending on the amount of sample, between 6 hours (5 ml) and 24 hours (50 ml). The organisms are counted at different magnifications. Per sample, at least 400 individuals are identified, to the species level where possible (otherwise to genus level) in which colonies are regarded as an individual. The most common taxa are counted under a magnification of 400x by 1 or more longitudinal transects or in 50 to 100 random fields. For the dominant phytoplankton taxa at least 100 individuals should be counted and for less common taxa about 25 individuals. Larger organisms are counted at a lower magnification (100 - 200x) along longitudinal transects or in a half or an entire cuvette. For colonies, individual cells are counted or estimated or when this is not possible (colonial cyanobacteria) a density factor is determined. This shows how densely cells are aggregated within a colony (Table A.1), which is important for the conversion to biomass. If the cells are far apart and hence much open space is present within the colony, the density factor is low. Filaments are counted as individuals. Of each taxon a number of individuals is measured (length-width). Filaments are fully measured.

Table A.1 Target values for density estimation of colonial cyanobacteria

	Open colony	Dense colony
Chroococcales	0.05 – 0.07	0.07 – 0.1
<i>Microcystis</i>	0.3 – 0.6	0.6 – 0.8
Gomphosphaeroideae	0.3 – 0.6	0.6 – 0.8

Separate counts are also made for picocyanobacteria and floating cyanobacteria, which are largely missed using the ordinary Utermöhl technique. These data are added to the densities determined with the Utermöhl technique.

The quantification of picocyanobacteria (size: 0.2 – 2 µm) is done using epifluorescence microscopy. For this purpose, 5 ml of water per sample is concentrated on a black polycarbonate filter (Isopore GTBP, 0.22 µm pore). These filters are placed on a microscope slide and embedded in fluorescent oil (Cargile A), and subsequently stored in the freezer before the microscopic analysis. The counting is carried out with an epifluorescence microscope at a magnification of 1000x under green light, which makes the characteristic organisms strongly illuminate (autofluorescence). Complete fields are counted until 400 units are reached, or a total of 20 complete fields.

For quantification of floating cyanobacteria 1 ml of well homogenized sample is placed in a Sedgewick-Rafter counting chamber and after five minutes all floating organisms (just under the cover slip) in the counting chamber are quantified. In case of a too high density, only a few transects are counted.

With the average size for each species a biovolume is determined using geometric formulas (Tikkanen & Willen, 1992, Hillebrand et al, 1999) of the corresponding best fit forms (sphere, cylinder, ...). Biovolume is converted into C-biomass for each species using the following formulas (Menden-Deuer & Lessard, 2000):

$$\text{pg C (diatoms)} = 0.288 * (\text{biovolume } (\mu\text{m}^3))^{0.811}$$

$$\text{pg C (other phytoplankton)} = 0.216 * (\text{biovolume } (\mu\text{m}^3))^{0.939}$$

The density is obtained with the following formula:

$$\text{Density (N/ml)} = [(D / C) * B] / A$$

With: A: volume of the subsample

B: surface area of the cuvette

C: the surface area that was counted

D: the number of individuals that was counted for each species

The biomass is calculated as follows:

$$\text{Biomass } (\mu\text{g C/l}) = (\text{pg C/cell} * \text{density}) / 1000$$

The chlorophyll a is extracted from the filter with acetone (90 %). Subsequently, the concentration of chlorophyll a determined by spectrophotometer or HPLC.

Index calculation

The status determination for phytoplankton in lakes is done using the metrics biomass and species composition.

Metric biomass

The metric biomass is based on the chlorophyll a content. The measured value for this metric is converted into an EQR by dividing the reference value by the measured value. When the measured chlorophyll content is lower than the reference value, the EQR is set equal to 1.

The class limits high/good and good/moderate for chlorophyll a are determined in the framework of the intercalibration exercises (EU, 2008) for all types except Bzl. For this type Bzl values are provisionally taken from the Dutch type M30 (Van der Molen & Pot, 2007). The values for the lower class boundaries are provisionally derived using the proposed doubling per class. All these class boundaries are shown in Table A.2.

Table A.2 Chlorophyll-a criteria for a number of lake types. The high/good and good/moderate boundary values result from the European intercalibration (EU, 2008) with the exception of Bzl.

Type	Awe, Awom (LCB1)	Ai, Ad, Ami (LCB2)	Bzl	Cb, CFe, Czb (LCB3)	Zs, Zm
Class boundary	Chl _a (µg/L) – summer average				
Reference	3.2	7.4	30	3.1	3.1
Boundary high/good	5.8	11.7	40	5.4	5.4
Boundary good/moderate	10	25	60	10	10
Boundary moderate/poor	20	50	120	20	20
Boundary poor/bad	40	100	240	40	40

Metric species composition

For the metric species composition, the relative proportion of cyanobacteria expressed as biomass (%) is used. The division into status classes is applied according to Table A.3.

For species composition we preferred to use a very basic and simple metric for all water types, which is biomass contribution of harmful cyanobacteria during the growing season (April-October). We see this also as a bloom metric since it is able to capture (longer-lasting) blooms within our monthly sampling campaigns over the whole growing season. We were unable to find clear correlations between nutrients and dominance of cyanobacteria in the sparse amount of phytoplankton data we have for about 30 lakes in Flanders belonging to different WB-types. But we found relationships with macrophyte cover, which is a better indicator for ecosystem health in our many shallow freshwater lakes. The contribution of cyano's in lakes with a cover of more than 50 % was always less than 2.5 %, a value we set as reference rather 'expert judgment-like' and 5 % as boundary for H/G and 10 for G/M. Our boundary values are lower than the ones of the cyano-bloom metric from the UK, since they only take into account the summer period (July-September) when cyanobacteria mostly attain their maximal biomass. WISER project and the IC exercise actually proved the robustness of our simple metric.

Table A.3 Delineation of the various status classes for the metric species composition of phytoplankton in lakes based on the relative proportion of cyanobacteria expressed as relative biomass (%)

Class boundary	Relative proportion of cyanobacteria (%) – summer average	EQR
Reference	2,5	1
Boundary high/good	5	0.5
Boundary good/moderate	10	0.25
Boundary moderate/poor	25	0.1
Boundary poor/bad	50	0.05

The average relative proportion of cyanobacteria is adjusted for those lakes that are in high or good status for the chlorofyll a content and are characterised by the presence of picocyanobacteria and/of *Gomphosphaeria*-species. These taxa should not be taken into account.

The measures value for this metric is transformed into an EQR. This is obtained by dividing the reference (2,5 %) by the measured value. When the relative proportion of cyanobacteria is below this reference value, then the EQR is set equal to 1.

Total index calculation

The obtained EQR for the species composition is rescaled to a new scale (EQR_T), of which the class boundaries correspond to those for the metric biomass (calculated from the values in Table A.2). This rescaling is done by linearly transforming the obtained EQR value between the original class boundaries, expressed as EQR, to the new class limits, expressed as EQR. This transformation is done using the following formula:

$$EQR_T = OG_T + (BG_T - OG_T) * (EQR_{NT} - OG_{NT}) / (BG_{NT} - OG_{NT})$$

Met: BG: upper boundary of the relevant status class

OG: lower boundary of the relevant status class

T: transformed (linear)

NT: non-transformed (original)

As lower boundary for the class "bad" (not mentioned in Table A.2 and Table A.3), an EQR of 0 is used.

An original EQR for the metric species composition for the type Awe of 0.4, for example, will be transformed as follows:

$$EQR_T = 3.2/10 + (3.2/5.8 - 3.2/10) * (0.4 - 0.25) / (0.5 - 0.25) = 0.46$$

In the original system described by Van Wichelen et al. (2005), the final score is determined by taking the average of both EQR_T's, except when the difference between both metrics is more than 2 classes, in which case, the worst score is decisive. Lock et al. (2007) changed this by introducing the 'one out, all out' principle to this index. Hence the final score is always equal to the worst score of both metrics.

A.2 Denmark: Danish Lake Phytoplankton Index (DLPI)

Pressure addressed

Eutrophication. Data on DLPI relationship to total phosphorus concentrations has been demonstrated in the CB-intercalibration report (WFD Intercalibration Phase 2: Milestone 6 report on phytoplankton, by Geoff Phillips, December 2011). See also Søndergaard et al. (2011), showing for example the impact of nutrients on the dominance on cyanobacteria in Danish lakes.

Reference conditions

Due to absence of Danish reference lakes, reference conditions in Danish lakes are set by expert judgment, which has been modified during the intercalibration process. Danish lake phytoplankton flora under nutrient poor conditions, which will be close to reference conditions are for LCB1 and LCB2 lakes dominated by the species presented in Table A.4. The chlorophyll a ($\mu\text{g/l}$), %cyanobacteria (of total phytoplankton biomass), % chrysophytes (of total phytoplankton biomass) and the score of indicator species under reference conditions are listed in Table A.5 - first column.

Which indicators are used?

Two types of indicators are used: phytoplankton abundance and phytoplankton taxonomic composition. Both types are assessed based on summer mean values (1 May – 31 September).

Table A.4 Phytoplankton taxa indicative of nutrient poor or nutrient rich conditions (based on analyses of data from 691 lake-years). Nutrient poor taxa are defined as taxa where the median concentration of chlorophyll a in lakes in which they occur is below 30 $\mu\text{g/l}$ and the median total phosphorus concentration is below 50 $\mu\text{g P/l}$. Nutrient rich taxa are defined as taxa where at least 75% of the observations are from lakes with median chlorophyll a concentrations above 30 $\mu\text{g/l}$ and where at least 75% of the observations are from lakes with TP above 100 $\mu\text{g P/l}$. Only taxa which have been/taxa recorded at least/minimum 100 times (dates and lakes) are included in the list.

Algal class	Nutrient poor conditions	Nutrient rich conditions
Cyanophytes	<i>Gomphosphaeria lacustris</i> <i>G. littoralis</i> <i>Synechococcus elongatus</i>	<i>Woronichinia</i> sp. <i>Merismopedia tenuissima</i> <i>M. warmingiana</i> <i>Microcystis incerta</i> <i>M. viridis</i> <i>Cyanonephron styloides</i> <i>Anabaenopsis</i> sp. <i>A. elenkinii</i> <i>Lyngbya contorta</i> <i>Oscillatoria limnetica</i> v. <i>acicularis</i> <i>O. plantonica</i>

Algal class	Nutrient poor conditions	Nutrient rich conditions
Cryptophytes	<i>Radiocystis geminata</i>	
Crysophytes	<i>Dinobryon divergens</i> <i>D. bavaricum</i> <i>D. cylindricum</i> <i>D. sociale</i>	
Dinophytes	<i>Gymnodinium</i> sp. <i>G. uberrimum</i> <i>Peridinium cinctum</i> <i>P. inconspicuum</i> <i>P. volzii</i> <i>P. willei</i> <i>P. umbonatum</i> group <i>Mallomonas akrokomos</i> <i>Ochromonas</i> sp. <i>Uroglena</i> sp. <i>Chromulina</i> sp. <i>Apedinella/Pseudopedinella</i> sp	
Diatoms	<i>Synedra acus</i> v. <i>angustissima</i>	<i>Synedra berolinensis</i>
Euglenophytes		<i>Phacus</i> sp.
Chlorophytes	<i>Pseudosphaerocystis lacustris</i> <i>Ankyra lanceolata</i> <i>Botryococcus</i> sp. <i>Botryococcus braunii</i> <i>Eutetramorus fottii</i> <i>Spaerocystis schroeterii</i> <i>Stichococcus</i> sp. <i>Mougeotia</i> sp. <i>Oodogonium</i> sp.	<i>Actinastrum hantzchii</i> <i>Coelastrum astroideum</i> <i>Crucigenia tetrapedia</i> <i>Monoraphidium</i> sp. <i>Pediastrum</i> sp. <i>Scenedesmus</i> spp, <i>desmodesmus</i> group <i>S. spp, acutodesmus</i> group <i>S. acuminatus</i> <i>S. acuminatus/acutus</i> <i>S. opoliensis</i> <i>S. quadriquadra</i> <i>S. dimorphus</i> <i>Tetrastrum staurogeniaeforme</i> <i>Planktonema lauterbornii</i> <i>Closterium limneticum</i>

Phytoplankton abundance

Phytoplankton abundance indicators comprise three metrics: chlorophyll a concentration, percentage cyanobacteria (relative to total phytoplankton biomass) and percentage chrysophytes (relative to total phytoplankton biomass).

Phytoplankton taxonomic composition

The taxonomic composition of phytoplankton is assessed using the total species list based on all summer samplings. Phytoplankton is generally identified to species level, although this may not be possible for some genera. The total species list is divided into 30 taxa indicating nutrient poor conditions and 28 taxa indicating nutrient rich conditions. Species indicating nutrient poor and nutrient rich conditions are defined relative to their distribution along a total phosphorus and chlorophyll a concentration gradient. A taxonomic phytoplankton score is calculated as the number of taxa indicating nutrient poor conditions minus the number of taxa indicative of nutrient rich conditions.

Summary

The EQR is derived from four complementary indicators based on an abundance score and a taxonomic score:

- chlorophyll a concentration
- %cyanobacteria
- %chrysophytes
- number of species indicating nutrient poor conditions minus the number of species indicating nutrient rich conditions.

How are these indicators monitored?

Strategy

The entire waterbody is considered, based on one sampling from a central location. In shallow, non-stratified lakes a composite sample representing the photic zone is taken from the surface water. In deep stratified lakes a composite sample of the upper photic zone is taken; however, if the photic zone reaches into the hypolimnion a separate hypolimnion sample is taken. So far, the Danish assessment is based only on surface samples. The number of samples depends on the sampling programme, but ranges from 1 to 2 samples per month during summer.

The phytoplankton sample is fixed with Lugol's solution in glass bottles and stored in darkness until counting. Counting is done using an inverted microscope. At least 50 individuals of each of the dominant species/genera are counted. Size and dimensions used to calculate the biovolume are measured for 10-20 individuals of the species/genera which are estimated to comprise at least 90% of the total phytoplankton biovolume.

Assessment

Data requirements

For each lake data are needed on:

1. Lake mean depth
2. Total alkalinity
3. Chlorophyll a concentration for each sampling date.
4. Total phytoplankton taxa list.
5. Total biovolume of phytoplankton for each sampling date.

-
6. Total biovolume of cyanobacteria for each sampling date.
 7. Total biovolume of Chrysophyceae for each sampling date.

Method of calculation

For each lake a phytoplankton score is calculated based on Table A.5 below, divided into different lake types. The total phytoplankton score to be obtained ranges between 0 and 12. A maximum of three points can be obtained from each of the four indicators, yielding a maximum possible score of 12. The total score is translated into ecological class and phytoplankton-EQR based on Table A.6. Phytoplankton species indicating nutrient poor or nutrient rich conditions are listed in Table A.4.

Setting boundaries

In the absence of any Danish reference lakes boundaries settings are overall based on an expert judgment, which has been modified during the intercalibration process. Some of the original boundaries are however partly scientific based also. For example that cyanobacteria becomes more dominating in deep lakes with a high impact from external nutrient sources and that chrysophytes only comprises a significant part of the total phytoplankton biomass in lakes with a low external nutrient loading. The chlorophyll a boundaries used as one of the four metrics are the chlorophyll standards used in phase 1 of the intercalibration.

References

Søndergaard, M., Larsen, S.E., Jørgensen, T.B. & Jeppesen, E. 2011: Using chlorophyll a and cyanobacteria in the ecological classification of lakes. *Ecological Indicators* 11: 1403–1412.

Intercalibration of biological elements for lake water bodies

*Table A.5 Calculation of phytoplankton score (mean summer values). *Sum of taxa from nutrient poor lakes minus sum of taxa from nutrient rich lakes.*

Lake type/indicator	3 Points			2 Points			1 Point		
	TA<1 Z < 3	TA>1 Z < 3	TA>1 Z > 3	TA<1 Z < 3	TA>1 Z < 3	TA>1 Z > 3	TA<1 Z < 3	TA>1 Z < 3	TA>1 Z > 3
Alkalinity (meq/l)									
Mean depth (m)									
EU-lake type		LCB2	LCB1		LCB2	LCB1		LCB2	LCB1
Chlorophyll a (µg/l)	< 6.5	< 11.7	<6.5	[6.5,12]	[11.7,25]	[6.5,12]]12,27]]25,56]]12,27]
%cyanobacteria (of total biomass)	< 2	< 5	< 10	[2,5]	[5,10]	[10,20]]5,10]]10,20]]20,30]
% chrysophytes (of total biomass)	> 5	> 1	> 10	[1-5]	[0,5-1]	[5,10]	[0,1[[0,0.5[[0.5,5[
Indicator species*	>4	> 4	> 4	[2-4]	[2-4]	[2-4]	[-1,1]	[-1,1]	[-1,1]

Table A.6 Calculation of phytoplankton-EQR and ecological class based on total score (0-12 points).

Total score	Phytoplankton-EQR	Phytoplankton EQR and ecological class
0	0.1	Bad (0-0.2)
1	0.23	Poor (0.2-0.4)
2	0.30	Poor (0.2-0.4)
3	0.37	Poor (0.2-0.4)
4	0.43	Moderate (0.4-0.6)
5	0.50	Moderate (0.4-0.6)
6	0.57	Moderate (0.4-0.6)
7	0.63	Good (0.6-0.8)
8	0.70	Good (0.6-0.8)
9	0.77	Good (0.6-0.8)
10	0.83	High (0.8-1)
11	0.90	High (0.8-1)
12	0.97	High (0.8-1)

A.3 Estonia (EE)

Sampling

In the Estonian lakes the phytoplankton is surveyed each year. The frequency of sampling has increased since 2006, from two times a year to four times a year (Table A.7). The abundance of phytoplankton is expressed in terms of biovolume.

Table A.7 The Estonian approach of phytoplankton monitoring.

Item	Old program	Program since 2006, since 2007 surveillance monitoring
Long term frequency	Each year	Each year
Frequency per year	May, July	May, July, August, September
Sampling	Depending on stratification 2-3 samples (epilimnion 0.5 m, mid metalimnion, hypolimnion) from the deepest point. If lake has curved shoreline, then from different parts from the lake	Depending on stratification 2-3 samples (epilimnion 0.5 m, mid metalimnion, hypolimnion) from the deepest point. If lake has curved shoreline, then from different parts from the lake
Sampling methods	Van Dorn sampler (for counting) and Apstein net (for adjustment of species list)	Van Dorn sampler (for counting) and Apstein net (for adjustment of species list)
Level of identification	Species level if possible, but also large taxa are used (class, order) as indicators	Species level if possible, but also large taxa are used (class, family) as indicators
Calculation of biomass	Utermöhl's technique, Nordic guidance of calculations	Utermöhl's technique, Nordic guidance of calculations

Assessment

The Estonian method is a multimetric method that uses four parameters to assess the ecological quality of the phytoplankton:

1. **Chlorophyll a.**
2. **Evenness - modified Pielou index** is used. The range of values is between 0 - 1. The scale is divided equally into five classes in each lake type. The basis of that index is the idea that the abundance of species is equally distributed in climax communities. A climax community has a high ecological quality. In fact equation is calculated from Shannon's diversity (H). Another component of the equation is theoretical diversity (Hmax). The latter is calculated if considered that the abundance (or biomass) is equally divided with concrete number of species in sample. Equation: $J = H/H_{max}$. The higher value, the better ecological quality.
3. **Nygaard's modified compound quotient (PCQ).** The modified Nygaard's (1949) phytoplankton compound quotient is used to characterize the ecological status of the lake. PCQ gives a quite good estimation of the lakes' ecological

condition, although algal groups in formula may contain species with different preferences. Ott & Laugaste (1996) added to the original formula two extra taxa: Cryptophyta to the numerator and Chrysophyceae to the denominator. This modified index gives a more precise assessment of the Estonian lakes, because the abundance of Desmidiaceae, the only taxon originally used in the denominator, has dramatically declined during the past decades both in open water as in the littoral zone (Kangro et al. 2005).

P CQ, modified by Ott & Laugaste (1996):

$$PCQ = \frac{\text{Cyanophyta} + \text{Chlorococcales} + \text{Centrales} + \text{Euglenophyceae} + \text{Cryptophyta} + 1}{\text{Desmidiaceae} + \text{Chrysophyceae} + 1}$$

4. **Description of the community:**

There are four possible categories:

Abundance of species is more or less equal and it is impossible to determine dominants

3-5 species dominate in abundance (>80%)

1 species dominates in abundance (>80%)

Prevailing genera by abundance are Microcystis, Apahnizomenon, Radiocystis, Planktothrix, Limnothrix, Woronichinia, Anabaena or alga from order chlorococcales. The content of Chla is > 20 mg/m³. (Since we did not have data on abundance we use biomass instead.)

The final score is summarized using principle of equal weight of used parameters. Each quality class has own score (h -1; g- 2 etc.). Arithmetical avg gives hint to final score which is achieved by rounding off. The national EQR values are therefore discontinuous and are defined as H/G=0.8, G/M=0.6, M/P=0.4, P/B=0.2.

Reference and boundary setting

In Estonia the "true reference sites" (chosen according to the Lake CB GIG common reference criteria) occur for the L-CB1 and L-CB3 type of lakes. At the moment Estonia does not have a "true reference site" for the L-CB2 type of lakes. In 2007 three potential reference lakes of L-CB2 were surveyed.

Reference values for all lake types are inferred from the following information:

- Measured values of reference sites. Criteria for reference sites are described in CBGIG reports;
- Historical data (most of the older data goes back to the 1950s, few data to the 1920s);
- paleolimnological investigations (Alliksaar, T. et al. 2005; Nõges, T. et al. 2006; Heinsalu, A. et al.);
- Expert judgment;

-
- Other principles described in the Water Framework Directive Annex II, 1.3).

Reference values of the phytoplankton biomass and composition parameters were derived as followed:

Chlorophyll-a (Chl-a, µg/L, calculated as average content of chl-a values measured in different limnological layers, all samples of the lake year)

In cases when the “true reference sites” - the lakes that fulfill the Lake Central Baltic GIG common reference criteria (no point pollution sources at the catchment, inhabitants up to 5 pers/km² catchment, artificial land use up to 10 % in catchment) exist, the reference indicator values are measured at the reference site. In case when there were no true reference sites left, the reference conditions were delivered by using statistical relations between chl-a and Secchi transparency.

Pielou evenness J_i: Values range between 0-1. 1 is theoretical maximum and therefore also the reference value in all types (L-CB1, L-CB2, L-CB3). For PPS scoring average value of the phytoplankton samples from different limnological layers, all samples of the lake year were used.

Compound quotient: 2/3 of Estonian natural lakes with area >1 ha are investigated and 2/3 of them have historical data, mainly since 1950s. These provide knowledge about the historical background. Reference values of the phytoplankton compound quotient are different in lake types (L-CB1- 2.5; L-CB2 - 2). Frequency diagrams of reference sites are also used to set reference values. For PPS scoring average value of the phytoplankton samples from different limnological layers, all samples of the lake year were used.

Description of community: The parameter was elaborated during the ECOFRAME project in which Estonia participated (Moss *et al.* 2003). Description of the reference community matches to the description in WFD. This parameter does not give any numerical value.

The four possible categories (see above) are evaluated as follows:

- Category 1 corresponds to High and Good classes;
- Category 2 to Moderate class;
- Category 3 to Poor class;
- Category 4 to Bad in all lake types.

For PPS scoring average value of the phytoplankton samples from different limnological layers, all samples of the lake year were used.

The lake phytoplankton method (combination of four parameters mentioned above) boundary setting is based on the following information:

1. Estonia's lake classification systems used before 2000 (Milius & Kõvask, 1982, 1983, 1989, Mäemets, 1977; Milius et al., 1992; Ott & Laugaste, 1996; Milius & Starast, 1996; Ott & Kõiv, 1999);

-
2. Results of the ECOFRAME project (Ecological quality and functioning of shallow lake ecosystems with respect to the needs of the European WFD), where most member states were participating, Estonia participated as associated state (Moss et al., 2003).

At the calculation of the final lake phytoplankton score (PPS) (in Estonian FPK - füttoplanktoni koondhinnang) principle of equal weight of parameters is used. Each phytoplankton parameter value is scored according to the quality class:

- High – 1;
- Good – 2;
- Moderate – 3;
- Poor – 4;
- Bad – 5.

Arithmetical average of each parameter value scores gives hint to final lake phytoplankton score (PPS) which is achieved by rounding off. Final score:

- High: 1.00 - 1.50;
- Good: 1.51 - 2.50;
- Moderate: 2.51 - 3.50;
- Poor: 3.51 - 4.50;
- Bad: 4.51 – 5.00.

The national EQR values are therefore discontinuous and are defined as H/G=0.8; G/M=0.6; M/P=0.4; P/B=0.2.

Regarding that the phosphorus content (the widely used pressure indicator) in most EU member state's lakes is considerably higher than the phosphorus content in Estonian lakes (the total P median value in Estonia is 0.038 mg/L), and the pressure intensity is low (total P pressure range is narrow) in Estonian lakes, Estonia decided to use the lake catchment total pressure index (LCI) in order to show the sensitivity of the Estonian lake phytoplankton method.

The lake catchment area total pressure index (LCI) = estimated pressure from households+ estimated pressure from land use+ estimated pressure from cattle breeding+ estimated pressure from secondary pollution, where:

- Estimated pressure from households at the subjective scale between 0-4 (expressed as number of inhabitants/km² catchment area/lake water volume m³);
- Estimated pressure from land use at the subjective scale between 0 – 4 (expressed as percentage of natural and agricultural land use is calculated by equation: (100 - % of natural land use) + % of agricultural land use);
- Estimated pressure from cattle breeding at the subjective scale between 0 – 4 (expressed as number of domestic animals - cattle, sheep, domestic fowl, pigs, goats- in animal units /km² atachment/lake water volume m³);

-
- Estimated pressure from secondary pollution (contaminated sediments and water table lowering) is based on recorded old information and is subjective estimation with 3 values: 0, 2 and 4 (0 - no secondary pollution, 2- moderate secondary pollution, 4 - strong secondary pollution).

Estonian lake phytoplankton method details and its class boundary setting procedure are presented during the intercalibration phase I and phase II to the Baltic Central Lake Geographical Intercalibration Group, and the class borders are harmonized with other member states during the Intercalibration phase II (see the Intercalibration phase I and II final reports).

In addition to the LCI some other ecological status indexes were used in class boundary setting and the method sensitivity analysis.

1. The Estonian lake trophic status index (Ott et al., 2005);
2. Carlson Trophic Status Index (Carlson, 1977) and the Estonian modification of that index (Milius, 1993).

Figure A.1 illustrates the final lake phytoplankton score (PPS) class boundary setting according to the correlation with lake catchment area total pressure index (LCI). For the analysis referred at Figure A.1 the state lake monitoring data of 2007-2010 were used. Only LCB1 and LCB 2 lake data are referred at the Figure A.1. The variability of the lake surface area is very high.

Untypical value is lake Konsu, where LCI value 12 responses to the PPS high EQR value. The groundwater, pumped out from the oil shale minings, is directed through lake Konsu and probably has the stronger effect to the PPS than LCI.

Untypical is also the lake Saadjärv (LCI value 8, responses to PPS high EQR in some samples). Big water volume in that lake has remarkable effect to the response of the phytoplankton community to the catchment area pollution load.

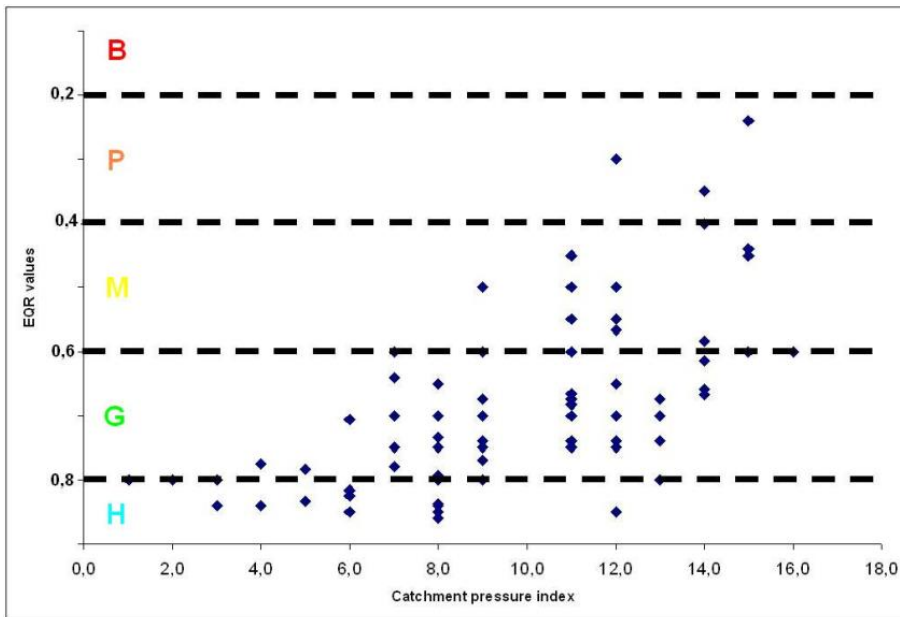

Figure A.1 Estonian Final Lake Phytoplankton Score (PPS) EQR correlation with lake catchment area pressure index (LCI).

Figure A.2 illustrates correlation between Final Lake Phytoplankton Score (PPS) and Estonian trophic state index (Ott et al., 2005). Dashed red line indicates standard deviation. Since index mentioned above uses some specific parameters, the number of cases is relatively low.

Figure A.3, Figure A.4 and Figure A.5 illustrate correlation between Final Lake Phytoplankton Score (PPS) and Carlson's Trophic State Index. The Carlson's TSI can be calculated with three parameters (total phosphorus concentration, Secchi disc transparency and/or content of chl a) and the extent of values is between 1 and 100. Majority of the PPS values show significant correlation to all trophic state indexes.

In Figure A.5 the correlation between modified PPS (phytoplankton score without chl a) and Carlson TSI (chl a) is shown. All expressed correlations on Figure A.3, Figure A.4 and Figure A.5 are statistically confident.

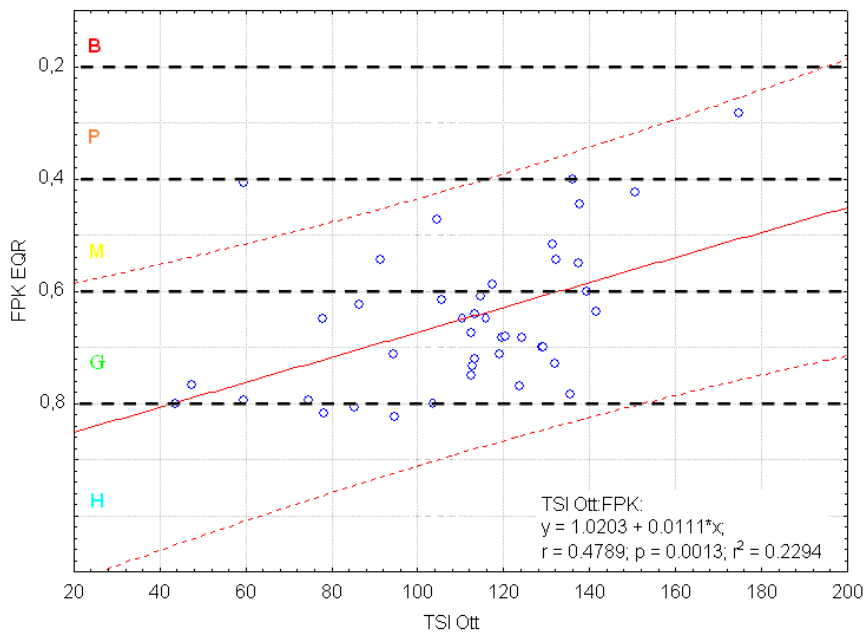

Figure A.2 Estonian Final Lake Phytoplankton Score (PPS) EQR (FPKEQR) correlation with Estonian trophic state index (TSI Ott).

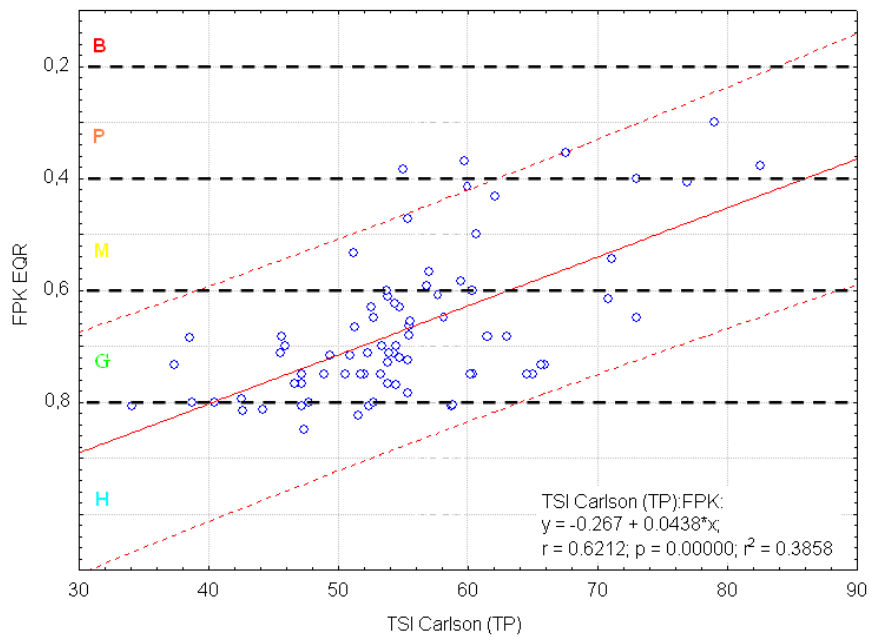

Figure A.3 Estonian Final Lake Phytoplankton Score (PPS) EQR (FPKEQR) correlation with Carlson's Trophic State Index calculated on total phosphorus content (TSI Carlson TP).

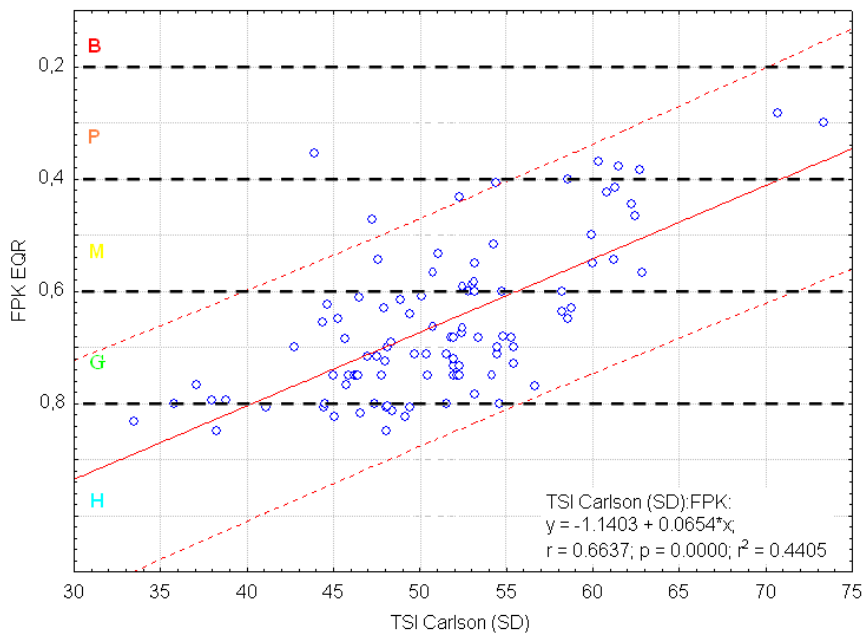

Figure A.4 Estonian Final Lake Phytoplankton Score (PPS) EQR (FPKEQR) correlation with Carlson's Trophic State Index calculated on Secchi disc visibility (TSI Carlson SD).

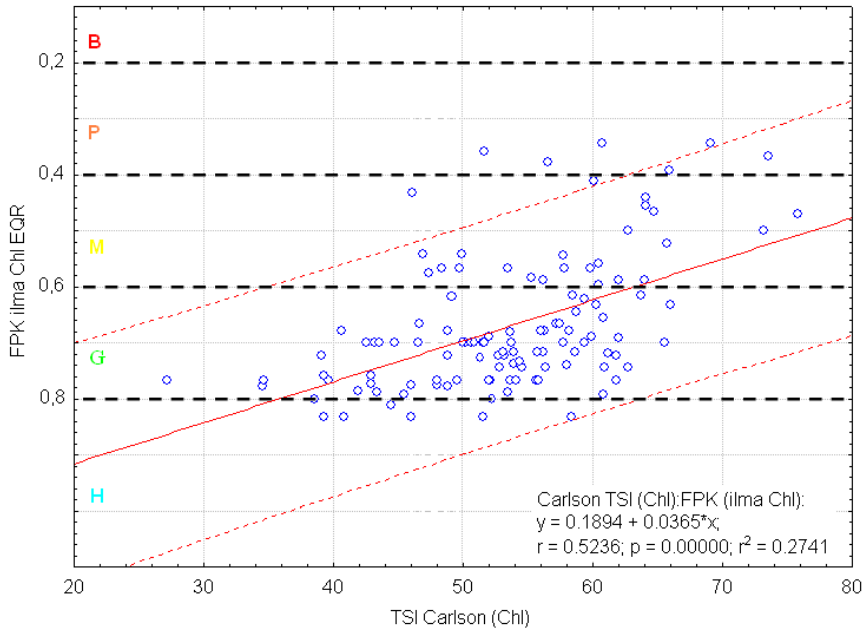

Figure A.5. Modified Estonian Final Lake Phytoplankton Score (mPPS) EQR (FPK ilma Chl EQR), where chl a score is not included) correlation with Carlson's Trophic State Index calculated on chl a concentration (TSI Carlson Chl). Füttoplanktoni koondhinnang ilma klorofüllita (FPK ilma Chl) = Modified Final Lake Phytoplankton Score (mPPS) = PPS where chl a score is not included

The final assessment

The LCB1 and LCB2 lake types phytoplankton is estimated using 5 indicators (chl-a total column, Chl-a surface, Description of community, Compound quotient, Pielou evenness). PPS is calculated as average score of all indicators. Every indicator gets status score, total phytoplankton score (PPS) is arithmetic average of the single indicator scores (see table below).

References

Ott, I. ja T. Kõiv, 1999. Eesti väikejärvede eripära ja muutused. Special features and changes in Estonian small lakes Tallinn, 128 lk. (pp.).

Aquatic conservation: Marine and Freshwater Ecosystems, vol 16, issue 6, pp 507-549, Nov/Dec 2003

Kõvask, V. & Milius, A., 1982. Lõuna-Eesti järvede fütoplankton. - Eesti NSV järvede nüüdisseisund. Tartu, 75-85.

Kõvask, V. & Milius, A., 1983. Priznaki evtrofirovaniya nekotoryh oligotrofnyh ozer Estonii. - Metsanduslikud uurimused. XVIII. Looduse kaitse. Tallinn, 55-66.

Kõvask, V. & Milius, A., 1989. Biogeensed elemendid ja fütoplankton Rõuge järvedes. - Eesti LUS aastaraamat. 71: 148-157.

Mäemets, A., 1977. Eesti NSV järved ja nende kaitse. Tallinn, "Valgus", 263 lk.

Milius, A., 1993: Relationship between water transparency and chlorophyll a concentration. - Proc. Sci. Estonian Acad. Sci. Biology. 42, 68-77.

Milius, A., Saan, T., Lindpere, A., Starast, H. 1992: Yearly changes in totalphosphorus and chlorophyll a concentrations in Estonian lakes. Proc. Estonian Acad. Sci. Ecol., 2, 3, 103-109.

Milius, A., Starast, H., 1996: Response of chlorophyll a concentration to totalphosphorus decrease in SE Estonian small lakes. Proc. Estonian Acad. Sci., Ecol., 6, ½, 79-88.

Moss et al., 2003. The determination of ecological status of shallow lakes- a tested system (ECOFAME) for implementation of the European Water Framework Directive. Aquatic Conservation, 13, 507 - 549.

Nygaard, G. 1949. Hydrobiological studies on some Danish ponds and lakes II. The quotient hypothesis on some new or little known phytoplankton organisms. Det Kongelige Danske Videnskabernes Selskab 7: 293 pp.

Ott, I., Kõiv, T., Nõges, P., Kisand, A., Järvalt, A. & E. Kirt. 2005. General description of partly meromictic hypertrophic Lake Verevi, its ecological status, changes during the past eight decades and restoration problems. Hydrobiologia 547:1-20.

Ott, I., Laugaste, R., 1996. Fütoplanktoni koondindeks (FKI). Üldistus Eesti väikejärvede kohta. - Eesti Keskkonnaministeeriumi Infoleht nr. 3

A.4 France (FR)

Sampling and analyses

The French assessment method requires a fixed standardized method for sampling, conservation and storage, and microscopic analysis. This is described in the "Standard protocol...version 3.3.1", Laplace-Treytore & al., 2009.

For the assessment, four samples per year are needed from euphotic zone at the deepest point of the lake. Three of these samples must be taken in the period May to October.

The phytoplankton analysis follows the recommendation of the guiding standard (NF EN 15204, 2006) corresponding to the Utermöhl technique. All the taxonomic identifications are made down to species level when possible but to genus or class in the event of difficulties or uncertainty. The results are provided in biovolume (mm³/l) for each taxa determined.

Assessment

The French assessment method is a multi-metric index called IPLAC for "indice planctonique lacustre" which is the result of a weighted average of the two following metrics:

- MBA or total Algal Biomass Metric. This metric is based on the rate of chlorophyll-a during the growing season.
- MCS or Specific Composition Metric This metric expresses a score based on the presence of indicator taxa included in a list of 178 taxa which have a specific indicator taxa score and a stenocyc factor.

The two metrics are aggregated with the following formula:

$$IPLAC = \frac{MBA_{nEQR} + 2MCS_{nEQR}}{3}$$

With: MBA_{nEQR} = MBA expressed in normalized EQR,

MCS_{nEQR} = MCS expressed in normalized EQR.

The aggregation is done after normalization of metric MCS and MBA, so the calculated index does not need to be normalized. The quality thresholds of IPLAC are conventional standards thresholds.

IPLAC Thresholds	
H	<< 0.8
G	<< 0.6
M	<< 0.4
P	<< 0.2
B	

For detail on the calculation of IPLAC, see the document of the method description (Menay & Laplace-Treytore, 2011).

Reference and boundary setting

MBA metric

Reference Condition (RC) are site specific, based on a mathematical model between chlorophyll-a and mean depth.

$$refChloro = 10^{0.754 - 0.489 \cdot \log(meanDepth)}$$

Boundary value H/G is the Prediction Interval of 90th % of the model. Other boundaries are based on the pressure-impact model with log(TP), equal size classes (same distance as between ref and H/G limit), see Figure A.6.

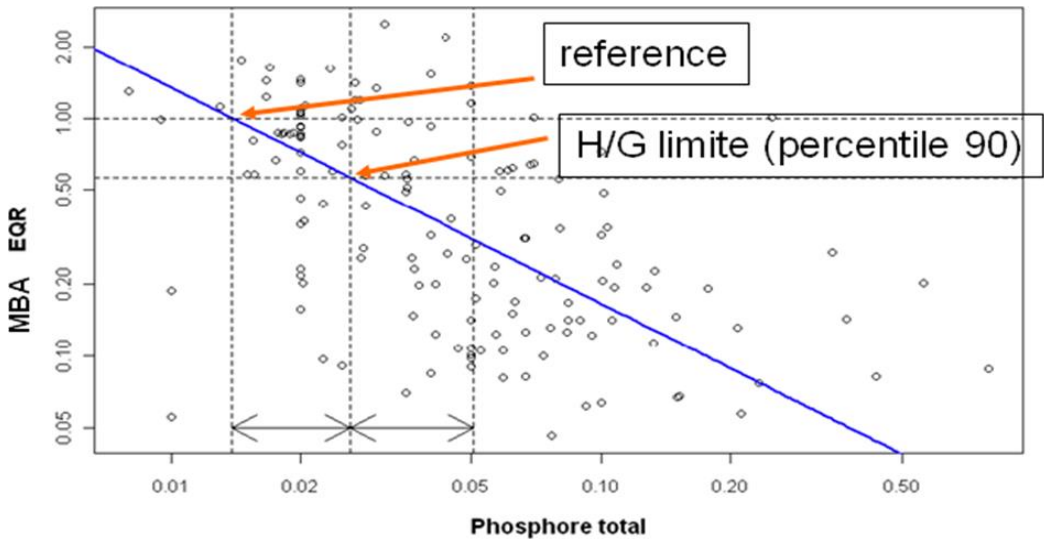

Figure A.6 Construction of the MBA boundaries with a pressure-impact model with log of total phosphorus

MCS metric

RC are specific per macro lake type (Table A.8), based on ref sites (median value of MCS on ref site per macro lake type) or site specific (when not enough ref sites in macro lake type), based on a mathematical model (regression with TP).

Table A.8 French macro lake types

		Altitude (meter)		
		0-200	200-800	>800
BA : Low altitude MA : Medium altitude HA : High altitude 1, 2, 3 : low, medium, and high depth				
Depth (meter)	0-3	BA 1	MA 1	HA 1
	3-15	BA 2	MA 2	HA 2
	>15	BA 3	MA 3	HA 3

Boundary value H/G is the 95th % of the distribution on ref sites or the prediction interval of 95th % of the model with log(TP) when not enough ref sites in the macro lake type. Other boundaries are based on the pressure-impact model with log (TP), equal size classes (same distance as between ref and H/G limit).

References

Laplace-treyture C, Barbe J., Dutartre A., Druart J-C., Rimet F., Anneville O., 2009. Standard protocol for sampling, conservation, observation and counting of lake phytoplankton for application of the WFD. Version 3.3.1. Cemagref UR REBX. Cestas, France. 42 p.

Menay M., Laplace-Treyture C., 2011. Ecological status assessment of French water bodies: the phytoplankton index of lakes – IPLAC. Method description. Version 1. 16 p.

NF EN 15204, 2006. Qualité de l'eau, Norme guide pour le dénombrement du phytoplancton par microscopie inversée (méthode Utermöhl), AFNOR. 39 p.

A.5 Germany (DE)

Sampling and analyses

The German assessment procedure includes and requires a fixing of standardized methods for sampling, preservation and storage, and microscopic analysis (Nixdorf et al. 2010).

For the assessment six samples per year are needed from epilimnion or euphotic zone (clear water lakes, of which four samples must be taken in the period May-September. The taxa are counted according the Utermöhl technique and coded by the operational phytoplankton taxa list. To determine indicator species additional diatom preparation is recommended.

Assessment

The German phytoplankton-based assessment system for lakes (Mischke et al. 2008) yields a multi-metric index value, the Phyto-See-Index (PSI), and differentiates between different lake types. It classifies water bodies into one of five status classes in accordance with the Water Framework Directive (WFD). The PSI consists of three mandatory metrics: "biomass", "algal classes" and the "Phytoplankton-Taxa-Seen-Index" (PTSI).

The three compulsory metrics along the stressor "eutrophication" are calibrated and adjusted in accordance with reference sites and trophic reference conditions. Total phosphorus and the actual assessment value of the German Trophic Index (LAWA 1999) served as the stressor scale. The German Trophic Index is based on the combined classification of the common trophic parameters "chlorophyll-a", "total phosphorus" and "secchi depth" as a measure of lake transparency..

The PSI is composed of three mandatory metrics and an optional fourth metric, DI-PROF, latter not included into intercalibration. Some of these metrics are multi-parameter variables.

1. Biomass metric: this is composed of
 - a. The total biovolume of phytoplankton in the epilimnic or euphotic zone of the lake (arithmetic mean in the vegetation period from April to October of six samples);
 - b. Chlorophyll-a concentration (arithmetic mean in the vegetation period from April to October);
 - c. Maximum Chlorophyll-a value, if it deviates from the mean more than 25%.
2. Algal class metric: the biovolume or its percentage of total biovolume in specific annual periods (e.g. mean values of cyanophytes, dinophytes and of chlorophytes from July to October; mean value from chrysophytes from April to October);
3. PTSI (Phytoplankton Taxa Lake Index): this index evaluates the species composition based on lake-type specific lists of indicator species (332 different species) and their special trophic scores and weighting factors. The method works in two steps:
 - a. trophic assignment results in a PTSI index per sample or lake year;
 - b. assessment by comparing current trophic state with the lake type specific trophic reference status

The results of all components and of the final index are an index value between 0.5 and 5.5 which can be easily transformed to a normalized EQR ($y = -0.2x + 1.1$) (Table A.9).

Table A.9 Transformation of the metric index value to normalized EQR.

German metric index value	Normalized EQR
0.5 – 1.5	0.8 – 1
1.51 – 2.5	0.6 – 0.8
2.51 – 3.5	0.4 – 0.6

3.51 – 4.5	0.2 – 0.4
4.51 – 5.5	0.0 – 0.2

The final score is summarized using weighting factors of used components before averaging the metric results (details in Mischke et al. 2008).

Reference and boundary setting

The class boundaries for the total biovolume and the metric algal classes are derived by using a pre-assignment of ecological quality of the lakes. The assignment was based on a trophic score, the German LAWA-index, the estimation of local experts and in consideration of the lake type specific trophic reference state. The trophic reference status of lake types are defined (in first draft) with a view to palaeolimnological investigations, true reference sites without anthropogenic impact and ideas about background concentrations of total phosphorus and morphometric conditions in lakes. Trophic reference status is given as a trophic class according to the German LAWA-approach for assessing lakes (LAWA 1999), which combines criteria for chlorophyll a, total phosphorous and transparency (SD). During the intercalibration exercise the German reference boundaries for chlorophyll a were adjusted to intercalibration results. The trophic scores of indicator species for the PTSI were developed along the trophic gradient, German LAWA index and total phosphorus concentrations.

References

LAWA (1999) Gewässerbewertung Stehende Gewässer. Vorläufige Richtlinie für eine Erstbewertung von natürlichen entstandenen Seen nach trophischen Kriterien. Kultur-Buch Verlag, Berlin. 74 p.

Download link for taxa list codes and for calculation tool PhytoSee: http://www.igb-berlin.de/staff_.html?per_page=0&search=lastname&for=mischke&show=117#ankerartikel0

Mischke, U., Riedmüller, U., Hoehn, E. Schönfelder, I. & Nixdorf, B. (2008): Description of the German system for phytoplankton-based assessment of lakes for implementation of the EU Water Framework Directive (WFD). Chapter IN: Mischke, U. & B. Nixdorf (editors), Gewässerreport 10, Aktuelle Reihe 2/2008 ISBN 978-3-940471-06-2: 117-146 p., University Cottbus. Link: <http://opus.kobv.de/btu/volltexte/2009/953/>

Nixdorf, B., Hoehn, E., Riedmüller, U., Mischke U. & I. Schönfelder (2010): III-4.3.1 Probenahme und Analyse des Phytoplanktons in Seen und Flüssen zur ökologischen Bewertung gemäß der EU-WRRL. In: Handbuch Angewandte Limnologie – 27. Erg.Lfg. 2/10 1.ISBN 3-527-32131-4, 1- 24 p.

A.6 Ireland (IRL)

Sampling and analyses

Chlorophyll *a*

Sub-surface samples are taken from mid-lake stations. Chlorophyll *a* is determined following extraction using spectrophotometric analysis. Sampling frequency ranges from a maximum of 12 times per year to a minimum of 4 times per year between January and December. Spatial replication depends on lake size with more stations on larger lakes.

Phytoplankton composition metric

The phytoplankton composition metric provides an indication of the state of community composition and abundance in relation to the eutrophication pressure gradient. Assessment is based on two summer (1st June to 7th of September) mid-lake sub-surface samples taken annually over a three year monitoring period. Phytoplankton are counted following the Utermöhl technique..

Assessment

In the Republic of Ireland, status for the biological quality element (BQE) phytoplankton is assessed using two parameters: chlorophyll *a* as a measure of phytoplankton biomass and a taxonomic composition metric. These parameters are normalised so that their boundaries and class widths are on the same scale and then averaged (Figure A.7) This document summarises methods and the process of boundary setting for the intercalibration types:

L-CB1: Lowland, shallow calcareous lakes less than 200 m in altitude, of mean depth between 3 and 15 m with an alkalinity > 1 meq l⁻¹ and with a residence time of 1 to 10 years.

L-CB2: Lowland, very shallow calcareous lakes less than 200 m in altitude, of mean depth < 3 m with an alkalinity > 1 meq l⁻¹ and with a residence time of 0.1 to 1 year.

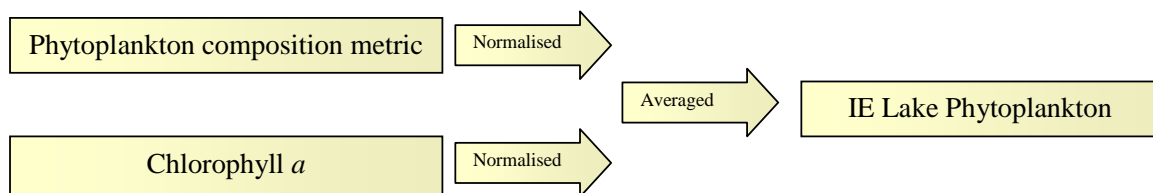

*Figure A.7 Phytoplankton composition and chlorophyll *a* parameters are normalised and averaged annually to provide an IE Lake Phytoplankton Index value.*

Reference values for L-CB1 were decided at GIG level and are detailed in the Water Framework Directive Intercalibration Technical Report - Part 2: Lakes (Poikane, 2008) and in the Intercalibration decision (EC, 2008). Although Ireland was not a member of the Central Baltic GIG in the first round of intercalibration the L-CB1 type is the same abiotic type as the Atlantic GIG type LA1/2 intercalibrated by Ireland and the UK in the first round and the boundaries are the same (EC, 2008).

Chlorophyll metric

The national approach to setting chlorophyll a boundaries for lakes within the L-CB1/LA1/2 type (alkalinity > 1 meq l⁻¹, mean depth 3-15 m) was previously outlined on pages 32 to 40 of section 2 of the Annex to Poikane (2008). For L-CB2, the boundaries agreed in the 1st round of intercalibration in the CBGIG were not used. This was because the good moderate boundary previously agreed (23 µg l⁻¹ Chl a) was very high in an Irish context, being double all other types intercalibrated (Figure 3.1b, p73, Poikane, 2008). Instead the boundary setting procedure for the LA1/2 lakes was used to establish boundaries for L-CB2. Following the application of reference values and boundaries, the chlorophyll a EQR is normalised per lake type using Equation 1 below where the max EQR is set to 2.14.¹

Equation 1:

$$\frac{(EQR - \text{lower EQR boundary}) * (\text{normalised upper boundary} - \text{normalised lower boundary})}{(\text{upper EQR boundary} - \text{lower EQR boundary})} + \text{normalised lower boundary}$$

Table A.10 The boundaries of IE status classes for chlorophyll a µg l⁻¹ for L-CB1 and 2

	Chl a	EQR	Chl a	EQR
Boundary				
Type	L-CB1	L-CB1	L-CB2	L-CB2
Reference Chlorophyll a	3.20		3.50	
High/Good	5.82	0.55	6.36	0.55
Good/Moderate	10.00	0.32	10.94	0.32
Moderate/Poor	20.00	0.16	21.88	0.16
Poor/Bad	40.00	0.08	43.75	0.08

Phytoplankton composition metric

The phytoplankton composition metric provides an indication of the state of community composition and abundance in relation to the eutrophication pressure gradient. Assessment is based on two summer (1st June to 7th of September) mid-lake sub-surface samples taken annually over a three year monitoring period. Phytoplankton are counted following the Utermöl technique. Assessment is based on nine groups or genera of indicator taxa, each of which is awarded a score ranging from 1 to 0.1 based on abundance. Sample chlorophyll a is also awarded a score ranging from 1 to 0.1. The scores are averaged to produce a phytoplankton composition metric value. See Table 4.10 in Free et al. (2006) for scores and further information.

¹ Where chl a is lower than the reference value this results in an EQR >1. This can distort the dataset when chlorophyll a is very low. To deal with this we set the upper EQR of the high class to the 10th percentile of the parameter value (towards high status). For chlorophyll a the lower 10% of the GIG data classified as high status was 1.6375. So 3.5 (ref)/ 1.6375 = 2.14 we used this as max EQR and this should improve the distribution generally but there is a need to truncate occasional EQR values >1.

In order to establish a reference value for the composition metric an average metric value of 15 lake 'years' (10 lakes in total) was taken from a set of lakes in reference status. The reference lakes selected were those confirmed as being in reference condition by a palaeolimnological study of 34 candidate reference lakes (Taylor et al., 2006). These lakes had similar assemblages from a comparison of top and bottom core samples (a squared chord distance of 0.40 was used). The lakes chosen were Loughs Barfinnihy, Bunny, Doo, Dunglow, Keel, Kiltorris, Nahasleam, O'Flynn, Upper Lough Veagh and Upper. Lough McNeen, although confirmed to be in reference status, was excluded owing to its high TP concentration ($24 \mu\text{g l}^{-1}$). The average reference composition metric value for these lakes was 0.9383. This was used as a denominator to generate an EQR following guidance document 10 (Tool 3 page 53, REFCOND (2003)).

Figure A.8, taken from Free *et al.* (2006), shows the response of three phytoplankton taxa to TP in lakes of alkalinity between 0.4 and 2 meq l^{-1} . Generally at TP values less than $10 \mu\text{g l}^{-1}$ there is an absence or low abundance of eutrophic taxa such as *Pediastrum* or *Scenedesmus*. Whereas between 10 and $25 \mu\text{g l}^{-1}$ TP some slight changes occur such as an increase in the presence and abundance of *Scenedesmus*. At concentrations greater than $25 \mu\text{g l}^{-1}$ *Pediastrum* occurs more frequently in higher abundance and, in line with normative definitions for moderate status, the biomass increases (chlorophyll *a* indicated by green smoothed line). This can be related to a 'significant undesirable disturbance in the condition of other biological quality elements' (Annex 5, WFD). This is visible in the accompanying graphs for macrophytes that show after $25 \mu\text{g l}^{-1}$ TP there is a significant loss of charophytes and also that there is an increased absence of isoetid taxa (including the widely distributed *Littorella*) (Figure A.8). This $25 \mu\text{g l}^{-1}$ concentration could therefore be used to indicate where a boundary for good/moderate status in the phytoplankton composition metric lies. Poor status may be difficult to decide but could be around $70 \mu\text{g l}^{-1}$ TP where there is a complete absence of charophytes.

Table A.11 The boundaries of IE status classes for the phytoplankton composition metric. National boundaries and intercalibration boundaries (using biovolume data) for both L-CB1 and 2.

Boundary	Composition metric value ²	EQR ³	Composition metric value ²	EQR ²
Type	L-CB1&2	L-CB1&2	L-CB1&2	L-CB1&2
Reference	0.9383		0.8421	
High/Good	0.9160	0.9760	0.8240	0.9785
Good/Moderate	0.7540	0.8040	0.6923	0.8221
Moderate/Poor	0.4050	0.4320	0.4087	0.4853
Poor/Bad	0.2476	0.2640	0.2808	0.3330

² Original national values for phytoplankton composition metric.

³ Modified values for use in intercalibration for biovolume data.

A nonparametric multiplicative regression (NPMR) model was used to model the response and predict the phytoplankton composition metric values for given TP concentrations. The models xR^2 was 0.69 and was significant ($p < 0.001$). This model was then used to predict the phytoplankton composition metric values for a given range of TP concentrations of relevance for boundary setting (Table A.11). It is important to realise that the TP boundaries are not being used directly to assess boundary status classes, rather it is the TP concentrations from points of ecological change (Figure A.8) that are being used to estimate the metric values by NPMR. This will serve to inform the national position until such boundaries are formally intercalibrated through the EU intercalibration exercise. The phytoplankton composition metric EQR is then normalised per type using Equation 1 above.

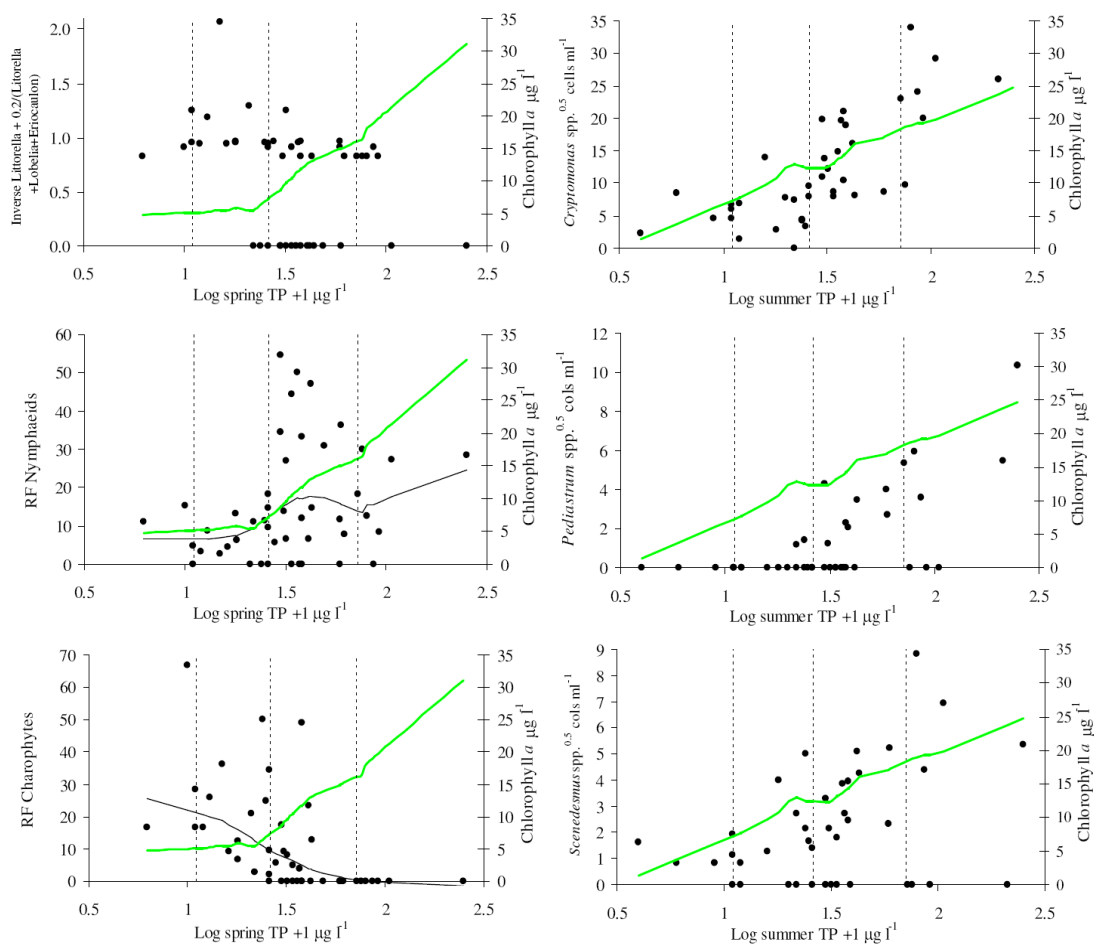

Figure A.8 Relationship between TP (Spring or Summer) and selected macrophyte metrics (left) and phytoplankton taxa (right) for lakes between 0.4 and 2 meq l⁻¹ alkalinity. The lowest smoothed relationship between TP and summer chlorophyll a is overlain (—). Dashed lines represent concentrations of 10, 25 and 70 µg l⁻¹ TP.

Bloom metric

A separate metric was not developed for phytoplankton blooms. This was because the existing IE lake phytoplankton index is already correlated with the biovolume of cyanophytes and including an additional metric based on cyanophytes did not increase the ability to detect responses to pressure.

Combination Rules

Two parameters are combined to provide an assessment of the BQE: chlorophyll *a* as a measure of phytoplankton biomass and the phytoplankton composition metric. These parameters are normalised using Equation 1 above so that their boundaries and class widths are on the same scale and then averaged to give an annual value of the IE lake phytoplankton index. A mean value and confidence is then calculated from three years of data.

Method performance

The r^2 between the composition metric and log transformed TP was 0.67 for 129 Irish lakes (Free *et al.*, 2006). The r^2 between log transformed chlorophyll *a* and TP was 0.58 for 31 Irish lakes (Irvine, 2001). The final IE lake phytoplankton index had an r^2 of 0.51 and 0.48 with L-CB1 and 2 GIG data respectively Table A.12).

Table A.12 Regression between the IE lake phytoplankton index and Log TP for L-CB1 and 2. Only lakes < 100 µg-l TP were included in the model. Standard error (s.e.) of coefficients are shown.

Type	n	r ²	Intercept	s.e.	Log TP	s.e.	p
L-CB1	298	0.51	1.44336	0.05262	-0.585473	0.03365	<0.0001
L-CB2	92	0.48	1.49456	0.1168	-0.645524	0.07019	<0.0001

Boundary setting

Overview of the approach to boundary setting in the Republic of Ireland

The broad approach to defining the good/moderate boundary in the Republic of Ireland is based on the secondary effects of an increase in total phosphorus and chlorophyll *a* on macrophyte diversity in the context of normative definitions for moderate status outlined in Annex 5 of the WFD (Figure A.9) (Council of the European Communities, 2000). The good/moderate boundary was taken to be approximately 25 µg l⁻¹ TP on the basis that it corresponds with normative definitions in that it is the point where macrophyte diversity starts to decrease therefore resulting in an 'undesirable disturbance to the balance of organisms'. The increase in diversity between 10 and 25 µg l⁻¹ TP may correspond to normative definitions of good status in that the change is not an 'undesirable' one. Figure A.10 reproduced from Allott *et al.* (1998) shows a time-series of charophyte coverage and TP and chlorophyll *a* from Lough Sheelin, Ireland. It indicates that TP concentrations below 20 µg l⁻¹ TP are necessary for the maintenance of extensive charophyte beds. When concentrations reached 40 µg l⁻¹ TP during the 1980s there was

a dramatic reduction in charophyte extent. Free et al. (2006) in Chapter 9, further divide the high alkalinity lake type in Ireland into charophyte 'marl' lakes (typically > 2 meq l-1) and those that are non-marl (typically 0.4 to 2 meq l-1) and provide more specific relationships of use for boundary setting. Such marl lakes may require more conservative boundaries – see section on translation to national types.

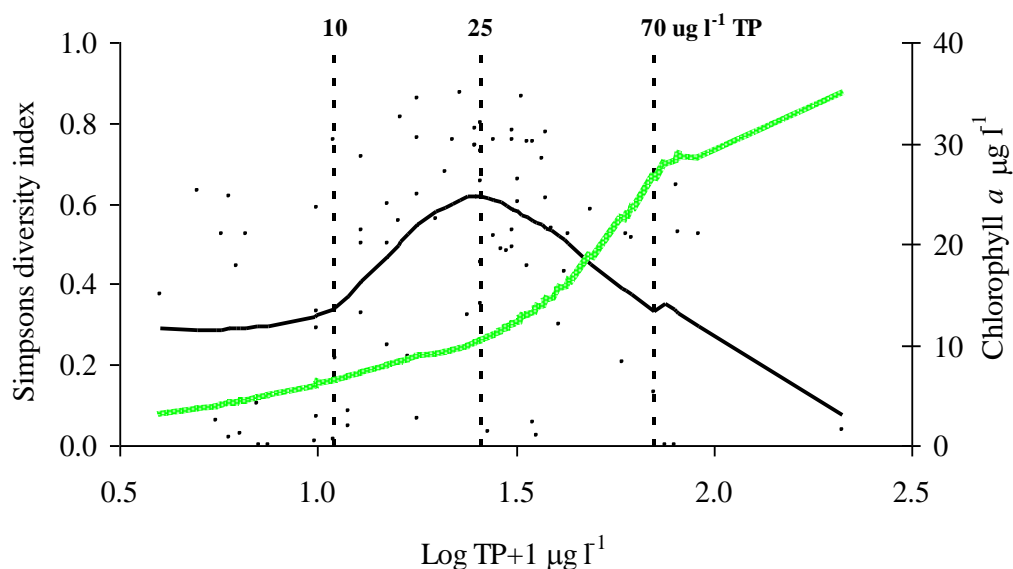
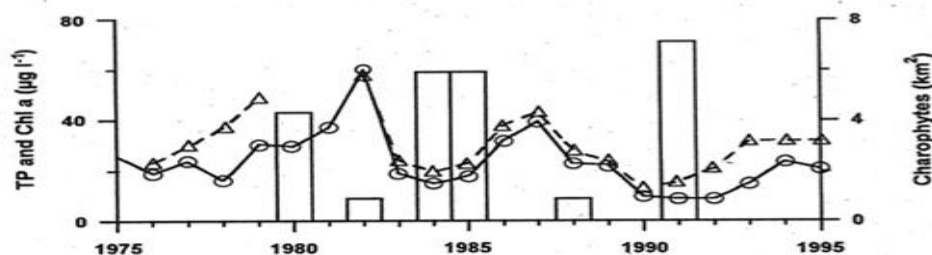

Figure A.9 Relationship between macrophyte diversity (Simpson's diversity index with lowest smoothed line: —), and transformed (Log x+1) TP. Smoothed relationship of chlorophyll a with transformed (Log x+1) TP is overlain (—). Graph refers to lakes > 0.4 meq l-1 only. Selection of TP concentrations, measured mostly in Spring are overlain (- - -).



Graph illustrating the trends in annual average total phosphorus (Δ), annual average chlorophyll a (O) and charophyte distribution (histogram) in L. Sheelin (adapted from Champ, 1993, 1998).

Figure A.10 Graph illustrating the trends in annual average TP (Δ) and annual average chlorophyll a (O) and charophyte distribution (bars) in Lough Sheelin, Ireland (adapted from Champ, 1993, 1998). Reproduced from Allott et al. (1998).

Updating boundary setting for the second round of intercalibration

In the second round of intercalibration it is necessary to ensure that the final IE lake phytoplankton index boundaries are once again set at points relevant to the normative definitions. The approach to this was to set boundaries of chlorophyll *a* and the composition metric in line with points of ecological change relevant to the normative definitions (see above). However, as boundary setting for the two parameters was done separately (chlorophyll *a* in the 1st round and the composition metric in the 2nd), additional validation is desirable for the combined assessment as new boundaries are essentially formed when both normalised parameters are joined to give a final assessment of the BQE phytoplankton. To achieve this, the boundaries of the IE lake phytoplankton index were checked against a model to predict the depth of colonisation of macrophytes. The depth of colonisation responds to a large degree to the increased attenuation of light owing to higher abundance of phytoplankton with eutrophication.

To estimate the reduction in depth of macrophyte colonisation (*Z_c*) with declining status from an NEQR of 1 a sequence of predictive models were applied (Table A.13 and Table A.15). The chlorophyll *a* concentration at each boundary was predicted for each type using a regression with the IE lake phytoplankton index. This chlorophyll *a* at the boundary was used to predict transparency (for a colour of 30 mg l⁻¹ PtCo) which was used to predict the depth of colonisation (Table A.13). The models for L-CB1 and 2 estimated that the depth of colonisation of angiosperms would decrease from 4.45 and 4.48 m for an NEQR of 1 to 3.63 and 3.59 m at the good/moderate boundary. Charophyte depth of colonisation was predicted to decline from 5.37 and 5.42 m for an NEQR of 1 to 3.73 and 3.66 m at the good/moderate boundary. The good/moderate boundary represented a point where there is estimated to be a loss of a third (31-32%) in the depth of colonisation (Table A.15).

The depth of colonisation, as a metric for boundary setting, may not be as relevant in the shallow L-CB2 type as these lakes have a mean depth <3m. However, significant areas of such lakes may have depths greater than 5 m and model predictions, as opposed to field measurements, should therefore serve as a useful guide to boundary setting. In addition, Table A.12 and Table A.14 show that there was no evidence of a significant difference between L-CB1 and 2 in the response of the IE lake phytoplankton index and chlorophyll *a* to pressure (TP). There is therefore some justification for having similar boundaries for the two lake types.

Table A.13 Models used to predict Z_c. Sources: 1&2: intercalibration CBGIG data; 3: Free (2002), 4: Equation 4 Chambers and Kalff (1985), 5: Blindow (1992). A colour value of 30 mg l⁻¹ PtCo was used.

Source	Dependent variable	r ²	Model
1	Log chlorophyll <i>a</i> [µg l ⁻¹ at L-CB1 boundaries	0.89	1.99197+IE lake phytoplankton index*-1.81268
2	Log chlorophyll <i>a</i> [µg l ⁻¹ at L-CB2 boundaries	0.90	2.10221+ IE lake phytoplankton index *-1.95045

3	Log 1+Secchi depth (m)	0.82	1.34495 -0.414109 log (x + 1) colour -0.205299 log (x + 1) chlorophyll a $\mu\text{g l}^{-1}$
4	Zc Angiosperms ^{0.5}		1.33 log Secchi depth + 1.4
5	Log Zc Charophyta	0.83	1.03 log Secchi depth + 0.18

Table A.14 Regression between chlorophyll a $\mu\text{g l}^{-1}$ and Log TP for L-CB1 and 2. Only lakes < 100 $\mu\text{g l}^{-1}$ TP were included in the model. Standard error (s.e.) of coefficients are shown.

Type	n	r ²	Intercept	s.e.	Log TP	s.e.	p
L-CB1	298	0.56	-0.846499	0.09741	1.19814	0.0623	<0.0001
L-CB2	92	0.48	-0.841125	0.2313	1.261	0.1391	<0.0001

Table A.15 Predicted reduction in depth of macrophyte colonisation (Zc) with declining status from an EQR of 1 for L-CB1 and L-CB2 lakes. Sequential predictions are based on application of models 1, 3, 4, 5 for L-CB1 and 2, 3, 4, 5 for L-CB2 and assuming a colour of 30 mg l⁻¹ PtCo (Table A.13).

Type	Boundary	NEQR	Predicted Chl a at NEQR boundary	Predicted Zc Angiosperms	Predicted Zc Charophytes	Predicted % loss of Zc Charophytes from reference
L-CB1	EQR1	1.0	1.51	4.45	5.37	0
L-CB1	High/Good	0.8	3.48	4.08	4.57	15
L-CB1	Good/Moderate	0.6	8.02	3.63	3.73	31
L-CB1	Moderate/Poor	0.4	18.49	3.14	2.93	45
L-CB1	Poor/Bad	0.2	42.60	2.62	2.23	58
L-CB2	EQR1	1.0	1.42	4.48	5.42	0
L-CB2	High/Good	0.8	3.48	4.08	4.57	16
L-CB2	Good/Moderate	0.6	8.55	3.59	3.66	32
L-CB2	Moderate/Poor	0.4	20.99	3.06	2.82	48
L-CB2	Poor/Bad	0.2	51.54	2.50	2.09	62

Translation of intercalibrated boundaries into national types

The intercalibrated types are, of necessity, quite broad and simple to allow for comparisons across the many member states in the CBGIG. In the Republic of Ireland lake typology there are two groups of high alkalinity lakes, those between 0.4 and 2 and those > 2 meq l⁻¹, while the CBGIG considers one broad alkalinity type of lakes > 1 meq l⁻¹. The potential translation of the intercalibrated types into national types is laid out in Table A.16 Of key interest is the need to consider more stringent boundaries for lakes > 2 meq l⁻¹ alkalinity considered to be or have been at some point in the past marl lakes. These lakes typically appear to be more sensitive to pressure than lakes between 0.4 and 2 meq l⁻¹ alkalinity with significant charophyte loss after around 15 µg l⁻¹ TP (compare Figure A.11 below with Figure A.13). It is important to be careful in applying broad L-CB 1 and 2 standards to such lakes as many lakes of this type are protected under the Habitats Directive as they contain lakes of type 3140 - Hard oligo-mesotrophic waters with benthic vegetation of Chara spp and are likely to require more stringent boundaries. Such marl lake types are likely to have been historically more prevalent across Europe in oligotrophic or mesotrophic lakes of high alkalinity situated on limestone. The Joint Nature Conservation Committee (2007) have suggested that TP concentrations below 25 µg l⁻¹ are required for favourable conservation for this 'sub-type' of lake.

||

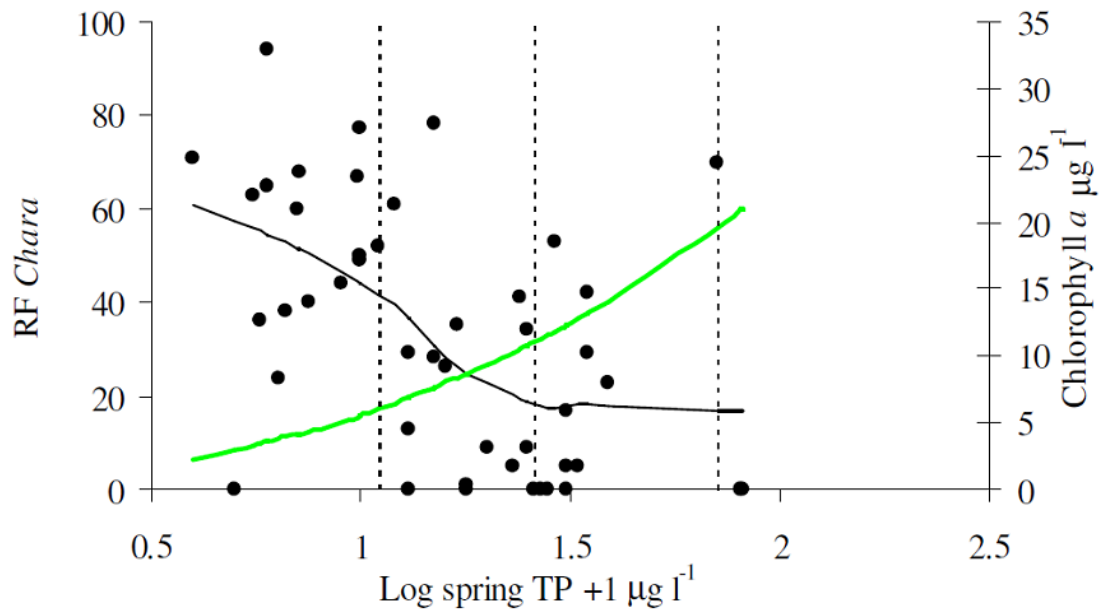

Figure A.11 Relationship between TP (Spring) and the relative frequency of Chara for lakes > 2 meq l⁻¹ CaCO₃ alkalinity. The lowest smoothed relationship between TP and summer chlorophyll a is overlain (—). Dashed lines represent 10, 25 and 70 µg l⁻¹ TP. Black continuous lines represent the lowest smoothed relationship between TP and the selected metric.

Table A.16 List of lake types in Ireland and potential use for translation of intercalibrated types. *indicates that lower boundaries may be needed for marl lakes, typically > 2 meq l⁻¹. Many of the remaining types are being intercalibrated in the NGIG.

IE Lake Type	Altitude m	Alkalinity meq l ⁻¹	Mean depth m	Area km ²	L-CB Type
1	<200	<0.4	<4	<0.5	
2	<200	<0.4	<4	>0.5	
3	<200	<0.4	>4	<0.5	
4	<200	<0.4	>4	>0.5	
5	<200	0.4 - 2	<4	<0.5	L-CB2
6	<200	0.4 - 2	<4	>0.5	L-CB2
7	<200	0.4 - 2	>4	<0.5	L-CB1
8	<200	0.4 - 2	>4	>0.5	L-CB1
9	<200	>2	<4	<0.5	L-CB2*
10	<200	>2	<4	>0.5	L-CB2*
11	<200	>2	>4	<0.5	L-CB1*
12	<200	>2	>4	>0.5	L-CB1*
13	>200	-	-	-	

References

Allott, N., Free, G., Irvine, K., Mills, P., Mullins, T.E., Bowman, J.J., Champ, W.S.T., Clabby, K.J. & McGarrigle, M.L. (1998) Land use and aquatic systems in the Republic of Ireland. *Studies in Irish Limnology*, 1-18.

Blindow, I. (1992) Decline of charophytes during eutrophication: comparison with angiosperms. *Freshwater Biology*, 28, 9-14.

Chambers, P.A. & Kalff, J. (1985) Depth distribution and biomass of submersed aquatic macrophyte communities in relation to Secchi depth. *Canadian Journal of Fisheries and Aquatic Sciences*, 42, 701-709.

Council of the European Communities (2000) Directive 2000/60/EC of the European Parliament and of the Council of 23 October 2000 establishing a framework for community action in the field of water policy. . *Official Journal of the European Communities*, L 327, 1-72.

EC (2008) Commission Decision of 30 October 2008 establishing, pursuant to Directive 2000/60/EC of the European Parliament and of the Council, the values of the Member State monitoring system classifications as a result of the intercalibration exercise. *Official Journal of the European Union*, L 332 20-44.

Free, G. (2002) *The relationship between catchment characteristics and lake chemistry in the Republic of Ireland*. PhD, Trinity College Dublin, Dublin.

Free, G., Little, R., Tierney, D., Donnelly, K. & Caroni, R. (2006) A reference based typology and ecological assessment system for Irish lakes. Preliminary investigations., pp. 266. Wexford, Ireland.

Irvine, K., Allott, N., deEyto, E., Free, G., White, J., Caroni, R., Kennelly, C., Keaney, J., Lennon, C., Kemp, A., Barry, E., Day, S., Mills, P., O' Riain, G., Quirke, B., Twomey, H., Sweeney, P. (2001) *Ecological assessment of Irish lakes*. Environmental Protection Agency Wexford.

Joint Nature Conservation Committee (2007) *Second Report by the UK under Article 17 on the implementation of the Habitats Directive from January 2001 to December 2006*. JNCC, Peterborough.

Poikane, S. (2008) Water Framework Directive Intercalibration Technical Report - Part 2: Lakes. pp. 185. European Commission.

REFCOND (2003) *Common implementation strategy for the Water Framework Directive (2000/60/EC), guidance document 10, river and lakes – typology, reference conditions and classification systems*. Office for Official Publications of the European Communities, Luxembourg.

A.7 The Netherlands (NL)

Abundance

Phytoplankton abundance is based on the vegetative season (1 April – 1 October) averaged chlorophyll-a concentration. For the class boundaries NL use the following values within the band width as agreed in the 1st phase of intercalibration (2007) were used initially (see table below) For LCB1, the class boundaries were slightly adjusted during phase 2 (see section on harmonization).

Table A.17 Chlorophyll-a class boundaries agreed in the 1st phase of intercalibration (chl-a, µg/l)

	Ref	H/G	G/M	M/P	P/B
LCB1	3.2	5.8	10	20	40
LCB2	6.8	10.8	23	46	96

Taxonomic composition

Sampling and analysis

In alkaline, meso- and eutrophic lakes, samples are taken four to six times during the vegetative season (April-September) at regular intervals. In shallow lakes samples are taken from the upper 1 m using a bottle or a tube sampler, in deeper lakes the whole epilimnion is sampled using a water samples according to Ruttner. Samples are stored in 1 l bottles and preserved with Lugol solution. Quantitative analyses are carried out using an inverted microscope, according to NEN-EN 15204:2006, at magnifications of 200-

600×. As measure of abundance either cells or individuals (colonies, filaments) are counted depending on the species. Taxa are identified to the species level.

Assessment

Originally two metrics were developed, one, evaluating bloom types, as a measure of anthropogenic disturbance and another, evaluating Desmid sensitivity types, as a measure of naturalness/low disturbance. The results of both were averaged to yield the final assessment of phytoplankton taxonomic composition. The latter metric, however, was judged insufficiently underpinned leaving us with the bloom metric only.

In the bloom metric a number of bloom types are distinguished, ranging from a massive bloom of *Planktothrix agardhii*, via blooms of e.g. *Scenedesmus*, *Anabaena*, *Botryococcus*, to blooms of *Dinobryon* and *Peridinium* (Table A.18). Blooms are defined by a bloom specific density criterion stated in number of cells, filaments or colonies per ml. To each bloom a specific EQR is assigned, ranging from 0.1 to 0.7, depending on its prevalence in relation to eutrophication. If more than one type of bloom can be distinguished the one with the lowest EQR is decisive. If no bloom can be distinguished either no EQR (NL1) or an EQR of 0.7 is given. This has been a matter of discussion.

Each of the four to six samples is analysed and assessed. The final EQR for the lake is the arithmetic mean of the EQR's of the separate samples.

Overall assessment

The overall assessment is based on the average of abundance and taxonomic composition. If the metric for taxonomic composition could not be calculated (when none of the blooms occurred), the overall assessment is based on abundance only.

Reference and boundary setting

Reference conditions for chlorophyll-a were originally based on reference concentrations for total-P, which is the main limiting factor for algal growth in Dutch freshwater lakes, and the chlorophyll-a : total-P ratio in lakes under reference conditions. This involved several steps:

1. The reference total-P concentrations were based on the relationship found by Vighi & Chiaudani (1985) between total-P on one hand and lake alkalinity and mean depth on the other.
2. The chlorophyll-a : total-P ratio's were determined for lakes with total-P concentrations below twice the reference total-P concentration, where a distinction was made between lakes with mean depth >3m and lakes with mean depth <3m, corresponding to LCB1 and LCB2.
3. The reference chlorophyll-a concentrations were based on the median value of the chl:P ratio's.

Table A.18 Bloom types and corresponding EQR distinguished in the Dutch metric.

No	Type of bloom	Bloom criterium		EQR
		n per ml	mm ³ per ml	
1	Persistent bloom of <i>Planktothrix agardhii</i>	> 10.000 filaments	30.68	0.1
2	Bloom of thin filamentous bluegreen algae (LPP-group)	> 20.000 filaments	19.64	0.2
3	Bloom of <i>Stephanodiscus hantzschii</i>	> 30.000 cells	13.62	0.2
4	Very dense bloom of <i>Microcystis</i> spp. with massive scums	> 100.000 cells	3.30	0.2
5	Species poor bloom of <i>Scenedesmus</i> spp.	> 20.000 cells	1.60	0.2
6	Temporary bloom of <i>Planktothrix agardhii</i>	4.000-10.000 filaments	12.27	0.3
7	Bloom of <i>Aphanizomenon gracile</i>	> 2.000 filaments	6.35	0.4
8	Species rich bloom of small chlorococcales	> 20.000 cells	0.40	0.4
9	Bloom of <i>Microcystis</i> spp. with no or minor scum formation	20.000-100.000 cells	0.68	0.4
10	Bloom of small cryptophyceans	> 10.000 cells	1.20	0.4
11	Bloom of <i>Cryptomonas</i>	> 2.000 cells	3.72	0.4
12	Bloom of <i>Skeletonema</i> spp.	> 10.000 cells	2.00	0.4
13	Bloom of <i>Diatoma tenuis</i>	> 6.000 cells	2.52	0.4
14	Species rich bloom of small chlorococcales (ACM-group)	> 10.000 colonies	1.20	0.5
15	Bloom of <i>Aphanizomenon flos-aquae</i> with possible scum formation	> 2.000 filaments	8.83	0.5
16	Bloom of <i>Anabaena</i> spp.	> 800 filaments	5.12	0.5
17	Bloom of <i>Aulacoseira granulata</i> or <i>A. ambigua</i>	> 10.000 cells	7.30	0.5
18	Short bloom of <i>Aphanizomenon flos-aquae</i> with small chance of scum formation	1.000-2.000 filaments	4.42	0.6
19	Bloom of <i>Microcystis wessenbergii</i>	> 20.000 cells	1.28	0.6
20	Bloom of <i>Woronichinia naegeliana</i>	> 20.000 cells	0.50	0.6
21	Bloom of <i>Chrysochromulina parva</i>	> 10.000 cells	1.10	0.6
22	Bloom of <i>Cyclotella radiosa</i>	> 1.000 cells	0.90	0.6
23	Surface "scum" of <i>Gloeotrichia natans</i>			0.6
24	Surface "scum" of <i>Aphanothece stagnina</i>			0.6
25	Bloom of <i>Aulacoseira islandica</i> or <i>A. subarctica</i>	> 10.000 cells	8.85	0.6
26	Bloom of <i>Cyclotella ocellata</i>	> 1.000 cells	0.34	0.7
27	Bloom of <i>Botryococcus</i> sp.	> 100 colonies	0.85	0.7
28	Bloom of <i>Synura</i> spp.	> 1.000 cells	0.80	0.7
29	Bloom of <i>Dinobryon</i> spp.	> 1.000 cells	0.16	0.7
30	Bloom of thecate dinoflagellates (<i>Ceratium</i>)	> 100 cells	2.80	0.7
31	Bloom of thecate dinoflagellates (<i>Peridinium</i>)	> 100 cells	1.20	0.7
32	...			
39	...			
40	...			
99	No bloom			(0.7)

The High-Good boundary for chlorophyll-a was originally calculated from the total-P and the chl:P ratio at the High-Good boundary for total-P.

Reference value and class boundaries for chlorophyll-a were later on adjusted based on the results of the 1st phase of intercalibration (see above), and finally adjusted during the 2nd phase of intercalibration based on combination with the taxonomic metric (see below).

The assignment of EQR's to bloom types is based on the prevalence of bloom types at specific levels of eutrophication (i.e. levels of phosphorus) and expert judgement. It is assumed that at reference conditions none of the specified bloom types occur, and that chlorophyll-a concentration is within the band width for reference conditions.

Harmonisation during 2nd phase of intercalibration

During the harmonization phase of the 2nd phase of intercalibration, based on the combined assessments of the abundance (chlorophyll-a) and taxonomic metric, the chlorophyll-a class boundaries were slightly adjusted for LCB1, but remain within the agreed band width:

Ref	3.8 ug/l
H/G	7.0
G/M	12
M/P	24
P/B	48

For LCB2, no adjustment with respect to the values agreed after phase 1 was needed.

A.8 Poland (PL)

Authors: A. Hutorowicz and A. Pasztaleniec

Summary

This document outlines how ecological status of lake is assigned for the biological quality element phytoplankton and how reference conditions and boundaries have been assigned in Poland. The Polish phytoplankton assessment method is based on multi-metric index (PMPL) which includes three mandatory metrics: "chlorophyll *a*", "total biomass" and "biomass of Cyanoprokaryota". All the single metrics and PMPL index value ranges from 0 to 5 where 0 indicates the best status and 5 the worst status. The final PMPL can be transformed to a normalized ecological quality ratio (EQR). The phytoplankton assessment method differentiates the lake types "stratified" and "polymictic" as well as subdivisions into lakes characterised by high (>2) and low (<2) ratio of volume of the lake to catchment area (VQ, Schindler's ratio). The PMPL was also tested against the total phosphorus, total nitrogen and Secchi disc visibility as the pressure measures.

Introduction

In Poland, the ecological status for the biological quality element (BQE) lake phytoplankton is assessed using three parameters: chlorophyll *a* concentration, the total biomass of phytoplankton and the total biovolume of Cyanoprokaryota. Three metrics are calculated separate formulas: "chlorophyll *a*" – Y_{Ch} , "total biomass" – Y_{Bm} , and "biomass of Cyanoprokaryota" – Y_{CY} , so that their boundaries and class widths are same scale and then averaged (Figure A.12). The boundaries of "chlorophyll *a*" metric are adapted from earlier established chlorophyll *a* concentration boundaries for ecological status assessment of Polish lakes (Ordinance of the Minister of Environment from 20th August 2008). To the aim of the standardisation of single metrics and its averaging, the approach applied in German ecological status assessment system (Mischke et al. 2008) was used.

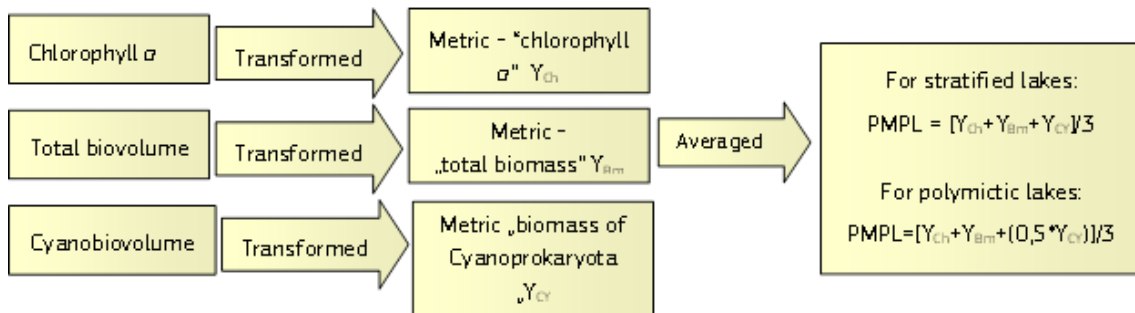

Figure A.12 Chlorophyll a (Y_{Ch}), phytoplankton total biomass (Y_{Bm}) and biomass of Cyanoprokaryota metrics are calculated from proper equations and averaged to provide the Phytoplankton Metrics for Polish Lakes (PMPL) Index value.

Determination of lake type

The Polish phytoplankton assessment method was worked out for lowland lakes with alkalinity above 1 meq l^{-1} . The applied typology is based on the simplified abiotic typology of Polish lakes proposed by Kolada et al. (2005) and includes four types of lakes (Table A.19). During intercalibration process, PMPL index was used for two CBGIG lake types (Table A.20).

Table A.19 Overview of abiotic lake types applied in phytoplankton based assessment method (PMPL) in Poland. *Ratio of the total catchment's area (m^2) to the volume of lake

Type of mixing	ratio of volume of the lake to catchment area (VQ, Schindler's ratio)
Stratified	<2
	>2
Polymictic	<2
	>2

Table A.20 Central Baltic GIG lake types intercalibrated by Poland

Type	Lake Characterisation	Altitude m	Mean depth m	Alkalinity meq l^{-1}
L-CB1	Lowland, shallow, calcareous	<200	3 - 15	> 1
L-CB2	Lowland, very shallow, calcareous	<200	<3	> 1

Sampling

Phytoplankton is sampled during the growing season (March-October) from the deepest part of the lake, spatial replication depends on lake size and morphology. It is recommended to take samples four times (during spring water mixing, early summer, late summer, autumn). The detailed procedure of sampling is presented in Table A.21. Integrated samples should be taken from euphotic zone or epilimnion - stratified lakes; whole water column - polymictic lakes.

Table A.21 Recommended terms for chlorophyll *a* and phytoplankton sampling in Polish assessment method (PMPL).

Metrics	Type of lake mixing	
	stratified	polymictic
„Chlorophyll <i>a</i> ”	March-May (1 sampling) June-September (2 samplings) October (1 sampling)	March-May (1 sampling) June-September (2 samplings) October (1 sampling)
„Total biomass”	March-May (1 sampling) June-September (2 samplings) October (1 sampling)	March-May (1 sampling) June-September (2 samplings) October (1 sampling)
„Biomass of Cyanoprokaryota”	15 July - 15 September (at least 1 sampling)	04 June - 30 September (at least 2 samplings)

Reference values

Reference values of parameters for all abiotic types of lakes were established by “best of existing” method. The reference sites were chosen as the 10th percentile of the value of each parameter distribution regarding type of lake. The boundary value of reference status was set as the median of those. In the case of chlorophyll *a* concentration and total phytoplankton biovolume, means from growing season were taken into calculations, for biovolume of Cyanoprokaryota – only summer data were used.

Table A.22 Boundary values of reference status.

Parameter	stratified lakes		polymictic lakes	
	VQ<2	VQ>2	VQ<2	VQ>2
chlorophyll <i>a</i> [$\mu\text{g l}^{-1}$]	3.1	4.8	5.7	5.9
total biovolume [mg l^{-1}]	0.54	0.74	0.80	1.1
biovolume of Cyanoprokaryota [mg l^{-1}]	0.37	0.55	1.23	

Metric “Chlorophyll *a*”

Chlorophyll *a* (Chl-*a*) is determined following extraction using spectrophotometric analysis.

The method of setting chlorophyll *a* boundaries was outlined by Soszka et al. (2008). The High/Good boundary was established as 75th percentile of mean chlorophyll *a* concentration at reference sites, boundaries of the other classes were set as quartiles of the entire range of chlorophyll *a* variability at logarithmic scale. Boundary Chl-*a* values for ecological status classes are presented in Table A.23.

Table A.23 Boundaries for ecological status classes of chlorophyll *a* concentration ($\mu\text{g l}^{-1}$).

Type of lake mixing	VQ	High/ Good	Good/ Moderate	Moderate/ Poor	Poor/ Bad
stratified	<2	5.2	7.7	11.1	16.3
	>2	7.1	12.8	21.4	32.8
polymictic	<2	10.0	19.1	30.0	42.1
	>2	10.1	22.7	40.5	67.9

Metric "chlorophyll *a*" - $Y_{\text{Chl-a}}$ is calculated using Equation 1 or 2 (depending on lake's type), where the $\text{Chl-a}_{\text{obs}}$ is the mean chlorophyll value observed during growing season in $\mu\text{g l}^{-1}$ and k, z, m are coefficients specific for each type of lake (Table A.24).

Equation 1: for stratified lakes with VQ <2 or >2 ; polymictic lakes with VQ <2

$$Y_{\text{Chl-a}} = k + z * \text{Chl-a}_{\text{obs}} + m * \text{Ln}(\text{Chl-a}_{\text{obs}})$$

or

Equation 2: for polymictic lakes with VQ >2

$$Y_{\text{Chl-a}} = k + z * \text{Chl-a}_{\text{obs}} - m * \text{Chl-a}_{\text{obs}} * \text{Ln}(\text{Chl-a}_{\text{obs}})$$

Metric value ($Y_{\text{Chl-a}}$) smaller than 0 should be set to 0, and value larger than 5 should be set to 5 for further PMPL calculations.

Table A.24 The values of coefficients k, z and m for equation 1 and 2.

Type of lake mixing	VQ	k	z	m
stratified	<2	-3.2698	0	2.6081
	>2	-1.8555	0.0369	1.3293
polymictic	<2	-1.1252	0.0649	0.6414
	>2	-0.3334	0.2147	0.0357

Metric "Total biomass"

Poland has chosen total phytoplankton biovolume as the second biomass metric for ecological status assessment method. Phytoplankton samples are counted using the Utermöhl technique and total biovolume is calculated from the sum of the biovolumes

of each taxon in the sample (cell number x specific cell volume). Boundaries of total biovolume were established based on the correlation between TP, chlorophyll *a*, SD and biomass following Carlson's procedure (Carlson 1977), the earlier adopted chlorophyll *a* classification system and information from Polish scientific literature (Hillbricht-Ilkowska and Wiśniewski, 1994). For example, for stratified lakes characterised by Schindler's ratio >2, Carlson's index value = 70 was treated as P/B boundary which responds to about 20 mg l⁻¹ of total phytoplankton biovolume. This value is regarded in Polish scientific literature as the boundary of high trophy for dimictic lakes (Hillbricht-Ilkowska and Wiśniewski, 1994). Then, the frequency of particular total biovolume values within chlorophyll *a* boundary concentration between P/B status was compared. Finally, the value 21,9 mg l⁻¹ was determined. The other boundaries were established using the distribution of total biovolume data subsequent percentiles (75, 50, 25). Analogous procedure was used for other abiotic types of lakes.

In this way designated classes were verified at partly independent database using the programme "DIVA" of numeric classification (Henrion et al. 1988) which constructs the dendrogram by the method of separating a set of objects according to the criterion of attaining a minimum of variance in the groups formed. In the group of lakes characterized by the lowest TP (10-82 µg l⁻¹) and lowest biovolume of phytoplankton, the mean value was 27.9 µg TP l⁻¹; 2.11 mg l⁻¹ and 75th percentile - 0.35 µg TP l⁻¹; 1.93 mg l⁻¹ respectively. The H/G boundary reflects the average value of the 75th percentile of these data. In the 2th group with similar TP concentration (12-78 µg l⁻¹) the value of biovolume of phytoplankton was twice as big (2.34-4.35 mg l⁻¹). The G/M boundary reflects the average value of the 75th percentile of these data (Figure A.13).

Verified boundaries of total phytoplankton biovolume are presented in Table A.25.

Table A.25 Boundaries for ecological status classes of total biovolume (mg l⁻¹).

Type of lake mixing	VQ	High/Good	Good/Moderate	Moderate/Poor	Poor/Bad
stratified	<2	1.1	2.4	5.2	11.3
	>2	1.2	3.2	8.3	21.9
polymictic	<2	1.8	4.6	11.6	29.3
	>2	1.9	5.3	14.5	29.1

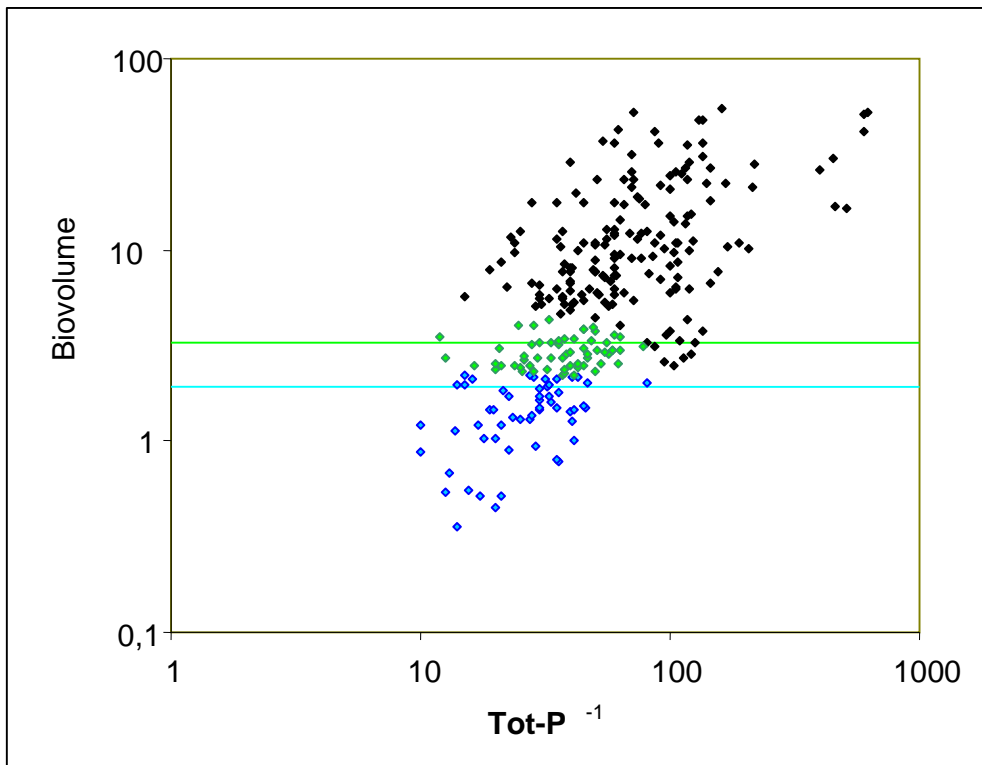

Figure A.13 Total biovolume (mg l^{-1}) versus total phosphorus Tot-P ($\mu\text{g l}^{-1}$) ordination for stratified lakes, with $\text{VQ} > 2$. Dots are mean values from summer data for each year (2005-2009). Blue dots represent samples from lakes in high ecological status, green dots – in good status lakes, black dots are impacted lakes. Horizontal blue line gives the 75th percentile of biovolume from lakes in high ecological status (=1.92). Green horizontal line gives the 75th percentile of biovolume from lakes in good status lakes (=3.28).

Following the application of boundaries, the metric “total biomass” Y_{Bm} is calculated using Equation 3 or 4 (depending on lake’s type), where the B_{obs} is the observed growing season mean biovolume value in mg l^{-1} and k, z, m are specific for abiotic type of lakes coefficients (Table A.26).

Equation 3: for stratified lakes with $\text{VQ} < 2$ or > 2 ; polymictic lakes with $\text{VQ} < 2$

$$Y_{\text{Bm}} = k + m \cdot \ln(B_{\text{obs}})$$

or

Equation 4: for polymictic lakes with $\text{VQ} > 2$

$$Y_{\text{Bm}} = k + m \cdot \ln(B_{\text{obs}}) + z \cdot B_{\text{obs}} + o \cdot \sqrt{B_{\text{obs}}}$$

Metric value (Y_{Bm}) smaller than 0 should be set to 0, and value larger than 5 should be set to 5 for further PMPL calculations.

Table A.26 The values of coefficients k, z and m for equation 3 and 4.

Type of lake mixing	VQ	k	m	z	o
stratified	<2	0.8727	1.2900	0	0
	>2	0.8135	1.0325	0	0
polymictic	<2	0.3778	1.0720	0	0
	>2	2.9511	0	0.0541	-2.8344

Metric "Biomass of Cyanoprokaryota"

Numerical classification of all 133 of lakes-years data of Cyanoprokaryota biovolume in Polish lakes in the years 2008-2009. Analysis using the "DIVA" program indicated lack of significant correlation between biovolume of Cyanoprokaryota and total phosphorus (TP) concentrations (Figure A.14). In the group of lakes characterized by the lowest TP (10-39 $\mu\text{g l}^{-1}$) mean Cyanoprokaryota biovolume was 0.35 mg l^{-1} , 75th percentile - 0.45 mg l^{-1} ; but in the group with similar mean value of Cyanobacterai biovolume 0.42 mg l^{-1} the TP concentration was twice as big (40-77 $\mu\text{g l}^{-1}$). In the 3th group with similar to the first group TP concentration (12-56 $\mu\text{g l}^{-1}$) – mean value was 2.4 mg l^{-1} and 75th percentile 2.83 mg l^{-1} . In the much higher concentrations of TP (79-152 $\mu\text{g l}^{-1}$), mean values of Cyanoprokaryota was only 2,97 mg l^{-1} , 75th percentile - 3.81 mg l^{-1} .

The 90th percentile of Cyanoprokaryota biovolume from lakes in high ecological status set as was similar to the established HG boundary (=0.84) (Figure A.14). Green horizontal line gives the 50th percentile of Cyanoprokaryota biovolume from the lakes in good status (=2.31).

Table A.27 Boundaries for ecological status classes of biovolume of Cyanoprokaryota (mg l^{-1}) (when proportion of Cyanoprokaryota in the total phytoplankton biomass is equal 100%)

Type of lake mixing	VQ	High/Good	Good/Moderate	Moderate/Poor	Poor/Bad
stratified	<2	0.6	1.1	2.3	4.7
	>2	0.8	1.9	4.8	12.1
polymictic		0.93	2.3	5.7	13.9

Metric "Biomass of Cyanoprokaryota" - Y_{CY} is calculated using 5 or 6 (depending on lake's type), where the B_{CYobs} is the mean biovolume of Cyanoprokarota value observed during summer season in mg l^{-1} , B_{Phobs} is the mean total phytoplankton biovolume observed during summer period and k, z, m are coefficients specific for each type of lake (Table A.28).

Equation 5: for stratified lakes

$$Y_{CY} = m * \ln \left[\frac{B_{CYobs} + B_{CYobs} * \left(\frac{B_{CYobs}}{B_{Phobs}} \right)}{2} \right] + k$$

or

Equation 6: for polymictic lakes

$$Y_{CY} = m \times \ln B_{CY} + k$$

Metric value (Y_{CY}) smaller than 0 should be set to 0, and value larger than 5 should be set to 5 for further PMPL calculations.

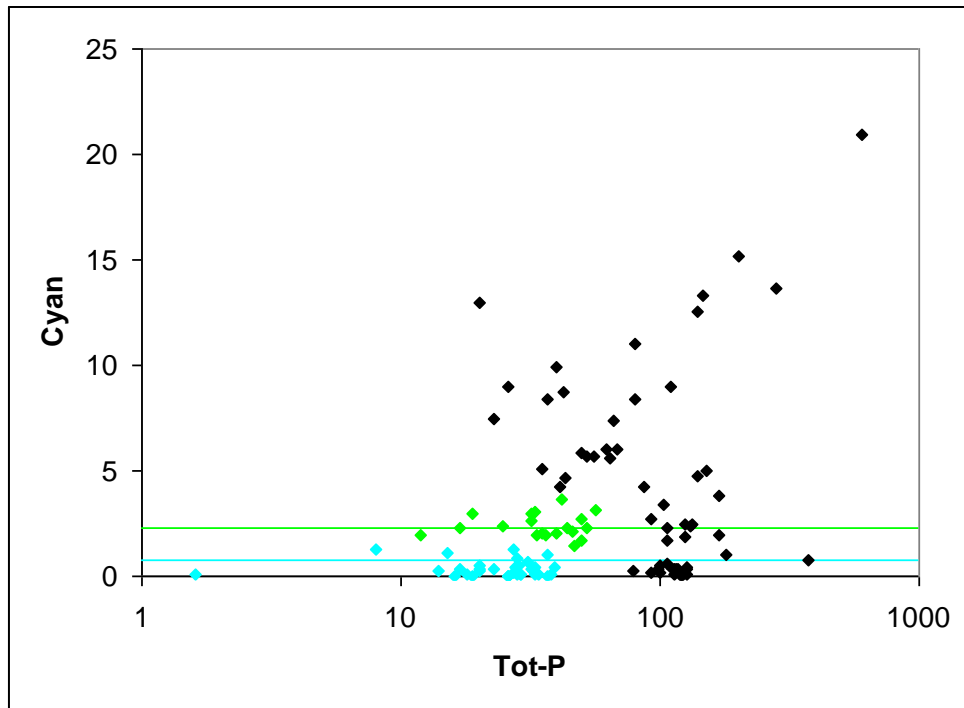

Figure A.14 Cyanoprokaryota biovolume ($mg\ l^{-1}$) against total P ($\mu g\ l^{-1}$) for stratified lakes, with $VQ > 2$. Dots are values from summer data for each year (2008-2009). Blue dots represent samples from lakes in high ecological status, green dots from lakes in good status, black dots are impacted lakes. Horizontal blue line gives the 90th percentile of Cyanobacteria biovolume from the lakes in high ecological status (=0.84). Green horizontal line gives the 50th percentile of Cyanoprokaryota biovolume from the lakes in good status (=2.31).

Table A.28 The values of coefficients k and m for equation 5 and 6.

Type of lake mixing	VQ	k	m
stratified	<2	1.8112	1.4113
	>2	1.2835	1.0898
polymictic		1.0803	1.1072

Calculation of PMPL index and EQR

Phytoplankton Metric for Polish Lakes (PMPL) is the average of three indices. To calculate the single parameter values the three obtained indices must be average according to the following formulas.

For stratified lakes:

$$\text{PMPL} = [Y_{\text{Ch}} + Y_{\text{Bm}} + Y_{\text{Cy}}]/3$$

For polymictic lakes:

$$\text{PMPL} = [Y_{\text{Ch}} + Y_{\text{Bm}} + (0,5 * Y_{\text{Cy}})]/2.5$$

The final PMPL value assigns the lake to the ecological status class according the class boundaries presented in Table A.23.

PMPL index can be transformed to normalized ecological quality ratio using the equation:

$$y = -0.2 * \text{PMPL} + 1$$

Table A.23 lists the ranges of PMPL values which are equal to the five status classes of EU-WFD and their normalized ecological quality ratio (EQR).

Table A.29 Boundaries of PMPL and EQR for ecological status classes

PMPL	EQR	Ecological Status Class
0-1	0.8-1.0	high
1-2	0.6-0.8	good
2-3	0.4-0.6	moderate
3-4	0.2-0.4	poor
4-5	0-0.2	bad

Testing results of PMPL

Figure A.15 presents the relationships and correlation coefficients between EQR calculated based on Phytoplankton Metric for Polish Lakes (PMPL) and pressure parameters (TP, TN, SD).

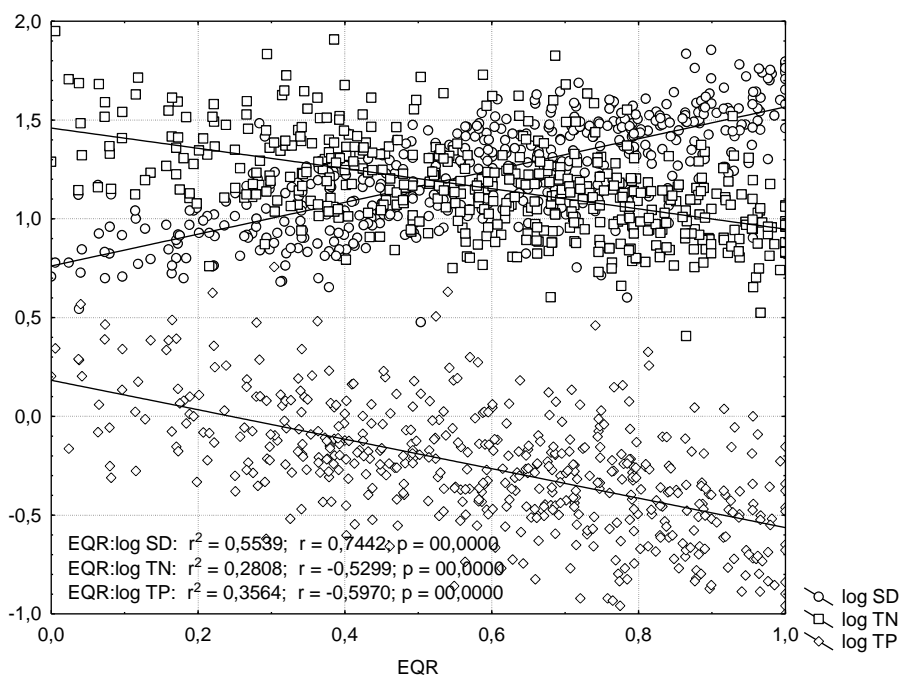

Figure A.15 Relationship between phytoplankton EQR and pressure parameters.

References

- Carlson, R.E., 1977. A trophic state index for lakes. *Limnol. Oceanogr.* 22, 361-369.
- Henrion R., Henrion A., Henrion G. 1988. BASIC-Programm DIVA zur divisiven Clustering nach dem Varianzkriterium. *Acta Hydrochim. hydrobiol.* 16: 491-497.
- Hillbricht-Ilkowska, A., Wiśniewski, R.J., 1994. Zróźnicowanie troficzne jezior Suwalskiego Parku Krajobrazowego i jego otuliny. Stan obecny, zmienność wieloletnia, miejsce w klasyfikacji troficznej jezior. In: Hillbricht-Ilkowska, A., Wiśniewski, R.J. (Eds.), *Jeziora Suwalskiego Parku Krajobrazowego*. Wydawnictwo PAN, Zeszyty Naukowe 7, Wrocław-Warszawa-Kraków, pp. 181-200.
- Kolada A, Soszka H., Cydzik D., Gołub M., 2005. Abiotic typology of Polish lakes. *Limnologica* 35: 145-150.
- Mischke, U., Riedmüller, U., Hoehn, E., Schönfelder, I., Nixdorf, B., 2008. Description of the German system for phytoplankton-based assessment of lakes for implementation of the EU Water Framework Directive (WFD), In: Mischke, U. & Nixdorf, B. (eds.): *Bewertung von Seen mittels Phytoplankton zur Umsetzung der EU-Wasserrahmenrichtlinie*, BTUC-AR 2/2008. Bad Saarow, Freiburg, Berlin. University of Cottbus, ISBN 978-3-940471-06-2, Aktuelle Reihe 2/2008: 117-146.
- The Ordinance of the Minister of Environment from 20th August 2008 on the classification of surface water bodies (Journal of Laws [Dz.U] No. 162, item 1008).

Soszka, H., Gołub, M., Kolada, A., Cydzik, D., 2008. Chlorophyll a based assessment of Polish lakes. *Verh. Internat. Verein. Limnol.* 30 (3), 416-418.

A.9 United Kingdom (UK)

Sampling and analysis

Phytoplankton is sampled three times a year, in June/July and in August-September. Identification is done at the order level. The abundance of taxa is expressed in biovolume per ml.

Samples are taken from the lake outflow, or from the shore using throw bottles to sample below the surface. Samples for chlorophyll a are taken monthly throughout the year and are analysed at a central laboratory. Samples for taxonomic composition are taken monthly from July to September and preserved in Lugol's solution and stored in the dark. The cells are counted with an inverted microscope by trained analysts⁴. Identification of taxa is generally to species, using a standardised list of c240 taxa. Size measurements of a sub-sample of cells are taken to calculate bio-volume ($\mu\text{m}^3 \text{ml}^{-1}$).

Assessment

Assessment of phytoplankton taxonomic composition will be based on the use of the percentage of nuisance cyanobacteria, by biovolume within the lake phytoplankton.

The assessment is based on the average of three samples collected during the summer period, preferably over a three year period.

Percentage cyanobacteria is calculated based on biovolume. Certain cyanobacteria are excluded from the calculation. These are all the Chroococcales with the exception of *Microcystis*.

Total biovolume is also considered and is used to provide a threshold below which a lake cannot be at worse than Good Ecological Status regardless of the proportion of cyanobacteria in the samples counted. This value is set at 0.5 mg/l. Where a lake has <0.5 mg/l total biovolume, but has a % cyanobacteria that exceeds the H/G boundary (5%) the EQR is set to the mid point of Good class (0.89)

The EQR is calculated from the following equation:

$$EQR = \frac{(100 - Obs\%)}{(100 - 2\%)}$$

Summary

⁴ Analysts are subject to ring-tests and attend regular training sessions to ensure that their competency level is maintained

Three groups of indicators are used, phytoplankton abundance, taxonomic composition and the likelihood of cyanobacteria blooms.

Phytoplankton abundance is measured by proxy using chlorophyll a as a surrogate. The metric used is the mean⁵ annual chlorophyll a concentration, derived from samples collected monthly between January and December⁶.

Taxonomic composition is measured using the Plankton Trophic Index (PTI) calculated from samples collected monthly between July and September⁷.

The likelihood of cyanobacteria blooms is calculated from the bio-volume of cyanobacteria present. The metric used is the median bio-volume of cyanobacteria in samples collected monthly between July and September.

Each of these metrics is converted to an EQR, using modelled estimates of reference conditions. These EQR are then normalised, so that the boundaries of each metric are on the same scale (0.8, 0.6, 0.4, 0.2), and then combined by averaging. The cyanobacteria EQR is excluded from the average if it is greater than the average of the chlorophyll and PTI EQR.

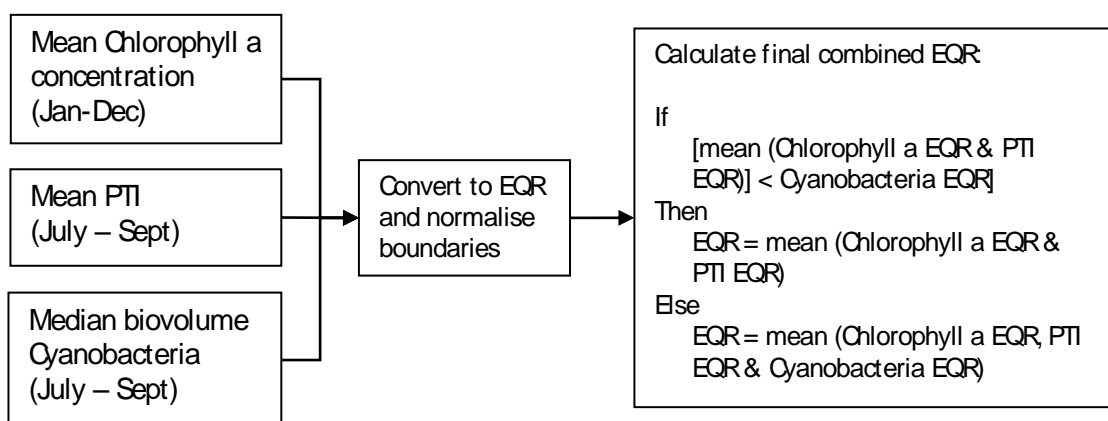

Biomass Metric - Chlorophyll a

The biomass of phytoplankton is assessed by proxy using the chlorophyll a concentration as a surrogate. The annual geometric mean chlorophyll a concentration (*Chl*) is converted to an EQR using a modelled reference value (equation 1)

⁵ Values are log transformed prior to averaging, so that the mean is a geometric mean. This allows uncertainty estimates to be made.

⁶ January – December represents the growing season in the UK; in parts of the country significant biomass of phytoplankton are present in the winter months.

⁷ July – September represents the late summer which is the most sensitive season for phytoplankton composition response to nutrient enrichment.

$$EQR_{Chl} = \frac{Chl_{Ref}}{mean(\log_{10}(Chl))} \quad (1)$$

Reference Chlorophyll

The reference chlorophyll a is predicted from a multiple regression model derived from 59 reference lakes (equation 2a).

$$Chl_{Ref} = 10^{\left(0.223 + 0.166 \times \log(Alk) + 0.684 \times \sqrt{1/Depth}\right)} \quad (2a)$$

Where

Chl = geometric annual mean chlorophyll a concentration (µg/l)

Alk = reference alkalinity (mEq/l) (minimum value of 0.005)

Depth = reference mean depth (m) (minimum value of 1.0)

The predicted reference chlorophyll a concentration is compared to a range of reference chlorophyll a concentrations which were set during Phase 1 of the intercalibration process (Poikane 2010). Where a value falls outside of this range, it is truncated to the upper or lower range limit. For lake types that have not been intercalibrated, reference chlorophyll values are constrained within the range of 1.3 – 6.0 µg/l.

As the mean reference chlorophyll a values set during intercalibration are arithmetic, they are first transformed⁸ to geometric means using a standard deviation estimated from a large EU data set (WISER), see equation 2b

$$GeoChl = ArithChl / e^{(0.5 \times (2.323 \times SD)^2)} \quad (2b)$$

Where

GeoChl = Estimated geometric mean reference chlorophyll a defined during intercalibration

ArithChl = Arithmetic mean reference Chlorophyll defined during intercalibration

SD = standard deviation of log₁₀Chl samples for a "typical" lake

= 0.213 for low and moderate alkalinity lakes (estimated from large EU data set)

= 0.285 for high alkalinity lakes (estimated from large EU data set)

Calculation of EQR and boundary setting

The approach to boundary setting is documented in the Phase 1 intercalibration reports, and the chlorophyll a EQR boundaries used here are those determined in that exercise (Table 1, and Poikane 2008). In the case of low alkalinity lakes (alkalinity < 0.2 mEq/l) the

⁸ For a log normal distribution the arithmetic and geometric means are related by AM = GM x exp(0.5SD²)

original chlorophyll a EQR boundaries were adjusted during harmonisation, and then normalised using piecewise linear transformation (equation 3)

$$ChlEQR_{Norm} = \left[\left(\frac{EQR_{Chl} - LowerBoundary}{ClassWidth} \right) \times 0.2 \right] + LowerBoundary_{Norm} \quad (3)$$

Where

$ChlEQR_{Norm}$ = Normalised EQR (e.g. HG = 0.80, GM = 0.60, MP = 0.40, PB = - 0.20)

$LowerBoundary$ = lower un-normalised EQR boundary (see Table A.30)

$LowerBoundary_{Norm}$ = lower normalised EQR boundary of class (e.g for Good = 0.60)

$UpperBoundary_{Norm}$ = upper normalised EQR boundary of class (e.g. for Good = 0.80)

$ClassWidth$ = Class width of non-normalised scale (e.g for Good=0.55–0.32=0.23)

Table A.30 Chlorophyll a EQR boundaries for UK phytoplankton method

Lake Type	UK Type	IC Type (GIG)	Alkalinity (mEq/l)	Mean depth (m)	HG EQR	GM EQR	MP EQR	PB EQR
High alkalinity shallow	HAS	L-CB1	>1.0	3.0 - 15.0	0.55	0.32	0.16	0.05
High alkalinity very shallow	HAVS	L-CB2	>1.0	< 3.0	0.63	0.30	0.15	0.05
Moderate alkalinity deep	MAD		0.2 - 1.0	>15.0	0.50	0.33	0.17	0.05
Moderate alkalinity shallow	MAS	L-N1, L-N8a	0.2 - 1.0	3.0 - 15.0	0.50	0.33	0.17	0.05
Moderate alkalinity very shallow	MAVS		0.2 - 1.0	< 3.0	0.63	0.30	0.15	0.05
Low alkalinity deep	LAD	L-N2b	<0.2	>15.0	0.64	0.33	0.17	0.05
Low alkalinity shallow	LAS	L-N2a L-N3a	<0.2	3.0 - 15.0	0.64	0.29	0.15	0.05
Low alkalinity very shallow	LAVS		<0.2	< 3.0	0.63	0.30	0.15	0.05
Marl shallow	MarlS		>1.0	3.0 - 15.0	0.55	0.32	0.16	0.05
Marl very shallow	MarlVS		>1.0	< 3.0	0.63	0.30	0.15	0.05

Taxonomic Metric – Plankton Trophic Index (PTI)

The Phytoplankton Trophic Index (PTI) was derived from a CCA ordination (univariate analysis) of the taxonomic data constrained by total phosphorus (log transformed). This single variable was most significantly related to the 1st axis of all the constrained ordinations tested and reflects the main pressure of concern in lake management, eutrophication. CCA reduces to a weighted average ordination in the case of a single variable (Braak and Looman 1986), and species axis 1 scores represent the log₁₀ weighted average of total phosphorus. These scores were transformed to values between 0 (low pressure) and 1 (high pressure) by converting all the scores to positive values (by adding the lowest score), then dividing by the resulting maximum score.

The site PTI is calculated for each sample collected between July to September using equation 5; the resulting metric has a good relationship with phosphorus and chlorophyll a (Figure A.16).

$$PTI = \frac{\sum_{j=1}^n \log(a_j) s_j}{\sum_{j=1}^n \log(a_j)} \quad (5)$$

Where:

a_j = biovolume of j th taxon in the sample ($\mu\text{m}^3 \text{ ml}^{-1}$)⁹

s_j = optimum of j th taxon in the sample (see table A1)

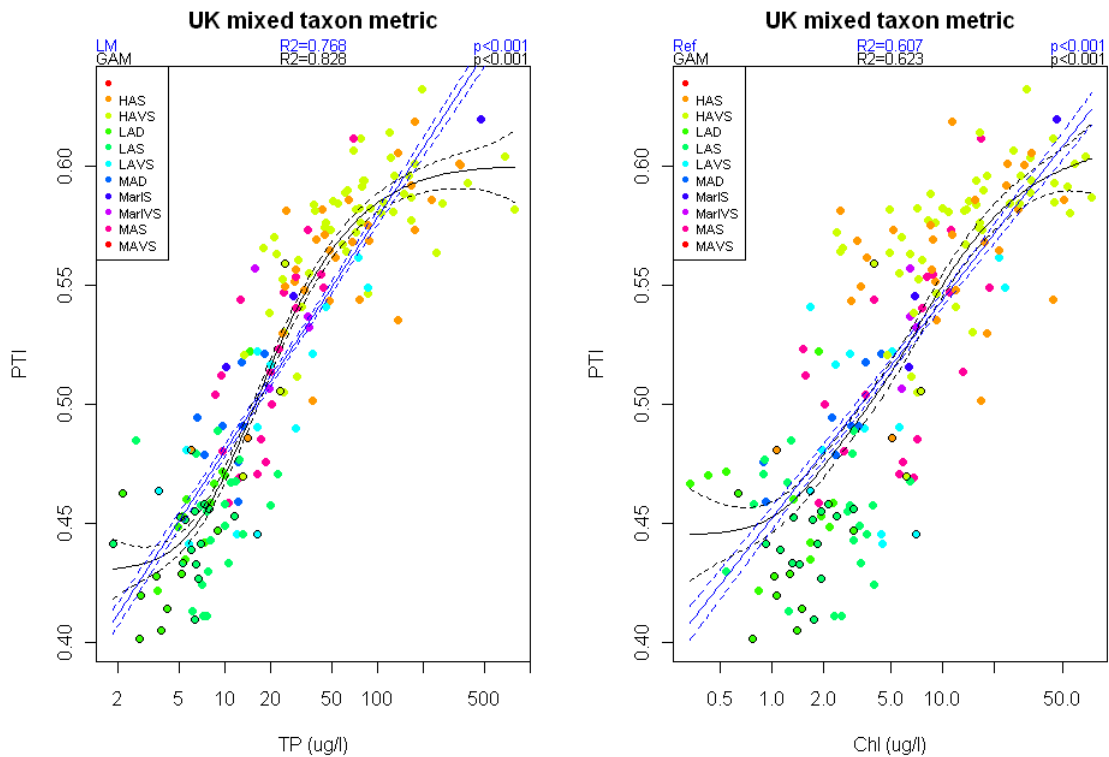

Figure A.16 Relationship between PTI metric and a) mean annual total phosphorus, b) mean annual chlorophyll a for UK lakes classified by waterbody type. Circles identify reference lakes

Correction of UK PTI during Intercalibration

The PTI metric calculated for UK sites in the intercalibration (WISER) database were notably different from those calculated for the same sites in the UK database due to the

⁹ The units are important due to the log transformation

compromises in taxonomic nomenclature that were made for international harmonisation of the common (WISER) database. To compensate for this, NGIG¹⁰ adjusted the PTI values calculated from the WISER intercalibration data set using the relationship between the scores calculated in the UK and those in the WISER database ($PTI_{UK} = 0.889 PTI_{WISER} + 0.0589$ $R^2 = 0.977$ $p < 0.001$).

Reference PTI

The reference PTI is predicted from a multiple regression model derived from a sub-set (26) of reference lakes where taxonomic data were available at the time of method development (equation 5).

$$\text{Reference PTI Model } PTI_{Ref} = 0.028 \times \log_{10}MEI + 0.498 \quad R^2 = 0.688 \quad (5)$$

Where

MEI = Alk/Depth (Morpho Edaphic Index)

Calculation of EQR_{PTI}

Site specific reference PTI values are calculated for each lake, and then are used to convert the observed sample PTI to an EQR using equation 6

$$EQR_{PTI} = \left(\frac{PTI_{Obs} - PTI_{Max}}{PTI_{Ref} - PTI_{Max}} \right) \quad (6)$$

Where:

PTI_{Obs} = Sample PTI

PTI_{Max} = Maximum PTI score (0.75)

PTI_{Ref} = Reference PTI

Sample EQR_{PTI} are then averaged to obtain a water body EQR_{PTI}

Boundary setting for EQR_{PTI}

EQR boundaries were initially set independently of the lake typology as the reference PTI are site specific and take into account alkalinity and depth (the key variables that have been found to determine the phytoplankton community; Phillips *et al.* 2010). The boundaries were subsequently reviewed in the light of type specific pressure responses and were also adjusted during the intercalibration process to ensure they were consistent with other European countries.

The High/Good EQR boundary was based on the 10th percentile of EQR_{PTI} values for reference lakes (H/G $EQR_{PTI} = 0.93$). The other EQR boundaries were set using changes in the proportion of taxa sensitivity groups, split according to their nutrient optima and with

¹⁰ For CBGIG lakes UK EQR values were taken directly from the UK dataset and not from the WISER database.

reference to the bio-volume of eutrophic cyanobacteria taxa. The fractions of very sensitive and very tolerant taxa and the relationships between EQR_{PTI} and eutrophic cyanobacteria were examined and potential boundaries identified using GAM and quantile regression models. The Good/Moderate boundary was initially set at 0.82, the point at which 50% of lakes still have 20% of the very sensitive taxa and 90% of lakes have less than 10% of the very tolerant taxa. Cyanobacteria first show an increase in biomass at an EQR_{PTI} of 0.85 (Figure A.17), a value that is below the proposed High/Good boundary and slightly above the proposed Good/Moderate boundary. At this point the response mainly occurs in high alkalinity lakes and although it represents more than a “slight” change in the phytoplankton community, it is clearly not a significant undesirable impact at this level. It is therefore consistent with good status, although the change in cyanobacterial response and the associated EQR_{PTI} value indicate that conditions are indeed approaching the Good/Moderate boundary. The Moderate/Poor boundary was initially set at 0.70, the point at which 50% of lakes have more than 5% of very tolerant taxa. The Poor/Bad boundary was set at 0.58, a value which provides the same class width for Poor as for Moderate (see Figure A.18 for all modelled boundaries).

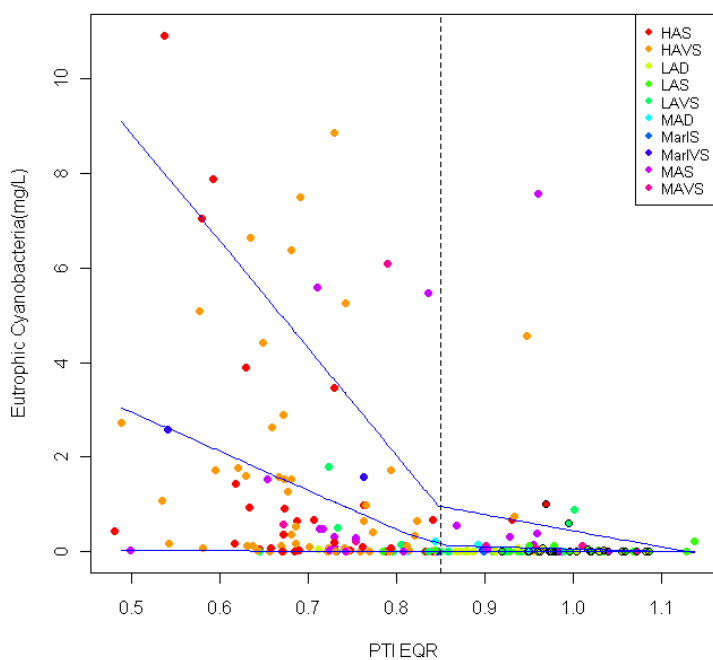

Figure A.17 *The relationship of EQR_{PTI} with the biovolume of eutrophic cyanobacteria. The 90th and 75th quantiles are given, reference sites are outlined and the potential EQR G/M boundary is shown at 0.85.*

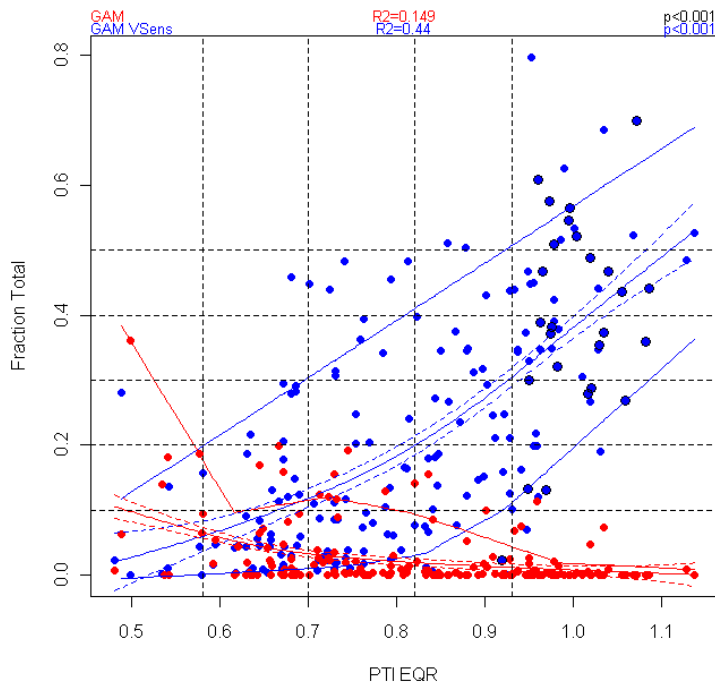

Figure A.18 The relationship between EQR_{PTI} and the fraction of very sensitive taxa (blue spots) and very tolerant (red spots) together with 90th and 10th quantile regressions and GAM models. Reference sites are outlined and the potential boundaries at EQR_{PTI} 0.93, 0.82, 0.70 and 0.58 are shown.

Although it was initially intended to apply these EQR boundaries to all lake types, it was observed that the EQR from lakes of different alkalinity types had significantly different relationships with pressure despite the use of a site specific model to determine reference conditions. The importance of alkalinity on the phytoplankton community has also been identified in larger European data sets (Phillips *et al.* 2010). These different relationships were quantified using linear mixed models (Figure A.19) with EQR_{PTI} as dependent variable, log TP as co-variable and type as a random variable. The model revealed significant differences in intercept between types, but not in slope. The model was repeated using fixed slopes and the resulting random effect values due to lake type (i.e. the differences in intercepts) were used to adjust the proposed EQR boundaries (Table A.31).

Table A.31 Random effect of lake geology type on relationship between PTI EQR and logTP for UK lakes, and the type specific EQR adjustments to account for this effect.

Lake Geology Type	Random effect of type on intercept of linear model	EQR adjustment
High Alkalinity	-0.021	-0.02
Moderate Alkalinity	-0.004	0.00
Low Alkalinity	+0.022	+0.02
Marl	+0.003	0.00

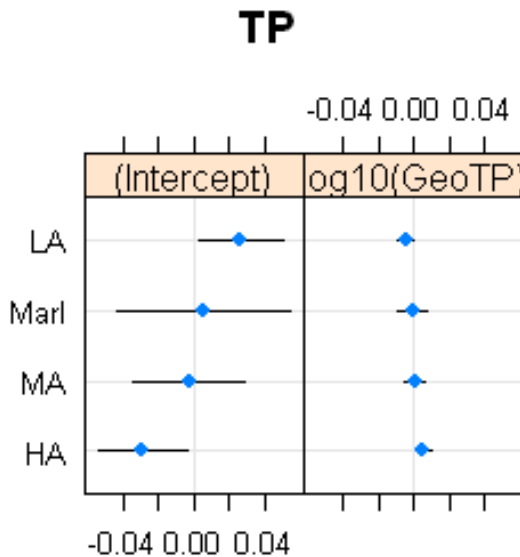

Figure A.19 The range of intercept and slope values for linear mixed models between PTI EQR and logTP. Horizontal lines show confidence limits.

During the intercalibration process these boundaries were adjusted to ensure that the UK method was not less precautionary than other member states with similar lake types. Boundaries for other UK lake types that could not be intercalibrated were adjusted based on those that were. Very shallow lakes were assumed to have less stringent boundaries than shallow lakes and low alkalinity lakes humic lakes to have less stringent boundaries than low alkalinity clear water lakes. The original and final harmonised EQR_{PTI} boundaries are shown in Table A.32.

The EQR_{PTI} is normalised using quadratic functions of the form

$$PTIEQR_{Norm} = A \times EQR_{PTI}^2 - B \times EQR_{PTI} - C$$

Parameters used for each lake type are also given in Table A.32

Bloom Frequency Metric – Cyanobacteria bio-volume

The WFD requires that the assessment of lake phytoplankton should include an assessment of the frequency and intensity of algal blooms. It does not define an algal bloom, but a definition emerging from the intercalibration process is that it refers to an elevated biomass of cyanobacteria. Cyanobacteria are associated with enriched conditions in lakes and can produce a high biomass of potentially toxic algae which can restrict the use of a lake. This is a clear case of “undesirable disturbance” as defined by the WFD (European Commission 2009). Although increases in cyanobacteria are indicated by both an elevated biomass (chlorophyll concentration) and an increase in the

PTI, the UK method now includes a direct assessment of cyanobacterial biomass using the median biovolume of cyanobacteria.

Boundary Setting for Cyanobacteria biomass

The cyanobacteria metric assesses “undesirable disturbance” by indicating the risk of cyanobacterial blooms occurring, using the low and medium risk thresholds defined as by the World Health Organisation as 20,000 and 100,000 cells ml⁻¹ respectively (Who 1999). These values were converted to bio-volume thresholds of 1 and 5 mm³ l⁻¹ by multiplication of a typical cell volume (based on a spherical cell such as *Microcystis* with a cell diameter of 4.5µm; Hillebrand *et al.* 1999).

Status boundaries were set in accordance with the Eutrophication Guidance (European Commission 2009). This document proposes an increasing risk of undesirable disturbances, thus at Good status there should be a very low probability of blooms occurring. The likelihood increases through the Moderate class and is high at Poor status. The distribution of cyanobacteria biomass in summer samples can be used to assess how often a particular lake exceeds these thresholds and consequently a classification can be derived. It is proposed that at the High/Good boundary 90% of samples would be below the 1 mm³ l⁻¹ threshold, and at the Good/Moderate 25% of samples would be below this threshold. The Moderate/Poor boundary was set where 75% of samples were above the 1 mm³ l⁻¹ threshold but below 5 mm³ l⁻¹, and the Poor/Bad boundary where 75% of samples exceeded the 5 mm³ l⁻¹ threshold (Figure A.20).

The European (WISER database) lakes were classified according to the distribution of cyanobacteria using the above rules. The median summer cyanobacteria bio-volume (July – September) was calculated for each lake. The distribution of these median values in each class was determined and boundary values for were set at the overlap between the upper and lower 25th percentiles of adjacent classes (Figure A.21 and Table A.33). The High/Good boundary median cyanobacteria biovolume is well below the WHO “vigilance” level (0.2 mm³ l⁻¹), and the Good/Moderate boundary is below the low risk threshold and is therefore consistent with a low risks of “undesirable disturbance”.

Intercalibration of biological elements for lake water bodies

Table A.32 EQR boundaries for Plankton Trophic Index (PTI). The harmonised boundaries are the final values used in the UK method following intercalibration. Equations for normalisation are also shown.

Lake Type	Humic Type	UK Type	IC Type (GIG)	Type Parameter values			Original Boundaries				Harmonised Boundaries				Normalisation equation			
				Alkalinity mEq/l	Mean depth m	Colour mgPt/l	HG EQR	GM EQR	MP EQR	PB EQR	HG EQR	GM EQR	MP EQR	PB EQR				
High alkalinity shallow		HAS	L-CB1	>1.0	3.0 - 15.0	not used	0.91	0.80	0.68	0.56	0.93	0.82	0.70	0.58	$EQR_{Norm} = 1.228 \times EQR^2 - 0.0898 \times EQR - 0.1538$			
High alkalinity very shallow		HAVS	L-CB2	>1.0	< 3.0						0.91	0.80	0.68	0.56	$EQR_{Norm} = 1.228 \times EQR^2 - 0.0407 \times EQR - 0.1551$			
Moderate alkalinity deep		MAD		0.2 - 1.0	>15.0		0.93	0.82	0.70	0.58	0.95	0.84	0.72	0.60	$EQR_{Norm} = 1.228 \times EQR^2 - 0.1389 \times EQR - 0.1515$			
Moderate alkalinity shallow		MAS	L-N1, L-N8a	0.2 - 1.0	3.0 - 15.0						0.93	0.82	0.70	0.58	$EQR_{Norm} = 1.228 \times EQR^2 - 0.1389 \times EQR - 0.1515$			
Moderate alkalinity very shallow		MAVS		0.2 - 1.0	< 3.0						0.93	0.82	0.70	0.58	$EQR_{Norm} = 1.228 \times EQR^2 - 0.0898 \times EQR - 0.1538$			
Low alkalinity deep	Clear	LADcl	L-N2b	<0.2	>15.0	0.95	0.84	0.72	0.60	0.98	0.87	0.75	0.63	$EQR_{Norm} = 1.228 \times EQR^2 - 0.2004 \times EQR - 0.147$				
Low alkalinity deep humic	Humic	LADhm		<0.2	>15.0					0.95	0.84	0.72	0.60	$EQR_{Norm} = 1.228 \times EQR^2 - 0.1389 \times EQR - 0.1515$				
Low alkalinity shallow	Clear	LAScl	L-N2a	<0.2	3.0 - 15.0					0.98	0.87	0.75	0.63	$EQR_{Norm} = 1.228 \times EQR^2 - 0.2004 \times EQR - 0.147$				
Low alkalinity shallow humic	Humic	LAShm	L-N3a	<0.2	3.0 - 15.0					0.96	0.85	0.73	0.61	$EQR_{Norm} = 1.228 \times EQR^2 - 0.1512 \times EQR - 0.1508$				
Low alkalinity very shallow	Clear	LAVScl		<0.2	< 3.0					0.95	0.84	0.72	0.60	$EQR_{Norm} = 1.228 \times EQR^2 - 0.1389 \times EQR - 0.1515$				
Low alkalinity very shallow humic	Humic	LAVShm		<0.2	< 3.0					0.93	0.82	0.70	0.58	$EQR_{Norm} = 1.228 \times EQR^2 - 0.0898 \times EQR - 0.1538$				
Marl shallow		MarlS		>1.0	3.0 - 15.0					0.93	0.82	0.70	0.58	0.95	0.84	0.72	0.60	$EQR_{Norm} = 1.228 \times EQR^2 - 0.1389 \times EQR - 0.1515$
Marl very shallow		MarlVS		>1.0	< 3.0					0.93	0.82	0.70	0.58	0.93	0.82	0.70	0.58	$EQR_{Norm} = 1.228 \times EQR^2 - 0.0898 \times EQR - 0.1538$

Table A.33 Boundary values and EQRs for summer cyanobacteria biomass

Boundary	Cyanobacteria bio-volume (July - September) samples	Median cyanobacteria bio-volume ($mm^3 l^{-1}$)		EQR boundary values	
		Low & Moderate Alkalinity & Marl lakes	High alkalinity lakes	Low & Moderate Alkalinity & Marl lakes	High alkalinity lakes
Reference		0	0.01	1.00	1.00
High/Good	90th percentile $< 1 mm^3 l^{-1}$	0.08	0.20	0.47	0.63
Good/Moderate	75th percentile $< 1 mm^3 l^{-1}$	0.56	1.00	0.32	0.43
Moderate/Poor	25th percentile $< 1 mm^3 l^{-1}$	1.58	2.00	0.23	0.34
Poor/Bad	10th percentile $< 1 mm^3 l^{-1}$	5.62	5.62	0.13	0.21

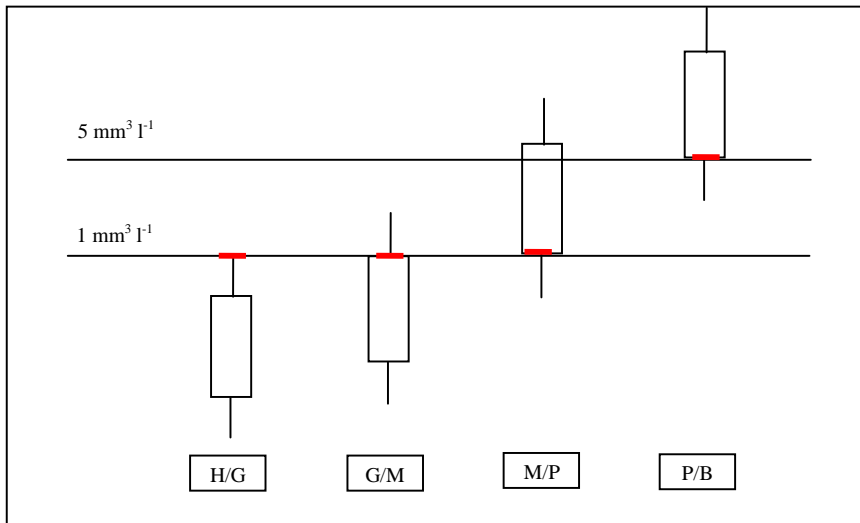

Figure A.20 Diagram illustrating position of WFD boundaries using different percentiles of cyanobacteria bio-volume. Boxes represent 25th, 75th percentiles, tails 90th percentiles, horizontal line represent the biomass equivalent to the low and medium risk WHO thresholds for blooms. Red lines identify the tested percentile to determine class

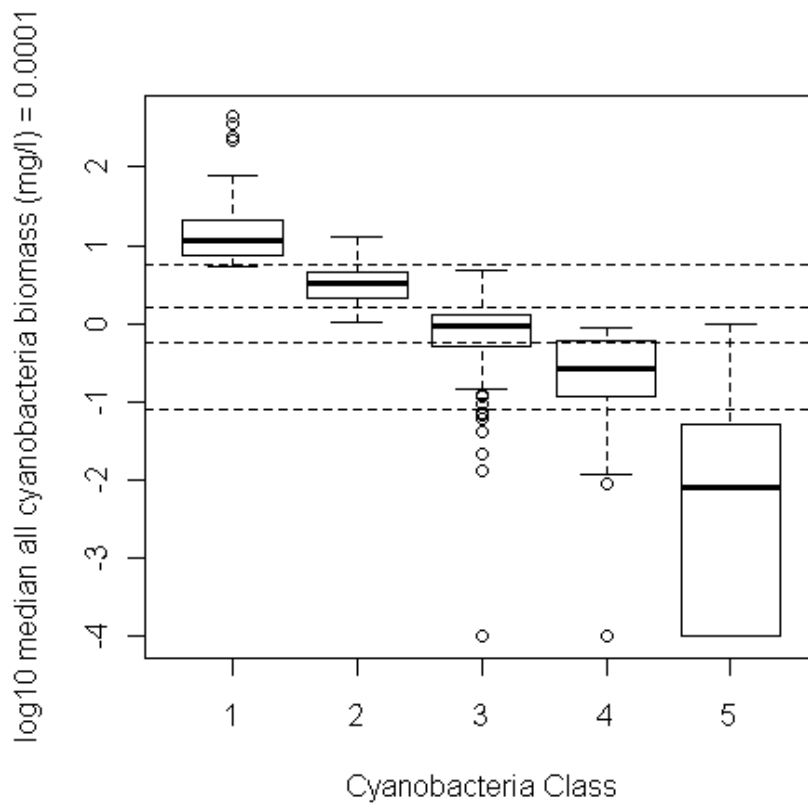

Figure A.21 Distribution of median biomass of cyanobacteria in European lakes in different WFD classes (5 high, 4 good, 3 moderate, 2 poor, 1 bad). Boxes

represent upper and lower 25th percentiles, lines 90th percentiles. Horizontal dotted lines mark boundary values for median summer cyanobacteria.

Conversion to EQR

The median cyanobacteria bio-volumes were converted to EQRs using the following equation¹¹.

$$EQR_{Cyan} = \frac{\log(BV_{Obs} + 0.0001) - \log(BV_{Max} + 0.0001)}{\log(BV_{Ref} + 0.0001) - \log(BV_{Max} + 0.0001)} \quad (7)$$

Where

BV_{Obs} = median bio-volume cyanobacteria ($\text{mm}^3 \text{ l}^{-1}$)¹²

BV_{Ref} = median bio-volume cyanobacteria in reference lakes ($\text{mm}^3 \text{ l}^{-1}$)
 = 0.01 $\text{mm}^3 \text{ l}^{-1}$ for high alkalinity lakes
 = 0.00 $\text{mm}^3 \text{ l}^{-1}$ for other lake types

BV_{Max} = maximum median bio-volume (taken as 30.0 $\text{mm}^3 \text{ l}^{-1}$)

If $BV_{Obs} > BV_{Max}$ then EQR_{Cyan} defaults to 0.0

The EQR_{Cyan} is then normalised using equation 8 for combination with other metrics

$$CyanEQR_{Norm} = \left[\left(\frac{EQR_{Cyan} - LowerBoundary_{Norm}}{ClassWidth} \right) \times 0.2 \right] + LowerBoundary_{Norm} \quad (8)$$

For derivation of terms see equation 3

Combination of metrics

To calculate an overall EQR, the normalised metric EQRs are combined by averaging.

The $ChlEQR_{Norm}$ and the $PTIEQR_{Norm}$ are first averaged to produce an interim EQR ($IntEQR_{Norm}$).

The cyanobacteria metric is only included in order to downgrade a lake status where blooms are likely; the absence of cyanobacteria should not upgrade the status of a lake. Consequently, if the $CyanEQR_{Norm}$ is $< IntEQR_{Norm}$ it is averaged with $IntEQR_{Norm}$, otherwise the cyanobacteria metric is ignored.

The resulting overall EQR represent status on a standard scale with boundaries of HG=0.80, GM=0.60, MP=0.40 and PB=0.20

Data checking and uncertainty estimation

¹¹ Logarithms are used to create a realistic class width on the EQR scale

¹² To convert from $\mu\text{m}^3 \text{ ml}^{-1}$ to $\text{mm}^3 \text{ l}^{-1}$ divide by 10^6

Classification is normally based on data collected over the preceding three years. The mean metric values (Chlorophyll a concentration, PTI and Cyanobacteria bio-volume) should be calculated for this period before calculating EQRs.

Samples for Chlorophyll a must be collected evenly throughout the year (i.e. at the same time each month). Twelve monthly samples should be used, but at minimum of 1 sample from each quarter of the year is required to calculate a representative mean.

Phytoplankton counts should be checked by comparing the calculated total sample bio-volume against a value predicted from the sample chlorophyll a value (equation 9). If the total sample bio-volume is outside of the predicted value $\pm 95^{\text{th}}$ percentile of the modelled residuals the sample should be marked as "suspect" and the results compared with other samples from the same lake and time of year, before these sample results for Cyanobacteria and PTI are used.

$$BV_{Pred} = 10^{1.18 \times \log(Chl) - 1.11}$$

$$UpperBV_{Pred} = 10^{1.18 \times \log(Chl) - 1.11 + 0.5} \quad (9)$$

$$LowerBV_{Pred} = 10^{1.18 \times \log(Chl) - 1.11 - 0.5}$$

The uncertainty of each metric will be estimated and combined to provide an overall assessment of confidence of class. The method for estimating uncertainty is currently under development.

References

- Braak, C. J. F. and C. W. N. Looman (1986). Weighted averaging, logistic regression and the gaussian response model. *Plant Ecology* **65**: 3-11.
- European Commission (2009). *Common implementation strategy for the water framework directive (2000/60/ec). Guidance document on eutrophication assessment in the context of European water policies*. Brussels, European Commission.
- Hillebrand, H., C.-D. Dürselen, D. Kirschtel, U. Pollinger and T. Zohary (1999). Biovolume calculation for pelagic and benthic microalgae. *Journal of Phycology* **35**: 403-424.
- Phillips, G., G. Morabito, L. Carvalho, A. Lyche-Solheim, B. Skjelbred, J. Moe, T. Andersen, U. Mischke, C. De Hoyos and G. Borics (2010). Deliverable d3.1-1: Report on lake phytoplankton composition metrics, including a common metric approach for use in intercalibration by all gigs.
- Poikane, S. (2010) *Water framework directive intercalibration technical report Part 2: lakes Luxembourg*, European Commission.
- Who (1999). *Toxic cyanobacteria in water: A guide to their public health consequences, monitoring and management*. London, E & F N Spon.

B. Evaluation of relationship between national methods and cyanobacteria biomass

B.1 Central/Baltic GIG data analysis

The WFD requires that for the assessment of phytoplankton consideration is given to the frequency of algal blooms. There is no clear definition of an algal bloom, either within the GIG or as a result of work carried out by WISER and this should be considered a significant shortcoming of the directive. An emerging definition of a “bloom” is that it represents an abnormal elevated biomass of cyanobacteria. Cyanobacteria are widely recognised as a potential problem in eutrophic lakes and it is necessary that the assessment methods used are able to detect an elevated biomass.

Analysis has been carried out by IE, DK and DE to demonstrate that the final EQR of their assessment methods are significantly related to cyanobacteria biomass. A similar analysis using the GIG data set for LCB1 and LCB2 lakes has been undertaken to confirm that all methods are able to detect an elevated biomass.

For each method, including the common metric, the final EQR was plotted against the log of cyanobacteria biomass + 0.1. The log transformation was necessary as many lakes have a zero biomass of cyanobacteria (Figure B.1). The GIG data set confirms that cyanobacteria biomass increases with total phosphorus (Figure B.1), but it should be noted that even at high total phosphorus very low cyanobacteria biomass can occur. All methods show significant positive relationships between the final EQR and cyanobacteria biomass (see Figure B.1 and Table B.1).

Therefore, the GIG thus concludes that all the methods are able to detect elevated biomass of cyanobacteria and thus are able to demonstrate that they can detect algal blooms.

Table B.1 Coefficient of determination for relationship between national final EQR and cyanobacteria biovolume

Country	LCB1 adj r ²	LCB2 adj r ²
Common Metric	0.415	0.317
UK	0.299	0.475
DE	0.541	0.622
EE	0.248	0.434
LV	0.339	0.370
BE	0.585	0.669
NL	0.290	0.271
LT	0.197	0.222
PL	0.653	0.702
IE	0.383	0.426
DK	0.527	0.584

Intercalibration of biological elements for lake water bodies

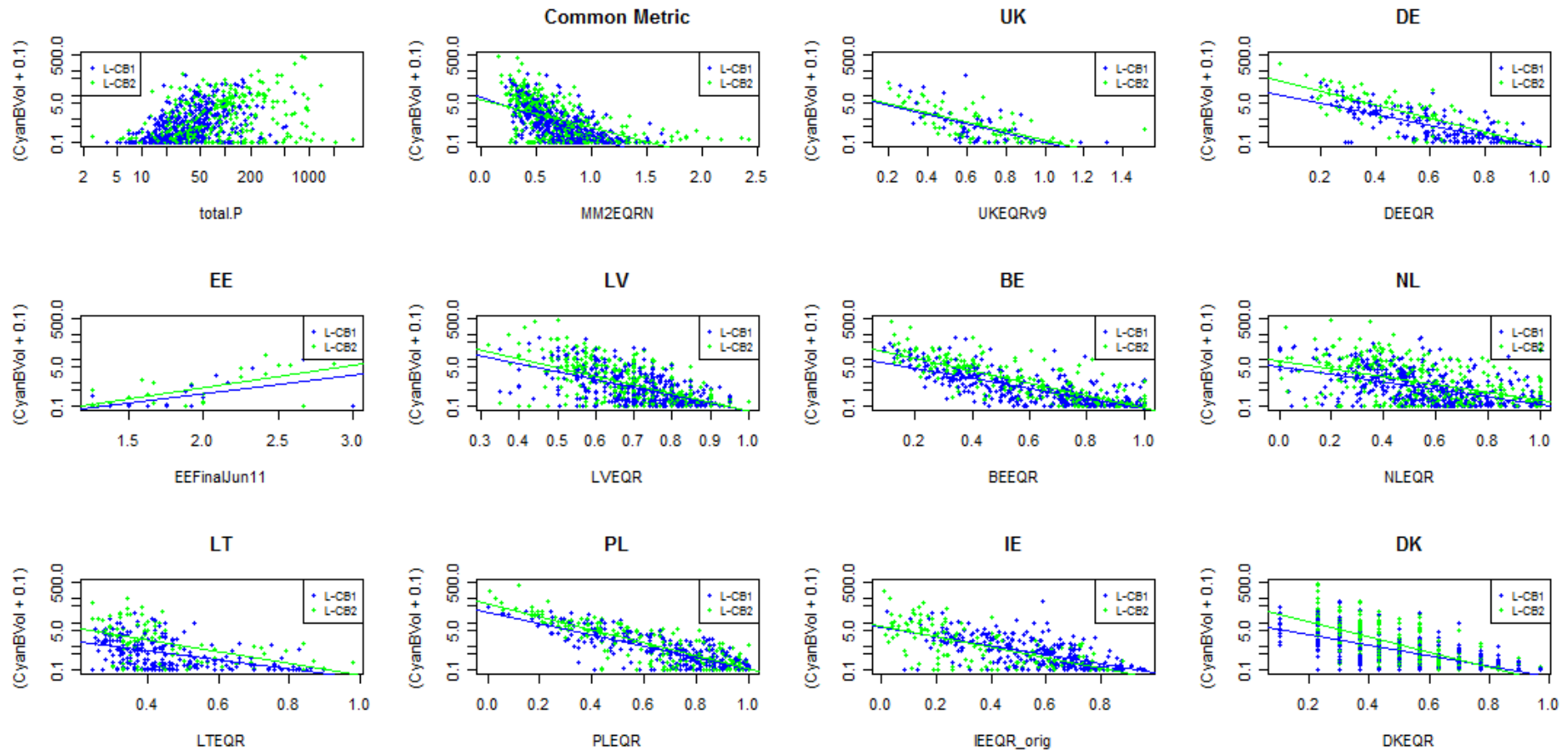

Figure B.1 Relationship between cyanobacteria biovolume and TP, and national final EQR and cyanobacteria biovolume for Central Baltic GIG lakes

B.2 The applicability of existing IE phytoplankton metrics in reflecting blooms

Introduction

During recent discussions at Northern and Central Baltic phytoplankton GIG meetings it became apparent that many MS did not have a specific bloom metric and ecological assessment was mainly carried out for the BQE using composition and biomass (chlorophyll *a*).

The metric used in Ireland uses chlorophyll *a* as an indicator of biomass. The composition metric uses a list of indicator taxa that includes Cyanobacteria and is scored based on abundance or biovolume. Further details are provided on the WISER website (<http://www.wiser.eu/>) and in Free et al. (2006). Both the biomass and composition parameters are normalised and then averaged to give an EQR.

In order to examine the potential for the existing IE metric to reflect the 'bloom' aspect of the BQE it was decided to follow two approaches:

- To carry out a correlation analysis between the national metric normalised EQR and the sum of Cyanobacteria biovolume;
- To carry out a multiple regression using TP as a dependent variable and the national EQR and Cyanobacteria biovolume as predictors. This should indicate whether Cyanobacteria are significant in explaining additional variation in the BQE along the pressure gradient.

The data from the Central Baltic GIG was used to carry out the analysis. The IE metric was calculated for 283 LCB1 lake years and for 148 LCB2 lake years.

Results and Discussion

The IE phytoplankton EQR was significantly ($p \leq 0.0001$) correlated with $\log(x+1)$ transformed sum of Cyanobacteria for both LCB1 ($r^2 = 0.29$) and 2 ($r^2 = 0.32$) (Figure B.2). The dataset contained many values close to zero for cyanophyte biovolume despite transformation. The non-parametric Spearman rank correlation coefficients for the relationship were -0.59 for LCB1 and -0.61 for LCB2 ($p < 0.0001$). Given the significant relationship between the IE metric and the sum of *Cyanobacteria*, the bloom aspect represented by *Cyanobacteria* is likely to be reflected to some degree in the existing IE metric.

Mischke et al. (2010) suggested a value of 10 mm³ ml⁻¹ of Cyanophyte biovolume, derived from the WHO levels for *Cyanobacteria* abundance, as a useful medium risk threshold. Using the data for both LCB1 and 2 the existing IE metric would classify 97.5% of lakes as being of moderate class or lower that had in excess of 10 mm³ ml⁻¹ of *Cyanobacteria* biovolume. This provides reasonably strong support that the existing IE metric already detects bloom events and correctly identifies the need for a programme of measures.

Stepwise multiple regression using TP as a dependent variable and the IE EQR and transformed (log x+1) Cyanobacteria biovolume as predictors was carried out for both LCB1 and LCB2. Cyanobacteria biovolume was not significant in explaining additional variation in the pressure gradient (TP) alongside the existing IE metric for both LCB1 ($p = 0.23$) and LCB2 ($p = 0.41$) (Table B.1, Table B.2). There are likely to be a couple of explanations for this, the first is that the existing IE metric already reflects Cyanobacteria biomass as indicated by the correlation analysis above and the second is that Cyanobacteria alone are unreliable as an indicator of pressure. Transformed (log x+1) Cyanobacteria had a low r^2 with Log TP for LCB1 (0.12, $p \leq 0.0001$) and LCB2 lakes (0.09, $p \leq 0.0001$).

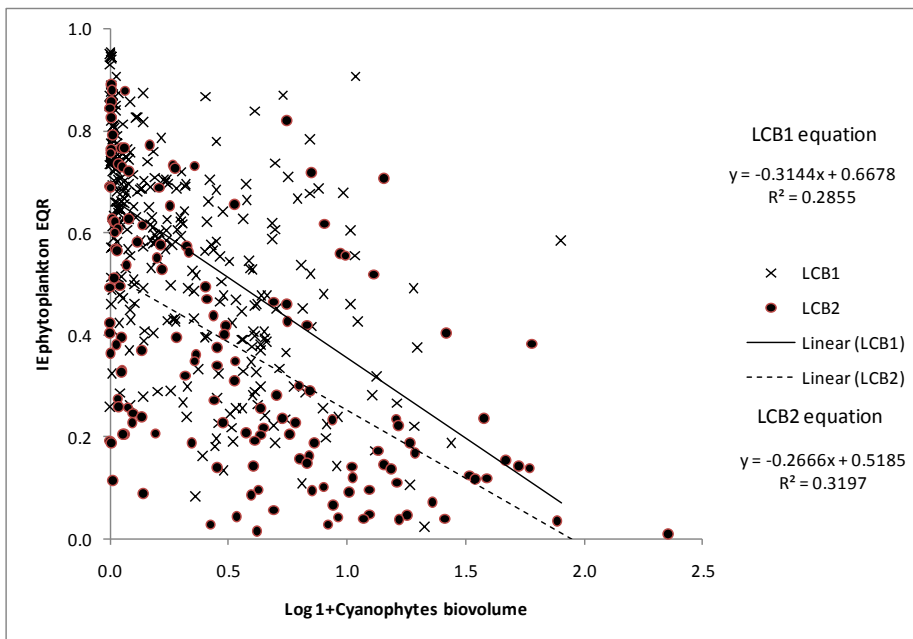

Figure B.2 Relationship between the Log x+1 transformed sum of cyanophytes and the IE phytoplankton metric for both LCB1 and LCB2.

In conclusion the existing IE metric is already correlated with the biovolume of Cyanobacteria and including an additional metric based on Cyanobacteria would not increase the ability to detect responses to pressure.

Table B.2 Multiple regression for log TP ($\mu\text{g l}^{-1}$) for LCB1 lakes. $n = 262$.

Step	Variable	r^2	Model
1	IE NEQR	0.40	$\text{Log TP} = 2.19949 - 1.09375 \cdot \text{IE NEQR}$
2	Log 1+cyanophyte biovolume	0.41	$\text{Log TP} = 2.13894 - 1.02903 \cdot \text{IE NEQR} + 0.0718895 \cdot \text{Log 1+cyanophyte biovolume}$

Table B.3 Multiple regression for log TP ($\mu\text{g l}^{-1}$) for LCB2 lakes. $n = 131$.

Step	Variable	r^2	Model
1	IE NEQR	0.34	$\text{Log TP} = 2.36318 - 1.1751 \cdot \text{IE NEQR}$

2	Log 1+cyanophyte biovolume	0.34	$\text{Log TP} = 2.43147 - 1.25786 \cdot \text{IE NEQR} - 0.0665084 \cdot \text{Log 1+cyanophyte biovolume}$
---	----------------------------	------	--

References

Free, G., Little, R., Tierney, D., Donnelly, K. & Caroni, R. (2006) A reference based typology and ecological assessment system for Irish lakes. Preliminary investigations., pp. 266. Wexford, Ireland. WWW.epa.ie

Mischke, U., Carvalho, L., McDonald, C., Skjelbred, B., Solheim, A.L., Phillips, G., de Hoyos, C., Borics, G. & Moe, J. (2010) Deliverable D3.1-2: Report on phytoplankton bloom metrics. IGB, Berlin.

B.3 The use of cyanobacteria in the ecological classification of lakes in Denmark

This note is based on a recent paper by Søndergaard et al. (2011) and gives a short summary on the potentials of using cyanobacteria in the ecological classification of lakes. Planktonic blooms and their frequency and intensity are specifically mentioned in the Water Framework Directive as part of the ecological classification of lakes. Excessive growth of particularly toxic cyanobacteria is often seen as one of the main negative effects of eutrophication, and these blooms create huge environmental and human health problems throughout the world.

The analysis is based on a study of 440 Danish lakes sampled during the past 20 years. The lakes were divided into three types based on mean depth (z) and total alkalinity (TA) using the definitions of the Central-Baltic intercalibration group: 1) stratified, calcareous lakes (z: 3-15 m, TA>1 meq/l, number of lakes, n= 64-76), 2) shallow, calcareous (z: < 3 m, TA > 1 meq/l, n = 126-167), and 3) siliceous lakes (TA< 1 meq/l, n=64-70). Some of the lakes have been sampled for more than one year and the total number of lake-years in each lake type varies from 270 to 619. Most lakes were shallow with high total phosphorus (TP) and chlorophyll a (Chla) concentrations. All lakes are situated at an altitude below 150 m a.s.l. and only freshwater lakes with area > 1 hectare and colour < 60 mg Pt/l were included. The analyses were restricted to lakes with TP < 0.5 mg P/l and Chla < 300 µg/l to concentrate on levels most relevant for the classification of lakes. The proportion of cyanobacteria (%CYANO) was calculated as $100 \cdot \frac{\text{cyanobacteria biovolume}}{\text{total phytoplankton biovolume}}$ (as summer or monthly means).

Results

In the whole data set %CYANO was significantly and positively related to both TP and TN for all lakes and the three lake types, but the correlation was weak and the correlation coefficient ranges from 0.06 to 0.09 for TP and from 0.04 to 0.08 for TN. A multiple regression using both TP and TN only increased the correlation slightly, increasing the coefficient by between 0.06-0.11. The relationship between %CYANO and TP or Chla is without clear thresholds (Figure B.3). The variability within the different Chla and TP levels

is high and there is often a factor 5-10 between the 25% quartile and the 75% quartile at a given Chla or TP level.

In five case study lakes %CYANO is always low in the two most nutrient-poor lakes (Lake Sjøby and Lake Holm) and below 4% in all years except one, whereas summer mean %CYANO is higher, but highly variable in the two most nutrient rich lakes, ranging from 5 to 74% in Lake Bryrup Langsø and from 2 to 94% in Lake Tissø (Figure B.4). Lake Nors, which is also relatively nutrient-poor, has high %CYANO during the first sampling years, but has been relatively stable around 20% during the past 10 years. Seasonally, %CYANO reaches its maximum between August and October, but the maximum levels differ considerably over the 20-year period (Lake Nors: 11-98%, Lake Sjøby: 0-23%, Lake Holm: 0-100%, Lake Bryrup Langsø: 31-100% and Lake Tissø: 6-99%).

Conclusions

The proportion of cyanobacteria increased significantly with TP and Chlorophyll a, but the correlation was weak, particularly for shallow and siliceous lakes. Seasonal and yearly data from five lakes with relatively stable TP show considerable variations in cyanobacteria abundance during a 20-year monitoring period. It seems likely that the proportion of cyanobacteria might be more difficult to use as a metric to evaluate anthropogenic influence on lake water quality than Chla. One of the reasons might be that cyanobacterial blooms are highly influenced by a number of additional factors, such as temperature, water column stability and carbon availability or sometimes driven by top-down rather than bottom-up effects. It is concluded that despite clear nutrient phytoplankton relationships it will be difficult to define the proposed WFD ecological classes - particularly regarding the use of cyanobacteria.

Intercalibration of biological elements for lake water bodies

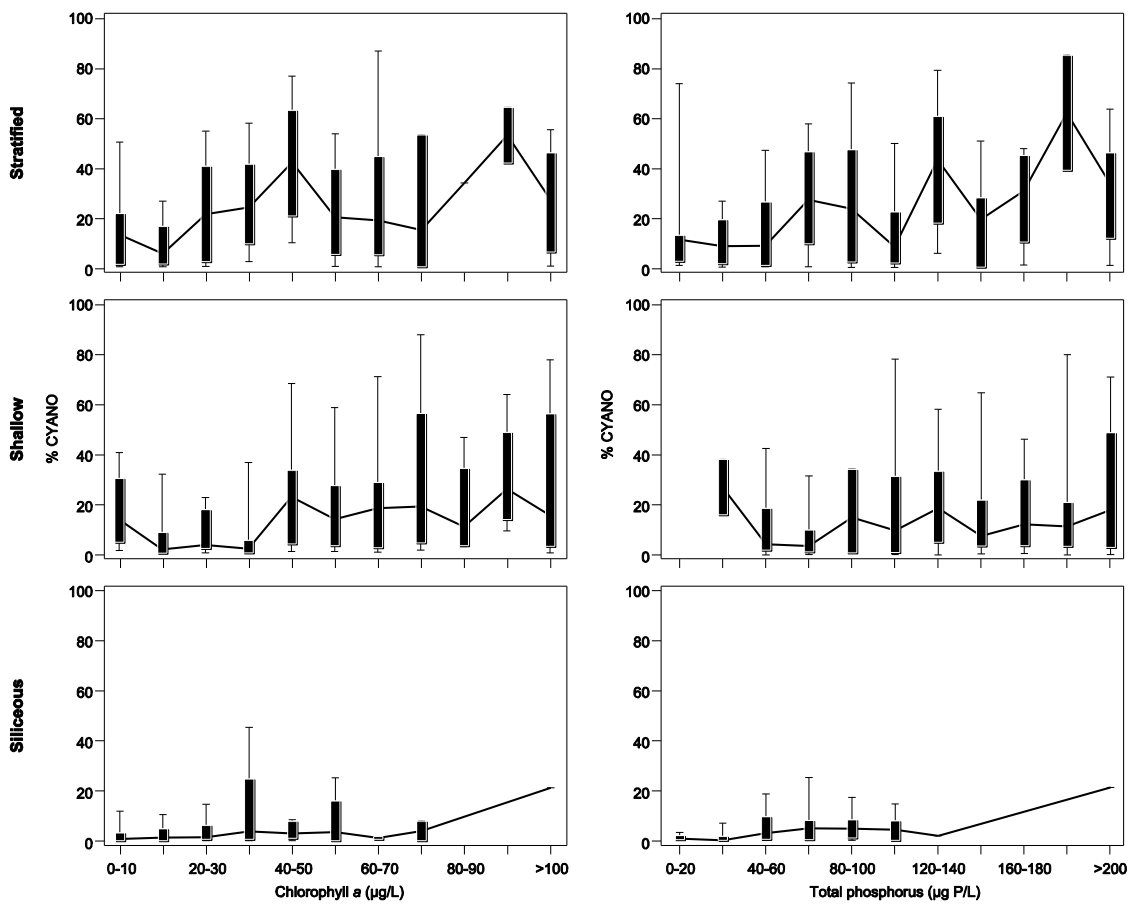

Figure B.3 Box-plots of proportion of cyanobacteria to total phytoplankton biovolume (%CYANO) along a Chla and TP gradient (summer averages). Each box shows 10%, 25%, median (connected), 75% and 90% fractiles. Number of lake-years = 213, 283 and 83 in stratified, shallow and siliceous lakes, respectively. From Søndergaard et al. (2011).

Intercalibration of biological elements for lake water bodies

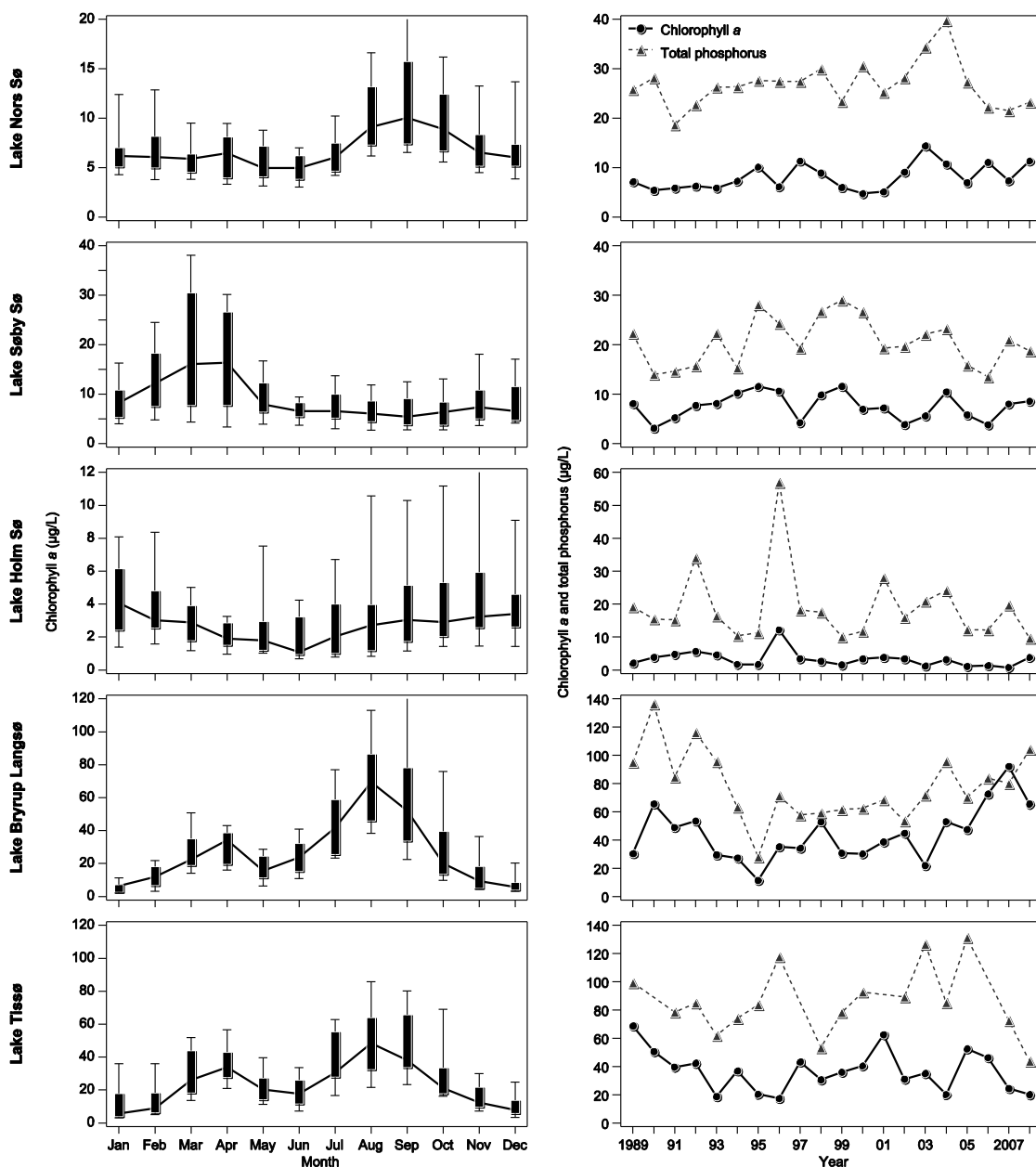

Figure B.4 Chla in five case study lakes. Left column shows seasonal variation in Chla based on 20 years monthly measurements and the right column annual variations (summer average). The right column also depicts average summer phosphorus concentrations. Boxes in the seasonal variation show 10% (lower line), 25%, median (connected), 75% and 90%(upper line) fractiles.. From Søndergaard et al. (2011).

References

Søndergaard, M , Larsen, SE, Jorgensen, TB, Jeppesen, E 2011. Using chlorophyll a and cyanobacteria in the ecological classification of lakes. *Ecological Indicators* 11: 1403-1412.

B.4 Response of the German Phyto-See-Index to increasing biomass of Cyanobacteria in lowland lakes.

Introduction

All relevant parameters indicative of the biological quality element phytoplankton must be covered (see Table 1 in the IC Guidance). The JRC recommend that the bloom metric is missing in most national methods and the suggested WISER metric should be applied.

In the German method, called Phyto-See-Index (Mischke et al. 2008), a distinct metric on algal bloom is missing.

Still, the German method includes several parameters to assess Cyanobacteria and other algal blooms:

1. In the biomass metric an assessment of the parameters mean chlorophyll, mean total biovolume and maximum chlorophyll a concentration are merged
2. Biovolume of Cyanobacteria and other algal classes are assessed within the algal class metric
3. Biovolume of Cyanobacteria indicator taxa are assessed in the PTSI (taxonomic optima of taxa associated with bloom forming species have always high values)

The CB GIG phytoplankton expert group concluded in the Milestone 5 report, that all countries have methods that will detect elevated biomass of cyanobacteria.

Still, there is no clear agreement regarding the definition of a bloom, either within the GIG and this is a significant short-coming of the directive. An emerging definition of a bloom is that this is an elevated biomass of cyanobacteria.

Here it is demonstrated that the German assessment system already is sensitive to response on algal blooms, especially on high Cyanobacteria biomass.

Secondly, the metric Cyano-biovolume is applied on the CB-GIG data and analysed in response to the main pressure "eutrophication" represented the parameter total phosphorus concentrations.

Data used

Data were taken from the CB-GIG data base shared with WISER-project data and also used for intercalibration (see file German_PSI_response_to_cyano_pressure.xls). The data comprised lake data from all CB-GIG countries.

There were 226 years of L-CB 1 years and 114 years of L-CB 1 available for analysis.

Pressure: Summer mean abundance of Cyanobacteria using data spanning the months July, August and September (like WISER metric) is used.

Response indicator: German Phyto-See-Index according Mischke et al. (2008), whole method result. The PSI operates between in the range of 0.5 (highest) to 5.5 (most bad).

Results

The German PSI is clearly sensitive to high biovolume of Cyanobacteria (>5 mm³/L) and indicate those lakes at least in the moderate and mainly in the poor status (poor = 3.5 – 4.5).

In the very shallow lakes (Figure B.6) the German PSI is more sensitive to Cyanobacteria than in the shallow lakes (L-CB 1, see Figure B.5). This fact is driven by more frequent and stronger Cyanobacteria blooms (>10 mm³/L) in the very shallow lakes.

- a. Correlation of German PSI versus summer mean of Cyanobacteria biovolume:

L-CB 1 $r^2 = 0.442$ (N = 226)

L-CB 2 $r^2 = 0.599$ (N = 114)

If there is no Cyanobacteria bloom, algal blooms by other algal blooms are possible and they are already reflected by the chlorophyll a concentration, which is an accepted surrogate for algal biomass. The German Phyto-See-Index responses very tight to increasing biomasses.

- b. Correlation between German PSI to seasonal mean of chlorophyll a

L-CB 1 $r^2 = 0.694$ (N = 218)

L-CB 2 $r^2 = 0.718$ (N = 105)

In Figure B.7, the high uncertainty of the metric based on the biovolume of the Cyanobacteria proposed in the EU Project WISER is demonstrated when total phosphorus is used as the pressure.

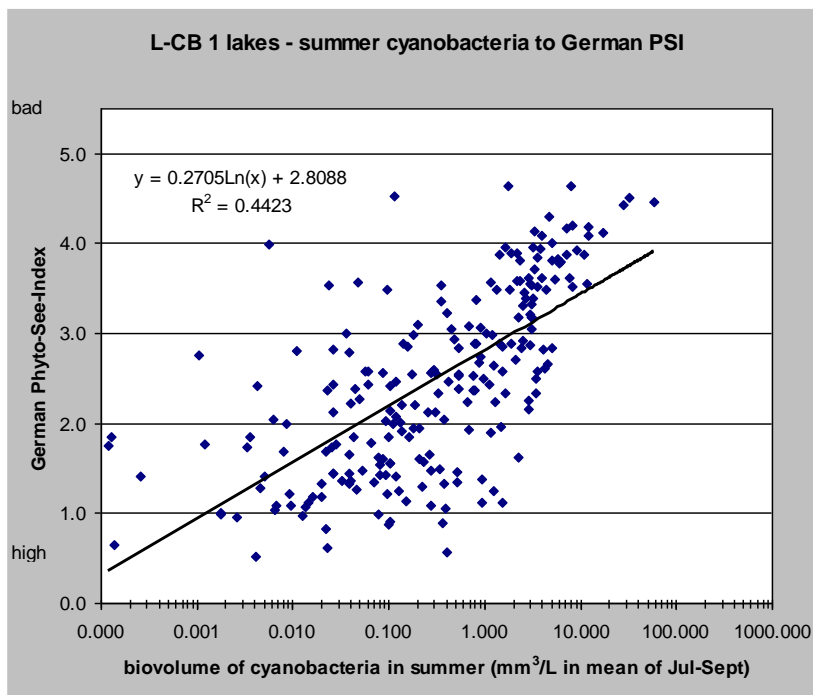

Figure B.5 Correlation between German Phyto-See-Index to the increasing biovolume of Cyanobacteria in shallow lowland lakes (intercalibration lake type L-CB 1).

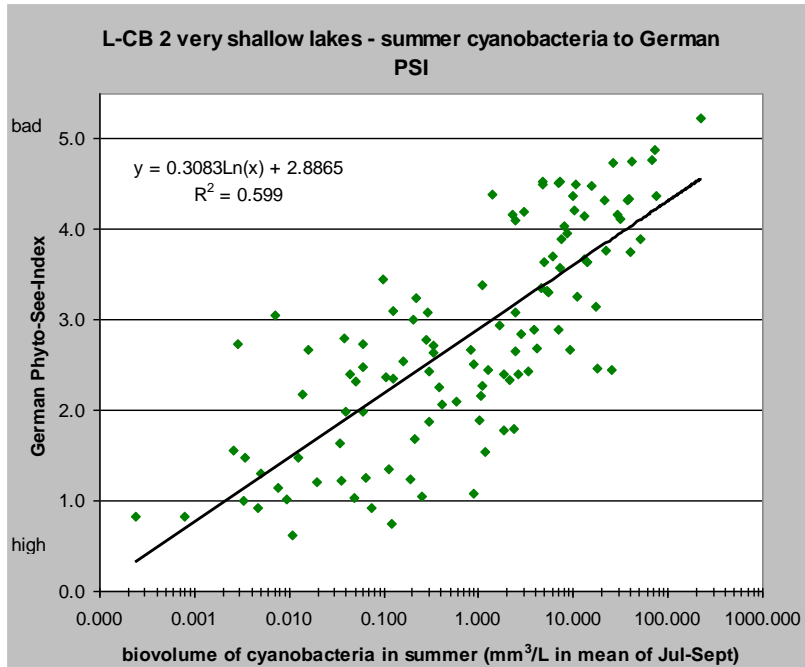

Figure B.6 Correlation between German Phyto-See-Index to the increasing biovolume of Cyanobacteria in very shallow lowland lakes (intercalibration lake type L-CB 2).

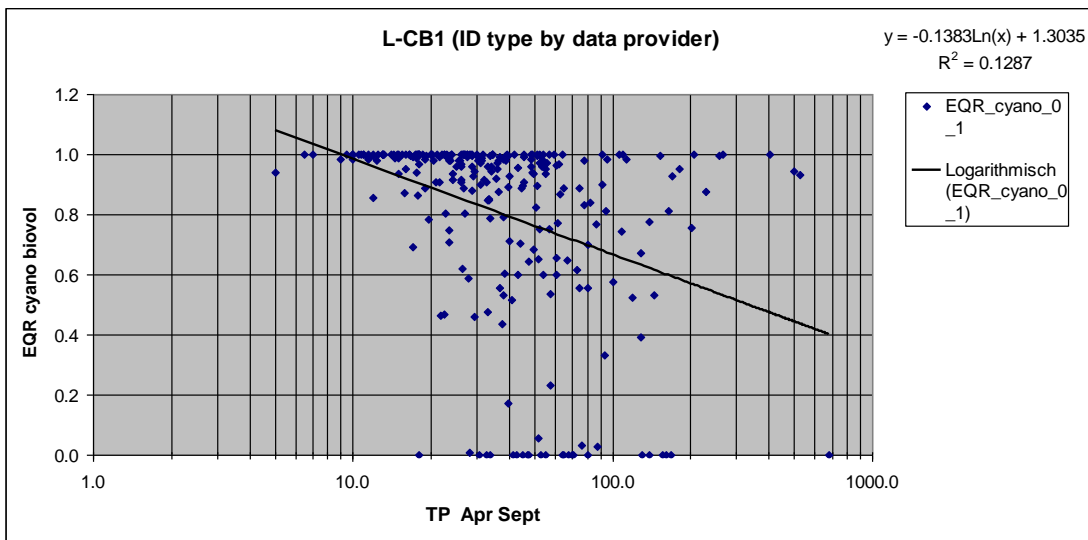

Figure B.7 Correlation between suggested Cyano-metric (WISER D 3-1-2) to pressure as "total phosphorus" (TP in $\mu\text{g/L}$) in shallow lowland lakes (intercalibration lake type L-CB 1).

Conclusion

The German assessment system already reflects common algal blooms and especially Cyanobacteria blooms by combining the assessment of biomass, algal class contribution and nuisance indicator taxa.

The further inclusion of a separate bloom metric into the PSI system would cause higher uncertainty to detect the pressure eutrophication

C. Relationships between National EQRs and Pressure

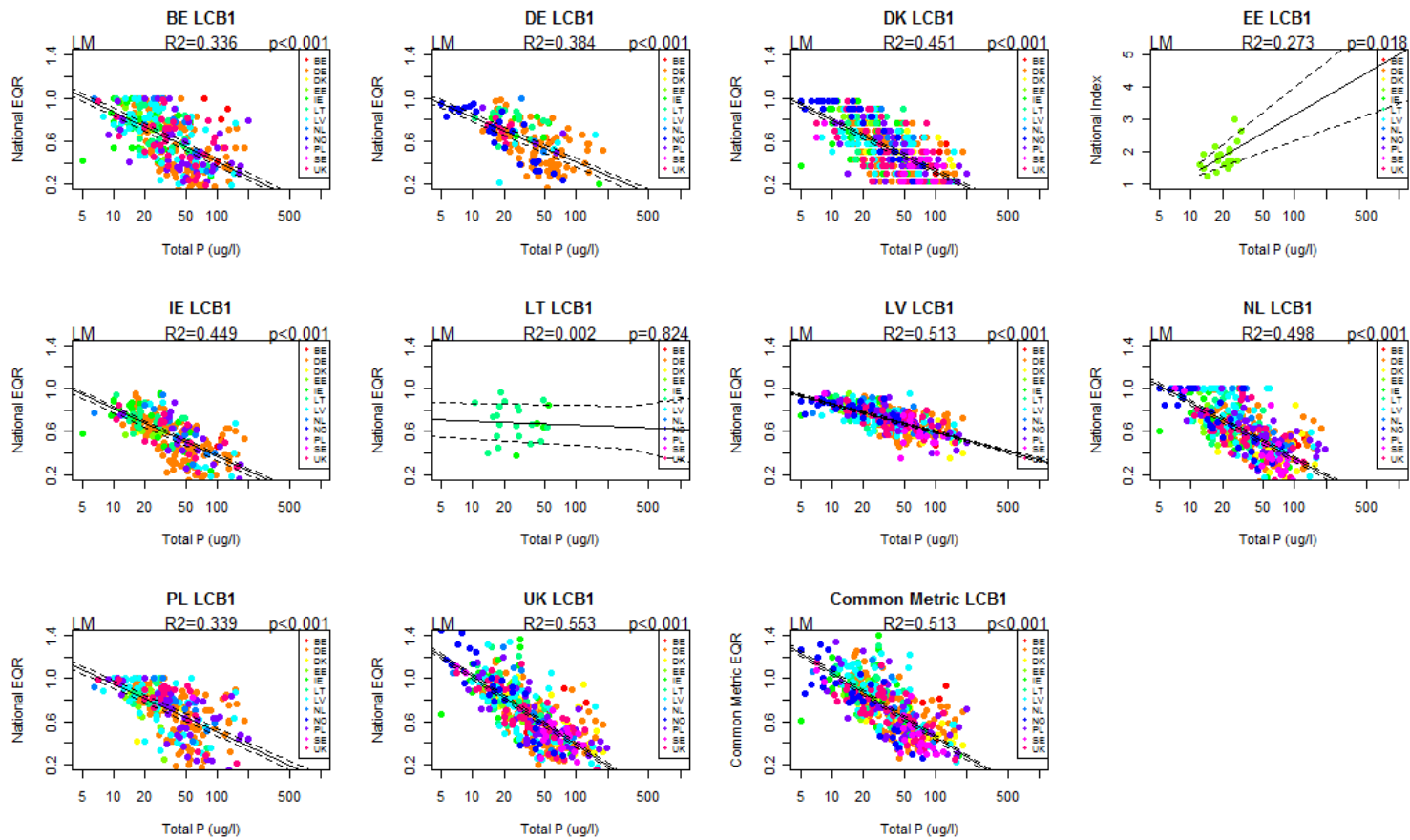

Intercalibration of biological elements for lake water bodies

Figure C.1 Relationship between phytoplankton EQR and mean growing season total phosphorus ($\mu\text{g/l}$) for LCB1 type, regression relationship fitted to data where total phosphorus $<200\mu\text{g/l}$.

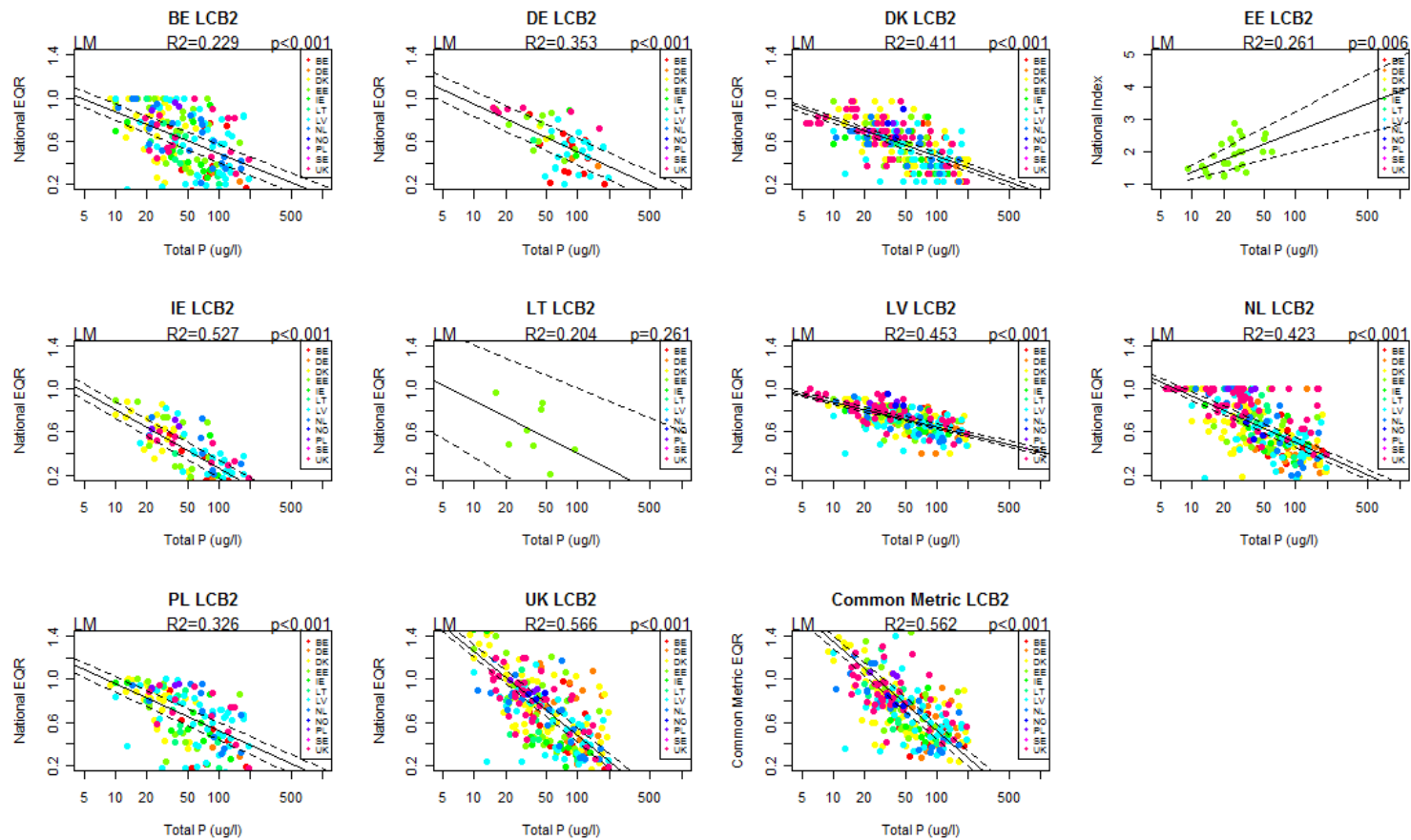

Intercalibration of biological elements for lake water bodies

Figure C.2 Relationship between phytoplankton EQR and mean growing season total phosphorus ($\mu\text{g/l}$) for LCB2 type, regression relationship fitted to data where total phosphorus $< 200\mu\text{g/l}$

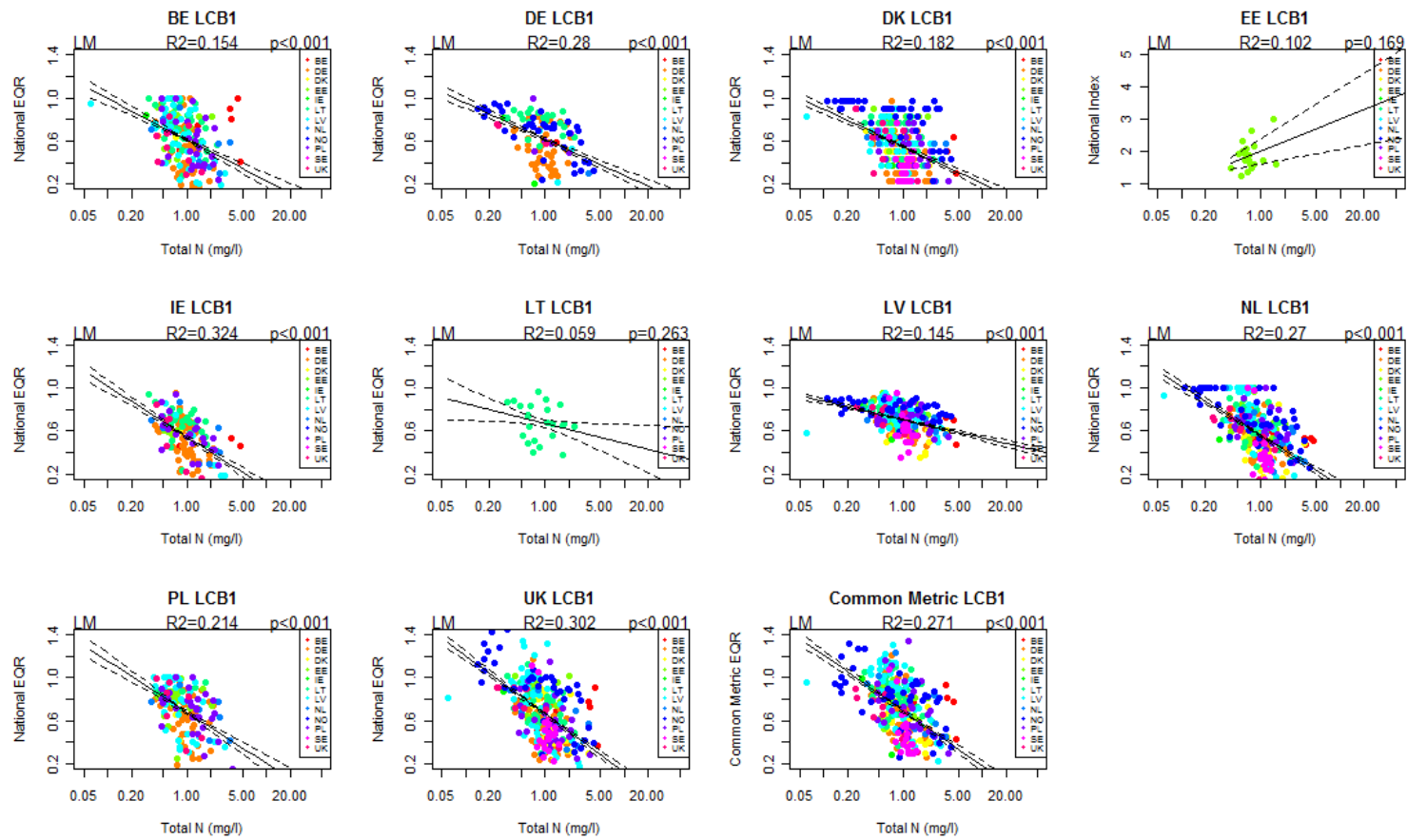

Intercalibration of biological elements for lake water bodies

Figure C.3 Relationship between phytoplankton EQR and mean growing season total nitrogen (mg/l) for LCB1 type, regression relationship fitted to data where total nitrogen <5.0 mg/l

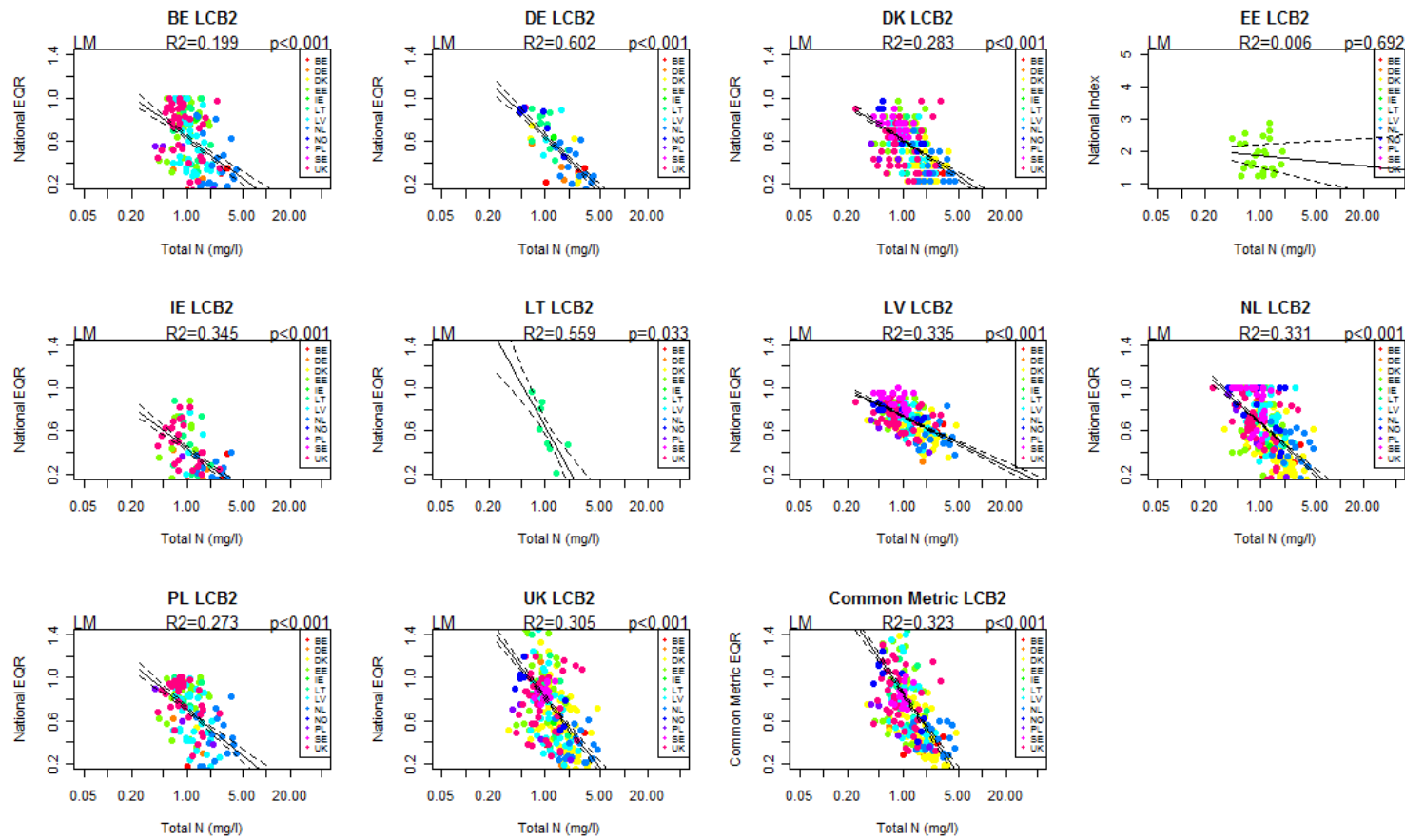

Figure C.4 Relationship between phytoplankton EQR and mean growing season total nitrogen (mg/l) for LCB2 type, regression relationship fitted to data where total nitrogen <5.0 mg/l

D. A description of ecological class boundaries for phytoplankton as proposed by the Central Baltic GIG for lake types LCB-1 and 2

Introduction

Two requirements for a boundary description are required by the intercalibration process:

1. Description of type-specific reference/biological benchmark communities of common IC type at GIG level, considering possible biogeographical differences;
2. Description of type-specific biological communities of common IC type at GIG level representing moderate deviation from reference conditions (good-moderate boundary), including associated environmental conditions. With more detail on page p31 of the guidance: "Similar to the benchmarking step the biological communities representing the "borderline" conditions between good and moderate ecological status have to be described. This shall be done using sites of the common dataset that fall into a selected boundary range (e.g. harmonisation band of national good-moderate boundaries expressed in common metric scale)."

The common metric was formed by averaging the chlorophyll *a* normalised EQR, using boundaries agreed during the first round of intercalibration, with a composition metric based on taxa - TP weighted averages. The CB-GIG used a mixed linear model, now referred to as "Continuous Benchmarking" to standardise the common metric. During the Amsterdam meeting of the CB-GIG held on the 16/6/2011 it was decided to use Indicator species analysis to provide an objective numeric description of the change in taxa composition and abundance across the common metric EQR scale with pressure.

Methods

Data at genus level that were used to assign values of the common metric and also national classifications in the CBGIG were extracted from the database. Average boundaries on the common metric scale were taken from the file Option2CompareV7_LCB1.xls sent on the 20/6/11 by the GIG lead (Geoff Phillips) for LCB1 (Table D.1) and "Option2CompareV7_LCB2.xls" for LCB2 (Table D.2).

Indicator species analysis (Dufrene and Legendre, 1997) for groups across the trophic scale centred on class boundaries was carried out using the software PC-ORD (McCune and Mefford, 1999). Groups were defined using boundaries provided (Geoff Phillips) for the common metric for LCB1 as H/G: 0.85, G/M: 0.633, and M/P: 0.476. The P/B boundary was estimated as halfway between poor and zero: 0.238. As continuous benchmarking was used the description of reference condition followed a similar approach assigning a boundary value of 1. The lakes in this group represent a benchmark towards reference condition but not a set of validated reference lakes, in line with the benchmarking approach. Lakes were selected as groups that were within plus and minus 0.25 as a proportion of class width from these boundaries. Similarly, for LCB2, groups were defined

using boundaries provided (Geoff Phillips) for the common metric: H/G: 0.857, G/M: 0.640, and M/P: 0.423. The calculation of these average common metric values excluded IE and LT which had stricter boundaries than other MS. The P/B boundary was estimated as halfway between poor and zero: 0.212. Continuous benchmarking was used so the description of reference condition followed a similar approach assigning a boundary value of 1.

Three components of indicator species analysis were presented to summarise the changes in taxonomic composition and abundance for class boundaries:

1. RELATIVE ABUNDANCE in group, % of perfect indication (average abundance of a given taxa in a given group of lakes over the average abundance of that taxa in all lakes expressed as a %).
2. RELATIVE FREQUENCY in group, % of perfect indication (% of lakes in given group where given taxa is present)
3. INDICATOR VALUES (% of perfect indication, based on combining the above values for relative abundance and relative frequency).

Lakes within class boundaries plus and minus 0.25 were also plotted against total biovolume, number of taxa and the log of 1+ biovolume of cyanophytes.

Results for LCB1 type

Median biovolume of phytoplankton at the class boundaries increased from 'reference condition' (using EQR = 1 as a surrogate) towards bad status: EQR 1: 1.2, H/G: 2.51, G/M: 4.68, M/P: 9.36, P/B: 24.46 (Table D.1). The number of taxa was not significantly different between class boundaries (ANOVA, $p = 0.128$, Table D.2). All class boundaries had a median number of taxa between 21 and 24 with the exception of the P/B boundary which had 13, although it was not significantly different from other class boundaries (Scheffe post hoc test: $p > 0.16$). Median biovolume of cyanophytes at the class boundaries increased from 'reference condition' towards bad status (Table D.3). Median values (untransformed) were EQR 1: 0.12, H/G: 0.15, G/M: 0.70, M/P: 3.17, P/B: 20.22. Log Cyanophytes+1 was significantly different between class boundaries (ANOVA, $p < 0.0001$). However, given the high variation in cyanophyte biovolume, only the M/P and P/B boundaries were significantly different from all other groups (Scheffe post hoc tests: $p < 0.002$). One exception was the G/M boundary being significantly different from the EQR1 boundary (Scheffe post hoc test: $p = 0.046$).

Intercalibration of biological elements for lake water bodies

Table D.1 Boundaries on the common metric scale for LCB1 as of 20/6/11

	Boundary values on standardised common metric scale											Average	FR
	UK	DE	EE	LV	BE	NL	DK	PL	IR	LT 3-9m	LT >9m		
Max	1.25	1.05	0.97	1.21	0.93	1.17	0.92	0.97	1.06	0.99	0.99	1.057	1.01
HG	0.79	0.88	0.85	0.91	0.80	0.95	0.78	0.81	0.88	0.84	0.86	0.850	0.86
GM	0.63	0.71	0.62	0.61	0.68	0.73	0.65	0.65	0.70	0.71	0.71	0.663	0.70
MP	0.47	0.53	0.39	0.31	0.55	0.51	0.51	0.49	0.52	0.63	0.64	0.476	0.55

Table D.2 Boundaries on the common metric scale for LCB2 as of 20/6/11. Average excludes IE and LT.

	Boundary values on standardised common metric scale											Average	Average	FRSt	LTAdj
	UK	DE	EE	LV	BE	NL	DK	PLst	LT	IRAdjSt					
Max	1.67	0.99	1.14	1.17	1.07	0.94	0.99	0.97	0.99	1.11	1.118	1.118	0.99	0.95	
HG	0.91	0.83	0.95	0.87	0.87	0.78	0.84	0.81	0.81	0.92	0.857	0.857	0.83	0.77	
GM	0.69	0.66	0.57	0.56	0.67	0.63	0.69	0.65	0.67	0.72	0.640	0.640	0.68	0.63	
MP	0.47	0.49	0.18	0.26	0.47	0.48	0.54	0.49	0.54	0.53	0.423	0.423	0.52	0.49	

Intercalibration of biological elements for lake water bodies

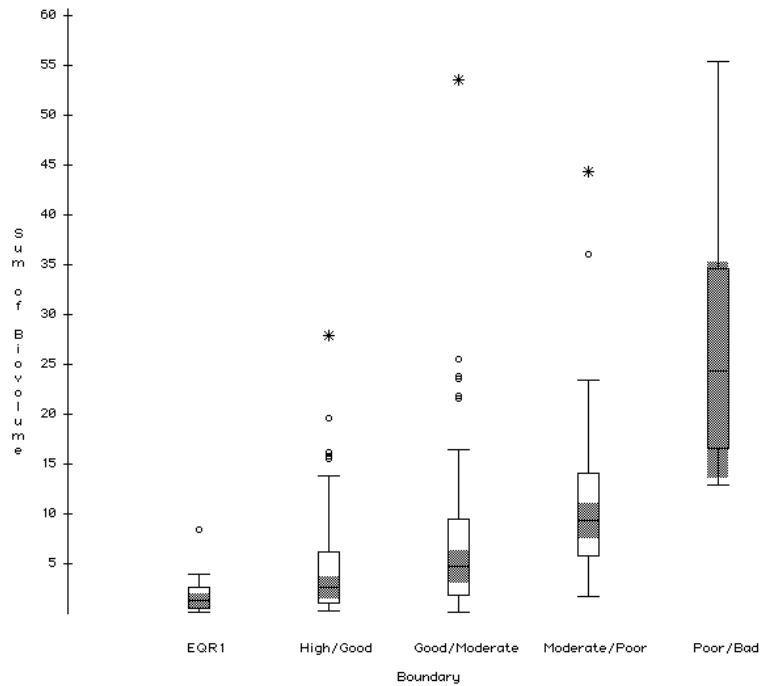

Figure D.1 Sum of phytoplankton biovolume for LCB1 lakes occurring within ± 0.25 of proposed common metric class boundaries. Plot rescaled to remove three extreme outliers in the Moderate/Poor boundary group. Shaded areas are 95% C.I. for comparing medians.

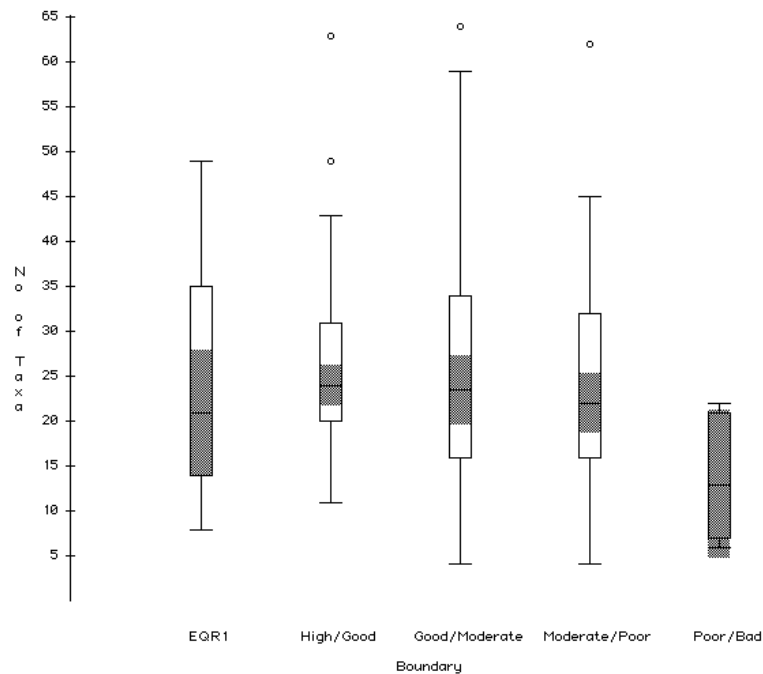

Figure D.2 Number of taxa (harmonised mostly to genus) for LCB1 lakes occurring within ± 0.25 of proposed common metric class boundaries.

Intercalibration of biological elements for lake water bodies

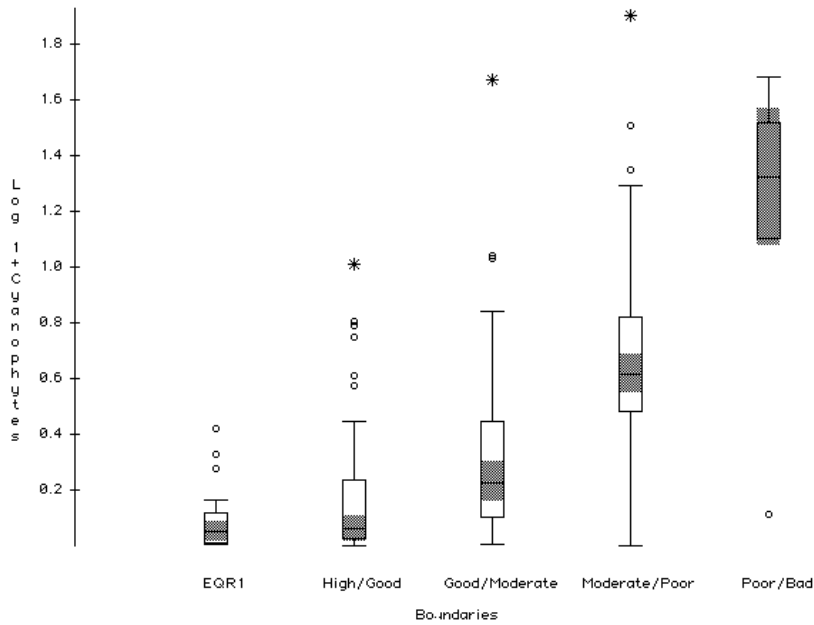

Figure D.3 Log Cyanophytes+1 for LCB1 lakes occurring within ± 0.25 of proposed common metric class boundaries.

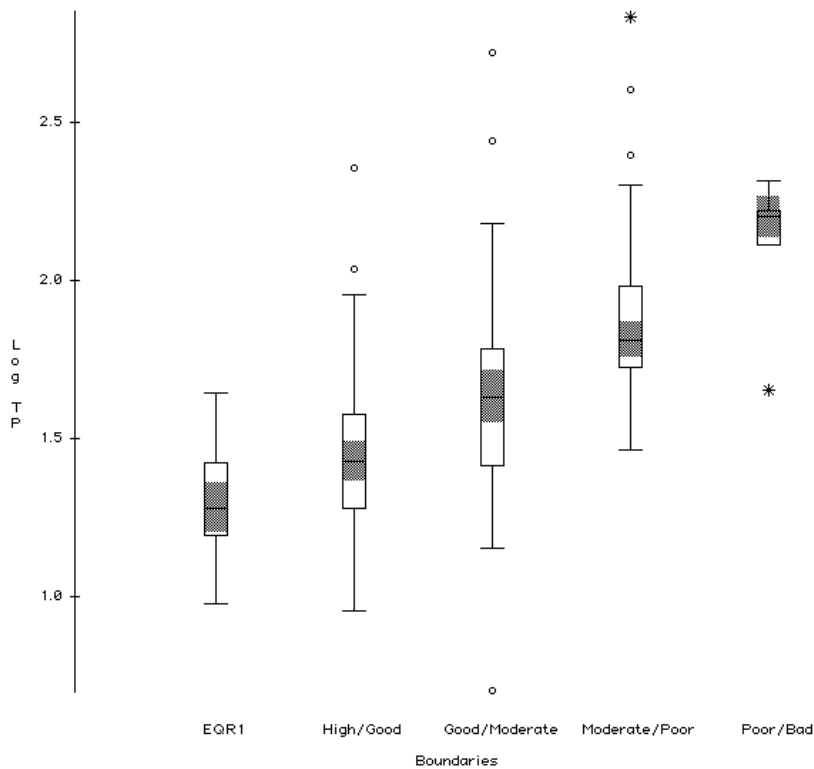

Figure D.4 Box plot of Log TP for LCB1 lakes occurring within ± 0.25 of proposed common metric class boundaries.

A description of the associated environmental conditions is also required by the guidance, specifically for the good/moderate boundary. A box plot of TP by boundary group shows a clear increase in TP across the boundaries (Figure D.4). Table D.3 and Table D.4 provide summary statistics of TP and chlorophyll *a* respectively.

Table D.3 Summary statistics of TP $\mu\text{g/l}$ for LCB1 boundary groups (boundary ± 0.25 class).

Group	Count	Mean	Median	StdDev	Lower 25%tile	Upper 75%tile
EQR1	23	21.2	19.0	10.2	15.5	26.4
High/Good	57	33.6	27.0	32.0	18.9	36.3
Good/Moderate	54	55.6	40.8	79.3	21.7	54.2
Moderate/Poor	57	91.2	64.5	101.3	51.3	94.0
Poor/Bad	7	146.3	160.0	50.3	136.1	165.3

Table D.4 Summary statistics of Chlorophyll *a* $\mu\text{g/l}$ for LCB1 boundary groups (boundary ± 0.25 class).

Group	Count	Mean	Median	StdDev	Lower 25%tile	Upper 75%tile
EQR1	23	4.4	3.6	1.9	2.9	5.8
High/Good	57	7.2	6.6	3.2	4.9	9.2
Good/Moderate	54	13.1	11.4	6.4	9.2	15.0
Moderate/Poor	57	31.4	27.2	22.2	19.8	37.2
Poor/Bad	7	80.9	68.2	37.6	55.3	96.0

Indicator species analysis was carried out for LCB1 on 228 taxa. The requirements of intercalibration include a description of reference (or alternative benchmark) as well as a description of the good/moderate boundary. The indicator values produced provide a composite value of abundance and frequency of occurrence for each taxa at each boundary (Table D.5). This should provide an objective description of the changes in phytoplankton across the proposed boundaries for LCB1.

LCB1 'Reference condition' (EQR of common metric equal to 1 ± 0.25 class)

Only Dinobryon and Tabellaria had a maximum indicator value (IV) recorded in the 'reference boundary' group that was greater than 10. Twenty-six other taxa had their maximum IV recorded in the reference group but were weaker indicators: Kephyrion, Willea, Cosmarium2, Merismopedia, Aphanocapsa, Cyclotella2, Puncticulata, Koliella, Bitrichia, Acanthoceras, Eunotia, Hyalotheca, Coenococcus, Tetrastrum2, Leptolyngbya, Cryptomonadales, Tetraëdriella, Gloeotila, Chroomonas, Pseudostaurastrum, Planctonema, Goniochloris, Gonium, Westella, Achnanthes, Katodinium (Table D.5). Four taxa that were highly indicative of the poor/bad boundary had an IV of 0 in the 'reference

boundary' group: Aphanizomenon, Planktothrix arg.grp, Anabaena flos.grp, Limnothrix. Despite these taxa frequently occurring in the reference group their relative abundance was notably low, therefore yielding an IV of 0.

LCB1 Good/Moderate boundary

For the good/moderate boundary twelve taxa had a maximum indicator value (IV) recorded that was greater than 10: Closterium, Asterionella, Monoraphidium3, Plagioselmis, Elakatothrix, Scenedesmus3, Staurastrum1, Monoraphidium1, Diatoma, Ankyra, Monoraphidium2, Pennales. Forty-seven other taxa had their maximum IV recorded in the good/moderate group but were weaker indicators: Oscillatoria, Anabaena lem.grp, Quadrigula, Actinastrum, Chroococcales, Golenkinia, Urosolenia, Tetrasporales, Cymbella, Merismopedia1, Chrysophyceae, Euglenophyceae, Staurodesmus, Carteria, Coenochloris, Pteromonas, Didymocystis, Sphaerocystis, Chromulinales, Cosmarium3, Phormidium, Planktosphaeria, Spirulina, Synechococcus, Pseudoquadrigula, Komvophoron, Cyndrotheca, Spirogyra, Coenocystis, Fragilariopsis, Pseudogoniochloris, Dinophyceae, Gloeotrichia, Achnanthidium, Spondylosium, Gonatozygon, Gloeocystis, Surirella, Tetraselmis, Cyanodictyon, Ulothrix, Pinnularia, Achroonema, Microcystis1, Dimorphococcus, Quadricoccus and Chlorophyta.

Taxa characteristic of other boundaries may be seen in Table D.5. Taxa are grouped from EQR1 to poor/bad depending on what class they were most indicative of (had their maximum IV in). Within each group taxa are ranked by IV.

Results for LCB2 type

Median biovolume of phytoplankton at the class boundaries increased from 'reference condition' (using EQR = 1 as a surrogate) towards bad status: EQR 1: 2.48, H/G: 3.68, G/M: 8.95, M/P: 14.63, P/B: 44.98 (Table D.5). Class boundaries had a median number of taxa between 27 and 33 with the exception of the P/B boundary which had 10 (Table D.6). The number of taxa was significantly different only between the G/M and P/B boundary groups (Scheffe post hoc test: $p = 0.034$).

Median biovolume of cyanophytes at the class boundaries increased from H/G towards P/B status (Figure D.3). Values at EQR 1 were notably higher than those at H/G. It is likely that this boundary is unreliable for defining a benchmark for LCB2 lakes owing to the low n of 8. Median values (untransformed) were EQR 1: 0.64, H/G: 0.15, G/M: 1.83, M/P: 5.97, P/B: 13.25. Log Cyanophytes+1 was significantly different between class boundaries (ANOVA, $p < 0.0001$). Given the high variation in cyanophyte biovolume, only the M/P and P/B boundaries were significantly different from all other groups (Scheffe post hoc tests: $p < 0.02$).

Intercalibration of biological elements for lake water bodies

Table D.5 Results of indicator species analysis carried out for LCB1 lakes. Groups were defined by lakes occurring within ± 0.25 of proposed common metric class boundaries for EQR 1, High/Good, Good/Moderate, Moderate/Poor, Poor/Bad. Taxa are grouped from EQR1 to poor/bad depending on what class they were most indicative of (had their maximum IV in). Within each group taxa are ranked by IV. A horizontal line indicates the transition between groups.

	Relative abundance					Relative frequency					Indicator values				
	EQR 1	H/G	G/M	M/P	P/B	EQR 1	H/G	G/M	M/P	P/B	EQR 1	H/G	G/M	M/P	P/B
Dinobryon	46	32	18	3	0	83	72	52	21	0	38	23	9	1	0
Tabellaria	66	3	30	1	0	17	11	11	7	0	12	0	3	0	0
Kephyrion	74	15	1	10	0	13	9	9	7	0	10	1	0	1	0
Willea	48	39	7	6	0	17	5	4	2	0	8	2	0	0	0
Cosmarium2	96	3	0	0	0	9	4	4	2	0	8	0	0	0	0
Merismopedia	38	12	48	2	0	22	5	6	2	0	8	1	3	0	0
Aphanocapsa	16	4	4	48	28	48	32	24	16	14	8	1	1	8	4
Cyclotella2	89	11	0	1	0	9	9	6	12	0	8	1	0	0	0
Puncticulata	77	11	4	9	0	9	4	2	2	0	7	0	0	0	0
Koliella	38	33	0	29	0	17	12	6	9	0	7	4	0	3	0
Bitrichia	36	30	33	1	0	17	14	4	2	0	6	4	1	0	0
Acanthoceras	55	11	24	9	0	9	7	7	9	0	5	1	2	1	0
Eunotia	100	0	0	0	0	4	0	0	0	0	4	0	0	0	0
Hyalotheca	100	0	0	0	0	4	0	0	0	0	4	0	0	0	0
Coenococcus	100	0	0	0	0	4	0	0	0	0	4	0	0	0	0
Tetrastrum2	96	1	3	0	0	4	4	2	2	0	4	0	0	0	0
Leptolyngbya	94	6	0	0	0	4	2	0	0	0	4	0	0	0	0
Cryptomonadales	94	6	0	0	0	4	2	2	0	0	4	0	0	0	0
Tetraëdriella	77	0	23	0	0	4	0	2	0	0	3	0	0	0	0

Intercalibration of biological elements for lake water bodies

	Relative abundance					Relative frequency					Indicator values				
	EQR 1	H/G	G/M	M/P	P/B	EQR 1	H/G	G/M	M/P	P/B	EQR 1	H/G	G/M	M/P	P/B
Gloeotila	79	2	0	19	0	4	2	0	2	0	3	0	0	0	0
Chroomonas	75	21	4	0	0	4	4	4	0	0	3	1	0	0	0
Pseudostaurastrum	59	0	0	41	0	4	0	0	2	0	3	0	0	1	0
Planctonema	58	15	18	1	9	4	5	2	2	14	3	1	0	0	1
Goniochloris	58	7	1	34	0	4	2	2	4	0	3	0	0	1	0
Gonium	26	6	41	27	0	9	2	4	2	0	2	0	2	0	0
Westella	39	0	0	61	0	4	0	0	2	0	2	0	0	1	0
Achnanthes	35	14	50	0	0	4	2	2	0	0	2	0	1	0	0
Katodinium	23	25	52	0	0	4	2	2	0	0	1	0	1	0	0
Pediastrum	5	69	6	16	4	43	40	46	46	29	2	28	3	7	1
Cyclotella1	4	39	3	16	37	70	61	35	23	29	3	24	1	4	10
Gymnodinium	3	74	3	4	15	17	30	30	23	14	1	22	1	1	2
Fragilaria	19	27	14	35	6	70	65	57	42	29	13	18	8	15	2
Peridinium	6	26	11	28	30	61	67	44	51	43	3	17	5	14	13
Aphanothece	26	46	16	12	0	22	35	13	9	0	6	16	2	1	0
Chlorococcales	4	48	1	5	42	35	33	26	21	14	1	16	0	1	6
Tetraedron	2	44	7	39	8	48	35	39	37	29	1	15	3	14	2
Ochromonas	3	43	4	51	0	9	25	6	4	0	0	11	0	2	0
Crucigenia	8	39	24	30	0	35	26	30	14	0	3	10	7	4	0
Pandorina	4	43	37	16	0	17	23	20	12	0	1	10	8	2	0
Snowella	5	24	6	35	31	22	35	19	12	14	1	8	1	4	4
Glenodinium	18	74	2	6	0	4	11	2	4	0	1	8	0	0	0

Intercalibration of biological elements for lake water bodies

	Relative abundance					Relative frequency					Indicator values				
	EQR 1	H/G	G/M	M/P	P/B	EQR 1	H/G	G/M	M/P	P/B	EQR 1	H/G	G/M	M/P	P/B
Golenkiniopsis	0	100	0	0	0	0	7	0	0	0	0	7	0	0	0
Discostella	0	73	27	0	0	13	9	6	2	0	0	6	1	0	0
Melosira	19	77	4	0	0	4	7	4	0	0	1	5	0	0	0
Planktothrix grp	0	100	0	0	0	0	5	0	0	0	0	5	0	0	0
Gloeocapsa	0	100	0	0	0	0	5	0	0	0	0	5	0	0	0
Phacus	1	57	14	28	0	4	9	6	11	0	0	5	1	3	0
Uroglena	0	72	28	0	0	0	7	7	2	0	0	5	2	0	0
Chlorella	0	69	16	15	0	4	7	9	2	0	0	5	2	0	0
Chrysococcus	27	44	4	24	0	4	9	2	5	0	1	4	0	1	0
Cocconeis	3	52	3	42	0	4	7	6	4	0	0	4	0	1	0
Tribonema	0	41	1	58	0	0	9	2	5	0	0	4	0	3	0
Gomphonema	0	99	1	0	0	0	4	2	0	0	0	3	0	0	0
Ulotrichales	31	60	9	0	0	4	5	2	0	0	1	3	0	0	0
Tetrastrum3	0	60	0	40	0	0	5	0	5	0	0	3	0	2	0
Gyrosigma	0	83	17	0	0	0	4	2	0	0	0	3	0	0	0
Radiocystis	6	81	0	14	0	4	4	0	2	0	0	3	0	0	0
Oscillatoriales	0	30	13	57	0	9	7	4	2	0	0	2	0	1	0
Raphidocelis	25	57	17	0	0	4	4	4	0	0	1	2	1	0	0
Geitlerinema	0	100	0	0	0	0	2	0	0	0	0	2	0	0	0
Pseudokephyrion	0	100	0	0	0	0	2	0	2	0	0	2	0	0	0
Eutetramorus	0	100	0	0	0	0	2	0	0	0	0	2	0	0	0
Volvox	0	100	0	0	0	0	2	0	0	0	0	2	0	0	0

Intercalibration of biological elements for lake water bodies

	Relative abundance					Relative frequency					Indicator values				
	EQR 1	H/G	G/M	M/P	P/B	EQR 1	H/G	G/M	M/P	P/B	EQR 1	H/G	G/M	M/P	P/B
Pseudopediastrum	0	100	0	0	0	0	2	0	0	0	0	2	0	0	0
Spermatozopsis	0	100	0	0	0	0	2	0	0	0	0	2	0	0	0
Geminella	0	100	0	0	0	0	2	0	0	0	0	2	0	0	0
Radiococcus	0	100	0	0	0	0	2	0	0	0	0	2	0	0	0
Gloeococcus	0	100	0	0	0	0	2	0	0	0	0	2	0	0	0
Characiopsis	0	100	0	0	0	0	2	0	0	0	0	2	0	0	0
Mayamaea	19	45	36	0	0	4	4	4	0	0	1	2	1	0	0
Rhabdogloea	0	79	21	0	0	0	2	6	0	0	0	1	1	0	0
Cymatopleura	0	71	12	17	0	0	2	2	2	0	0	1	0	0	0
Closterium	1	10	71	18	1	52	51	52	46	14	0	5	37	8	0
Asterionella	4	8	56	32	0	70	74	61	40	0	3	6	34	13	0
Monoraphidium3	0	30	68	1	1	22	26	39	35	29	0	8	27	0	0
Plagioselmis	22	16	29	19	15	74	81	76	68	57	16	13	22	13	8
Elakatothrix	0	0	78	22	0	30	30	24	12	0	0	0	19	3	0
Scenedesmus3	1	0	57	41	0	30	19	30	33	0	0	0	17	14	0
Staurastrum1	0	32	36	32	0	17	46	44	16	14	0	15	16	5	0
Monoraphidium1	0	0	98	1	0	0	16	15	14	14	0	0	15	0	0
Diatoma	0	2	73	25	0	4	11	19	16	0	0	0	14	4	0
Ankyra	18	14	59	9	0	13	18	20	11	0	2	2	12	1	0
Monoraphidium2	0	1	89	1	9	4	14	13	5	14	0	0	12	0	1
Pennales	15	6	77	2	0	9	12	15	5	0	1	1	11	0	0
Oscillatoria	1	1	33	64	0	4	12	30	14	14	0	0	10	9	0

Intercalibration of biological elements for lake water bodies

	Relative abundance					Relative frequency					Indicator values				
	EQR 1	H/G	G/M	M/P	P/B	EQR 1	H/G	G/M	M/P	P/B	EQR 1	H/G	G/M	M/P	P/B
Anabaena lem.grp	5	4	58	33	0	13	19	17	11	0	1	1	10	3	0
Quadrigula	0	22	77	1	0	13	14	11	2	0	0	3	9	0	0
Actinastrum	0	1	90	10	0	0	7	9	18	0	0	0	8	2	0
Chroococcales	2	1	76	20	0	13	2	9	7	0	0	0	7	1	0
Golenkinia	0	5	95	0	0	0	7	7	0	0	0	0	7	0	0
Urosolenia	5	1	93	0	0	9	16	7	4	0	0	0	7	0	0
Tetrasporales	3	16	74	8	0	9	11	9	7	0	0	2	7	1	0
Cymbella	16	0	78	6	0	4	0	7	4	0	1	0	6	0	0
Merismopedia1	0	0	77	23	0	4	7	7	12	0	0	0	6	3	0
Chrysophyceae	21	1	77	2	0	17	9	7	7	0	4	0	6	0	0
Euglenophyceae	0	0	100	0	0	0	0	6	0	0	0	0	6	0	0
Staurodesmus	0	0	100	0	0	0	0	6	0	0	0	0	6	0	0
Carteria	0	1	88	11	0	0	4	6	4	0	0	0	5	0	0
Coenochloris	2	37	61	0	0	4	9	7	0	0	0	3	5	0	0
Pteromonas	0	1	78	21	0	0	2	6	5	0	0	0	4	1	0
Didymocystis	0	0	100	0	0	0	0	4	0	0	0	0	4	0	0
Sphaerocystis	13	22	48	17	0	9	12	7	5	0	1	3	4	1	0
Chromulinales	0	3	97	0	0	0	2	4	0	0	0	0	4	0	0
Cosmarium3	27	9	64	0	0	4	2	6	0	0	1	0	4	0	0
Phormidium	6	11	59	24	0	4	4	6	2	0	0	0	3	0	0
Planktosphaeria	15	14	55	16	0	9	4	4	2	0	1	0	2	0	0
Spirulina	0	0	100	0	0	0	0	2	0	0	0	0	2	0	0

Intercalibration of biological elements for lake water bodies

	Relative abundance					Relative frequency					Indicator values				
	EQR 1	H/G	G/M	M/P	P/B	EQR 1	H/G	G/M	M/P	P/B	EQR 1	H/G	G/M	M/P	P/B
Synechococcus	0	0	100	0	0	0	0	2	0	0	0	0	2	0	0
Pseudoquadrigula	0	0	100	0	0	0	0	2	0	0	0	0	2	0	0
Komvophoron	0	0	100	0	0	0	0	2	0	0	0	0	2	0	0
Cylindrotheca	0	0	100	0	0	0	0	2	0	0	0	0	2	0	0
Spirogyra	0	0	100	0	0	0	0	2	0	0	0	0	2	0	0
Coenocystis	0	0	100	0	0	0	0	2	0	0	0	0	2	0	0
Fragilariopsis	0	0	100	0	0	0	0	2	0	0	0	0	2	0	0
Pseudogoniochloris	0	0	100	0	0	0	0	2	0	0	0	0	2	0	0
Dinophyceae	0	0	100	0	0	0	0	2	0	0	0	0	2	0	0
Gloeotrichia	0	0	100	0	0	0	0	2	0	0	0	0	2	0	0
Achnanthydium	0	0	100	0	0	0	0	2	0	0	0	0	2	0	0
Spondylosium	0	0	100	0	0	0	0	2	0	0	0	0	2	0	0
Gonatozygon	0	0	100	0	0	0	0	2	0	0	0	0	2	0	0
Gloeocystis	0	0	100	0	0	0	0	2	0	0	0	0	2	0	0
Surirella	0	2	98	0	0	0	2	2	0	0	0	0	2	0	0
Tetraselmis	0	2	95	3	0	0	4	2	2	0	0	0	2	0	0
Cyanodictyon	0	5	94	1	0	0	7	2	4	0	0	0	2	0	0
Ulothrix	0	0	94	6	0	0	0	2	2	0	0	0	2	0	0
Pinnularia	0	61	39	0	0	0	2	4	0	0	0	1	1	0	0
Achroonema	3	0	77	20	0	4	2	2	5	0	0	0	1	1	0
Microcystis1	0	34	59	7	0	0	2	2	2	0	0	1	1	0	0
Dimorphococcus	0	38	62	0	0	0	2	2	0	0	0	1	1	0	0

Intercalibration of biological elements for lake water bodies

	Relative abundance					Relative frequency					Indicator values				
	EQR 1	H/G	G/M	M/P	P/B	EQR 1	H/G	G/M	M/P	P/B	EQR 1	H/G	G/M	M/P	P/B
Quadricoccus	6	39	55	0	0	4	2	2	0	0	0	1	1	0	0
Chlorophyta	0	13	28	59	0	0	5	4	2	0	0	1	1	1	0
Ceratium	4	9	26	54	8	74	74	80	75	29	3	6	21	40	2
Planktolyngbya	0	2	3	94	1	13	21	22	33	14	0	0	1	31	0
Coelastrum	0	0	3	88	9	17	25	31	30	29	0	0	1	26	2
Nitzschia	1	1	48	50	0	52	26	37	49	0	1	0	18	25	0
Dictyosphaerium	0	8	0	91	0	9	19	13	26	14	0	2	0	24	0
Woronichinia	10	4	3	83	0	13	12	11	26	0	1	0	0	22	0
Centrales	3	3	9	45	40	13	28	39	46	29	0	1	3	21	11
Microcystis3	6	8	29	57	0	26	35	31	33	0	1	3	9	19	0
Chlamydomonas	4	27	5	57	7	43	32	39	33	43	2	9	2	19	3
Cosmarium1	3	4	11	82	0	30	18	22	23	0	1	1	2	19	0
Anabaena grp	1	18	16	53	13	35	40	46	35	29	0	7	7	19	4
Oocystis	31	9	8	51	1	48	56	52	32	14	15	5	4	16	0
Mallomonas	1	10	2	87	0	13	23	19	18	0	0	2	0	15	0
Aulacoseira it.is.grp	1	3	40	52	4	17	18	28	28	14	0	0	11	15	1
Mougeotia	0	1	31	68	0	0	12	17	21	0	0	0	5	14	0
Microcystis2	2	9	8	81	0	22	23	19	18	0	0	2	2	14	0
Cyanophyceae	0	0	0	100	0	4	4	9	14	0	0	0	0	14	0
Schroederia	0	0	7	93	0	4	5	6	14	0	0	0	0	13	0
Stephanodiscus	5	4	5	49	37	48	44	33	26	29	2	2	2	13	11
Chrysochromulina	1	14	27	41	17	4	14	17	30	14	0	2	4	12	2

Intercalibration of biological elements for lake water bodies

	Relative abundance					Relative frequency					Indicator values				
	EQR 1	H/G	G/M	M/P	P/B	EQR 1	H/G	G/M	M/P	P/B	EQR 1	H/G	G/M	M/P	P/B
Scenedesmus1	0	1	1	98	0	9	9	7	12	0	0	0	0	12	0
Peridiniopsis	1	8	1	90	0	9	7	2	12	0	0	1	0	11	0
Kirchneriella	14	20	4	62	0	17	16	11	18	0	3	3	0	11	0
Euglena	3	7	5	73	12	13	7	11	14	14	0	1	1	10	2
Rhodomonas	0	5	8	87	0	0	5	2	11	0	0	0	0	9	0
Ankistrodesmus	0	0	1	99	0	9	4	4	9	0	0	0	0	9	0
Phytoplankton, unid.	4	13	13	31	38	30	30	43	28	14	1	4	6	9	5
Staurastrum2	1	6	11	82	0	9	4	11	11	0	0	0	1	9	0
Navicula	0	3	0	97	0	22	23	15	9	0	0	1	0	8	0
Tetrastrum1	0	0	5	95	0	0	4	4	9	0	0	0	0	8	0
Gomphosphaeria	0	2	11	87	0	9	9	6	9	0	0	0	1	8	0
Coelosphaerium	8	3	5	84	0	13	11	11	9	0	1	0	1	7	0
Treubaria	0	0	4	96	0	0	4	7	7	0	0	0	0	7	0
Lagerheimia	0	40	0	60	0	13	7	7	11	0	0	3	0	6	0
Cyclostephanos	0	14	24	57	5	0	9	4	11	14	0	1	1	6	1
Chromulina	0	0	0	100	0	0	0	0	5	0	0	0	0	5	0
Eudorina	0	29	17	54	0	0	11	6	9	0	0	3	1	5	0
Pseudopedinella	1	5	6	88	0	4	5	6	5	0	0	0	0	5	0
Closteriopsis	0	19	20	61	0	0	4	9	7	14	0	1	2	4	0
Anabaenopsis	0	21	0	79	0	0	2	0	5	0	0	0	0	4	0
Staurosira	2	20	3	76	0	4	4	4	5	0	0	1	0	4	0
Micractinium	0	1	30	69	0	0	2	7	5	0	0	0	2	4	0

Intercalibration of biological elements for lake water bodies

	Relative abundance					Relative frequency					Indicator values				
	EQR 1	H/G	G/M	M/P	P/B	EQR 1	H/G	G/M	M/P	P/B	EQR 1	H/G	G/M	M/P	P/B
Erkenia	0	20	10	70	0	0	5	2	5	0	0	1	0	4	0
Actinocyclus	0	59	0	41	0	0	4	0	9	0	0	2	0	4	0
Synura	1	29	2	68	0	13	11	9	5	0	0	3	0	4	0
Nephrocytium	0	0	1	99	0	0	2	4	4	14	0	0	0	3	0
Pseudosphaerocystis	0	0	1	99	0	0	2	2	4	0	0	0	0	3	0
Monomorphina	0	0	0	100	0	0	0	0	4	0	0	0	0	4	0
Raphidiopsis	0	0	0	100	0	0	0	0	4	0	0	0	0	4	0
Chlorogonium	0	0	0	100	0	0	0	0	4	0	0	0	0	4	0
Botryococcus	1	1	0	98	0	9	11	4	4	0	0	0	0	3	0
Amphora	4	23	36	36	0	9	2	4	7	0	0	0	1	3	0
Stichococcus	0	21	26	53	0	0	2	2	4	0	0	0	0	2	0
Euastrum	0	0	0	100	0	0	0	0	2	0	0	0	0	2	0
Tetrachlorella	0	0	0	100	0	0	0	0	2	0	0	0	0	2	0
Binuclearia	0	0	0	100	0	0	0	0	2	0	0	0	0	2	0
Kolkwitzia	0	0	0	100	0	0	0	0	2	0	0	0	0	2	0
Rhoicosphenia	0	0	0	100	0	0	0	0	2	0	0	0	0	2	0
Chlorotetraedron	0	0	0	100	0	0	0	0	2	0	0	0	0	2	0
Diplopsalis	0	0	0	100	0	0	0	0	2	0	0	0	0	2	0
Lyngbya	0	0	0	100	0	0	0	4	2	0	0	0	0	2	0
Diplochlois	0	0	0	100	0	0	0	0	2	0	0	0	0	2	0
Stichogloea	0	0	0	100	0	0	0	0	2	0	0	0	0	2	0
Lepocinclis	0	0	0	100	0	0	0	0	2	0	0	0	0	2	0

Intercalibration of biological elements for lake water bodies

	Relative abundance					Relative frequency					Indicator values				
	EQR 1	H/G	G/M	M/P	P/B	EQR 1	H/G	G/M	M/P	P/B	EQR 1	H/G	G/M	M/P	P/B
Amphikrikos	0	0	0	100	0	0	0	0	2	0	0	0	0	2	0
Cyanogranis	0	0	0	100	0	0	0	0	2	0	0	0	0	2	0
Nephrodiella	0	0	0	100	0	0	0	0	2	0	0	0	0	2	0
Xanthidium	0	0	0	100	0	0	0	0	2	0	0	0	0	2	0
Epipyxis	0	0	0	100	0	0	0	0	2	0	0	0	0	2	0
Stauroneis	0	10	0	90	0	0	4	0	2	0	0	0	0	2	0
Siderocelis	0	6	0	94	0	0	2	0	2	0	0	0	0	2	0
Prasinophyceae	0	8	0	92	0	0	2	0	2	0	0	0	0	2	0
Romeria	0	13	0	87	0	0	4	0	2	0	0	0	0	2	0
Centritractus	15	1	0	84	0	4	2	0	2	0	1	0	0	1	0
Merismopedia2	0	5	15	80	0	0	2	4	2	0	0	0	1	1	0
Rhabdoderma	0	1	41	58	0	0	2	2	2	0	0	0	1	1	0
Paulschulzia	0	18	37	46	0	0	2	2	2	0	0	0	1	1	0
Aphanizomenon	0	1	4	13	82	43	47	61	79	86	0	0	2	11	70
Planktothrix arg.grp	0	0	2	6	91	35	23	37	46	57	0	0	1	3	52
Anabaena flos.grp	1	1	6	25	67	43	32	30	51	71	0	0	2	12	48
Limnothrix	0	3	3	16	79	22	16	24	35	57	0	0	1	5	45
Trachelomonas	0	3	4	3	90	13	28	30	26	43	0	1	1	1	38
Ulnaria	1	7	9	16	66	57	56	46	47	57	0	4	4	8	38
Pseudanabaena	0	5	1	8	85	17	32	37	53	43	0	2	1	4	37
Cryptomonas	8	11	20	22	38	87	91	91	82	86	7	10	18	18	33
Scenedesmus2	0	31	29	11	29	30	37	56	49	57	0	12	16	5	16

Intercalibration of biological elements for lake water bodies

	Relative abundance					Relative frequency					Indicator values				
	EQR 1	H/G	G/M	M/P	P/B	EQR 1	H/G	G/M	M/P	P/B	EQR 1	H/G	G/M	M/P	P/B
Aulacoseira gran.grp	0	0	2	5	93	26	28	41	40	14	0	0	1	2	13
Peridinales	0	0	4	4	91	0	0	9	2	14	0	0	0	0	13
Chroococcus	4	2	3	8	82	57	25	24	23	14	2	1	1	2	12
Cryptophyceae	1	2	10	8	80	17	9	9	11	14	0	0	1	1	11
Volvocales	0	2	8	10	80	0	7	9	5	14	0	0	1	1	11
Nostocales	0	0	21	0	79	0	0	4	0	14	0	0	1	0	11
Crucigeniella	2	13	9	0	76	9	9	9	4	14	0	1	1	0	11
Trichormus	1	1	7	19	72	4	7	17	5	14	0	0	1	1	10
Cylindrospermopsis	0	0	1	30	70	0	0	2	7	14	0	0	0	2	10
Aulacoseira alp.grp	0	31	0	19	49	0	4	2	4	14	0	1	0	1	7
Phacotus	10	17	6	29	39	26	16	7	16	14	3	3	0	5	6

Intercalibration of biological elements for lake water bodies

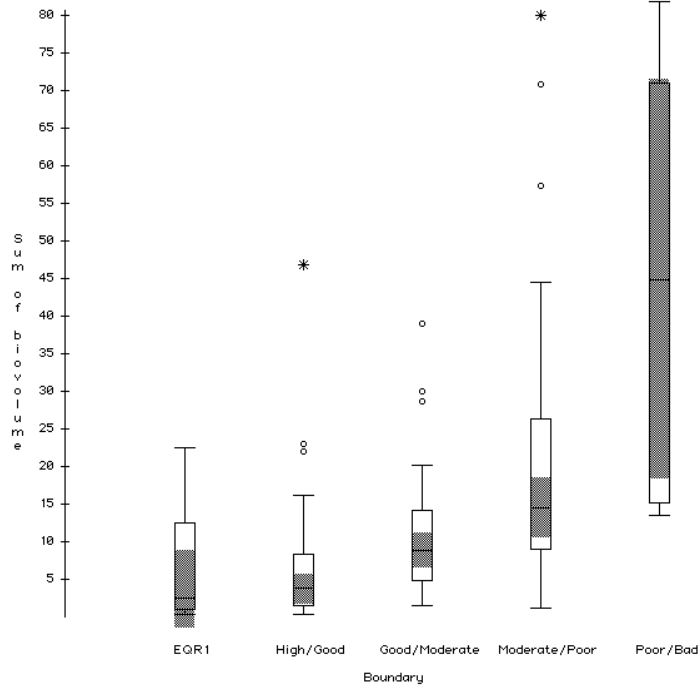

Figure D.5 Sum of Phytoplankton biovolume for LCB2 lakes occurring within ± 0.25 of proposed common metric class boundaries. Plot rescaled to remove one extreme outlier in the Moderate/Poor and Poor/Bad boundary group. Shaded areas are 95% C.I. for comparing medians.

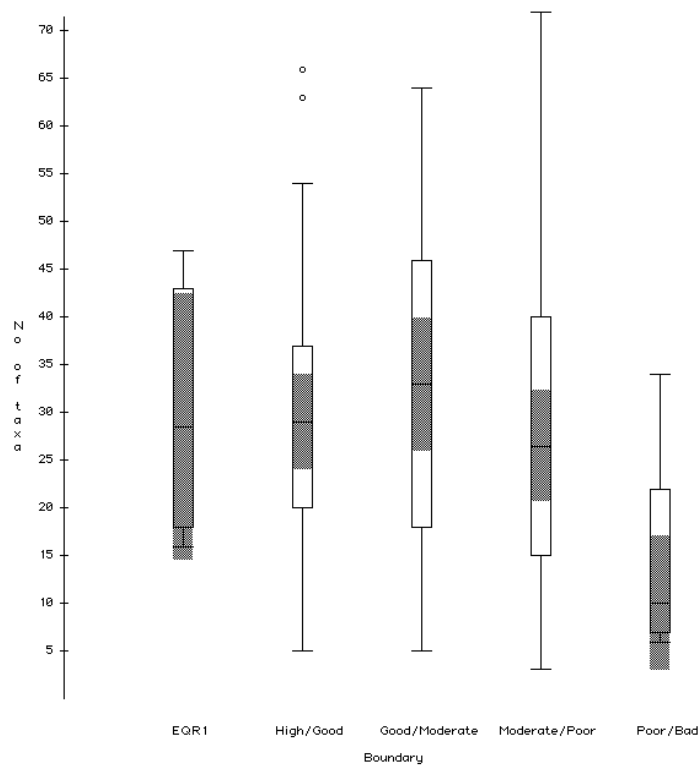

Figure D.6 Number of taxa (harmonised mostly to genus) for LCB2 lakes occurring within ± 0.25 of proposed common metric class boundaries.

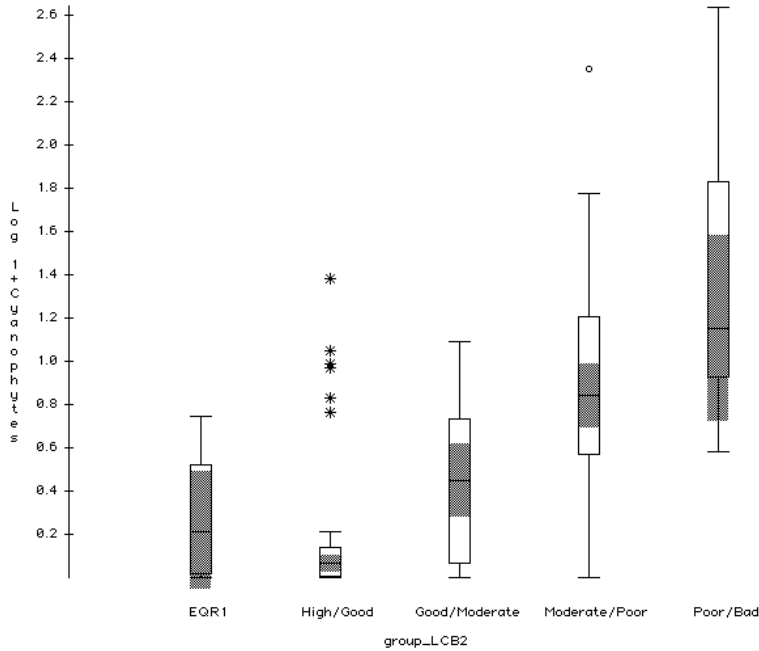

Figure D.7 Log Cyanophytes+1 for LCB2 lakes occurring within ± 0.25 of proposed common metric class boundaries.

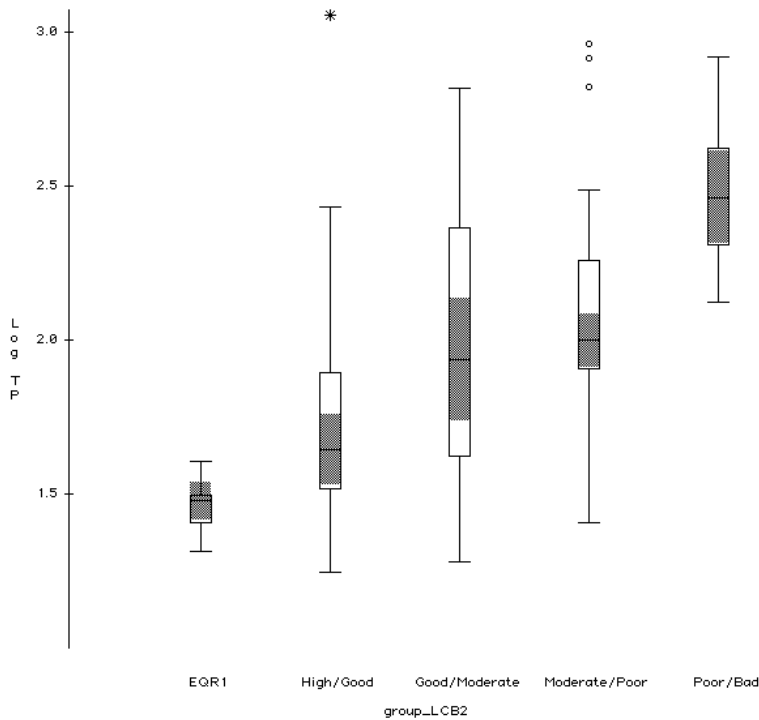

Figure D.8 Box plot of Log TP for LCB2 lakes occurring within ± 0.25 of proposed common metric class boundaries.

A description of the associated environmental conditions is also required by the guidance, specifically for the good/moderate boundary. A box plot of TP by boundary group shows an increase in TP across the boundaries (Figure D.8). Table D.6 and Table D.7 provide summary statistics of TP and chlorophyll *a* respectively.

Table D.6 Summary statistics of TP ug/l for LCB2 boundary groups (boundary ± 0.25 class).

Group	Count	Mean	Median	StdDev	Lower 25%tile	Upper 75%tile
EQR1	8	18.5	23.0	16.3	0.0	30.6
High/Good	29	98.0	44.3	207.6	32.3	77.3
Good/Moderate	40	135.8	75.3	166.4	36.8	152.0
Moderate/Poor	46	152.3	98.3	190.2	62.6	171.3
Poor/Bad	11	344.7	292.2	198.2	207.3	419.4

Table D.7 Summary statistics of Chlorophyll *a* ug/l for LCB2 boundary groups (boundary ± 0.25 class)

Group	Count	Mean	Median	StdDev	Lower 25%tile	Upper 75%tile
EQR1	8	10.0	7.6	7.4	6.6	8.7
High/Good	29	14.9	12.1	8.8	8.7	19.6
Good/Moderate	40	25.8	22.4	11.1	19.9	30.5
Moderate/Poor	46	66.4	55.5	42.8	39.3	76.5
Poor/Bad	11	151.6	167.8	50.4	112.1	192.5

Indicator species analysis was carried out for LCB2 lakes on 264 taxa. The requirements of intercalibration include a description of reference (or alternative benchmark) as well as a description of the good/moderate boundary. The indicator values produced provide a composite value of abundance and frequency of occurrence for each taxa at each boundary (Table D.8). This should provide an objective description of the changes in phytoplankton across the proposed boundaries for LCB2.

LCB2 'benchmark' description (EQR of common metric equal to 0.857 ± 0.25 class)

Owing to the low number of lakes (8) that had a of common metric value equal to 1 ± 0.25 class and the acknowledged difficulty of finding sufficient lakes representative of reference condition for LCB2 it was decided to provide a description of the H/G boundary as a benchmark. Although, as 'continuous benchmarking' was used, the indicator values in Table D.8 could be used to provide a description for all boundaries.

Twelve taxa had had a maximum indicator value (IV) recorded in the H/G group that was greater than 10: Chlamydomonas, Ankyra, Plagioselmis, Chlorococcales, Actinastrum, Staurastrum1, Monoraphidium1, Discostella, Kephyrion, Raphidocelis, Merismopedia1, Tabellaria (Table D.8). Thirty-six other taxa had their maximum IV recoded in the H/G group but were weaker indicators (Table D.8). Four taxa that were highly indicative of the poor/bad boundary had an IV of 0 in the H/G group: Scenedesmus2, Planktothrix arg.grp,

Limnotherix and Pseudanabaena. Despite these taxa frequently occurring in the H/G or EQR1 groups their relative abundance was notably low, therefore yielding an IV of 0.

LCB2 Good/Moderate boundary

For the good/moderate boundary seventeen taxa had a maximum indicator value (IV) recorded that was greater than 10: Peridinium, Trachelomonas, Cryptomonas, Lagerheimia, Ceratium, Ulnaria, Euglena, Asterionella, Cyclotella¹, Phacus, Tetrastrum³, Monoraphidium², Aulacoseira gran.grp, Kirchneriella, Urosolenia, Goniochloris and Chrysococcus. Sixty-nine other taxa had their maximum IV recoded in the good/moderate group but were weaker indicators (Table D.8).

Taxa characteristic of other boundaries may be seen in Table D.8. Taxa are grouped from EQR1 to poor/bad depending on what class they were most indicative of (had their maximum IV in). Within each group, taxa are ranked by IV.

References

- Dufrene, M. & Legendre, P. (1997) Species assemblages and indicator species: the need for a flexible asymmetrical approach. *Ecological Monographs*, **67**, 345-366.
- McCune, B. and Mefford, M. J., 1999. PC-ORD. *Multivariate Analysis Ecological Data*. Version 4. MjM Software Design, Gleneden Beach, Oregon, USA.

Intercalibration of biological elements for lake water bodies

Table D.8 Results of indicator species analysis carried out for LCB2 lakes. Groups were defined by lakes occurring within ± 0.25 of proposed common metric class boundaries for EQR 1, High/Good, Good/Moderate, Moderate/Poor, Poor/Bad. Taxa are grouped from EQR1 to poor/bad depending on what class they were most indicative of (had their maximum IV in). Within each group taxa are ranked by IV. A horizontal line indicates the transition between groups.

	Relative abundance					Relative frequency					Indicator values				
	EQR 1	H/G	G/M	M/P	P/B	EQR 1	H/G	G/M	M/P	P/B	EQR 1	H/G	G/M	M/P	P/B
Monoraphidium3	74	10	0	10	6	63	55	50	50	55	46	6	0	5	3
Botryococcus	95	1	2	2	0	38	10	8	7	0	36	0	0	0	0
Closterium	50	3	9	3	35	63	59	60	41	18	31	2	5	1	6
Dinobryon	47	40	11	2	0	63	55	43	17	0	29	22	5	0	0
Uroglena	69	1	23	7	0	38	14	5	4	0	26	0	1	0	0
Quadrigula	66	3	22	9	0	38	3	5	2	0	25	0	1	0	0
Microcystis1	64	5	17	13	0	38	3	13	2	0	24	0	2	0	0
Mallomonas	49	34	8	9	0	38	41	33	22	0	18	14	3	2	0
Gloeocapsa	100	0	0	0	0	13	0	0	0	0	13	0	0	0	0
Meridion	100	0	0	0	0	13	0	0	0	0	13	0	0	0	0
Geminella	100	0	0	0	0	13	0	0	0	0	13	0	0	0	0
Synechocystis	100	0	0	0	0	13	0	0	0	0	13	0	0	0	0
Aphanothece	49	8	31	11	0	25	14	18	11	0	12	1	5	1	0
Closteriopsis	99	0	0	0	1	13	0	8	9	9	12	0	0	0	0
Stichogloea	96	0	0	4	0	13	0	0	2	0	12	0	0	0	0
Lyngbya	94	1	0	5	0	13	3	0	7	0	12	0	0	0	0
Chlorophyta	31	27	42	0	0	38	17	10	0	0	12	5	4	0	0
Characium	92	8	0	0	0	13	3	0	0	0	12	0	0	0	0
Glenodinium	83	0	6	11	0	13	0	10	9	0	10	0	1	1	0

Intercalibration of biological elements for lake water bodies

	Relative abundance					Relative frequency					Indicator values				
	EQR 1	H/G	G/M	M/P	P/B	EQR 1	H/G	G/M	M/P	P/B	EQR 1	H/G	G/M	M/P	P/B
Korshikoviella	81	4	15	0	0	13	3	3	0	0	10	0	0	0	0
Ankistrodesmus	68	31	0	0	0	13	21	8	20	0	9	6	0	0	0
Radiocystis	52	0	25	23	0	13	0	8	4	0	6	0	2	1	0
Crucigeniella	44	0	32	3	20	13	3	15	4	9	6	0	5	0	2
Coenochloris	40	0	10	50	0	13	0	3	2	0	5	0	0	1	0
Chlorella	26	1	23	49	0	13	3	3	7	0	3	0	1	3	0
Chlamydomonas	2	64	10	19	6	63	52	43	28	9	1	33	4	5	1
Ankyra	0	98	2	0	0	25	24	23	4	0	0	24	0	0	0
Plagioselmis	12	29	29	22	8	75	79	68	57	36	9	23	20	12	3
Chlorococcales	1	61	10	18	10	13	34	30	26	27	0	21	3	5	3
Actinastrum	0	81	2	15	3	0	21	28	35	27	0	17	0	5	1
Staurastrum1	0	62	7	17	14	38	24	38	26	18	0	15	3	5	2
Monoraphidium1	1	85	5	9	0	25	17	25	22	0	0	15	1	2	0
Discostella	0	100	0	0	0	0	14	0	0	0	0	14	0	0	0
Kephyrion	4	74	19	3	0	38	17	23	11	0	1	13	4	0	0
Raphidocelis	0	92	3	2	3	0	14	8	4	9	0	13	0	0	0
Merismopedia1	0	62	35	3	0	25	17	18	22	9	0	11	6	1	0
Tabellaria	0	75	11	14	0	0	14	5	7	0	0	10	1	1	0
Pandorina	0	44	29	26	1	0	21	13	11	9	0	9	4	3	0
Merismopedia2	0	85	1	14	0	0	10	5	9	0	0	9	0	1	0
Melosira	0	82	6	12	0	0	10	8	4	0	0	8	0	1	0
Mougeotia	0	57	25	17	0	0	14	5	7	0	0	8	1	1	0

Intercalibration of biological elements for lake water bodies

	Relative abundance					Relative frequency					Indicator values				
	EQR 1	H/G	G/M	M/P	P/B	EQR 1	H/G	G/M	M/P	P/B	EQR 1	H/G	G/M	M/P	P/B
Chrysophyceae	0	28	61	10	0	0	28	13	4	0	0	8	8	0	0
Synura	1	31	27	42	0	13	24	8	7	0	0	7	2	3	0
Ophiocytium	0	100	0	0	0	0	7	0	0	0	0	7	0	0	0
Lepocinclis	0	99	1	0	0	0	7	3	0	0	0	7	0	0	0
Pennales	0	32	16	27	25	13	21	23	15	9	0	7	4	4	2
Cryptomonadales	0	93	7	0	0	0	7	5	0	0	0	6	0	0	0
Pseudopedinella	21	42	37	0	0	13	14	13	0	0	3	6	5	0	0
Centritractus	0	57	43	0	0	0	7	5	0	0	0	4	2	0	0
Trachydiscus	0	33	38	29	0	0	10	5	2	0	0	3	2	1	0
Willea	0	100	0	0	0	0	3	0	0	0	0	3	0	0	0
Staurodesmus	0	100	0	0	0	0	3	0	0	0	0	3	0	0	0
Synechococcus	0	100	0	0	0	0	3	5	2	0	0	3	0	0	0
Stichococcus	0	100	0	0	0	0	3	0	0	0	0	3	0	0	0
Prasinophyceae	0	100	0	0	0	0	3	0	0	0	0	3	0	0	0
Peronia	0	100	0	0	0	0	3	0	0	0	0	3	0	0	0
Hyalotheca	0	100	0	0	0	0	3	0	0	0	0	3	0	0	0
Pseudopediastrum	0	100	0	0	0	0	3	3	0	0	0	3	0	0	0
Radiococcus	0	100	0	0	0	0	3	0	0	0	0	3	0	0	0
Characiopsis	0	100	0	0	0	0	3	0	0	0	0	3	0	0	0
Gloeotrichia	0	100	0	0	0	0	3	0	0	0	0	3	0	0	0
Chrysiastrium	0	100	0	0	0	0	3	0	0	0	0	3	0	0	0
Conjugatophyceae	0	100	0	0	0	0	3	0	0	0	0	3	0	0	0

Intercalibration of biological elements for lake water bodies

	Relative abundance					Relative frequency					Indicator values				
	EQR 1	H/G	G/M	M/P	P/B	EQR 1	H/G	G/M	M/P	P/B	EQR 1	H/G	G/M	M/P	P/B
Gloeobotrys	0	100	0	0	0	0	3	0	0	0	0	3	0	0	0
Pleurotaenium	0	100	0	0	0	0	3	0	0	0	0	3	0	0	0
Xanthophyceae	0	100	0	0	0	0	3	0	0	0	0	3	0	0	0
Monomastix	0	100	0	0	0	0	3	0	0	0	0	3	0	0	0
Spermatozopsis	0	31	64	5	0	0	10	5	4	0	0	3	3	0	0
Ulotrichales	0	42	31	27	0	0	7	3	2	0	0	3	1	1	0
Achnanthes	0	41	59	0	0	0	7	3	0	0	0	3	1	0	0
Euastrum	0	57	43	0	0	0	3	3	0	0	0	2	1	0	0
Peridiniopsis	0	58	42	0	0	0	3	3	0	0	0	2	1	0	0
Pseudosphaerocystis	0	53	47	0	0	0	3	3	0	0	0	2	1	0	0
Peridinium	3	24	53	19	1	50	38	65	35	18	1	9	34	7	0
Trachelomonas	5	4	66	20	4	63	38	48	28	18	3	2	31	6	1
Cryptomonas	4	12	29	25	29	100	90	93	87	73	4	11	27	21	21
Lagerheimia	0	1	88	5	7	0	17	30	33	9	0	0	26	2	1
Ceratium	1	10	63	25	0	38	34	40	41	9	0	4	25	10	0
Ulnaria	0	3	69	28	1	25	48	35	30	18	0	1	24	9	0
Euglena	3	10	52	35	0	25	38	45	28	0	1	4	23	10	0
Asterionella	19	32	36	13	0	63	41	45	30	0	12	13	16	4	0
Cyclotella1	3	20	59	19	0	13	31	28	22	0	0	6	16	4	0
Phacus	3	1	52	43	0	38	21	30	26	0	1	0	16	11	0
Tetrastrum3	0	0	90	3	7	0	10	18	17	9	0	0	16	1	1
Monoraphidium2	0	27	63	1	8	13	31	23	20	9	0	8	14	0	1

Intercalibration of biological elements for lake water bodies

	Relative abundance					Relative frequency					Indicator values				
	EQR 1	H/G	G/M	M/P	P/B	EQR 1	H/G	G/M	M/P	P/B	EQR 1	H/G	G/M	M/P	P/B
Aulacoseira gran.grp	0	10	27	25	38	13	38	48	39	27	0	4	13	10	10
Kirchneriella	1	10	37	37	16	50	38	35	22	9	0	4	13	8	1
Urosolenia	1	1	96	3	0	13	14	13	4	0	0	0	12	0	0
Goniochloris	2	0	96	1	0	25	17	13	9	0	1	0	12	0	0
Chrysococcus	10	8	45	37	0	25	17	23	11	0	3	1	10	4	0
Cyanodictyon	1	0	97	3	0	13	0	10	7	0	0	0	10	0	0
Pseudogoniochloris	0	5	95	0	0	0	3	10	0	0	0	0	10	0	0
Carteria	0	5	94	1	0	0	7	10	4	0	0	0	9	0	0
Staurosira	0	0	89	11	0	0	10	10	11	0	0	0	9	1	0
Anabaena lem.grp	0	5	71	25	0	0	10	13	4	0	0	0	9	1	0
Skeletonema	0	2	86	11	0	0	10	10	4	0	0	0	9	0	0
Amphora	0	3	68	28	0	0	7	13	4	0	0	0	9	1	0
Tetrastrum2	0	4	51	46	0	0	10	15	4	0	0	0	8	2	0
Chrysochromulina	0	6	38	56	0	0	14	20	11	0	0	1	8	6	0
Gomphonema	0	1	98	2	0	0	3	8	2	0	0	0	7	0	0
Sphaerocystis	2	23	29	19	27	25	14	23	15	9	0	3	6	3	2
Cocconeis	3	5	86	7	0	25	3	8	7	0	1	0	6	0	0
Gyrosigma	0	4	61	35	0	0	3	10	7	0	0	0	6	2	0
Rhodomonas	0	4	82	14	0	0	7	8	4	0	0	0	6	1	0
Chroococcus	2	9	15	15	58	50	24	35	20	9	1	2	5	3	5
Cyclostephanos	0	0	95	5	0	0	0	5	2	0	0	0	5	0	0
Cymbella	1	5	94	1	0	13	14	5	2	0	0	1	5	0	0

Intercalibration of biological elements for lake water bodies

	Relative abundance					Relative frequency					Indicator values				
	EQR 1	H/G	G/M	M/P	P/B	EQR 1	H/G	G/M	M/P	P/B	EQR 1	H/G	G/M	M/P	P/B
Schroederia	0	1	92	4	3	13	14	5	13	9	0	0	5	1	0
Cymatopleura	0	7	92	1	0	0	7	5	2	0	0	0	5	0	0
Tetraëdriella	17	0	83	0	0	13	0	5	0	0	2	0	4	0	0
Oscillatoriales	0	1	78	10	11	0	7	5	2	9	0	0	4	0	1
Staurastrum2	0	3	46	17	34	0	3	8	7	9	0	0	3	1	3
Nephrodiella	0	36	64	0	0	0	7	5	0	0	0	3	3	0	0
Siderocelis	0	8	57	33	2	0	3	5	4	9	0	0	3	1	0
Planctonema	0	0	54	46	0	0	0	5	2	0	0	0	3	1	0
Tetrachlorella	0	0	100	0	0	0	0	3	0	0	0	0	3	0	0
Stauroneis	0	0	100	0	0	0	3	3	0	0	0	0	2	0	0
Koliella	0	0	99	0	0	0	14	3	4	9	0	0	2	0	0
Rhoicosphenia	0	0	100	0	0	0	0	3	0	0	0	0	3	0	0
Ulothrix	0	0	99	1	0	0	0	3	2	0	0	0	2	0	0
Eutetramorus	0	0	100	0	0	0	0	3	0	0	0	0	3	0	0
Planctococcus	0	0	100	0	0	0	0	3	0	0	0	0	3	0	0
Caloneis	0	0	100	0	0	0	0	3	0	0	0	0	3	0	0
Gloeocystis	0	0	100	0	0	0	0	3	0	0	0	0	3	0	0
Strombomonas	0	0	100	0	0	0	0	3	0	0	0	0	3	0	0
Chaetophora	0	0	100	0	0	0	0	3	0	0	0	0	3	0	0
Pseudopolyedriopsis	0	0	100	0	0	0	0	3	0	0	0	0	3	0	0
Syncrypta	0	0	100	0	0	0	0	3	0	0	0	0	3	0	0
Coronastrum	0	0	100	0	0	0	0	3	0	0	0	0	3	0	0

Intercalibration of biological elements for lake water bodies

	Relative abundance					Relative frequency					Indicator values				
	EQR 1	H/G	G/M	M/P	P/B	EQR 1	H/G	G/M	M/P	P/B	EQR 1	H/G	G/M	M/P	P/B
Rhizochrysis	0	0	100	0	0	0	0	3	0	0	0	0	3	0	0
Epithemia	0	0	100	0	0	0	0	3	0	0	0	0	3	0	0
Diploneis	0	0	100	0	0	0	0	3	0	0	0	0	3	0	0
Hippodonta	0	0	100	0	0	0	0	3	0	0	0	0	3	0	0
Karayevia	0	0	100	0	0	0	0	3	0	0	0	0	3	0	0
Kolbesia	0	0	100	0	0	0	0	3	0	0	0	0	3	0	0
Pleurosigma	0	0	100	0	0	0	0	3	0	0	0	0	3	0	0
Cyanocatena	0	0	100	0	0	0	0	3	0	0	0	0	3	0	0
Siderocystopsis	0	0	100	0	0	0	0	3	0	0	0	0	3	0	0
Placoneis	0	0	100	0	0	0	0	3	0	0	0	0	3	0	0
Gonium	0	6	94	0	0	0	3	3	0	0	0	0	2	0	0
Coenocystis	0	0	95	0	5	0	0	3	0	9	0	0	2	0	0
Eunotia	0	4	96	0	0	0	3	3	0	0	0	0	2	0	0
Gloeotila	0	3	97	0	0	0	3	3	0	0	0	0	2	0	0
Pseudodidymocystis	0	0	96	4	0	0	0	3	2	0	0	0	2	0	0
Paulschulzia	0	8	92	0	0	0	3	3	0	0	0	0	2	0	0
Dichotomococcus	0	0	92	8	0	0	0	3	2	0	0	0	2	0	0
Amphikrikos	0	7	93	0	0	0	3	3	0	0	0	0	2	0	0
Hortobagiella	0	0	92	8	0	0	0	3	2	0	0	0	2	0	0
Delphineis	0	0	93	7	0	0	0	3	2	0	0	0	2	0	0
Euglenophyceae	0	55	45	0	0	0	3	5	0	0	0	2	2	0	0
Cymatosira	0	0	87	13	0	0	0	3	2	0	0	0	2	0	0

Intercalibration of biological elements for lake water bodies

	Relative abundance					Relative frequency					Indicator values				
	EQR 1	H/G	G/M	M/P	P/B	EQR 1	H/G	G/M	M/P	P/B	EQR 1	H/G	G/M	M/P	P/B
Opephora	0	0	83	17	0	0	0	3	2	0	0	0	2	0	0
Tribonema	0	5	67	28	0	0	7	3	2	0	0	0	2	1	0
Volvox	0	0	67	33	0	0	0	3	2	0	0	0	2	1	0
Chromulina	0	2	65	33	0	0	7	3	4	0	0	0	2	1	0
Pseudokephyrion	0	38	62	0	0	0	3	3	0	0	0	1	2	0	0
Platessa	0	0	65	35	0	0	0	3	2	0	0	0	2	1	0
Monomorphina	0	40	60	0	0	0	3	3	0	0	0	1	2	0	0
Lemmermanniella	0	0	50	50	0	0	0	3	2	0	0	0	1	1	0
Pediastrum	1	9	18	59	14	50	55	63	70	36	0	5	11	41	5
Tetraedron	1	3	13	69	15	50	31	45	50	27	0	1	6	35	4
Dictyosphaerium	3	5	6	72	15	13	31	33	37	18	0	1	2	26	3
Microcystis3	1	3	4	72	20	25	14	30	35	9	0	0	1	25	2
Centrales	1	2	8	52	37	50	31	40	48	36	0	1	3	25	13
Aulacoseira it.is.grp	0	8	34	57	1	13	41	48	43	9	0	3	16	25	0
Scenedesmus3	0	1	6	46	47	38	41	50	52	18	0	0	3	24	9
Tetrasporales	3	5	10	79	2	38	21	18	30	9	1	1	2	24	0
Anabaena grp	34	2	14	46	4	63	38	48	50	36	22	1	7	23	2
Aphanocapsa	1	2	39	59	0	63	31	43	35	0	0	1	16	20	0
Planktolynbya	0	3	34	61	2	13	7	25	33	27	0	0	9	20	1
Snowella	1	13	8	75	4	25	24	20	24	18	0	3	2	18	1
Fragilaria	0	6	31	62	1	38	48	50	28	9	0	3	15	18	0
Crucigenia	0	26	26	48	0	13	24	43	35	0	0	6	11	17	0

Intercalibration of biological elements for lake water bodies

	Relative abundance					Relative frequency					Indicator values				
	EQR 1	H/G	G/M	M/P	P/B	EQR 1	H/G	G/M	M/P	P/B	EQR 1	H/G	G/M	M/P	P/B
Elakatothrix	5	9	11	75	0	50	17	23	20	0	2	2	2	15	0
Phytoplankton, unid	8	13	12	27	40	100	72	50	52	18	8	9	6	14	7
Oocystis	11	10	18	24	37	50	48	60	57	36	5	5	11	14	14
Oscillatoria	1	17	36	44	3	38	24	33	30	9	0	4	12	13	0
Trichormus	2	0	10	87	0	13	14	10	15	0	0	0	1	13	0
Cyanophyceae	6	2	9	83	0	25	14	18	15	0	1	0	2	13	0
Golenkinia	0	0	2	98	0	0	0	18	13	0	0	0	0	13	0
Scenedesmus1	1	1	9	83	6	25	17	10	15	9	0	0	1	13	1
Navicula	0	0	18	81	0	38	7	15	15	0	0	0	3	12	0
Diatoma	0	1	16	83	0	13	17	18	13	0	0	0	3	11	0
Volvocales	0	0	0	96	3	0	7	13	11	18	0	0	0	10	1
Micractinium	0	4	4	92	0	0	14	8	11	0	0	1	0	10	0
Coelosphaerium	0	24	17	59	0	13	10	15	15	0	0	2	3	9	0
Cosmarium1	9	11	15	51	15	50	14	23	17	18	5	1	3	9	3
Pteromonas	0	0	7	93	0	0	3	8	9	0	0	0	1	8	0
Treubaria	0	4	5	91	0	0	10	10	9	0	0	0	1	8	0
Chroococcales	0	30	7	47	17	0	17	15	15	27	0	5	1	7	5
Cryptophyceae	0	1	7	54	38	0	21	15	13	18	0	0	1	7	7
Cyclotella2	0	0	23	77	0	0	3	15	9	9	0	0	3	7	0
Chlorotetraedron	1	0	1	98	0	13	0	5	7	0	0	0	0	6	0
Phormidium	0	13	0	87	0	0	3	0	7	0	0	0	0	6	0
Gomphosphaeria	2	3	10	85	0	13	3	5	7	0	0	0	1	6	0

Intercalibration of biological elements for lake water bodies

	Relative abundance					Relative frequency					Indicator values				
	EQR 1	H/G	G/M	M/P	P/B	EQR 1	H/G	G/M	M/P	P/B	EQR 1	H/G	G/M	M/P	P/B
Pseudostaurastrum	0	0	9	84	7	0	0	5	7	9	0	0	0	5	1
Acanthoceras	0	0	21	79	0	0	0	3	7	0	0	0	1	5	0
Eudorina	0	4	27	70	0	0	10	8	7	0	0	0	2	5	0
Chroomonas	11	6	15	34	33	25	14	23	13	9	3	1	3	4	3
Cosmarium2	0	0	0	100	0	0	0	0	4	0	0	0	0	4	0
Cylindrospermopsis	0	0	0	100	0	0	0	0	4	0	0	0	0	4	0
Planothidium	0	0	0	100	0	0	0	0	4	0	0	0	0	4	0
Cosmarium3	0	0	3	97	0	0	0	3	4	0	0	0	0	4	0
Surirella	0	2	7	91	0	0	7	8	4	0	0	0	1	4	0
Phacotus	0	0	17	83	0	0	0	3	4	0	0	0	0	4	0
Bitrichia	12	4	0	84	0	13	3	0	4	0	2	0	0	4	0
Didymocystis	3	0	25	72	0	13	0	3	4	0	0	0	1	3	0
Merismopedia	0	25	11	64	0	0	7	5	4	0	0	2	1	3	0
Chlamydocapsa	0	1	0	99	0	0	3	0	2	0	0	0	0	2	0
Jaaginema	0	0	0	100	0	0	0	0	2	0	0	0	0	2	0
Keratococcus	0	0	0	100	0	0	0	0	2	0	0	0	0	2	0
Spirulina	0	0	0	100	0	0	0	3	2	0	0	0	0	2	0
Pseudoquadrigula	0	0	0	100	0	0	0	0	2	0	0	0	0	2	0
Planktothrix grp	0	0	0	100	0	0	0	0	2	0	0	0	0	2	0
Binuclearia	0	0	0	100	0	0	0	0	2	0	0	0	0	2	0
Tetraselmis	0	0	0	100	0	0	0	0	2	0	0	0	0	2	0
Chlorogonium	0	0	0	100	0	0	0	0	2	0	0	0	0	2	0

Intercalibration of biological elements for lake water bodies

	Relative abundance					Relative frequency					Indicator values				
	EQR 1	H/G	G/M	M/P	P/B	EQR 1	H/G	G/M	M/P	P/B	EQR 1	H/G	G/M	M/P	P/B
Cyanogranis	0	28	21	51	0	0	3	3	4	0	0	1	1	2	0
Spondylosium	0	0	0	100	0	0	0	0	2	0	0	0	0	2	0
Chaetoceros	0	0	0	100	0	0	0	0	2	0	0	0	0	2	0
Colacium	0	0	0	100	0	0	0	0	2	0	0	0	0	2	0
Pseudotetrastrum	0	0	0	100	0	0	0	0	2	0	0	0	0	2	0
Lobocystis	0	0	0	100	0	0	0	0	2	0	0	0	0	2	0
Komarekia	0	0	0	100	0	0	0	0	2	0	0	0	0	2	0
Entomoneis	0	0	0	100	0	0	0	0	2	0	0	0	0	2	0
Eucapsis	0	0	0	100	0	0	0	0	2	0	0	0	0	2	0
Lobomonas	0	0	0	100	0	0	0	0	2	0	0	0	0	2	0
Bacillaria	0	0	0	100	0	0	0	0	2	0	0	0	0	2	0
Tabularia	0	0	0	100	0	0	0	0	2	0	0	0	0	2	0
Chlorolobion	0	0	0	100	0	0	0	0	2	0	0	0	0	2	0
Didymogenes	0	0	0	100	0	0	0	0	2	0	0	0	0	2	0
Cylindrotheca	0	0	4	96	0	0	0	5	2	0	0	0	0	2	0
Nephrochlamys	0	1	0	99	0	0	7	0	2	0	0	0	0	2	0
Dinophyceae	0	1	4	95	0	0	3	5	2	0	0	0	0	2	0
Staurosirella	0	0	1	99	0	0	0	3	2	0	0	0	0	2	0
Catena	0	0	1	99	0	0	0	3	2	0	0	0	0	2	0
Nephrocytium	6	2	2	91	0	25	3	3	2	0	2	0	0	2	0
Geitlerinema	0	0	10	90	0	0	0	3	2	0	0	0	0	2	0
Tryblionella	0	0	14	86	0	0	0	3	2	0	0	0	0	2	0

Intercalibration of biological elements for lake water bodies

	Relative abundance					Relative frequency					Indicator values				
	EQR 1	H/G	G/M	M/P	P/B	EQR 1	H/G	G/M	M/P	P/B	EQR 1	H/G	G/M	M/P	P/B
Franceia	0	0	43	57	0	0	0	3	2	0	0	0	1	1	0
Scenedesmus2	1	0	4	25	71	75	66	83	83	91	0	0	3	20	64
Planktothrix arg.grp	0	0	1	12	87	13	14	28	35	55	0	0	0	4	47
Limnothrix	0	0	2	20	78	13	0	13	20	55	0	0	0	4	43
Pseudanabaena	0	0	3	12	84	25	31	33	41	45	0	0	1	5	38
Anabaena flos.grp	0	5	1	25	70	25	24	43	37	55	0	1	0	9	38
Romeria	0	0	0	7	93	0	0	0	7	27	0	0	0	0	25
Anabaenopsis	0	0	0	8	92	0	0	0	4	27	0	0	0	0	25
Diplochlois	0	0	0	8	91	0	3	3	7	27	0	0	0	1	25
Microcystis2	0	0	3	9	87	13	17	40	41	27	0	0	1	4	24
Nitzschia	0	2	8	30	61	25	48	43	54	36	0	1	3	16	22
Coelastrum	0	17	4	15	64	25	34	52	39	27	0	6	2	6	17
Ochromonas	0	0	2	6	92	38	14	8	9	18	0	0	0	1	17
Aphanizomenon	0	1	1	8	89	13	34	58	74	18	0	0	0	6	16
Stephanodiscus	0	3	5	7	84	0	24	35	33	18	0	1	2	2	15
Woronichinia	0	0	28	11	61	0	10	15	15	18	0	0	4	2	11
Coelomoron	0	0	0	0	100	0	0	0	0	9	0	0	0	0	9
Actinocyclus	0	0	3	1	97	0	0	8	2	9	0	0	0	0	9
Peridinales	0	1	1	2	96	0	7	3	9	9	0	0	0	0	9
Aulacoseira alp.grp	0	1	2	7	90	0	3	3	4	9	0	0	0	0	8
Tetrastrum1	0	2	4	15	79	0	10	10	9	9	0	0	0	1	7
Planktosphaeria	0	0	30	0	70	0	0	3	0	9	0	0	1	0	6

Intercalibration of biological elements for lake water bodies

	Relative abundance					Relative frequency					Indicator values				
	EQR 1	H/G	G/M	M/P	P/B	EQR 1	H/G	G/M	M/P	P/B	EQR 1	H/G	G/M	M/P	P/B
Nostocales	0	1	2	30	67	0	3	3	4	9	0	0	0	1	6
Quadricoccus	0	0	0	40	60	0	0	0	2	9	0	0	0	1	5
Gymnodinium	9	3	12	25	51	25	21	15	17	9	2	1	2	4	5

E. Common metric: Development and standardization

Background

Intercalibration options

To intercalibrate the phytoplankton metrics the following options are available:

1. Option 2. Comparison of Member State (MS) EQR with a WISER common metric EQR using only water bodies from that MS;
2. Option 3a (i). Comparison of MS EQR with a WISER common metric EQR using all water bodies where it is appropriate to apply the MS method to a different MS water body;
3. Option 3a (ii). Use ME EQRs to create a pseudo common metric by averaging and use this to compare MS method using all water bodies where it is appropriate to apply the MS method to a different MS water body.

The GIG initially intended to explore all of the above options for the intercalibration of CBGIG phytoplankton:

- However, the second and third methods require considerable more work as “standardisation” of the national metrics is required in addition to the common metric;
- Option 2 also has the advantage that a MS method is only applied to its own water bodies and thus the national method is tested on conditions that it was designed to assess, a more appropriate validation of the method.
- The only exception to this was where countries had too few lakes to provide a valid relationship with the common metric, or the relationship was poor. In these few cases Option 3a (i) was used, the only difference in approach being that the national method was applied to appropriate other countries data in addition to their own.

Common metric - summary

After testing various approaches the GIG agreed to use a common metric which was the average of a normalised Chlorophyll a EQR and the Plankton Trophic Index (PTI) EQR, developed by WISER (Phillips *et al.* 2010). Consideration was given to using additional metrics, such as the number or the proportion of cyanobacteria and evenness. We found that the evenness metric was not sufficiently responsive in CBGIG lakes and as testing various combinations of cyanobacteria metrics did not improve the relationship between the combined common metric and pressure measured by mean total phosphorus, we did not include these additional metrics. A flow diagram summarising the approach and further details of the methods are described below.

Benchmark standardisation – removal of bio-geographical differences

The intercalibration guidance stresses the importance of checking for bio-geographical differences through the use of common reference or benchmark sites. In the CBGIG we

have too few reference sites to make this process robust and thus we would need to use benchmark sites. However, it was not possible to identify an appropriate pressure range of benchmark sites which would include all countries over a sufficiently small range of pressures (Figure E.1). Thus the GIG used an alternative approach (Continuous Benchmarking) which we feel is more reliable. This method compares the response of the metrics over the whole pressure gradient and allows a country specific adjustment to be made without the need to identify a benchmark range which is sufficiently narrow to act as a benchmark, but is broad enough to include sufficient sites from all countries. The approach also has the advantage that it quantifies the type of pressure response relationship which dictates whether country adjustments need to be allowed for by subtraction or division (Birk *et al.* 2011).

For phytoplankton, national methods and the common metric are a multi-metric with a final EQR derived from various forms of weighted averaging. Where national methods were applied to other countries lakes standardisation was carried out on the final national EQR. For the common metric, standardisation of the PTI metric was found to be sufficient to remove bio-geographical differences between countries.

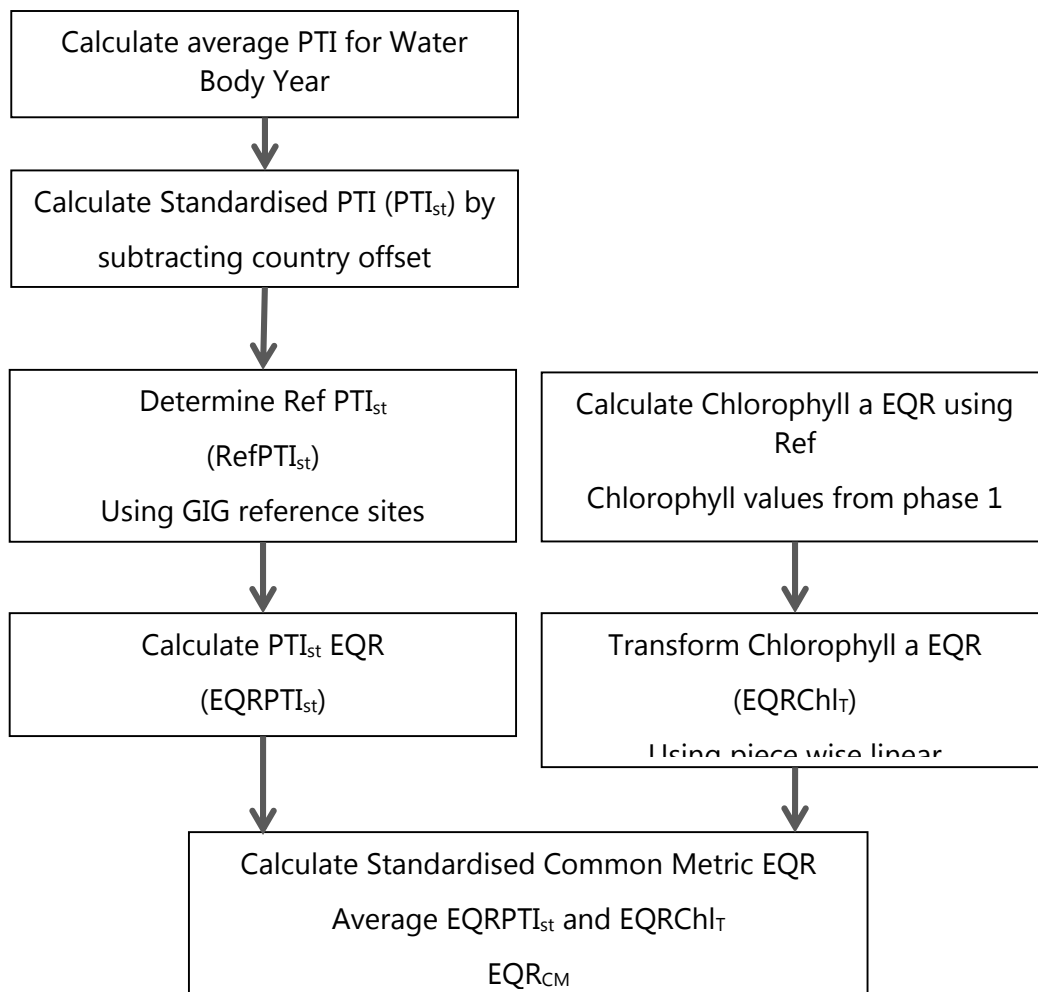

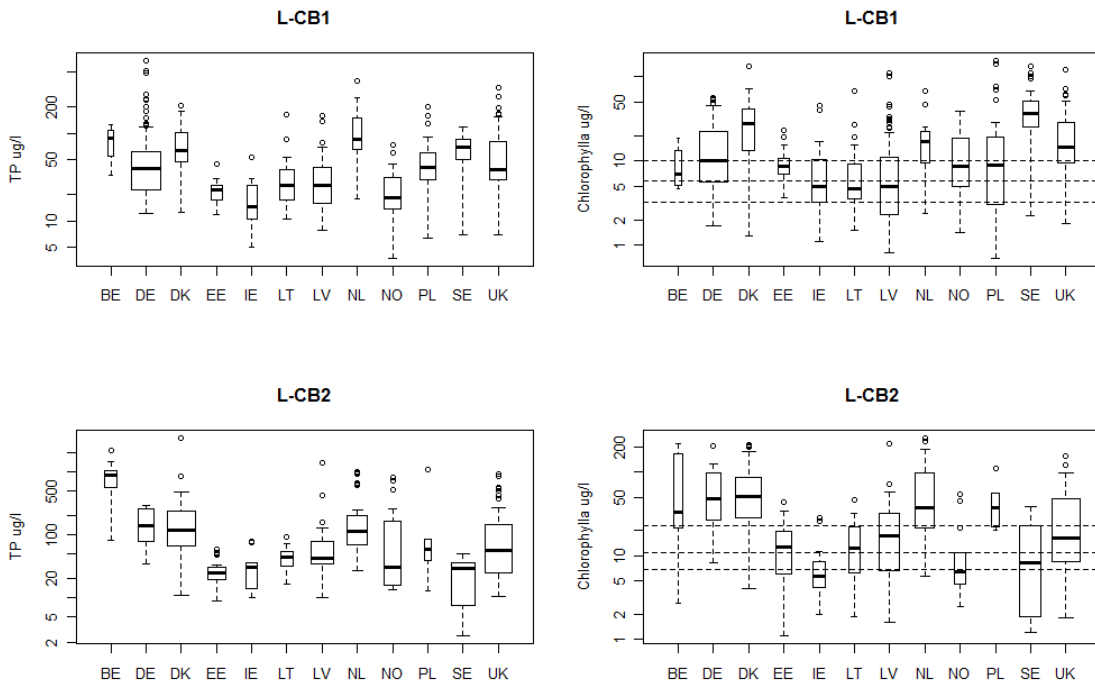

Figure E.1 Range of total phosphorus and chlorophyll a growing season mean values for LCB1 and LCB2 lakes. (Horizontal lines mark reference, high good and good moderate boundary values for chlorophyll a)

Common Metric – development and application

Chlorophyll a common metric (normalised)

Chlorophyll a EQR values were calculated using equation 1, the approach agreed in the phase 1 IC process

$$EQR_{Chl} = \frac{Chl_{Ref}}{Chl} \quad (1)$$

Where:

Chl = observed mean chlorophyll for the growing season (March – October)

Chl_{Ref} = reference chlorophyll

Reference chlorophyll values and EQR boundaries for high good and good moderate were those agreed in the phase 1 decision and specified in the technical report (Poikane 2010). As the relationship between total phosphorus and the chlorophyll EQR calculated in this way is not linear, the EQR was transformed so that boundaries were 0.8, 0.6, 0.4, 0.2 using piece-wise linear transformations (equation 2). To do this it was necessary to make assumptions about the moderate/poor and poor/bad boundaries, which were taken to be factors of 0.5 and 0.25 the agreed Good Moderate boundaries (Table E.1).

$$EQR_T = (EQR_{NT} - LB_{NT}) / (UB_{NT} - LB_{NT}) \times (UB_T - LB_T) + LB_T \quad (2)$$

Where

EQR_T = Transformed EQR (0.8, 0.6, 0.4, 0.2)

EQR_{NT} = Untransformed EQR (calculated from Equation 1)

UB_{NT} = Upper boundary of the untransformed EQR

LB_{NT} = Lower boundary of the untransformed EQR

UB_T = Upper boundary of the transformed EQR

LB_T = Lower boundary of the transformed EQR

Note that $(UB_T - LB_T)$ simplifies to 0.2

It was assumed that the UB_T for High status was 1.00

Calculations were done in a spreadsheet using lookup tables for each GIG type.

Table E.1 Reference chlorophyll a and EQR boundaries used for the chlorophyll a common metric.

Lake Type	Ref Chl a	HG EQR	GM EQR	MP EQR	PB EQR
L-CB1	3.2	0.55	0.32	0.16	0.08
L-CB2	6.8	0.63	0.30	0.15	0.08

Standardisation of Chlorophyll a metric

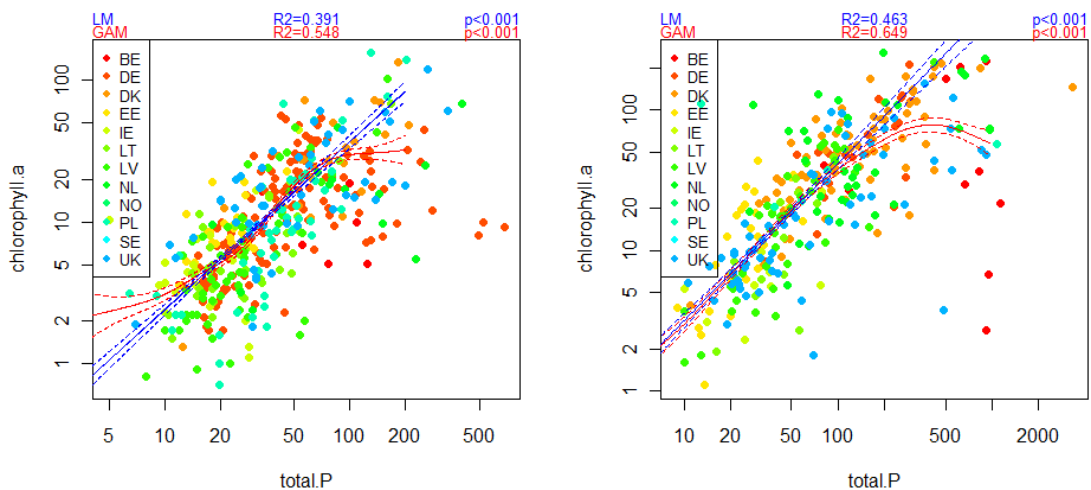

Figure E.2 Relationship between mean growing season total phosphorus and chlorophyll a for a) L-CB1 lakes and b) L-CB2 lakes, points identified by country. Red line GAM model fitted to data, blue line linear model fitted to data within linear region ($10-50 \mu\text{gTP.l}^{-1}$ for LCB1 and $10-100 \mu\text{gTP.l}^{-1}$ for LCB2)

Benchmark standardisation was not applied to the chlorophyll metric as there was no evidence that there is a significant country effect (Figure E.2). GAM models (Wood 2006) demonstrated that the relationship between log transformed chlorophyll a and total phosphorus is linear in the range of 10-60 µgP l⁻¹ and 10-100 µgP l⁻¹ for LCB1 and LCB2 lakes respectively. Linear models for chlorophyll v total phosphorus applied to these ranges, with country as a factor showed no significant effect of country for either LCB1 or LCB2 lakes

Development of WISER common metric. Calculation of a Plankton Trophic Index (PTI)

Following proposals in the draft WISER report (Phillips *et al.* 2010) a Plankton Trophic Index value (PTI) has been used to represent the taxonomic component of the phytoplankton. This was calculated using equation 3

$$PTI = \frac{\sum_{j=1}^n a_j s_j}{\sum_{j=1}^n a_j} \quad (3)$$

Where:

a_j = proportion of j th taxon in the sample

s_j = optimum of j th taxon in the sample, (derived from axis 1 of a CCA constrained by logTP)

The WISER metric was developed using summer data (July-September) so the metric is only applicable to samples from this time window. Sample PTI scores are calculated, then averaged for each Water Body Year, from which an EQR is determined using equation 4

$$EQR_{PTI} = \left(\frac{PTI_{Obs} - PTI_{Max}}{PTI_{Ref} - PTI_{Max}} \right) \quad (4)$$

Where:

PTI_{Obs} = mean sample PTI for each lake year

PTI_{Max} = Maximum PTI score for type, the upper (worst) anchor.

PTI_{Ref} = Expected or reference PTI for type, the lower (best) anchor

Table E.2 Country Offset values (random effects of mixed model intercepts, see below for details) which are subtracted from PTI for clear water high alkalinity lakes from CB and NGIGs

Country	Random Effect (County Offset)
BE	0.006
DE	0.143

DK	-0.107
EE	-0.154
IE	-0.019
LT	0.142
LV	0.102
NL	0.213
NO	-0.425
PL	0.175
SE	-0.100
UK	0.026

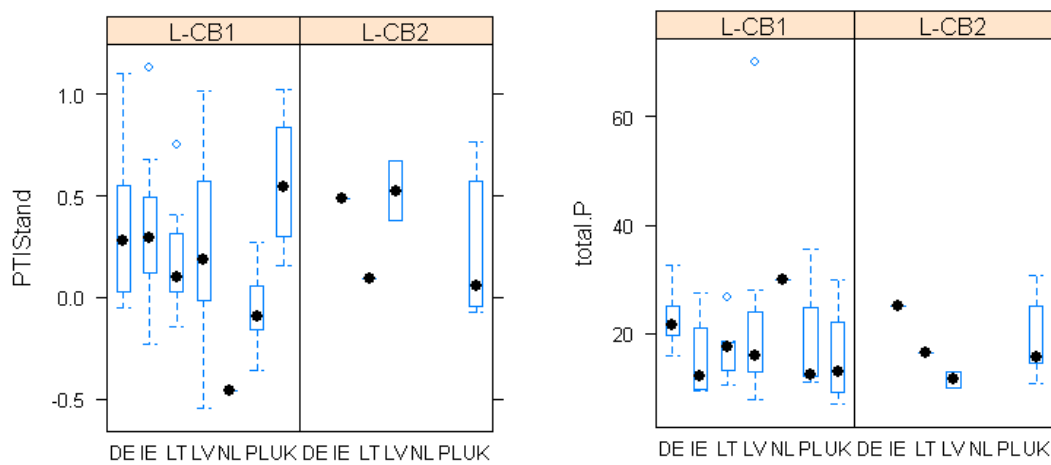

Figure E.3 Distribution of a) standardised PTI and b) total P in reference sites by country and lake type.

Prior to converting PTI values to an EQR a country specific correction (Table E.2) was subtracted from the PTI_{Obs} value to allow for country specific differences in the PTI pressure response. Type specific standardised PTI_{Ref} values¹³ were based on the median values of the standardised PTI for all available GIG reference years (Table E.3, Figure E.3).

The value of PTI_{Max} was taken as 2.2. It should be noted that this upper anchor value influences the scale of the EQRs. It needs to be greater than the maximum observed PTI to avoid negative EQRs, but to provide a reasonable range of EQRs it needs to be less than the theoretical maximum value which would be the highest taxon optima (s_j). For L-CB1 and L-CB2 lakes a value of 2.2 has been used¹⁴.

Table E.3 Distribution of Standardised PTI values for Reference Lakes

Type	Lake Years	Median PTI_{st}	Median Total P (ug/l)
------	------------	-------------------	-----------------------

¹³ note the PTI Ref value is not critical as it only serves to convert the PTI to an EQR and thus to an independent common metric scale. No attempt to set boundaries is made and thus the selection of the specific reference value is not critical to subsequent comparisons

¹⁴ This was similar to the incremental value used when the first NGIG lake type was tested (L-N2a)

L-CB1	58	0.201	18
L-CB2	10	0.259	16

Taxa Optima used to calculate PTI

The draft WISER report provided sets of genus optima derived from an analysis of the full data set and for various subsets derived from different GIGs. For CBGIG optima derived from the Northern and Central Baltic GIGs were used (Table E.7). These optima were derived from the 1st axis of a CCA ordination constrained by Log TP using the vegan package in R (Oksanen *et al.* 2010). At a WISER project board meeting some concerns were raised that some genera covered a wide range of nutrient conditions and that this could limit the usefulness of the metric. To explore this an additional series of ordinations were performed using species level data. As time was limited this analysis only used NGIG and CBGIG data and as for the previous work the CCA ordination was constrained by Log TP. The sample PTIs derived from both the species and generic optima were then compared with TP and Chl, using both linear and GAM models. As the species optima were only marginally better than those using the generic values GIG members agreed that in general species optima were less appropriate for use as a common metric. However it was felt that some some genera could be split into groups. Data were tabulated and where species optima for a given genus had a large range, and the numbers of samples used to generate the optima were sufficient, the genera were split into sub-groups. The following genera were split, *Anabeana*, *Aulacosira*, *Cosmarium*, *Cyclotella*, *Merismopedia*, *Mycrocystis*, *Monoraphidium*, *Planktothrix*, *Scendesmus*, *Staurastrum* and *Tetrastrum*. Each sub-group was then allocated an optima based on the weighted average of the species optima within the sub-group, the weight being the number of records for each species in the sub-group (Table E.8).

Finally all of the taxa listed in the WISER database, which were sufficiently common to be included in the analysis were allocated a generic or generic group optima (Available as an Excel file

NGIG_CBGIG_WISER_Optima.xls). This allows sample PTIs to be calculated quickly without the need to combine taxa at generic level.

Relationship between WISER common metric and Pressure

The relationship with PTI and TP for all lakes allocated to an alkalinity type in N and CB gigs is shown in Figure E.4. GAM models demonstrated that alkalinity type was the most significant typological factor influencing this relationship (Phillips *et al.* 2010). In the NGIG, where low alkalinity lakes dominate it was very clear that PTI values differed between countries independently of total phosphorus. For high alkalinity lakes, adding country as a factor to the GAM models increases the R² from 0.368 to 0.496, decreasing AIC from 984.38 to 812.58, suggests similar significant country effects. As was found for low alkalinity lakes the lakes from Norway have a much lower PTI than those in NL, DE, PL and to a lesser extent the UK (see coefficients Table E.4). This illustrates the need to make allowances for what are likely to be bio-geographical (climatic?) differences that are country specific and not explained by the GIG typology.

For high alkalinity lakes, the dominant lake type in CBGIG, the GAM models suggest that there is a linear relationship between PTI and the log of total phosphorus when concentration is between 5 and 100 $\mu\text{g/l}$. Linear mixed models were thus used to explore the effect of different categorical factors in this linear relationship. Alkalinity type was found to be the most significant factor influencing both slope and intercepts of the relationship (Figure E.5 and Figure E.6).

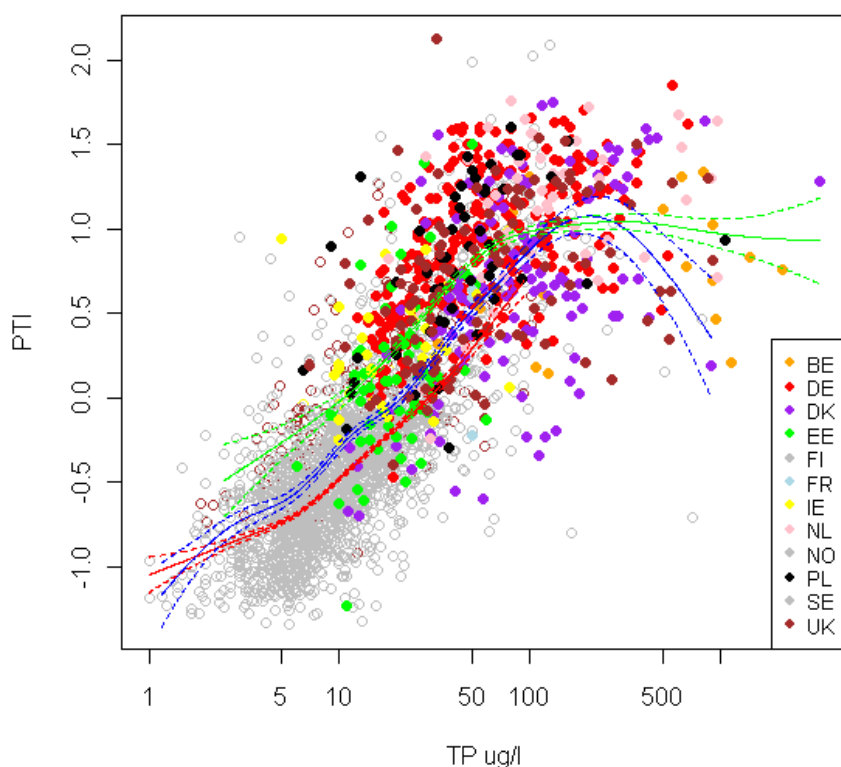

Figure E.4 Relationship between mean annual TP and PTI for lakes in N and CB gigs. Lines show GAM models fitted to alkalinity types (Red = Low Alkalinity, Blue = Moderate Alkalinity, Green = High Alkalinity). CBGIG lakes are coloured by country, NGIG lakes are shown as grey circles for information.

Table E.4 Parametric coefficients for GAM model $PTI = Country(z2) + s(LogTP)$. $R^2 = 0.496$. (R^2 for model without country as a factor is 0.368)

	Coefficient Estimate	Std. Error	T	P value	Significance
Intercept	0.459	0.103	4.463	0.0000	***
z2DE	0.397	0.106	3.737	0.0002	***
z2DK	0.072	0.110	0.656	0.5118	
z2EE	0.046	0.121	0.382	0.7024	
z2IE	0.164	0.130	1.261	0.2078	
z2NL	0.448	0.115	3.880	0.0001	***

z2NO	-0.290	0.115	-2.519	0.0120	*
z2PL	0.370	0.118	3.144	0.0017	**
z2SE	0.109	0.121	0.901	0.3677	
z2UK	0.211	0.110	1.927	0.0544	.

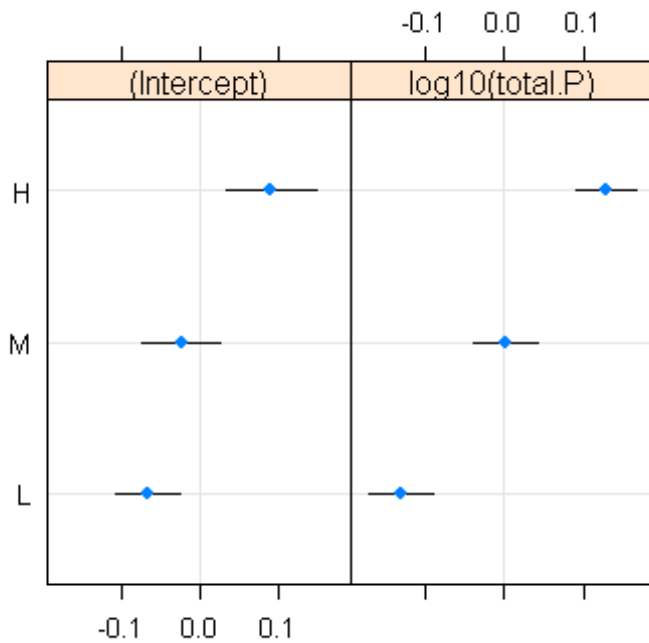

Figure E.5 values for slope and intercept of linear models of PTI v logTP with alkalinity type high (H), moderate (M) and low (L) alkalinity lakes as a random factor. Lines show confidence limits of the coefficients.

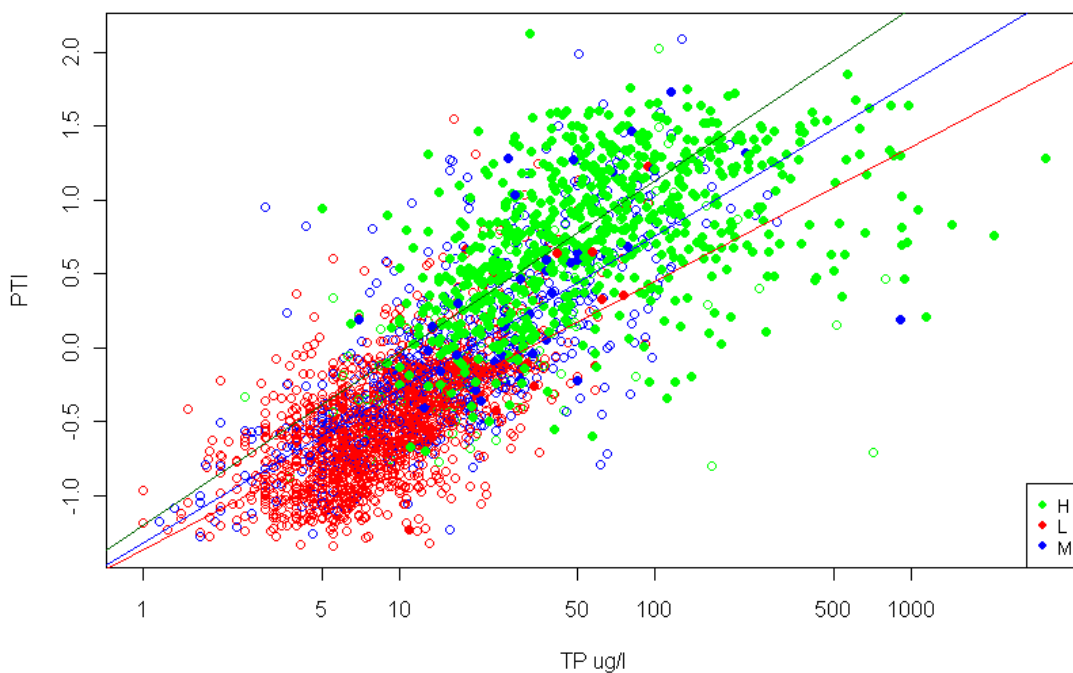

Figure E.6 Relationship between mean growing season TP and PTI, linear models fitted to high (H), moderate (M) and low (L) alkalinity lake types in NGIG and CBGIG. Open circles NGIG lakes, closed circles CBGIG lakes

Standardisation to remove country effects

All high alkalinity lakes where TP was within the range of 5-100 μl^{-1} from NGIG and CBGIG were selected and mixed linear models (Bates *et al.* 2011) were fitted with a) country and b) mean depth as random factors influencing slope and intercept. The results show that for high alkalinity lakes the effect of country had no effect on the slope of the relationship of PTI with log TP, but a significant effect on the intercepts (Figure E.8a). There was no significant effect of depth (Figure E.8b), confirming the conclusion that alkalinity is the most important factor influencing the relationship with pressure (Phillips *et al.* 2010). The resulting linear models for each country are shown in Figure E.7, together with the fit independent of country (dotted line).

The random effects due to country produced by the linear mixed model provide country offset values (Table E.2) were subtracted from the PTI values of each country to produce a standardised PTI metric. This is similar to the proposed standardisation procedure detailed in the intercalibration guidance manual, where it is proposed that the median of PTI values or EQRs for reference or benchmark sites is used (Birk *et al.* 2011). By using country specific relationships between PTI and a pressure metric, such as total phosphorus, a more robust offset can be calculated as all the data are taken into consideration, rather than reliance on a small number of lake year values for reference or benchmark sites.

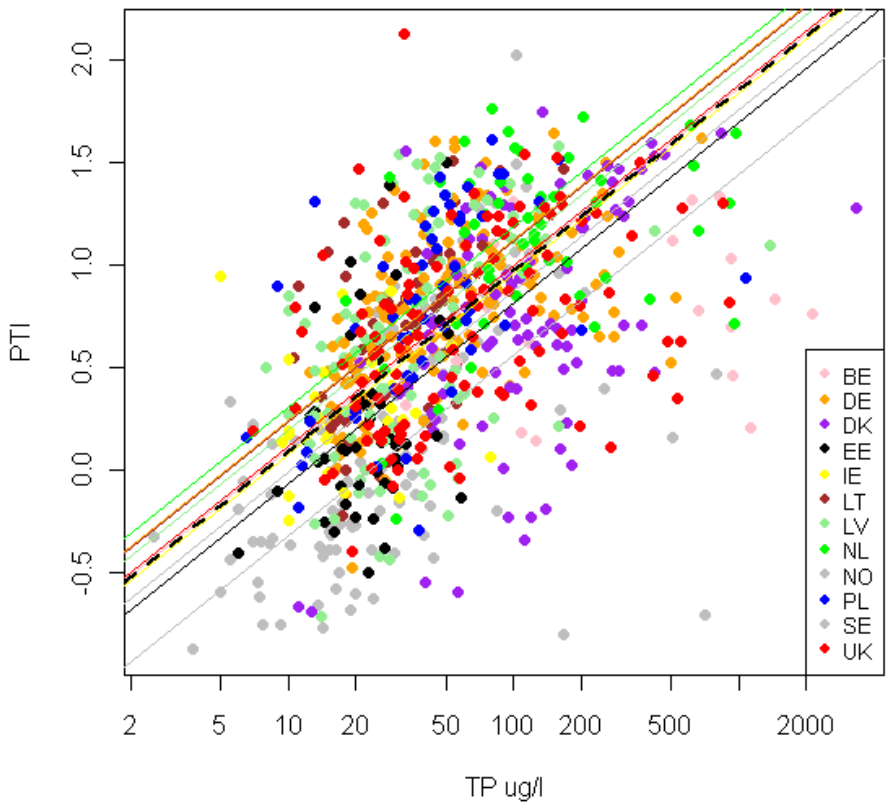

Figure E.7 Relationship between PTI and total phosphorus showing linear models fitted with Country as a random factor influencing intercept. Dotted line shows average model without country as a factor.

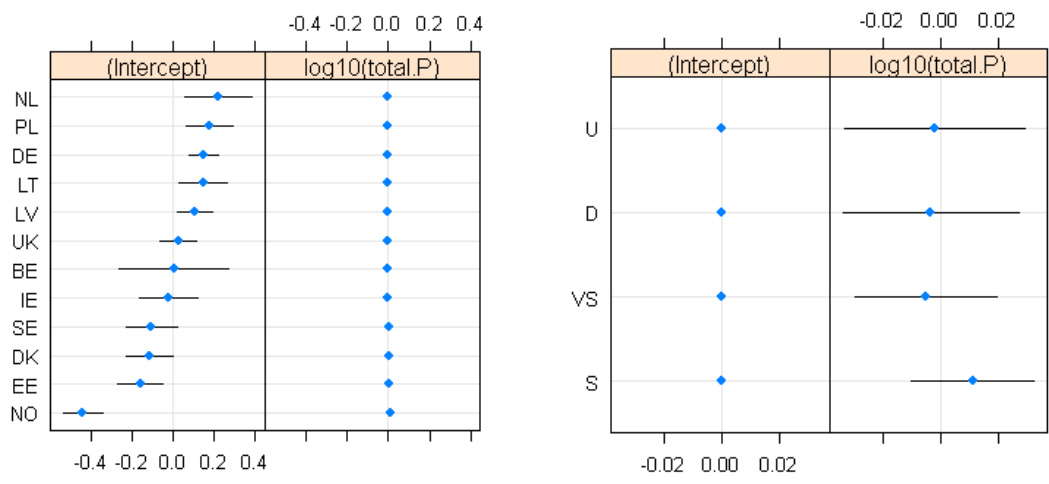

Figure E.8 values for slope and intercept of linear models of PTI v logTP with a) country and b) depth as a random factor, lines are standard errors of the coefficients.

Use of Evenness and Cyanobacteria as part of a common metric

Consideration was given to including both total biomass and the biomass of cyanobacteria within the common metric. The use of total biomass was rejected as it is correlated with chlorophyll a (Pearson $r = 0.717$) but as several CBGIG national methods use either the biovolume of cyanobacteria or the proportion of cyanobacteria a metric for cyanobacteria was considered.

The distribution of the total biovolume of cyanobacteria in reference and impacted sites is shown in Table E.5. Although there are much lower value in reference lakes, there is a very wide range of values from impacted lakes which makes calculating an EQR difficult. To test the potential use of this metric and EQR was calculated (equation 5) using a Reference value of 0.06 and an upper anchor of 50. This upper anchor value was chosen as a compromise between a value that would not produce negative EQRs and one that was low enough to provide a reasonable range of EQR values. In the subsequent analysis negative EQRs and these were set to a value of 0.

$$EQR_{Cyan} = \left(\frac{CyanBM_{Obs} - 50}{0.06 - 50} \right) \quad (5)$$

Table E.5 Distribution of the biomass of cyanobacteria in Reference and all lakes for CBGIG

Type	Reference			Non Reference Lakes	
	Median	Range	Median	99 th percentile	Range
L-CB1	0.063	0.000 – 9.679	0.498	37.5	0.00 – 79.14
L-CB2	0.032	0.001 – 0.609	0.903	77.1	0.00 - 437.58
L-CB1 & L-CB2	0.060	0.000 – 9.679	0.400	57.0	0.00 - 437.58

Combination of Chlorophyll and PTI EQR values to form a single common metric

A linear model relating the transformed Chlorophyll EQR, the standardised PTI EQR and the Cyanobacteria EQR to Log TP was used to evaluate the value of including the Cyanobacteria EQR in a common metric. The resulting coefficients (Table E.6) suggest that combining the chlorophyll and PTI EQRs improves the relationship with log TP but that there is no additional variation explained by adding an EQR representing the biomass of cyanobacteria. This is probably because the PTI EQR is correlated with cyanobacteria biomass (Figure E.10), as these taxa almost always have high PTI optima values.

Table E.6 Multiple linear model relating LogTP to transformed Chlorophyll EQR, the standardised PTI EQR and the Cyanobacteria EQR. $R^2 = 0.46$ $p < 0.001$

	Estimate	Std Error	T value	P
--	----------	-----------	---------	---

Intercept	2.037	0.068	30.011	<0.001
PTIEQRst	-0.351	0.041	-8.47	<0.001
ChIEQRN	-0.292	0.020	-14.53	<0.001
CyanBMEQR	-0.026	0.076	-0.346	0.73

Given these results the final CBGIG common metric was the average of the transformed chlorophyll EQR values and the standardised PTI EQR. This produced a metric which has a significantly better relationship with pressure than either the Chlorophyll or PTI EQRs, with an R2 value of 0.46 ($p < 0.001$) for a linear model (Figure E.9). The final common metric can have values that are greater than 1.00. The majority of MS in CBGIG truncate their national metrics to a value of 1.00, To ensure comparability the common metric was also truncated prior to calculation of relationship with the national metrics¹⁵. The only exception was for UK, who do not truncate their national metric.

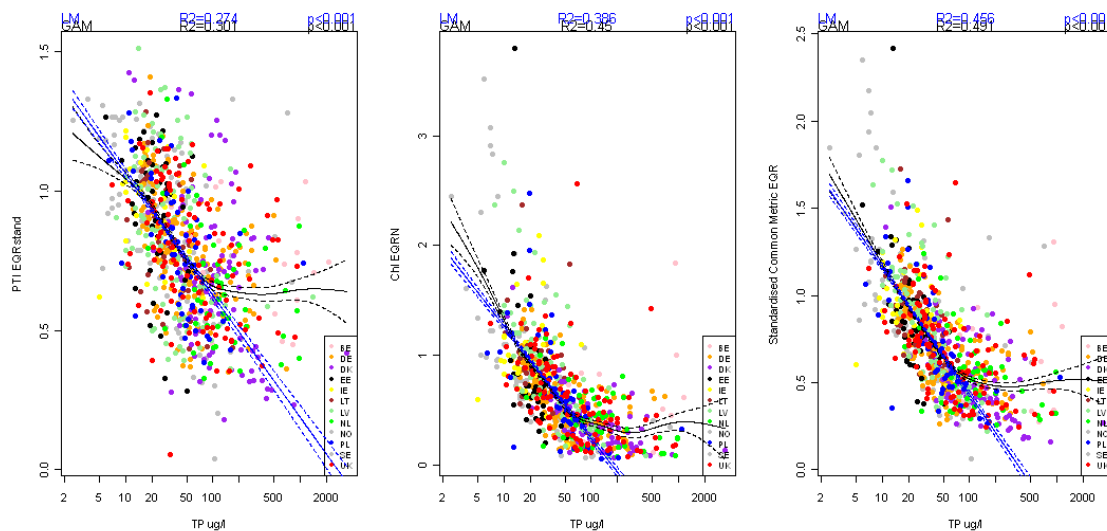

Figure E.9 Relationship between standardised PTI EQR, transformed Chlorophyll a EQR and proposed common metric EQR (average of PTI and Chlorophyll EQRs).

¹⁵ Variable name used in *spreadsheets* MM2EQRN - non truncated Common Metric EQR and MM2EQR_T the truncated Common Metric EQR

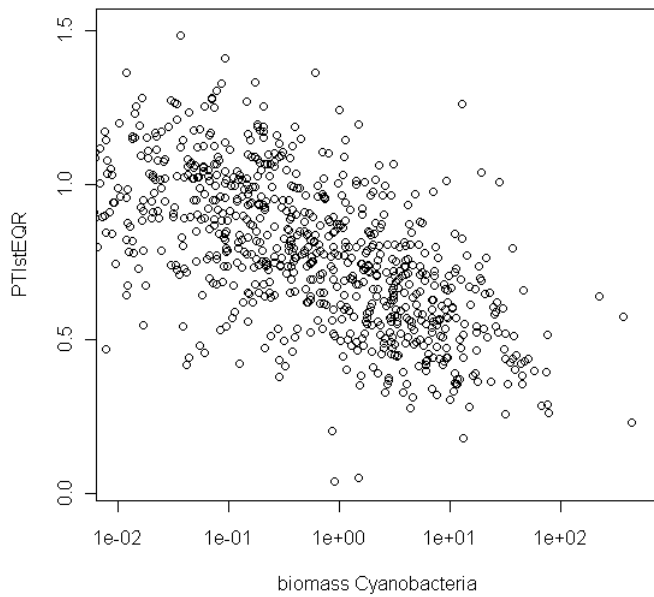

Figure E.10 Relationship between biomass of cyanobacteria and standardised PTI EQR in high alkalinity lakes from Central Baltic and Northern GIGs.

Standardise Common Metric

At the validation workshop it was suggested that the GIG should provide further evidence that the final common metric did not require further standardisation to remove bio-geographic differences.

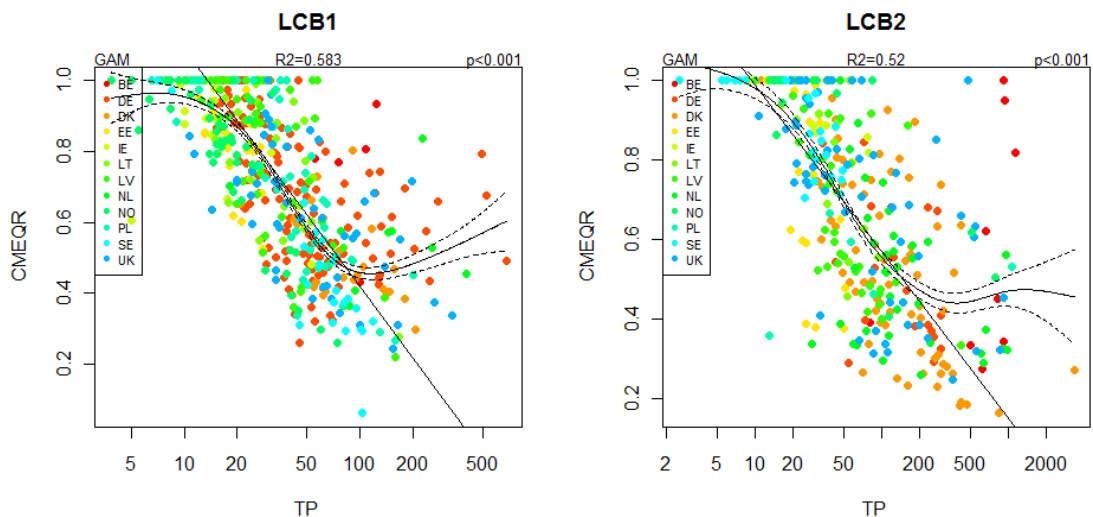

Figure E.11 Relationship between final Common Metric and total phosphorus in a)LCB1 and b)LCB2 lake types. Points coloured by country, lines show GAM model and linear mixed model with country as random factor.

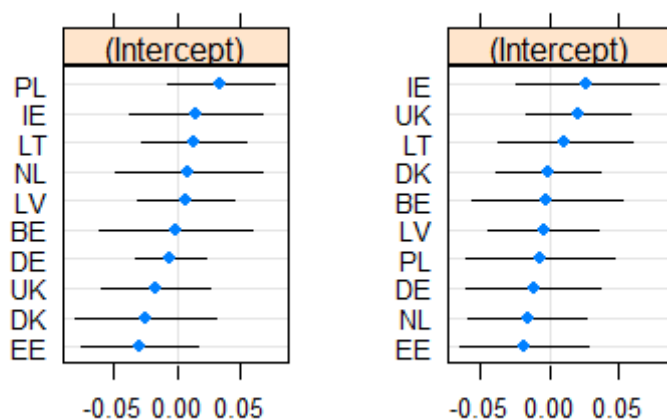

Figure E.12 values for intercepts of linear mixed model of Common Metric EQR v log TP with CBGIG country as a random factor. Lines show confidence limits of coefficients, data fitted to linear region of EQR v TP relationship (15-50 $\mu\text{gP l}^{-1}$ LCB1 and 20-200 $\mu\text{gP l}^{-1}$ LCB2)

The relationships between the common metric and total phosphorus for LCB1 and LCB2 lake types is shown in Figure E.11. Linear mixed models fitted to the linear range of EQR v logTP, with country as a random factor (Figure E.12) demonstrate that there were no significant country effects, as the confidence intervals of the random effects overlap. This was as expected, as the significant country effects for PTI were removed by standardisation prior to calculation of the EQRPTI and there was no evidence of country specific relationships between chlorophyll a and total phosphorus. Thus no further standardisation of the common metric was required.

References

- Bates, D., M. Maechler and B. Bolker (2011) *lme4: Linear mixed-effects models using eigen and singular systems*. R package version 0.9.9999.
- Birk, S., N. Willby and D. Nemitz (2011). *Users's manual of the intercalibration spreadsheets*.
- Oksanen, J., F. G. Blanchet, R. Kindt, P. Legendre, R. G. O'hara, G. L. Simpson, P. Solymos, M. H. H. Stevens and H. Wagner (2010) *Vegan: Community ecology package*.
- Phillips, G., G. Morabito, L. Carvalho, A. Lyche-Solheim, B. Skjelbred, J. Moe, T. Andersen, U. Mischke, C. De Hoyos and G. Borics (2010). Deliverable d3.1-1: Report on lake phytoplankton composition metrics, including a common metric approach for use in intercalibration by all gigs.
- Poikane, S. (2010) *Water framework directive intercalibration technical report Part 2: lakes* Luxembourg, European Commission.
- Wood, S. N. (2006). *Generalized additive models: An introduction with R*, Chapman and Hall.

Table E.7 List of taxon optima used to derive PTI score for Common Metric

Taxon	Optima	Records
Acanthoceras	0.401	167
Achnanthes	-0.590	95
Achnantheidium	-0.437	17
Achroonema	1.156	43
Actinastrum	2.867	102
Actinocyclus	3.672	49
Amphora	1.757	41
Anabaena	1.022	917
Anabaena flos-aquae group	1.280	592
Anabaena lemmermannii group	-0.010	305
Anabaenopsis	2.864	33
Ankistrodesmus	0.666	208
Ankyra	0.085	360
Aphanizomenon	1.700	559
Aphanocapsa	0.695	370
Aphanothece	0.231	333
Asterionella	-0.142	856
Aulacoseira	0.787	853
Aulacoseira alpigena group	-0.410	217
Aulacoseira granulata group	1.420	522
Bitrichia	-1.430	620
Botryococcus	-0.958	619
Carteria	-0.341	140
Centrales	1.286	410
Centritractus	0.811	36
Ceratium	0.655	771
Chlamydocapsa	0.361	12
Chlamydomonas	0.185	835
Chlorella	1.237	27
Chlorococcales	-0.423	704
Chlorogonium	2.334	18
Chlorophyceae	1.896	123
Chlorotetraedron	1.619	16

Taxon	Optima	Records
Chromulina	-1.184	409
Chroococcales	0.881	249
Chroococcus	0.486	445
Chroomonas	-0.823	510
Chrysidiastrum	-1.288	143
Chrysochromulina	-0.440	727
Chrysococcus	-0.374	264
Chrysolykos	-1.910	310
Chrysophyceae	-1.337	862
Chrysosphaerella	-0.751	56
Chrysostephanosphaera	-1.472	28
Closteriopsis	1.859	49
Closterium	0.976	632
Cocconeis	1.327	62
Coelastrum	1.746	305
Coelosphaerium	0.864	116
Coenochloris	0.293	52
Coenococcus	-0.973	8
Coenocystis	0.351	8
Colacium	0.068	12
Cosmarium	0.000	558
Cosmarium bioculatum group	0.560	81
Cosmarium formosulum/humile	1.830	18
Crucigenia	0.058	423
Crucigeniella	0.130	188
Cryptomonadales	0.479	73
Cryptomonas	0.204	1539
Cryptophyceae	1.518	63
Cyanodictyon	0.294	207
Cyanonephron	0.545	15
Cyanophyceae	1.672	162
Cyclostephanos	2.337	89
Cyclotella	-0.480	751
Cyclotella meneghiniana group	1.320	201
Cylindrospermopsis	1.871	42
Cylindrotheca	1.566	13
Cymatopleura	1.665	12
Cymbella	1.117	43
Diatoma	1.314	158
Dictyosphaerium	0.102	461

Taxon	Optima	Records
Didymocystis	0.226	146
Dinobryon	-0.749	1208
Dinophyceae	-1.250	471
Diplochlois	3.689	23
Discostella	-1.456	216
Elakatothrix	-0.941	786
Epipyxis	-1.085	129
Erkenia	0.819	20
Euastrum	-0.422	73
Eudorina	0.839	118
Euglena	1.646	239
Euglenophyceae	1.819	15
Eunotia	-0.232	98
Fragilaria	0.290	837
Franceia	1.274	19
Frustulia	-1.341	13
Glenodinium	0.193	41
Gloeocystis	-1.099	57
Gloeotila	-1.210	126
Golenkinia	1.601	40
Gomphonema	1.640	24
Gomphosphaeria	1.623	53
Goniochloris	2.451	58
Gonium	0.973	12
Gonyostomum	-0.120	243
Gymnodinium	-1.072	1042
Gyrosigma	1.440	23
Isthmochloron	-1.922	25
Katodinium	-0.716	10
Kephyrion	-1.011	415
Keratococcus	0.404	11
Kirchneriella	1.145	224
Koliella	-0.693	272
Lagerheimia	1.996	136
Limnothrix	1.701	188
Lyngbya	2.224	18
Mallomonas	-0.645	961
Melosira	1.371	48
Merismopedia	-1.163	584
Merismopedia punctata group	1.610	46

Taxon	Optima	Records
Micractinium	1.378	67
Microcystis	1.851	432
Microcystis aeruginosa/wesenbergii	1.490	429
Microcystis flos-aquae/viridis	1.920	94
Microsystis botrys/novacekii	0.460	33
Monochrysis	-1.074	167
Monomastix	-0.822	270
Monomorpha	1.976	40
Monoraphidium	-0.699	1182
Monoraphidium contortum group	1.290	982
Monoraphidium dybowskii/griffithii	-1.130	1011
Mougeotia	0.186	253
Navicula	1.174	148
Nephrochlamys	2.327	22
Nephrocytium	-0.406	100
Nephroselmis	0.560	21
Nitzschia	1.892	438
Ochromonadales	-1.670	257
Ochromonas	-1.270	591
Oocystis	-0.539	1088
Ophiocytium	0.612	20
Oscillatoria	1.533	164
Oscillatoriales	1.477	70
Pandorina	1.707	135
Paulschulzia	-0.107	61
Pediastrum	1.415	596
Pennales	1.025	137
Peridiniopsis	0.625	65
Peridinium	-0.209	1142
Phacotus	1.229	88
Phacus	2.031	157
Phormidium	1.391	14
Picoplankton	-1.297	651
Pinnularia	0.198	16
Plagioselmis	-0.585	1052
Plagioselmis	1.021	196
Planctonema	2.064	28
Planktolyngbya	1.569	221
Planktosphaeria	0.978	46
Planktothrix	1.502	471

Taxon	Optima	Records
Planktothrix isoetrix group	-0.250	51
Pseudanabaena	1.757	300
Pseudodictyosphaerium	0.437	10
Pseudogoniochloris	0.891	31
Pseudokephyrion	-1.720	445
Pseudopedinella	-1.116	586
Pseudosphaerocystis	-0.190	68
Pseudostaurastrum	1.842	51
Pteromonas	3.095	39
Puncticulata	0.149	29
Quadricoccus	3.203	17
Quadrigula	-0.662	335
Radiocystis	-0.725	96
Raphidocelis	-0.024	130
Rhabdoderma	-0.267	30
Rhabdogloea	-1.747	33
Rhodomonas	0.866	108
Romeria	1.328	34
Scenedesmus	1.549	798
Scenedesmus ecornis group	0.640	222
Scenedesmus quadricauda group	2.190	744
Schroederia	1.769	75
Scourfieldia	-1.236	339
Siderocelis	2.018	22
Skeletonema	3.064	46
Snowella	-0.021	587
Spermatozopsis	2.028	33
Sphaerocystis	-0.163	307
Spiniferomonas	-1.373	490
Spondylosium	-0.782	126
Staurastrum	0.548	637
Staurastrum cingulum group	-0.570	306
Staurastrum gracile group	0.820	168
Staurodesmus	-1.096	333
Stauroneis	2.986	13
Stausosira	2.115	54
Stephanodiscus	1.622	329
Stichococcus	1.232	18
Stichogloea	-1.375	215
Surirella	1.858	27

Taxon	Optima	Records
Syncrypta	0.718	14
Synechococcus	1.073	38
Synura	-0.274	322
Tabellaria	-0.669	629
Teilingia	-0.584	52
Tetraëdriella	-0.469	57
Tetraedron	0.568	545
Tetraselmis	0.181	18
Tetrastrum	0.727	194
Tetrastrum komarekii/triangulare	0.140	131
Tetrastrum staurogeniaeforme/triacanthum	1.800	68
Thalassiosira	2.482	11
Trachelomonas	1.258	414
Treubaria	1.168	81
Tribonema	1.200	28
Trichormus	1.519	58
Ulnaria	1.003	566
Ulothrix	1.618	14
Uroglena	-0.660	445
Urosolenia	-0.643	499
Volvocales	0.893	162
Volvox	1.564	15
Westella	0.831	12
Willea	-1.011	74
Woronichinia	0.069	393
Xanthidium	-0.143	53

Intercalibration of biological elements for lake water bodies

Table E.8 Species allocated to grouped genera (other species in genera take generic score shown in Table E.7)

Rebecca ID	Genus	Genus Group	AcceptedTaxon	Optima	Species Records	
R1534	Anabaena	Anabaena lemmermannii group	Anabaena curva	-0.01	11	
R1905			Anabaena danica		5	
R1539			Anabaena lemmermannii		154	
R1540			Anabaena macrospora		40	
R1544			Anabaena planctonica		95	
R2189		Anabaena flos-aquae group	Anabaena bergii var. limnetica	1.28	5	
R2161			Anabaena catenula var. affinis		11	
R1531			Anabaena circinalis		63	
R1532			Anabaena compacta		12	
R1533			Anabaena crassa		41	
R1536			Anabaena flos-aquae		330	
R1541			Anabaena mendotae		13	
R1545			Anabaena smithii		9	
R1549			Anabaena spiroides		108	
R0019			Aulacoseira		Aulacoseira alpigena group	Aulacoseira alpigena
R0021		Aulacoseira distans		132		
R0033	Aulacoseira subarctica	55				
R0034	Aulacoseira tenella	38				
R0020	Aulacoseira granulata group	Aulacoseira ambigua		1.42	153	
R0023		Aulacoseira granulata			277	
R0024		Aulacoseira granulata var. angustissima			92	
R1205	Cosmarium	Cosmarium bioculatum group	Cosmarium bioculatum	0.56	25	

Intercalibration of biological elements for lake water bodies

Rebecca ID	Genus	Genus Group	AcceptedTaxon	Optima	Species Records		
R1214			Cosmarium granatum		14		
R1215			Cosmarium impressulum		4		
R1217			Cosmarium margaritiferum		18		
R1222			Cosmarium protractum		5		
R1224			Cosmarium punctulatum		3		
R1231			Cosmarium reniforme		10		
R1245			Cosmarium turpinii		2		
R1213			Cosmarium formosulum/humile		Cosmarium formosulum	1.83	10
R2284					Cosmarium humile		8
R0039			Cyclotella		Cyclotella meneghiniana group	Cyclotella atomus	1.32
R2195	Cyclotella cyclopuncta	5					
R0047	Cyclotella meneghiniana	100					
R0048	Cyclotella ocellata	40					
R1475	Merismopedia	Merismopedia punctata group	Merismopedia glauca	1.61	8		
R1476			Merismopedia minima		18		
R1477			Merismopedia punctata		20		
R1483	Microcystis	Microsystis botrys/novacekii	Microcystis botrys	0.46	18		
R1494			Microcystis novacekii		15		
R1482		Microcystis aeruginosa/wesenbergii	Microcystis aeruginosa	1.49	262		
R1499			Microcystis wesenbergii		167		
R1487		Microcystis flos-aquae/viridis	Microcystis flos-aquae	1.92	50		
R1498			Microcystis viridis		44		
R0667		Monoraphidium	Monoraphidium dybowskii/griffithii	Monoraphidium dybowskii	-1.13	709	

Intercalibration of biological elements for lake water bodies

Rebecca ID	Genus	Genus Group	AcceptedTaxon	Optima	Species Records		
R0670			Monoraphidium griffithii		302		
R0663		Monoraphidium contortum group	Monoraphidium arcuatum	1.29	60		
R0664			Monoraphidium circinale		31		
R0665			Monoraphidium contortum		442		
R0666			Monoraphidium convolutum		24		
R0672			Monoraphidium irregulare		20		
R0673			Monoraphidium komarkovae		179		
R0675			Monoraphidium minutum		191		
R0676			Monoraphidium mirabile		11		
R0677			Monoraphidium nanum		3		
R0683			Monoraphidium tortile		21		
R2147	Planktothrix		Planktothrix isothrix group		Planktothrix isothrix	-0.25	49
R1616		Planktothrix prolifica		2			
R0753	Scenedesmus	Scenedesmus ecornis group	Scenedesmus aculeolatus	0.64	11		
R0766			Scenedesmus brasiliensis		7		
R0781			Scenedesmus ecornis		149		
R0760			Scenedesmus obtusus		27		
R0810			Scenedesmus serratus		15		
R1922			Scenedesmus verrucosus		13		
R2552			Scenedesmus quadricauda group		Scenedesmus abundans	2.19	23
R0754					Scenedesmus acuminatus		100
R0763		Scenedesmus bicaudatus		44			
R0772		Scenedesmus costato-granulatus		18			

Intercalibration of biological elements for lake water bodies

Rebecca ID	Genus	Genus Group	AcceptedTaxon	Optima	Species Records
R0775			Scenedesmus denticulatus		28
R0777			Scenedesmus dimorphus		60
R0784			Scenedesmus granulatus		9
R0789			Scenedesmus intermedius		20
R0793			Scenedesmus longispina		4
R0794			Scenedesmus magnus		12
R0799			Scenedesmus opoliensis		90
R0806			Scenedesmus quadricauda		279
R0813			Scenedesmus spinosus		33
R0814			Scenedesmus subspicatus		24
R1275	Staurastrum	Staurastrum cingulum group	Staurastrum anatinum	-0.57	39
R1278			Staurastrum avicula		14
R1283			Staurastrum cingulum		63
R2608			Staurastrum cingulum var. obesum		11
R1284			Staurastrum erasum		8
R1291			Staurastrum longipes		19
R1293			Staurastrum luetkemulleri		19
R1295			Staurastrum lunatum		60
R1303			Staurastrum pingue		34
R1305			Staurastrum pseudopelagicum		34
R1308			Staurastrum smithii		5
R1282		Staurastrum gracile group	Staurastrum chaetoceras	0.82	24
R1286			Staurastrum furcigerum		5

Intercalibration of biological elements for lake water bodies

Rebecca ID	Genus	Genus Group	AcceptedTaxon	Optima	Species Records	
R1288	Tetrastrum		Staurastrum gracile		94	
R1301			Staurastrum paradoxum var. parvum		32	
R1311			Staurastrum tetracerum		13	
R0866			Tetrastrum komarekii/triangulare	Tetrastrum komarekii	0.14	47
R0873			Tetrastrum triangulare			84
R0871			Tetrastrum staurogeniaeforme/triacanthum	Tetrastrum staurogeniaeforme	1.8	64
R0872				Tetrastrum triacanthum		4

F. Relationship between MS metrics and Common Metric

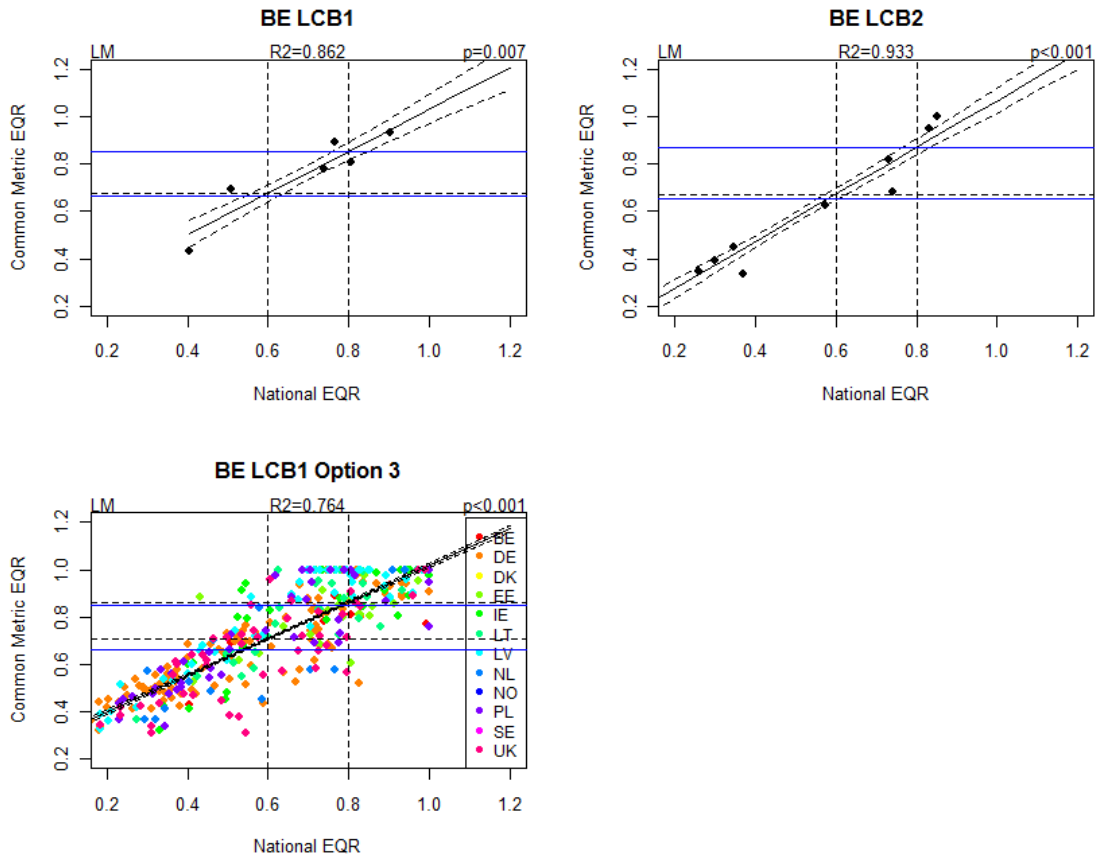

Figure F.1 Relationship between BE national metrics and Common Metric

LCB1 type, Option 2:

Multiple R-squared 0.8625; Adjusted R-squared 0.8281; p-value: 0.007445

LCB1 type, Option 3:

Multiple R-squared 0.7642; Adjusted R-squared: 0.7636; p-value: < 2.2e-16

LCB2 type Option 2:

Multiple R-squared: 0.933; Adjusted R-squared: 0.9247; p-value: 5.655e-06

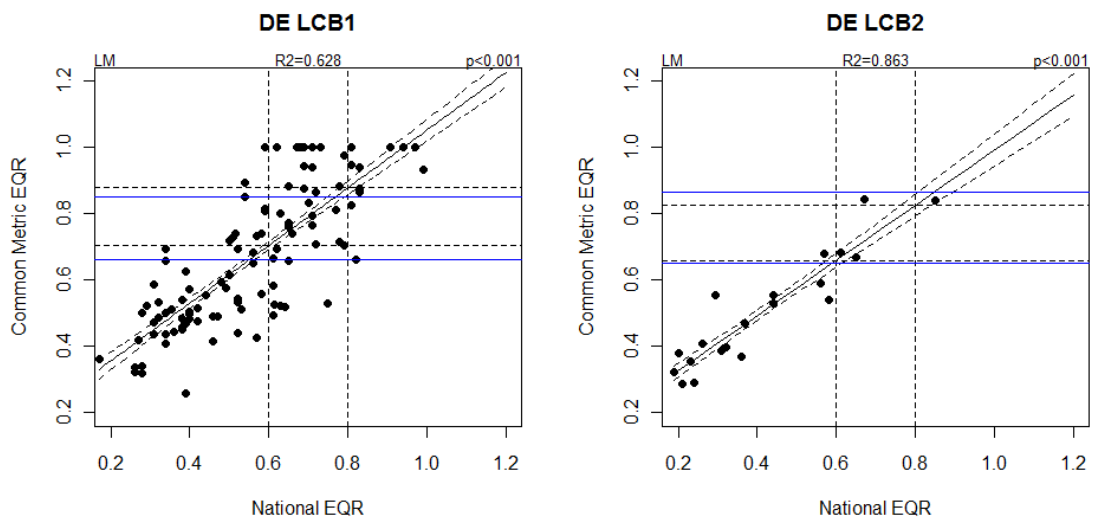

Figure F.2 Relationship between DE national metrics and Common Metric

LCB1 type, Option 2

Multiple R-squared 0.6275; Adjusted R-squared 0.6238; p-value < 2.2e-16

LCB2 type, Option 2

Multiple R-squared 0.8625; Adjusted R-squared 0.8549; p-value: 3.473e-09

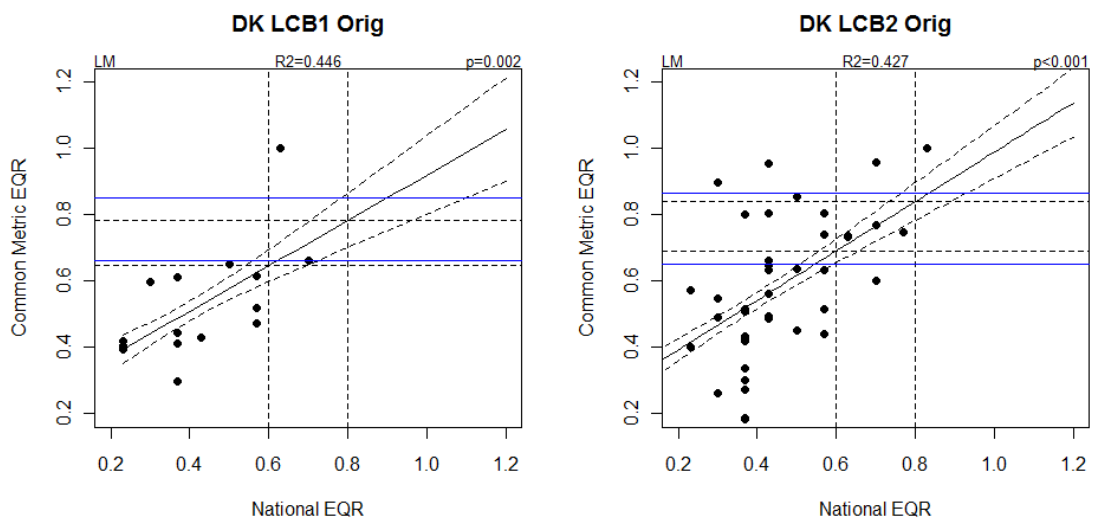

Figure F.3 Relationship between DK original national metrics and Common Metric

LCB1 type, Option 2

Multiple R-squared 0.4461; Adjusted R-squared 0.4115; p-value 0.002451

LCB2 type, Option 2

Multiple R-squared 0.427; Adjusted R-squared 0.4151; p-value 2.678e-07

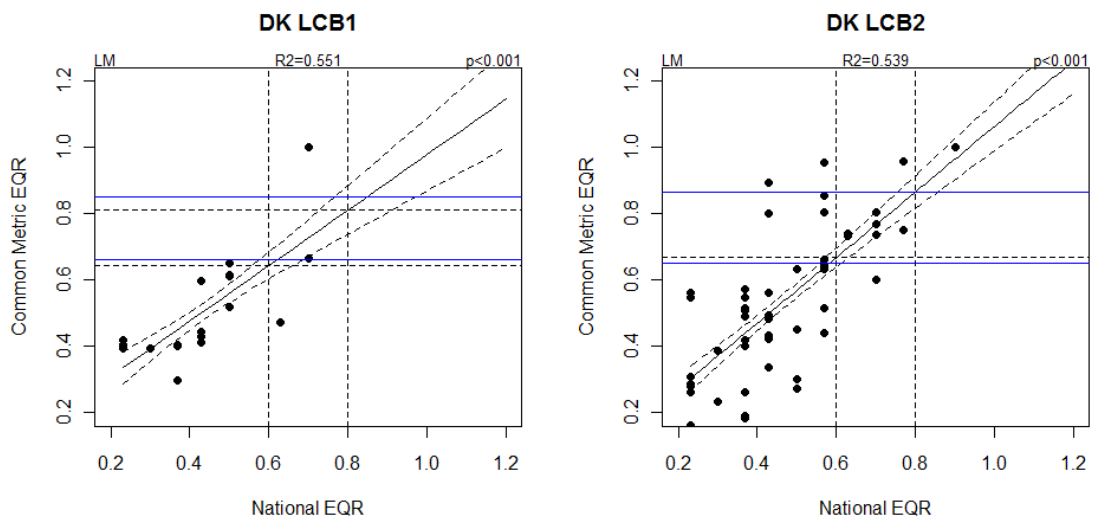

Figure F.4 Relationship between DK national metrics and Common Metric

LCB1 type, Option 2

Multiple R-squared 0.5507; Adjusted R-squared 0.5226; p-value 0.0004217

LCB2 type, Option 2

Multiple R-squared 0.5387; Adjusted R-squared 0.5291; p-value 1.324e-09

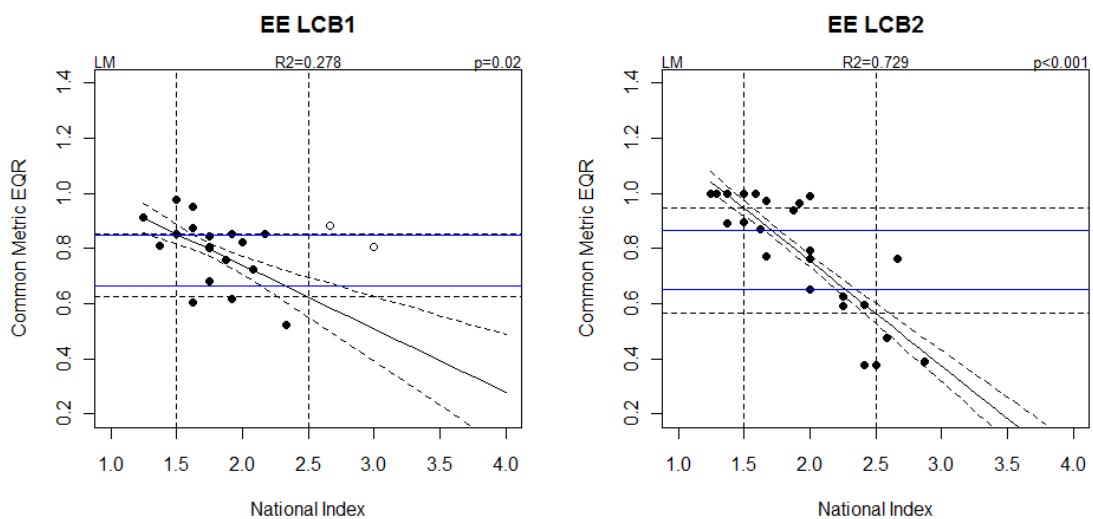

Figure F.5 Relationship between EE national metrics and Common Metric

LCB1 type, Option 2

Multiple R-squared 0.2776; Adjusted R-squared 0.2324; p-value 0.02467

LCB2 type, Option 2

Multiple R-squared 0.7289; Adjusted R-squared 0.7181; p-value 1.498e-08

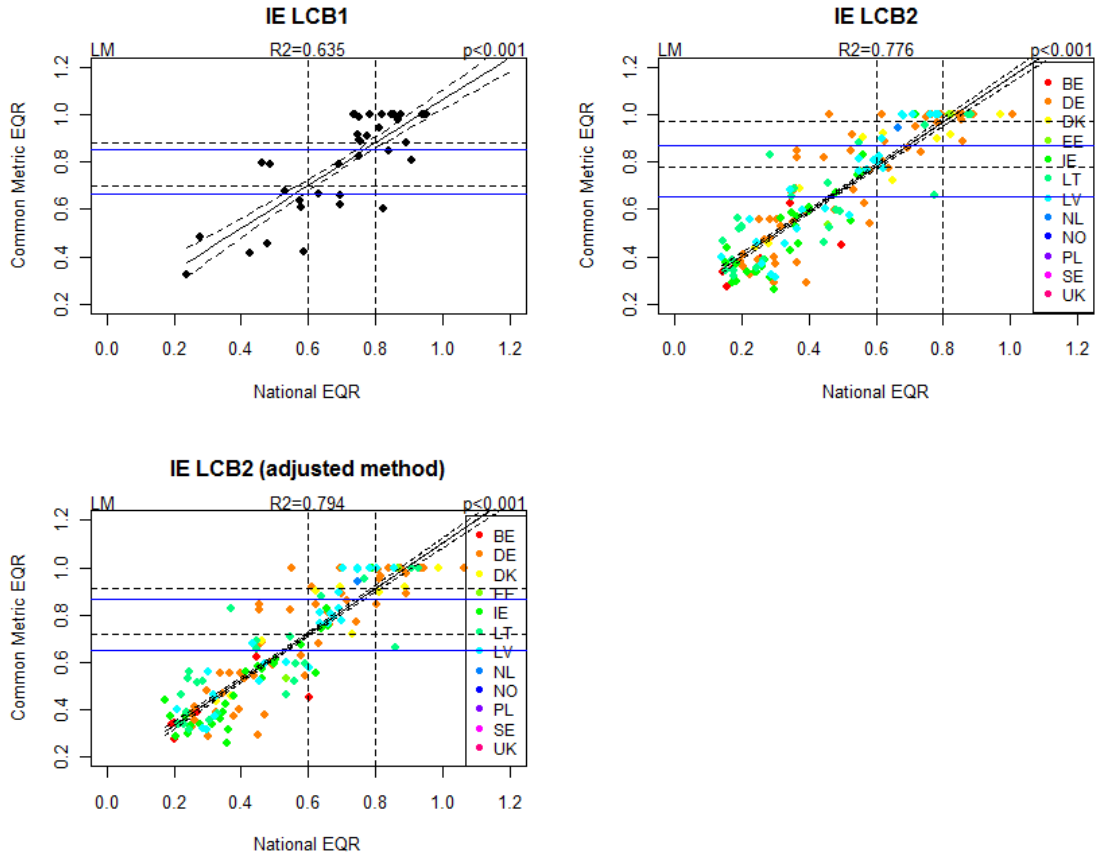

Figure F.6 Relationship between IE national metrics and Common Metric

LCB1 type, Option 2

Multiple R-squared 0.635; Adjusted R-squared 0.6242; p-value 6.09e-09

LCB2 type, Option 3

Multiple R-squared 0.776; Adjusted R-squared 0.7744; p-value: < 2.2e-16

LCB2 type, Option 3, IE method adjusted

Multiple R-squared 0.7936; Adjusted R-squared 0.7922; p-value < 2.2e-16

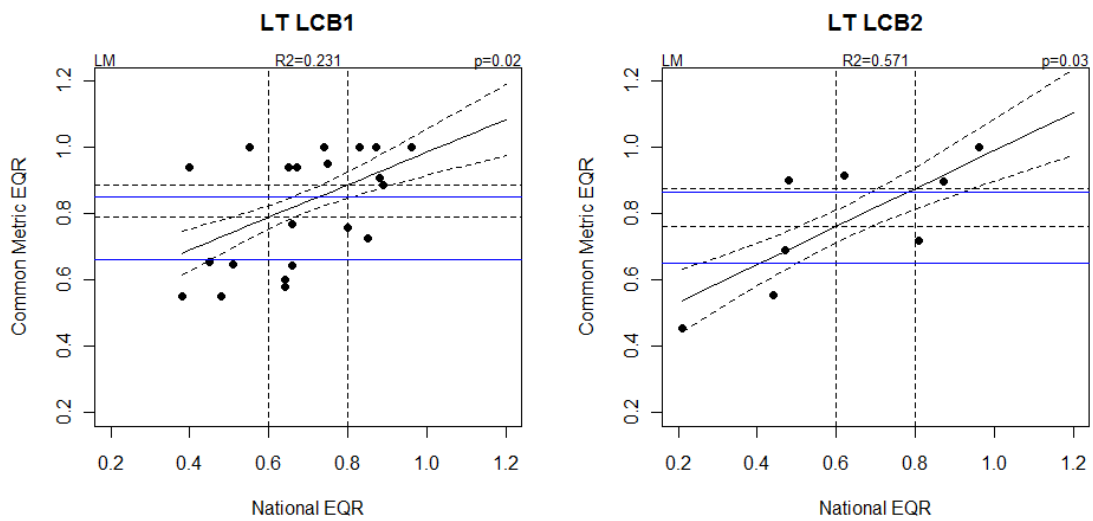

Figure F.7 Relationship between LT national metrics and Common Metric

LCB1 type, Option 2

Multiple R-squared 0.2309; Adjusted R-squared 0.1943; p-value 0.02028

LCB2 type, Option 2

Multiple R-squared 0.5709; Adjusted R-squared 0.4994; p-value: 0.03015

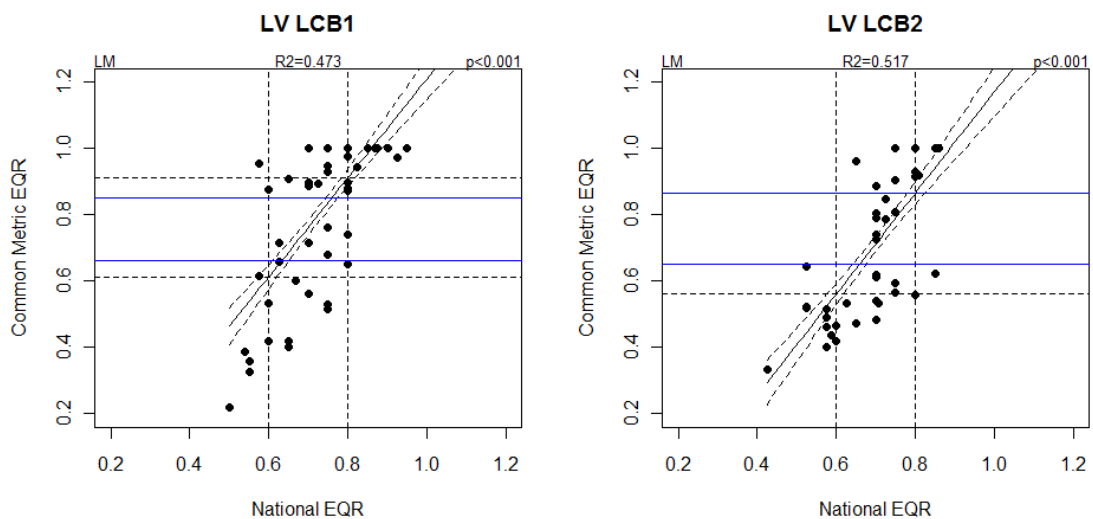

Figure F.8 Relationship between LV national metrics and Common Metric

LCB1 type, Option 2

Multiple R-squared 0.4734; Adjusted R-squared 0.4637; p-value 4.65e-09

LCB2 type, Option 2

Multiple R-squared 0.5166; Adjusted R-squared 0.5048; p-value: 5.704e-08

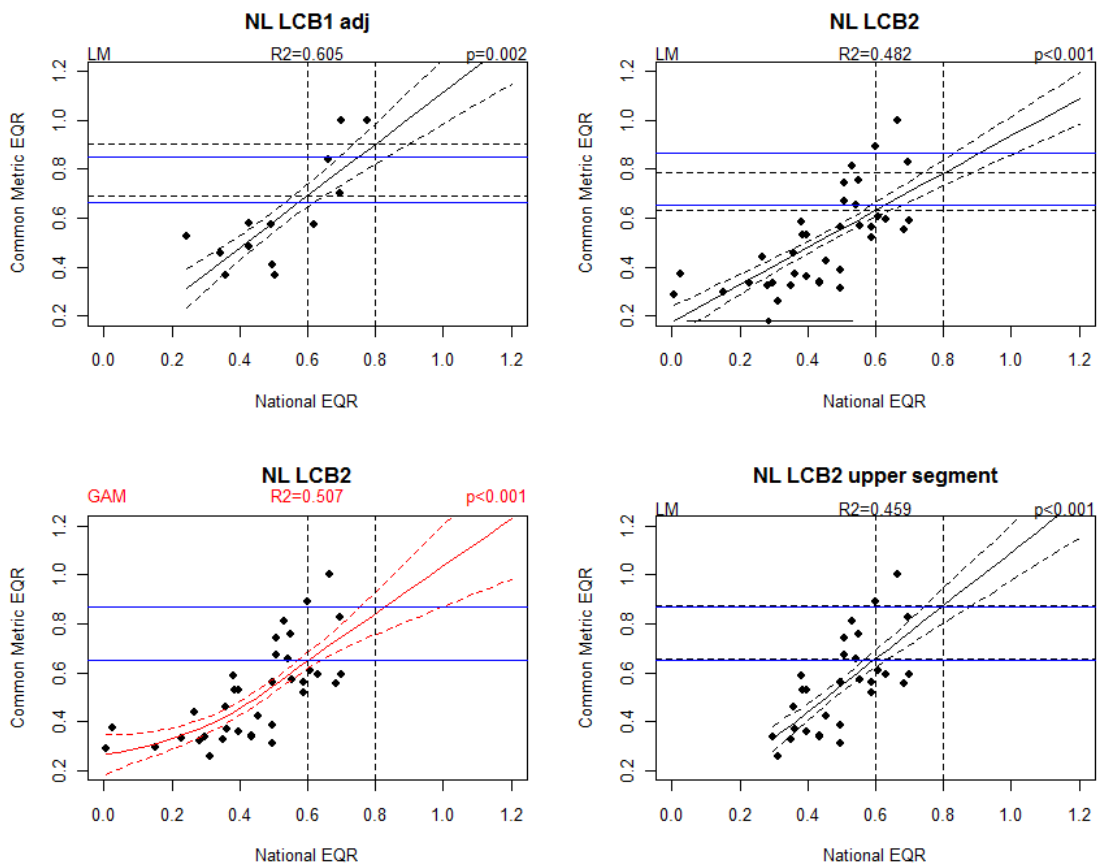

Figure F.9 Relationship between NL national metrics and Common Metric

LCB1 type, Option 2

Multiple R-squared 0.6053; Adjusted R-squared 0.5694; p-value 0.001737

LCB2 type, Option 2 (all data):

Multiple R-squared 0.1386; Adjusted R-squared 0.467; p-value: 2.629e-06

LCB2, Option 2, upper segment (NL EQR > 0.288)

Multiple R-squared 0.4594; Adjusted R-squared 0.4401; p-value: 3.872e-05

The NL metric for LCB2 lakes was clearly non-linear. This was caused by lakes in NL which had extremely high biomass resulting in a very low NL EQR (Poor or in some cases Bad status). A GAM model demonstrated this non-linearity and a segmented regression identified two linear segments split at a NL EQR of 0.288. This value is substantially below the Moderate status and to estimate the GM and HG boundaries on the Common Metric scale regressions based on the upper segment were used.

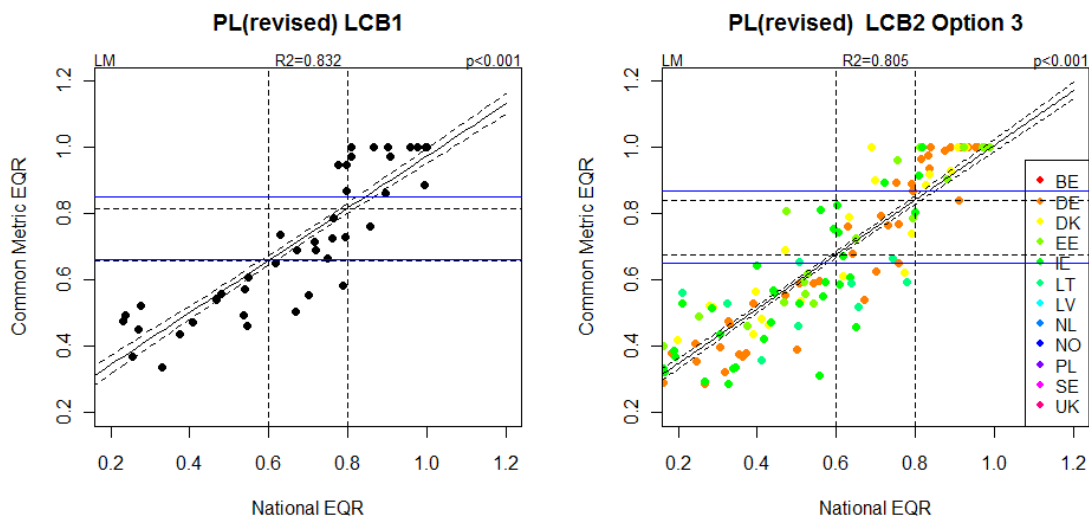

Figure F.10 Relationship between PL revised national metrics and Common Metric

LCB1 type, Option 2

Multiple R-squared 0.832; Adjusted R-squared 0.8283; p-value < 2.2e-16

LCB2 type, Option 3

Multiple R-squared 0.8048; Adjusted R-squared 0.8033; p-values: < 2.2e-16

The relationship between the Polish metric and the common metric for LCB1 lakes has a significant relationship. The GM boundary is within the harmonisation band, but the HG boundary is slightly below (-0.25). Changing the slope by a factor of +0.005 changes the Polish HG boundary on the Common Metric scale from 0.807 to 0.811, sufficient to reduce the boundary bias from -0.27 to -0.24 and thus bring the boundary within the harmonisation band. Given the uncertainty of the slope parameter, which has a standard error of ± 0.06 , (so the adjustment is <10% of the SE) and that the GM boundary is clearly within the harmonisation band it is proposed that there is no need to adjust the Polish HG boundary value. Further evidence for this comes from a jack knife regression in which all points are omitted from the regression in turn. Estimates of the slope using this technique are shown in Figure F.11 below.

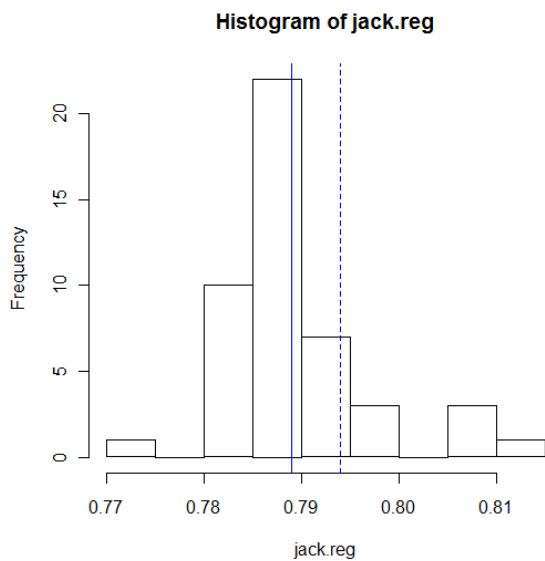

Figure F.11 Histogram of estimates of the slope of the relationship between Polish final EQR and Common Metric EQR when applied to Polish L-CB1 lakes. Solid vertical blue line shows value of regression slope for all data, dotted blue line shows slope adjusted to bring Polish HG boundary into harmonisation band.

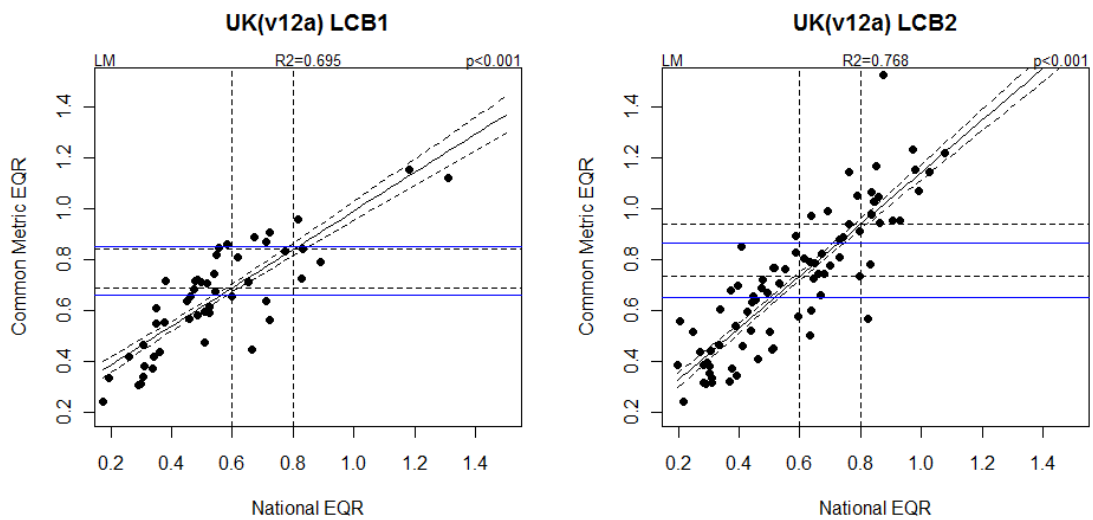

Figure F.12 Relationship between UK revised national metrics and Common Metric **LCB1 type, Option 2**

Multiple R-squared 0.6946; Adjusted R-squared 0.6881; p-value 1.08e-13

LCB2 type, Option 2

Multiple R-squared 0.7259; Adjusted R-squared 0.7224; p-values: < 2.2e-16

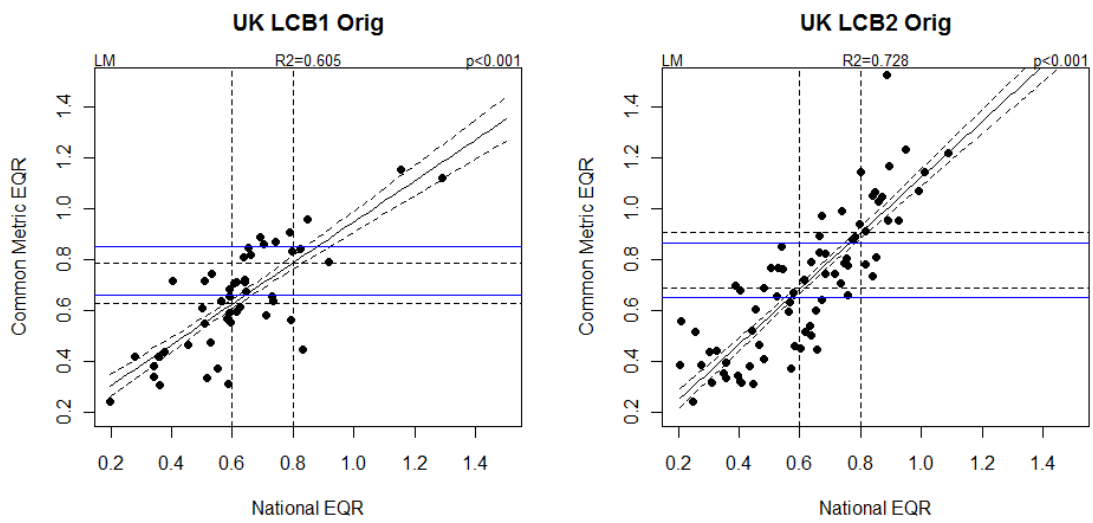

Figure F.13 Relationship between UK original national metrics and Common Metric

LCB1 type, Option 2

Multiple R-squared 0.6051; Adjusted R-squared 0.5965; p-value 7.794e-11

LCB2 type, Option 2

Multiple R-squared 0.7282; Adjusted R-squared 0.7245; p-value < 2.2e-16

Europe Direct is a service to help you find answers to your questions about the European Union
Freephone number (*): 00 800 6 7 8 9 10 11

(*): Certain mobile telephone operators do not allow access to 00 800 numbers or these calls may be billed.

A great deal of additional information on the European Union is available on the Internet.
It can be accessed through the Europa server <http://europa.eu/>.

How to obtain EU publications

Our priced publications are available from EU Bookshop (<http://bookshop.europa.eu>),
where you can place an order with the sales agent of your choice.

The Publications Office has a worldwide network of sales agents.
You can obtain their contact details by sending a fax to (352) 29 29-42758.

European Commission
EUR 26508 EN – Joint Research Centre – Institute for Environment and Sustainability

Title: Water Framework Directive Intercalibration Technical Report: Central Baltic Lake Phytoplankton ecological
assessment methods

Authors: Geoff Phillips, Gary Free, Ivan Karottki, Christophe Laplace-Treyture, Kairi Maileht, Ute Mischke, Ingmar Ott,
Agnieszka Pasztaleniec, Rob Portielje, Martin Søndergaard, Wayne Trodd, Jeroen Van Wichelen

Edited by Sandra Poikane

Luxembourg: Publications Office of the European Union

2014 – 184 pp. – 21.0 x 29.7 cm

EUR – Scientific and Technical Research series – ISSN 1831-9424

ISBN 978-92-79-35463-2

doi: 10.2788/73991

Abstract

One of the key actions identified by the Water Framework Directive (WFD; 2000/60/EC) is to develop ecological assessment tools and carry out a European intercalibration (IC) exercise. The aim of the Intercalibration is to ensure that the values assigned by each Member State to the good ecological class boundaries are consistent with the Directive's generic description of these boundaries and comparable to the boundaries proposed by other MS.

In total, 83 lake assessment methods were submitted for the 2nd phase of the WFD intercalibration (2008-2012) and 62 intercalibrated and included in the EC Decision on Intercalibration (EC 2013). The intercalibration was carried out in the 13 Lake Geographical Intercalibration Groups according to the ecoregion and biological quality element. In this report we describe how the intercalibration exercise has been carried out in the Central Baltic Lake Phytoplankton IC group.

JRC Mission

As the Commission's in-house science service, the Joint Research Centre's mission is to provide EU policies with independent, evidence-based scientific and technical support throughout the whole policy cycle.

Working in close cooperation with policy Directorates-General, the JRC addresses key societal challenges while stimulating innovation through developing new methods, tools and standards, and sharing its know-how with the Member States, the scientific community and international partners.

*Serving society
Stimulating innovation
Supporting legislation*

