



HAL
open science

The influence of riverbank stabilization techniques on taxonomic and functional macrobenthic diversity

P. Cavaillé, B. Dumont, K. van Looy, Mathieu Floury, E. Tabacchi, A. Evette

► To cite this version:

P. Cavaillé, B. Dumont, K. van Looy, Mathieu Floury, E. Tabacchi, et al.. The influence of riverbank stabilization techniques on taxonomic and functional macrobenthic diversity. EcoSummit, Aug 2016, Montpellier, France. pp.1, 2016. hal-02604612

HAL Id: hal-02604612

<https://hal.inrae.fr/hal-02604612v1>

Submitted on 16 May 2020

HAL is a multi-disciplinary open access archive for the deposit and dissemination of scientific research documents, whether they are published or not. The documents may come from teaching and research institutions in France or abroad, or from public or private research centers.

L'archive ouverte pluridisciplinaire **HAL**, est destinée au dépôt et à la diffusion de documents scientifiques de niveau recherche, publiés ou non, émanant des établissements d'enseignement et de recherche français ou étrangers, des laboratoires publics ou privés.

The influence of riverbank stabilization techniques on taxonomic and functional macrobenthic diversity

Taxonomical analysis



(Photo: Cavaille)

Surber macroinvertebrate sampling on the immersed part of a rip-rap (Vorze, Isère).

Methods

- Habitat survey.
- Five Surber samples on the most qualitative habitats.

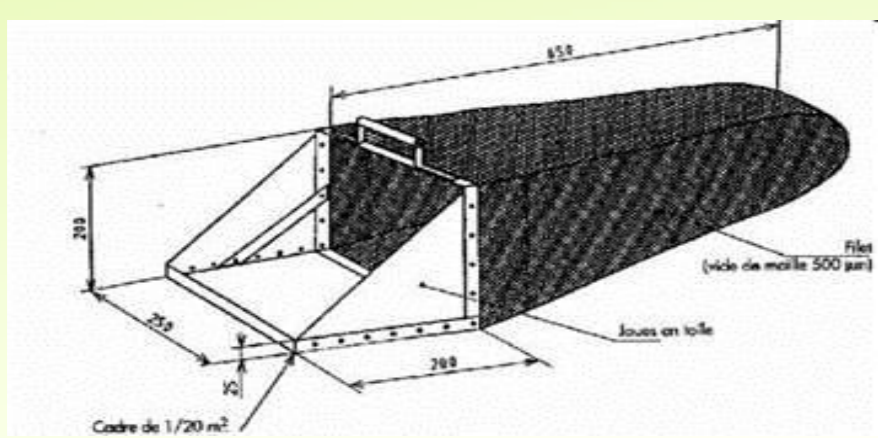

Taxonomic results

273 taxa were identified from the 35 sites sampled stretch

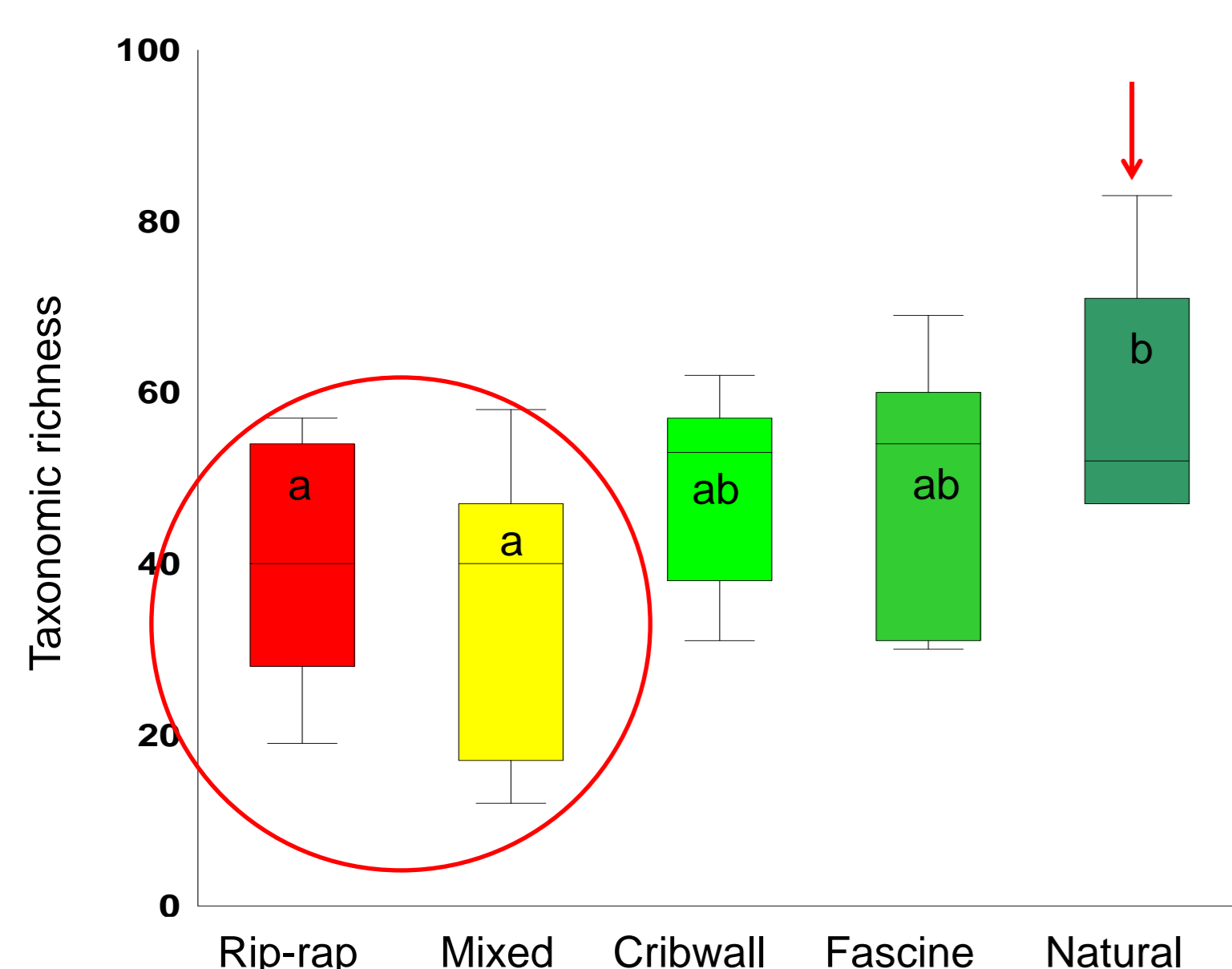

Taxonomic richness for each riverbank type

Taxonomic richness on Rip-rap and Mixed riverbank richness was significantly lower than on Natural riverbank.

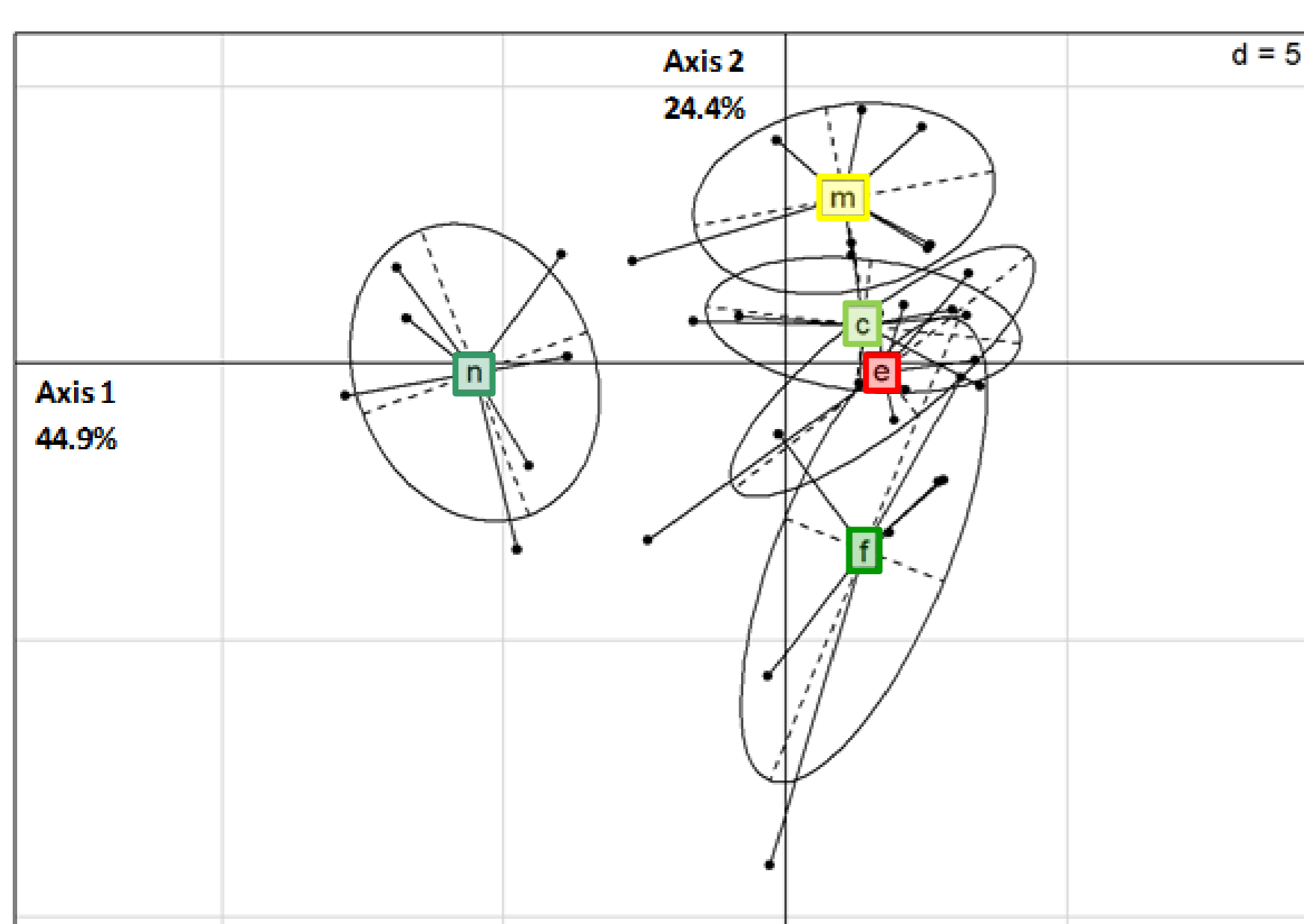

Macrobenthic communities on five riverbank types

Natural bank macrobenthic community differed significantly from the engineered riverbank.

Paul Cavaille, Bernard Dumont, Kris Van Looy, Mathieu Floury, Eric Tabacchi, André Evette

Context, Objective :

Channelization has increased in piedmont areas with **urbanization** and other **anthropogenic alterations**. Changes in riparian structures and in sediment dynamics have **affected riparian biodiversity** including aquatic macroinvertebrate richness. In this context, **riverbank restoration** becomes a major issue in preserving **stream ecosystem functioning and associated services**. As a relevant integrator of environmental changes in river systems, **macroinvertebrate communities** are likely to readily respond to a combination of anthropogenic disturbances.

We aimed at assessing the response of the **taxonomic and functional characteristics of benthic macroinvertebrate communities** along a gradient of managed riverbank naturalness.

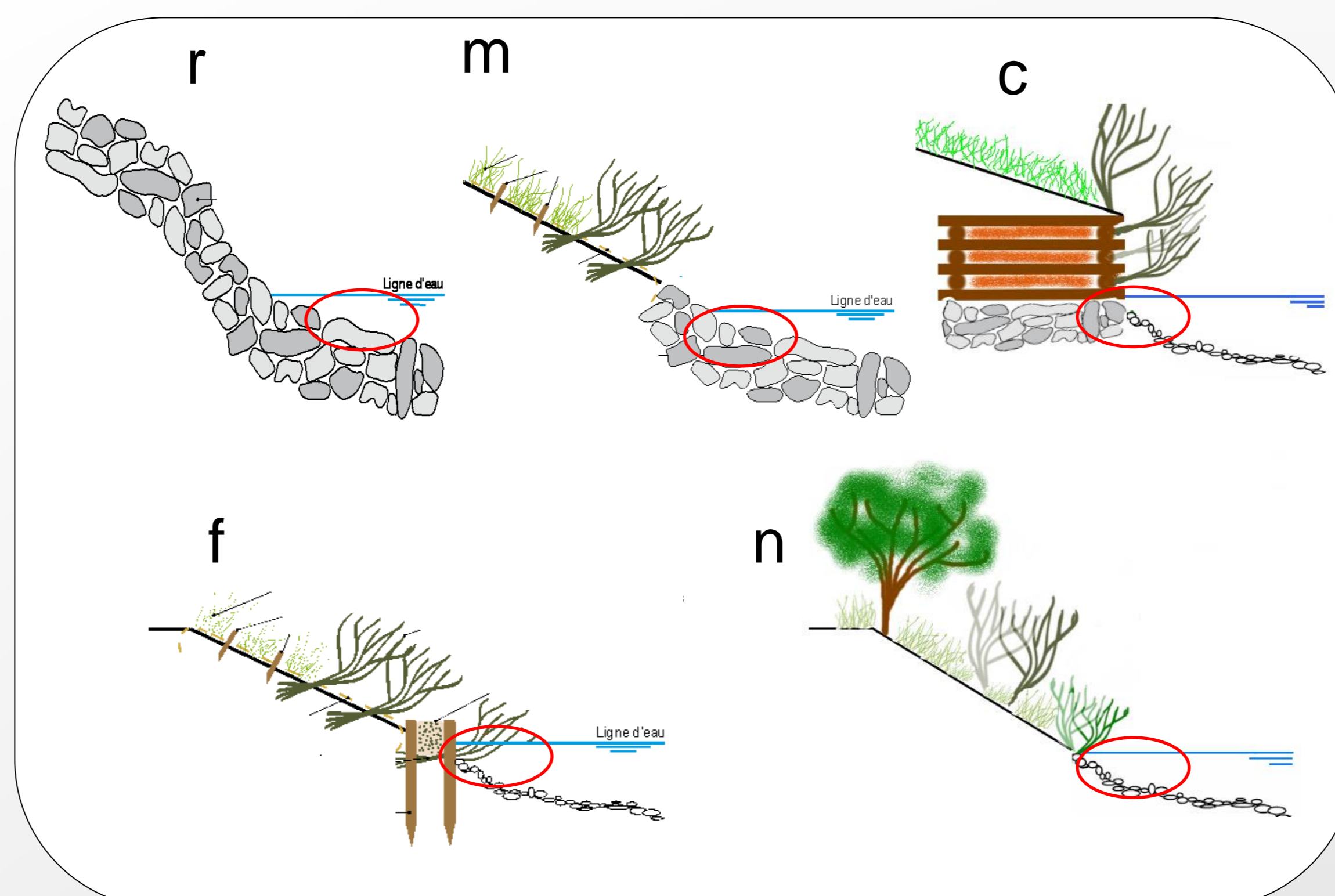

Blueprint of riverbank protection techniques : (r) rip-rap; (m) mixed technique; (c) vegetated cribwall; (f) willow fascine; (n) natural bank.

Main results:

- Lower richness of benthic macroinvertebrates on engineered bank.
- A shift in macrobenthic communities to small and short-life cycle taxa on **Natural banks**.

Discussion:

- Riverbank stabilisation limits **local sedimentary** dynamics with the end in a **lack of habitat diversity and heterogeneity**.
- Embankments were sampled 3 to 7 years after works, the **period for the colonization of the new habitats** is probably structuring restored communities.

Perspectives:

Sampling effort and a **comparative analysis** of a **nearby reference community** could be useful to **measure resilience (or restoration success)** of every bank stabilisation technics.

Functional traits analysis



(Source: PERLA DIREN Auvergne)

Plecoptera (protonemura) larvae

Methods

Biological traits were extracted from Tachet et al. (2010)

Seven biological traits were selected to be relevant to **colonization dynamics, trophic organisation, and habitat characteristics**:

- **Life history traits** with "Maximum potential size," "Life cycle duration" and "Potential number of cycles per year";
- **Potential resistance and resilience** of organisms with "Dissemination";
- **Behavioural aspects** of reproduction and nutrition with "Reproduction," "Feeding habits," and "Trophic status."

Results

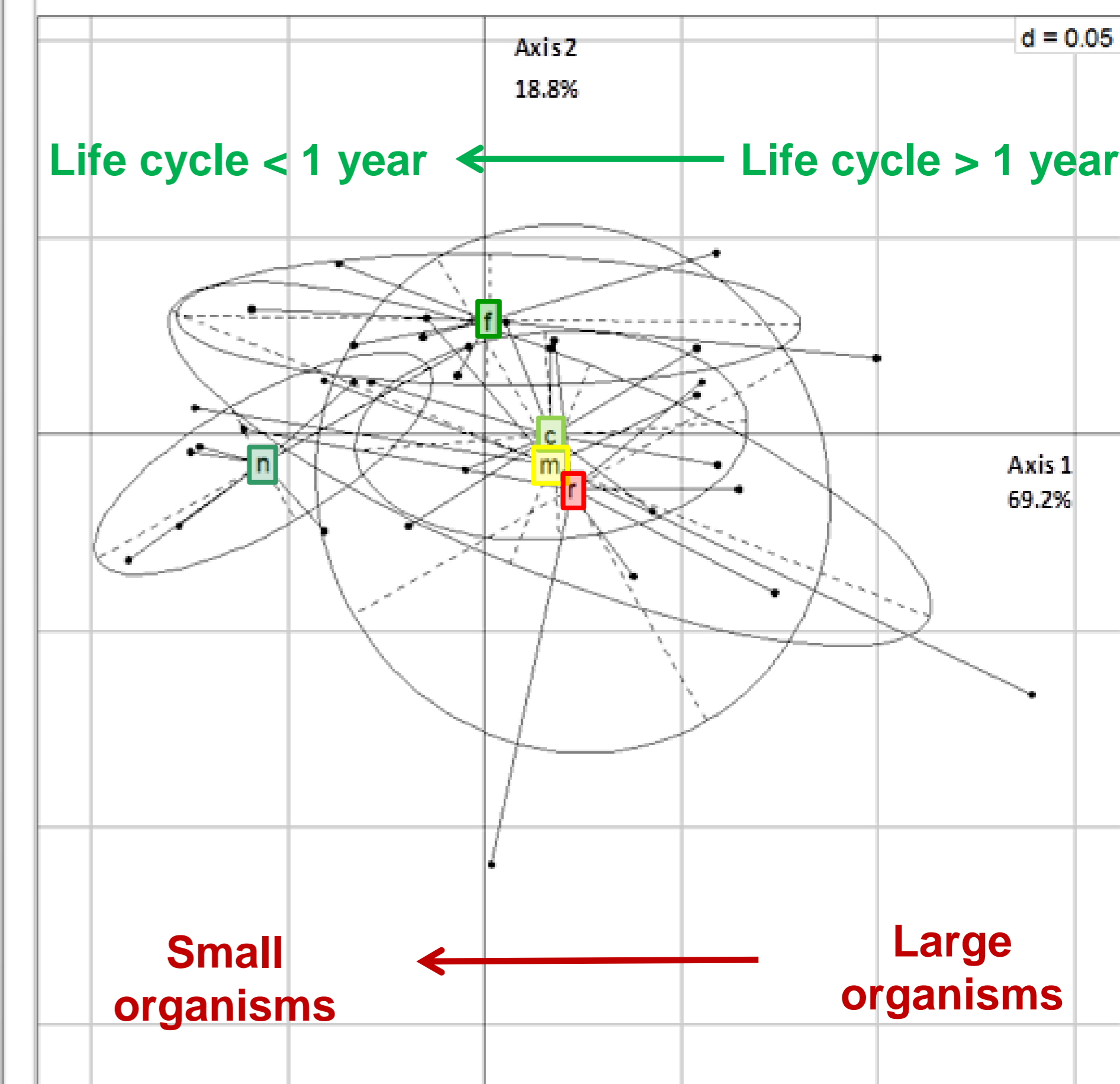

Macrobenthic trait-based structure on five riverbank types

- Organisms welcomed on **Natural riverbank** are **smaller** and with a **shorter life cycle** that suggested a **greater community resilience on Natural banks** compared to protected banks.
- A shift in macrobenthic communities with a higher proportion of **generalist species welcomed on Natural banks**.