



HAL
open science

Selecting ultrafiltration membranes for fractionation of high added value compounds from grape pomace extracts

Sami S. Yammine, Robin Rabagliato, Xavier Vitrac, Martine Mietton Peuchot, Remy Ghidossi

► **To cite this version:**

Sami S. Yammine, Robin Rabagliato, Xavier Vitrac, Martine Mietton Peuchot, Remy Ghidossi. Selecting ultrafiltration membranes for fractionation of high added value compounds from grape pomace extracts. *OENO One*, 2019, 53 (3), pp.487-497. 10.20870/oeno-one.2019.53.3.2343 . hal-02617942

HAL Id: hal-02617942

<https://hal.inrae.fr/hal-02617942>

Submitted on 25 May 2020

HAL is a multi-disciplinary open access archive for the deposit and dissemination of scientific research documents, whether they are published or not. The documents may come from teaching and research institutions in France or abroad, or from public or private research centers.

L'archive ouverte pluridisciplinaire **HAL**, est destinée au dépôt et à la diffusion de documents scientifiques de niveau recherche, publiés ou non, émanant des établissements d'enseignement et de recherche français ou étrangers, des laboratoires publics ou privés.



Distributed under a Creative Commons Attribution - NonCommercial 4.0 International License

Selecting ultrafiltration membranes for fractionation of high added value compounds from grape pomace extracts

Sami Yammine¹, Robin Rabagliato¹, Xavier Vitrac², Martine Mietton Peuchot¹ and Rémy Ghidossi¹

¹Université Bordeaux, ISVV, Unité de recherche Œnologie, EA 4577, USC 1366 Inra, Bordeaux INP, 33882 Villenave d'Ornon, France

²Laboratoire Phenobio SAS, Centre Montesquieu, 1 allée Jean Rostand, 33650 Martillac, France

Corresponding author: remy.ghidossi@u-bordeaux.fr

ABSTRACT

The purpose of the current study is to investigate the use of ultrafiltration membrane for the fractionation of phenolic compounds from subcritical water grape pomace extract and the separation of these compounds from other co-extracted components. The extract was assayed in a cross-flow apparatus against eleven membranes with molecular weight ranging from 100 to 2 kDa. Monitoring of the process was executed by determining performance parameters and retention coefficients of proteins, polysaccharides, sugars, phenolic and anthocyanin classes. Results indicated that retention of solutes was affected, not by size exclusion, but primarily by severe fouling phenomena due to polar solutes adsorption on the membrane surface. With the exception of the separation obtained between polymeric and monomeric proanthocyanidins, polysulfone membranes were not able to fractionate phenolic classes. Membranes starting of 20 kDa and over retained high percentages (>60%) of polysaccharides and proteins.

KEYWORDS

ultrafiltration, grape pomace, proteins, pectins, phenolic compounds

ABBREVIATIONS

AUC Area under the curve - CCD charge-coupled device - C_{if} concentrations of compound in feed - C_{ip} concentrations of compound in permeate - DAD Diode - Array Detector - DW Dry weight - HPLC High performance liquid chromatography - J_p permeate flux during extract filtration - J_w pure water flux - MF Microfiltration - MS Mass spectrometer - MW Molecular Weight - MWCO Molecular weight cut off - NF Nanofiltration - ORAC - P pressure - PEG Poly Ethylene Glycol - R_a Fouling resistance - R_i Initial resistance - R_m membrane resistance - RO Reverse Osmosis - R_t total resistance - SE Standard error - TMP Trans - Membrane Pressure - UF Ultrafiltration - UPLC Ultra High - pressure Liquid-Chromatography - UV Ultra violet - V_0 initial feed volume - V_R retention volume - VRF volume -reduction vector - μ_p dynamic - viscosity of the extract - μ_w dynamic viscosity of water

INTRODUCTION

A significant quantity of grape derivatives are generated worldwide by the wine industry. These byproducts are an important source of antioxidant molecules such as polyphenols, ranging from 2.5 to 7.8 g 100 g⁻¹ dry weight (DW) (Spigno and De Faveri, 2007). Grape byproducts contain quantities of different phenolic compounds, important for their role in plant physiology and are regarded as notable components of human nutrition. The latter idea is backed by numerous studies indicating interesting antioxidant capacity; cardioprotective, neuroprotective and anticancer (Craft *et al.*, 2012; Kähkönen and Heinonen, 2003; Quideau *et al.*, 2011; Stintzing *et al.*, 2002).

The use of ultrafiltration membrane (UF) for plant extract purification has been little reported; Tsibranska *et al.* (2011); Galanakis *et al.* (2013); Díaz-Reinoso *et al.* (2009); Santamaría *et al.* (2002) assayed different tubular polymeric membrane sequences in order to fractionate phenolics (gallic acid, catechin and gallates) recovered from defatted milled grape seeds, using acetone–water mixtures on the basis of molecular weight (MW). Díaz-Reinoso *et al.* (2009) processed to concentrate, aqueous extracts from pressed distilled grape pomace by nanofiltration (NF) membranes. The five tested ceramic NF membranes were suitable for concentration purposes. The phenolic content in retentates was increased by factors of 3–6. While Galanakis *et al.* (2013) suggested that the separation of phenolic compounds recovered from winery sludge is achievable using three ultrafiltration organic membranes (100 kDa, 20 kDa, 1 kDa). The authors established that polysulfone membranes were able to separate phenolic compounds from pectin fractions. They could not fractionate different phenolic classes and sugars (reducing or not) as they were retained even in high percentages at 100 kDa. By contrast, the application of a non-polar fluoropolymer membrane in the border of UF and NF (1 kDa) could provide a successful methodology to separate different phenolic classes. Recently Zagklis and Paraskeva (2015) proposed a purification method for the separation of grape marc phenolic compounds coupling UF (100 kDa) and NF 480 Da) with resin adsorption/desorption.

This study aims to determine the feasibility of using UF to separate and concentrate

polyphenolic compounds without utilizing any organic solvent. We have previously optimized the extraction of fermented grape pomace using subcritical water extraction (Yammine *et al.*, 2015). To realise the purification of the crude extract, several organic membranes with differential molecular weight cut off of 100 kDa to 2 kDa were tested. The performance of the process in terms of retention, permeate flux and transmembrane pressures (TMP) in a UF apparatus was evaluated. Conditions consisted of constant temperature and circulation flow rate. Retention percentages of phenolic acids, stilbenes, anthocyanins, monomeric flavan-3-ols and polymeric flavan-3-ols were obtained with different membranes.

MATERIALS AND METHODS

1. Subcritical water extraction

In the extraction system, a HPLC pump (Shimadzu LD-AC10) was used for deionized water delivery and controlling the pressure of the system. A pressure transducer (Davidson, Druck) and thermocouple (Caveland Electric) were installed in the custom-made high-pressure vessel to monitor both pressure and temperature of the system. Extract was collected in an inerted vessel after passing through an ice bath. In each run, red Dunkelfelder pomace (70g), supplied by the university of Changins, was loaded into the high-pressure vessel, which can contain 325 cm³ of material. The vessel was placed in an oven at a predetermined temperature of 150 °C. The outlet valve of the extraction vessel was then closed and the system was pressurized to the desired 25 bars at a constant flow rate. The water flow rate was adjusted at 20 mL/min using a metering valve on the HPLC pump. After 3 L of extraction, the solution which was collected in an inerted sampling vessel and the pomace were then stored at 4 °C for further analysis and membrane separation.

2. Experimental analysis and membranes

UF experiments were performed in a pilot unit (Figure 1), equipped with a Sepa® CF II Membrane Cell System (GE Osmonics, Minnetonka, MN, USA) featuring an effective membrane area of 0.0153 m². The temperature was maintained at 20 ± 0.5 °C by using a thermal bath. Permeate flux was determined at a 2 m s⁻¹ of crossflow velocity, by weighing the amount of permeate with a balance, connected to a computer. Weight and pressure values were

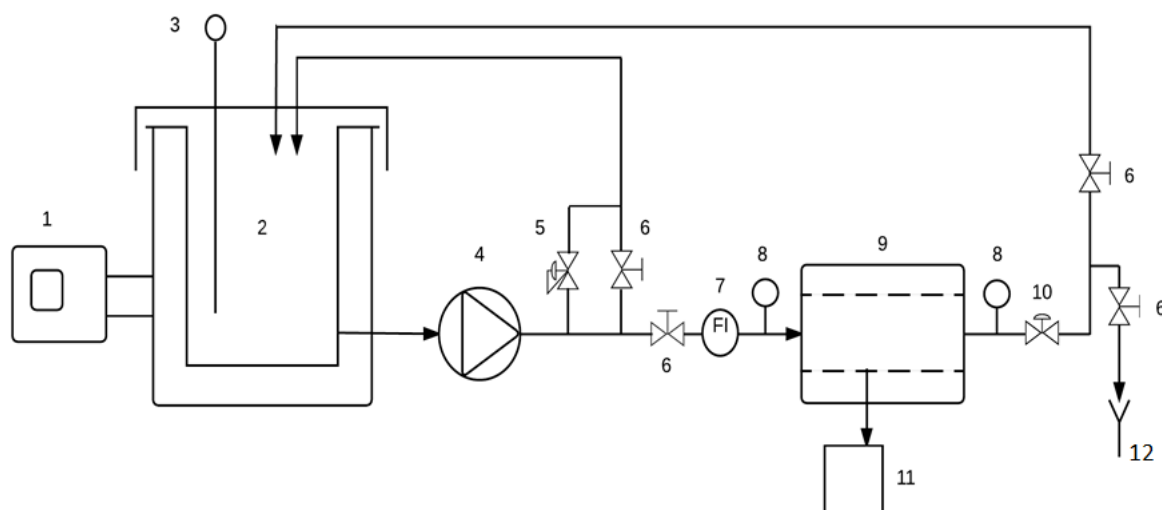

FIGURE 1. Flow sheet of the experimental apparatus: 1. thermal bath, 2. feed tank, 3. temperature probe, 4. high-pressure pump, 5. security valve, 6. valves, 8. pressure probes, 9. membrane cell system, 10. valves,, 11. pressure control valve, 12. balance

recorded every second by an electronic system. The eleven commercial UF flat-sheet membranes were acquired from the manufacturers; Table 1 lists their characteristics. Only new membranes were used throughout the experiment.

3. Membrane process

The membranes were preconditioned with deionized water for 60 min at 20 °C using transmembrane pressure 5.10^5 Pa and 2 ms^{-1} of crossflow velocity. Water permeability was determined for four pressures between 105 Pa and 5.10^5 Pa during the last 20 min of preconditioning using the slope of the plot of permeate weight recovered, against time.

Immediately after preconditioning, a trial with grape pomace extract was filtered. The filtration experiments were conducted at the natural pH of the extract (3.7) in tangential crossflow mode with the feed stream flowing tangential to the membrane surface. The operating method was batch concentration mode; the retentate or concentrate stream was flowed back to the feed tank, while the permeate stream was collected separately and not recirculated to the storage vessel. The initial volume of extract treated was 2L in all cases and the flow rate was fixed at $v=2 \text{ m s}^{-1}$, corresponding to a flow rate of 29.70 mL s^{-1} . The temperature was set at a constant 20°C. The transmembrane pressures tested for each membrane were 1, 2, 3, 4 and 5.10^5 Pa.

The duration of each experiment varied according to the desired value of volume reduction factor (VRF) to be reached. This parameter is defined by:

$$VRF = \frac{V_0}{VR}$$

where V_0 is the initial feed volume and VR is the retention volume, that is the extract volume remaining in the storage vessel ($VR = V_0 - V_P$).

For the MWCO membranes ranging from 50 kDa to 100 kDa the permeate flux was expressed at a $VRF = 10$, which implies 1.8 L of permeate was obtained. While for lower MWCO membranes of 20 to 2 kDa, due to lower filtration fluxes, permeate flux was expressed at a $VRF = 2$ and a retentate 1L was obtained. The samples of raw material and permeate collected were immediately frozen and kept at -20 °C until analyzed. To measure membrane selectivity for a solute, the observed retention was calculated, as shown in the following expression:

$$Ri = \left(1 - \frac{Cip}{Cif}\right) \cdot 100$$

where Ri is the observed retention of compound i (%) and Cip and Cif are the concentrations of compound in permeate and feed (mg L^{-1}), respectively.

According to Darcy's law, total hydraulic resistance (Rt) during UF of grape pomace extract was calculated as follows:

TABLE 1. Characteristics of the tested ultrafiltration (UF) membranes (manufacturer data)

Designation Manufacturer	Polymer type	Nominal molecule weight	Percentage Rejection	Maximum Pressure (°C 10 ⁵ PA)	Recommended pH range	Maximum temp.	Contact angle
FS40PP	Alfa laval	Fluoropolymer	100000	10	1-11	60	110*4
GR40PP	Alfa laval	Polysulfone	100000	10	1-13	75	70*3
MW	GE Osmonics	Polyacrylonitrile	50000	7	1-11	50	70*3
GR51PP	Alfa laval	Polysulfone	50000	10	1-13	75	70*3
GR61PP	Alfa laval	Polysulfone	20000	10	1-13	75	70*3
PW	GE Osmonics	Polyethersulfone	10000	13	1-11	50	60*3
GR81PP	Alfa Laval	Polyethersulfone	10000	10	1-13	75	60*3
PT	GE Osmonics	Polyethersulfone	5000	3,4	1-11	50	60*3
GK	GE Osmonics	Thin Film ⁴	3500	5,2	1-11	50	66*3
GH	GE Osmonics	Thin Film ⁴	2000	10	1-11	50	66*3
GR95PP	Alfa laval	Polyethersulfone	2000	10	1-11	65	60*3

$$R_t = \frac{\Delta P}{J_p \cdot \mu_p}$$

Where J_p is the permeate flux, ΔP is the transmembrane pressure applied and μ_p is the dynamic viscosity of the product.

To assess resistance due to fouling and/or concentration / polarization phenomena, the intrinsic membrane resistance (R_m) was measured during filtration of pure water, using clean membranes (hydraulic permeability). Intrinsic membrane resistance was calculated as follows:

$$R_m = \frac{\Delta P}{J_w \cdot \mu_w}$$

Where J_w ($\text{m}^3 \text{s}^{-1} \text{m}^{-2}$) is the pure water flux, ΔP (Pa) is the transmembrane pressure applied and μ_w (Pa s^{-1}) is the dynamic viscosity of water.

Resistance created by fouling and/or concentration / polarization phenomena (R_a) during grape pomace extract filtration was calculated as the difference between total resistance (R_t) obtained during the filtration experiment and membrane resistance (R_m):

$$R_a = R_t - R_m$$

4. Chemical analysis

4.1 pH, total sugars, polysaccharides

pH values of feed samples were measured with a digital pH-meter (Thermo Scientific™ Orion™ Star A324). The total sugar content was determined by the anthrone method (Trevelyan *et al.*, 1952) and expressed as glucose equivalents (GE).

Total polysaccharides were determined using the modified Usseglio Tomasset method (Usseglio Tomasset, 1976) based on the precipitation of the polysaccharides with ethanol.

4.2 Proteins

Protein content was determined by EZQ® protein quantitation kit (Invitrogen) following the manufacturer's instructions. The calibration curve was built using serial dilution from 0 to 250 mg/L of thaumatin from *Thaumatococcus daniellii* (Sigma Aldrich, France). Fluorescence measurements were taken using excitation/emission settings of 485/590 nm with a FLUOstar Omega microplate reader (BMG LABTECH, France).

4.3 Total polyphenols content

The total phenolic content was spectrophotometrically measured according to a modified Folin Ciocalteu method to be applied in 96-well microplates. Stock solutions (10 mg/mL) of the grape pomace extracts were prepared in EtOH/H₂O (25:75, v/v) and a microplate spectrophotometer (MultiSkan Spectrum, Thermo Scientific) was used for the incubation and measurement. Each well was filled with 184 µL of distilled water and 24 µL of the sample solution, followed by 12 µL of the Folin Ciocalteu reagent and 30 µL of 20 % (w/v) Na₂CO₃ solution. Prior to the measurement of the absorbance at 765 nm, the mixture was incubated for 1h under dark conditions at 25 °C. Gallic acid was used as a standard for calibration. Results, expressed as milligrams of gallic acid per 100 g of grape pomace sample (on a dry matter basis, dried matters), were a mean of six determinations. Total polyphenol content was measured to evaluate the influence of each operating parameter on the total rejection of each membrane.

4.4 Antioxidant activity – ORAC

The oxygen radical absorbance capacity analysis was applied by using 96-well fluorescence microplates. The reaction was carried out in phosphate buffer (75 mM, pH 7.4). In the order, 30 µL of the pomace extract solution, 180 µL of fluorescein (117 nM final concentration) and 90 µL of AAPH (40 mM), added to each well. The mixture was shaken and allowed to stand for 1.5 h at 37 °C. Fluorescence was recorded every minute during this period at excitation and emission wavelengths of 485 and 530 nm, respectively. Simultaneously on the same microplate, a blank sample (phosphate buffer replaced the sample) and Trolox calibration solutions (1–40 µM) were also performed ($R^2 = 0.983$). The area under the curve (AUC) was calculated for each extract sample by integrating their relative fluorescence curves. By subtracting the AUC of the blank, the net AUC of the pomace extracts was calculated and correlated with Trolox concentrations.

4.5 Phenolic classes

UPLC analyses were performed in an Agilent 1260 apparatus consisting in an autosampler module, a degasser, a binary pump, a column heater/selector and a UV–visible DAD detector (Agilent Technologies, USA). Chromatographic

separation was performed on an Agilent C18 (2.1 mm x 100 mm, 1.8 µm). Anthocyanins were eluted with a flow rate of 0.4 mL/min and a gradient of water/acetonitrile/formic acid (87/3/10; solvent A) and water/acetonitrile/formic acid (40/50/10; solvent B) according to the following gradient program (v/v): 0 min 94% A 6% B, 15 min 70%

A 30% B, 30 min 50% A 50% B, 35 min 40% A 60% B, 40 min 35% A 65% B, 41 min 100% B isocratic for 5 min. Detection was performed at 518 nm. Other polyphenols were eluted with a flow rate of 0.4 mL/min and a gradient of water/formic acid (99.9/0.1; solvent A) and acetonitrile/formic acid (99.9/0.1; solvent B) according to the following gradient program (v/v): 0 min 93% A 7% B, 15 min 86% A 14% B, 40 min 65% A 35% B, 44 min 50% A 50% B, 54 min 30% A 70% B, 55 min 100% B isocratic for 5 min. Detection was performed at 280 nm for flavanols, 306 nm for stilbenes, 310 nm for coumaric acid derivatives and 370 nm for flavonols. Phenolic compounds were eluted with a flow rate of 1 mL/min and a gradient of water/formic acid (99.9/0.1; solvent A) and acetonitrile/formic acid (99.9/0.1; solvent B) according to the following gradient program (v/v): 0 min 70% A 30% B, 18 min 65% A 35% B, 46 min 20% A 80% B, 47 min 100% B isocratic for 5 min.

This HPLC was coupled to an Esquire 3000+ ion trap mass spectrometer using an ESI source from Bruker – Daltonics (USA). Nitrogen was used as a drying gas. ESI-MS parameters: positive mode, nitrogen flow rate 10L/min, nebulizer pressure 0.275 10⁵Pa, drying gas temperature 365 °C, HV capillary –3700 V, end plate offset –500 V, capillary exit 111.2 V, skimmer 40 V and trap drive 45.9; negative mode, nitrogen flow rate 10 L/min, nebulizer pressure 0.172 10⁵Pa, drying gas temperature 350 °C, HV capillary +3400 V, end plate offset –500 V, capillary exit –115.3 V, skimmer –40 V and trap drive 42.9.

Identification of phenolic compounds was achieved using their UV/vis spectra, ion mass and MS/MS fragments using available standards. The quantification of the detected anthocyanins was obtained using a standard calibration curve of malvidin-3-O-glucoside in increasing concentration between 5 to 200 mg/L. The results were expressed as mg of malvidin-3-O-glucoside specific compound per L of extract and the data represent the means of three

TABLE 2. Characteristics of the winery pomace extracts used as feed liquids.

Molecules	Unit	Extract
Proteins	mg/L	238,0 ± 34,7
Pectins	mg/L	864,2 ± 32,4
Sugars	mg/L	4096,4 ± 216,9
Total polyphenols	mg/L	3309,1 ± 366,4
Phenolic acids	mg/L	243,7 ± 90,3
Anthocyanins	mg/L	153,6 ± 12,4
Stilbenes	mg/L	21,3 ± 2,3
Monomeric Flavan-3-ols	mg/L	76,3 ± 3,8
Polymeric Flavan-3-ols ORAC	mg/L	153,0 ± 8,5
	μmol Trolox g-1	192,2 ± 14,0

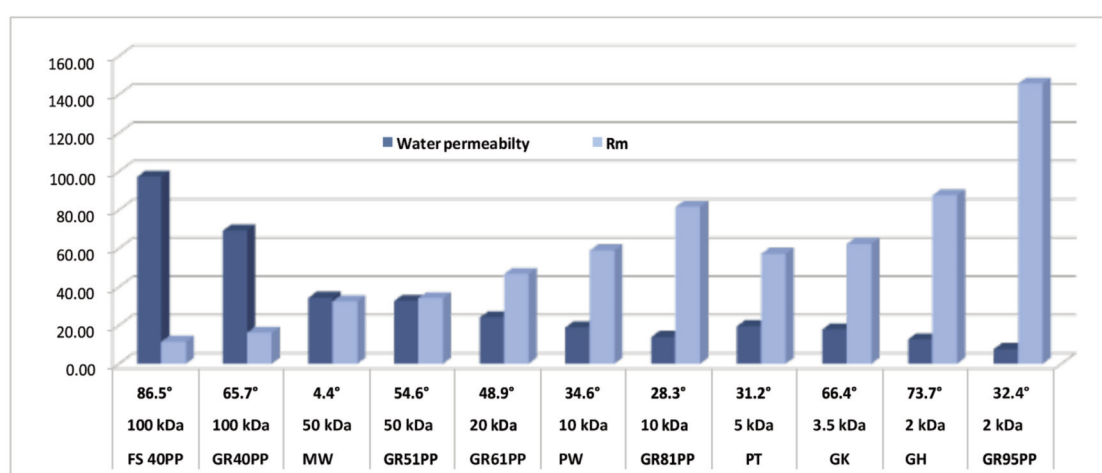
**FIGURE 2.** Hydraulic permeability ($Lm^{-2}h^{-1} \cdot 10^{-5} Pa$) and membrane resistance (R_m) $10 m^{-1}$ to water and contact angle for the ultrafiltration membranes ($T = 20\text{ }^{\circ}C$).

instrumental replicates \pm SE. Each compound was analyzed to identify a potential affinity between membrane and specific polyphenols.

RESULTS AND DISCUSSION

1. Grape subcritical extract composition

The main components and antioxidant capacity of the grape pomace extract used as raw material for the UF experiments are presented in Table 2. The extract presents relatively low contents of proteins and high levels of acidity, polysaccharides, polyphenols and anthocyanins.

2. Membrane performance

2.1. Water permeability determination

The hydraulic permeability L_p is an intrinsic feature of a non-fouled membrane that must be

determined. Prior to the general filtration experiments of the grape pomace extracts, several filtration tests of pure water were carried out with each one of the filtration membranes selected, with the aim of measuring the evolution of the water permeate flux (J_w) with the variation of TMP. The results obtained showed the permeability that is the slope of J_w in function of TMP. R_m could also be determined.

After regression analysis, the following values were deduced, ranging from 7.8 to 97.4 $L h^{-1} m^{-2} 10^5 Pa^{-1}$, for the GR95PP (2 kDa) to FS40PP (100 kDa) membranes. For the utilized UF membranes, the expected increase in the hydraulic permeability occurred among membranes of the same nature; larger pore sizes or MWC0 lead to higher pure water flux.

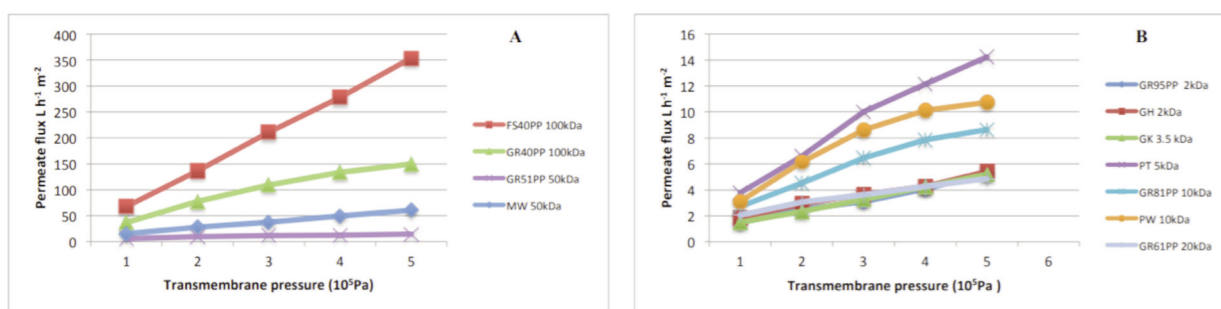

FIGURE 3. Permeate fluxes during ultrafiltration of grape pomace extract with respect to transmembrane pressure for 11 different membranes: A (VRF=10) B (VRF=2)

3. Influence of operating conditions on the permeate flux

Figure 3 presents the permeate fluxes against transmembrane pressure (1 to $5 \cdot 10^5$ Pa), obtained for eleven UF membranes when filtering the grape pomace subcritical water extract. These show different trends: some UF membranes (MW, FS40PP, GR40PP and GR51PP) are characterized by a steady increase of permeate flux when transmembrane pressure increases (VRF=10). These membranes have a nominal MWCO equal to 50 kDa and 100 kDa. For the same cut off the permeability depends on the membrane and varies from 9 to $70 \text{ Lm}^{-2}\text{h}^{-1} \cdot 10 \text{ Pa}^{-1}$. Another group of membranes, with a nominal MWCO equal to or less than 20 kDa (GR95PP, GH, PT, GR81PP, PW, GR61PP and GK), behave in a different manner; when the transmembrane pressure is increased (VRF=2), at about $5 \cdot 10^5$ Pa, the permeate flux does not correlate with the increase in pressure. This behavior is well known for UF membranes due to the fouling (cake and/or concentration polarisation) at higher pressures (Bohonak and Zydney, 2005; Kallioinen *et al.*, 2007). Membranes from GE Osmonics (i.e., GH, GK, PT and PW) presented high permeate fluxes, considering their relatively low nominal MWCOs, compared with the Alfa Laval membranes (GR95PP, GR81PP, GR61PP), made of polysulfone or polyethersulfone which have much similar nominal MWCOs. For example, a thin-film membrane (PW) from GE Osmonics, with a 10 kDa MWCO, presented a high permeation flux at $5 \cdot 10^5$ Pa ($11 \text{ Lh}^{-1} \text{ m}^{-2}$), whereas a polyethersulfone Alfa Laval membrane with a 10 kDa MWCO (GR81PP) presented one of the lowest of all permeation fluxes ($8 \text{ L h}^{-1} \text{ m}^{-2}$) under the same conditions. This result shows that, not only does transmembrane pressure

affect permeate flux, but it may also be affected by the membrane material and structure and the different interactions between solutes and membrane.

The fouling resistance (R_f) calculated for all UF membranes at different transmembrane pressures tested, is shown in Figure 4. Fouling resistance (R_f) includes intrinsic membrane fouling resistance, fouling layer resistance and resistance due to concentration polarization phenomena and/or gel layer formation (Bernat *et al.*, 2009; Butylina *et al.*, 2006). As the transmembrane pressure increases, fouling resistance increases for all UF membranes tested. When transmembrane pressure varies from 1 to $5 \cdot 10^5$ Pa, R_f increases up to 2 times, depending on the membranes. Contact angle was considered for the differentiation between a hydrophilic and a hydrophobic membrane, which influences the membrane affinity to the molecules in the filtration extract. The values presented in Table 1 indicate that the MW membranes present a highly hydrophilic surface, FS40PP membranes present a hydrophobic surface, while the remaining membranes are relatively hydrophilic. The resistance due to fouling and/or polarization was calculated, using Eq. (4); it represented at least 80% of total resistance in all cases. For the higher MWCO membranes ($>50 \text{ kDa}$), with the exception of the MW membrane, no correlations were observed between fouling resistance (R_f), the nominal MWCO and the contact angle. The structure of the membrane, nature of materials and the different interactions most likely explain the differences.

4. Retention of compounds

Table 3 presents the retention values of total protein, pectin, sugars, total polyphenols and different families of polyphenols for UF

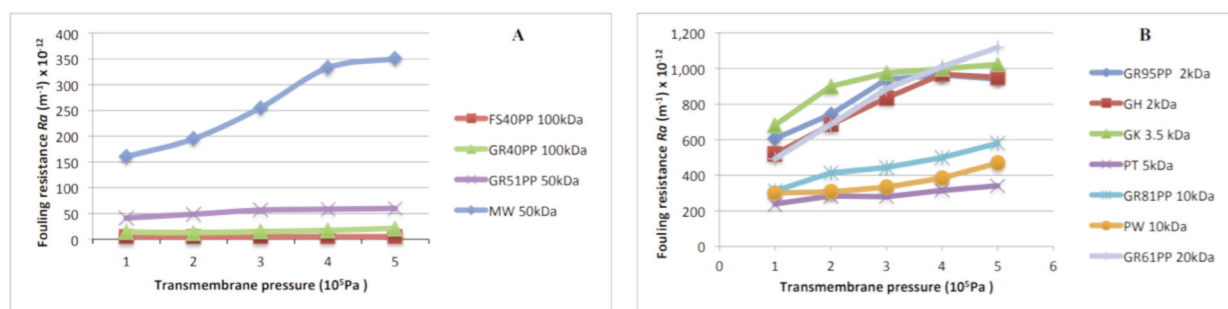

FIGURE 4. Evolution of fouling resistance for ultrafiltration membranes tested: GE Osmonics and Alfa Laval membranes: A (VRF=10) B (VRF=2)

membranes extracted at 5.310 Pa of pressure. The different compounds showed various retention percentages that were dependent on the MWCO and the type of membranes. Taking into consideration the two 50 kDa membranes, proteins showed a lesser retention with the MW membrane (21%) than the GR51PP (41%). The contact angle shown in Table 1 indicates that Ultrafilic are less hydrophobic than polysulfone. The more hydrophilic membrane result in a higher retention of proteins and a lower retention of polysaccharides (Figure 2). The membrane fouling is more important for the MW membrane (Figure 4A); this may explain the higher retention of molecules. It could be assumed that the macromolecules are responsible for membrane fouling. The membranes MWCO also influence retention of different families of molecules. Pectin results indicated highest retention values on 20 kDa membranes (72%) compared to high MWCO membranes (\approx 40% with 50 kDa).

With the exception of the membrane MW whose behavior differs, retention increases as the MWCO decreases for the three families of compounds: proteins, pectins and polymeric flavan-3-ols. Thus, the retention is a function of MWCO when it comes to large MW molecules compared to molecules of a lower MW. For phenolic acids and anthocyanins, retention becomes dependent on MWCO from 10 kDa and up to 2 kDa. Above 10 kDa, retentions are generally more important. It should be noted that the membranes of which the MWCO is larger than 10 kDa are mainly polysulfone; membranes of MWCO less than or equal to 10 kDa are polyethersulfone or thin film. The physico-chemical interactions between the compounds and polysulfone may explain the observed retention. The stilbenes and monomeric flavan-

3-ol are retained similarly on different ultrafiltration membranes tested. Sugars showed variable retention between 12 and 51 %. Total phenols showed retentions similar to those of sugars, especially in the case of more hydrophilic polysulfone membranes 54 %. These results are in accordance with Markouli *et al.* (2015), where authors have shown that for these families of molecules, separation, initial fouling and membrane resistance due to solute polarity seem to play a more important role in the separation process examined compared to MWCO.

5. Retention of macromolecules

5.1 Retention of polysaccharides

The retention of the polysaccharides and initial fouling and membrane resistance due to these molecules are believed to result from a combination of the solutes polarity and the molecular weight cut off of the membrane. The results of the current study confirm this hypothesis, depending on the material used coupled with high percentage retention of polar solutes having MW < 2 kDa. The fouling tendency of polysaccharides is less strong than proteins, but can still lead to significant flux reductions; the hydrophilic macromolecular solutes can bind to less hydrophilic membrane surfaces (Susanto and Ulbricht, 2005, 2007).

5.2 Retention of proteins

Together with amino acids and peptides, proteins constitute the main components of the nitrogenous fraction of pomace and they are essential for fermentation (Marangon *et al.*, 2011; Marangon *et al.*, 2012). This study focused on proteins, due to their negative effect on extract filtration (El Rayess *et al.*, 2012). Wines may have variable protein concentrations of up

TABLE 3. Retention coefficients (%) obtained for several parameters of subcritical grape pomace extracts as a function of different ultrafiltration membranes.

Membrane	FS40PP 100kDa	GR40PP 100kDa	MW 50kDa	GR51PP 50kDa	GR61PP 20kDa	PW 10kDa	GR81PP 10kDa	PT 5kDa	GK 3.5kDa	GH 2kDa	GR95PP 2kDa
Proteins	64,7 ± 4	41,2 ± 6	21,4 ± 2	57,7 ± 0	62,3 ± 8	79,4 ± 4	84,2 ± 0	89,2 ± 9	90 ± 9	94,3 ± 7	94,8 ± 8
Pectins	21,3 ± 1	29,4 ± 4	43,3 ± 3	37,5 ± 4	72,2 ± 5	77,1 ± 0	79,3 ± 1	80,7 ± 4	79,4 ± 6	93 ± 8	91,3 ± 4
Sugars	17 ± 8	12,1 ± 7	34,1 ± 8	29,2 ± 3	26,7 ± 7	21,9 ± 2	30 ± 2	26,6 ± 0	17 ± 7	48,3 ± 6	36,5 ± 3
Total polyphenols	10,1 ± 1	54 ± 6	68,8 ± 5	62,3 ± 1	64,7 ± 5	48,3 ± 8	39,9 ± 3	29 ± 7	48,5 ± 1	56,8 ± 0	45,5 ± 3
Phenolic acids	34,4 ± 6	50,4 ± 6	74,2 ± 5	55,9 ± 9	54,7 ± 5	54,4 ± 10	46 ± 4	49,8 ± 3	62,7 ± 7	64,2 ± 6	69,4 ± 9
Stilbenes	52 ± 9	61,4 ± 5	75,5 ± 5	69,1 ± 2	59,7 ± 9	72,6 ± 1	72,1 ± 9	70,9 ± 4	67,5 ± 2	74,4 ± 9	74,1 ± 7
Monomeric Flavan-3-ols	44,3 ± 3	63,3 ± 4	71,3 ± 1	67,4 ± 1	60,6 ± 7	10 ± 6	63,4 ± 1	43 ± 3	41,3 ± 9	57,7 ± 7	54,8 ± 8
Polymeric Flavan-3-ols	21,5 ± 1	44,4 ± 7	56,2 ± 1	42 ± 1	51,8 ± 8	64 ± 1	69,7 ± 0	76 ± 6	77,9 ± 3	85,4 ± 8	88,1 ± 1
Anthocyanins	12 ± 4	43,4 ± 9	71 ± 6	57,6 ± 2	64,2 ± 6	27,4 ± 7	26,9 ± 5	38,4 ± 8	58,4 ± 10	56,7 ± 4	61,6 ± 8

to a few hundred (10-500) mg/L, mainly originating from grapes (Ribéreau-Gayon *et al.*, 2006). The polarity of the grape protein molecules is highly variable. To our knowledge no work has been done to characterize their polarity and membrane interaction. The current study has shown that retention of the proteins is due to the molecular weight cut off of the membrane.

5.3 Retention and fractioning of polyphenols

Phenolic compounds have a much more important affinity for membranes than the polysaccharides and there are both quantitative and qualitative differences between the different materials tested. Retention is expected to be governed by the molecular size and the specific structural characteristics of each solute. This could explain the much broader variation of retention percentages observed. For instance, the larger and less polar components (i.e. pectin, proteins) would be able to come close to the membrane surface and pass occasionally through the pores, resulting in moderate retention percentages at MWCO > 50 kDa. In contrast, the smaller and more polar molecules (i.e. Phenolic acids, stilbenes and sugars) could come even closer to the membranes surface, leading to local concentration, polarisation and increased rejection percentages of 60 %. A partial adsorption of the more polar molecules onto the membrane surface cannot be excluded. In every case, it is important to state that the more hydrophilic polyethersulfone showed a selective separation concerning the polarity of particular compounds and their concentration in the feed. These characteristics could lead to an effective enrichment of phenolic classes in different streams I.e. phenolic acids against polymeric flavan-3-ols or stilbenes against anthocyanins, as the retention of the first class was almost 2-fold. It is observed here that a thin film UF membrane (2 kDa) could be employed to separate different phenolic classes like monomeric, polymeric proanthocyanidins and anthocyanins on the basis of polarity and MWCO. Enriched concentrates in polymeric proanthocyanidin derivatives could be utilized as antioxidants in foodstuff, while lower permeates rich in proanthocyanidins and anthocyanins could be used as flavourings and colourants respectively.

CONCLUSION

The current study suggests that the purification of phenolic compounds recovered from grape extract is possible using UF. The multiple membranes were effective in separating phenolic compounds from pectin and protein fractions, but they could not fractionate different phenolic classes and sugars, as they were not retained at variable MWCO from 100 to 2 kDa. Using several membrane materials, separation was primarily affected by severe fouling phenomena due to polar solutes adsorption on membrane surface and less by sieving mechanism. The application of a thin film membrane in the border of UF and nanofiltration (2 kDa), provided an effective approach to separate different phenolic classes like monomeric, polymeric proanthocyanidins and anthocyanins on the basis of polarity and MWCO. Another proposal could be the sequential application of a fluoropolymer, polyethersulfone and thin film membranes (100, 50 and 2 kDa, respectively), aiming at clarifying proteins and pectins in the first step and the separation of polymeric and monomeric polyphenols in the second. The further purification of macromolecules and micromolecules may be done by diafiltration.

REFERENCES

- Bernat X., Pihlajamäki A., Fortuny A., Bengoa C., Stüber F., Fabregat A., Nyström M. and Font J., 2009. Non-enhanced ultrafiltration of iron (III) with commercial ceramic membranes. *J. Memb. Sci.* 334:129–137. doi:10.1016/j.memsci.2009.02.024
- Bohonak D. and Zydny A., 2005. Compaction and permeability effects with virus filtration membranes. *J. Memb. Sci.* 254:71–79. doi:10.1016/j.memsci.2004.12.035
- Butylina S., Luque S. and Nyström M., 2006. Fractionation of whey-derived peptides using a combination of ultrafiltration and nanofiltration. *J. Memb. Sci.* 280:418–426. doi:10.1016/j.memsci.2006.01.046
- Craft B.D., Kerrihard A.L., Amarowicz R. and Pegg R.B., 2012. Phenol-Based Antioxidants and the *In Vitro* Methods Used. *Food Sci. Food Saf.* 11:148–173. doi:10.1111/j.1541-4337.2011.00173.x
- Díaz-Reinoso B., González-López, N., Moure A., Domínguez H. and Parajó J.C., 2010. Recovery of antioxidants from industrial waste liquors using membranes and polymeric resins. *J. Food Eng.* 96:127–133. doi:10.1016/j.jfoodeng.2009.07.007
- Díaz-Reinoso B., Moure A., Domínguez H. and Parajó J.C., 2006. Supercritical CO₂ extraction and purification of compounds with antioxidant activity. *J. Agric. Food Chem.* 54:2441–69. doi:10.1021/jf052858j
- Díaz-Reinoso B., Moure A., Domínguez H. and Parajó J.C., 2009. Ultra- and nanofiltration of aqueous extracts from distilled fermented grape pomace. *Trends Food Sci. Technol.* 12:230–239. doi:10.1016/j.jfoodeng.2008.10.007
- El Rayess Y., Albasi C., Bacchin P., Taillandier P., Mietton-Peuchot M. and Devatine A., 2012. Analysis of membrane fouling during cross-flow microfiltration of wine. *Innov. Food Sci. Emerg. Technol.* 16:398–408. doi:10.1016/j.ifset.2012.09.002
- El Rayess Y., Albasi C., Bacchin P., Taillandier P., Raynal J., Mietton-Peuchot M. and Devatine A., 2011. Cross-flow microfiltration applied to oenology: A review. *J. Memb. Sci.* 382:1–19. doi:10.1016/j.memsci.2011.08.008
- Galanakis C.M., Markouli E. and Gekas V., 2013. Recovery and fractionation of different phenolic classes from winery sludge using ultrafiltration. *Sep. Purif. Technol.* 107:245–251. doi:10.1016/j.seppur.2013.01.034
- Galanakis C.M., Tornberg E. and Gekas V., 2010. A study of the recovery of the dietary fibres from olive mill wastewater and the gelling ability of the soluble fibre fraction. *LWT - Food Sci. Technol.* 43:1009–1017. doi:10.1016/j.lwt.2010.01.005
- Kähkönen M.P. and Heinonen M., 2003. Antioxidant activity of anthocyanins and their aglycons. *J. Agric. Food Chem.* 51:628–33. doi:10.1021/jf025551i
- Kallioinen M., Pekkarinen M., Mänttari M., Nuortila-Jokinen J. and Nyström M., 2007. Comparison of the performance of two different regenerated cellulose ultrafiltration membranes at high filtration pressure. *J. Memb. Sci.* 294:93–102. doi:10.1016/j.memsci.2007.02.016
- Marangon M., Van Sluyter S.C., Neilson K.A., Chan C., Haynes P.A., Waters E.J. and Falconer R.J., 2011. Roles of grape thaumatin-like protein and chitinase in white wine haze formation. *J. Agric. Food Chem.* 59:733–740. doi:10.1021/jf1038234
- Marangon M., Van Sluyter S.C., Robinson E.M.C., Muhlack R.A., Holt H.E., Haynes P.A., Godden P.W., Smith P.A. and Waters E.J., 2012. Degradation of white wine haze proteins by *Aspergillopepsin* I and II during juice flash pasteurization. *Food Chem.* 135:1157–1165. doi:10.1016/j.foodchem.2012.05.042
- Pap N., Mahosenaho M., Pongrácz E., Mikkonen H., Jaakkola M., Virtanen V., Myllykoski L., Horváth-Hovorka Z., Hodúr C., Vatai G. and Keiski R., 2010. Effect of Ultrafiltration on Anthocyanin and Flavonol Content of Black Currant Juice (*Ribes nigrum* L.). *Food Bioprocess Technol.* 5:921–928. doi:10.1007/s11947-010-0371-z

- Quideau S., Deffieux D., Douat-Casassus C. and Pouységu L., 2011. Plant polyphenols: chemical properties, biological activities and synthesis. *Angew. Chem. Int. Ed. Engl.* 50:586–621. doi:10.1002/anie.201000044
- Rai P., Majumdar G.C., Jayanti V.K., Dasgupta S. and De S., 2006. Alternative pretreatment methods to enzymatic treatment for clarification of mosambi juice using ultrafiltration. *J. Food Process Eng.* 29:202–218. doi:10.1111/j.1745-4530.2006.00058.x
- Ribèreau-Gayon P., Dubourdieu D., Donèche B. and Lonvaud A., 2006. *Handbook of enology, the microbiology of wine and vinifications* (Vol. 1). John Wiley & Sons. doi:10.1002/0470010363
- Santamaría B., Salazar G., Beltrán S. and Cabezas J.L., 2002. Membrane sequences for fractionation of polyphenolic extracts from defatted milled grape seeds. *Desalination* 148:103–109. doi:10.1016/S0011-9164(02)00661-6
- Spigno G. and De Faveri D.M., 2007. Antioxidants from grape stalks and marc: Influence of extraction procedure on yield, purity and antioxidant power of the extracts. *J. Food Eng.* 78:793–801. doi:10.1016/j.jfoodeng.2005.11.020
- Stintzing F.C., Stintzing A.S., Carle R., Frei B. and Wrolstad R.E., 2002. Color and Antioxidant Properties of Cyanidin-Based Anthocyanin Pigments. *J. Agric. Food Chem.* 50:6172–6181. doi:10.1021/jf0204811
- Susanto H. and Ulbricht M., 2005. Influence of ultrafiltration membrane characteristics on adsorptive fouling with dextrans. *J. Memb. Sci.* 266:132–142.
- Susanto H. and Ulbricht M., 2007. Photografted thin polymer hydrogel layers on PES ultrafiltration membranes: characterization, stability, and influence on separation performance. *Langmuir.* 23:7818–30. doi:10.1016/j.memsci.2005.05.018
- Tsibranska H., Peev G.A. and Tylkowski B., 2011. Fractionation of Biologically Active Compounds Extracted from Propolis by Nanofiltration. *J. Membr. Sci. Technol.* 01:1–5. doi:10.4172/2155-9589.1000109
- Ulbricht M., Ansorge W., Danielzik I., König M. and Schuster O., 2009. Fouling in microfiltration of wine: The influence of the membrane polymer on adsorption of polyphenols and polysaccharides. *Sep. Purif. Technol.* 68:335–342. doi:10.1016/j.seppur.2009.06.004
- Usseglio-Tomasset L., 1976. Les colloïdes glucidiques solides des moûts et des vins. *Connaissance Vigne et Vin* 10 (2) 193-226. doi:10.20870/oenone.1976.10.2.1643
- Yamine S., Brianceau S., Manteau S., Turk M., Ghidossi R., Vorobiev E. and Mietton-Peuchot M., 2018. Extraction and purification of high added value compounds from by-products of the winemaking chain using alternative/nonconventional processes/technologies. *Critical reviews in food science and nutrition*, 58(8), 1375-1390. doi:10.1080/10408398.2016.1259982
- Yamine S., Ghidossi R. and Mietton-Peuchot M., 2015. Eco-innovative extraction of polyphenols from grape by-products: Extraction by subcritical water and purification by membrane processes. *In 250th American chemical society meeting and exposition.*
- Yamine S., Rabagliato R., Vitrac X., Peuchot M.M. and Ghidossi R., 2019. The use of nanofiltration membranes for the fractionation of polyphenols from grape pomace extracts. *OENO One*, 53 (1), 11-26. doi:10.20870/oenone.2019.53.1.2342
- Zagklis D.P. and Paraskeva C.A., 2015. Purification of grape marc phenolic compounds through solvent extraction, membrane filtration and resin adsorption/desorption. *Sep. Purif. Technol.* 156:328–335. doi:10.1016/j.seppur.2015.10.01