



HAL
open science

Using conceptual graphs for clinical guidelines representation and knowledge visualization

Bernard Kamsu-Foguem, Germaine Tchunte-Foguem, Clovis Foguem

► **To cite this version:**

Bernard Kamsu-Foguem, Germaine Tchunte-Foguem, Clovis Foguem. Using conceptual graphs for clinical guidelines representation and knowledge visualization. *Information Systems Frontiers*, 2014, 16 (4), pp.571-589. 10.1007/s10796-012-9360-2 . hal-02629884

HAL Id: hal-02629884

<https://hal.inrae.fr/hal-02629884>

Submitted on 11 Jan 2022

HAL is a multi-disciplinary open access archive for the deposit and dissemination of scientific research documents, whether they are published or not. The documents may come from teaching and research institutions in France or abroad, or from public or private research centers.

L'archive ouverte pluridisciplinaire **HAL**, est destinée au dépôt et à la diffusion de documents scientifiques de niveau recherche, publiés ou non, émanant des établissements d'enseignement et de recherche français ou étrangers, des laboratoires publics ou privés.



Open Archive Toulouse Archive Ouverte (OATAO)

OATAO is an open access repository that collects the work of Toulouse researchers and makes it freely available over the web where possible.

This is an author-deposited version published in: <http://oatao.univ-toulouse.fr/>
Eprints ID: 11947

Identification number: DOI : 10.1007/s10796-012-9360-2
Official URL: Official URL: <http://dx.doi.org/10.1007/s10796-012-9360-2>

To cite this version:

Kamsu Foguem, Bernard and Tchuenté Fogueum, Germaine and Foguem, Clovis *Using conceptual graphs for clinical guidelines representation and knowledge visualization*. (2014) Information Systems Frontiers, vol. 16 (n° 4). pp. 571-589. ISSN 1387-3326

Any correspondence concerning this service should be sent to the repository administrator:
staff-oatao@inp-toulouse.fr

Using conceptual graphs for clinical guidelines representation and knowledge visualization

Bernard Kamsu-Foguem · Germaine Tchuenté-Foguem · Clovis Foguem

Abstract The intrinsic complexity of the medical domain requires the building of some tools to assist the clinician and improve the patient's health care. Clinical practice guidelines and protocols (CGPs) are documents with the aim of guiding decisions and criteria in specific areas of healthcare and they have been represented using several languages, but these are difficult to understand without a formal background. This paper uses conceptual graph formalism to represent CGPs. The originality here is the use of a graph-based approach in which reasoning is based on graph-theory operations to support sound logical reasoning in a visual manner. It allows users to have a maximal understanding and control over each step of the knowledge reasoning process in the CGPs exploitation. The application example concentrates on a protocol for the management of adult patients with hyperosmolar hyperglycemic state in the Intensive Care Unit.

Keywords Conceptual graphs · Knowledge representation · Visual reasoning · Medical protocols · Intensive care units

1 Introduction

Rationalization and optimization efforts, have gained more and more importance in most scientific sectors in recent years. The medical domain is no exception to this trend: medical organizations have been urged to simultaneously increase productivity and reduce costs without adversely affecting the quality of patient-care. One step towards these objectives is the application of commonly accepted standardized health care procedures. These procedures are called clinical practice guidelines and protocols. Protocols are used to improve quality assurance, reduce variation in clinical practice, guide data collection, better interpret and manage the patient's status, activate alerts and reminders and improve decision support (Latoszek-Berendsen et al. 2010).

Clinical guidelines and protocols should ease the information and knowledge modelling for complex diagnosis and treatment steps. However, these CGPs are usually written in free text, tables or flow chart. A formal representation of CGPs (with an underlying mathematically-precise notation which defines its semantics and provides reasoning mechanisms) is needed to allow one to reason from its representations. The formal representation should be translatable into sentences of a given logic, and reasoning in that underlying notation should correspond to deduction in this logic. Furthermore, the semantic distance between the model in the physician's mind and the CGP specification should be minimised in intensive care units (ICUs) (Argüello Casteleiro and Des Diz 2008). For that, it is useful to obtain a clear and well-defined semantics of CGPs specification expressed in a language understandable by human beings, so that it can be checked by domain experts. It should be

B. Kamsu-Foguem (✉)
Laboratory of Production Engineering (LGP), EA 1905,
ENIT-INPT University of Toulouse,
47 avenue d'Azereix, BP 1629, 65016, Tarbes Cedex, France
e-mail: Bernard.kamsu-foguem@enit.fr

G. Tchuenté-Foguem
Laboratory of Biomathematics, EA 3614,
Faculty of Pharmacy and Biology, University of Lille - North of France,
3 rue du Professeur Laguesse, BP 83, 59006, Lille Cedex, France

G. Tchuenté-Foguem
MAT Laboratory, UMI 209, UMMISCO, Faculty of Science,
University of Yaoundé I,
P.O. Box 812, Yaoundé, Cameroon

C. Foguem
Center for Food and Taste sciences (CSGA) -
UMR 6265 CNRS – UMR 1324 INRA - University of Burgundy,
9 E Boulevard Jeanne d'Arc,
21000, Dijon, France

easy for an expert of the application domain not only to enter different pieces of knowledge and to understand their meaning but also to understand the reasoning mechanisms and their results.

Intensive care medicine or critical care medicine is a branch of medicine concerned with the provision of life support or organ support systems in patients who are critically ill and who usually require intensive monitoring (Marino et al. 2006). Patients need admission to intensive care mostly if they are unable to safely maintain their own airway; have respiratory failure that does not respond to medical therapy (oxygen, bronchodilators, analgesia, antibiotics and urgent physiotherapy,...); or have a qualitative state of shock such as cardiovascular failure or vast burns, or a distributive state of shock such as the septic shock, whereas hypotension and a poor urine output or high rate of lactate do not respond to fluid challenges, or comatose (consciousness) patients (Takroui 2004). On the other hand, it is necessary to provide rigorous specifications of CGPs involved in ICUs and to increase their effectiveness, allowing a possible support of the decision making-process in clinical work (De Clercq et al. 2004). Methodologies supporting such support must be adapted to the needs and steps of the users, while answering software quality standards have long been recognized (Gardner 2004; Ward 2004).

In this paper, we discuss how using conceptual graphs for clinical guidelines and protocols representation can be applied profitably to tackle the problems of formal representation of CGPs with visual reasoning mechanisms and interoperability in intensive care units. As an application example, this paper concentrates on a formal modelling for the management of adult patients with hyperosmolar hyperglycemic state. For this reason, our work includes the following elements:

- The identification of cognitive assumptions used for the representation of knowledge needed in the clinical guideline comprehension. These assumptions play a significant role in the modelling of the guidelines. We describe the different types of knowledge that are involved in defining quality requirements of medical guidelines. Such knowledge will facilitate the understanding and usage of clinical guidelines.
- The implementation of conceptual graph (CG) representations and/or reasoning to represent medical knowledge, in particular, clinical guidelines and protocols (CGPs). In this context, we take a graph-based approach (Baget and Mugnier 2002) which is logically founded but autonomous from logics, relying on graphs and graph-theoretic operations. It enables graphical illustration of reasoning for the end-user.

This approach attempts to establish some graphical and rigorous means of reading the CGP specification or reviewing the results of an analysis that should not

require training in advanced mathematics and therein confidence in order to achieve a real improvement in medical supervision and treatment. Using conceptual graphs might be helpful, since they have a powerful structuring mechanism, express meaning in a form that is logically precise, humanly readable and have a set of reasoning mechanisms (Sowa 2000). Furthermore, the conceptual graphs language is being used in a number of medical information domains such as radiology reports representation and query (Bell et al. 1994), coronary diseases and coronarography discharge summaries (Delamarre et al. 1995), vocabularies representation (Volot et al. 1998), natural language understanding and processing (Zweigenbaum 1994), information retrieval (Chu and Cesnik 2001), medical progress notes and clinical findings representation (Campbell et al. 1994) and classification systems (Bernauer and Schoop 1998; Henry and Mead 1997). For reasoning services, it is often emphasized the usual linear and symbolic notations of first order predicate logic that can be difficult to handle and comprehend. An alternative to the symbolic notation is the development of a diagrammatic reasoning service that allows sentences that are equivalent to first order logic to be written in a visual or structural form (Dau and Eklund 2008). The innovation here is the use of conceptual graphs for clinical guidelines and protocols representation with a graph-based approach in which reasoning is based on graph-theoretic operations (Chein and Mugnier 2008), instead of relying on logical formulas like in developed previous infrastructures. Such an approach enables the language user to visually encompass all elementary logical transformation in understandable reasoning steps and in this way ensuring intuitive expert simulation at an early modelling stage.

The remainder of the paper is organized as follows: section 2 presents a literature about languages and modelling for CGPs representation. Section 3 gives the principles of the proposed approach for medical guidelines formalization. Section 4 presents the conceptual graphs formalism used throughout our work and shows the **modelling/representation** of CGPs using conceptual graphs, where a knowledge engineer and a medical domain expert are involved in the transformation process of a text CGPs into formal knowledge (conceptual graphs). Section 5 states how to apply the formalisation approach in the context of protocol for the management of adult patients with hyperosmolar hyperglycemic state and it gives **requirements specification** to describe some types of knowledge that are useful for an effective CGPs understanding and application. Section 6 presents discussion and concluding remarks about the proposed formal approach for medical guidelines representation.

2 State of the art

2.1 Languages and modelling for CGPs representation

There are multiple well known frameworks for **guideline**-based care representation, many of which address in detail, much of the aspects mentioned here. A number of methods to support the computerization of guidelines have been or are being developed by the health informatics community. Such methods employ different representation formalisms and computational techniques, for example: Rule-based (Arden Syntax (Hripcsak et al. 1994)), Logic-based (PROforma (Sutton et al. 2006)), Network-based (EON (Musen et al. 1996), PRODIGY (Purves 1998)), Workflow or Petri Nets (GUIDE (Quaglini et al. 2000), GLIF (Boxwala et al. 2004)), Hybrid approach (markup and formal with DeGeL (Shahar et al. 2004)). Different guideline-modeling formalisms exist not because they cannot be put into the same syntax (e.g., researchers created GLIF, EON, HELEN, SAGE (Tu et al. 2007) and PRODIGY, all of them guideline-modeling formalisms, in Protege-frame (Abu-Hanna et al. 2005)), but because they model different kinds of knowledge and use different algorithms (eg. solving temporal constraints in Asbru).

Some of these have well-defined syntax and semantics for the representation of CGPs (such as the GUIDE representation (Quaglini et al. 2000), DeGel project (Shahar et al. 2004), Asgaard/Asbru project (Shahar et al. 1998), EON project (Musen et al. 1996), PROforma project (Sutton et al. 2006), GLARE project (Terenziani et al. 2004), and the **ProtoCure** project (Ten Teije et al. 2006)). For instance, Asbru, EON and PROforma represent clinical goals formally and use task networks with various control mechanisms.

A few of the CGPs representation languages focus on expressive temporal representations and even validation and verification procedures. For example, the Asgaard and **ProtoCure** projects or the GLARE project which in fact include formal verification of several important properties. Within the Asgaard project, a temporal, intention-based, and sharable language called *Asbru* has been developed, which incorporates some task-specific knowledge for protocol acquisition and verification (Duftschmid et al. 2002). However, structural operational semantics rules of **Asbru** are difficult to **understand for people without a formal background**, and an Asbru representation of a CGP is usually transformed into a more formal representation (namely KIV (Balsler et al. 2000)) and then verified. The RESUME system (Shahar 1997) is as an example of using a vocabulary, and the vocabulary constructed there is focused on representation of properties of temporal entities in medical domains. Similarly, the GLARE project uses formal verifiable temporal reasoning and planning properties, and the ProtoCure project constructs formal proofs of certain types of validity and verification in Asbru guidelines.

Table 1 shows that most of guidelines representation languages are not formal enough for the purpose of our research as they often incorporate free-text elements which do not have a clear semantics. Only Asbru, EON, PROforma, and GUIDE represent goals formally and allow reasoning about them. Similarly, only Asbru and PROforma represent effects of plans and reason with them (Peleg et al. 2003). Finally, the guidelines representation languages which are completely formal are PROforma and **Asbru**. We argue that a completely formal language is needed for a well-defined specification of guideline-based decision-support services in order to facilitate sharing of tools that implement computable clinical guidelines. The reality of biomedical informatics research is that any effort will solve only part of the problem and must rely on others for other needed components. It is more important to develop methods for interoperability and interfaces than proposing to translate everything to a single formalism. Semantic incompatibility is considered as an important barrier to interoperability. The ‘semantic annotation’ (the act of attaching metadata information on the semantic content of a document) is a method to move this semantic barrier for sharing and exchanging information between two or more systems (Naudet et al. 2010). Some researchers have adopted Conceptual Graphs directly as formalism for representing annotations in different contexts (Dieng-Kuntz and Corby 2005), such as for the representation of disease processes, treatment procedures and healthcare procedures with schemata or prototypes.

2.2 Conceptual graphs (CGs) implementations in medicine

The use of Conceptual Graphs has been described in the context of medical and biomedical knowledge engineering instances. A previous work on conceptual graphs (CGs) implementation in medicine has been made by *Keith Campbell et al* (Campbell et al. 1994), in a similar way. They have developed a structured vocabulary to represent medical concepts for patient records based on SNOMED III (a terminology used by the American College of Pathologists) and conceptual graphs. Another effort of developing a vocabulary for biomedicine is the Unified Medical Language System (UMLS) (Campbell et al. 1998) that comprises a meta-thesaurus for bridging the gap between different terminologies (including SNOMED) and describing medical concepts with a unique identifier. Nevertheless, it does not intrinsically have a well-structured set of relationships between concepts which would be desired for the study of similarity effects and its complexity can pose comprehension problems for potential users (Slaughter et al. 2006). If the formal representation of clinical guidelines and protocols is couched in a notation which includes primitive concepts to solve semantic barriers, then the representation is written in such a way that the connection to different problems solving methods is possible.

Table 1 Characteristic of principal guidelines modelling languages

Guideline Models	Basic elements	Modelling Methods	Formal aspects
Asbru	Logic statements skeletal plans control structures and temporal annotations	task-specific, time-oriented and intention-based plan	formal, means to reuse existing domain-specific procedural knowledge
GUIDE	Decision trees and influence diagrams	Workflow (Petri nets for simulation)	semi- formal
DeGeL	Logic statements	Hybrid approach (markup and formal)	computerized, retrieval and enactment of Asbru-based clinical guidelines.
EON	decision-making mechanisms, control flow constructs, actions, activities, and temporal abstractions	Network-based	semi- formal
PROforma	Action, decision, enquiry, plan	Logic-based (combines logic programming and object-oriented modelling)	formally grounded in the R2L Language
GLARE	Atomic actions: query, work, decision, conclusion, temporal and structured formalism	semi- formal	
composite action: plan			
PRODIGY	Scenarios, action step, decision point	Network-based	semi- formal
Arden	Medical Logic Modules (MLMs), Time functions	Procedural and Rule-based	semi-formal
GLIF	Action, decision, clinical stage, control flow constructs	Workflow (based on the Arden Syntax with an object-oriented expression language)	semi- formal

In fact, modern terminologies (e.g., SNOMED CT and NCI Thesaurus) are being formalized using Description Logics (DLs). Since DLs and CGs are both rooted in semantic networks and logically founded, the question of their relationships has often been asked. We attempt, in particular, to provide readers with a clear understanding of those features that are common and those that are specific to each formalism: cycles, n-ary relations, and type-hierarchy for CGs; the style of symbolic, variable-free formulas, variety of constructors with different levels of expressiveness for DLs. On the one hand the most expressive DLs cannot express the whole First-Order Logic (\wedge , \exists) fragment (Borgida 1996) and there is no correspondence to the type-hierarchy of CGs in DL. On the other hand, employing negation in CGs, by means of introducing a special context, yields problems. In order to overcome these difficulties, Mugnier and Leclère have defined three projection-based ways of handling negation (closed-world negation, open-world assumption (classical negation and *intuitionistic* negation)) (Mugnier and Leclère 2007). Nevertheless, some works have pointed out the equivalence of a fragment of CGs (connected graphs with a tree-like structure, binary relations only, with one distinguished concept node as in a unary lambda-abstractions) with a subset of DLs (provided with intersections, inverse roles, a restricted version of conjunction, and existential restriction) (Baader et al. 1999). Finally, the syntactical possibilities of the graphs, including identity, graphs that contain circles, graphs that are

not connected, etc., allow graphs to be constructed that do not have counterparts in DL (Dau and Eklund 2008).

The work is done to examine whether clinicians-as-users can represent guidelines better using conceptual graphs and the proposal of conceptual graphs for formal representation of CGPs is motivated by communication, usability and formal reasoning requirements viewpoints. This paper further describes how the suggested approach is appropriate to support formal analysis and to represent graphically knowledge, logic and concepts used in CGPs. The work is done with the intention to render CGPs more user-friendly using conceptual graphs that can improve the readability of the reasoning services in its diagrammatic form. Clinicians-as-users would receive recommendations based on guideline knowledge that is represented formally by teams of medical experts and knowledge engineers.

3 Principles of the proposed approach for medical guidelines formalization

The paper deals with a methodology to make it easier for physicians to use machine-readable representations of guidelines and proposes the use of conceptual graphs to facilitate formal CGPs representation. In the proposed methodology, part of the project develops a combined knowledge and graph-theoretic operations for intensive care units (ICUs). The proposed approach for medical guidelines formalization intends

to allow the medical domain expert editor of CGPs (1) to specify the conceptual vocabulary of the domain by using concepts and relationships between these concepts, (2) to specify the axioms and properties of the domain in a graphical way and (3) to make these axioms easily operational in order to perform reasoning with conceptual graph formalism in the context of intensive care units.

In fact, conceptual graphs operations provide formal reasoning tools that allow ensuring reliability and enhance the quality of medical knowledge-based systems, which are critical factors for their successful use in real-world applications. For instance, these reasoning tools help the user to determine whether a knowledge-based system does or does not satisfy its purely formal specifications. The rest of the paper is mainly focused on the issue of the **modelling/representation of the guideline**. This is made possible by integrating the knowledge offered by medical community and the research from the fields of computer science and artificial Intelligence.

The whole motivation is to provide a formal framework used by the knowledge engineer creating the formal knowledge (conceptual graphs), the expert of the application domain, and the end-user asking the Artificial Intelligence to look for specific CGPs.

The activities through which the assessment of this approach has been carried out are the following (see Fig. 1):

- **Requirements specification:** requirements specification is basically an organization's understanding (in writing) of medical domain requirements and dependencies supplying interesting properties upon which to make a reasonable estimate of key notions of domain knowledge (Kamsu-Foguem and Chapurlat 2006). Specifications can provide us with a good basis upon which we can both define medical assumptions and help us to identify reasoning strategies in medical decision making. Identification of cognitive assumptions used for the representation of knowledge needed in clinical tasks may prove critical to the clinical guideline comprehension (Patel et al. 1994). Cognitive methods can capture the essential features of the medical processes underlying clinical reasoning and they are involved in defining some cognitive assumptions underlying clinical explanation tasks (Patel et al. 2001). These assumptions play a significant role in the modelling of the guidelines, since there is a correspondence between the concepts and categories that clinicians generate and use during clinical problem solving and the way the domain of medicine is organized (Arocha et al. 2005). For instance, one assumption specifies that although the input information may be fixed (e.g. people read the same patient report, physicians may observe the same patient), the processing (e.g. reasoning strategies and inferences) and the output (e.g. final diagnosis or pathophysiological explanation) may vary. Another assumption states that the

solution strategies and the types of inferences used during clinical problem solving are a function of domain-specific prior knowledge that a person possesses.

- **Modelling and reasoning using conceptual graphs:** conceptual graphs are used to express and process medical knowledge of a text CGPs. The domain vocabulary of the target medical domain (in intensive care units) is formalized. This vocabulary layer supports the evolution of vocabularies as it can define relations between the different concepts and expresses a community's consensus knowledge about a domain. Graph operations facilitate how to use the reasoning mechanisms in order to achieve medical knowledge analysis with the guidelines. The objective of the medical domain expert is to provide useful clinical knowledge and cognitive assumptions helping the knowledge engineer to understand medicine sufficiently to model the text CGPs. The objective of the knowledge engineer is to provide the medical domain expert with the capability to understand a collection of conceptual graphs representing the guidelines.
- **Implementation in the CoGUI framework:** the proposed methodology is implemented in the Conceptual Graphs Graphical User Interface (CoGUI). CoGUI (GraphIK 2012) is a user friendly tool for building conceptual graph knowledge bases with a semantic query mechanism as well as inference and verification services (provided by the projection operation, inference rules and constraints). The computational implementation of conceptual graphs in a Graphical User Interface, is done by the knowledge engineer who manages the vocabularies description and makes some formal reasoning. It is carried out in a close collaboration with medical domain experts who provide support for a consistent understanding of the domain, terminology, and recommendations of the guideline. Finally, the results of this transformation process is visualized and evaluated by a pluridisciplinary committee (including the knowledge engineer and the medical domain expert), in order to make some improvements.

4 Modelling and reasoning using conceptual graphs

This section is about modelling guidelines and background knowledge (section 4.2) and not about metaknowledge, and also not about how those types of knowledge will be combined. Now we will present some types of knowledge from medical guidelines that we want to represent, and later discuss them and why conceptual graphs fit so well. The domain vocabulary is formalized with hierarchically organized description concepts and relations relevant to the declarative background and guideline knowledge. For instance, procedural knowledge like ordering of actions,

Fig. 1 Proposed methodology for clinical guidelines formalization

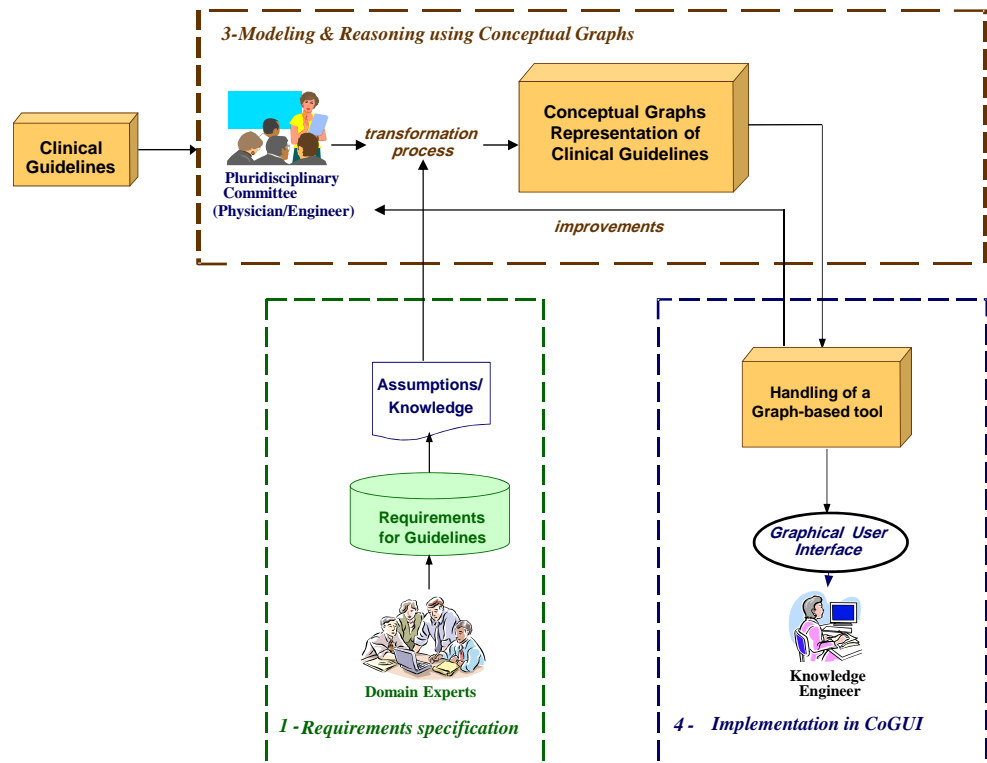

positives/negatives constraints and probabilities are described since knowledge in guidelines is time oriented, yet not very precise.

The conceptual graphs formalism has constructs for expressing nesting, loops, activities, branching, and synchronization and can express temporal constraints. It also provides operational mechanisms allowing one to reason from its representations by a **formal way**. For example, its well-defined formal foundations could support formal reasoning of a guideline model's properties. That is very important since actors are interested in the intensive care context, to model and analyse clinical data for decision making such as determining a diagnosis or monitoring the evolution of a patient (Boaz and Shahar 2005).

4.1 Conceptual graphs: a graphical knowledge representation language

The appropriate processing of medical knowledge requires the use of a knowledge representation language having a well-defined syntax and a formal semantics. We choose the conceptual graph formalism (Sowa 1984) which can be considered as a compromise representation between a formal language and a graphical language because it is visual and has a range of reasoning processes. Conceptual graph formalism (CG) is a potent support to the ontological background of any domain (Sowa and Zachman 1992) and for modeling temporal knowledge (Moulin 1997); Conceptual graphs support the modelling of probabilistic or uncertain

knowledge: an important feature of a conceptual graph system for probabilistic reasoning is that its active relations (computer codes with pragmatic intent) can glean probabilities from the outside world, either from tables, previously performed correlations or by data mining of relevant information from databases (Delugach and Rochowiak 2008). Besides, Thomopoulos et al. (2003) have introduced an extension of the conceptual graph model suitable for the representation of data which are modelled using fuzzy sets. This extension introduces a new way of comparing conceptual graphs, using a more flexible comparison of fuzzy conceptual graphs, which allows us to exploit the semantic similarity of knowledge (Buche et al. 2006).

Definition: A simple conceptual graph is a finite, connected, directed, bipartite graph consisting of conceptual **nodes** (denoted as boxes), which are connected to conceptual **relation** nodes (denoted as circles). In the alternative linear notation, concept nodes are written within []-brackets while conceptual relation nodes are denoted within ()-brackets. The concepts set and the relations set are disjoint.

A **concept** is composed of a type and a marker [<type>: <marker>], for example [Resource: stethoscope2]. The type of concept represents the occurrence of object class. They are grouped in a hierarchical structure called a concept lattice showing their inheritance relationships. The marker specifies the meaning of a concept by specifying an occurrence of the type of concept. They can be of various natures; individual, generic (symbol "*" within the marker), quantifiers, or sets (the latter by using {}-brackets within the

marker). The term “{***}” denotes a set of zero or more elements, additional cardinality constraints can be expressed, for example, by “{***}@5” (set of 5 elements) or “{***}@>4” (set of more than 4 elements). It is also possible to pair the number with a unit of measure, for example the term “@96 h” means ninety-six hours. Generally, a concept lattice is not only a tree-structure but a structure in which a same concept may have different parents modelling the pluri-axial property of some terminologies (e.g. SNOMED (Campbell et al. 1994)). It can also contain statements to express that concepts are disjoint or can define necessary and sufficient axioms and necessary implications.

A conceptual **relation** binds two or more concepts according to the following diagram:

$[C_1] \leftarrow (\textit{relation's name}) \leftarrow [C_2]$ (meaning that “C1 is related to C2 by this specific relation”).

In the analysis of clinical reasoning, the most **common relations** are dependency relations, specifically, causal, conditional, temporal, and Boolean connectives, such as alternating-OR and exclusive-OR relations (Either relations). Mugnier and Leclère (2007) have distinguished two semantics for negative relations or concepts in CGs, with respect to two logics: classical logic (with closed-world or open-world assumptions) and *intuitionistic* logic (the law of excluded middle does not hold). Although studying the logical means of handling different kinds of negation is beyond the scope of this paper which restricts itself to the technical feasibility of the candidate diagrammatic reasoning frameworks to CGPs, the definitions of properties of relationships (such as transitive, symmetric, etc.) are often included. It allows the modellers to choose from a predefined set of relations. In particular, temporal relationships are essential in our domain (i.e. ICUs) to model the temporal evolution of a patient and the temporal relationships between the different events of a patient’s clinical history (Shahar 2000). In medical domains, actions and effects are not necessarily instantaneous, but actions are considered to have temporal extensions, that is, actions can be expected to be performed in a time interval or a period of time. This characteristic may be covered by measuring temporality in a fuzzy manner (Steimann and Adlassnig 1998).

Each relation has a signature, which fixes its arity and gives the maximum types of available concepts, to which a relation of the type can relate. The sub-relation definition is sometimes necessary to provide more details in the semantic representation, and this establishes a relation lattice. In our case, these concepts and relations provide the medical domain vocabulary and the related common sense to produce a suitable human-machine interaction pattern, which helps a lot in soliciting as much patient information as possible from the user. Anyway, the concepts and relations lattice are essential and basic components of the conceptual graphs

formalism and they drive the whole other mechanisms, notably subsumption and projection.

Formal semantics: Conceptual graphs are provided with a semantics in first-order-logic, defined by a mathematical mapping classically denoted by Φ (Sowa 1984). This shows how the symbols of conceptual graphs theory map into corresponding quantities in logic theory, transforming the axioms of its domain into axioms or theorems of first-order-logic. Concept types are translated into unary predicates and relations into predicates of the same arity. Individual markers become constants. To a vocabulary V is assigned a set of formulas $\Phi(V)$ which translates the partial orders on concept types and relations: if t and t' are concept types, with $t' < t$, one has the formula $\forall x(t'(x) \rightarrow t(x))$; similarly, if r and r' are n -ary relations, with $r' < r$, one has the formula $\forall x_1 \dots x_n(r'(x_1 \dots x_n) \rightarrow r(x_1 \dots x_n))$.

An example of conceptual graph G is:

$G: [\textit{Physician: *}] \rightarrow (\textit{Agent}) \rightarrow [\textit{Medical_Plan : *}] \rightarrow (\textit{Trigger}) \rightarrow [\textit{Medical_Event: *}]$

This describes a case where a Physician (e.g. a cardiologist) is performing (e.g., concluded, ordered, or prescribed) a number of medical plans because of a number of medical events. The logical interpretation of a simple conceptual G is defined as follows: we associate a logical variable x for the concept node *Physician*, a set A of more than 1 element for the concept node *Medical_Plan* and a set B for the concept node *Medical_Event*.

$\Phi(G): \exists x, A, B, (\textit{Physician}(x) \wedge \textit{Medical_Plan}(A) \wedge \textit{Medical_Event}(B) \wedge \textit{Agent}(x, A) \wedge \textit{Trigger}(A, B)) \wedge \textit{cardinality}(A) \geq 1 \wedge \textit{cardinality}(B) \geq 0$

4.2 Formal description of the domain vocabulary with CGs

The domain vocabulary is critical to unambiguous representations of guidelines and to the sharing of guidelines in diverse clinical information system environments. Therefore, a given domain vocabulary must be modelled in a formal form in order to ensure an effective exploitation of the knowledge sources available. Thus, the use of a vocabulary in a knowledge-based system requires its transcription into an operational knowledge representation formalism. Existing medical terminologies provide the atomic units of meaning that we use to describe vocabulary representations. However, concepts used in clinical guidelines often do not precisely match the term hierarchies in standard medical terminologies. Formalising vocabulary with conceptual graphs can help in tackling this problem. It is possible to make use of two strategies to define guideline concepts from standard terminologies: (i) to use the reference terminology’s own compositional method for defining new concepts or (ii) to define a term as Boolean combinations of other terms.

Medical vocabularies have been used for representing knowledge in clinical domains, although they have been used for different purposes. In this section, some examples are mentioned. An application terminology for the paediatric domain is proposed in (Shahar et al. 1998), and another for therapy decision tasks is described in (Manjarrés Riesco et al. 2000). An application terminology was also used in the NéoGanesh system (Dojat et al. 1997) and in the Déjà Vu system (Dojat et al. 1998) to model the world into two types of entities: (1) atemporal entities, used to model the observed system, and (2) temporal entities, used for modelling the evolution. RÉSUMÉ (Shahar and Musen 1996) is another system that uses temporal terminology in medical domains.

Here, we choose the conceptual graph formalism (Sowa 1984), which provides ontological definitions and primitives to define a formal vocabulary (i.e. with a precise semantic). This vocabulary layer supports the evolution of vocabularies as it can define relations between the different concepts and expresses a community’s consensus knowledge about a domain. The concepts and relations used in the domain vocabulary must be declared in this formal vocabulary where the terms may have associated constraints (e.g. signatures for the relation types) and type definitions (e.g. definitions of necessary and/or sufficient conditions) and thus may be linked to other terms by different relations (e.g. given or calculated sub-assumption relations). Figure 2 presents the definition of the relation type called “Adverse Effect”: the concepts “Effect” and “Therapeutic_Plan” are linked by the relation “Adverse Effect” if and only if it is a harmful and undesired effect resulting from a therapeutic plan (medication or other intervention such as surgery). The description of the relation type “Adverse Effect” is logically interpreted by the following formula:

$$\exists z, t (Effect(x) \wedge Harmful(z) \wedge Undesired(t) \\ \wedge Therapeutic_Plan(y) \wedge Object(x, z) \wedge Object(x, z) \\ \wedge Agent(x, y))$$

These primitives of CGs make the properties between concept types and relations types explicit. Type definitions enable the representation of tacit knowledge and they can be used to represent the axioms and theorems of a considered domain (Fürst et al. 2003). In concrete terms, ontological knowledge of the attributes of

medical concepts and the relationships among medical concepts that go beyond the representation of basic data fields and concepts hierarchy (where the higher levels subsume or provide a context for interpretation of the lower), are modelled by these means (Wang et al. 2002). With such knowledge we can perform rigorous syntactic checks that consist of checking if a conceptual graph’s base is a “well-formed” knowledge base, respectively, to the syntactic rules of the conceptual graph model (e.g. whether an expression refers to the type definition of a concept). Conceptual graphs completely allow deploying the vocabulary of its host domain, i.e. the target application or system. With such formalism, the user always operates the vocabulary that he/she is familiar with.

The process of building the semantical mapping between the vocabulary of the guideline and the background knowledge is outside the scope of this paper. Meanwhile, it is useful to align a domain vocabulary with reference terminologies. The vocabulary description introduced here includes some concepts (disease, diagnostic and therapeutic plan, physiological states, finding (symptom or laboratory test), etc.) from UMLS meta-thesaurus. In addition, a previous work on guideline representation models has extracted common concepts from eleven different models (Wang et al. 2002). The plan (or action), decision and state are important concepts closely related to each other. A plan is a clinical or administrative task that is recommended to perform, maintain, or avoid during the process of guideline application. A decision is a selection from a set of alternatives based on predefined criteria in a guideline. A state could be either the clinical status of a patient, or an execution state that describes the situation of a guideline implementation system. The alarms triggers that warn about the state of a specific patient are registered as events of that patient and they will take part in the patient’s evolution. Thus, the resulting vocabulary includes high level concepts, such as drugs and findings about a patient, and attributes, such as units of a measurement and dosage for a drug, that medical concept and medical data may have. Consequently, it provides a coherent base in the form of a formal conceptual vocabulary, on which descriptions can be built and specifications formalized with the building blocks for formulating clinical algorithms. Indeed, a formal vocabulary should

Fig. 2 Definition of the relation type “Adverse Effect”

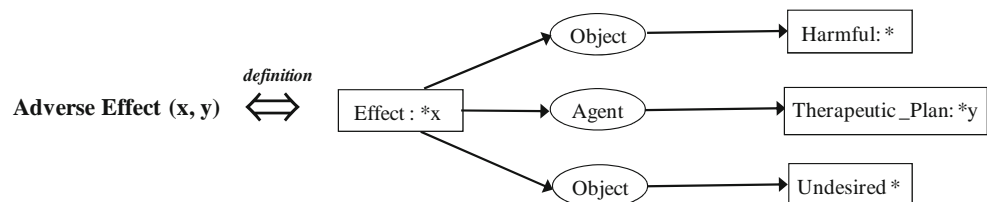

help, through inferences, to improve information search on the documents shared or accessible by the health care network actors (Dieng-Kuntz et al. 2006).

Moreover, the existence of domain vocabularies, which are the declarative conceptualizations of terminology and knowledge in the domain, requires that we should be able to distinguish knowledge from reasoning process which will use that knowledge (Sowa 2000). The implication of this modelling view of knowledge representation is the imperative need for reasoning tools to reason forms with respect to user needs and application requirements.

In the next section, we develop a modelling and analysis approach that provides a rigorous framework for formalization of guideline and background knowledge which can be used to provide a better explanation for the reasoning services.

4.3 Conceptual graph operations

Conceptual graph operations provide operational mechanisms, such as inference mechanisms allowing manipulations to which the knowledge-based system is dedicated. For instance, to perform automatic reasoning, the conceptual graph operations allow the representation of derivation rules and the effective application of these rules on to a set of facts with constraints. This is useful for specifying and sharing decision and eligibility criteria, patient state definitions, conditions, and system actions.

The fundamental operation for doing these reasoning mechanisms is the *projection*, which leads to a calculation in the specialization between two graphs. Indeed, the projection search of a graph G (request graph) in a graph H (context graph), can be seen as the inclusion search of the knowledge represented by G in H . Intuitively, the existence of a projection from a G to H means that the knowledge represented by G is contained in (or implied by) the knowledge represented by H ; and the projection operation is a global view of a specialization operation sequence (the elementary specialization operations (disjoint sum, join, restrict, relation simplify and copy) are graphically and logically defined in (Mugnier 1995)). The reasoning processes are logically founded, since projection is sound and complete with respect to deduction in first order logic (Chein and Mugnier 1992). Another essential point is that the reasoning processes operate directly on the defined pieces of knowledge and they can be visually explained to the end-user (Achour et al. 2001). Within our work, the projection operation is used to search the existence or absence of certain states/plans in a CGPs representation. Conceptual graph projection can be extended with an implementation of a depth-attenuated distance (between types in the vocabulary) or graph transformations allowing approximate search (Corby et al. 2006; Genest and Chein 2005).

There exist two other kinds of graph operations (*rules* and *constraints*) which use the projection in order to validate or transform a graph into another one. Graph operations like these are useful for a better understanding or improved reasoning about Medical Context and may have been established through the actual collaboration between medical domain experts and knowledge engineers.

4.3.1 Rules and derivation

The conceptual graph rules allow the addition of new knowledge. The graph rule is composed of a hypothesis and a conclusion, and is used in the classical way; given a simple graph, if the hypothesis of the rule projects to the graph, then the information contained in the conclusion is added to the graph.

Logical semantics: it has been shown previously that conceptual graph rules can be described by means of first-order logic augmented with the temporal operators (Baget and Mugnier 2002). A conceptual rule $R (G_1 \Rightarrow G_2)$ is a pair of λ -abstractions $(\lambda x_1, \dots, x_n G_1, kx_1, \dots, x_n G_2)$, where x_1, \dots, x_n , called connection points, enable one to link concept vertices of same label of G_1 and G_2 . The logical interpretation of a conceptual rule $R (G_1 \Rightarrow G_2)$ is defined as follows: $\Phi (R) = \forall x_1 \dots \forall x_n \Phi (\lambda x_1 \dots x_n G_1) \Rightarrow \Phi (\lambda x_1 \dots x_n G_2)$. The semantics Φ (provided in (Sowa 1984)) maps each Simple Conceptual Graph G into a first order logic formula $\Phi (G)$. When a rule is applied in forward chaining to a conceptual graph, the information of the rule is added to the conceptual graph.

Medical rules such as IF [Diagnosis: Infection] THEN [Order] \rightarrow (Object) \rightarrow [Therapy Plan : X] certainly has a dynamic interpretation : if at time interval $[t_1 t_2]$ a diagnosis of a state (e.g a qualitative state of rising fever, or rising titer of antibodies, etc.) of infection is reached, then the therapy plan X for diagnostics of infection should be started after t_2 . In (Müller 1997), some specific heuristics are defined with rules expressing knowledge which is valid only after a longer time period reflecting very individual experiences with patients. At the same time, graph rules are useful to express explicitly some temporal properties which include concurrent, cyclical and sequential actions (e.g. one performs history and physical examinations before ordering certain tests).

Due to the correspondence between conceptual graphs and RDFS (Resource Description Framework Schema) language (Yao and Eitzkorn 2006), conceptual graph rules can also be represented in SWRL (Semantic Web Rule Language (Horrocks et al. 2005)) rules and vice versa, without loss of semantic meaning. Rules expressed in formalisms like RuleML (Rule Markup Language (Park and Lee 2007)) or SWRL additionally allow one to specify actions to take, knowledge to derive, or constraints to enforce. This approach suffers from a series of **drawbacks** due to the expressiveness and visual capabilities of SWRL since, as a

representation language (built on OWL (Web Ontology Language) constructs (Argüello Casteleiro and Des Diz 2008)), it was not intended to be visually displayed as such.

4.3.2 Positive and negative constraints

A constraint defines conditions for a simple graph to be valid. It is composed of a conditional part and a mandatory part. Roughly speaking, a graph satisfies a constraint if for every projection of its conditional part, its mandatory part also projects on the graph (Baget and Mugnier 2002). We consider positive and negative constraints. A positive constraint expresses a property such as “if information A is present, then information B must also be present”. For example, a CG constraint can state that “*if a person p suffers from an allergy to a molecule m contained in a drug d, then a different drug must be prescribed to this patient*” (Magee and Bhatt 2001). A negative constraint expresses a property such as “if information A is present, then information B must be absent”. An example of negative constraint is “*a patient must not receive two incompatible treatments*”. Another example is “*if there is a therapy failure context where a situation in which the disease is not regressive (not amelioration in the state of a patient), this treatment or the current diagnosis must be reviewed*”.

As medical management is a time-oriented process, diagnostic and treatment actions described in guidelines are performed in a temporal setting. Thus, it is important to represent the formal requirements related to temporal situations (describing states, processes, events, etc.) associated with time intervals. The temporal path for a given situation is composed of a succession of time intervals and temporal relations characterizing the temporal structures (users’ perspectives and temporal localizations) in which the situation is contextualized. **Time constraints** are also represented, e.g., the delay between the injection of insulin and its effect, and the duration of its effect. Such constraints support reminder messages, since they can be used in order to permit the detection of semantic inconsistencies and incompleteness in the knowledge base according to the guideline goal and the patient specific clinical condition. These problems may be modelled and solved within a constraint satisfaction framework, by the use of filtering techniques (e.g. forward-checking and maintaining arc-consistency) that exploits the global structure of the graph (i.e. it prunes branches that do not contain solutions) in order to achieve a stronger partial consistency at a lower cost by updating only the influential matchings incrementally (Solnon 2010).

5 Applying the formalisation approach: protocol for the management of adult patients with hyperosmolar hyperglycemic state

The application example of the proposed approach is a protocol for the management of adult patients with hyperosmolar hyperglycemic state (Stoner 2005). This protocol is for patients admitted with mental status change or severe dehydration who require admission to an intensive care unit. Hyperosmolar hyperglycemic state is a life-threatening emergency manifested by marked elevation of blood glucose, hyperosmolarity, and little or no ketosis. The considered protocol provides practitioners with a clear structure of recommended actions to be taken for the control of the glucose level. With the dramatic increase in the prevalence of type-2 diabetes and the aging population, this condition may be encountered more frequently by family physicians, endocrinologists or geriatricians in the future (MacIsaac et al. 2002). Although the precipitating causes are numerous, underlying infections are the most common. Other causes include certain medications, therapeutics non-compliance, undiagnosed diabetes, substance abuse, and coexisting disease. Physical findings of hyperosmolar hyperglycemic state include those associated with profound dehydration and various neurological symptoms such as a coma. The treatment of hyperosmolar hyperglycemic state involves a five-pronged approach (Kitabchi and Nyenwe 2006): (1) fluid replacement (including vigorous intravenous rehydration and electrolyte management), (2) insulin therapy, (3) identification and treatment of the underlying and precipitating causes, (4) monitoring for complications (such as vascular occlusions and rhabdomyolysis (the rapid breakdown of skeletal muscle tissue)), and (5) prevention.

5.1 Building conceptual graphs of guideline knowledge

For the construction of a conceptual graph, we need a formal and detailed collection of nodes, relations and questions. The nodes can be contexts, medical plans or events. There are specific relations for each type of node and nested conceptual graphs enable association of any concept node with a partial internal description. This is done with the Conceptual Graphs Graphical User Interface (CoGUI) encompassing both conceptual graphs applications and conceptual graphs editor (GraphIK 2012). Basically, conceptual graph analysis has two stages:

- The first stage consists of the task analysis where a knowledge engineer and a medical domain expert are involved in the transformation process of a text CGPs into formal knowledge (conceptual graphs). In situations like this, the knowledge engineer creates some basic conceptual graphs with a clear indication of the CG

Fig. 3 Formal vocabulary (hierarchy of concept and relation types) in conceptual graph

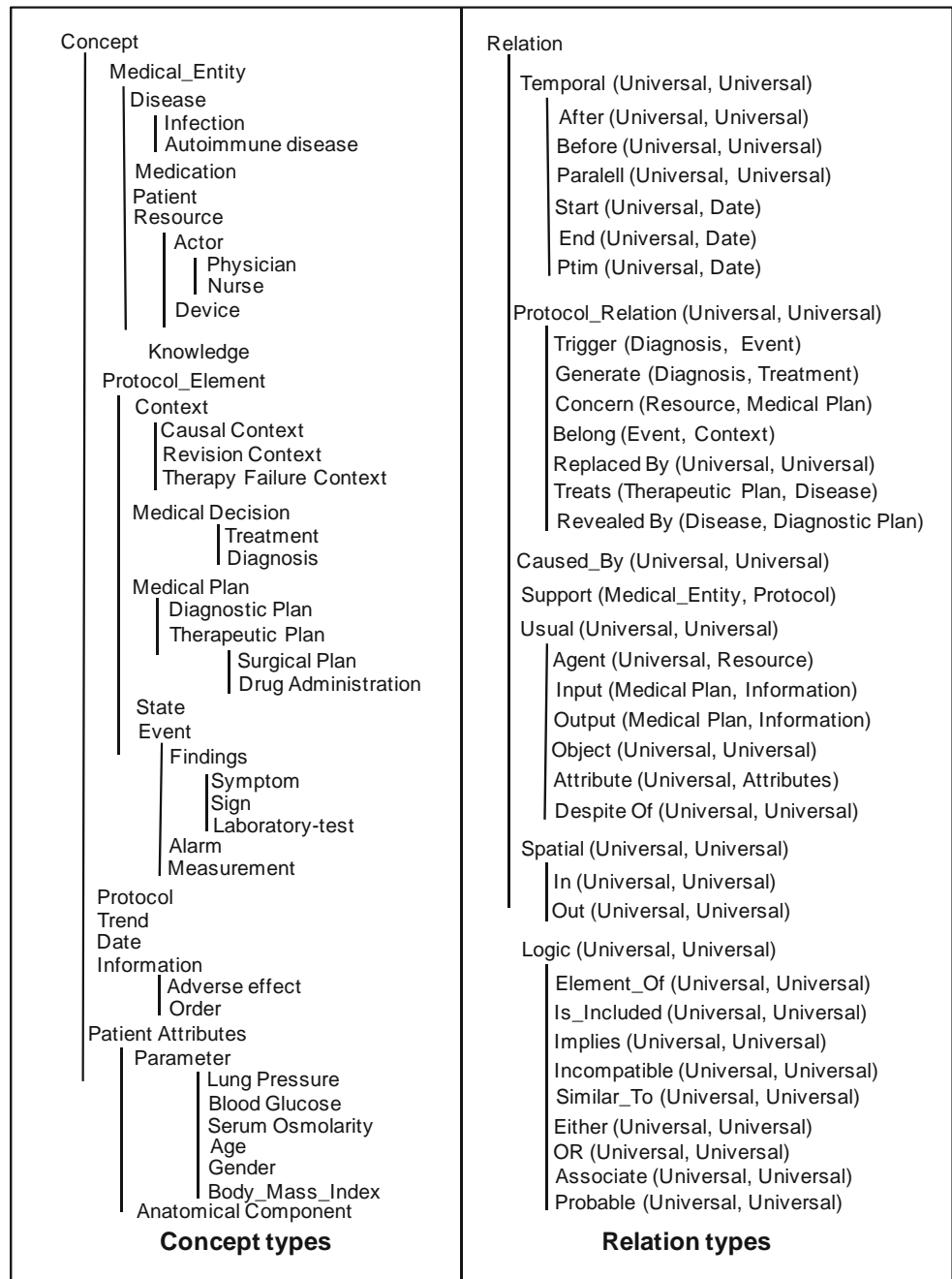

‘vocabulary’. For instance, a framework which consists of a set of conceptual graphs indicating the type of clinical context representation (diagnostic interpretation, therapeutic procedures, etc.). Four concepts coming from the formal vocabulary (Fig. 3) are used: **event**, **context**, **diagnosis** and **treatment**. Three relations are used: belong, require and generate. This generic graph can be interpreted in natural language as “every protocol application has a description which is the following: *there is an event belonging to a context, this event requires a diagnosis and the diagnosis generates a treatment. The concepts: event, context, diagnosis and*

*treatment can be described by means of nested CG ”. For example, Fig. 4 partially represents a *hyperosmolar hyperglycemic state protocol* (Stoner 2005) in conceptual graph formalism. The context’s marker is the *precipitating factors* including infections and other causes (medications, substance abuse and non-compliance). The context’s marker is the *physical findings* including profound dehydration and various neurological symptoms such as a coma. The diagnosis’s marker is *diagnostic testing* indicating marked elevation of blood glucose, or serum osmolarity. The treatment’s marker is *ADA* involving fluid replacement, insulin therapy,*

Protocol: Hyperosmolar Hyperglycemic State

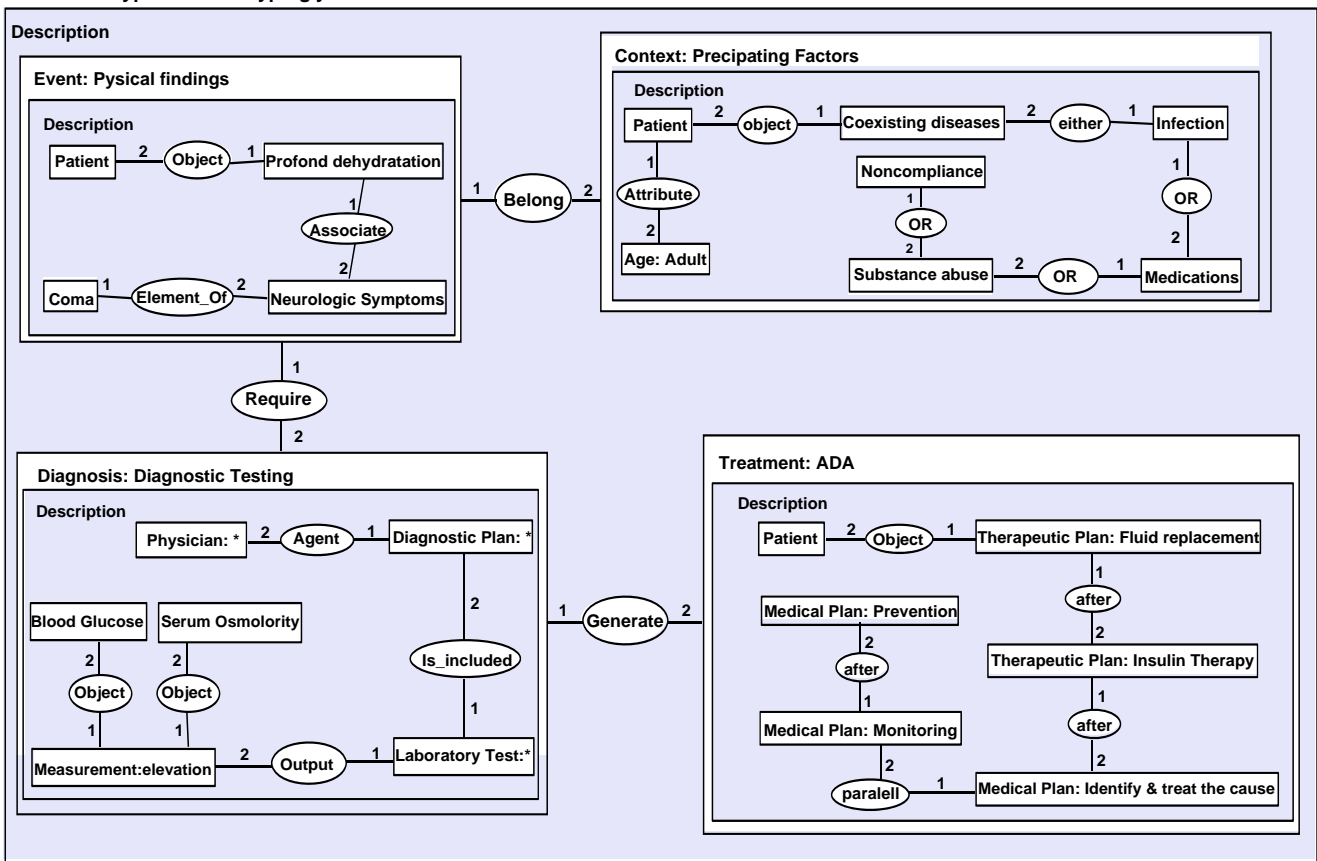

Fig. 4 Partial modelling of the hyperosmolar hyperglycemic state protocol in conceptual graph

identification and treatment of the causes, monitoring for complications, and prevention. In this figure, for binary relations, the elementary link: $C_{in} \rightarrow (rel) \rightarrow C_{out}$ will be denoted $C_{in}^1 - (rel)^2 - C_{out}$.

- In the second stage, the knowledge engineer uses the probing questions to find a deeper layer of knowledge for the graph (Carloni et al. 2009). The knowledge engineer may opt for the inclusion of a third stage in which he verifies the conceptual graph by interacting with a medical expert in order to check for missing knowledge. In such a situation, he can add facts to the fact base modelled in the conceptual graph formalism, and he can apply medical domain properties and inferential mechanisms to automatically produce implicit or new knowledge (Baget and Mugnier 2002). In our case, the verification stage is achieved by using the CoGUI Interface (GraphIK 2012), which provides functionalities for data sharing and reasoning tools for verifying and exploiting medical knowledge. As an example, if there are several alternative plans: checking a guideline for coherency means to include constraints which exclude each other because of incompatible activation conditions modelled by graph constraints. The

rule engine also could allow the user to deduce new facts resulting of a change in the logic of the guideline.

Such a protocol modelling with the conceptual graph-based tool is useful and illustrates the interest of the proposed approach to help the user to easily understand knowledge base, to visualise reasoning or decision-making processes. Indeed, the benefits of the use of computers in health care will be delivered if we design computerized medical assistants which can efficiently relieve the clinical staff of repetitive tasks and, more importantly, to really support practitioners in decision making in real time.

5.2 Knowledge requirements for characterization of hyperosmolar disease

Although medical guidelines give recommendations based on the best available evidence, **background knowledge** and **metaknowledge** (also useful for good medical practice) are usually missing from the guidelines. For example the prevention against the prescription of redundant drugs, or some advices against a prescription of a treatment that is less

effective than some alternative. Previous works (Hommersom et al. 2007) made a distinction between the different types of knowledge that are involved in defining quality requirements of medical guidelines:

- **background knowledge** concerning the (patho)physiological mechanisms underlying the disease and the way the treatment influences these mechanisms. This knowledge is distilled from medical literature (articles, books or handbooks of medicine). Insulin therapy is the treatment of decompensated diabetes mellitus; the initial phase of his management appeals continual glucose level and metabolic monitoring. For example, complex and multifactorial metabolic changes very often lead to damage and function impairment of many organs, like the blood vessels (angiopathy) or hypomagnesemia in diabetes mellitus. In particular, it is possible to represent in a conceptual graph form situations, such as the “*hypomagnesemia may be present in up to 90 percent of patients with uncontrolled diabetes*” (Stoner 2005). Unless the patient is in renal failure, administration of magnesium is safe and physiologic (Fig. 5). Besides, the degree of neurological impairment is related directly to the effective serum osmolarity (Kitabchi and Nyenwe 2006), with coma often occurring once the serum osmolarity is greater than 350 mOsm per kg (350 mmol per kg).
- **guidelines knowledge** concerning the recommended treatment in every step of the guideline and how the choice for each treatment is affected by the state of the patient. As an example, when treating diabetes with Neutral Protamine Hagedorn insulin (NPH insulin), a desirable property of the protocol (as recommended by some domain experts (Ten Teije et al. 2006)) is to distribute the morning and evening insulin doses according to the ratio 2/3—1/3. In the Fig. 6, a therapeutic plan with NPH insulin injection (at one point in time (P_{tim})) influences the state of patients by causing a context of blood glucose decreasing that starts after 2-3 hours, its pick is 4-6 hours and his duration is about 12 hours. However, there are different protocols of distribution with other kinds of insulin (Glargine insulin: once a day; Detemir insulin: once or twice a day). Other examples are conditional goals associated with guidelines in the EON guideline model (Musen et al. 1996) (e.g. if patient is diabetic, the target blood pressures are 130/80). If insulin is being prescribed to the patient suffering from

hyperglycaemia (with abnormal B-cell capacity), then an increased uptake of glucose results in the patient condition changing to normoglycaemia (formalized in Fig. 7).

- **metaknowledge** concern good practice in treatment selection and includes patterns that specify the behaviour of treatment selection, given certain patient data. Such knowledge is reviewed and revised by national public authorities and must be mapped to those of the local medical institutions. The recommendation of this knowledge becomes more efficient as clinicians’ experience with patients increases and with participation of international congress of medicine. An example is the preference of one treatment over another if it uses a smaller number of drugs and has an equal effect on the patient or if it minimizes the adverse effects on the patient (Fig. 8).

All these types of knowledge are useful during the guidelines and protocols application and clinicians can judge their contextual relevance according to a clinical process evolution and patient’s management. Indeed, incompleteness of background, guidelines or metaknowledge knowledge may lead to insufficient knowledge about the actual situation of a patient (current state or previous states), which may result in a plan that makes a non-deterministic choice and inappropriate interventions and treatments.

5.3 Checking for inconsistencies inside the protocol

From the theoretical points of view, the proposed concept graph model have the powerful structuring mechanism, clear express meaning, well reasoning mechanism, and facilitates semantic interoperability. However, from the practical points of view, the proposed work is implemented within the Conceptual Graphs Graphical User Interface (CoGUI) (GraphIK 2012). The CoGUI is a user friendly toolbox offering a set of tools to build and query knowledge bases in conceptual graph context. Particularly, two major tools are available:

- A multilingual vocabulary management tool that is provided with vocabulary editor, Rule and Constraint editor, Pattern and Prototypic graph definitions in order to help annotation process. This tool controls the vocabulary and, if necessary, provides means to **correct it**. In the modelling phase of the guideline, the dependencies

Fig. 5 A background knowledge about a treatment of hypomagnesemia in Diabetes Mellitus

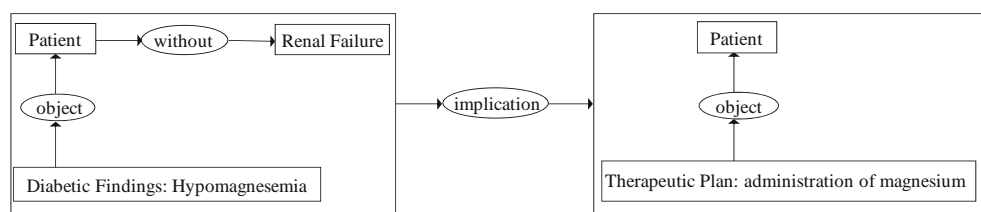
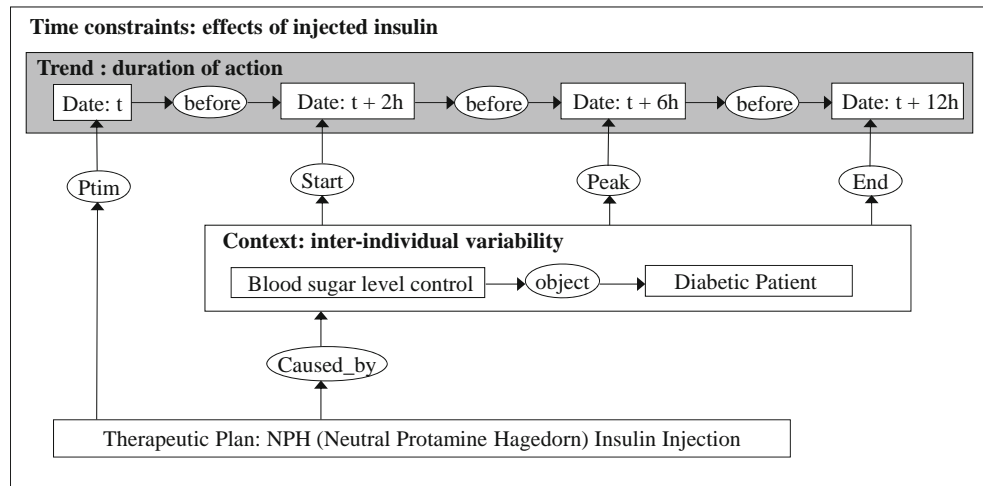

Fig. 6 A time constraint representation of guideline knowledge



between the various diagnostic and therapeutic hypotheses are represented through a graph using the concepts defined in the vocabulary description. The directionality of the inferences used in reasoning makes explicit care procedures. As a matter of fact, it is possible to visualise the reasoning process related to the diagnosis of a pathology or to the search of a prescription.

- A reasoning tool for processing and exploiting medical knowledge which allows the user to apply knowledge to deduce new facts or to check his work. The

directionality of the inferences used in reasoning makes explicit decision making procedures (Kamsu Foguem et al. 2008). As a matter of fact, it is possible to visualise the reasoning process related to the diagnosis of a pathology or to the search of a prescription. A query is processed in such network representations by projecting the corresponding CG into CGs obtained by translation of the guidelines annotations. The retrieved guidelines recommendations are those for which there exists a projection of the query graph into their annotation graph.

Fig. 7 A conceptual graph rule representation of guideline knowledge of insulin therapy

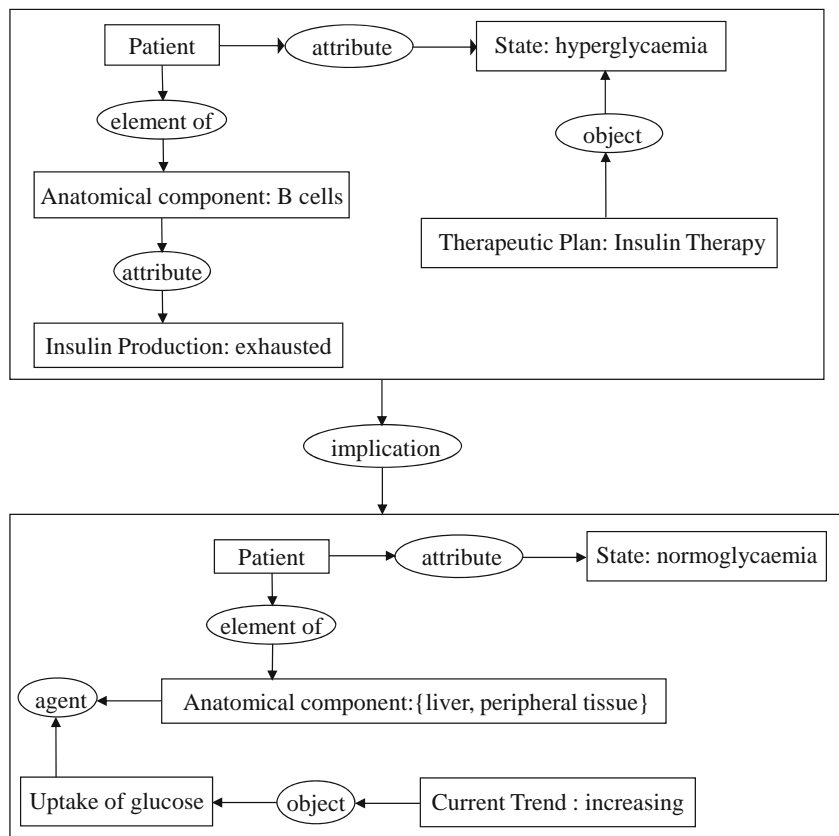

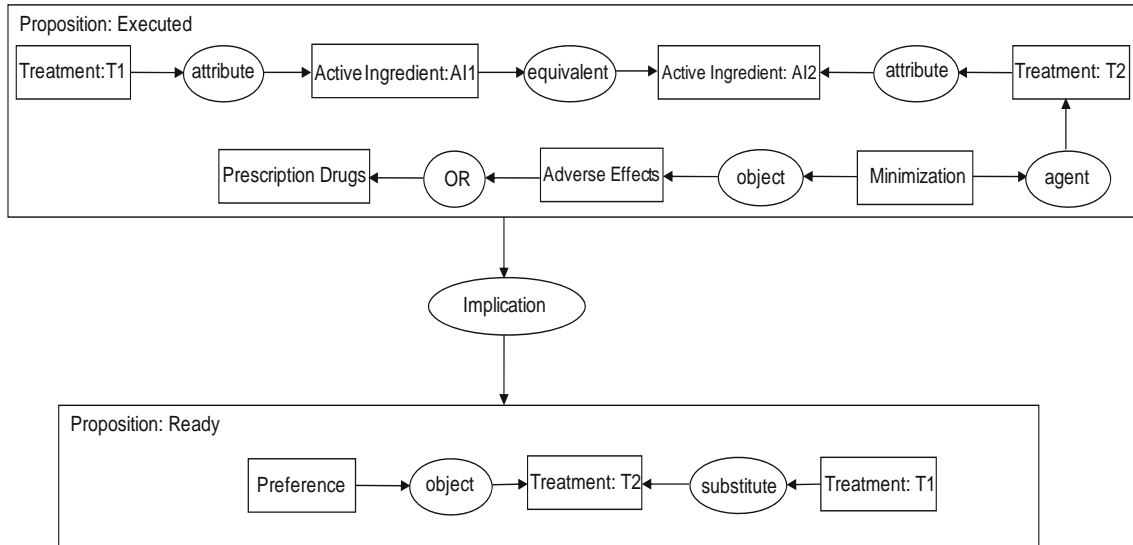

Fig. 8 A metaknowledge specification in the conceptual graph form

- In regard to patient data representation and the process of mapping guideline patient data items to real medical record models, according to the stated principle as described previously in (Achour et al. 2001), it is possible in some cases (both structured and semi-structured data) to build conceptual queries from biomedical information databases. The strong equivalence between conceptual graphs deduction and query problems in databases has often been pointed out (Mugnier and Leclère 2007). Using an original mapping between the conceptual graph and the relational database formalisms, a query graph is matched to the data graph built with data issued from each record of a medical information database by means of a pattern-matching rule (projection) that applies to conceptual graphs. For instance, the patient's glycaemic state is characterized by physiological parameters including Glucose Uptake (numeric value), from which we infer the value of the descriptor Glycaemic State (normoglycaemia, hyperglycaemia...) and the value of the trend GlucoseUptakeTrend (decreasing, increasing ...). However, the flexible projection enabled to handle the similarity that could not have been found automatically using classic SQL query since it depends on the semantic contents of textual fields and not on structured fields of the databases (some related points are considered in (Buche et al. 2006)).

The semantic verification of a guideline representation consists in checking that the guideline representation respects a set of constraints given by a medical expert. This verification is done by means of the projection operation of conceptual graphs (Fig. 9). The mechanism of semantic verification of a conceptual graph consists of checking that there exists a projection from any positive constraint and that a projection from any negative constraint does not exist in this conceptual

graph (Baget and Mugnier 2002). Thus, it becomes easy to visually show to the user where the anomalies occur with the identification of the constraints that are not satisfied in terms of conceptual graphs, very similar to the way CGPs are modelled. That, in turn, simplifies application of our approach, as the medical expert does not have to take care of the technical details of complex logic formula. Also, it is possible to study the refinement restoring the coherence and completeness of a conceptual graph knowledge base, which is not semantically valid with respect to constraints (Dibie-Barthélemy et al. 2006). Although, the proposition of a global refinement process of the knowledge base restoring mechanism is outside the scope of this paper, we can give some ideas in order to keep the knowledge base in a usable state. We likewise envisage that the restoring mechanism suggests modifications plus an indication of the new quality value (such as correctness, consistency, uniqueness, minimality, and coherence) after the change is really applied to the knowledge base.

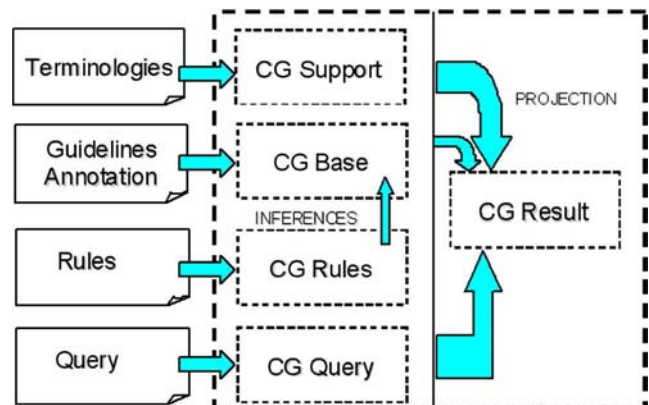

Fig. 9 Principle of conceptual graph-based checking semantic verification

6 Conclusion

In this document, we presented a formal approach for medical guidelines representation in order to improve the quality of ICU support tools. The proposed graph-based approach allows us to build formal domain vocabularies and uses visual graph transformations supporting semantic similarities reasoning. Certainly, the main contribution of the proposed approach is that it helps in clarifying medical knowledge representation, in improving the rigour of the analysis performed and in making the reasoning steps explicit. Since the underlying structure of the undertaken graph-based approach can support a broad variety of inferences that goes far beyond logical deduction (Chein and Mugnier 2008), our work can be considered as an innovative approach in the sense that it allows the clinician to follow reasoning processes in a graphical way and facilitates user's interaction. This aspect is very important because (in our opinion) this facilitates the appropriation and the control of the semantics which is associated with the CGPs representations. Thus, the resulting obtained representations will facilitate the use of medical guidelines in concert with a health information technology system (De Clercq et al. 2004; Patel et al. 2001). Certainly, different kinds of CGPs representation exist, which try to cover similar tasks, but they usually require a formal methods expert with strong background in the used language. Two others main benefits are provided by the proposed methodology:

- From a **communication viewpoint**: besides, in the existing computer-interpretable guideline methods, it is now known that there is a whole complex process involved in the transformation of a text CGPs into formal knowledge (Pérez and Porres 2010). Whereas, conceptual graphs are a formal representation language (logically founded) designed to map to and from natural languages in as simple and direct manner as possible (Sowa 2000; Zweigenbaum 1994). Meanwhile, the existence of a standard (such as Conceptual Graphs Extensible Markup Language) when the graphs themselves are exchanged, facilitates the connection of different knowledge systems that are able to encode or decode conceptual graphs. Conceptual graphs can be easily translated into the terminology of some other approaches in knowledge engineering, such as RDFS (Yao and Eitzkorn 2006) and its evolution, the OWL (Argüello Casteleiro and Des Diz 2008; Horrocks et al. 2005) mainly applied in connection with the "Semantic Web" scheme. This is a useful and practical advantage in healthcare, because it defines the ability of different information technology systems and software applications to communicate effectively and consistently, the information to be exchanged (Dieng-Kuntz et al. 2006; Corby et al. 2006).

- From a **maintenance viewpoint**: general problems associated with family of conceptual graph based reasoning are NP-hard (Chein and Mugnier 1992). However, some polynomial cases obtained by restricting the structures of the graphs are used in real-world knowledge (Baget and Mugnier 2002). Another advantage is the possibility to make appropriate trades between biological fidelity and computational expediency (Khelif et al. 2007). The main feature of the proposed approach is the ability to create and maintain links between a guideline text file and its representing conceptual graphs file. The knowledge engineer should always define links during the translation task. Since, the CoGUI architecture (GraphIK 2012) includes components such as a vocabulary management tool and a rules engine that executes declarative if-then rules; this tool enables us to create links between the original guideline and its formal representation and ease the editing of guidelines. In the maintenance context, the vocabulary tool manages changes in concept definitions over time, and rule engine also manages changes in rules that might occur due to changes in the clinical guideline specifications that occur over time.

The associated reasoning tools of our approach are mainly aimed at providing guided support to the physician during the application of the guideline. For instance, specific information useful for the background hypotheses and temporal evolution of patients may be confronted by the physician in order to make informed decisions. Such a medical decision making often involves making a diagnosis and selecting an appropriate treatment (Arocha et al. 2005), which must be performing properly (i.e. quickly and accurately) in critical situations. Further measures used for the clinical evaluation would include quantitative measures such as the number of accurate answers to some queries generated by other typical clinical protocol (e.g. cardiopulmonary, geriatric, neurological, nephrology and urologic protocols). There is also an important need to develop a deep study of efficient heuristics of the basic problems (deduction, consistency, query answering). Finally, the complexity of the decision-making process in medical domain - as well as building user friendly CGPs representations - suggests that it is necessary to better interoperate with a different set of expressive and reasoning capabilities offer by several approaches.

References

- Abu-Hanna, A., Cornet, R., De Keizer, N., Crubézy, M., & Tu, S. (2005). PROTÉGÉ as a vehicle for developing medical terminological systems. *International Journal of Human Computer Studies*, 62(5), 639–663.
- Achour, S. L., Dojat, M., Rieux, C., Bierling, P., & Lepage, E. (2001). A UMLS-based knowledge acquisition tool for rule-based clinical decision support system development. *Journal of the American Medical Informatics Association*, 8(4), 351–360.

- Argüello Casteleiro, M., & Des Diz, J. J. (2008). Clinical practice guidelines: A case study of combining OWL-S, OWL, and SWRL. *Knowledge-Based Systems*, 21(3), 247–255.
- Arocha, J. F., Wang, D., & Patel, V. L. (2005). Identifying reasoning strategies in medical decision making: A methodological guide. *Journal of Biomedical Informatics*, 38(2), 154–171.
- Baader, F., Molitor, R., & Tobies S. (1999). Tractable and Decidable Fragments of Conceptual Graphs. *Proceedings of the 7th International Conference on Conceptual Structures (ICCS'99)*, Blacksburg, VA, USA, Tepfenhart, W. & Cyre, W. (Eds.), LNAI 1640, 480–493.
- Baget, J.-F., & Mugnier, M.-L. (2002). Extensions of simple conceptual graphs: the complexity of rules and constraints. *Journal of Artificial Intelligence Research (JAIR)*, 16, 425–465.
- Balser, M., Reif, W., Schellhorn, G., Stenzel, K., & Thums, A. (2000). Formal system development with KIV. In: *Maibaum, T, editor; Fundamental approaches to software engineering*, number 1783 in LNCS. New York (USA): Springer; 2000. p. 363–6.
- Bell, D. S., Pattison-Gordon, E., & Greenes, R. A. (1994). Experiments in concept modelling for radiographic image reports. *Journal of the American Medical Informatics Association*, 1, 249–262.
- Bernauer, J., & Schoop, D. (1998). Formal classification of medical concept descriptions: graph-oriented operators. *Methods of Information in Medicine*, 37(4–5), 510–517.
- Boaz, D., & Shahar, Y. (2005). A framework for distributed mediation of temporal-abstraction queries to clinical databases. *Artificial Intelligence in Medicine*, 34(1), 3–24.
- Borgida, A. (1996). On the relative expressiveness of description logics and predicate logics. *Artificial Intelligence*, 82(1–2), 353–367.
- Boxwala, A. A., Peleg, M., Tu, S., Ogunyemi, O., Zeng, Q. T., Wang, D., et al. (2004). GLIF3: a representation format for sharable computer-interpretable clinical practice guidelines. *Journal of Biomedical Informatics*, 37(3), 147–161.
- Buche, P., Dibie-Barthélemy, J., Hammerlé, O., & Thomopoulos, R. (2006). Fuzzy concepts applied to the design of a database in predictive microbiology. *Fuzzy Sets and Systems*, 157(9), 1188–1200.
- Campbell, K. E., Das, A. K., & Musen, M. A. (1994). A logical foundation for representation of clinical data. *Journal of the American Medical Informatics Association*, 1(3), 218–232.
- Campbell, K. E., Oliver, D. E., & Shortliffe, E. H. (1998). The Unified Medical Language System: toward a collaborative approach for solving terminologic problems. *Journal of the American Medical Informatics Association*, 5(1), 12–16.
- Carloni, O., Leclère, M., & Mugnier, M.-L. (2009). Introducing reasoning into an industrial knowledge management tool. *Applied Intelligence*, 31(3), 211–224.
- Chein, M., & Mugnier, M.-L. (1992). Conceptual graphs: fundamental notions. *Artificial Intelligence Review*, 6(4), 365–406.
- Chein, M. & Mugnier, M.-L. (2008). *Graph-based Knowledge Representation: Computational Foundations of Conceptual Graphs*. Series: Advanced Information and Knowledge Processing. Publisher: Springer, 445 pages, Hardcover, ISBN 978-1-84800-285-2. London (United Kingdom).
- Chu, S., & Cesnik, B. (2001). Knowledge representation and retrieval using conceptual graphs and free text document self-organisation techniques. *International Journal of Medical Informatics*, 62(2–3), 121–133.
- Corby, O., Dieng-Kuntz, R., Faron-Zucker, C., & Gandon, F. (2006). Searching the semantic web: approximate query processing based on ontologies. *IEEE Intelligent Systems Journal*, 21(1), 20–27.
- Dau, F., & Eklund, P. (2008). A diagrammatic reasoning system for the description logic. *Journal of Visual Languages and Computing*, 19(5), 539–573.
- De Clercq, P. A., Blom, J. A., Korsten, H. H. M., & Hasman, A. (2004). Approaches for creating computer-interpretable guidelines that facilitate decision support. *Artificial Intelligence in Medicine*, 31(1), 1–27.
- Delamarre, D., Burgun, A., Seka, L. P., & Le Beux, P. (1995). Automated coding of patient discharge summaries using conceptual graphs. *Methods of Information in Medicine*, 34(4), 345–351.
- Delugach, H.S., & Rochowiak, D. (2008). Grounded Conceptual Graph Models. *Proceedings of the 16th International Conference on Conceptual Structures (ICCS 2008)*, Eklund P. & Haemmerlé O. (Eds.), Conceptual Structures: Knowledge Visualization and Reasoning, Toulouse (France), LNAI 5113, pp. 269–281.
- Dibie-Barthélemy, J., Haemmerlé, O., & Salvat, E. (2006). A semantic validation of conceptual graphs. *Knowledge-Based Systems*, 19(7), 498–510.
- Dieng-Kuntz, R., & Corby, O. (2005). Conceptual Graphs for Semantic Web Applications. *Proceedings of the 13th Int. Conference on Conceptual Structures (ICCS'2005)*, Dau, F., Mugnier, M.-L., Stumme, G. (editors), Kassel (Germany), July 17–23, 2005, Springer-Verlag, LNAI 3596, ISBN 978-3-540-27783-5, p. 19–50.
- Dieng-Kuntz, R., Minier, D., Ruzicka, M., Corby, F., Corby, O., & Alamarguy, L. (2006). Building and using a medical ontology for knowledge management and cooperative work in a health care Network. *Computers in Biology and Medicine*, 36(7–8), 871–892.
- Dojat, M., Ramaux, N., & Fontaine, D. (1998). Scenario recognition for temporal reasoning in medical domains. *Artificial Intelligence in Medicine*, 14(1–2), 139–155.
- Dojat, M., Pachet, F., Guessoum, Z., Touchard, D., Harf, A., & Brochard, L. (1997). NeoGanesh: A working system for the automated control of assisted ventilation in ICUs. *Artificial Intelligence in Medicine*, 11(2), 97–117.
- Duftschnid, G., Miksch, S., & Gall, W. (2002). Verification of temporal scheduling constraints in clinical practice guidelines. *Artificial Intelligence in Medicine*, 25(2), 93–121.
- Fürst, F., Leclère, M., & Trichet, F. (2003). Ontological engineering and mathematical knowledge management: A formalization of projective geometry. *Annals of Mathematics and Artificial Intelligence*, 38(1), 65–89.
- Gardner, M.-R. (2004). Computerized clinical decision-support in respiratory care. *Respiratory Care Journal*, 49(4), 378–386.
- Genest, D., & Chein, M. (2005). A content-search information retrieval process based on conceptual graphs. *Knowledge And Information Systems*, 8(3), 292–309.
- GraphIK Team (2012). CoGUI (Conceptual Graphs Graphical User Interface), User guide, document available at the following web site: <http://www2.lirmm.fr/cogui/index.php>. Last accessed May 28, 2012.
- Henry, S. B., & Mead, C. N. (1997). Nursing classification systems: necessary but not sufficient for representing “what nurses do” for inclusion in computer-based patient record systems. *Journal of the American Medical Informatics Association*, 4(3), 222–232.
- Hommersom, A., Groot, P., Lucas, P. J. F., Balser, M., & Schmitt, J. (2007). Verification of medical guidelines using background knowledge in task networks. *IEEE Transactions on Knowledge and Data Engineering*, 19(6), 832–846.
- Horrocks, I., Patel-Schneider, P. F., Bechhofer, S., & Tsarkov, D. (2005). OWL rules: A proposal and prototype implementation. *Web Semantics: Science, Services and Agents on the World Wide Web*, 3(1), 23–40.
- Hripsak, G., Ludemann, P., Pryor, T. A., Wigertz, O. B., & Clayton, P. D. (1994). Rationale for the Arden Syntax. *Computers and Biomedical Research*, 27(4), 291–324.
- Kamsu Foguem, B., Coudert, T., Geneste, L., & Beler, C. (2008). Knowledge formalization in experience feedback processes: an ontology-based approach. *Computers in Industry*, 59(7), 694–710.
- Kamsu-Foguem, B., & Chapurlat, V. (2006). Requirements modelling and formal analysis using graph operations. *International Journal of Production Research*, 44(17), 3451–3470.

- Khelif, K., Dieng-Kuntz, R., & Barbry, P. (2007). An ontology-based approach to support text mining and information retrieval in the biological domain. *Journal of Universal Computer Science*, 13(12), 1881–1907.
- Kitabchi, A. E., & Nyenwe, E. A. (2006). Hyperglycemic crises in diabetes mellitus: diabetic ketoacidosis and hyperglycemic hyperosmolar state. *Endocrinology And Metabolism Clinics Of North America*, 35(4), 725–751.
- Latoszek-Berendsen, A., Tange, H., van den Herik, H.J., & Hasman, A. (2010). From Clinical Practice Guidelines to Computer-interpretable Guidelines. A Literature Overview. *Methods of Information in Medicine*, 18;49(6):550-570.
- MacIsaac, R. J., Lee, L. Y., McNeil, K. J., Tsalamandris, C., & Jerums, G. (2002). Influence of age on the presentation and outcome of acidotic and hyperosmolar diabetic emergencies. *Internal Medicine Journal*, 32(8), 379–385.
- Magee, M. F., & Bhatt, B. A. (2001). Management of decompensated diabetes. Diabetic ketoacidosis and hyperglycemic hyperosmolar syndrome. *Critical Care Clinics*, 17(1), 75–106.
- Manjarrés Riesco, A., Martínez Tomás, R., & Mira Mira, J. (2000). A customisable framework for the assessment of therapies in the solution of therapy decision tasks. *Artificial Intelligence in Medicine*, 18(1), 57–82.
- Marino, P.L., & Sutin, K.M. The ICU Book. ISBN-10: 078174802X, ISBN-13: 978-0781748025. Publisher: Lippincott Williams and Wilkins; 3rd Revised edition edition (1 Oct 2006), Philadelphia, Pennsylvania, U.S.A. Paperback: 1065 pages.
- Moulin, B. (1997). Temporal Contexts for Discourse Representation: An Extension of the Conceptual Graph Approach. *Applied Intelligence*, 7(3), 227–255.
- Mugnier, M. L. (1995). On generalization/specialization for conceptual graphs. *Journal of Experimental and Theoretical Artificial Intelligence*, 7(3), 325–344.
- Mugnier, M.-L., & Leclère, M. (2007). On querying simple conceptual graphs with negation. *Data & Knowledge Engineering*, 60(3), 468–493.
- Müller, R. (1997). The CliniCon Framework for Context Representation in Electronic Patient Records. In: Daniel R. Masys (ed.): *Proceedings of the 1997 Fall Symposium of the American Medical Informatics Association (formerly SCAMC)*, Nashville, TN, USA. Hanley & Belfus, pp. 178-182.
- Musen, M., Tu, S., Das, A., & Shahar, Y. (1996). EON: A component-based approach to automation of protocol-directed therapy. *Journal of the American Medical Informatics Association*, 3(6), 367–388.
- Naudet, Y., Latour, T., Guedria, W., & Chen, D. (2010). Towards a systemic formalisation of interoperability. *Computers in Industry*, 61(2), 176–185.
- Park, S., & Kyu Lee, J. (2007). Rule identification using ontology while acquiring rules from Web pages. *International Journal of Human Computer Studies*, 65(7), 659–673.
- Patel, V. L., Arocha, J. F., & Kaufman, D. R. (1994). Diagnostic reasoning and medical expertise. In D. Medin (Ed.), *The psychology of learning and motivation*, 31 (pp. 187–252). San Diego: Academic Press.
- Patel, V. L., Arocha, J. F., Diermeier, M., How, J., & Mottur-Pilson, C. (2001). Cognitive psychological studies of representation and use of clinical practice guidelines. *International Journal of Medical Informatics*, 63(3), 147–167.
- Peleg, M., Tu, S., Bury, J., Ciccicarese, P., Fox, J., Greenes, R. A., et al. (2003). Comparing computer-interpretable guideline models: a case-study approach. *Journal of the American Medical Informatics Association*, 10(1), 52–68.
- Pérez, B., & Porres, I. (2010). Authoring and verification of clinical guidelines: A model driven approach. *Journal of Biomedical Informatics*, 43(4), 520–536.
- Purves, N. (1998). PRODIGY: implementing clinical guidance using computers. *British Journal of General Practice*, 48(434), 1552–1553.
- Quaglini, S., Stefanelli, M., Cavallini, A., Micieli, G., Fassino, C., & Mossa, C. (2000). Guideline-based careflow systems. *Artificial Intelligence in Medicine*, 20(1), 5–22.
- Shahar, Y. (1997). A framework for knowledge-based temporal abstraction. *Artificial Intelligence*, 90(1–2), 79–133.
- Shahar, Y. (2000). Dimension of time in illness: an objective view. *Annals of Internal Medicine*, 132(1), 45–53.
- Shahar, Y., & Musen, M. A. (1996). Knowledge-based temporal abstraction in clinical domains. *Artificial Intelligence in Medicine*, 8(3), 267–298.
- Shahar, Y., Miksch, S., & Johnson, P. (1998). The asgaard project: a task-specific framework for the application and critiquing of time-oriented clinical guidelines. *Artificial Intelligence in Medicine*, 14(1–2), 29–51.
- Shahar, Y., Young, O., Shalom, E., Galperin, M., Mayaffit, A., Moskovitch, R., et al. (2004). A framework for a distributed, hybrid, multiple-ontology clinical-guideline library, and automated guideline-support tools. *Journal of Biomedical Informatics*, 37(5), 325–344.
- Slaughter, L. A., Soergel, D., & Rindfleisch, T. C. (2006). Semantic representation of consumer questions and physician answers. *International Journal of Medical Informatics*, 75(7), 513–529.
- Solnon, C. (2010). AllDifferent-based filtering for subgraph isomorphism. *Artificial Intelligence*, 174(12–13), 850–864.
- Sowa, J. F. (1984). *Conceptual structures: information processing in mind and machine. The Systems Programming Series (Hardcover)* (p. 481). Boston: Addison-Wesley Longman Publishing Co., Inc.
- Sowa, J. F. (2000). *Knowledge Representation: Logical, Philosophical, and Computational Foundations* (p. 608). Pacific Grove: Brooks Cole Publishing Co. ISBN 0-534-94965-7.
- Sowa, J. F., & Zachman, J. A. (1992). Extending and formalizing the framework for information systems architecture. *IBM Systems Journal*, 31(3), 590–616.
- Steimann, F., & Adlassnig, K.-P. (1998). Fuzzy Medical Diagnosis. In E. Ruspini, P. Bonissone, & W. Pedrycz (Eds.), *Handbook of Fuzzy Computation* (pp. G13.1:1–G13.1:14). Bristol: IOP Publishing Ltd and Oxford University Press.
- Stoner, G. D. (2005). Hyperosmolar hyperglycemic state. *American Family Physician*, 71(9), 1723–1730.
- Sutton, D. R., Taylor, P., & Earle, K. (2006). Evaluation of PROforma as a language for implementing medical guidelines in a practical context. *BMC Medical Informatics and Decision Making*, 6, 20.
- Takroui, M. S. M. (2004). Intensive Care Unit. *The Internet Journal of Health*, 3(2). doi:10.5580/1c97.
- Ten Teije, A., Marcos, M., Balsler, M., Van Croonenborg, J., Duelli, C., Van Harmelen, F., et al. (2006). Improving medical protocols by formal methods. *Artificial Intelligence in Medicine*, 36(3), 193–209.
- Terenziani, P., Montani, S., Bottrighi, A., Torchio, M., Molino, G., & Correndo, G. (2004). The GLARE approach to clinical guidelines: main features. *Studies In Health Technology And Informatics*, 101(3), 162–166.
- Thomopoulos, R., Buche, P., & Hammerlé, O. (2003). Representation of weakly structured imprecise data for fuzzy querying. *Fuzzy Sets and Systems*, 140(1), 111–128.
- Tu, S. W., Campbell, J. R., Glasgow, J., Nyman, M. A., McClure, R., McClay, J., et al. (2007). The SAGE guideline model: achievements and overview. *Journal of the American Medical Informatics Association*, 14(5), 589–598.
- Volot, F., Joubert, M., & Fieschi, M. (1998). Review of biomedical knowledge and data representation with conceptual graphs. *Methods of Information in Medicine*, 37(1), 86–96.
- Wang, D., Peleg, M., Tu, S. W., Boxwala, A. A., Greenes, R. A., Patel, V. L., et al. (2002). Representation primitives, process models and patient data in computer-interpretable clinical practice guidelines: A literature review of guideline representation models. *International Journal of Medical Informatics*, 68(1–3), 59–70.

- Ward, N. S. (2004). Using computers for intensive care unit research. *Respiratory Care Journal*, 49(5), 518–522.
- Yao, H., & Eitzkorn, L. (2006). Automated conversion between different knowledge representation formats. *Knowledge-Based Systems*, 19(6), 404–412.
- Zweigenbaum, P. (1994). MENELAS: an access system for medical records using natural language. *Computer Methods and Programs in Biomedicine*, 45(1–2), 117–120.

Bernard Kamsu-Foguem is an Assistant Professor at the National Engineering School of Tarbes (ENIT) of National Polytechnic Institute of Toulouse (INPT) and leads his research activities in the Production Engineering Laboratory (LGP) of ENIT-INPT, a research entity (EA 1905) of the University of Toulouse. He has a Master's in Operational Research, Combinatorics and Optimisation (2000) from National Polytechnic Institute of Grenoble, and a PhD in Computer Science and Automatic (2004) from the University of Montpellier 2. His current interests are in Knowledge Representation, Visual Reasoning, Ontology-based Semantic Analysis and Knowledge Exploitation for Collaboration and Decision Support. Application domains include continuous improvement process, industrial maintenance management, conventional and traditional medicine. He has authored or co-authored a number of papers in the international scientific journals such as *Decision Support Systems*, *Engineering Applications of Artificial Intelligence*, *Computers in Industry*, *Advanced Engineering Informatics*, *Annual Reviews in Control and International Journal of Production Research*. He is a reviewer for a large number of international scientific journals such as *Concurrent Engineering: Research and Applications*, *Engineering Applications of Artificial Intelligence*, *International Journal of Computer Engineering Research*, *Knowledge Management Research & Practice*, *Journal of Intelligent Manufacturing*, and *Knowledge-Based Systems*. Dr. B. Kamsu-Foguem was recently awarded two prizes (Best Paper Award in 2009 and 2011 from the SKIMA - IEEE conferences) and one audience distinction (Most Downloaded Engineering Applications of Artificial Intelligence Article from SciVerse ScienceDirect in 2012) for his research topics in continuous improvement, knowledge reasoning and maintenance management. He is interested in the international network and collaboration with other institutions and researchers related to research projects, course development and delivery.

Germaine Tchuenté-Foguem is PhD student at the Lille2 University. She has a Master of Advanced Studies from the University of Yaounde I (Cameroon) in 2007, in the domain of synchronization in dynamic distributed systems, and a Research Master in automatic and decisional systems obtained in 2010 from ENIT-INPT of Tarbes (France). She is the co-author of a journal article published in *Decision Support Systems* and focused on a knowledge-based information system for visual support in critical decision-making an effective framework for improving the diagnosis or treatment of Traumatic Brain Injury patients. She currently takes an active interest in complex signals analysis with the specific aim of improving the patient monitoring in intensive care units, through false alarm reduction strategies, to help clinicians to predict status changes for better patient care. She has also interest in Intelligent User Interface Design to develop Medical Device User Interfaces that are user-centred, maximise perceptual reasoning and minimise user errors for intuitive manipulations.

Clovis Foguem is an Internal Medicine and Geriatric Medicine doctor (MD), former Junior Lecturer of physiology and medical pathology at the Medical and Social National Institute [Cotonou, Benin] and former Clinical instructor and Hospital consultant, in Geriatrics at the Faculty of Medicine and at the CHU (Teaching Hospital) of Besancon [France]. He is now Hospital practitioner at Acute Geriatric Unit of Auban-Moët Hospital Center [Epernay, France]. He has a Master in Sciences, technologies, health with purpose research. Mention biology, health, speciality physiology, neurosciences and Behaviour from Franche-Comté's University: Faculty of Sciences [Besancon, France] and undertakes a PhD on: 'Olfaction and Elderly: study of the olfactive and trigeminal interactions in a geriatric population; constants and pathological specificities' at Center for Food and Taste sciences (CSGA) - UMR 6265 CNRS – UMR 1324 INRA - University of Burgundy [France]. For the work above, on olfaction, Dr C. Foguem was laureate of the Health Research Advancement Award of the Corporate foundation 'Groupe Pasteur Mutualité' (a French mutual's group of leading insurance administered by healthcare professionals) in 2011. He is also particularly interested in elderly epilepsy, neurodegenerative diseases (as Parkinson disease or Lewy Body dementia ...) and whether pathogenic inflammatory responses can contribute to these disorders in the elderly. Moreover he is also interested in medical knowledge representation and medical clinic design guidelines. He has authored or co-authored twenty-two articles in scientific journals and international conferences. He is peer-reviewer of the Medical press journals: *Clinical Interventions in Aging*; *Degenerative Neurological and Neuromuscular Disease*; *International Medical Case Reports Journal*; *Neuroscience and Neuroeconomics*; *Clinical Medicine Insights*.