



**HAL**  
open science

# Physical mapping of stable RNA genes in *Bacillus subtilis* using polymerase chain reaction amplification from a yeast artificial chromosome library

Kathleen Okamoto, Pascale Serror, Vasco Azevedo, Barbara Vold

## ► To cite this version:

Kathleen Okamoto, Pascale Serror, Vasco Azevedo, Barbara Vold. Physical mapping of stable RNA genes in *Bacillus subtilis* using polymerase chain reaction amplification from a yeast artificial chromosome library. *Journal of Bacteriology*, 1993, 175 (14), pp.4290-42977. hal-02702481

**HAL Id: hal-02702481**

**<https://hal.inrae.fr/hal-02702481>**

Submitted on 1 Jun 2020

**HAL** is a multi-disciplinary open access archive for the deposit and dissemination of scientific research documents, whether they are published or not. The documents may come from teaching and research institutions in France or abroad, or from public or private research centers.

L'archive ouverte pluridisciplinaire **HAL**, est destinée au dépôt et à la diffusion de documents scientifiques de niveau recherche, publiés ou non, émanant des établissements d'enseignement et de recherche français ou étrangers, des laboratoires publics ou privés.

## Physical Mapping of Stable RNA Genes in *Bacillus subtilis* Using Polymerase Chain Reaction Amplification from a Yeast Artificial Chromosome Library

KATHLEEN OKAMOTO,<sup>1</sup> PASCALE SERROR,<sup>2</sup> VASCO AZEVEDO,<sup>2</sup> AND BARBARA VOLD<sup>1\*</sup>  
*SYVA Company, 900 Arastradero Road, M/S 2-218, Palo Alto, California 94304,<sup>1</sup> and Laboratoire de Genetique Microbienne, Institut National de la Recherche Agronomique, Domaine de Vilvert, 78352 Jouy en Josas, France<sup>2</sup>*

Received 18 February 1993/Accepted 7 May 1993

A new approach for mapping genes which utilizes yeast artificial chromosome clones carrying parts of the *Bacillus subtilis* genome and the polymerase chain reaction technique is described. This approach was used to physically map stable RNA genes of *B. subtilis*. Results from over 400 polymerase chain reactions carried out with the yeast artificial chromosome clone library, using primers specific for the genes of interest and designed from published sequences, were collected. The locations of 10 known rRNA gene regions (*rrnO*, *rrnA*, *rrnE*, *rrnD*, *rrnB*, *rrnJ-rrnW*, and *rrnI-rrnH-rrnG*) have been determined by this method, and these results correlate with those observed by standard genetic mapping. All rRNA operons, except *rrnB*, are found between 0 and 90°, while *rrnB* has been placed in the area of 270° on the chromosome map. Also localized were the tRNA gene clusters associated with the following ribosomal operons: *rrnB* (21 tRNAs), *rrnJ* (9 tRNAs), *rrnD* (16 tRNAs), and *rrnO* and *rrnA* (2 internal tRNAs). A previously unmapped four-tRNA gene cluster, *trnY*, a tRNA gene region that is not associated with a ribosomal operon, was found near the origin of replication. The P-RNA gene, important for processing of tRNAs, was found between map locations 197 and 204°.

*Escherichia coli*, the traditional representative gram-negative organism, and *Bacillus subtilis*, a recognized representative gram-positive organism, have both been well studied, and many of their genes have been mapped and characterized. For instance, the general organization of the rRNA and tRNA gene regions in *B. subtilis* and the way this contrasts to that of the genes of *E. coli* have been presented in review articles (4, 16, 43). Differences in the organization of the genes for stable RNA synthesis in *B. subtilis* and *E. coli* could be indicative of differences between gram-positive and gram-negative organisms (16). One major difference is that the tRNAs of *B. subtilis* are highly clustered and are usually distal to a ribosomal operon, whereas those of *E. coli* are scattered and are often independent transcriptional units (4, 43). All of the rRNA and tRNA genes in *E. coli* have been mapped, but until recently, not all those genes in *B. subtilis* had been similarly mapped; the 16-tRNA (reference 36 and this study) and the 4-tRNA gene clusters have escaped localization, along with the P-RNA gene, which is important for processing tRNAs (this study).

New approaches are needed to locate and confirm genes that are difficult to map by genetic and physical methods such as PBS1 transduction (21, 47), DNA-mediated transformations (11, 18), *Sfi*I and *Not*I restriction mapping (1, 25), and electron microscopic techniques (8). As illustrated here, the advent of polymerase chain reaction (PCR) and the development of the *B. subtilis* yeast artificial chromosome (YAC) library enable problem genes with known sequences to be quickly and easily mapped. Previous libraries of *B. subtilis* genes, established with  $\lambda$  and *B. subtilis* vectors, typically consisted of thousands of clones (10, 23). The YAC system allows the cloning of large fragments of DNA (7), and the *B. subtilis* YAC library contains inserts ranging in size

from 40 to 240 kb. The 59 clones which make up this library span about 98% of the *B. subtilis* genome (2). Genetic markers were used to place some of the *B. subtilis* fragments contained in the YAC clones, so PCR amplification of genes with known sequences from this YAC library is a reliable method, based on a combination of physical and genetic mapping.

### MATERIALS AND METHODS

**YAC library and construction.** A YAC library of *B. subtilis* DNA has been constructed and partially characterized previously (2). *B. subtilis* 168 DNA was partially digested with *Eco*RI and ligated with the pYAC4 vector (7), and then it was transformed into *Saccharomyces cerevisiae* SX4-6A (2). Clones were selected and ordered initially by hybridization to genes positioned on the genetic map (2). The left and right ends of the clones were recovered by cloning and PCR, respectively. These ends were then used as probes to reveal overlapping and neighboring clones, by chromosome walking. The regions of the YAC library that are pertinent to this study are shown in Fig. 1.

**PCR and primers.** The sequences of the primers used for PCR are shown in Table 1, along with the references used in primer design. For a description of primer designations, see Results. Primers were graciously made by Christopher J. Green on an ABI 380B DNA synthesizer. The amount of YAC clone DNA used in the PCRs was 10 ng. The negative controls that were run with every set of PCRs were primers alone without template DNA, and a separate reaction was run with yeast genomic DNA (10 ng) used as a template. Because the bacillus genome is about one-third the size of the yeast genome (38), 3 ng of bacillus genomic DNA was used as a positive control.

PCRs were run on a Perkin-Elmer DNA thermal cycler. The reaction components were used as previously described

\* Corresponding author.

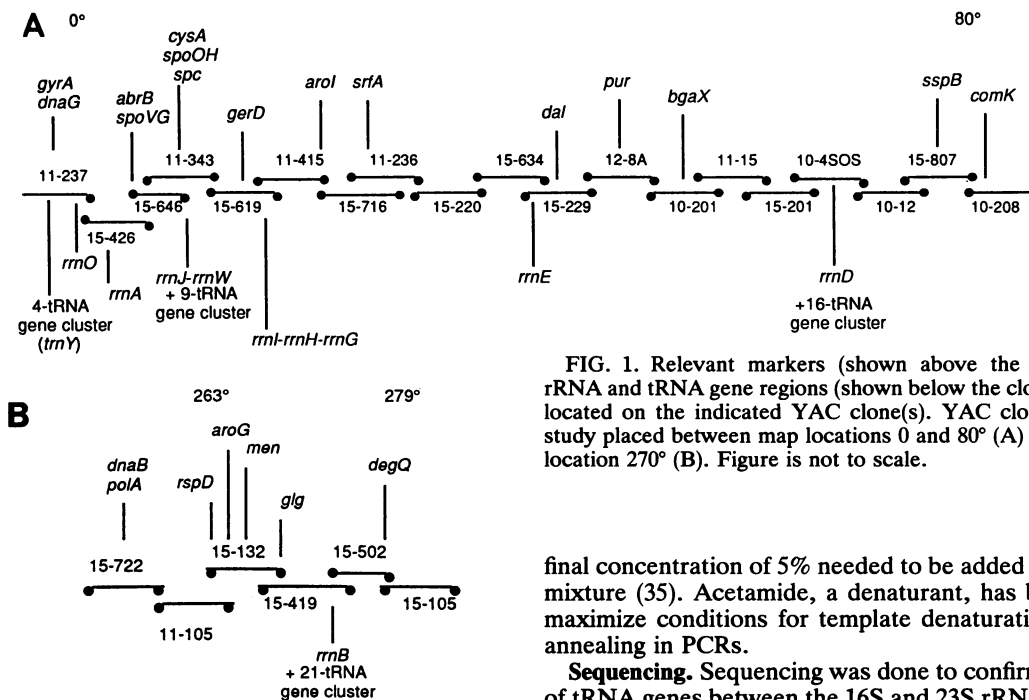

FIG. 1. Relevant markers (shown above the clones) (2) and rRNA and tRNA gene regions (shown below the clones) (this study) located on the indicated YAC clone(s). YAC clones used in this study placed between map locations 0 and 80° (A) and around map location 270° (B). Figure is not to scale.

(15). For all reactions, 30 cycles of a modified step-cycle file with a hot start were used. The tubes were incubated at 80°C for 1 to 2 min prior to and during the addition of the last reaction mixture components (the deoxynucleoside triphosphates). All reaction mixtures were heated at 94°C for 5 min prior to the start of the step-cycle file. The denaturation step was 30 s at 94°C. The annealing step was also 30 s for all reactions. The annealing temperature was determined for each primer set on the basis of the melting temperatures ( $T_m$ s) of the primers. The extension temperature for all reactions was 72°C. The length of the reaction was determined by the length of the longest band expected to be amplified from *B. subtilis* genomic DNA. To observe amplification from the primer set *gyrAD*-16SU, acetamide at a

final concentration of 5% needed to be added to the reaction mixture (35). Acetamide, a denaturant, has been shown to maximize conditions for template denaturation and primer annealing in PCRs.

**Sequencing.** Sequencing was done to confirm the presence of tRNA genes between the 16S and 23S rRNAs in *rmO* and *rmA* in the clones 11-237 and 15-426. Amplicons (PCR-amplified products) of the two clones, made with the primer set 16SD-23SU (see Table 2; see Results for a description), were purified on a 1% SeaPlaque agarose gel (FMC Corporation, Rockland, Maine) and then sequenced with the Sequenase kit for double-stranded sequencing (version 2.0; U.S. Biochemical Corporation, Cleveland, Ohio). [<sup>35</sup>S]dATP label was used for 11-237, and [<sup>32</sup>P]dCTP label was used for 15-426. A modified alkaline denaturation protocol was used (22). Each amplicon was sequenced from the 3' and 5' ends with the 16SD and the 23SU primers, respectively.

**Southern analysis.** YAC clone DNA (3 μg) was completely digested with *Bcl*I (New England Biolabs, Beverly, Mass.) to confirm the presence of a ribosomal operon on each of the clones described in Results, or it was digested with *Hind*III and/or *Eco*RI and *Bcl*I and/or *Hind*III (New England Bio-

TABLE 1. PCR primers and their sequences

Primer <sup>a</sup>	Sequence <sup>b</sup>	Reference(s)
16SD	5' CTC GAA TTC TGC GG(C/T) TGG ATC ACC TCC TT 3'	24
23SU	5' CTC TGT CGA CTG CCA (A/G)GG CAT CCA CCG TG 3'	17
5SD	5' CTC GAA TTC ACA CCC GTT CCG AT(A/G/C) CCG AA 3'	9
16SU	5' CTC TGT CGA CTG AGC CA(G/T) GAT CAA ACT C 3'	24
23SD	5' CTC GAA TTC TAA TCG ATC GAG G(A/G)C TTA ACC 3'	17
AlaU	5' CTC GTC GAC CCC AGC TGA GCT AAG GCC CC 3'	33
<i>rmAU</i>	5' CTC GTC GAC GCC TTC AGG ATG AAG GTA CT 3'	33
<i>gyrAD</i>	5' CTC GAA TTC GTC ACT CAA GGT GTG CGT CTC 3'	31
PheU	5' CTC TGT CGA CAC (A/G)GA AT(C/T) GAA G(C/G/T)G CCG ACA C 3'	40, 48
GluU	5' CTC TGT CGA CG(C/T) GTA CCG G(A/G)T TCG AAC C 3'	40, 48
LeuU	5' CTC TGT CGA CG(G/C) A(A/G)G GCC GGA CTT GAA CC 3'	14, 40
ArgD	5' CTC GAA TTC TTG GAT AGA (G/T)CG (C/T)TT GAC TAG G 3'	14, 40
LysD	5' CTC GAA TTC AG(C/T) (G/T)GG TAG AGC A(A/T)C TG(G/A) CTT TT 3'	40, 48
ThrD	5' CTC GAA TTC TCA (A/G)TT GGT AGA G(C/T)A ACT GAG T 3'	14, 40
P-RNAD	5' CTC GAA TTC GTT CTT AAC GTT CCG GTA ATC G 3'	6, 34
P-RNAU	5' CTC GTC GAC AAG TGG TCT AAC GTT CTG TAA G 3'	6, 34

<sup>a</sup> For explanations of designations, see Results.

<sup>b</sup> Underlined sequences are specific for the gene of interest. Primers with variable bases were designed by Christopher J. Green for evolutionary studies of rRNA and tRNA gene regions of other gram-positive organisms.

TABLE 2. Primer sets, their target region(s), and interpretation of expected amplicon(s)<sup>a</sup> from *B. subtilis* genomic DNA

Target region	Primer set	Length of bands expected (bp)	Interpretation of amplified bands
Within an rRNA operon	16SD-23SU	250	No internal tRNA genes
		450	Internal tRNA genes
Associated or internal regions of <i>rmA</i> and/or <i>rmO</i>	16SD-AlaU	250	<i>rmO</i> and/or <i>rmA</i>
	23SD- <i>rmA</i> U	160	<i>rmA</i>
	<i>gyrA</i> D-16SU	490	<i>rmO</i>
Between rRNA operons	5SD-16SU	300; 900	Cluster <i>rmI-rmH-rmG</i>
	23SD-16SU	1,150	Cluster <i>rmJ-rmW</i>
		400; 1,000	Cluster <i>rmI-rmH-rmG</i>
		1,200	Cluster <i>rmJ-rmW</i>
Within a tRNA gene cluster			
16-tRNA gene cluster	5SD-GluU	370	16-tRNA gene cluster
21-tRNA gene cluster	ArgD-PheU	760	21-tRNA gene cluster
16- and 21-tRNA gene clusters	5SD-PheU	700	16-tRNA gene cluster
	23SD-LeuU	1,470	21-tRNA gene cluster
		1,550	16-tRNA gene cluster
		700	21-tRNA gene cluster
16-, 21-, and 9-tRNA gene clusters	5SD-LeuU	1,450	16-tRNA gene cluster
	ThrD-LeuU	670	21-tRNA gene cluster
		600	9-tRNA gene cluster
		730	16-tRNA gene cluster
		430	21-tRNA gene cluster
		490	9-tRNA gene cluster
21- and 4-tRNA gene clusters	LysD-PheU	1,140	21-tRNA gene cluster
		410	4-tRNA gene cluster

<sup>a</sup> An amplicon is a PCR-amplified product.

labs) to verify the overlap of a ribosomal operon on clones 15-419 and 15-502. After agarose gel electrophoresis in Tris-borate-EDTA buffer, the DNAs were transferred to nitrocellulose (Hybond C; Amersham, Arlington Heights, Ill.) (37). After hybridization (39), the membranes were first washed in 2× SSC (1× SSC is 0.15 M NaCl plus 0.015 M sodium citrate) (37)–0.5% sodium dodecyl sulfate (SDS) for 15 min at 42°C, and then they were washed for 15 min twice in 1× SSC–0.1% SDS, first at 50°C and then at 60°C. The probes were PCR fragments containing the 23S- and 16S-rRNA genes. The primers used to generate the 23S probe were complementary to and primed in an upstream direction from the 3′ end of the 23S-rRNA gene (5′ CTC GTC GAC TGG TTA AGT CCT CGA TCG ATT AG 3′;  $T_m = 66^\circ\text{C}$ ) (13, 17) and the 3′ end of the 16S-rRNA gene, designated 16SD. The sequence of primer 16SD is given in Table 1; see Results for a description of primer designations used in this study. The two primers used to generate the 16S probe were complementary to and primed in an upstream direction from the 3′ end of the 16S-rRNA gene (5′ CTC GTC GAC GGA GGT GAT CCA (G/T)CC GCA C 3′;  $T_m = 62^\circ\text{C}$ ) and complementary to and primed in a downstream direction from the 5′ end of the 16S-rRNA gene (5′ CTC GAA TTC TCG GAG AGT TTG ATC CTG GCT 3′;  $T_m = 64^\circ\text{C}$ ) (13, 24). The probes were labelled with [<sup>32</sup>P]dCTP by using a random priming labelling kit (Boehringer Mannheim, Indianapolis, Ind.) according to the manufacturer's instructions.

## RESULTS

**General PCR strategy.** A simple PCR strategy which used primers specific for *B. subtilis* genes of interest was designed. In some cases, more than one region would be amplified, and the primers were designed so that these regions could be clearly differentiated by amplicon length. Table 2 shows the primer sets which were used for each distinct gene region, the lengths of the bands expected to be amplified, and the interpretation of the presence of the amplified bands. The table is organized by the following target regions: the region within an rRNA operon, internal regions of *rmO* and/or *rmA* and associated regions, the region between rRNA operons, and the region within a tRNA gene cluster. The primers are abbreviated as follows: 16S, 23S, and 5S refer to rRNA genes; *rmA* refers to the *rmA* operon; *gyrA* refers to a genetic marker upstream of *rmO*; and Ala, Phe, Leu, Glu, Thr, Lys, and Arg each refer to a specific tRNA gene which recognizes that particular amino acid. D and U refer to the direction in which the primer faces: e.g., 16SD refers to the primer with homology to the 3′ end of the 16S-rRNA gene and which primes in a downstream direction, and 23SU refers to the primer with homology to the 5′ end of the 23S-rRNA gene and which primes in an upstream direction. This particular primer set (16SD-23SU), therefore, would amplify the region between the 16S-rRNA gene and the 23S-rRNA gene (spacer region).

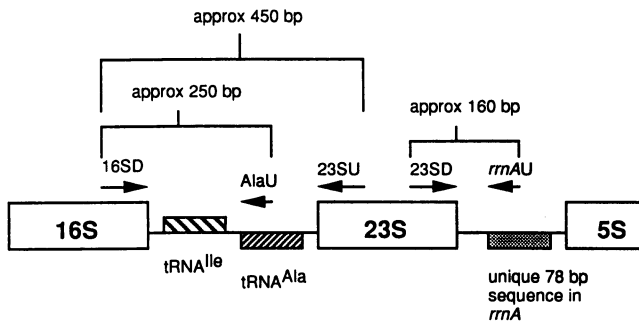

FIG. 2. Schematic diagram of ribosomal operons *rmO* and *rmA* and the placement of the PCR primers for these regions. *rmO* differs from *rmA* by not containing the 78-bp region designated *rmAU*. Figure is not to scale.

Two bands would be expected to be amplified from bacillus genomic DNA: a 250-bp band representing a spacer region without spacer tRNA genes and a 450-bp band reflecting a spacer region containing spacer tRNA genes, tRNA<sup>Ala</sup> and tRNA<sup>Ile</sup>.

In the following description of results, if a clone was deemed positive for a region, then the appropriate-size band was amplified from this clone with the primers specified (Table 2). Bands were not considered real if they were not also observed in the amplification from the bacillus genomic DNA. This was confirmed by Southern hybridization experiments as described in the following section. Bands inconsistently amplified from genomic DNA were considered anomalous.

YAC clones that overlap other YAC clones which contained rRNA and/or tRNA gene regions were tested at least with the primer sets 16SD-23SU and 5SD-16SU and/or the primers specific for the region located on the neighboring clone.

**Search for ribosomal regions.** The YAC library was screened for ribosomal operons with the primer set 16SD-23SU. From some of the clones, bands that were not amplified from bacillus genomic DNA were observed. Southern hybridizations were performed to confirm the presence or absence of a ribosomal operon (data not shown). With the clones mentioned above, the Southern hybridizations were negative; thus they also confirmed the validity of our PCR results obtained with bacillus genomic DNA.

Ribosomal regions found on 11 clones by PCR amplification of the region between the 16S- and 23S-rRNA genes (the spacer region) are described here. Figure 1 shows the placement of these regions in the YAC library, and it can be seen that some of the 10 ribosomal operons known to date have been placed on overlapping clones. This primer set also revealed ribosomal regions that contain longer spacer regions (450 rather than 250 bp) and that possibly contain tRNA genes in this region (spacer tRNAs).

In *E. coli*, there are seven rRNA operons, all of which contain tRNA genes in the spacer region. These are either the two genes for tRNA<sup>Ala</sup> and tRNA<sup>Ile</sup> or the one gene for tRNA<sup>Glu</sup> (12). Spacer tRNAs have been found in only 2 of the 10 ribosomal operons in *B. subtilis* (*rmO* and *rmA*) (33). In *B. subtilis*, the genes for tRNA<sup>Ala</sup> and tRNA<sup>Ile</sup> are found together in the spacer region. Figure 2 is a schematic diagram of the strategy for amplification within an rRNA operon with spacer tRNAs, and it shows the expected amplification results for a primer set containing a primer unique to the *rmA* operon (*rmAU*).

With the primer set 16SD-23SU, a 250-bp spacer region was amplified from nine clones, and these clones did not show any evidence of containing spacer tRNAs (Table 2). The remaining two clones, 11-237 and 15-426, which were positive for a ribosomal operon, appeared to have a longer spacer region, and further amplifications showed the presence of spacer tRNAs. Clone 11-237 contains the ribosomal operon *rmO*. This conclusion was based on the bands amplified from this clone with the primer sets 16SD-23SU, 16SD-AlaU, 23SD-*rmAU*, and *gyrAD*-16SU. Amplification with the primer set 16SD-AlaU showed the presence of a spacer tRNA-containing ribosomal operon. It also showed that this operon contained a gene for an alanine tRNA downstream of a 16S-rRNA gene. This correlates with previous results seen with *rmO* and *rmA* (33). The presence of both an isoleucine tRNA gene and an alanine tRNA gene between the 16S- and 23S-rRNA genes on clone 11-237 was verified by sequencing (see Materials and Methods).

The length of the region between the 23S- and 5S-rRNA genes is 55 bp in the *B. subtilis* ribosomal operons that have been studied (*rmO* and *rmB*) (14, 44). In *rmA*, the length of this region is approximately 135 bp, due to an additional 78-bp sequence found here (33). The following two primer sets distinguish between *rmO* and *rmA*. Primer set 23SD-*rmAU* was designed to selectively amplify a 160-bp band from *rmA* (Fig. 2 and Table 2). The primer *rmAU* was designed to hybridize to the 3' end of the 78-bp sequence, unique to *rmA*, between the 23S- and 5S-rRNA genes (33). The clone 11-237 was negative for this region, so *rmA* is not contained on this clone. Moriya et al. (31) demonstrated that *gyrA* is approximately 500 bp upstream of *rmO*. The *gyrAD*-16SU primer set amplifies the region between the genetic marker, *gyrA*, and the 16S-rRNA gene of *rmO*. Clone 11-237 was positive for this region. Thus, these results show the absence of *rmA* and the presence of *rmO* and *gyrA* on this YAC.

The primer sets used on clone 11-237 described above showed that *rmA* is located on clone 15-426. Similar results were observed when 16SD-23SU and 16SD-AlaU were used on clones 15-426 and 11-237. The opposite results were observed with 23SD-*rmAU* and *gyrAD*-16SU; amplification was observed from clone 15-426 with the former primer set but not the latter. The 16SD-23SU amplicon from 15-426, like that from 11-237, was sequenced, and the genes for two spacer tRNAs (Ile and Ala) were found. Since clones 11-237 and 15-426 overlap, it is possible that 15-426 contains both *rmA* and *rmO*, but not *gyrA* and the region upstream of *rmO* (within 500 bp). This conclusion illustrates a limitation of this technique, namely, that the copy number of amplified genes on a clone cannot be determined easily. Preliminary restriction digest data indicate that clone 15-426 contains both *rmO* and *rmA*.

Amplification results that led to the placement of *rmO* and *rmA* on clones 11-237 and 15-426, respectively, are shown in Fig. 3. Amplification was not observed with yeast genomic DNA.

**Clustered rRNA operons.** All clones found to contain ribosomal operons were tested with the primer set 5SD-16SU for the presence of clustered ribosomal operons. A strategy to find clustered ribosomal operons is illustrated in Fig. 4. Under the conditions used for this primer set, genes that are more than 2 kb apart may not be detected.

Four clones were found to contain clusters of ribosomal operons. These clones were located close to the origin in the area to which two clusters (*rrnJ-rrnW* and *rrnI-rrnH-rrnG*) had been previously mapped by genetic means (26, 46).

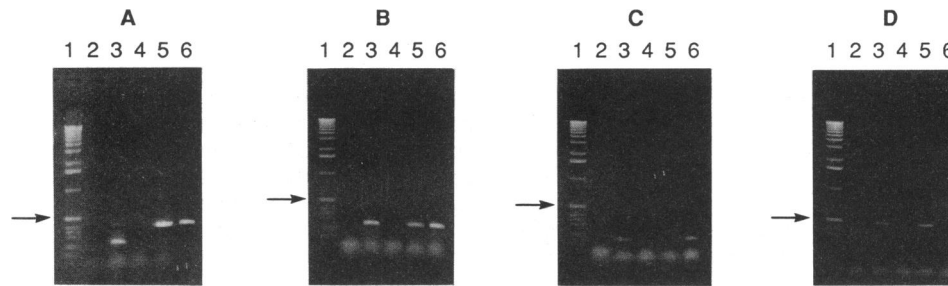

FIG. 3. Results from PCRs run with primer sets 16SD-23SU (A), 16SD-AlaU (B), 23SD-*rmA*U (C), and *gyrAD*-16SU (D). In all reactions, the lanes contained the following: 1, molecular weight markers (1-kb ladder; Bethesda Research Laboratories, Inc., Gaithersburg, Md.); 2, no DNA; 3, bacillus genomic DNA; 4, yeast genomic DNA; 5, DNA from clone 11-237; 6, DNA from clone 15-426. Arrows point to the 506-bp band, and the next four lower bands represent 396, 344, 298, and 220 bp.

Cluster *rmJ-rmW* was found on clone 15-646. This was shown by amplification results obtained with the primer sets 16SD-23SU, 5SD-16SU, 23SD-16SU, 5SD-LeuU, and ThrD-LeuU. Results obtained with the primer set 16SD-23SU showed the presence of a ribosomal operon(s) without internal-tRNA genes. Nested primer sets, 5SD-16SU and 23SD-16SU, independently showed the presence of a region between two ribosomal operons characteristic of the *rmJ-rmW* cluster (26, 46). The results obtained with 5SD-LeuU and ThrD-LeuU show the presence of the nine-tRNA gene region, reported to be associated with *rmJ* (15). The 16SD-AlaU primer set gave negative results. This primer set was tried since clone 15-646 overlaps with 15-426, which contains regions amplified by these primers (*rmO* and/or *rmA*).

The *rmJ-rmW* cluster was located on overlapping clone 11-343 as well. This was shown with primer sets 16SD-23SU, 5SD-16SU, 23SD-16SU, 5SD-LeuU, and ThrD-LeuU. The amplicons from this clone were the same as those from clone 15-646. The following primer sets gave negative results: 5SD-PheU, 5SD-GluU, LysD-PheU, and ArgD-PheU. These detect the 4-, 16-, and 21-tRNA gene regions (Table 2).

The ribosomal cluster *rmI-rmH-rmG* was also found on two overlapping clones, 15-619 and 11-415. This was determined by amplification results obtained with the primer sets 16SD-23SU, 5SD-16SU, and 23SD-16SU. The results obtained with 5SD-16SU and 23SD-16SU indicated the pres-

ence of a cluster of three ribosomal operons with regions between them of the lengths expected for the cluster *rmI-rmH-rmG* (26). Like clone 11-343, these clones were negative for the presence of the 4-, 9-, 16-, and 21-tRNA gene regions.

**Location of tRNA gene regions.** Since previous results have shown the majority of known *B. subtilis* tRNA gene regions to be associated with a ribosomal operon(s), amplifications specific for tRNA gene regions were run on the clones containing ribosomal operons.

The nine-tRNA gene region was placed on clones 15-646 and 11-343, which both contain the *rmJ-rmW* cluster. This was determined from the amplification results observed with the primer sets 5SD-LeuU and ThrD-LeuU (described above).

The 21-tRNA gene cluster has been found near 270° on the chromosome map (4) for clone 15-419 by using the primer sets 16SD-23SU, 5SD-PheU, 23SD-LeuU, ThrD-LeuU, LysD-PheU, and ArgD-PheU. The ArgD-PheU primer set specifically amplifies from the 21-tRNA gene region, while the other primer sets amplify bands of different distinguishable lengths from the 4-, 9-, 16-, and 21-tRNA gene regions (Table 2). Clone 15-502 also contains a ribosomal region, and since it overlaps with clone 15-419, it probably contains *rmB*. It does not contain the 21-tRNA gene region, since amplification was not observed with primer sets specific for regions of the 21-tRNA gene region; amplification of these regions was observed with clone 15-419 (discussed below).

One motivation for this study was to find previously unmapped tRNA gene regions, such as the 16-tRNA gene region (45). This had not been located by classical genetic approaches; however, it has recently been mapped independently by R. Rudner and colleagues and found to be associated with *rmD* (36). We found the 16-tRNA gene region to coincide in location with *rmD*, found on clone 10-4SOS (see the following section). Results obtained with the primer sets 16SD-23SU, 5SD-PheU, 23SD-LeuU, 5SD-GluU, and 5SD-LeuU led to that conclusion. Negative results for the 4- and the 21-tRNA gene clusters also confirm our finding.

The entire library was screened with the primer set LysD-PheU, which is specific for *tmY*, since this tRNA gene region is not associated with a ribosomal operon (43, 48). The four-tRNA gene region (*tmY*), which had not been mapped previously, was found only on clone 11-237 by the amplification of a 410-bp band expected from *tmY* with primer set LysD-PheU. Clone 11-237 includes the well-studied replication origin area and also contains *rmO*. Since 10 kb of this region, from just before the origin up to *rmO*,

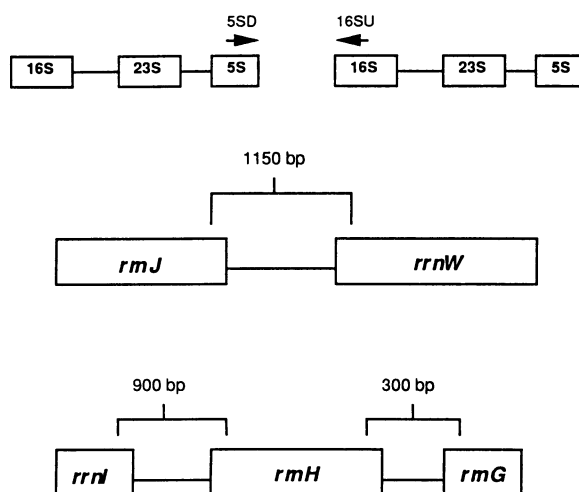

FIG. 4. Schematic diagram of primer placement designed to detect clusters of ribosomal operons. Figure is not to scale.

has been sequenced (31), this region was searched for in GenBank for the presence of *trnY* but was not found. So, *trnY* is located either upstream of the origin of replication (possibly between positions 344 [*gnt*] and 352 [*spoOJ*]) (31) or between *rrnO* and *rrnA*. On the basis of preliminary restriction digest data that place both *rrnO* and *rrnA* on clone 15-426, *trnY* is probably located upstream of the origin of replication.

**Unclustered ribosomal operons without internal-tRNA genes.** The remaining three clones were found to contain unclustered ribosomal operons without internal-tRNA genes.

On the basis of the following three pieces of evidence, clones 15-634 and 15-229 contain *rrnE*. First, amplification from 16SD-23SU revealed a ribosomal region without internal-tRNA genes, as expected for *rrnE*. Second, the overlap of the two clones is mapped to a position to which *rrnE* has been mapped previously by genetic means (28). Third, these clones do not contain amplifiable regions characteristic of any of the other tRNA gene clusters.

Ribosomal gene region *rrnD* was found on clone 10-4SOS, in its previously reported location (28) and in accordance with the results observed with the 16SD-23SU primer set. Please note that in the current YAC library, overlapping YAC clones 10-4SOS and 10-12 have been replaced by clone 15-635 (2). The presence of a ribosomal operon on 15-635 has been confirmed by Southern hybridization.

**Possibility of an 11th ribosomal operon.** An 11th ribosomal operon in the region of *rrnB* is unlikely, as previously suspected (4). The results from the present study correlate with those of studies since then concerning the number and placement of ribosomal operons (26, 27, 29, 41) and tRNA gene regions. PCR results indicate that clones 15-502 and 15-419 both contain a spacer region but that 15-502 does not contain tRNAs. Although amplification from 15-502 does not show regions specific for any of the known tRNA gene clusters, it is likely that the clone contains the ribosomal region *rrmB*, and the YAC terminates somewhere between the ribosomal region and the tRNA<sup>Leu</sup> gene, since amplification from the primer set 23SD-LeuU was not observed with this clone. However, a 700-bp band was amplified from clone 15-419 with this primer set, as expected if the 21-tRNA gene cluster is present on the YAC. Southern hybridizations were done, and the results verified those from PCRs (data not shown). The Southern hybridizations showed that clone 15-419 contains complete 16S- and 23S-rRNA genes, while clone 15-502 contains only part of a ribosomal operon (a complete 16S-rRNA gene and part of a 23S-rRNA gene), which strongly suggests that 15-502 terminates in the middle of a 23S-rRNA gene and which correlates with the observed PCR results. Therefore, the operon *rrmB* is found in the overlap between the two clones. One other important conclusion from these results is that transcription appears to occur in the same direction from the origin as bidirectional DNA replication.

**Location of the gene for P-RNA.** An enzyme important in the processing of precursor tRNAs is RNase P; its catalytic RNA component is P-RNA. Although the protein component of RNase P has been mapped to the replication origin (19, 32), the catalytic RNA component has escaped localization. Because this gene has been sequenced (6, 34), primers P-RNAD and P-RNAU (Table 1) were able to be designed. Clones 11-501 and 15-6b were found to contain the P-RNA gene. These overlapping clones were mapped with the markers *recG* and *trp*, which are found around map location 200° (2, 3, 20, 30). On the basis of map locations of other

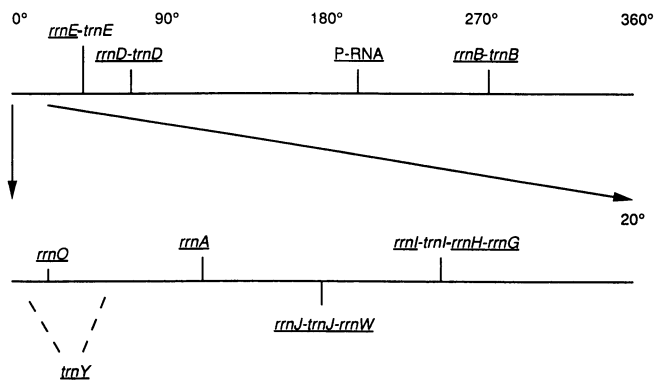

FIG. 5. Summary of current map positions of rRNA and tRNA gene regions in the *B. subtilis* genome. The regions mapped in this study are underlined. *trnY*, a 4-tRNA gene region; *trnI*, a 9-tRNA gene region; *trnJ*, a 6-tRNA gene region; *trnE*, a 2-tRNA gene region; *trnD*, a 16-tRNA gene region; *trnB*, a 21-tRNA gene region. Figure is not to scale.

markers upstream and downstream from the overlap of these two clones, it can be deduced that this overlapped region spans the region between map locations 197 and 204°.

## DISCUSSION

Results from this study demonstrate that a large number of rRNA operons in *B. subtilis* occur in the first 90° on a 360° map (Fig. 5). This correlates with findings made by others in previous mapping experiments (4, 28).

Only two ribosomal operons, *rrnO* and *rrnA*, in the bacillus genome contain spacer regions with tRNA genes. No spacer regions with sizes different from those previously known were found, since amplification from genomic DNA was not observed. Also, the previously mapped position of *gyrA* relative to *rrnO* was determined by these results, and the presence of a unique sequence in *rrnA* was verified. Ribosomal operon *rrnA* was found to be downstream of *rrnO*, as reported by others (33). Additionally, our results mapped the cluster *rrnJ-rrnW* downstream of *rrnA*, in agreement with previous findings (26, 46).

To look for unknown clustered ribosomal operons, all of the clones containing a ribosomal region, as shown by amplification with 16SD-23SU and by Southern hybridization, were amplified with the primer set 5SD-16SU (Table 2). No unknown clusters were revealed. Again, PCR limitations with the conditions used would not have allowed identification of genes more than 2 kb apart.

Known tRNA gene regions were shown to be associated with ribosomal operons, except *trnY*, which in this study and previously was found to be unassociated with a ribosomal operon (43, 48).

Regions of tRNA genes recalcitrant to mapping by classical genetic means, such as the 16-tRNA gene cluster and the 4-tRNA gene cluster, were quickly and easily assigned to a genomic region by the YAC-PCR technique. Similarly, the P-RNA gene, a very important gene which has never been mapped, was placed within a 7° region on the *B. subtilis* genome. This technique was also used to map the locus of a gene fusion, *csb42*, which identifies a gene controlled by the alternative sigma factor,  $\sigma^P$ , and which was unable to be mapped by PBS1 transduction (5, 42). These findings demonstrate the power of this technique for locating genes of



known sequences. Finally, the results concerning the rRNA and tRNA gene regions give further credibility to the placement and integrity of this YAC library, which should prove to be an invaluable tool for understanding the bacillus genome.

#### ACKNOWLEDGMENTS

We are grateful to Christopher Green for making the primers and for offering useful discussions throughout the progress of this research. We also thank Patrick Piggot for information on *B. subtilis* genetic markers and Chester Price for useful discussions and for critical reading of the manuscript.

This work was supported by National Institutes of Health grant GM29231-11. Vasco Azevedo was supported by a Brazilian Government fellowship, and the development of the YAC library was supported by EEC science grant SCI-0211.

#### REFERENCES

- Amjad, M., J. M. Castro, H. Sandoval, J.-J. Wu, M. Yang, D. J. Henner, and P. J. Piggot. 1990. An *Sfi*I restriction map of the *Bacillus subtilis* 168 genome. *Gene* 101:15-21.
- Azevedo, V., E. Alvarez, E. Zumstein, G. Damiani, V. Sgaramea, S. D. Ehrlich, and P. Serror. An ordered collection of *Bacillus subtilis* DNA segments cloned in yeast artificial chromosomes. *Proc. Natl. Acad. Sci. USA*, in press.
- Band, L., H. Shimotsu, and D. J. Henner. 1984. Nucleotide sequence of the *Bacillus subtilis* *trpE* and *trpD* genes. *Gene* 27:55-65.
- Bott, K. F., G. C. Stewart, and A. G. Anderson. 1984. Genetic mapping of cloned ribosomal RNA genes, p. 19-34. In A. T. Ganesan and J. A. Hoch (ed.), *Genetics and biotechnology of the bacilli*. Academic Press, Inc., New York.
- Boylan, S. A., A. R. Redfield, and C. W. Price. 1993. Transcription factor  $\sigma^B$  of *Bacillus subtilis* controls a large stationary-phase regulon. *J. Bacteriol.* 175:3957-3963.
- Brown, J. W., and N. R. Pace. 1992. Ribonuclease P RNA and protein subunits from bacteria. *Nucleic Acids Res.* 20:1451-1456.
- Burke, D. T., G. F. Carle, and M. V. Olson. 1987. Cloning of large segments of exogenous DNA into yeast by means of artificial chromosome vectors. *Science* 236:806-812.
- Chow, L. T., and N. Davidson. 1973. Electron microscope mapping of the distribution of ribosomal genes of the *Bacillus subtilis* chromosome. *J. Mol. Biol.* 75:265-279.
- Erdmann, V. A., and J. Wolters. 1986. Collection of published 5S, 5.8S and 4.5S ribosomal RNA sequences. *Nucleic Acids Res.* 14(Suppl.):r1-r59.
- Ferrari, E., D. J. Henner, and J. A. Hoch. 1981. Isolation of *Bacillus subtilis* genes from a Charon 4A library. *J. Bacteriol.* 146:430-432.
- Ferrari, F. A., A. Nguyen, D. Lang, and J. A. Hoch. 1983. Construction and properties of an integrable plasmid for *Bacillus subtilis*. *J. Bacteriol.* 154:1513-1515.
- Fournier, M. J., and H. Ozeki. 1985. Structure and organization of the transfer ribonucleic acid genes of *Escherichia coli* K-12. *Microbiol. Rev.* 49:379-397.
- Green, C. J., G. C. Stewart, M. A. Hollis, B. S. Vold, and K. F. Bott. 1985. Nucleotide sequence of the *Bacillus subtilis* ribosomal RNA operon, *rnmB*. *Gene* 37:261-266.
- Green, C. J., and B. S. Vold. 1983. Sequence analysis of a cluster of twenty-one tRNA genes in *Bacillus subtilis*. *Nucleic Acids Res.* 11:5763-5774.
- Green, C. J., and B. S. Vold. 1992. A cluster of nine tRNA genes between ribosomal gene operons in *Bacillus subtilis*. *J. Bacteriol.* 174:3147-3151.
- Green, C. J., and B. S. Vold. 1993. tRNA, tRNA processing, and aminoacyl-tRNA synthetases, p. 683-698. In A. L. Sonenshein, J. A. Hoch, and R. Losick (ed.), *Bacillus subtilis* and other gram-positive bacteria. American Society for Microbiology, Washington, D.C.
- Gutell, R. R., and G. E. Fox. 1988. A compilation of large subunit RNA sequences presented in a structural format. *Nucleic Acids Res.* 16(Suppl.):r175-r269.
- Haldenwang, W. G., C. D. B. Banner, J. F. Ollington, R. Losick, J. A. Hoch, M. B. O'Connor, and A. L. Sonenshein. 1980. Mapping a cloned gene under sporulation control by insertion of a drug resistance marker into the *Bacillus subtilis* chromosome. *J. Bacteriol.* 142:90-98.
- Hansen, F. G., E. B. Hansen, and T. Atlung. 1985. Physical mapping and nucleotide sequence of the *rnpA* gene that encodes the protein component of ribonuclease P in *Escherichia coli*. *Gene* 38:85-93.
- Henner, D. J., L. Band, and H. Shimotsu. 1984. Nucleotide sequence of the *Bacillus subtilis* tryptophan operon. *Gene* 34:169-177.
- Henner, D. J., and J. A. Hoch. 1980. The *Bacillus subtilis* chromosome. *Microbiol. Rev.* 44:57-82.
- Hsiao, K. 1991. A fast and simple procedure for sequencing double stranded DNA with Sequenase. *Nucleic Acids Res.* 19:2787.
- Hutchinson, K. W., and H. O. Halvorson. 1980. Cloning of randomly sheared DNA fragments from a  $\phi$ 105 lysogen of *Bacillus subtilis* identification of prophage-containing clones. *Gene* 8:267-278.
- Huysmans, E., and R. De Wachter. 1986. Compilation of small ribosomal subunit RNA sequences. *Nucleic Acids Res.* 14(Suppl.):r73-r118.
- Itaya, M., and T. Tanaka. 1991. Complete physical map of the *Bacillus subtilis* 168 chromosome constructed by a gene-directed mutagenesis method. *J. Mol. Biol.* 220:631-648.
- Jarvis, E. D., R. L. Widom, G. LaFauci, Y. Setoguchi, I. R. Richter, and R. Rudner. 1988. Chromosomal organization of rRNA operons in *Bacillus subtilis*. *Genetics* 120:625-635.
- Kobayashi, H., and S. Osawa. 1982. The number of 5S rRNA genes in *Bacillus subtilis*. *FEBS Lett.* 141:161-163.
- LaFauci, G., R. L. Widom, R. L. Eisner, E. D. Jarvis, and R. Rudner. 1986. Mapping of rRNA genes with integrable plasmids in *Bacillus subtilis*. *J. Bacteriol.* 165:204-214.
- Loughney, K., E. Lund, and J. E. Dahlberg. 1982. tRNA genes are found between the 16S and 23S rRNA genes in *Bacillus subtilis*. *Nucleic Acids Res.* 10:1607-1624.
- Mazza, G., A. Forunato, E. Ferrari, U. Canosi, A. Falaschi, and M. Polsinelli. 1975. Genetic and enzymic studies on the recombination process in *Bacillus subtilis*. *Mol. Gen. Genet.* 136:9-30.
- Moriya, S., N. Ogasawara, and H. Yoshikawa. 1985. Structure and function of the region of the replication origin of the *Bacillus subtilis* chromosome. III. Nucleotide sequence of some 10,000 base pairs in the origin region. *Nucleic Acids Res.* 13:2251-2265.
- Ogasawara, N., S. Moriya, K. von Meyenburg, F. G. Hansen, and H. Yoshikawa. 1985. Conservation of genes and their organization in the chromosomal replication origin region of *Bacillus subtilis* and *Escherichia coli*. *EMBO J.* 4:3345-3350.
- Ogasawara, N., S. Moriya, and H. Yoshikawa. 1983. Structure and organization of rRNA operons in the region of the replication origin of the *Bacillus subtilis* chromosome. *Nucleic Acids Res.* 11:6301-6318.
- Reich, C., K. J. Gardiner, G. J. Olsen, B. Pace, T. L. Marsh, and N. R. Pace. 1986. The RNA component of the *Bacillus subtilis* RNase P. Sequence, activity, and partial secondary structure. *J. Biol. Chem.* 261:7888-7893.
- Reysenbach, A.-L., L. J. Giver, G. S. Wickham, and N. R. Pace. 1992. Differential amplification of rRNA genes by polymerase chain reaction. *Appl. Environ. Microbiol.* 58:3417-3418.
- Rudner, R., A. Chevrestt, S. R. Buchholz, B. Studamire, A.-M. White, and E. D. Jarvis. 1993. Two tRNA gene clusters associated with rRNA operons *rnmD* and *rnmE* in *Bacillus subtilis*. *J. Bacteriol.* 175:503-509.
- Sambrook, J., E. F. Fritsch, and T. Maniatis. 1989. *Molecular cloning: a laboratory manual*, 2nd ed. Cold Spring Harbor Laboratory Press, Cold Spring Harbor, N.Y.
- Sherman, F. 1991. Getting started with yeast, p. 7. In C. Guthrie and G. R. Fink (ed.), *Guide to yeast genetics and molecular biology*. Academic Press, New York.
- Southern, E. M. 1975. Detection of specific sequences among



- DNA fragments separated by gel electrophoresis. *J. Mol. Biol.* **98**:503–517.
40. Sprinzl, M., T. Hartmann, F. Meissner, J. Moll, and T. Vorderwülbecke. 1987. Compilation of tRNA sequences and sequences of tRNA genes. *Nucleic Acids Res.* **15**(Suppl.):r53–r188.
  41. Stewart, G. C., F. E. Wilson, and K. F. Bott. 1982. Detailed physical mapping of the ribosomal RNA genes of *Bacillus subtilis*. *Gene* **19**:153–162.
  42. Varón, D., S. A. Boylan, K. Okamoto, and C. W. Price. 1993. *Bacillus subtilis gtaB* encodes UDP-glucose pyrophosphorylase and is controlled by stationary-phase transcription factor  $\sigma^B$ . *J. Bacteriol.* **175**:3964–3971.
  43. Vold, B. S. 1985. Structure and organization of genes for transfer ribonucleic acid in *Bacillus subtilis*. *Microbiol. Rev.* **49**:71–80.
  44. Wawrousek, E. F., and J. N. Hansen. 1983. Structure and organization of a cluster of six tRNA genes in the space between tandem ribosomal RNA gene sets in *Bacillus subtilis*. *J. Biol. Chem.* **258**:291–298.
  45. Wawrousek, E. F., N. Narasimhan, and J. N. Hansen. 1984. Two large clusters with thirty-seven transfer RNA genes adjacent to ribosomal RNA gene sets in *Bacillus subtilis*. *J. Biol. Chem.* **259**:3694–3702.
  46. Widom, R. L., E. D. Jarvis, G. LaFauci, and R. Rudner. 1988. Instability of rRNA operons in *Bacillus subtilis*. *J. Bacteriol.* **170**:605–610.
  47. Wilson, F. E., J. A. Hoch, and K. Bott. 1981. Genetic mapping of a linked cluster of ribosomal ribonucleic acid genes in *Bacillus subtilis*. *J. Bacteriol.* **148**:624–628.
  48. Yamada, Y., M. Ohki, and H. Ishikura. 1983. The nucleotide sequence of *Bacillus subtilis* tRNA genes. *Nucleic Acids Res.* **11**:3037–3045.