



**HAL**  
open science

# Automatic analyzis of droplet impact by high speed imaging

Thomas Decourselle, Frédéric Cointault, Ludovic Journaux, Fan Yang

► **To cite this version:**

Thomas Decourselle, Frédéric Cointault, Ludovic Journaux, Fan Yang. Automatic analyzis of droplet impact by high speed imaging. 1. RHEA International Conference on Robotics and associated High-technologies and Equipment for agriculture, Sep 2012, Pisa, Italy. hal-02747223

**HAL Id: hal-02747223**

**<https://hal.inrae.fr/hal-02747223v1>**

Submitted on 3 Jun 2020

**HAL** is a multi-disciplinary open access archive for the deposit and dissemination of scientific research documents, whether they are published or not. The documents may come from teaching and research institutions in France or abroad, or from public or private research centers.

L'archive ouverte pluridisciplinaire **HAL**, est destinée au dépôt et à la diffusion de documents scientifiques de niveau recherche, publiés ou non, émanant des établissements d'enseignement et de recherche français ou étrangers, des laboratoires publics ou privés.

# Proceedings of the first International Conference on Robotics and associated High-technologies and Equipment for agriculture

Applications of automated systems and robotics for crop protection in sustainable precision agriculture

(RHEA-2012) Pisa, Italy - September 19-21, 2012



Edited by  
Andrea Peruzzi





**PROCEEDINGS OF THE FIRST INTERNATIONAL  
CONFERENCE ON ROBOTICS AND ASSOCIATED  
HIGH-TECHNOLOGIES AND EQUIPMENT  
FOR AGRICULTURE**

Applications of automated systems and robotics for crop protection  
in sustainable precision agriculture  
(RHEA-2012)

Pisa, Italy  
September 19-21, 2012

Edited by  
Andrea Peruzzi





The research leading to these results has received funding from the European Union's Seventh Framework Programme [FP7/2007-2013] under Grant Agreement no 245986

The views expressed in this document are entirely those of the authors and do not engage or commit the European Commission or the editors in any way.

*Layout and Graphic*

Uliva Foà

*Proceedings are available at:*

<http://www.rhea-project.eu>

<http://www.avanzi.unipi.it/>

<http://www.edizioniplus.it/inglese/aspfiles/index.asp>

*Editor*

Andrea Peruzzi (*University of Pisa*)

*General chairperson*

Andrea Peruzzi (*University of Pisa*)

*General co-chairperson*

Pablo Gonzalez-de-Santos (*CSIC-Centre for Automation and Robotics*)

© Copyright 2012 by Pisa University Press srl  
Società con socio unico Università di Pisa  
Capitale Sociale Euro 20.000,00 i.v. - Partita IVA 02047370503  
Sede legale: Lungarno Pacinotti 43/44 - 56126, Pisa  
Tel. + 39 050 2212056 Fax + 39 050 2212945  
e-mail: [press@unipi.it](mailto:press@unipi.it)

*Member of*



ISBN 978-88-6741-021-7

Le fotocopie per uso personale del lettore possono essere effettuate nei limiti del 15% di ciascun volume/fascicolo di periodico dietro pagamento alla SIAE del compenso previsto dall'art. 68, commi 4 e 5, della legge 22 aprile 1941 n. 633.

Le riproduzioni effettuate per finalità di carattere professionale, economico o commerciale o comunque per uso diverso da quello personale possono essere effettuate a seguito di specifica autorizzazione rilasciata da AIDRO, Corso di Porta Romana n. 108, Milano 20122, e-mail [segreteria@aidro.org](mailto:segreteria@aidro.org) e sito web [www.aidro.org](http://www.aidro.org)

## **INTERNATIONAL SCIENTIFIC COMMITTEE**

**Angela RIBEIRO**, CSIC-CAR, Spain  
**Maria GUIJARRO**, University Complutense of Madrid, Spain  
**Cesar FERNANDEZ-QUINTANILLA**, CSIC-ICA, Spain  
**Francisca LOPEZ-GRANADOS**, CSIC-IAS, Spain  
**Slobodanka TOMIC**, FTW, Austria  
**Gonzalo PAJARES**, University Complutense of Madrid, Spain  
**Pilar BARREIRO**, Polytechnic University of Madrid, Spain  
**Antonio BARRIENTOS**, Polytechnic University of Madrid, Spain  
**Marco VIERI**, University of Florence, Italy  
**Gilles RABATEL**, CEMAGREF, France  
**Nicola TOMATIS**, Bluebotics, Switzerland  
**Yvan BOURQUIN**, Cyberbotics, Switzerland  
**Manuel PEREZ-RUIZ**, AGROSAP, Spain  
**Michael BRANDSTÖTTER**, CogVIs, Austria  
**Bart MISSOTTEN**, CNH, Belgium  
**Gennaro PETILLO**, CM, Italy  
**Marco MAZZONCINI**, University of Pisa, Italy  
**Paolo BARBERI**, Scuola Superiore Sant'Anna, Pisa  
**Xavier P. BURGOS-ARTIZZU**, California Inst. of Technology, USA  
**Alberto TELLAECHÉ**, Tekniker, Spain  
**Alexandre ESCOLÀ**, University of Lleida, Spain

## **LOCAL ORGANIZING AND SCIENTIFIC COMMITTEE**

**Michele RAFFAELLI**, University of Pisa, Italy  
**Marco FONTANELLI**, University of Pisa, Italy  
**Christian FRASCONI**, University of Pisa, Italy  
**Daniele ANTICHI**, University of Pisa, Italy  
**Marco RIMEDIOTTI**, University of Florence, Italy  
**Daniele SARRI**, University of Florence, Italy  
**Luisa MARTELLONI**, University of Pisa, Italy  
**Marco GINANNI**, University of Pisa, Italy  
**Silvia BARONI**, University of Pisa, Italy  
**Roberta DEL SARTO**, University of Pisa, Italy  
**Calogero PLAIA**, University of Pisa, Italy  
**Riccardo LISCI**, University of Florence, Italy  
**Angelà CANNIZZO**, University of Florence, Italy

## **Introduction**

### The RHEA Project

The availability of new technologies, such as positioning systems (GPS), geographic information systems (GIS), sensors, automation of agricultural machinery, and high resolution image sensing has made possible an accurate management of agricultural land. Thus, the concept of Precision Agriculture has come out as the management strategy that uses information technologies to collect and process data from multiple sources in order to facilitate decisions associated with crop production.

The Seventh Framework Programme project RHEA “Robot Fleets for Highly Effective Agricultural and Forestry Management” (FP7-NMP N. 245986) focuses on the design, development, and testing of a new generation of automatic and robotic systems for both chemical and physical –mechanical and thermal– effective weed management for agriculture and forestry, and covers a large variety of European products including agriculture wide row crops, close row crops and woody perennials.

RHEA aims at diminishing the use of agricultural and forestry chemical inputs, improving crop quality, health and safety for humans, and reducing production costs by means of sustainable crop management using a fleet of heterogeneous robots –ground and aerial– equipped with advanced perception systems, enhanced end-effectors and improved decision control algorithms.

The RHEA consortium joints a number of multidisciplinary, experienced researchers capable of improving individual scientific knowledge and sums up their individual efforts in a holistic manner to give birth to a new manner of applying automatic systems to agriculture and forestry crops with an important impact in improving the economy and environment as well as in maintaining the sustainability of rural areas by launching new technological jobs.

*Pablo Gonzalez-de-Santos*  
RHEA Project coordinator

The RHEA consortium is formed by:

	<b>Agencia Estatal Consejo Superior de Investigaciones Científicas (CSIC)</b> (Coordinator) Spain <i>Centro de Automática y Robotica</i> <i>Instituto de Ciencias Agrarias</i> <i>Instituto de Agricultura Sostenible</i>
(CSIC-CAR CSIC-ICA CSIC-IAS)	
	<b>CogVis GmbH (CV)</b> Austria
	<b>Forschungszentrum Telekommunikation Wien Ltd. (FTW)</b> Austria
	<b>Cyberbotics Ltd (CY)</b> Switzerland
	<b>Università di Pisa (UP)</b> Italy
	<b>Universidad Complutense de Madrid (UCM)</b> Spain
	<b>Tropical (TRO)</b> Greece
	<b>Soluciones Agrícolas de Precisión S.L. (SAP)</b> Spain
	<b>Universidad Politécnica de Madrid (UPM)</b> Spain
POLITÉCNICA UPM-EIA UPM-EII	ETS Ingenieros Agrónomos ETS Ingenieros Industriales
	<b>AirRobot GmbH &amp; Co. KG (AR)</b> Germany
	<b>Università degli Studi di Firenze (UF)</b> Italy
	<b>Centre National du Machinisme Agricole, du Génie Rural, des Eaux et des Forêts - CEMAGREF (CE)</b> France
	<b>Case New Holland Belgium N.V. (CNH)</b>
CNH-B CNH-F	<i>Case New Holland Belgium N.V. Belgium</i> <i>Case New Holland Belgium S.A. France</i>
	<b>Bluebotics S.A. (BL)</b> Switzerland
	<b>CM Srl (CM)</b> Italy

## Foreword

The papers reported in the proceedings of this First International Conference on: “Robotics and associated High-technologies and Equipment for Agriculture - *Applications of automated systems and robotics for crop protection in sustainable precision agriculture*”, are partly (about 50%) the result of the work developed by the RHEA consortium throughout the first two years of the RHEA project (Robot fleets for highly effective agriculture and forestry management-FP7-NMP 245986) and partly concern with the results obtained in other researches carried out by scientists “external” to the RHEA Project, but involved in similar subjects of study. However, the quality of the papers presented is really high, thus these proceedings are characterised by a high scientific relevance of the state of the art of the research subjects related to the “*Applications of automated systems and robotics for crop protection in sustainable precision agriculture*”.

In the call for papers researchers and scientists from all Countries of the world were invited to participate to the Conference, presenting ideas, research results, works in progress and system demonstrations related to two main themes including six main topics that were successively shared in twelve different sessions.

**Theme (1), “Strategies and tools for precision farming”** included three main topics: *topic 1.1 “Automated machines for chemical weed control”, topic 1.2 “Automated machines for physical weed control”* and *topic 1.3 “Automated machines for tree crop protection”* (this latter shared in two different sessions: Session 1: Equipment innovation and Session 2: Device innovation).

**Theme (2), “Automation and robotics for precision agriculture”** included three main topics: *topic 2.1 “Design and control of automated agricultural vehicles and systems* (shared in: Session 1: Control algorithms for agricultural mobile robots; Session 2: Manipulation in agricultural tasks; Session 3: Sensorial systems for agriculture; Session 4: New trends in mobile robotics in agriculture), *topic 2.2 “Computer vision and image analysis in agricultural processes”* (shared in Session 1: Advanced procedures for image analysis of remotely sensed data in cropping systems; Session 2: Weed-Crop discrimination; Session 3: Advanced sensors systems in agricultural environments) and *topic 2.3 “ICT technologies in precision agriculture”*.

The Conference that was held in the very beautiful city of Pisa, Italy, on September 19, 20 and 21, 2012, was attended by more than 70 participants coming from 13 different European, North American and African Countries (Austria, Belgium, Cameroon, Denmark, France, Germany,

Greece, Italy, Norway, Slovenia, Spain, Switzerland and USA) that presented more than 50 papers.

Thus, I think that the objectives of this Conference that were both to disseminate the RHEA project results and to have more knowledge of the results obtained in other research projects on similar subjects motivating discussion, new insight and experimentation, were plenty satisfied.

As General Chairperson, organizer and editor of these proceedings, I want finally to thank very much all the speakers, authors and attendees for their contributions to this first RHEA International Conference that will be followed by a second International Conference in 2014 at the end of the RHEA Project.

Andrea Peruzzi – *University of Pisa*  
RHEA Conference General Chairman  
and Editor of the Proceedings



# CONTENTS

## THEME 1: STRATEGIES AND TOOLS FOR PRECISION AGRICULTURE

*The EU Framework Directive on sustainable pesticide use: prospects for site-specific weed management*  
Paolo Bàrberi ..... pag. 15

### Topic 1.1 Automated machines for chemical weed control

*Design, development and lab evaluation of a weed control sprayer to be used in robotic system*  
Jacob Carballido, Manuel Perez-Ruiz and Juan Agüera ..... pag. 23

*Field robots for research and development in site-specific weed management – Norwegian activities*  
Therese W. Berge, Trygve Utstumo and Jan Netland ..... pag. 31

*Hurdles to overcome in the development of spatially variable weed control (patch spraying)*  
Peter Lutman ..... pag. 35

*Robotics for weed control: I-WEED ROBOT for a specific spraying*  
Christelle Gee, Eric Busvelle, Ghislain Salis, Sylvain Villette,  
Jean-Noël Paoli and  
Gawain Jones ..... pag. 41

### Topic 1.2 Automated machines for physical weed control

*A new prototype to perform precision treatments of activated steaming to kill weed seed before organic sown vegetable planting*  
Andrea Peruzzi, Christian Frasconi, Luisa Martelloni,  
Marco Fontanelli and Michele Raffaelli ..... pag. 49

*Application of precision flaming to maize and garlic in the RHEA PROJECT*  
Peruzzi Andrea, Frasconi Christian, Luisa Martelloni,  
Marco Fontanelli and Michele Raffaelli ..... pag. 55

*Effect of flaming and cultivation on weed control and yield in corn and soybean*  
Avishek Datta, Strahinja Stepanovic, Brian Neilson,  
Chris Bruening, George Gogos and Stevan Knezevic ..... pag. 61

*Sensor based LPG management system for application of precision flaming*  
Michele Raffaelli, Marco Fontanelli, Christian Frasconi,  
Luisa Martelloni and Andrea Peruzzi ..... pag. 67

### **Topic 1.3 Automated machines for tree crop protection**

#### **Session 1: Equipment innovation**

##### ***Canopy optimised sprayer development within crops EU PROJECT***

Marko Hočevar, Tone Godeša, Brane Širok, Aleš Malneršič  
and Viktor Jejič ..... pag. 75

##### ***Electronic canopy characterization and variable rate application in Precision Fructiculture and Viticulture***

Alexandre Escolà, Joan Ramon Rosell, Emilio Gil, Ricardo Sanz,  
Jaume Arnó, Ignacio Del Moral, Jordi Llorens, Joan Masip,  
Eduardo Gregoria and Santiago Planas ..... pag. 81

##### ***Sustainable plant protection in fruit growing: the development of a Crop Adapted Spray Application system***

Paolo Marucco, Paolo Balsari, Grzegorz Doruchowski,  
Jan Van de Zande, Marcel Wenneker and Mario Tamagnone ..... pag. 87

##### ***The innovative RHEA airblast sprayer for tree crop treatment***

Marco Vieri, Riccardo Lisci, Marco Rimediotti and Daniele Sarri ..... pag. 93

#### **Session 2: Device innovation**

##### ***Automatic diseases detection in grapevine under field conditions***

Roberto Oberti, Paolo Tirelli, Massimo Marchi, Marcello Iriti  
and Alberto Borghese ..... pag. 101

##### ***Close range precision spraying airflow/plant interaction***

Aleš Malneršič, Marko Hočevar, Brane Širok, Massimo Marchi,  
Paolo Tirelli and Roberto Oberti ..... pag. 107

##### ***RHEA airblast sprayer: studies on intermittent flow rate nozzle for VRT***

Marco Rimediotti, Daniele Sarri, Riccardo Lisci  
and Marco Vieri ..... pag. 113

##### ***The RHEA airblast sprayer: studies on a continuous mixer for the VRA***

Daniele Sarri, Riccardo Lisci, Marco Rimediotti and Marco Vieri ..... pag. 119

### **THEME 2: AUTOMATION AND ROBOTICS FOR PRECISION AGRICULTURE**

#### ***Automation and Robotics for precision agriculture: state of the art and perspectives***

Paolo Gay ..... pag. 127

### **Topic 2.1 Design and control of automated agricultural vehicles and systems**

#### **Session 1: Control algorithms for agricultural mobile robots**

##### ***Algorithms, for path following and planning, for agricultural robots***

Christian Correa, Constantino Valero, Pilar Barreiro and Lorenzo Vasquez ..... pag. 145

##### ***Integrating robot positioning controllers in the SEARFS simulation environment***

Luis Emmi, Gonzalo Pajares and Pablo Gonzalez-De-Santos ..... pag. 151

*Model Predictive Control of the Yaw Dynamics of an Autonomous Tractor*  
Erkan Kayacan, Erdal Kayacan, Herman Ramon and Wouter Saeys ..... pag. 157

*Search strategies and the automated control of plant diseases*  
Juan Duque Rodríguez, Javier Gutiérrez López, Valeriano Méndez Fuentes,  
Pilar Barreiro Elorza, David Gómez-Ullate, Carlos Mejía-Monasterio ..... pag. 163

### **Session 2: Manipulation in agricultural tasks**

*A software framework for agricultural and forestry robotics*  
Thomas Hellström and Ola Ringdahl ..... pag. 171

*Development of a multipurpose agricultural manipulator*  
Julian Pfaff, Joerg Baur, Heinz Ulbrich and Thomas Villgrattner ..... pag. 177

*Evaluation of Field Test of Harvesting System for Picking Dates fruits Based on Robotic Arm*  
Abdulrahman Aljanobi and Abdulwahed Abukarima ..... pag. 183

*Vision System based on RGB filter to guide autonomous vehicles in greenhouses*  
Victoria Plaza, Francisco Rodriguez and Ramon Gonzalez ..... pag. 189

### **Session 3: Sensorial systems for agriculture**

*Evaluating the performance of a low-cost GPS in precision agriculture applications*  
Kjeld Jensen, Morten Larsen and Rasmus N. Jørgensen ..... pag. 197

*Reliable low cost sensors and systems for the navigation of autonomous robots in pot crop nurseries*  
Lorenzo Comba, Sergio Finéz Martínez, Paolo Gay  
and Davide Ricauda Aimonino ..... pag. 203

*Vibration effects of bumper suspension system on pipeline sensor-based platform for soil water monitoring*  
Ioannis Gravalos, Spyros Loutridis, Dimitrios Moshou,  
Theodoros Gialamas, Dimitrios Kateris, Zisis Tsiropoulos  
and Panagiotis Xyradakis ..... pag. 209

### **Session 4: New trends in mobile robotics in agriculture**

*Hardware architecture design for navigation and precision control in autonomous agricultural vehicles*  
Luis Emmi and Pablo Gonzalez-De-Santos ..... pag. 217

*Monitoring of sugar cane plantations by a micro- unmanned aerial vehicle*  
Tania Luna Laura, Armando Sanca Sanca, João Paulo Ferreira, Guimarães,  
Michel Santana de Deus, Alessandro N. Schildt, Pablo Javier Alsina  
and Adelardo Medeiros ..... pag. 223

*Non invasive moisture measurement in agricultural field using a rolling spherical robot*  
Juan D. Hernández, David Sanz, Jorge Barrientos,  
João Valente, Jaime Del Cerro and Antonio Barrientos ..... pag. 229

<i>Risk analysis for UAV safe operations: A rationalization for an agricultural environment</i>	
David Sanz, Joao Valente, Jaime Del Cerro, Miguel Angel De Frutos, Juan Jesus Roldan and Antonio Barrientos.....	pag. 235
<b>Topic 2.2 Computer vision and image analysis in agricultural processes</b>	
<b><u>Session 1: Advanced procedures for image analysis of remotely sensed data in cropping systems</u></b>	
<i>A weed/crop segmentation method based on fuzzy k-means clustering for aerial images</i>	
P. Javier Herrera, Ana I. de Castro, Francisca López-Granados, Montserrat Jurado-Expósito and Ángela Ribeiro .....	pag. 243
<i>Discrimination of crop rows using object-based approaches in UAV images for early site-specific weed management in maize fields</i>	
José Manuel Peña-Barragán, Maggi Kelly, Ana-Isabel de Castro and Francisca Lopez-Granados .....	pag. 249
<i>Improving of georeferencing accuracy in UVA remote imagery</i>	
Juan Jose Caballero-Novella, Francisca Lopez-Granados, David Gomez-Candon, Ana Isabel De-Castro and Luis Garcia-Torres .....	pag. 255
<i>Mosaicking UAV imagery for precision agriculture purposes: effect of flying altitude</i>	
David Gomez-Candon, José M. Peña-Barragán, Ana I. De-Castro, Montserrat Jurado-Expósito and Francisca López-Granados.....	pag. 261
<b><u>Session 2: Weed-Crop discrimination</u></b>	
<i>Automatic mosaicking of very high spatial resolution UAV multispectral images for precision agriculture: Test of MICMAC freeware</i>	
Sylvain Labbé, David Gómez-Candón, Ghina El-Natour, José Dorado, César Fernández-Quintanilla, Francisca López-Granados, José M. Peña- Barragán, Ana I. De Castro, Jorge Torres-Sánchez, Gilles Rabatel.....	pag. 269
<i>Evaluation of features for context based crop classification</i>	
Henrik Skov Midtiby and Rasmus Nyholm Jørgensen.....	pag. 27
<i>Real-time weed/crop discrimination through fast image registration</i>	
Xavier P. Burgos-Artizzu, Piotr Dollar, Angela Ribeiro and Pietro Perona.....	pag. 281
<i>Ultrasonic measurements for weed detection in cereal crops</i>	
Dionisio Andújar, Martin Weis and Roland Gerhards .....	pag. 287
<i>Weed mapping in cotton using proximal and remote sensing under GIS environment</i>	
A. Papadopoulos and D. Chachalis .....	pag. 293
<b><u>Session 3: Advanced sensors systems in agricultural environments</u></b>	

<i>An empirical study on the suitability of SURF algorithm for features detection and video stabilization in crop fields</i>	
Nadir Sainz-Costa, Xavier P. Burgos-Artizzu, P. Javier Herrera and Angela Ribeiro .....	pag. 301
<i>Automatic analysis of droplet impact by high speed imaging</i>	
Thomas Decourselle, Frédéric Cointault, Ludovic Journaux and Fan Yang.....	pag. 307
<i>In-field Accurate Apple Fruit Detection using Standard Digital Camera and Robust Image Analysis Processing</i>	
Christophe Erhet, Guizard Christophe, Gobrecht Alexia and Bouniol Matthieu .....	pag. 313
<i>Influence of the vision system pitch angle on crop and weeds detection accuracy</i>	
José Miguel Guerrero, Juan Romeo, Luis Emmi, Martín Montalvo, María Guijarro, . Gonzalo Pajares and Pablo Gonzalez de Santos .....	pag. 319
<i>Online dose optimization applied on a tree mass through a laser device</i>	
Miguel Garrido, Valeriano Méndez, Constantino Valero, Christian Correa, Alejandro Torre and Pilar Barreiro.....	pag. 325
<i>Embedded vision system for real-time fruit detection and tracking</i>	
Marcel Tresancez, Mercè Teixidó, Davinia Font, Tomàs Pallejà and Jordi Palacin.....	pag. 331
<b>Topic 2.3 ICT technologies in precision agriculture</b>	
<i>Exploring the effect of turning maneuvers on the multi-path planning of a robot fleet in agricultural tasks</i>	
Jesus Conesa, Angela Ribeiro, Dionisio Andujar, Cesar Fernandez-Quintanilla and Jose Dorado .....	pag. 339
<i>ICT based Innovative Farmer Education Programme to bridge Information and Knowledge gap of Agriculture: A Case Study in Sri Lanka</i>	
N.P. Vidanapathirana, K. Hirimburegama and W.K. Hirimburegama .....	pag. 345
<i>User Interactions with Robotic Fleets for Intelligent Agriculture</i>	
Slobodanka Tomic and Domagoj Drenjanac.....	pag. 351
<i>Self-Organizing Multi-Technology Communication for Agriculture Robotic Fleets</i>	
Thomas Hinterhofer and Slobodanka Tomic.....	pag. 357
<i>WEDEX- a weed expert system for a robot fleet in agriculture</i>	
Cesar Fernandez-Quintanilla, Jose Dorado, Jesus Conesa-Muñoz and Angela Ribeiro .....	pag. 363



**Theme 1:**  
Strategies and tools  
for precision agriculture









**First RHEA International Conference on  
Robotics and associated High-technologies  
and Equipment for Agriculture**  
Hosted by the University of Pisa  
Pisa, Italy, September 19-20-21, 2012



## **THEME 1 - Strategies And Tools For Precision Agriculture**

### **THE EU FRAMEWORK DIRECTIVE ON SUSTAINABLE PESTICIDE USE: PROSPECTS FOR SITE-SPECIFIC WEED MANAGEMENT**

**BÀRBERI P.<sup>1</sup>**

<sup>1</sup>Institute of Life Sciences, Scuola Superiore Sant'Anna, Piazza Martiri della Libertà 33, 56127 Pisa PI, Italy, barberi@sssup.it

**Keywords:** *herbicide, IPM, pesticide use, precision agriculture, sustainable agriculture*

#### **ABSTRACT**

The sustainable use of pesticides was one of the seven Thematic Strategies to be addressed in the Sixth EU Environment Action Programme (2002-2012). The EU Framework Directive on Sustainable Pesticide Use was released in October 2009 to meet this challenge. The key issues of the Directive are: (a) the deployment of National Action Plans by 14 December 2012, (b) training and certification of all professional users dealing with pesticides, (c) adoption of IPM systems and methods by all EU farmers from 1 January 2014. Site-specific weed management (SSWM) seems in agreement with the objectives of the Directive, i.e. to achieve a significant reduction in risks and use of pesticides while maintaining an adequate level of crop protection. At the moment, the main limitations of SSWM are the unsatisfactory precision of weed species identification, high solution costs and the lack of adequately trained farmers or technicians. Some technological innovations, e.g. in remote sensing equipment, show promising perspectives to improve weed identification. Technological advancement in sensors and robots should reduce machinery and application costs. Training of professionals on SSWM concepts and tools is possible and desirable. These are already well in line with three out of eight IPM principles set forth in the Directive, whereas additional four principles could be embraced should monitoring and application technologies for SSWM improve. Overall, SSWM seems well suited to fit into future European IPM systems, but its use will likely be limited to large cropland and commodities unless considerable



reduction in equipment and systems cost and development of more user-friendly solutions occur. A weak point is that SSWM is not explicitly mentioned among the priority themes for training of professionals, as to Annex I of the Directive.

## **INTRODUCTION**

Pesticide use reduction has long been an objective of agricultural and environmental policies in several EU Member States. The Sixth Environment Action Programme (2002-2012) indicated the sustainable use of pesticides as one of the seven Thematic Strategies to be addressed. To meet this challenge, in October 2009 the European Commission released a Framework Directive on Sustainable Pesticide Use (Directive 2009/128/EC) – hereafter referred to as ‘the Directive’, as part of the so-called ‘Pesticide Package’, which also includes (a) Regulation (EC) No. 1107/2009 on the Placing of Plant Protection Products on the Market; (b) Regulation (EC) No. 1185/2009 on Statistics on Pesticides and (c) Directive 2009/127/EC on Machinery for Pesticide Application. The full set of these legislative documents can be accessed at:

[http://www.endure-network.eu/index.php/endure/about\\_ipm/european\\_commission\\_documents](http://www.endure-network.eu/index.php/endure/about_ipm/european_commission_documents).

Within the context of precision agriculture, site-specific weed management (SSWM) has the purpose of reducing herbicide use through optimisation of herbicide applications and doses based upon the outcome of field or aerial weed scouting. This results in spatially selective spraying (i.e. only where needed) by means of innovative equipment or robots. SSWM strategies and tools can also be applied to non-chemical – mechanical or thermal – weed control. As such, SSWM seems well in line to meet the challenges brought about by the Directive, which can be synthesised in the following sentence: achieving a significant reduction in risks and use of pesticides while maintaining an adequate level of crop protection.

After having illustrated the main objectives of the Directive and the related actions, this paper will highlight the opportunities and limitations of SSWM in meeting the Directive objectives in the light of the presently available scientific knowledge, and discuss which of the key elements of Integrated Pest Management (IPM) adoption pointed out by the Directive can be taken up by SSWM.

## **THE EU FRAMEWORK DIRECTIVE ON SUSTAINABLE PESTICIDE USE**

The Directive was released on 21 October 2009 to fill the EU legislative gap regarding the use phase of pesticides. The key issues of the Directive are summarised in Table 1. Among them, three are particularly

noteworthy. First, all EU Member States must design a National Action Plan by 14 December 2012, indicating how they intend to reach the various objectives set forth by the Directive. Second, all professional users must be trained and must hold a certificate to be able to sell or use pesticides. Third, all Member States must ensure that all farmers use IPM principles and techniques from 1 January 2014.

Table 1. Key issues of the Directive and their goals.

Issue	Where (in the Directive)	Goals
National Action Plan	Art. 4	<ul style="list-style-type: none"> <li>- To indicate quantitative objectives, targets, measures and timetables to reduce risks and impacts of pesticide use on human health and the environment.</li> <li>- To encourage the development and introduction of IPM and of alternative approaches or techniques to reduce dependency on pesticide use.</li> <li>- To develop indicators to monitor the use of plant protection products with active substances of particular concern.</li> </ul>
Training, sales of pesticides, information and awareness-raising	Art. 5, 6 & 7	<ul style="list-style-type: none"> <li>- All professional users, distributors and advisors must have access to appropriate training by bodies designated by the competent authorities.</li> <li>- Distributors must hold a specific certificate to be allowed to sell pesticides.</li> <li>- Member States are responsible for delivering information regarding pesticide risks and safe use.</li> </ul>
Pesticide application equipment	Art. 8	<ul style="list-style-type: none"> <li>- Equipment must be inspected at regular intervals.</li> </ul>
Specific uses and indications	Art. 9, 11 & 12	<ul style="list-style-type: none"> <li>- Prohibition of aerial spraying.</li> <li>- Protection of aquatic environment and drinking water supplies.</li> <li>- Reduction or prohibition of pesticide use in specific areas (e.g. playgrounds, protected areas).</li> </ul>
Risk indicators	Art. 15	<ul style="list-style-type: none"> <li>- Establishment of harmonised risk indicators.</li> <li>- Identification of priority issues and best practices.</li> </ul>
Training subjects	Annex I	<ul style="list-style-type: none"> <li>- Prioritise subjects for training of all professional users</li> </ul>
Health, safety and environmental requirements related to the inspection of pesticide application equipment	Annex II	<ul style="list-style-type: none"> <li>- Identify machinery parts needing particular attention during inspections.</li> </ul>
General principles of IPM	Annex III	<ul style="list-style-type: none"> <li>- Provide indications to Member States on how to implement IPM</li> </ul>



## **SITE-SPECIFIC WEED MANAGEMENT: OPPORTUNITIES AND LIMITATIONS**

Site-specific weed management has attracted interest from agricultural researchers, practitioners and companies since the mid 1990s. Since then, concepts and technologies for SSWM have largely improved, but large-scale application is yet to come, despite a clear potential to reduce herbicide use and thus meet the Directive objectives.

SSWM is a four-step procedure including: (a) weed monitoring and mapping; (b) decision-making; (c) precision field operation, and (d) evaluation of results (López-Granados, 2011). Weed monitoring and mapping can be done by remote or proximal sensing, with various options depending on the objective and resources available (Table 2). At the moment, the main limitations of weed monitoring and mapping tools are: (a) their ability to identify weeds at species level, which would be required for optimised spraying, especially at an early crop stage; (b) their high cost; (c) the lack of adequately trained farmers/technicians. Some technological innovations, e.g. the refinement of object-based classification for remote sensing equipment, aimed to substitute pixel-based classification, show promising perspectives (Castillejo-González *et al.*, 2009) and might help refine weed identification. Technological advancement, e.g. in sensors and robots, should reduce machinery and consequently application costs in the foreseeable future. Lastly, the Directive (Art. 5) has the potential to set the ground for specific training on SSWM concepts and tools to end users.

Table 2. Tools available for weed monitoring and mapping in site-specific weed management.

Tool category	Examples
Remote sensing	Airborne, satellite and unmanned platforms.
Proximal sensing	In-field machine-mounted sensors (on combines, tractors or robots).
Real-time monitoring	Simultaneous weed detection and control (e.g. spraying).

## **DOES SITE-SPECIFIC WEED MANAGEMENT COMPLY WITH THE AIMS OF THE DIRECTIVE?**

The best way to address this question is to refer to Annex III of the Directive, which includes the eight principles of IPM that EU Member States are asked to put in place in all cropping systems from 1 January 2014. The concepts and tools of site-specific weed management are already well in line with three out of eight IPM principles and could match four of the remaining five should improved monitoring and application technologies

for SSWM be available in the future (Table 3). The only principle that is not met is No. 1 (prevention of harmful organisms), since to date SSWM addresses only direct (in crop) weed control.

Table 3. Relevance of site-specific weed management to the eight principles of IPM, as to Annex III of the Directive.

Principle No.	Content	Examples	Relevance of SSWM		
			Yes	Possible	No
1	Prevention of harmful organisms	Crop rotation, stale seedbed technique, balanced fertilisation			X
2	Monitoring of harmful organisms		X		
3	Application of control thresholds			X	
4	Preference to non-chemical methods	Biological, mechanical and thermal methods		X	
5	Use of selective pesticides	Use of pesticides with least side effects on human health, non-target organisms and the environment		X	
6	Reduction of pesticide doses	Reduced application frequencies, partial applications	X		
7	Application of anti-resistance strategies	Use of multiple pesticides with different mode of actions		X	
8	Check effect of applied measures	Records on pesticide use and monitoring of effect on harmful organisms	X		

Overall, SSWM seems well suited to fit into future European IPM systems. However, its use will likely be limited to major cropland where commodities are grown, at least until considerable reduction in equipment





and systems cost and development of more user-friendly solutions occur. One point of the Directive that would require some lobbying from the interested stakeholders is the inclusion of SSWM among the priority themes for training of professionals (farmers, technicians, etc.), because to date it is not explicitly mentioned in Annex I of the Directive.

## References

- Castillejo-González I. L., F. López-Granados, A. García-Ferrer, J. M. Peña-Barragán, M. Jurado-Expósito, M. Sánchez de la Orden and M. González-Audicana (2009) Object and pixel-based classification for mapping crops and their agri-environmental associated measures in Quick Bird imagery. *Computers and Electronics in Agriculture*, 68, 207-215.
- López-Granados F. (2011). Weed detection for site-specific weed management: mapping and real-time approaches. *Weed Research*, 51, 1-11.

**Topic 1.1:**  
Automated machines for chemical  
weed control





**TOPIC n° 1.1**

**Design, development and lab evaluation of a weed  
control sprayer to be used in robotic systems**

**Jacob Carballido<sup>1</sup>, Manuel Perez-Ruiz<sup>2</sup>, Chris  
Gliever<sup>3</sup>, Juan Agüera<sup>4</sup>**

<sup>1</sup>*Soluciones Agrícolas de Precisión, S.L. Campus de Rabanales. Edif. Leonardo da Vinci. 14014 Córdoba, Spain). (e-mail: [jacob@agrosap.es](mailto:jacob@agrosap.es))*

<sup>2</sup>*Dpto. Ingeniería Aeroespacial y Mecánica de Fluidos. Universidad de Sevilla. Ctra. Sevilla-Utrera km 1. 41.013 Sevilla, Spain (e-mail: [manuelperez@us.es](mailto:manuelperez@us.es))*

<sup>3</sup>*Dept. Biological and Agricultural Engineering, University of California-Davis, 1 Shields Ave, Davis CA, USA (e-mail: [gliever@ece.ucdavis.edu](mailto:gliever@ece.ucdavis.edu))*

<sup>4</sup>*Dpto. Ingeniería Rural. Universidad de Córdoba. Campus de Rabanales. Edif. Leonardo da Vinci. 14014 Córdoba, Spain). (e-mail: [jaguera@uco.es](mailto:jaguera@uco.es))*

**Keywords:** automation, site-specific weed control, direct injection system, sprayer

---

**Abstract:** Agriculture systems require safe, effective and efficient weed control operations to ensure the success of crop production. Increasing cost of pesticides and fertilizers has motivated operators to reduce application rates and manufacturers to develop spray equipment designed to improve application precision. The objective of this study was to design, develop and assess an innovative agricultural implement to be eventually integrated within a robotic system. In this work three scenarios were studied; low volume application (100 L/ha), standard volume application (200 L/ha) and high volume application (400 L/ha). The system provides a variable rate applications based on weed infestation maps. However, it is crucial to know the limitations of the hydraulic system. For the standard volume application the distance between the injection point and nozzle caused a time delay of 10 s. This result shows a



significant improvement compared to the study developed by Walker and Bansal 1999 with a time delay greater than 20 s.

---

## **1. Introduction**

Europe and EUR spent 8 billion on agrochemical in 2010 (ECPA, 2011). Increasing cost of pesticides and fertilizers induces operators to reduce application rates. This has motivated manufacturers to develop spray equipment designed to improve application precision. In particular, at two international workshops<sup>1</sup>, stakeholders highlighted the importance of sensors, decision support systems, and site-specific variable rate applicators in future crop operations. Agricultural systems require safe, effective and efficient weed control operations to ensure the success of crop production since pesticides and nutrients are required for efficient agricultural and forest crops production (e.g. annual crop, forestry, orchards, etc.). Uniform broadcast application is commonly employed in crop production despite its inefficiencies. Remote (satellite, aerial imagery) and proximal sensed data (soil, weed, crop parameter) can be georeferenced (Bareth and Doluschitz, 2010) enabling improved efficiency since weeds are typically unequally distributed over the field (Marshall, 1988; Gerhards and Oebel, 2006).

Currently, manufactures and innovative farmers have been building and retrofitting agricultural sprayers to incorporate Automatic Section Control (ASC) technology. This technology reduces chemical usage for many agricultural applications. An ASC system opens or closes boom sections or nozzle solenoid valves as needed. Valves close when a zone that has already been sprayed or for no-spray areas within a crop field. In this regards, Troesch et al., (2010) reduced over-application of pesticides and fertilizers by 1-12% per pass across field, in addition to the protection of the environment by not applying agricultural chemicals to non-target areas. The application of ASC technology in Alabama (USA) growers possibly results in 15,2-17,5% saving in sprayed zones by way of efficiently managing boom sections (Luck et al., 2010).

Variable Rate Application (VRA) reduces herbicide application in weed-free area within the field and increase fertilizer application on the low productivity sites. Both ASC and VRA require specialized instrumentation to sense soil, crop and weed plant locations. However these locations may be predetermined and combined within a map (called “prescription maps”) by means of a global positioning coordinates provided by a Global Navigation Satellite System receiver, often referred to as GNSS receiver.

The maximum potential of precision agriculture technologies can only be reached when the conventional farming increases its efficiency using a sufficient amount of data and adequate sensors (Mowitz, 2003; Rovira-Más et al., 2010). The objective of this study was to design, develop and assess an innovative agricultural implement to be eventually integrated within a robotic system. This system targets site-specific management of weed control using sensors and instrumentation that allow Automatic Section Control (ASC), Variable Rate Application (VRA), and Direct Injection Sprayer (DIS).

## **2. Materials and methods**

### ***2.1 Design of Prototype***

Twelve high-speed solenoid valves (Model VC01, NTech Industries, Inc. CA, USA) were mounted on a stainless steel sprayer boom with an equidistant spacing of 0.5 m. These solenoid valves consists of a ¼” barb brass inlet for incoming liquid, a spray nozzle, a nozzle cap, an LED indicator, a 3-pin electrical connector (signal, negative and positive), and two captive screws. The boom sprayer was divided into twelve sections, each containing one-solenoid valve. Each one of these valves was powered by a 12 V source that allows the spray from each section to be controlled independently. A LED indicator is lit when the solenoid is open.



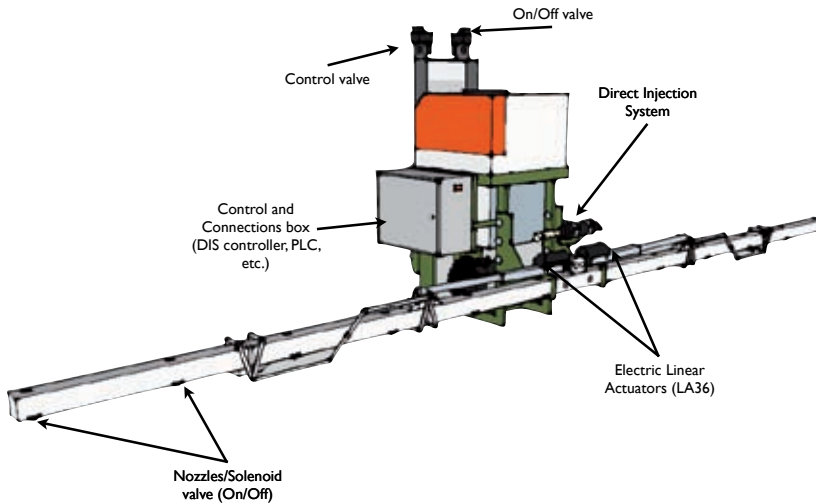

Fig. 1. Prototype weed control system built for initial tests

A commercial central direct injection system (Model Sidekick Pro, Raven Industries Inc., Sioux Falls, SD, USA) was equipped with a water tank (200 L) and a separate container for the herbicide (15 L) to be injected according to the prescription information from the High Level Decision System (HLDS). An intermediate connexion box between the sprayer and HLDS was created and installed to accommodate the signal sensors, hosting the injection system controller and the automation (PLC) device.

## 2.2 Laboratory Evaluation

Using a DIS in an agricultural sprayer is essential to enable the desired distribution of the agrochemicals between the injection point and nozzles as quickly as possible. A static mixer, the 4 cm diameter RAVEN mixer (Raven Industries, South Dakota, USA) was mounted downstream of herbicide injection point. These types of mixers have fixed mixing elements inside their pipe. A theoretical study of agrochemical particle path from injection into water flow to nozzle was conducted to determine the mechanical behaviour of the herbicide.

The liquid enters a pipe at one end, having cross section  $A_1$  and exit at the other end through cross section  $A_2$ . The velocity of

particles within the moving material will flow at different magnitudes along the length of the tube. The volume of moving medium passing a given plane in a time interval  $\Delta t$  is given by

$$\Lambda = \frac{V}{\Delta t} = \int \frac{\Delta x dA}{\Delta t} = \int v dA \quad (1)$$

where  $v$  is the velocity of moving medium which is integrated over area  $A$ , and  $\Delta x$  is the linear displacement of volume  $V$ . It is often convenient to define an average velocity

$$v_a = \frac{\int v dA}{A} \quad (2)$$

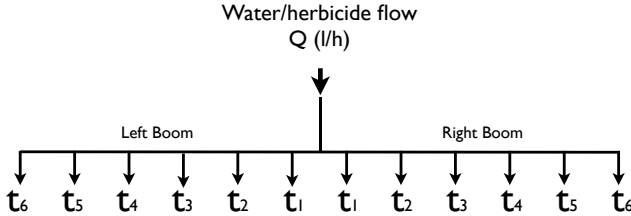

Fig. 2. Diagram of 12 solenoid valve/nozzles times

The solenoid valve/nozzles response time is the time from the start of the control pulse to the nozzle LED indicator's photon emission; this means the spray appears at the nozzle orifice (Miller & Watt, 1980). This time was theoretically calculated by using the flow speed (m/s) in each of the sections within the prototype spray system (Figure 2). Traditionally spraying has been done at 200 L/ha, but when used with broad-spectrum contact herbicides or high levels of penetration are required, a higher volume is recommended (between 400 L/ha and 1000 L/ha). In this work three scenarios were studied; low volume



application (100 L/ha), standard volume application (200 L/ha) and high volume application (400 L/ha). Field capacity, which refers to the area of land that a machine can accomplish per hour of time, can be expressed on a material or area basis.

### 3. Results and conclusions

An automatic sprayer, which controlled the HLDS through a GPS prescription map to determine its geospatial position and control the spray valves in the field, was successfully developed. Once all the components were assembled on the implement, the sprayer was tested in the workshop by simulating situations that would occur in field conditions. This system included mechanical (stability of the boom, hose length, etc.) and electrical (cables, voltage levels, power, communication equipment, etc.) subsystems. The reduction of DIS response time and increase of uniform processing requires knowledge of the system's functional parameters.

This provides a variable rate applications based on weed infestation maps. However, it is crucial to know the limitations of the hydraulic system. Therefore, the travel times from the injection point to the nozzles must be known. The data in Table 1 shows the times consumed for the flow in each scenario. For the standard volume application the distance between the injection point and nozzle caused a time delay of 10 s. This result shows a significant improvement compared to the study developed by Walker and Bansal 1999 with a time delay greater than 20 s.

Table 1. Theoretical travel time of water/herbicide flow in the sprayer system

Scenario	Applied flow rate (l/h)	Time before boom (s)	Right/Left Boom					
			t <sub>1</sub> (s)	t <sub>2</sub> (s)	t <sub>3</sub> (s)	t <sub>4</sub> (s)	t <sub>5</sub> (s)	t <sub>6</sub> (s)
1	275	4.53	1.32	3.16	3.95	5.26	7.90	15.79
2	550	2.26	0.66	1.58	1.97	2.63	3.95	7.90
3	1100	1.13	0.33	1.52	0.99	1.32	1.97	3.95

Lead-time to inject the herbicide before the spray according to the weed map were programmed into the controller (HLDS). This direct herbicide injection system kept the chemical and the water separate before actual spraying and thus the machine is easier to clean. One can also vary product rate application according to requirements.

#### **4. Acknowledgements**

*The research was funded by the RHEA European Project, included in the EU 7<sup>th</sup> Framework Programme under Grant Agreement No. 245986, and by Soluciones Agrícolas de Precision S.L. (SAP).*

#### **References**

- ASABE. (2011). *Agricultural Machinery Management Data*. ASABE Standards: ASABE D497.7MAR2011. ASABE, St. Joseph, MI 49085, USA.
- Bareth, G., Doluschitz, R. (2010). *Spatial data handling and management. Precision crop protection - the challenge and use of heterogeneity*. Springer, Heidelberg, pp. 205-232.
- ECPA 2011. European Crop Protection Association. [www.ecpa.eu](http://www.ecpa.eu).
- Gerhards, R. Oebel, H. (2006). *Practical experiences with a system for site specific weed control in arable crops using real-time image analysis and GPS-controlled patch spraying*. *Weed Research*, 46:185-193.
- Luck, J.D., Pitla, S.K., Shearer, S.A., Mueller, T.G., Dillon, C.R., Fulton, J.P., Higgins, S.F. (2010). *Potential for pesticide and nutrient savings via map-based automatic boom section control of spray nozzles*. *Comput. Electron. Agric.* 70, 19–26.
- Marshall, E.J.P. (1988). *Field-scale estimates of grass populations in arable land*. *Weed Research*, 28: 191-198.
- Miller, P. C. H., Watt, B. A. (1980). *The use of a high speed photographic technique to examine the response time characteristics of a solenoid spray valve*. *Journal of Agricultural Engineering Research*, 25, 217–220.
- Mowitz, D. (2003). *Precision begins at home: get machinery operating precisely before turning to precision agriculture (Business Perspective)*, *Successive Farming*, Feb. 2003, 101(2), 13.
- Rovira-Mas, F., Zhang, Q., Hansen, A.C. (2010). *Mechatronic and intelligent systems for off-road vehicles*. Springer, London, 2010.
- Troesch, A., D.K. Mullenix, J.P. Fulton, A.T. Winstead, S.H. Norwood, and A. Sharda. (2010). *Economic analysis of auto-swath control for Alabama crop production*. Conference Abstracts, 10th International Conference on Precision Agriculture, Denver, CO, July 18–21.





TOPIC n° 1.1

**Field robots for research and developments in site-specific  
weed management – Norwegian activities**

**Therese W. Berge<sup>1</sup>, Trygve Utstumo<sup>2,3</sup>, Jan Netland<sup>1</sup>**

<sup>1</sup>Norwegian Institute for Agricultural and Environmental Research (Bioforsk), Plant Health and Plant Protection Division, Høgskoleveien 7, 1432 Ås, Norway (e-mail: [therese.berge@bioforsk.no](mailto:therese.berge@bioforsk.no), [jan.netland@bioforsk.no](mailto:jan.netland@bioforsk.no))

<sup>2</sup>Adigo AS, Sætreskogveien 4, 1415 Oppegård, Norway (e-mail: [trygve@adigo.no](mailto:trygve@adigo.no))

<sup>3</sup>Norwegian University of Science and Technology (NTNU), Faculty of Information Technology, Mathematics and Electrical Engineering, Trondheim, Norway

**Keywords:** cereals, image analysis, machine vision, real-time, row crops, vegetables

---

**Abstract:** There is a growing interest in using robots for agricultural purposes, including weed control. Inter-disciplinary research projects with engineers and agronomists working in concert are necessary to develop adequate solutions for the end-users. Present paper summaries our talk presenting three Norwegian projects which include robot developments associated with site-specific weed management in cereals and field grown seeded vegetables.

---

## **1. Introduction**

There is a growing interest in using robots for agricultural purposes, including weed control. We will present three Norwegian projects involving robot developments relevant for site-specific weed management.

## **2. Projects involving agricultural field robots**

### ***2.1 Robot for research on machine-vision based patch spraying in small grain cereals***

The purpose of this 3-wheel, GPS-guided robot (Fig. 1) was two-fold: 1) effective collection of geo-referenced RGB images



as basis for development of machine vision algorithms and image-based weed mapping, and 2) testing real-time patch spraying (image acquisition, image analysis and spraying in the same field operation) of annual weeds in spring wheat and barley. The robot was developed by Adigo AS. The machine vision for automatic weed/cereal discrimination was developed by Adigo and SINTEF ICT (Oslo, Norway). The role of Bioforsk was to develop spray thresholds for post-emergence herbicides based on machine vision. See Berge et al. (2012) for more details and [www.bioforsk.no/weedcer](http://www.bioforsk.no/weedcer) for a video).



Fig. 1. GPS-guided robot used for R&D in machine-vision based site-specific weed management (SSWM) in small grain cereals. Left: Sampling of imagery for machine vision developments and map-based SSWM. Right: Robot conducting real-time SSWM with a 3-m wide spray boom (forward direction is to the right).

## 2.2 Robotic drop-on-demand for intra-row weeding

The goal of this robot is ultra precision spraying (“drop-on-demand”) of intra-row weeds in vegetables and row crops. To date, machine vision has been developed for seeded swedes (rutabagas, *Brassica napus* ssp. *rapifera*). A prototype shown in Fig. 2 demonstrated the concept in seeded rutabaga in 2010. This project has now been continued and machine vision algorithms for other crops (e.g. carrots) are in progress, together with research on navigation and droplet control. This is a joint

project between Adigo, NTNU and Bioforsk.

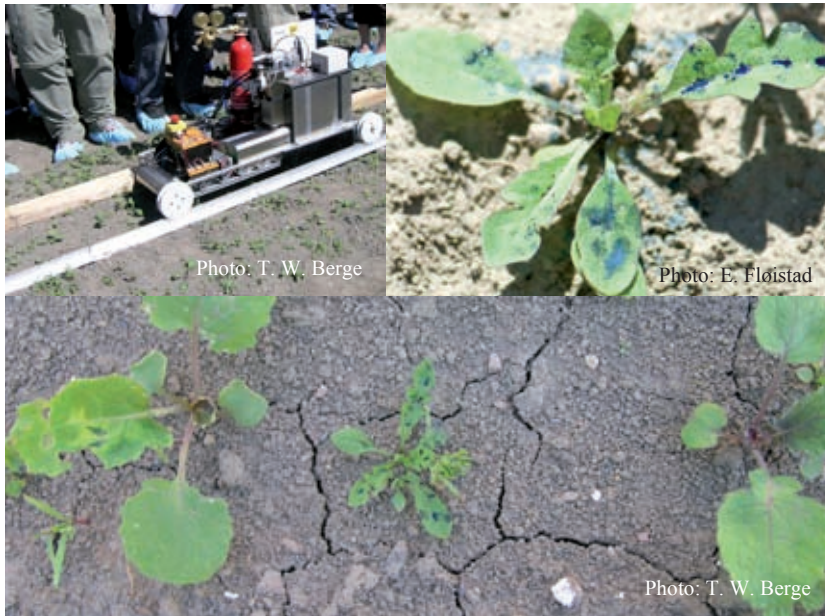

Fig. 2. Drop-on-demand intra-row weeding in seeded vegetables. Right: First prototype of robot (moving on rails) in the first field test in seeded rutabaga. Left: Close-up of a sprayed weed plant (and soil surface); blue food ink simulated herbicide. Bottom: Two unsprayed crop plants and one sprayed weed plant in one crop row.

### ***2.3 Robot for research on sustainable cereal production***

Automated, efficient and precise measurements strengthen any research effort. A specialized robot (Fig. 3) is in progress within the inter-disciplinary project “Multisensory Precision Agriculture – Improving yields and reducing environmental impact”. This robot has multiple purposes including image acquisition of perennial weeds in cereals for machine vision developments, and soil gas flux measurements ( $N_2O$  among others). This robot is constructed by Adigo, in collaboration with Bioforsk, SINTEF ICT (Oslo, Norway) and the Norwegian University of Life Sciences (Ås, Norway). The first prototype





Illustration: Adigo AS

Fig. 3. Robot used as a platform for research and developments in precision farming and greenhouse gas research. The robot has a variable track width of 1.80-2.20 m and an actuated lift boom for the two gas measurement chambers.

### 3. Conclusions

The robot used as a platform for research on site-specific weed management in cereals could successfully collect images for map-based site-specific weed management (SSWM), and demonstrate real-time SSWM at a speed of 1.8 km h<sup>-1</sup> (cf. Fig. 1; see [www.bioforsk.no/weedcer](http://www.bioforsk.no/weedcer) for a video). A robot aiming for drop-on-demand spraying of intra-row weeds in seeded vegetables is under development (cf. Fig. 2). A larger research robot for precision crop protection and spatio-temporal greenhouse gas fluxes will be tested in the field this year (cf. Fig. 3). Robots are valuable tools for researchers studying spatio-temporal phenomena at arable land. Robots will probably play an important role in sustainable, modern cropping.

### Acknowledgements

*The Norwegian Research Council and Norwegian rutabaga growers supported these projects. SINTEF ICT is acknowledged for their contribution on machine vision algorithms for annual weeds/cereal discrimination. Steve Goldberg is acknowledged for his excellent contribution on robotics and machine vision algorithms.*



## TOPIC N° 1.1

### **Hurdles to overcome in the development of spatially variable weed control (patch spraying)**

**Peter Lutman**

*Rothamsted Research, Harpenden, Hertfordshire, AL5 2JQ. UK  
(email [peter.lutman@btinternet.com](mailto:peter.lutman@btinternet.com))*

**Keywords:** weed management, herbicide, weed thresholds,  
herbicide application

---

**Abstract** A number of questions need to be answered before practical spatially variable weed control can be introduced. How do you decided ‘what is a patch’? If weed thresholds are used to define patch areas, is there sufficient information available on weed competition? Are buffers included around patches? Buffers will increase the treated area, reducing cost benefits but give added confidence to users. What treatment strategy is used? An on/off approach is simpler than a variable dose one and saves more herbicide. Is dose response data available to implement variable dose treatments? How small should treatment pixels be? The smaller the pixel the greater the sprayer costs but the greater the herbicide saving. Map accuracy may depend on the proportion of the field mapped. How much of the field needs to be surveyed? Answers to these questions are being developed but detailed economic analyses balancing costs and herbicide savings will be needed.

---

#### **1. Introduction**

Many weed species demonstrate aggregated distributions, so appreciable savings in herbicide use can be made by only treating weed patches. This is both financially attractive to the farmer and environmentally beneficial. How patchy are weeds? My own work has indicated that in S. England *Alopecurus*



*myosuroides* occurs on average in only 41% of the field area, (range 4-85% in 24 fields) (Lutman & Miller, 2007). Other workers have also shown that appreciable reductions in herbicides are possible if patch treatment is used (Gerhards & Christensen, 2003; Wiles, 2009).

The technologies linked to precision farming are making rapid progress. GPS navigation systems and associated computer controlled machine guidance are becoming increasingly reliable and precise. The increased use of GPS systems has also been associated with the development of boom section controls on sprayers. Additionally, great strides are being made in overcoming the hurdle of automated weed detection and increasingly sophisticated camera systems are being tested. In my view real time detection and spraying is not yet fully feasible for field crops because of the processing time needed, but this problem will eventually be overcome. British farmers believe that the technology has to deliver real time systems (Lutman & Miller, 2007) but my view is that the key to farmer acceptance is primarily a reliable automated detection system and that real time treatment is of secondary importance.

Even though giant strides have been made to solve many of the engineering problems associated with the development of patch spraying there are still a number of 'hurdles' to overcome to create practical systems for 'average' farmers. In this paper I will endeavor to highlight some of them and, where I can offer guidance on solutions. Christensen *et al.* (2009) identified three key elements to a patch spraying system: a weed sensing system, a weed management model that will provide guidance on treatment and an appropriate tool to apply the treatments (e.g. sprayer or cultivator). This paper will focus to a major extent on weed management decisions.

## **2. Weed detection and treatment decisions**

When mapping weed infestations there may be a limit to the detection of the equipment used (low densities of weeds not detected). Alternatively, a decision may be made that weed presence below a specified threshold should be ignored. The first question to resolve is what degree of weed infestation

merits treatment, i.e. where to draw the boundaries of the patches. To some extent this depends on the information collected by the detector (e.g. weed green area, weed seedling numbers, weed inflorescence numbers). Ideally, as proposed by Gerhards & Christensen (2003) and Gerhards *et al.* (2012), some form of competition model needs to be used to decide on a ‘threshold’ for each species. Previous research has tried to identify weed thresholds but practical use has been very limited. Recent research reported by Berge *et al.* (2012) used relative weed cover as a basis for creating a spray decision threshold. It needs to be emphasised that any lack of confidence in thresholds is less critical in a patch treatment scenario, as the key infestations close to the thresholds where decisions could be wrong only affect a limited number of pixels and not the whole field. However, the fundamental issue remains – how to decide what to include/exclude from patch areas. Two other issues relate to this decision: use of buffers and the treatment strategy.

## **2.1 Buffers**

It can be argued that buffers should be established around weed patches to allow for minor variations in geo-location and to accommodate any variability in the speed of response of the sprayer. But buffers can also be used to mitigate any uncertainty in the extent of the patch and to add re-assurance to the user that weeds are not being ‘missed’. This may seem an appropriate tool to use but large buffers can cause a major increase in the treated area. This is exemplified in Fig. 1 where two fields with the same weed infestation but with differing distributions are given 6m buffers. The presence of buffers in Field 2 triples the proportion of the field treated compared to Field 1. So although addition of buffers can be helpful it reduces the financial benefits of patch treatment.

## **2.2 Treatment strategy**

There are two fundamental approaches to herbicide treatment of patches: on/off or variable rates (high doses on patches, low doses on non-patch areas). In the former the economic benefit is maximized but the risk of weed escapes is greater. In the latter,



the amount of herbicide used is greater and so the financial benefit is lower but the user has re-assurance that any weeds outside the patch areas will be at least suppressed. This approach needs fundamental information on the dose response of the target weed(s) to the chosen herbicide(s). Such information is not widely available, although advice systems such as the Danish Crop Protection OnLine do provide dose response data (CPO, 2012). This lack of dose response data is a critical limitation to the development of variable rate treatments. An alternative to changing doses is the use of different products and/or mixtures on the patch and non-patch areas, but this too has drawbacks.

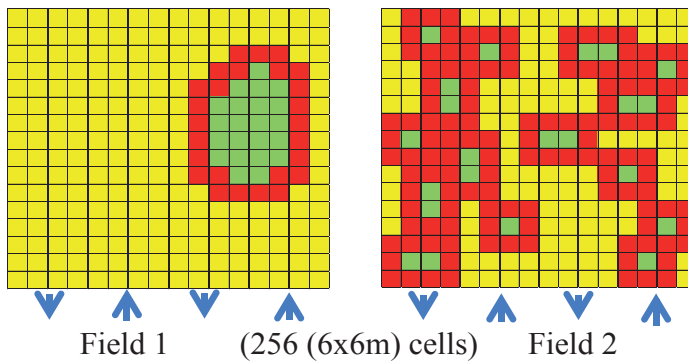

	Field 1	Field 2
No. of pixels treated without buffers	22 (8%)	22 (8%)
No. of pixels treated with buffers	48 (19%)	147 (57%)

Fig.1. Two schematic weed infestations (in green) and the impact of buffers (in red) on % of field requiring treatment:  
Field 1: a focused infestation: Field 2: a fragmented infestation

### 3. Patch characteristics and herbicide application

Figure 1 illustrates one of the key features of weed patch biology and of its consequences for treatment. Weeds can occur in a few big patches or in many small clusters. An optimal treatment system would divide the field up into many small units (pixels) and allocate treatments appropriately to each pixel. On a mathematical basis the smaller the pixel the better, as with small pixels the infested area that is treated is minimised.

Wallinga (1995) showed that for a given patchy infestation there is a log linear relationship between pixel size and perceived infested area. This can be illustrated in Fig 1 if the ‘fields’ are divided into different sized units according to the ability of the sprayer to respond to the treatment map. If a 24m sprayer without any boom section controls is compared to one with 4 x 6m sections, then the number of pixels requiring treatment declines from 52 to 22 in Field 1 and 72 to 22 in Field 2. Thus, a more highly engineered sprayer (with more costly controls) will provide the potential to lower the amount of herbicide used. Wallinga *et al.* (1998) also showed that increasing resolution from 4m to 2m lowered the amount of herbicide used to control *Galium aparine* by 26%. Of the field equipment tested, the Cerberus sprayer has 3m wide pixels (Gerhards & Oebel, 2006) and the prototype Norwegian sprayer has 3x3m pixels (Berge *et al.*, 2012). The basic message is ‘the smaller the pixel the better’, but this has to be balanced by the extra engineering costs. An estimate from a UK sprayer manufacturer was that boom section control combined with DGPS management would add £8000 (€9600) to the cost of *c.* £70,000 (€84,000) sprayer.

#### **4. Questions around field scanning to detect weeds - what percentage of the field should be surveyed?**

In the initial developments of spatially variable weed control, weed maps were created manually by human surveyors surveying the whole field. This is time consuming and expensive and was not attractive to potential users. Camera systems are now being developed that can automate weed detection. However, there is a drawback to many of the automated detection systems, as they do not scan the whole field and only collect discrete sets of information derived from strips or spots within the field and then use some form of mathematical analyses to interpolate the missing information. This leads to a key question – how reliable is the interpolation? This will depend on the percentage of the area actually scanned and the nature of the weed patches. Gerhards & Oebel (2006) reported that *c.* 3000 images ha<sup>-1</sup> 0.02m<sup>2</sup> were collected in their



patch mapping/treatment project. This means the cameras were actually monitoring less than 1% of the land area. In my view there remains a question to be answered as to how much of the field needs to be surveyed to create a map that adequately reflects the true distribution. Is it necessary to scan the whole field? Multiple cameras and associated computers would increase costs, impacting on the financial attractiveness of adoption of patch spraying.

## 5. Conclusions

This paper has highlighted some of the complexities that have to be addressed before weed distribution maps can be turned into useful spray treatments. Solutions to some of the issues raised are progressing well, but others remain to be fully resolved, before widespread adoption of patch spraying can be achieved. A detailed economic analysis to compare the reductions in herbicide costs achievable by different approaches, using real field infestations, and real costs of engineering controls required to achieve the desired spatial control, is needed.

## References

- Berge T.W., Goldberg S., Kaspersen K. and Netland J. (2012) Towards machine vision based site-specific weed control in cereals. *Computers and Electronics in Agric.*, 81, 79-86.
- Christensen S., Sogaard H.T., Kudsk P., Norremark M., Lund L., Nadimi E.S. and Jorgensen R. (2009) Site-specific weed control technologies. *Weed Res.*, 49, 233-241.
- Crop Protection On-Line (2012) Available at <http://pvvo.planteinfo.dk/cp/documents/InfoFactSheet.pdf?language=en> (accessed 2012)
- Gerhards R. and Christensen S. (2003) Real-time weed detection, decision making and patch spraying in maize, sugarbeet, winter wheat and winter barley. *Weed Res.*, 43, 385-392.
- Gerhards R., Gutjahr C., Weis M., Keller M. and Sokefeld M. (2012) Using precision farming technology to quantify yield effects attributed to weed competition and herbicide application. *Weed Res.*, 52, 6-15.
- Gerhards R. and Oebel H (2006) Practical experiences with a system for site-specific weed control in arable crops using real-time image analysis and GPS-controlled patch spraying. *Weed Res.*, 46, 185-193.
- Lutman P.J. W and Miller P.C.H. (2007) *A review of spatially variable herbicide application technology – opportunities for herbicide minimization and the protection of beneficial weeds.* Home-Grown Cereals Authority Research Review 62, pp 64. HGCA, Stoneleigh, England.
- Wallinga J. (1995) *A closer look at the spatial distribution of weeds – perspectives for patch spraying.* Proceedings 9<sup>th</sup> EWRS Symposium Budapest 1995, Challenges for Weed Science in a Changing World, 647-653.
- Wallinga J., Groeneveld R.M.W. and Lotz, L.A.P. (1998) Measures that describe weed spatial patterns at different levels of resolution and their application for patch spraying weeds. *Weed Res.*, 38, 351-359.
- Wiles L.J. (2009) Beyond patch spraying: site-specific weed management with several





TOPIC n° 1.1: Automated machines for chemical weed control

**Robotics for weed control: I-weed robot for a specific  
spraying**

**Christelle Gée.<sup>1</sup>, Eric Busvelle<sup>2</sup>, Ghislain Salis<sup>1</sup>, Sylvain  
Villette<sup>1</sup>, Jean-Noël Paoli<sup>1</sup> and Gawain Jones<sup>1</sup>**

<sup>1</sup> UMR 1347 'Agroécologie', AgroSup Dijon, Boulevard Docteur Petitjean, 21000  
Dijon (e-mail:c.gee@agrosupdijon.fr)

<sup>2</sup> UMR 6306 / Laboratoire Electronique, Informatique et Image - IUT Dijon-Auxerre,  
Route des Plaines de l'Yonne, 89000 Auxerre(e-mail:busvelle@u-bourgogne.fr)

**Keywords:** agricultural robot, guidance, RTK signal,  
herbicides, machine vision

**Abstract:** To preserve environment for a sustainable agriculture, we explore the development of a new autonomous robot, called I-Weed Robot (Intelligent Weed Robot), which aims at reducing herbicides in crop fields (maize, sunflower...). Using a high precision positioning signal (RTK) to locate the robot in the field, a Kaman filter and a proportional-integral-derivative controller (PID controller) allow adjusting the orientation of the robot depending on a predefined trajectory. As for the spraying system, a camera in front of the mobile platform detects weed plants thanks to an image processing based on a crop/weed discrimination algorithm (Hough Transform). At the back a spray boom triggers the right nozzle at the right time depending on the location of weeds. This article assesses the performance of the guidance and weed detection algorithms using numerical simulations (virtual trajectory, virtual field image). The robustness of the guidance algorithm is tested for different noisy signals (GPS, DGPS and RTK). The accuracy of the crop/weed discrimination algorithm is evaluated using a large data base of synthetic images generated by the 'SimAField' software. To evaluate the accuracy of the algorithm and understand the sources of misclassification errors, the results are summarized in a confusion matrix which indicates the number of correctly and





incorrectly classified pixels (both weed and crop classes). Results indicate accuracy up to 90%. A significant number of weed pixels are always considered as crops so that crop detection is overestimated. The reason is that the bandwidth value of the crop row mask that is automatically generated overlaps weed plant close to the crop row. These simulations demonstrate that both algorithms are reliable. However, further research in field conditions is necessary to confirm the promising results.

## **1. Introduction**

The popularity of autonomous mobile robots (i.e., Lely Juno, milking robots) is increasing in agriculture, especially in livestock farming, to improve animal welfare and simplify the drudgery of farmers work for a better lifestyle. At present the challenge is to move these mobile platforms from confined spaces (barns, stables...) to outside, to perform site-specific precision tasks in the field. As an example, Lely (<http://www.lely.com/>) designed the Voyager robotic fencer for automated grazing control of dairy cows.

A few commercial systems have been developed to reduce herbicide inputs. They are based on optical sensors and involve an automatic switch off of sections or nozzles on spray boom (i.e., the WeedSeeker system of Avidorhightech) but they are embedded on tractors or sprayers. The objective of the present work is to develop a mobile platform, I-Weed robot, dedicated to a localized herbicide spray. The robot is accurately guided in the crop field with a GPS RTK system whereas plant detection is performed by image processing using a machine vision system.

## **2. Materials and methods**

Experimental design: a homemade robot platform based on a small electric quad is carried out for this study. The dimensions are approximately 75cm in width and 80cm in length. with an electric motor driving the back wheels. The loaded charge of the robot is about 75 kg with a spraying tank of 25 liters. The maximum speed of the robot is about 10 km/h. The I-Weed

robot is dedicated to periodic crops such as maize, sunflower, sugar beet...

Guidance and navigation: the ARDUINO environment (an open-source electronic prototyping platform allowing creating interactive electronic objects) is implemented in a laptop:

- to control the speed and the power of the electric motor of the quad

- to recover the NMEA GPS frame information. A GPS receiver (Trimble AgGPS262) declares +/- 2cm accuracy with 3 possibilities of the signal rates (1Hz, 5Hz or 10hz). The RTK signal, a corrected GPS signal, is delivered by S@t-info company.

- to transform WGS84 (3D) coordinates into local coordinates (2D)

A recursive Kalman filter (Kalman, 1960) is implemented to optimize the noisy GPS signal. The Kalman equations are classical, they can be found for instance in (Boizot and Busvelle, 2007) with some other examples of real-time implementation. A predefined trajectory is first stored in a SD-card, then a robust and fast control law guides the robot between the rows till the end of the row (Ortiz and Olivares, 2006; Cariou et al., 2009; Lenain, 2010). Thus, a proportional-integral-derivative controller (PID controller) adjusts the orientation of the robot according to its real position and the knowledge of the predefined path. We choose a PID controller just because it is sufficient for our purpose, which consists basically in following a linear trajectory at constant speed. But since we want a very good precision, we used an accurate estimation of actual position, given by a Kalman observer. These algorithms consequently allow predicting the best position of the robot as a compromise between the predefined and actual positions. Then the direction of the robot is automatically determined by positioning an actuator controlled by the ARDUINO (steering cylinder) depending of the predicted position.

Machine vision and sprayer: a camera, with a yaw-angle of 45°, is fixed in front of the robot. Considering that the crop inter-row is 75 cm, this distance is the minimum length detected by the



camera. According the intrinsic parameters of the vision system and applying the pinhole model (Faugeras, 1993) we determine the height (H) of the camera and the field of view of the optical system.

The camera is connected to a laptop and a crop/weed discrimination algorithm is used to detect the weed patches in real time. We use two optimized libraries: the Microsoft Visual C++ software with the OpenCV (Open Source Computer Vision) library for the image processing, and the Intel Integrated Performance Primitive (Intel IPP) library of functions for multimedia and data processing applications. Then the ARDUINO sends information to the two actuators (Electro-Pneumatic Valves) to control the opening of two nozzles fixed on the spray boom (80 cm length) placed at the back of the robot.

Image processing for weed detection: the image is first converted to a binary image by applying Otsu's thresholding method. Then the crop/weed discrimination is based on the detection of the crop line using a Hough Transform (Jones et al., 2009a,b). Theoretically, according the knowledge of initial parameters (type of crop, inter-row width...) and the extrinsic (height and angle) and intrinsic parameters (focal length, width and length of the CCD...) of the camera, it is possible to determine the number of crop rows and to define a mask of the crop rows in the image. By applying a logical function between the initial image and the mask, we can deduce an inter-row weed infestation map (Bossu et al., 2008).

Verification and validation tests: before we realize field experiments, different validation procedures are implemented using simulated data (in first approximation) in order to check the efficiency of the two algorithms (guidance and crop/weed discrimination). Because few real images with inter-row weeds were available, we have tested the crop/weed discrimination algorithm on a large synthetic data base containing 2000 simulated images generated by the Sim-A-Field<sup>1</sup> open source

---

<sup>1</sup><http://www.agrosupdijon.fr/recherche/unite-propre-gap/telechargements/simafield.html>

program developed by Jones et al. (2010). The accuracy of the image processing to detect the inter-row weeds can be estimated on these images where the initial Weed Infestation Rate (WIR) is perfectly controlled. Two WIR are tested: 10% and 30%. To understand these errors and to evaluate the accuracy of the method, the classification results are summarized in a confusion matrix which indicates the number of correctly and incorrectly classified pixels (both weed and crop classes).

### 3. Results and conclusions

In order to test the limits of the navigation algorithm (Kalman filter + PID controller), three signals (GPS, DGPS and RTK) with different noise levels are simulated depending on the guidance parameters of the mobile platform (speed of 5 km/h, 10 Hz as repetition rate of signal, 35° steering lock on either side, turning circle 3 m in diameter). As presented in Figure 1, the results of the simulations demonstrate the accuracy of the guidance system to follow a predicted trajectory whatever the noise on the positioning signal (3 m, 50 cm or 2 cm). Moreover, the successful operation of the robot in crop fields can be obtained reducing the speed of the I-Weed robot during the U-turn at the end of the row.

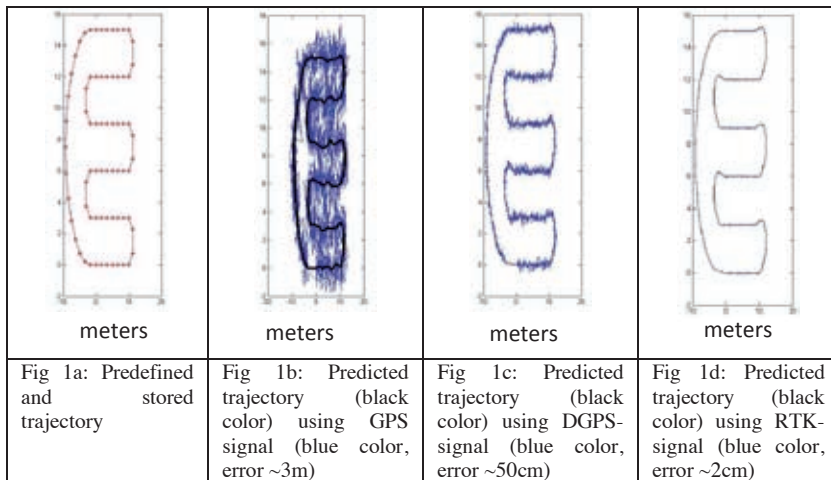

Concerning the comparison between the initial  $WIR_{inter-row}$  and the detected  $WIR_{inter-row}$  demonstrates that the classification method leads to misclassification errors. The crop/weed



discrimination algorithm based on the Hough transform gives accurate and robust results, up to 90% with a high computation time. One can note that there is a significant number of weed pixels that are always considered as crop pixels which implies that weed detection is underestimation. This is due to the over-estimation of the bandwidth value of the automatically generated mask. In conclusion, whatever the true WIR (10% or 30%), this algorithm seems to be also reliable in the presence of high weed infestation. These simulated experiments demonstrate the robustness of both algorithms, navigation and localized spray in crop fields. However, further research in field conditions is necessary to confirm the promising results.

## References

- Boizot N., Busvelle E. (2007). *Adaptive-Gain Observers and Applications in "Nonlinear Observers and Applications*, Gildas Besançon (Ed), LectureNotes in Control and Information Sciences, Vol. 363, Springer
- Bossu J., Gée Ch. and Truchetet F. (2008). *Development of a machine vision system for a real time precision sprayer*. Electronic Letters on Computer Vision and Image Analysis 7(3):54-66
- Cariou C., Lenain R., Thuilot B., and Berducat M. (2009). *Automatic guidance of a four-wheel-steering mobile robot for accurate field operations*. Journal of Field Robotics, vol. 26, pp. 504–518.
- Faugeras O. (1993) *Three-Dimensional Computer Vision*. MIT Press
- Jones G., Gée C., and Truchetet F. (2009). *Assessment of an inter-row weed infestation rate on simulated agronomic images*. Computers and Electronics in Agriculture. 67(1-2): p. 43-50.
- Jones G., Gée C., and Truchetet F. (2009). *Modelling agronomic images for weed detection and comparison of crop/weed discrimination algorithm performance*. Precision Agriculture. 10(1): p. 1-15.
- Jones G., Gee C., Villette S., Truchetet F. (2010). *Validation of a crop field modelling to simulate agronomic images*. Optics Express, 18(10) p. 10694-10703.
- Kalman R.E. (1960). *A new approach to linear filtering and Prediction problems*. Transaction of the ASME-Journal of basic engineering, 82:35-45
- Lenain R., Thuilot B.,Cariou C., Martinet P. (2010). *Mixed kinematic and dynamic sideslip angle observer for accurate control of fast off-road mobile robots*, Journal of field robotics, 27(2) p.181-196 DOI: 10.1002/rob.20319
- Ortiz J. M.; Olivares M. (2006). *A vision based navigation system for an agricultural field robot*. Conference: 3rd IEEE Latin American Robotics Symposium, Pages: 164-172





## Topic 1.2

### Automated machines for physical weed control







TOPIC n° 1.2

**A NEW PROTOTYPE TO PERFORM PRECISION  
TREATMENTS OF ACTIVATED STEAMING TO KILL  
WEED SEED BEFORE SOWING OF ORGANIC  
VEGETABLE**

**Andrea Peruzzi<sup>1</sup>, Christian Frascioni<sup>1</sup>, Luisa Martelloni<sup>2</sup>,  
Marco Fontanelli<sup>1</sup>, Michele Raffaelli<sup>1</sup>**

<sup>1</sup>*CIRAA "E. Avanzi", University of Pisa, Via Vecchia di Marina 6, 56122 S. Piero a  
Grado PI, Italy (e-mail: cfrascioni@agr.unipi.it)*

<sup>2</sup>*Dipartimento di Agronomia e Gestione dell'Agroecosistema, University of Pisa, via  
San Michele degli Scalzi, 2, 56124, Pisa (aperuzzi@agr.unipi.it)*

**Keywords:** Precision soil steaming, preventive and precision  
weed control in bands

---

**Abstract** Soil disinfection has been widely used for pest control  
in horticulture for the last few decades. Many active ingredients  
have been banned and researchers are now evaluating different  
alternative techniques as soil steaming.

The application of precision farming technologies can improve  
the efficiency of soil steaming, making the treatment "more  
targeted" to specific purposes, in example weed seedbank  
control.

Band steaming is a specific application of precision soil  
steaming which allows to reduce the intra-row weed seed-bank  
and lower labour-intense hand weeding treatments in organic  
farming.

A drawn machine has been built by the University of Pisa and  
has been testing in different sown vegetable crops in different  
Italian agricultural contexts.





## 1. Introduction

Soil disinfection was widely used for pest control in horticulture for decades. Recently, because of the increasing public concern about agrochemicals, many active ingredients for soil chemical fumigation have been banned by the European Union (Regulation EC No 1107/2009).

This action led the industry, the farmers and the researchers to a renew interest in soil steaming, as a residues-free technique for soil disinfection (Gay et al., 2001a and 2010b). Thus, new machines were developed by Research Institutions and private firm involved in agricultural machinery.

With this aim, innovative machines were developed by the University of Pisa in cooperation with Celli firm of Forli (Italy). These machines provide “activated” steam (steam plus exothermic compounds, like CaO) instead of pure steam, according to a specific patent of the Italian firm. This system is called “Bioflash system”. Researches, carried out within multidisciplinary collaborative projects in Italy, showed a significant effect of this system not only on nematodes and pathogens but also on weed seeds (Bàrberi et al., 2009; Peruzzi et al., 2011; Peruzzi et al., 2012).

Moreover, the application of precision farming technologies can improve the efficiency of soil steaming, making the treatment “more targeted” to specific purposes, in example weed seedbank control.

Weed competition is a major problem in organic agriculture, because the use of herbicides is prohibited. Vegetable crops are generally the most sensitive from this point of view, especially the sown ones, because they often need plenty of time for emergence. This often implies a large effort for hand weeding in the rows, which are very difficult to be treated physically in a selective way (Bàrberi, 2002, Van der Weide et al., 2008).

In this concern band steaming could be a promising “precision” application for preventive weed seeds control within the rows, for high-value organic/integrated crops (like vegetable crops).

## **2. MATERIALS AND METHODS**

The machines for soil steaming developed by the University of Pisa, in cooperation with Celli firm, provide “activated” steam, which means steam plus exothermic compounds – i.e. CaO – instead of pure steam (Bioflash system®). Researches, carried out within multidisciplinary collaborative projects in Italy, showed a significant effect of this system not only on nematodes and pathogens but also on weed seeds.

The effect of the bioflash system on weed seedbank was exploited to develop a new machine for “band-steaming”. In this case, steaming is performed just in strips (bands), where the crop will be successively “precisely” sown. Each strip corresponds to one crop row.

The machine is drawn and equipped with a water tank, a hopper containing the exothermic compound and an industrial steam generator providing an outflow of about 1300 kg h<sup>-1</sup>. The steam generator unit is connected to PTO-driven small rotary hoes 0.18 m wide placed on three foldable sections at a distance of about 0.35 m. Each section of the frame performs band steaming on four strips on three raised bed. Thus, the total working width of the machine may vary from 4.8 up to 5.3 m, according to the width of the tires of the tractor (0.20 – 0.40 m). Each unit is equipped with a carter which bears the steaming bar. The steam injection is superficial in order to kill the weed seeds till a depth of 5-7 cm (Fig.1).



Fig. 1. Operative machine for band-steaming at work

### **3. Results/Conclusions**

The first prototype of the machine has been already built. Specific on farm trials on carrot started at the end of 2011 in organic farms, spread throughout the Italian territory, and are still in progress.

As future perspective, this machine, once tested and optimized, could be implemented with innovative tools for precision agriculture, in order to allow a correct overlapping between the treated bands and the crop rows (Fig.2).



Fig. 2. Effects of steaming in crop row.

#### **Acknowledgements**

*The authors wish to thank the staff of MAMA-DAGA and CIRAA Enrico Avanzi for their contribution to this study and the Ministero delle Politiche Agricole Alimentari e Forestali for supporting this study.*



## References

- Regulation (EC) No 1107/2009 OF THE EUROPEAN PARLIAMENT AND OF THE COUNCIL of 21 October 2009, concerning the placing of plant protection products on the market and repealing Council Directives 79/117/EEC and 91/414/EEC.
- Bärberi, P. (2002) Weed management in organic agriculture: are we addressing the right issues?, *Weed Research*, 42, 176-193.
- Bärberi, P., Moonen, A.C., Peruzzi, A., Fontanelli, M., Raffaelli, M. (2009). Weed suppression by soil steaming in combination with activating compounds. *Weed Research*, 49, 55-66.
- Gay, P., Piccarolo, P., Ricauda Aimonino, D., & Tortia, C. (2010a). A high efficiency steam soil disinfection system. Part I: Physical background and steam supply optimization. *Biosystems Engineering*, 107, 74-85.
- Gay, P., Piccarolo, P., Ricauda Aimonino, D., & Tortia, C. (2010b). A high efficiency steam soil disinfection system. Part II: Design and testing. *Biosystems Engineering*, 107, 194-201.
- Peruzzi, A., Raffaelli, M., Ginanni, M., Fontanelli, M., Frasconi, C. (2011) An innovative self-propelled machine for soil disinfection using steam and chemicals in an exothermic reaction. *Biosystem Engineering*, 110, 434-442.
- Peruzzi, A., Raffaelli, M., Frasconi, C., Fontanelli, M., Bärberi, P. (2012). Influence of an injection system on the effect of activated soil steaming on Brassica juncea and the natural weed seedbank. *Weed Research*, 52, 140-152.
- Van der Weide, R.Y., Bleecker, P.O., Achten, V.T.J.M., Lotz, L.A.P., Fogelberg, F. & Melander, B. (2008) Innovation in mechanical weed control in crop rows, *Weed Research*, 48, 215-224.



**First RHEA International Conference on  
Robotics and associated High-technologies  
and Equipment for Agriculture**  
Hosted by the University of Pisa  
Pisa, Italy, September 19-20-21, 2012



**TOPIC n° 1.2**

**APPLICATION OF PRECISION FLAMING TO MAIZE  
AND GARLIC IN THE RHEA PROJECT**

**Andrea Peruzzi<sup>1</sup>, Christian Frascioni<sup>1</sup>, Luisa Martelloni<sup>2</sup>,  
Marco Fontanelli<sup>1</sup>, Michele Raffaelli<sup>1</sup>**

<sup>1</sup>*CIRAA "E. Avanzi", University of Pisa, Via Vecchia di Marina 6, 56122 S. Piero a  
Grado PI, Italy (e-mail: cfrascioni@agr.unipi.it)*

<sup>2</sup>*Dipartimento di Agronomia e Gestione dell'Agroecosistema, University of Pisa, via  
San Michele degli Scalzi, 2, 56124, Pisa (aperuzzi@agr.unipi.it)*

**Keywords:** Physical weed control, precision hoeing, precision  
flaming

---

**Abstract** Flame weeding is actually a well known and used physical treatment according to the increase in concerns about the effects of herbicides on human health and the environment and in the light of the new European laws. Flaming historically, was used at first as a pre-emergence treatment, both prior to planting and before crop emergence. Alternatively, flaming can be used also selectively after crop emergence or planting in tolerant species. Although inter-row weeds can be effectively controlled through mechanical cultivation, weeds that grow in the row are more difficult to control as, in some cases, cultivation is both ineffective and causes unacceptable levels of crop damage. This work aims to describe the specific machine for mechanical-thermal weed control which is being realized by the University of Pisa within the RHEA project. This machine is able to perform mechanical and thermal treatments at the same time in order to remove weeds mechanically from the inter-row space and perform in-row selective and precision flaming. The project is still on-going and the machine has not been fully realized and tested yet, thus no data is available at the moment.





## 1. Introduction

Flame weeding is actually a well known and used physical treatment according to the increase in concerns about the effects of herbicides on human health and the environment. Controlling weeds without the use of chemical herbicides can be problematic, and was cited as a crucial aspect involved in the transition from conventional to organic crop production (Walz, 1999). The aim of flaming is heating tissues of weeds rather than completely burning them (Leroux et al., 2001; Ulloa et al., 2011). The heat from the flame causes rupturing of the cell walls, which leads to water loss and plant death (Parish, 1990). An exposure time between 0,065 - 0,130 second at a temperature level of 800 - 900 °C in some cases could be sufficient to devitalize a weed (Thomas , 1964; Kang 2001). A large number of studies investigated the responsiveness of weeds to flaming. This factor seem to be related to the morphological characteristic of the plants, their development stage and to the amount of LPG (used to feed the burner) per unit surface (Ascard, 1995; Sivesind et al., 2009; Ulloa et al., 2010). Flaming historically, was used at first as a pre-emergence treatment, both prior to planting and before crop emergence. Alternatively, flaming can be used also selectively after crop emergence or planting in tolerant species (Sivesind et al., 2012). Although inter-row weeds can be effectively controlled through mechanical cultivation, weeds that grow in the row are more difficult to control as, in some cases, cultivation is both ineffective and causes unacceptable levels of crop damage (Melander and Rasmussen, 2001).

Moreover, the new European directives are firmly encouraging a sustainable use of pesticides as “the implementation of the principles of integrated pest management is obligatory... with priority given wherever possible to non-chemical methods of plant protection and pest and crop management (Directive 2009/128/EC)”.

This work aims to describe the specific machine for mechanical-thermal weed control which is being realized by the University of Pisa within the RHEA project. This machine is being designed in order to carry out physical treatments in maize and garlic, which are heat tolerant crops.

## **2. MATERIALS AND METHODS**

The European Project RHEA (Robot fleets for Highly Effective Agriculture and forestry management) aims to create a fleet of autonomous aerial and ground mobile units for general crop protection including the application of physical weed control in maize and garlic.

This machine is able to perform mechanical and thermal treatments at the same time in order to remove weeds mechanically from the inter-row space and perform in-row selective and precision flaming. The precision of the treatment will be enhanced by a guidance system associated with a row and a weed detection system. Mechanical treatments will be always realized, even without weed presence, as hoeing is very important from an agronomical point of view. On the contrary, flaming will be provided only if weeds have been detected in the row. Thermal treatment will be performed by means of a pair of burners per row. The pressure of the LPG, will be adjusted according to the weed cover: 0 Mpa if weed cover is equal to 0, 0.3 MPa and 0.4 MPa, according to a threshold of 25% of weed cover (Peruzzi et al., 2012).

The working width of the machine for mechanical and thermal treatments is 3 m. This covers four rows and three entire inter-row spaces of 0.75 m each and 2 half inter-row spaces of 0.375 m each. Each of the four units tills the soil between the rows using one goose-foot rigid central tine and two “L” shaped adjustable rigid side sweeps at a very shallow depth (0.03-0.05 m). Two burners per element are placed in order to hit one side of each crop row. The flame just hits the weeds growing in the “in-row” space and the lower, heat-tolerant part of the crop plants (Peruzzi et al., 2012).





a)

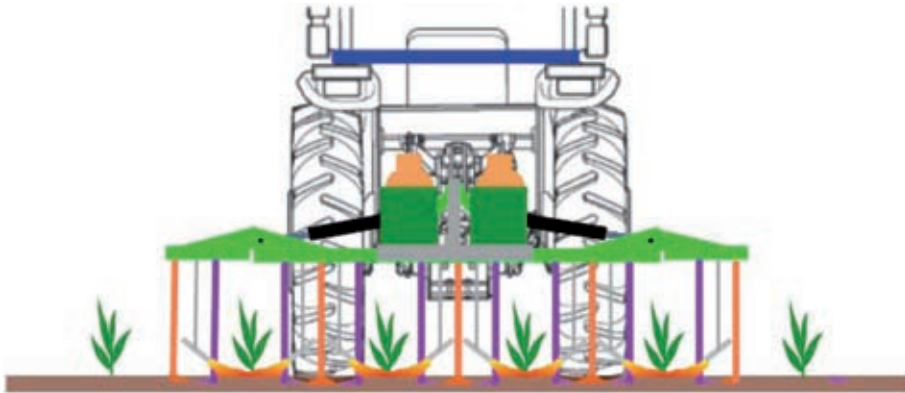

b)

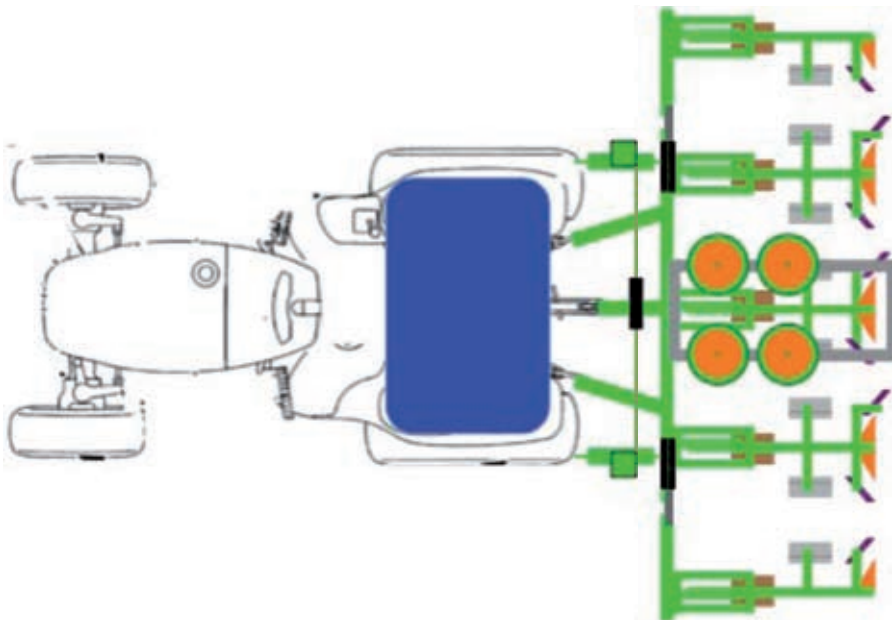

Fig. 1. Schemes of the machine for mechanical thermal weed control: side (a) and top (b) view.

### **3. Results/Conclusions**

This very innovative application of PWC in maize represents a good opportunity for farmers in terms of reducing the use of herbicides and ensuring that their crops are of a higher quality.



Fig. 2. Pictures of the very first prototype of the machine for precision weed control.



The project is still on-going and the machine has not been completed and tested yet, thus no data is available at the moment. However, a first integration of the operative machine with the RHEA GMU was performed in 2012 (Fig.2).

## Acknowledgements

*The authors wish to thank the staff of MAMA-DAGA and CIRAA Enrico Avanzi for their contribution to this study and the European 7<sup>th</sup> Framework Programme for supporting this study.*

## References

- Ascard, J., (1995). Effects of flame weeding on weed species at different developmental stages. *Weed Research*, 35, 397-411.
- Leroux, G.D., Douheret, J., Lanouette, M., (2001). Flame weeding in corn. In: Vincent, C., Panneton, B., Fleurat-Lessard, F. (Eds.), *Physical Control Methods in Plant Protection*. Springer-Verlag, Berlin, Germany, 47-60.
- Melander, B., Rasmussen, G., (2001). Effects of cultural methods and physical weed control on intrarow weed numbers, manual weeding and marketable yield in direct-sown leek and bulb onion. *Weed Research*, 41, 491-508
- Peruzzi A., Raffaelli M., Frascioni C., Martelloni L., Fontanelli M., Sarri D., Lisci R., Rimediotti M., Vieri M. (2012). An innovative autonomous ground mobile unit for the precision physical weed control, *Proceedings of International Conference of Agricultural Engineering CIGR-Ageng 2012*, Valencia Spain July 8-12 paper C1842.
- Sivesind, E.C., Leblanc, M.L., Cloutier, D.C., Seguin, P., Stewart, K.A., (2009). Weed response to flame weeding at different developmental stages. *Weed Technology*, 23, 438-443.
- Sivesind E.C., Leblanc M.L., Cloutier D.C., Seguin P., Stewart K.A., (2012). Impact of selective flame weeding on onion yield, pungency, flavonoid concentration, and weeds. *Crop Protection*, 39, 45-51.
- Ulloa, S.M., Datta, A., Knezevic, S.Z., 2010. Tolerance of selected weed species to broadcast flaming at different growth stages. *Crop Protection*, 29, 1381-1388.
- Ulloa S. M., Datta A., Bruening C., Neilson B., Miller J., Gogos G., Knezevic S.Z. (2011) Maize response to broadcast flaming at different growth stage: Effects on growth, yield, and yield components. *European journal of agronomy*, 34, 10-19
- Walz E. (1999) Final Results of the Third Biennial National Organic Farmers' Survey. Ed Organic Farming Research Foundation Santa Cruz CA USA, pp-130.
- Thomas, C.H. (1964). Technical Aspects of Flame Weeding in Louisiana. In *Proceedings of the First Annual Symposium of Research on Flame Weed Control*. Memphis, TN: Natural Gas Processors Association, 28-33
- Kang, W.S. (2001). Development of a Flame Weeder. *Transactions of the ASAE*, 44(5), 1065-1070.



**First RHEA International Conference on  
Robotics and associated High-technologies  
and Equipment for Agriculture**  
Hosted by the University of Pisa  
Pisa, Italy, September 19-20-21, 2012



TOPIC n° 1.2

Effect of flaming and cultivation on weed control and yield  
in maize and soybean

Avishek Datta<sup>1</sup>, Strahinja Stepanovic<sup>1</sup>, Brian Neilson<sup>2</sup>, Chris  
Bruening<sup>2</sup>, George Gogos<sup>2</sup>, Stevan Knezevic<sup>1</sup>

<sup>1</sup>*Haskell Agricultural Laboratory, University of Nebraska-Lincoln, Concord, NE  
68728, USA (e-mail: sknezevic2@unl.edu)*

<sup>2</sup>*Mechanical Engineering Department, University of Nebraska-Lincoln, Lincoln, NE  
68588, USA (ggogos1@unl.edu)*

**Keywords:** crop tolerance, organic crop production, non-  
chemical weed control, physical weed management

---

**Abstract:** Propane flaming in combination with cultivation could be a potential alternative tool for weed control in maize and soybean production. Field studies were conducted at the University of Nebraska, USA in 2010 and 2011 to determine the level of weed control and crop response to flaming and cultivation utilizing flaming equipment developed at the University of Nebraska. The treatments included: weed-free control, weedy season-long and different combinations of banded flaming (intra-row), broadcast flaming and mechanical cultivation (inter-row) applied at the V4 (4-leaf) and/or V6 (6-leaf) growth stages of maize, and at the VC (unfolded cotyledon) and/or V4 (fourth trifoliolate) growth stages of soybean. Propane rates were 20 and 45 kg ha<sup>-1</sup> for the banded and broadcast flaming treatments, respectively. The operating speed for all treatments was 5 km h<sup>-1</sup>. Weed control was evaluated visually at 28 days after treatment (DAT), and effects on grain yield. In maize, the combination treatment of mechanical cultivation and banded flaming applied at the V4 and V6 stages provided > 90% weed control and 10.9 t ha<sup>-1</sup> yield, which was similar to the weed-free control (11.3 t ha<sup>-1</sup>). In soybean, the highest yields were obtained in the weed-free control (3.1 t ha<sup>-1</sup>) and the plots flamed plus cultivated twice at the VC and V4 stages (2.8 t ha<sup>-1</sup>).



## 1. Introduction

Weeds are one of the major problems in both conventional and organic crop production systems and are responsible for significant crop yield reduction. However, controlling weeds in organic farming is challenging and requires the use of many techniques and strategies to achieve economically acceptable weed control and crop yields.

Mechanical cultivation is a widely-used method for removing weeds between crop rows (inter-row space). Although, the weeds that grow in the inter-row space can be effectively removed by cultivation, a strip of weeds remains within the crop row (intra-row). Thus, the weeds that grow close to the crop row present the greatest challenge in mechanical cultivation, as they directly influence crop performance. A combination of methods is therefore necessary to maintain satisfactory weed control in the entire crop row (both inter-row and intra-row space).

Propane flaming is one of the most promising alternatives for weed control in organic cropping systems (Ulloa et al., 2010; 2011). Flaming is a thermal weed control method that can kill weeds within or between crop rows using heat. Propane flaming is not an individual practice for non-chemical weed control. Other measures are still needed to control weeds that emerge later during the growing season. For example, many organic farmers in the USA typically utilize at least four to five weeding operations per season in their agronomic crops, which include a combination of multiple cultivation and/or hand weeding (Knezevic, personal observations). Therefore, the objective of this research was to determine the level of weed control and crop response to flaming and cultivation conducted up to two times per season. Reducing the number of weed control operations (e.g., trips across the field) can provide significant savings to the production costs of maize and soybean.

## 2. Materials and methods

Field experiments were conducted in 2010 and 2011 at the University of Nebraska, Concord, Nebraska, USA. The tested crops were maize and soybean, which were planted in rows spaced 76 cm apart with a four-row planter in 10 m × 3 m plots.

## *2.1 Experimental design and treatments*

The experiment was set up as a randomized complete block design with four replications. The treatments consisted of a weed-free control, a weedy season-long and six weed control treatments that included cultivation once (V4 for maize and VC for soybean), cultivation twice (V4 and V6 for maize, and VC and V4 for soybean), cultivation plus flaming once (V4 for maize and VC for soybean), cultivation plus flaming twice (V4 and V6 for maize, and VC and V4 for soybean), full flaming once (V4 for maize and VC for soybean) and full flaming twice (V4 and V6 for maize, and VC and V4 for soybean).

## *2.2 Flaming machines*

Flaming was conducted with the flame weeding equipment developed by the University of Nebraska and was driven at a constant speed of 5 km h<sup>-1</sup> with the ‘four-row full flamer (4-R FF)’ and the ‘four-row flamer/cultivator (4-R FC)’.

The 4-R FF had eight torches, which were shielded with hoods to keep the heat close to the ground and weeds, thus generating a sufficient amount of heat using less propane. The propane rate was 45 kg ha<sup>-1</sup>. In the early season setup, the hoods were closed to flame during the early vegetative growth stages of crops: V4 for maize and VC for soybean. In the late season setup, the hoods were opened to create a 10 to 15 cm gap between the two hoods, which allowed the crop row to pass through the gap.

The 4-R FC was designed by retrofitting flaming torches and hoods onto a Noble Four-Row-Runner cultivator. The hoods were 30 cm wide and were centred over the crop row. The propane rate was only 20 kg ha<sup>-1</sup>, as 30 cm intra-row space on either side of the crop row was flamed. The hoods were closed to flame at the early growth stages. During late-season flaming, the crop passed through a 10 cm opening (gap) between the two halves of the hood.

## *2.3 Data collection and statistical analysis*

Weed control was evaluated visually at 28 DAT utilizing a scale from 0 to 100% (0 = no weed control and 100 = complete weed



control). For grain harvest 6 m<sup>2</sup> areas of the centre two rows of each plot were hand clipped. Reported yields were adjusted to 15.5% moisture for maize and 13% moisture for soybean. An ANOVA was performed using PROC GLIMMIX procedure in SAS to test for significance ( $P < 0.05$ ) of years, treatments, replications and their interactions based on the response variables. The treatment means were separated by Fisher's Protected LSD procedure at  $P = 0.05$ .

### 3. Results and conclusions

#### *3.1 Effect of flaming and cultivation in maize*

Levels of weed control at 28 DAT varied from poor ( $< 50\%$ ) to excellent ( $> 90\%$ ) (Tab. 1). Maize cultivated once at the V4 stage provided only 33% weed control compared to the 92% control in the plots that received twice the combination of cultivation and banded flaming (V4 & V6 stages).

Maize cultivated once at the V4 stage had the lowest yield (8.2 t ha<sup>-1</sup>), while the plots cultivated twice yielded 8.4 t ha<sup>-1</sup>. The combination treatment of cultivation and banded flaming applied twice (V4 & V6 stages) yielded 10.9 t ha<sup>-1</sup>.

Full flaming conducted twice (V4 & V6 stages) also resulted in 83% weed control and 10.1 t ha<sup>-1</sup> yields, which were statistically similar to the weed control and yields obtained from the combination treatment of cultivation and banded flaming (Tab. 1). There was a regrowth of grassy weeds in the intra-row space after full flaming treatments, which is the reason for 83% weed control ratings. There was no regrowth of broadleaf weeds (data not presented).

#### *3.2 Effect of flaming and cultivation in soybean*

Levels of weed control in soybean at 28 DAT also varied among treatments, ranging from poor ( $< 50\%$ ) to satisfactory ( $> 80\%$ ) (Tab. 2). Soybean cultivated once at the VC stage had only 30% compared to the 83% control in the plots that received the combination of cultivation and banded flaming twice (VC & V4 stages). The combination of cultivation and banded flaming applied at the VC and V4 stages provided only 83% weed



control due to the regrowth of grassy species. There was no regrowth of broadleaf weeds (data not presented).

There was an initial injury of soybean (data not shown), but the crop recovered well after flaming, regardless of the treatment. Full flaming conducted once at the VC stage resulted in the lowest yield ( $1.5 \text{ t ha}^{-1}$ ) due to weed competition from subsequent weed flushes. The highest yields were obtained in the weed-free control ( $3.1 \text{ t ha}^{-1}$ ) and the plots flamed and cultivated twice at the VC and V4 stages ( $2.8 \text{ t ha}^{-1}$ ). Full flaming conducted twice at the VC and V4 stages yielded  $2.6 \text{ t ha}^{-1}$ .

In maize, the most promising weed control strategies were the combination of banded flaming with cultivation or full flaming, both conducted twice per season, which provided satisfactory weed control of 92% and 83%, respectively, and statistically similar yield to the weed-free control. From a practical standpoint, these results are encouraging and need to be verified further in a larger maize production setting. Reducing the number of weed control operations to only two per season can result in a significant savings in organic maize production.

In soybean, the most promising weed control strategy was the banded flaming plus cultivation conducted twice which provided satisfactory weed control of 83%. From a practical standpoint, an additional weed control operation in soybean might be needed to obtain close to 90% level of weed control.

In both maize and soybean, none of the treatments provided over 95% weed control, suggesting that there is a need for more than two weed control operations per season. Some may argue that such high level of weed control ( $> 95\%$ ) may not be necessary from both economic and environmental standpoint, and the fact that most organic growers are satisfied with about 80% weed control (Knezevic and Ulloa, 2007). In order to achieve such high levels of weed control ( $> 95\%$ ), an innovative combination of weed control tools and timings of their use are needed. Such strategies might be also highly depended on the field-specific characteristics and cropping history. Additional studies are needed to test such a hypothesis.





Table 1. Effect of different flaming and cultivation treatments on weed control (28 DAT) and yield in maize

Treatment	Weed Control (%)	Yield (t ha <sup>-1</sup> )
Weed-free control	-	11.3
Cultivation once (V4)	33	8.2
Cultivation twice (V4 & V6)	43	8.4
Cultivation + flaming once (V4)	27	8.7
Cultivation + flaming twice (V4 & V6)	92	10.9
Full flaming once (V4)	32	9.0
Full flaming twice (V4 & V6)	83	10.1
Weedy season-long	-	7.1
LSD (P = 0.05)	13	1.2

Table 2. Effect of different flaming and cultivation treatments on weed control (28 DAT) and yield in soybean

Treatment	Weed Control (%)	Yield (t ha <sup>-1</sup> )
Weed-free control	-	3.06
Cultivation once (VC)	30	1.67
Cultivation twice (VC & V4)	40	1.84
Cultivation + flaming once (VC)	36	1.96
Cultivation + flaming twice (VC & V4)	83	2.78
Full flaming once (VC)	16	1.50
Full flaming twice (VC & V4)	70	2.55
Weedy season-long	-	1.36
LSD (P = 0.05)	12	0.25

## Acknowledgements

*The authors wish to thank the Propane Education and Research Council for partial financial support of this project.*

## References

- Knezevic, S.Z. and S. M. Ulloa (2007). Flaming: potential new tool for weed control in organically grown agronomic crops. *Journal of Agricultural Sciences*, 52, 95–104.
- Ulloa, S. M., A. Datta and S. Z. Knezevic (2010). Tolerance of selected weed species to broadcast flaming at different growth stages. *Crop Protection*, 29, 1381–1388.
- Ulloa, S. M., A. Datta and S. Z. Knezevic (2011). Growth stage influenced sorghum response to broadcast flaming: Effects on yield and its components. *Agronomy Journal*, 103, 7–12.



**TOPIC n° 1.2**

**Sensor based LPG management system for application of  
precision flaming**

**Christian Frasconi<sup>1</sup>, Marco Fontanelli<sup>1</sup>, Michele Raffaelli<sup>1</sup>,  
Luisa Martelloni<sup>2</sup>, Andrea Peruzzi<sup>1</sup>**

<sup>1</sup>*CIRAA "E. Avanzi", University of Pisa, Via Vecchia di Marina 6, 56122 S. Piero a  
Grado PI, Italy (e-mail: cfrasconi@agr.unipi.it)*

<sup>2</sup>*Dipartimento di Agronomia e Gestione dell'Agroecosistema, University of Pisa, via  
San Michele degli Scalzi, 2, 56124, Pisa (aperuzzi@agr.unipi.it)*

**Keywords:** precision-flaming, hoeing, non-chemical weed  
control

---

**Abstract** Modern technologies allow to design and implementing autonomous robotic weed control system, suitable to perform treatments according to a precision farming management. The RHEA European project fits in this branch of research with the aim of project and provide a fleet of different autonomous robot units in order to perform precise and targeted treatments related to crops protection, allowing to lower agrochemical, energy and hand labour input. In this work is described the LPG feeding system of an autonomous robotic ground mobile unit designed to perform thermal and mechanical weed-control treatment on maize.

---

## **1. Introduction**

In the last decades, new technologies based on machines vision analysis, global positioning systems, decision-making capabilities for processing information entered strongly into the word of agriculture. Many researchers provided a lot of efforts in order to design and realize autonomous robots able to perform weed control (Slaughter et al., 2008). Many of these equipments can perform non-chemical weed control and they consist in precision weeders (provided with hoes or other similar



implements) with systems for weed detection and automatic row crop guidance (Slaughter et al., 2008). In this framework in 2010 started an European Project called RHEA “Robot Fleets for Highly Effective Agriculture and Forestry Management” aiming to realize different autonomous robot units in order to perform precise and targeted treatments related to crops protection. In this paper is described the LPG system management of an autonomous ground mobile unit able to perform mechanical and thermal weed control on maize. The first machines combining mechanical and thermal weed control was patented in 1900, and over time other prototypes were produced by researchers (Neilson, 2012; Peruzzi *et al.* 2007).

The operative machines for physical weed control, developed within the Rhea Project, has a modular structure. (Peruzzi *et al.*, 2012)

## **2. LPG management system**

The machine was designed to perform mechanical and targeted thermal weed control (Peruzzi *et al.*, 2012). Cross flaming in the row of the crop will be performed always at the same driving speed ( $6 \text{ kmh}^{-1}$ ) but with two different working pressures, according to the degree of weeds cover detected by a vision based perception systems mounted on the front part of the ground mobile unit. In this way we obtain two levels of “intensity” of thermal treatment (corresponding to two different LPG doses per unit surface). As a matter of fact, using higher operating pressure can improve the penetration of the flame in dense weed canopy (Thomas, 1964).

The values of the LPG working pressures are 0.3 MPa and 0.4 MPa, and they will be adopted according to the level of weeds infestation, as shown in table 1. Each flaming module is composed by two 25 cm wide rod burners fed by an LPG tank, and all the actuators and the sensor devices of the systems will be managed by a PLC mounted on the machines (Fig. 1).

TABLE 1: Different LPG working pressures values according with different levels of weed cover detected by the perception system

Weed cover (wc) thresholds (%)	LPG Working Pressure (MPa)
wc=0	0 (no treatment)
$0 < wc \leq 25$	0.3
wc>25	0.4

Following the LPG feeding line, after the bottle, there is a manual pressure regulator that will be set at the values of 0.5 MPa. A pressure transmitter (device that convert pressure in a low voltage out-put) will monitor the status of the LPG tank sending an analog signal to the PLC. When the LPG in the bottle is going to finish and the pressure decrease at values below 0.4 MPa, PLC will close the main electro-valves and transfers the information at the general control and management system of the ground mobile unit. All the electro-valves of the systems are normally closed solenoid valves enabling the LPG flux when they are supplied with electrical power input. After the main electro-valve the LPG feeding line is splitted in two branches, one for each working pressures (Fig. 1).

Each branch is provided upstream with a manual pressure regulator (set at the proper value of working pressure) and downstream with a secondary electro-valve. The PLC assisted by the information processed by the weed detection system will activate the proper secondary electro-valve according to the level of weed infestation (Table 1).

After the secondary electro-valve the gas feeding line is provided with an external LPG/air mixer that allows the access of primary air (Fig. 2), other inlet on the carter of the burners enable the intake of the secondary air.

Both primary and secondary air self-aspirating systems are based on the Venturi effect. In the first case (external LPG/primary air mixer) depression is created by the flow of



LPG at high speed achieved by a passage through a narrow nozzle section. The secondary air is aspirated by the depression created by the flow of the flame, thus it depends on its speed. Each burner is provided by an electric ignition system managed by the PLC.

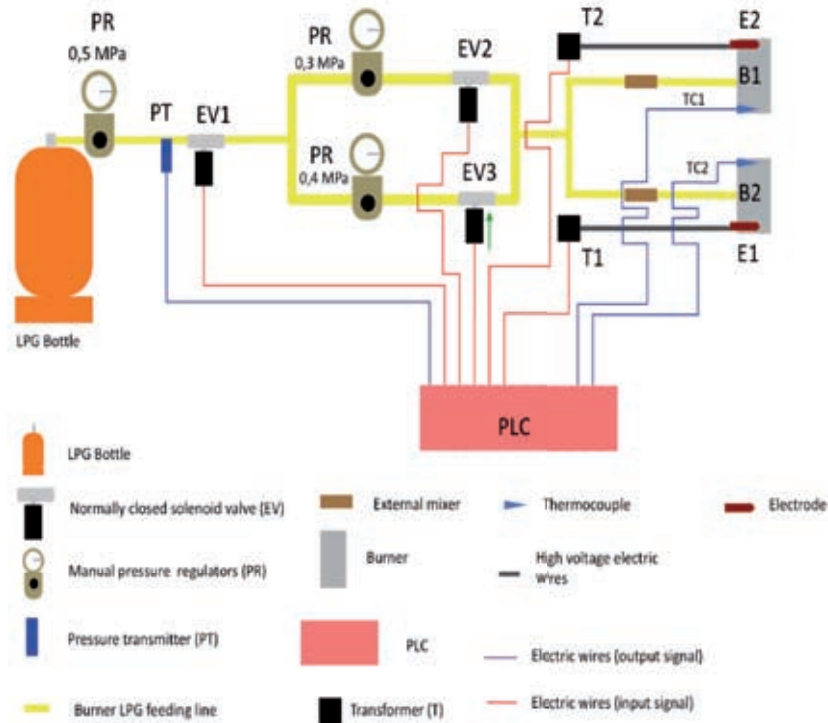

Fig. 1. Scheme of the LPG management system provided on the autonomous ground mobile unit: PR) manual pressure regulator; PT) pressure transmitter; EV1) normally closed solenoid main electro-valve; EV2-EV3) normally closed solenoid secondaries electro-valves; PR) pressure regulator; T) transformer; E) electrode; PLC) programmable logic controller.

The electric ignition system consists in a transformer, one for each burner, converting the voltage values of 24V-DC to 12kV-AC and a bipolar electrode with a ceramic insulator body.

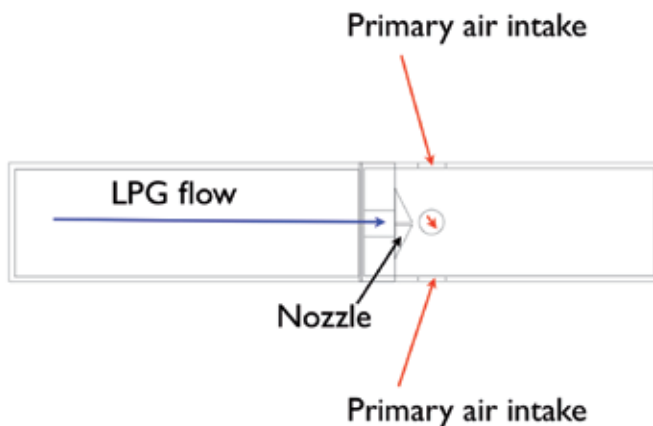

Fig. 2. Scheme of the LPG/Primary air external mixer.

The power of the transformer (80W) allows obtaining an electric arc between the two poles of the electrode, able to “instantly” ignite the LPG/air mixture even at the higher working pressures (Fig. 3).

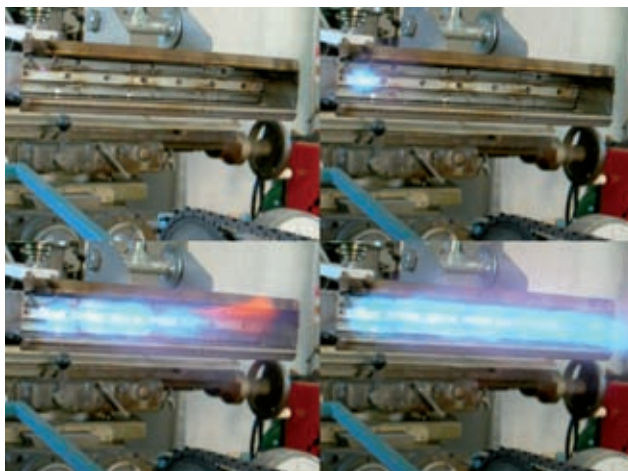

Fig. 3. Sequence of the electric ignition of the burner at the working pressures of 0.4 MPa.

So during the treatment, after the opening of the main electro-valve, the PLC will send a signal to open the adequate secondary electro-valve and contemporary will provide the



power supply for the transformers.

Each burner is also provided with a type K thermocouple, checking the presence of the flame during the treatment and sending a low voltage output signal to the PLC. In case of accidental shutdown of the flame, the PLC will close the main electro-valve avoiding LPG efflux.

### 3. Conclusions

The automatic, sensor based LPG feeding system projected and partially realized in order to be used for the proper functioning of the autonomous ground mobile unit for thermal and mechanical weed control represents the first application in the world of this kind. This system will allow the ground mobile unit to perform precision flaming with different degrees of intensity according to weed cover detected by the perception system. This robotic application will allow to apply flaming automatically, reducing LPG consumption per ha with respect to the amount commonly used with conventional “low-tech” flaming machines.

### Acknowledgements

*The authors wish to thank the staff of MAMA-DAGA and CIRAA Enrico Avanzi for their contribution to this study and the European 7<sup>TH</sup> Framework Programme for supporting this study*

### References

- Neilson, B.D. (2012). *The integration of propane flaming and mechanical cultivation for effective weed control in agriculture*, Thesis for degree of Master of Science, University of Nebraska Lincoln U.S.A, 1-13.
- Peruzzi A., Raffaelli M., Frascioni C., Martelloni L., Fontanelli M., Sarri D., Lisci R., Rimediotti M., Vieri M. (2012). An innovative autonomous ground mobile unit for the precision physical weed control, *Proceedings of International Conference of Agricultural Engineering CIGR-Ageng 2012*, Valencia Spain July 8-12 paper C1842.
- Peruzzi A., Ginanni M., Fontanelli M., Raffaelli M., Barberi P. (2007). Innovative strategies for on-farm weed management in organic carrot, *Renewable Agriculture and Food Systems*, vol. 1, pp 17-31, tot. pag 15
- Slaughter D.C., Giles D.K., Downey D., (2008) Autonomus robotic weed control systems: A review, *Computers and electronic in agriculture*, 61, 63-78.
- Thomas, C.H. (1964). Technical Aspects of Flame Weeding in Louisiana. In *Proceedings of the First Annual Symposium of Research on Flame Weed Control*. Memphis, TN: Natural Gas Processors Association, 28-33





## Topic 1.3

### Automated machines for tree crop protection

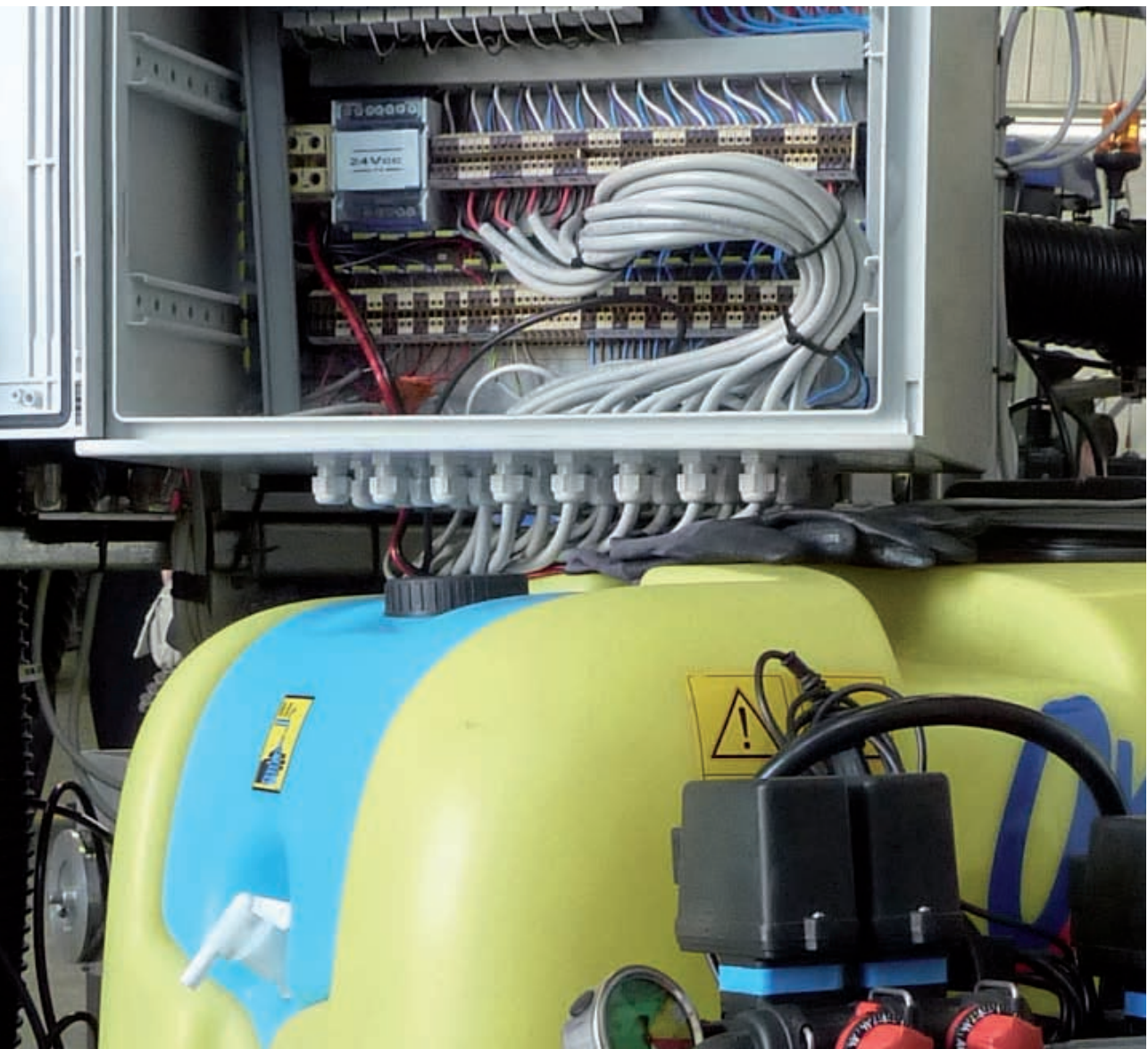



**Session 1:**  
Equipment innovation



TOPIC n° 1.3

## Canopy optimised sprayer development within CROPS EU project

**Hočevar, M.<sup>1</sup>, Godeša, T.<sup>1</sup>, Širok, B.<sup>1</sup>, Malneršič, A.<sup>1</sup>, Ježič<sup>2</sup>**

*1 University of Ljubljana, Faculty of Mechanical Engineering, Aškerčeva 6, SI 1000 Ljubljana, Slovenia, marko.hocevar@fs.uni-lj.si*

*2 Agricultural Institute of Slovenia, Hacquetova ulica 17, SI 1000 Ljubljana, Slovenia*

**Keywords:** canopy optimised spraying, sensing, manipulator

---

**Abstract:** To protect plants from diseases and pests chemicals are used. We present canopy optimised sprayer development under CROPS EU project, which should optimize the application of pesticides according to shape and density of plantation. Sensing equipment should detect the shape and density of a canopy. Main sensing devices are laser scanner, RGB camera and ultrasonic sensors. For the analysis of sensing data, the tree canopy is sliced in three sections from top to bottom. For each slice single end effector is adjusted in accordance with slice parameters and its spray requirements. The manipulation arm with spraying elements of the prototype sprayer system for canopy optimised spraying is mounted on a trailed air-assisted sprayer. Manipulator part of canopy optimised spraying is designed with eight degrees of freedom. The final goal of close range precision sprayer, developed within CROPS project is to achieve canopy optimized spraying with reduction of pesticide application by 30%.

---

### 1. Introduction

Apple fruit orchards are sprayed mainly with ‘mistblower’ orchard sprayers. Unfortunately, the large radial spray plume generated is prone to spray drift, thus large losses to the atmosphere and ground occur (Cross et al., 2001). A number of systems for adjusting the applied dose of plant protection products according to orchard structure have been developed in



the past decades. One widely accepted is the Tree Row Volume (TRV) dosing system initiated by Byers et al., 1971. In this system, the dose applied to an orchard is selected by varying the spray volume at constant pesticide concentration in proportion to the TRV. In contrast to the TRV model, Pergher et al., 1997 and Pergher and Petris, 2007 proposed the use of leaf area measurements to improve the correlation between deposits given by different types of spraying equipment and types of hedgerow vineyards. Different shapes and sizes of tree canopies require continual calculation of TRV to optimize the spray application efficiency (Solanelles et al., 2006).

In the last 10 years measurement of crop structure has been simplified by the development of a range of non-invasive optical and ultrasonic sampling techniques. The development of a range detection system (LIDAR) has made it possible to take quick and detailed readings of crop structure (Wangler et al. 1997). These are suitable for computational processing to calculate a wide range of summary parameters based on a probabilistic interpretation of light transmission and crop interception characteristics (Walklate et al., 2002).

We suggest such a modified system of actuators that volume, direction and position of spray outlet could be fine adjusted in dependence of the tree row canopy shape and density. The proposed canopy optimised sprayer is built under CROPS 7FP EU project.

Crops is a large-scale integrating FP7 EU project in the theme Nanotechnologies, Materials and new Production Technologies. CROPS is aimed to develop scientific know-how for a highly configurable, modular and clever carrier platform that includes modular parallel manipulators and intelligent tools (sensors, algorithms, sprayers, grippers) that can be easily installed onto the carrier and are capable of adapting to new tasks and conditions.

## 2. Sprayer design

The prototype sprayer system for canopy optimised spraying is based on a trailed air-assisted sprayer equipped with radial fan

and a piston-diaphragm pump. Radial fan is mounted at rear of the sprayer. A special designed experimental spraying arm is mounted on sprayer frame between the fan and the tank. For simplicity there is just one arm on the right side of the sprayer.



Fig. 1. Canopy optimised sprayer.

Spraying arm consists of central, side movable beam on which end a central holder for upper and lower arm part is connected. Upper arm part and lower arm part consist of two square tubes of which one is of smaller dimensions and inserted into the another. In this way extendable beam is provided on which end the spray unit is mounted. Spray unit is designed in such a way that air spouts with nozzles can be swing up and down  $\pm 35^\circ$ . There is also one spray unit mounted on the central holder in the middle. At the side of each air spout there are pesticide nozzles, controlled by solenoid valves. All degrees of freedom are hydraulically operated.

### 3. Sensing equipment

For sensing, we plan to use three sensing devices, laser scanner, RGB camera and ultrasonic sensor.



The SICK LMS 111 scanner was tested to perform well in all illumination conditions, including direct sunlight. RGB camera is Flea2 industrial camera with 1032x768 pixel resolution, 1/3" sensor and 5 mm megapixel lens. The ultrasonic sensors emit an ultrasonic pulse and measure the intensity and time of reflected sound. Leaves of the canopy are not solid target, and penetration of ultrasound in the canopy occurs. Scattered sound from the middle of the canopy is again attenuated by the leaves, but some information on canopy density and thickness is possible. For canopy detection, the following characteristics are required: (1) variable amplification due to absorption changes with distance in addition to basic fixed amplification, (2) temperature compensation, (3) RMS value of reflected signal must be calculated in intervals to evaluate canopy density and thickness, (4) very high sampling rate of microcontroller is required to distinguish between supports and canopies. Sensing distance of ultrasonic sensors is from 0.5 m to 1.5 m. This value is based on estimation of slender spindle growing system and average inter row distances.

#### 4. Degrees of freedom and inverse kinematics algorithm

The canopy optimised sprayer is designed to position the spraying nozzles and spray at a distance  $D_{\text{spray}}$  perpendicular to the canopy outline (Fig. 2). Eight degrees of freedom were selected. In contrast to the middle arm, no analytical solution exists to calculate positions of upper and lower arm, we use a nonlinear algorithm to solve the unknown variables.

#### 5. Software architecture

Software architecture is provided by several modules which run independently. Main modules are laser scanner sensing, RGB camera sensing, ultrasonic sensing, intelligent sensor fusion / learning algorithms module, spraying manipulator control module, and inverse kinematics module. All sensing modules currently run with a speed of data acquisition, thus loop times are 20 ms for laser scanner, 33 ms for RGB camera and 15 ms for ultrasonic sensors.

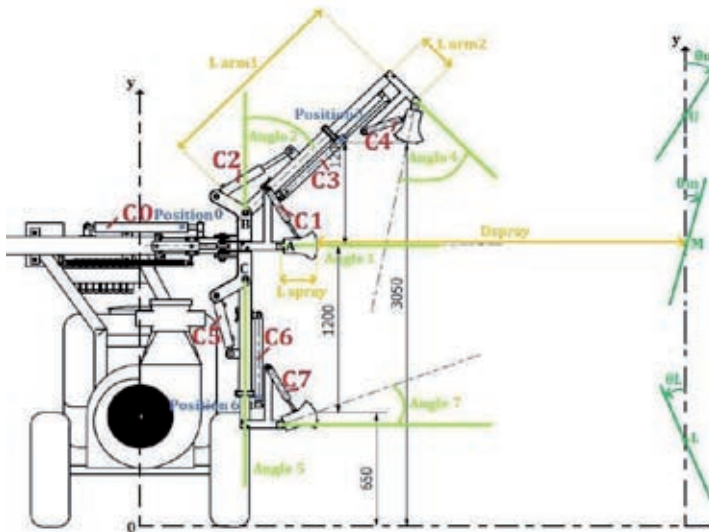

Fig. 2. Degrees of freedom of the spraying arm. Hydraulic cylinders (C0 to C7) represent degrees of freedom. Dark green lines are multidimensional surfaces fitted to the canopy.

Every sensing module stores acquired data in a table and delays it according to travel speed of the sprayer. All sensing modules send their measurement results to intelligent sensor fusion / learning algorithms module, which processes sensing information and outputs the processed sensing data to inverse kinematics module. This information contains desired positions of the spraying arm and canopy density. Loop time of inverse kinematic module is around 20 ms, depending on the current and required position of the spraying arm. Spraying manipulator control module measures current positions of all degrees of freedom every 5 ms.

All data acquisition is performed within National Instruments / Labview hardware and software. A desktop Pentium i5 computer is used for the acquisition and analysis. Fig. 1 shows part of user interface of artificial tree sensing with laser scanner in the laboratory with stationary sprayer. In the future we plan to switch to ROS middleware. A sample front panel of the laser scanner sensing module is shown in Fig. 3.

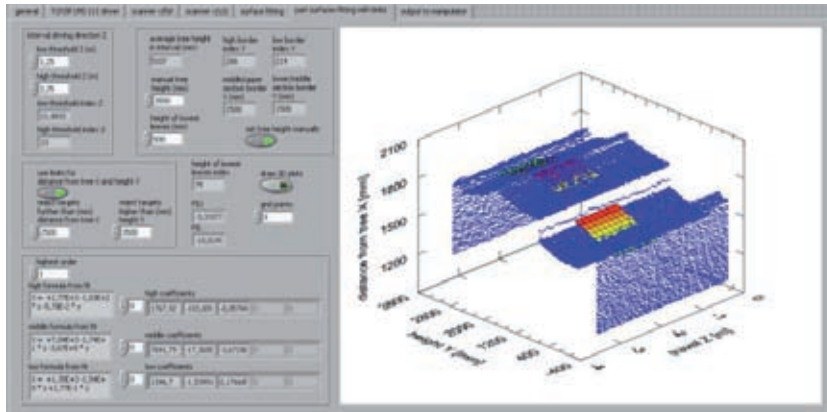

Fig. 3. Front panel of the laser scanner sensing module, stationary sprayer. Each surface corresponds to canopy surface.

## 6. Conclusions

The canopy optimised sprayer will be evaluated in the following years in apple orchards. Further design work will be focused on intelligent sensor fusion / learning algorithms and improvement of manipulator design.

## Acknowledgements

*This work was funded by the European Commission in the 7th Framework Programme (CROPS GA no 246252).*

## References

- Cross, J.V., Walklate, P.J., Murray, R.A., Richardson, G.M. (2001). Spray deposits and losses in different sized apple trees from an axial fan orchard sprayer: 1. effects of spray liquid flow rate, *Crop Protection*, vol. 20, p. 13-30.
- Byers, R.E., Hickey, K.D., Hill, C.H. (1971): Base Gallonage Per Acre. *Virginia Fruit*, vol. 60, p. 19-23.
- Pergher, G., Gubiani, R., Tonetto, G. (1997) Foliar deposition and pesticide losses from three air-assisted sprayers in a hedgerow vineyard. *Crop Protection*, vol. 16, p. 25-33.
- Pergher, G., Petris, R. (2008). Pesticide dose adjustment in vineyard spraying and potential for dose reduction. *The Cigr Ejournal*, 10, Manuscript Alnarp 08 011, vol. X.
- Solanelles, F., Escolà, A., Planas, S., Rosell, J.R., Camp, F., Gràcia, F. (2006). An Electronic control system for pesticide application proportional to the canopy width of tree crops. *Biosystems Engineering*, vol. 95, p. 473-481.
- Wangler, R.J., Connell, R.E., Fowler, K.L., Olson, R.A. (1993). *Application of smart submunition technology to agribusiness*. J.A. Deshazer, Meyer, G.E. (eds.). Proc. Spie Optics In Agriculture And Forestry, vol. 1836, p. 261-272.
- Walklate, P.J., Cross, J.V., Richardson, G.M., Murray, R.A., Baker, D.E. (2002). Comparison of different spray volume deposition models using lidar measurements of apple orchards. *Biosystems Engineering*, vol. 82, p. 253-267.



**First RHEA International Conference on  
Robotics and associated High-technologies  
and Equipment for Agriculture**  
Hosted by the University of Pisa  
Pisa, Italy, September 19-20-21, 2012



TOPIC n° 1.3

**Electronic canopy characterization and variable rate  
application in Precision Fructiculture and Viticulture**

Alexandre Escolà<sup>1</sup>, Joan R. Rosell-Polo<sup>1</sup>, Emilio Gil<sup>2</sup>,  
Ricardo Sanz<sup>1</sup>, Jaume Arnó<sup>1</sup>, Ignacio del Moral<sup>1</sup>, Jordi  
Llorens<sup>2</sup>, Joan Masip<sup>1</sup>, Eduard Gregorio<sup>1</sup>, Santiago Planas<sup>1</sup>

*Research Group on Precision Agriculture, AgrolCT & Agrotechnology*

<sup>1</sup>*Dept. of Agricultural and Forest Engineering — Universitat de Lleida. Av. Rovira  
Roure 191. 25198 Lleida, Catalonia, Spain.*

*(corresponding autor e-mail: AEscola@eagrof.udl.cat)*

<sup>2</sup>*Dept. of Agri Food Engineering and Biotechnology – Universitat Politècnica de  
Catalunya. Av. Canal Olímpic, 15, Edifici ESAB. 08860 Castelldefels (Barcelona),  
Catalonia, Spain.*

**Keywords:** LiDAR, ultrasounds, variable rate sprayer, dose  
adjustment, precision agriculture.

---

**Abstract:**

Information on fruit tree crops canopy is very useful for many purposes in crop management. Several non-destructive methodologies have been developed to estimate canopy volume and Leaf Area Index using ultrasonic or LiDAR sensors (Light Detection And Ranging). The implementation of an RTK-DGPS receiver allows geo-referencing all the information obtaining highly detailed digital models of the vegetation. This information could be used to help farmers and advisors to choose the right dose rate for their orchards and vineyards using dedicated software (DOSAVIÑA and DOSAFRUT) but could also be of interest for other purposes.

Another use of this information is to adjust the dose rate on a variable rate real-time basis. Two prototypes have been implemented for orchard and vineyard on-the-go applications. Both prototypes are divided in a) a canopy characterization system to estimate the canopy volume, b) an electronic





controller to run the control algorithm and, c) several actuators (valves) to modify the sprayed flow rate.

The results obtained with the prototypes show clear savings in relation to a conventional orchard or vineyard sprayer. The variable rate prototype sprays an adapted flow rate taking into consideration the macro and micro variability of the canopy size throughout the orchard and vineyard while conventional sprayers keep spraying a constant flow rate regardless the size and even the absence of canopy.

The total savings of these systems depend on the training system of the canopies and the variability along the rows. The higher the variability, the higher the savings. Moreover, the spray boom is divided into 3 independent sections in height so that different spraying flow rates could be applied according to the specific variability of each level.

---

## 1. Introduction

In the Research Group on Precision Agriculture, AgroICT & Agrotechnology we have been using ultrasonic and LiDAR (Light Detection And Ranging) sensors to characterize canopies in vineyards and orchards. The application of these first developments was focused on adjusting the dose rate of plant protection products. The characterization was firstly based on estimating the canopy width at different heights to determine the cross-sectional canopy area for each scan. As the sensors were moved along the alleys, those cross-sectional areas turned into canopy volume. The dose adjustment was formerly based on the Tree Row Volume (TRV) principle, converting canopy volume into the appropriate flow rate to correctly distribute the required plant protection product rate (Rosell et al., 2009; Sanz et al., 2011). This technology was implemented in a real-time variable rate sprayer prototype for orchards and another one for vineyards. A subsequently improvement was the use of LiDAR sensors to estimate the Leaf Area Index (LAI) and the percentage of gaps along the rows. This approach was used in a decision support system for vineyards (DOSAVIÑA) and for fruit crops (DOSAFRUT). In this communication we present the

last improvements of the canopy characterization systems, dose adjustments decision support systems and the variable prototypes.

## 2. Canopy characterization

The characterization of treetops and tree plantations using LiDAR sensors is based on the emission of infrared laser light pulses. The sensor determines the distance from the sensor to the canopy. The sensor used sends pulses of laser light in one plane (2D), changing the angle of emission between consecutive pulses. When moving the sensor, successive detection planes of the object are obtained, resulting in a 3D characterization. The result of the measurement consists on a set or cloud of points corresponding to the impacts of light on the constituents of plants. The obtained point cloud become a three-dimensional model of the plant and is the basis for obtaining various geometric and structural parameters of this. In the present work, the point clouds have been obtained by the linear displacement of LiDAR along the tree rows and geo-referencing the obtained points with centimetre accuracy by means of the integration of RTK-DGPS with an inertial sensor to provide more accurate measurements (Fig. 1 left). Geostatistical processes were used create maps of the scanned crops (Fig. 1 center and right).

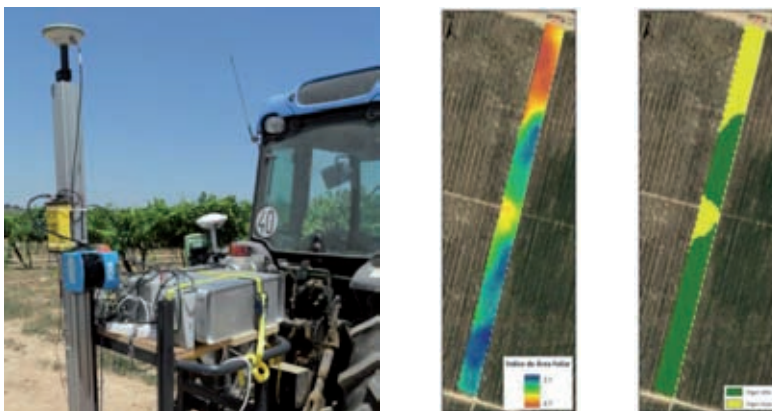

Fig. 1. LiDAR based system to scan canopy rows equipped with an RTK-DGPS receiver and an inertial unit (left) and the obtained LAI map (center) and vigour zones map (right).



### 3. Decision support systems

DOSAVIÑA is a Decision Support System developed to determine the optimal application volume rate for vineyard spraying with conventional sprayers. This decision tool is based on multiple data obtained after several years in real working conditions using different types of sprayers in vineyards, and includes a complete data base about crop characteristics (structure, crop stage, leaf area, leaf area index, leaf area density, etc). The computer program has been developed with the objective to generate an easy-to-use and useful tool and is able to determine the optimal volume rate to apply in vineyards, based on different calibration procedures. DOSAVIÑA also quantifies, in terms of losses of liquid, the effect of all parameters involved during the application process (Gil et al., 2009). The obtained results after five years of use in real conditions in the field show the interest of DOSAVIÑA. Average reduction about 39% in volume rates has been obtained and, consequently, the same reduction has been achieved in terms of plant protection products (Gil et al., 2011).

DOSAFRUT was formerly based on DOSAVIÑA and was adapted to the specifications of fruit tree crops. Subsequently, DOSAFRUT have been taking advantage of the use of lidar sensors and pictograms to help farmers to better adjust the dose rate to their specific situations. DOSAFRUT is available online at [www.dosafrut.com](http://www.dosafrut.com).

### 4. Variable rate sprayers

The developed prototypes (Fig. 2) are able to modify the spray application rate according to the target geometry of fruit or vine canopies. Variations in canopy width and canopy cross-sectional area along the crop row are electronically measured by either 3 ultrasonic (Escolà et al., 2011) or a LiDAR sensor. The received signals are processed according to an algorithm to calculate the appropriate flow rate. The sprayed flow rate is modified by means of high frequency electromagnetic valves in real-time. The objective during the whole process is to keep a constant

application rate per unit of canopy volume (Solanelles et al., 2006; Gil et al., 2007; Llorens et al., 2010). An example of the resulting variable rate application is shown in Fig. 3. The sprayed volume line follows the canopy volume line while a constant flow rate application sprays the same amount of product regardless the size of the canopy.



Fig. 2. Variable rate prototype sprayer for orchards (left) and for vineyards (right).

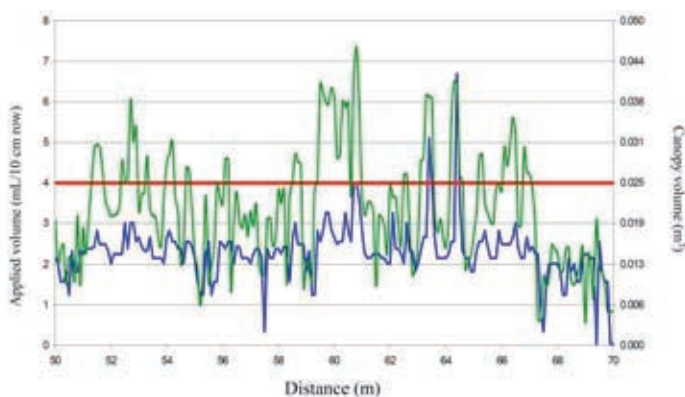

Fig. 3. Canopy volume (green line), variable rate sprayed volume (blue line) and constant flow rate application (red line) evolution along a vineyard row.

## 5. Results and conclusions

The use of new technologies in precision crop protection allows better adjusting dose rates to specific orchard or vineyard conditions. Using the developed decision support systems together with conventional sprayers have been proven to reduce the amount of plant protection products without affecting the



efficacy of the treatments. Using variable rate sprayers is a good alternative to automatically adjust doses according to canopy variability in real time. These results are in line with the main objective of the European Directive of Sustainable Use of Pesticides.

## Acknowledgements

*The research presented have been done in the framework of research projects Pulvexact (AGL2002-04260-C04-02), Optidosa (AGL2007-66093-C04-03), Safespray (AGL2010-22304-C04-03) funded by the Spanish Ministry of Science and Innovation and the European Union through the FEDER funds.*

## References

- Escolà, A., Planas, S., Rosell, J.R., Pomar, J., Camp, F., Solanelles, F., Gràcia, F., Llorens, J., Gil, E. 2011. *Performance of an ultrasonic ranging sensor in apple tree canopies*. Sensors 11, 2459-2477.
- Gil, E., Escolà, A., Rosell, J.R., Planas, S., Val, L. 2007. *Variable rate application of plant protection products in vineyard using ultrasonic sensors*. Crop Prot. 26, 1287-1297.
- Gil, E., Escolà, A. 2009. *Design of a decision support method to determine volume rate for vineyard spraying*. Applied Engineering in Agriculture 25(2), 145-151.
- Gil, E., Llorens, J., Landers, A., Llop, J., Giralt, L. 2011. *Field validation of dosaviña, a decision support system to determine the optimal volume rate for pesticide application in vineyards*. European Journal of Agronomy 35(1), 33-46.
- Llorens, J., Gil, E., Llop, J., Escolà, A. 2010. *Variable rate dosing in precision viticulture: Use of electronic devices to improve application efficiency*. Crop Protection 29, 239-248.
- Rosell, J.R., Sanz, R., Llorens, J., Arnó, J., Escolà, A., Ribes-Dasi, M., Masip, J., Camp, F., Gràcia, F., Solanelles, F., Pallejà, T., Val, L., Planas, S., Gil, E., Palacín, J. 2009. *A tractor-mounted scanning LIDAR for the non-destructive measurement of vegetative volume and surface area of tree-row plantations: A comparison with conventional destructive measurements*. Biosystems Engineering 102, 128-134.
- Sanz, R., Llorens, J., Escolà, A., Arnó, J., Ribes-Dasi, M., Masip, J., Camp, F., Gràcia, F., Solanelles, F., Planas, S., Pallejà, T., Palacín, J., Gregorio, E., Del Moral, I., Rosell, J.R. 2011. *Innovative LIDAR 3D dynamic measurement system to estimate fruit-tree leaf area*. Sensors 11, 5769-5791.
- Solanelles, F., Escolà, A., Planas, S., Rosell, J.R., Camp, F., Gràcia, F. 2006. *An electronic control system for pesticide application proportional to the canopy width of tree crops*. Biosystems Engineering 95, 473-481.



**First RHEA International Conference on  
Robotics and associated High-technologies  
and Equipment for Agriculture**  
Hosted by the University of Pisa  
Pisa, Italy, September 19-20-21, 2012



**Sustainable plant protection in fruit growing: the  
development of a Crop Adapted Spray Application system**

**Paolo Balsari<sup>1</sup>, Paolo Marucco<sup>1</sup>, Mario Tamagnone<sup>1</sup>,  
Grzegorz Doruchowski<sup>2</sup>, Jan Van de Zande<sup>3</sup>, Marcel  
Wenneker<sup>4</sup>**

<sup>1</sup>*DEIAFA – Università di Torino, Via Leonardo da Vinci 44, 10095 Grugliasco (TO),  
Italy (e-mail: paolo.balsari@unito.it)*

<sup>2</sup>*InHort, Research Institute of Horticulture, Dept of Agro Engineering, ul. Konstytucji  
3 Maja 1/3, 96-100 Skierniewice, Poland (e-mail: grzegorz.doruchowski@inhort.pl)*

<sup>3</sup>*Wageningen University and Research Centre, PRI B.V., Wageningen, the  
Netherlands (e-mail: jan.vandezande@wur.nl)*

<sup>4</sup>*Wageningen University and Research Centre, APR, Randwijk, the Netherlands (e-  
mail: marcel.wenneker@wur.nl)*

**Keywords:** spectral analysis, crop identification, ultrasonic sensor, variable rate application, spray drift.

---

**Abstract:** In the ambit of ISAFRUIT project ([www.isafruit.org](http://www.isafruit.org)) a prototype model of air-assisted sprayer enabling to ensure precise, efficient and safe spray application in orchards according to actual needs and with respect to the environment was designed and constructed. The sprayer prototype integrates three different modules: a Crop Health Sensor (CHS), able to detect the presence of crop diseases through reflectance imaging; a Crop Identification System (CIS), based on ultrasonic sensors, allowing to individuate the presence of the target in front of the sprayer, to assess the canopy size and density and therefore to adapt in real time the volume application rate to the target characteristics; an Environmentally Dependent Application System (EDAS), equipped with a DGPS navigation system and a sonic anemometer, able to automatically manage air flow and spray quality according to environmental circumstances. Laboratory tests provided a first set of results for basing the development of a crop health sensor to be mounted on the sprayer, but CHS was actually not



operated on the Crop Adapted Spray Application (CASA) sprayer prototype. CIS was tested in the field and results pointed out spray savings between 31% and 82% with an improved spray quality distribution and maintaining the same level of biological efficacy achieved with conventional application. Results of field tests made operating EDAS showed that the optimal combination of air settings and nozzles allowed to drastically decrease the amount of spray drift produced, up to more than 80% with respect to the conventional spray application.

---

## **1. Introduction**

In recent years the environmental aspects related to pesticide spray application in agriculture have become more and more relevant and also the European legislation has focused on the reduction of pesticide use and on the environmental safeguard, especially through the issue of the EU Directive 128/2009/EC on sustainable use of pesticides. Development of new technologies enabling to optimise spray distribution according to target characteristics and to prevent contamination of off-target sites is a key element for matching these requirements. In the ambit of EU project ISAFRUIT ([www.isafruit.org](http://www.isafruit.org)), that was carried out between 2006 and 2010, a Crop Adapted Spray Application (CASA) sprayer prototype was developed in collaboration between DEIAFA – University of Torino (Italy), Research Institute of Pomology and Floriculture (since 2011 Research Institute of Horticulture) in Skierniewice (Poland) and Wageningen University and Research Centre (the Netherlands). Objective was to adjust automatically the spray application parameters (spray volume rate, spray quality, air setting) in real time according to target characteristics, to crop health status and to environmental circumstances in order to reduce spray input while maintaining a high level of biological efficacy of treatments and hence minimising risks of environmental contamination.

## **2. Materials and methods**

CASA sprayer prototype consists of three sub-systems: 1) a



Crop Health Sensor (CHS) aimed at assessing the presence of diseases on crops in order to support decision making on spray application (Van de Zande et al., 2007); 2) a Crop Identification System (CIS), addressed to identify canopy size and density in order to adapt the volume application rate in the field (Balsari et al., 2007); 3) an Environmental Dependent Application System (EDAS), enabling to automatically manage the spraying parameters (air settings and spray quality) according to wind conditions and sprayer position with respect to sensitive areas (Doruchowski et al., 2007). CIS and EDAS were installed on the frame of a Hardi Arrow 1000 air-assisted sprayer, equipped with a double radial fan (540 mm diameter) that was then adapted especially in the air conveyor and in the distribution elements (adjustable air spouts) in order to obtain an even vertical spray pattern and an appropriate air flow at different heights on both sides of the machine (Fig. 1). The sprayer was equipped with 6 air spouts on each machine side; each spout was equipped with a set of four nozzles, individually controlled by pneumatic on-off valves.



Fig. 1. ISAFRUIT CASA sprayer prototype equipped with CIS and EDAS systems.

### *2.1 Crop Health Sensor (CHS)*

The CHS was studied at Wageningen University and Research Centre (the Netherlands) on the basis of the experiences acquired in crop sensing techniques for arable crops (Schut, 2003), using reflectance imaging and hyperspectral analysis at leaf level. Spectral analysis experiments were carried out in laboratory on healthy and infected apple leaves in order to



identify specific wavelengths enabling to discriminate leaf status and to detect the presence of diseases at very early infection stages.

### *2.2 Crop Identification System (CIS)*

The CIS, based on six ultrasonic sensors, was developed at DEIAFA - University of Torino in collaboration with COBO-3B6 company (Castelletto Ticino (NO), Italy). The sensors were mounted at the front of the sprayer, on both sides of the machine, at three different heights. Sensors, analysing the ultrasound echo signal, provide two types of information: a) the distance between the sensor and the target, in order to know if the target was present or not in front of the sprayer and to assess the thickness of the canopy; b) the density of the vegetation, mainly (but not only) dependent on the number of layers of leaves, that is calculated as an index value based on the intensity and duration of the echo signal. Based on sensors information, for each spray band, thanks to a dedicated software, the operating pressure and the number of active nozzles are then automatically adjusted in order to achieve the necessary flow rate according to the forward speed of the sprayer. CIS was tested during the whole 2008 season in three different apple orchards in order to assess spray savings and spray quality distribution compared to a reference conventional spray application made applying  $850 \text{ l ha}^{-1}$ .

### *2.3 Environmentally Dependent Application System (EDAS)*

The EDAS was developed at Research Institute of Horticulture (Skierniewice, Poland) in cooperation with Agrocom Polska (Zedowice, Poland). The system measures wind velocity and direction by an ultrasonic anemometer and identifies the sprayer position (DGPS) in relation to the orchard edges and sensitive areas in orchard surroundings. Based on the acquired data actions are taken to prevent spray drift: the spray quality is automatically adapted by selecting the fine or the coarse spray nozzles, and the air flow is adjusted in real time, individually for the left and right side of the sprayer, thanks to a diaphragm leaf

shutter fixed on the fan inlet and to an air vane in the air conveyor (Fig. 2). Spray drift measurements in the field according to ISO 22866 were carried out in a pear orchard cv Conference comparing the CASA sprayer equipped with EDAS and a conventional cross-flow sprayer equipped with hollow cone nozzles. Nine different scenarios for spraying the three outer rows of the orchard using CASA/EDAS sprayer were examined, considering different combination of nozzle types and air settings used along the three passes.

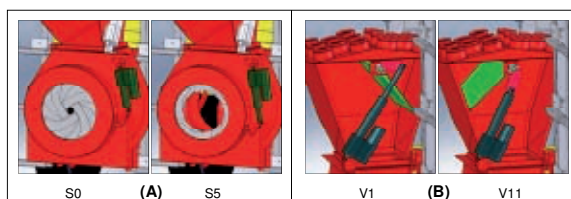

Fig. 2. Airflow adjustment device of the Environmentally Dependent Application System: (A) diaphragm leaf shutter on the inlet of radial fan (positions: S0 – closed; S5 - fully open); (B) air vane in the air collector (positions: V1 – no air to the right section and full air to the left section; V11 – no air to the left section and full air to the right section).

### **3. Results and conclusions**

#### *3.1 Crop Health Sensor (CHS)*

Experimental results pointed out the possibility to individuate specific reflectance wavelengths (e.g. 670, 675, 680, 750 nm) for which the NDVI (Normalised Difference Vegetation Index) can be calculated for discriminating apple cultivars and healthy versus infected leaves. Disease detection (apple scab, *Venturia inaequalis*) resulted possible just 4 hours after infection and this opens new perspectives for crop protection strategies.

#### *3.2 Crop Identification System (CIS)*

Results of field tests pointed out that using CIS it was possible to reduce the volume sprayed between 45% and 82% at early growth stages and between 31% and 64% at full vegetation stage (Fig. 3). CIS also enabled to improve spray deposition



within the canopy and to reduce spray ground losses while disease control efficacy resulted not significantly different from the one achieved making a conventional spray application.

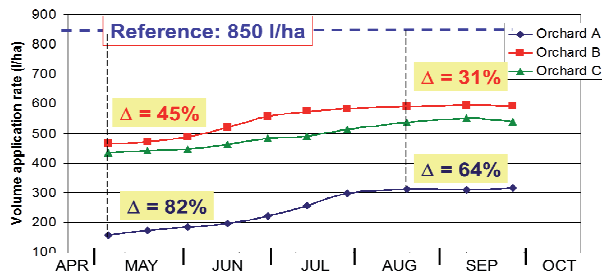

Fig. 3. Volume application rates used across the season with a sprayer controlled by Crop Identification System (variable rate application), calibrated for 850 l/ha as a reference volume, in three different orchards: (A) 2-year Gala cv., trees 2,2 m tall; (B) 11-year Red Chief cv., trees 4,0 m tall; (C) 13-year Gala cv., trees 4,0 m tall.

### 3.3 Environmentally Dependent Application System (EDAS)

Combining the airflow reduction with the low-drift nozzle selection for spraying the outer rows of the orchard allowed the EDAS equipped sprayer to reduce up to 83% the average spray drift, measured beside the orchard, with respect to the conventional cross-flow sprayer equipped with hollow cone nozzles.

#### References

- Balsari P, Doruchowski G, Marucco P, Tamagnone M, Zande J C van de, Wenneker M. 2007. *The development of a Crop Identification System (CIS) able to adjust the spray application to the target characteristics*. Proc. SuProFruit 2007 – 9th Workshop on Spray Application Techniques in Fruit Growing. Alnarp, Sweden 12-14 September: 73-18.
- Doruchowski G, Holownicki R, Godyn A, Swiechowski W, Jedrachowicz T, Balsari P, Marucco P, Zande J C van de, Achten V, Wenneker M. 2007. *Environmentally Dependent Application System (EDAS) for adjusting the spray application parameters according to the environmental circumstances in orchards – ISAFRUIT project*. Proc. SuProFruit 2007 – 9th Workshop on Spray Application Techniques in Fruit Growing. Alnarp, Sweden 12-14 September: 15-16.
- Schut A G T. 2003. *Imaging spectroscopy for characterization of grass swards*. PhD Thesis Wageningen University, Wageningen, The Netherlands. 264p
- Zande J C van de, Wenneker M, Meuleman J, Achten V, Balsari P, Doruchowski G. 2007. *Development of a Crop Health Sensor to minimise spray applications in apple*. Proc. SuProFruit 2007 – 9th Workshop on Spray Application Techniques in Fruit Growing. Alnarp, Sweden 12-14 September: 13-14.



### TOPIC n° 1.3

## **The innovative RHEA airblast sprayer for tree crop treatment.**

**Marco Vieri<sup>1</sup>, Riccardo Lisci<sup>1</sup>, Marco Rimediotti<sup>1</sup>, Daniele Sarri<sup>1</sup>**

*<sup>1</sup>Dept. of Economics, Engineering, Science and Technologies in Agriculture and Forestry - University of Florence - Italy*

**Keyword:** Pesticide sustainable use, innovative machine for pesticide application in tree crops

---

**Abstract:** Authors present achievements in the research of appropriate solution about the RHEA sprayer for tree crops. The scenario of the most innovative technologies on airblast sprayer configuration has been analyzed and each solution on devices has been evaluated. UF unit has designed a semi-mounted sprayer applied to small autonomous tractor equipped with sensor able to recognize the presence, shape and thickness of the various horizontal bands of the canopy by adjusting the type of spraying. Spray application it is so variable separately on each band in term of direction of diffusors, airblast flow rate and liquid dose adequate to the presence or thickness of the canopy. The new RHEA airblast sprayer concept, in addition to the implementation of automated functions, has the aims to apply the rules specified by the European Union to reduce pollution caused by distribution of PPP (plant protection products).

---

### **Introduction**

The sustainable use of PPP and the need of a renewed integrated system of agricultural knowledge and management in course of evolution by the Precision Agriculture approach moved the design of the EU FP7 RHEA Project (Robot fleets Highly for Effective Agriculture and forestry management).

The present report is related the third case study considered in the RHEA Project that involve the application of sprayed



chemicals to the woody crops canopy. A huge amount of researches has been done on spray chemical optimization and especially since the 1980s to adapt the spraying techniques to the crops.

Advances in sensors, actuators and electronic controllers have facilitated the boarding of electronics in sprayers for tree and bush crops: first step was the interruption of liquid flow rate when no foliage it is detected; further developments were achieved with the control on the different vertical bands of canopy. The next step was matching the sprayed flow rate proportional to the canopy width using ultrasound sensors and later the laser LIDAR (Light Detection And Ranging).

The spray jet, the dose and air energy applied, shall be in fact adequate to the morphological features of the treated canopy (Pergher et al, 2002). Other important researches were devoted to the appropriate sprayer scheme in order to better fit the treatment in variable canopy shape or weather condition (Escolà et al., 2007; Doruchowski et al., 2011); Hoçevan et al. (2010) investigated on a variable inclination and positioning of the spray diffusors to better fit air spray jet onto the canopy.

Latest studies have taken into account the georeferenced 3D prescription maps application to make an optimized Variable Rate Treatment; even on Olive tree crops (Moorthy, 2011; Pérez-Ruiz et al., 2011). It also permits to have the telemetric traceability of applied dose on each step of the canopy annual growth. More detailed references on state of the art are reported in Vieri M. et al., 2012.

## **Materials and methods**

The primitive configuration of the RHEA ground mobile units taken into consideration very small vehicles with 200-400 kg mass and less than 15 kW power, operating at a forward speed of 1.5 m/s and with only one operating arm.

In particular, for canopy treatment, this is really feasible only for spot spraying e.g. in the insects control, but not appropriate for other diseases like mushroom etc. In these cases arise at least two problems: one is the dosage that, even in a modern intensive

tree plant with an average of 5000 m<sup>2</sup> of canopy volume per hectare, requires not less than 100-200 l/ha; second it is the necessity of air assist device to well put the chemical sprayed droplets inside the canopy and the inappropriate use of only one manipulator (spray diffusor) that at the prescribed forward speed produce an unacceptable unequal sinusoidal application.

On these and other consideration the RHEA Consortium approved a more suitable ground mobile unit (GMU) with these specifications: 4x4 wheel drive, CVT transmission, 37.3 kW gross power, 10% of which available as electric power, with a mass of 1600 kg, 3 hitch points lift and standard 52 rad/s p.t.o. That make it possible to adopt a ready to common use and innovative air assisted sprayer.

Another important choice has been the Olive intensive plant for the final demonstration; this decision it is due to the fact that Olive crop is quite comparable to both modern Orchard and Woody Tree Crops as mentioned in the RHEA Project Proposal. Plantation scheme is 4.0 m inter-row and 1.5 distances on the row to reach a foliar wall as flat and regular as possible.

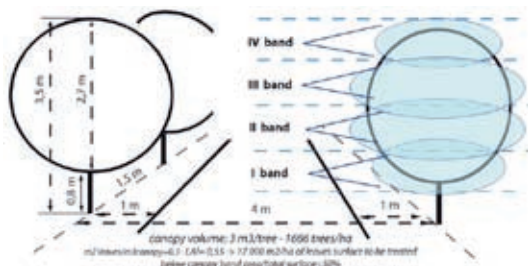

Fig.1 - RHEA Olive demonstration plant scheme

On these aims we investigated different solutions in terms of spraying and air vector devices: the Proptec Rotary Sprayer module, The Sardi fan module, the Tangential cross-flow module, the Oktopus spraying technique.

Where also analyzed: the equipment configuration as single side or double side and number of modules, the device system (DS) and the control system or Low Level Actuation System (LLAS), the main parameters controlled: spray cloud features, liquid flow rate, air flow rate and air jet direction.





Where finally defined rules for each devices to better fit optimum spray features on each vertical bands of the canopy.

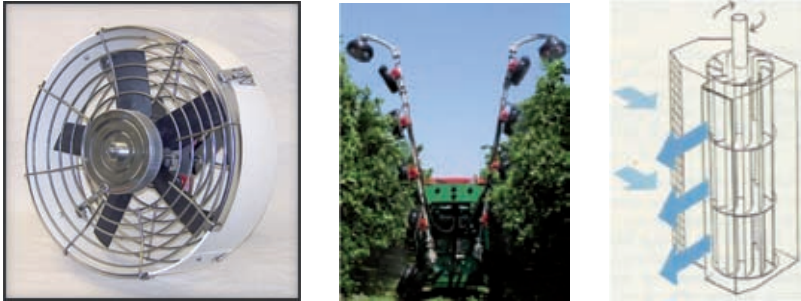

Fig. 2 a,b,c: Protec, Sardi and Tangential (cross flow) fans.

**RULES**

spray module & ultrasonic sensor	Scenary 1				Scenary 2				Scenary 3				Scenary 4			
	canopy	spray	inclination	air	canopy	spray	inclination	air	canopy	spray	inclination	air	canopy	spray	inclination	air
1	ok	yes	0°	yes	no	yes	-15°	yes	no	no	-15°	no	no	no	-15°	no
2	ok	yes	0°	yes	ok	yes	0°	yes	no	yes	0°	yes	no	no	0°	no
3	ok	yes	0°	yes	ok	yes	0°	yes	no	yes	0°	yes	no	no	0°	no
4	ok	yes	0°	yes	no	yes	+15°	yes	no	no	+15°	no	no	no	+15°	no

Fig. 3 – Operative rules adopted on RHEA airblast sprayer

### 3. Results and conclusions

The RHEA robot airblast sprayer for precision tree crops treatment represent an unique innovative integrated system that includes suggestions derived from advanced researches.

The entire spray robot module has both remote and proximal controls; remote to control tractor and proximal to control spraying. This choice has a double aim to have an innovative sprayer that can be used and tested as independent autonomous equipment also with normal tractors.

The spraying configuration provides 8 different vertical bands of independent treatment with separate controls of chemical dose applied and air flow direction and rate. It consists in 30 controls devices (8 butterfly valve at the air conveyor; 1 main

butterfly valve at the manifold fan inlet; 4 actuator to control upper and lower outlet diffuser inclination; 16 solenoid valve; 1 pressure valve), 8 controller and 1 PLC, 12 sensors (1 for forward speed ; 1 for liquid pressure, 8 Ultrasound Sensors, 1 for tank level, 1 for pressure).

The 8 US sensors could be replaced by on board LIDAR or by a remote control directly send by the HLDMS (High Level Decision Making System) that could use the LIDAR on the scouting Aerial Unmanned Vehicle to provide a 3D prescription map able to command the different operating system of the air sprayer in the different vertical bands.



Fig. 4 – the 1° RHEA airblast sprayer prototype (left).

Fig. 5 a,b,c – the “butterfly valves” to control airblast on each horizontal band (right).

The expected chemical dosage saving is ranging from 50 and 70% of the conventional rate of application maintaining the right quality and quantity of deposition on the foliage.

The next two years of tests will give data on technical and operative characteristic of this complex system.



Fig. 6 – tilt diffusor (*left*) with double nozzles (*right*).

Particular interest is placed on airjet vector characterization and its effect on the canopy by means of the butterfly valve control on each single side band.

#### Acknowledgements

*Special thanks are due to NOBILI Agricultural Equipment of Molinella (Bo) for the precious support and also to our colleagues Mr. Giancarlo Cosi and Ms. Angèle Cannizzo for the special commitment and passion to develop the RHEA air sprayer prototype devices.*

#### References

- Chen Y. (2010). Development of an Intelligent Sprayer to Optimize Pesticide Applications in Nurseries and Orchards. Dissertation for the Degree Doctor of Philosophy in the Graduate School of The Ohio State University.A.
- Doruchowski G. & Holownicki R. (2000). Environmentally friendly spray techniques for tree crops. *Crop Protection* 19, 617-622.
- Escolà A., Camp F., Solanalles F., Llorens J., Planas S., Rosell J.R., Gràcia F., Gil E. & Val L. (2007). Variable dose rate sprayer prototype for dose adjustment in tree crops according to canopy characteristics measured with ultrasonic and laser LIDAR sensors. *Proceedings ECPA-6th European Conference on Precision Agriculture* pp 563-571.
- Hočevar M., Sirok B., Jeicic V., Godesa M., Lesnik M. & Stainko D. (2010). Design testing of and automated system for targeted spraying in orchards. *Journ. Of Plant Diseases and protection* 117(2) 71-79.
- Moorty I., Miller J.R., Berni J.A.J, Zaro-tejada P., Hu B. & Chen J. (2011). Field characterization in Olive (*Olea Europaea L.*): tree crown architecture using terrestrial laser scanner data. *Agric.Forest Meteorol.* 151, 204-214.
- Pegher G., Balsari P., Cerruto E. & Vieri M. (2002). The relationship between vertical spray pattern from air assisted sprayers and foliar deposit in vine canopies. *Aspects of Applied Biology* 66, *International Advances in Pesticide Application*.
- Pérez-Ruiz M., Aguera J., Gil J.A., Slaughter D.C. 2011. Optimisation of agrochemical application in olive groves based on positioning sensors. *Precision Agriculture* 12, 564-575.
- Vieri M., Sarri D., Rimediotti M., Lisci R., Peruzzi A., Raffaelli M., Fontanelli M., Frasconi C., Martelloni L. (2012). *RHEA project achievement: an innovative spray concept for pesticide application to tree crops equipping a fleet of autonomous robots*. *Proceedings CIGR – AgEng2012 Conference Valencia* , July 8-12, 2012.

**Session 2:**  
**Device innovation**





**TOPIC n° 1.3**

**Automatic diseases detection in grapevine  
under field conditions**

**Roberto Oberti<sup>1</sup>, Paolo Tirelli<sup>1,2</sup>, Massimo Marchi<sup>1,2</sup>,  
Aldo Calcante<sup>1</sup>, Marcello Iriti<sup>1</sup>, Alberto N. Borghese<sup>2</sup>**

<sup>1</sup>*Department of Agricultural and Environmental Sciences -DiSAA, Università degli Studi di Milano, via Celoria 2, Milano, 20133 Italy (roberto.oberti@unimi.it)*

<sup>2</sup>*Applied Intelligent Systems-AIS Lab, Department of Computer Science, Università degli Studi di Milano, via Celoria 26, Milano, 20133 Italy (borghese@dsi.unimi.it)*

**Keywords:** disease detection, precision pest-management, multispectral imaging, proximal sensing, grapevine

---

**Abstract:** In current farming practice, pesticides are typically applied uniformly to the field despite several pests and diseases exhibit an uneven spatial distribution, especially at early stages of development. Pesticides are recognised to play a major role in environmental and production costs of agriculture activity, as well as in public concerns about products wholesomeness. There is then a growing interest in developing suitable techniques and equipment aimed to selectively target the application of pesticides where and when needed by the crop. One of the tasks of CROPS UE-project is to investigate such an approach by developing robotic targeting of pesticides distribution on infected areas. This will include a disease symptoms sensing system, and in this work we explore the use of a machine vision to accomplish this task on grapevine canopy under field conditions. As case studies we consider here the automatic detection of symptoms of two major grapevine diseases: powdery mildew (*Erysiphe necator*) and downy mildew (*Plasmopora viticola*) on leaves.

---

### **1. Introduction**

Pesticides are typically applied uniformly despite several pests and diseases exhibit an uneven spatial distribution, with patchy-structures evolving around discrete foci, especially during early stages of development. Grapevine is not an exception and, in current viticulture practice fungicides are uniformly applied to the vineyard according a spraying calendar, commonly based on regular and frequent fungicide applications, more rarely triggered by experts decisions or objective



data. This continuous protection approach can easily result in ten to fifteen treatments per season, often at application rates of 500-1000 dm<sup>3</sup>/ha each, for many vineyards in some of the most advanced wine-producing regions worldwide. Pesticides are also recognised to play a major role in environmental pressure, production costs and in public concerns about healthiness and wholesomeness of products. There is then an increasing interest in developing suitable techniques and equipment able to selectively target the application of pesticides where and when needed by the crop, with the aim of preventing or inhibiting the establishment of the infection and its epidemic spread to the whole field.

One of the tasks of UE funded project CROPS ([www.crops-robots.eu](http://www.crops-robots.eu)) is to investigate such approach by developing robotic targeting of crop protection on areas detected as infected or susceptible to be. Among possible sensing technics for disease symptoms detection, proximal optical sensing has specific characteristics especially relevant for field applications on grapevine and other fruit-tree crops. In particular, it can inspect the vertical structure of the canopy, allowing for potential on-the-go detection of early symptoms even at sub-centimetre scale.

In this work we explore the possible use of a machine vision to accomplish this task in vineyard, relying on detecting the optical modifications induced by two major grapevine fungal diseases powdery mildew (PM) and downy mildew (DM) on leaves.

## **2. Materials and methods**

### ***2.1 Plant material and diseases assessment***

A set of field measurements were carried out between May and July 2011 in the area of Garda Lake (45.5°N, 10.5°E), Italy. Six experimental plots, each of 15 plants of grapevine (*V. vinifera*, cv Gropello) were obtained in two commercial vineyards: plots group A in Raffa di Puegnago, and group B in Tuscolano Maderno. All plots were managed according the farming practice adopted in the hosting vineyards, except for pesticides treatments. DM and PM were artificially inoculated in plots A and B, respectively, in order to produce traceable, localized and possibly subsequent sprouts of fungal diseases during the measurements period. DM symptoms at different stages were obtained on leaves in two out of three plots of group A, while powdery mildew symptoms at different stages were obtained on leaves in one out of three plots of group B. Experimental plots were regularly monitored by plant pathologists through visual scouting and occurrence of disease and position of symptoms were recorded.



Symptoms intensity was rated by evaluating the growth stage of fungal colonies on leaf surface, and disease severity was assessed as the average percentage of the leaf area in the focus showing symptoms. For the limited aims of this study, an arbitrary and qualitative scale was used by designating as: initial symptoms, those corresponding to small (5 mm in diameter) and sparse (less than 1% of leaf surface affected on five leaves around the focus) fungal structures; medium intensity symptoms, those exhibiting visible patch-structures (10-15 mm in diameter) with a partly diffused focus (less than 10% of leaf surface affected); advanced symptoms, with extended colonies (20-50 mm) of mature or partly sporulating fungal structures affecting 10% or more of leaf tissue in the neighbor of disease focus.



Fig. 1. Instrumented field trolley hosting the acquisition system. Canopy imaging is done inside a tunnel structure providing background regularization and diffuse illumination of the measured area

## ***2.2 Field measurements setup***

Field acquisition were done by moving an instrumented trolley along the grapevine rows within the experimental plots. The trolley (Fig.1) held a tunnel structure aimed to cover the imaged area of the canopy with two goals: to provide background regularization and avoid multiple rows viewing by means of a black, low-reflective shield; to avoid specular reflection spots on foliage and to homogeneously illuminate the measured area with was a white, light-diffusing shields used as roof and lateral walls. The instrumented trolley hosted the electronic apparatus used for the measurements. In particular, a multi-sensor acquisition system was used which included: an RGB color camera (acA1300, Basler, Germany); a VIS-NIR hyperspectral system (ImSpector V10, Specim, Finland); an R-G-NIR multispectral camera



(MS4100, DuncanTech, USA). In this study the data acquired with the latter are only considered. The R-G-NIR multispectral camera acquires 1912x1076 pixels, 8 bit images in three distinct spectral channels: green (540nm), red (660nm) and near infrared (800nm). The canopy area imaged was about 1.25x 0.7 m, resulting in a spatial resolution of about 0.6 mm/pixel.

### ***2.3. Diseases detection algorithm***

Among multispectral images, two sets of 15 images each, containing DM and PM, respectively, were chosen. The dataset covered a range of diseases severity, leaf age, natural light conditions and other possible interfering factors as any abnormal tissue pigmentations. Within the images and according to plant pathologist classification, subregions of 10x10 pixels (ROIs) containing homogeneous tissue were manually selected. The number of ROIs for each class was chosen to obtain a balanced distribution among healthy (20 ROIs), diseased tissue at different PM and DM stages (20 ROIs each), and abnormally illuminated or pigmented tissue (10 ROIs). The identified ROIs were used to define the disease detection algorithm and to train the classification parameters.

Raw pixels intensity in each channel is normalized using two reflectance references (spectralon 50% and 99%) included in the image field. Secondly, the resulting image is then locally normalized with the low-pass filtered (smoothed) NIR channel image, used as a map of illumination intensity in the image field. The NIR-smoothed normalization is used to compensate heterogeneities in illumination (shadows, leaves in different canopy layers etc.). After these intensity normalizations, the distribution of raw values of grey levels in the three channels did not allow a clear discrimination between healthy and diseased areas. Nevertheless, this can be enhanced by using appropriate spectral indices, i.e. algebraic combinations of pixel's grey levels in two or more spectral channels. In particular, the following spectral indexes showed encouraging discrimination power on our training sets. For PM detection:

$$I1 = (\text{Red} * \text{Green}) / \text{NIR}^2 \quad [1]$$

$$I2 = (\text{NIR} - \text{Red}) / (\text{NIR} + \text{Red}) \quad [2]$$

and for DM detection:

$$I3 = \text{Red} / (\text{Red} + \text{Green} + \text{NIR}) \quad [3]$$

$$I4 = \text{Green} / (\text{Red} + \text{Green} + \text{NIR}) \quad [4]$$

The indexes are designed to respond differently to reflectance variations in either red or green channel, or a combination of both. Indeed, being the red channel overlapped to the chlorophyll absorption band, this is especially expected to respond to local tissue degradation linked to a pathogen attack, while the green channel is more associated to yellowing pigmentation, typical for DM and in general for more advanced diseases symptoms.

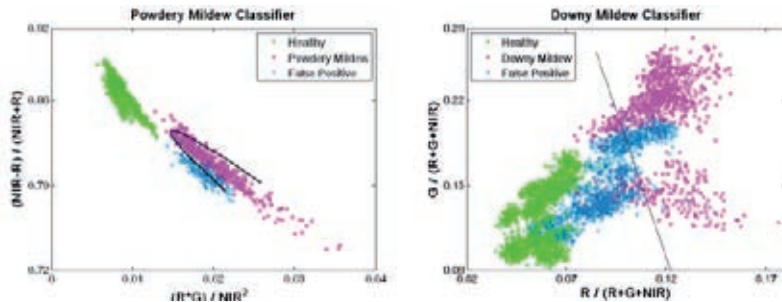

Fig. 2. Distribution of the indexes computed for the pixels from powdery mildew (left) and downy mildew (right) training sets. Data from healthy tissue is shown in green; abnormally illuminated or pigmented or young tissue is shown in blue, diseased tissue is shown in magenta. Solid lines represents the discriminating the function used as classifiers.

Figure 2 shows how pixels from ROIs of the training set are mapped into the plane defined by the spectral indexes pairs respectively for PM (Fig.2, left) and DM (Fig.2, right). The data corresponding to healthy and diseased tissue appear to be gathered enough for effective clustering of both the diseases. It is nevertheless evident the possible misclassification problems that pixels from non-uniformly illuminated areas or from very young leaf tissue (here classified as false positives) can lead to.

For PM case, in the spectral indexes plane, the plume-shape distributed disease data were discriminated from healthy and false positives by means of a quadratic function; while for more sparse data of DM case, a linear function was chosen. The classification indexes and their corresponding discriminant functions were implemented in image analysis disease detection algorithm. After background removal, for each foreground pixel the indexes I1 and I2 (for PM images) or I3 and 4 (for DM images) are computed, and according the discriminant function the pixel correspondingly classified. As result a set of binary regions are obtained as disease tissue candidates. Spurious isolated pixels are filtered by a morphological opening.



Regions left are then assumed as disease tissue, while the rest of the foreground is assumed to correspond to healthy tissue.

### 3. Results

Figure 3 shows two results examples obtained by applying the detection algorithm to two field images from PM and DM sets, respectively. The proposed classifiers appeared to fairly detect medium to advanced intensity symptoms for both the considered diseases, which can be considered a successful starting point for the multispectral adopted approach. Nevertheless, the misclassification problems created by false positives appear to be quite important and further hardware improvements are needed to reduce the influence of illumination homogenization and local light reflections, which appear to be crucial especially when working on young leaves. Classification robustness reinforcement is also expected by the adoption of a data-fusion approach, able to simultaneously consider images from multi-spectral and hyper-spectral cameras.

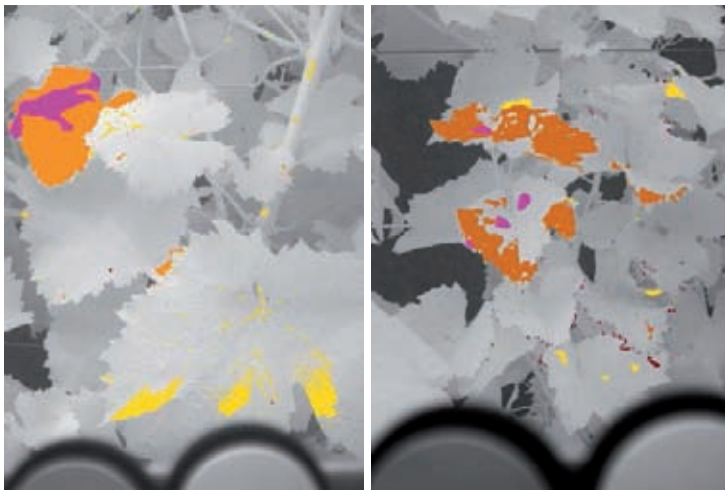

Fig. 3. Classification results of the disease detection algorithm on field images of grapevine canopy locally exhibiting powdery mildew (left) and downy mildew (right) symptoms. Uncolored regions represent healthy tissue correctly classified. Regions in orange indicate correctly detected diseased tissue, while in magenta are undetected diseases spots. In yellow are false positives, i.e. healthy tissue misclassified as mildew

**Acknowledgements.** *CROPS (GA-246252) is funded by the European Commission under the 7th Framework Programme within the theme “Automation and robotics for sustainable crop and forestry management”*



TOPIC n° 1.3

Close range precision spraying airflow /plant interaction

**Aleš Malneršič<sup>1</sup>, Marko Hočevar<sup>1</sup>, Brane Širok<sup>1</sup>, Massimo  
Marchi<sup>2</sup>, Paolo Tirelli<sup>2</sup> and Roberto Oberti<sup>2</sup>**

<sup>1</sup> *University of Ljubljana, Faculty of Mechanical Engineering, Aškerčeva 6, 1000  
Ljubljana, Slovenia, (e-mail: ales.malnersic@fs.uni-lj.si)*

<sup>2</sup> *Instituto di Ingegneria Agraria (IIA), University of Milano (UniMI-IIA), via Celoria  
2, 20133 Milano, Italia, (e-mail: roberto.oberti@unimi.it)*

**Keywords:** precision spraying, air assisted spraying, plant interaction, plant oscillations

---

**Abstract:** Most plant diseases develop at initial stage of infection around discrete foci, the primary source of new inoculum for widespread of diseases. We present a design and application of a close range precision spraying end effector, which was developed within CROPS EU project. Aerodynamic study of airflow / plant interaction was performed. The main goal was to establish favorable flow conditions around leaves for good pesticide application on both adaxial and abaxial leaves surfaces. In comparison with conventional spraying, coherent structures with close range precision spraying are too small to effectively carry spraying droplets around plant leaves and spray adaxial sides of leaves. We have used two close range precision spraying end effectors, rotated such that they both pointed the same spraying target. Flow fluctuations were introduced in the spraying airflow by a rotating screen.

---

## 1. Introduction

Precise application of pesticides supported by up-to-date technologies of target application is one of the most promising options of pesticide quantity reduction. The concept of precise application of pesticides involves adjustment of chemical



application to the needs of the target. Hence, there is a need to develop and introduce new techniques and systems for disease detection and pesticide application able to optimize the distribution of pesticides according to the specific characteristics of the target, such as disease's susceptibility, or the presence of infection symptoms.

## 2. Flow aerodynamics around plants and leaves

Fluid flow carries pesticide droplets and exhibits pressure forces to surfaces of leaves and branches. Flow field of fluids around deformable bodies such as plants and their interaction with fluid flow are very complex and challenging problem in mechanics of fluids (Delele et al., 2007; Endalew et al., 2010). Studies of aerodynamic properties inside canopies have been initiated by studies of drag properties of plants. Reviews of the turbulence structure above and within the canopy were presented by Raupach et al. (1991) and Finnigan (2000). Canopy turbulence is dominated by intermittent coherent structures that are responsible for most of the momentum and scalar fluxes, and whose length scales are of the order of the canopy height. Large coherent structures, enable good propagation and interaction with the plant. To some extent, large coherent structures are responsible for flux of pesticide droplets to adaxial sides of leaves. In comparison with conventional spraying, coherent structures formed by SEF are too small to effectively carry spraying droplets around plant leaves and spray adaxial sides of leaves. Another option for spraying of adaxial side of leaf is to include fluctuations in the spraying airflow. Fluctuations of the spraying airflow cause non-uniform pressure loading and movement of the plant.

## 3. Spraying end effector (SEF)

The spraying end effector (SEF) was designed with the aim to perform precision spraying of small patches of infected areas. SEF consists of the following components: airflow generator, airflow nozzle, pesticide nozzle with anti-dripping device, pump for pesticide, electrical connections (power supply and control signals), pesticide connection, and chassis with optional



electronics. The SEF provides narrow spray angle around  $30^\circ$  and  $150\ \mu\text{m}$  droplets size. SEF includes a two stage axial fan with counter rotating rotors.



Fig. 1. Close range precision spraying end effector (SEF). Left: back view of the model, middle: front view of the model and right: manufactured SEF with control box.

#### 4. Measurement setup

Measurements of plant/airflow interaction were performed according to setup shown in Fig. 2. One or two SEF were used with or without rotating airflow screen to introduce periodic fluctuations. We used a ficus pot plant with height 70 cm.

Plant movements were recorded by a fast camera and later analyzed by image analysis algorithm. The camera used for image acquisition was B&W FASTEC HISPEC 4. Camera operated at resolution  $640 \times 600$  pixel, 200 Hz frame rate and exposure time  $50\text{--}600\ \mu\text{s}$ , number of images acquired was 5000. Nikkor 50 mm F1:1.2 lens was used. Illumination was provided by eight LED lights CREE XM-L T5. Image analysis was performed on recorded images to measure displacements and velocities of leaves. First multi-parameter detection of plant was performed to separate plant from the background. Edge detection was performed using Sobel filtering method followed by outlying particle removal using erosion algorithm. For erosion all objects in image were kept, that were resistant to the specified number of erosions. Kept objects were rendered to the shape and size the same as before erosion algorithm. After particle removal algorithm, holes were filled. In the second step, in locations of the plant, velocity was estimated from two successive images using normalized cross correlation method.



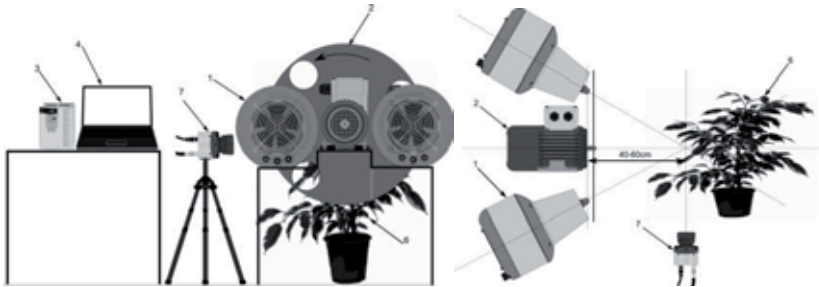

Fig. 2: Measurement setup: 1) SEF, 2) rotating airflow screen with four holes, driven by electric motor, 3) electric motor variable drive, 4) PC, 6) ficus plant, 7) high speed camera.

## 5. Results

Results show leaves displacements during spraying, influence of periodic excitation, influence of spraying distance and influence of frequency of periodic excitation on SEF performance. Leaves displacements are shown in Fig. 3 as a RMS value.

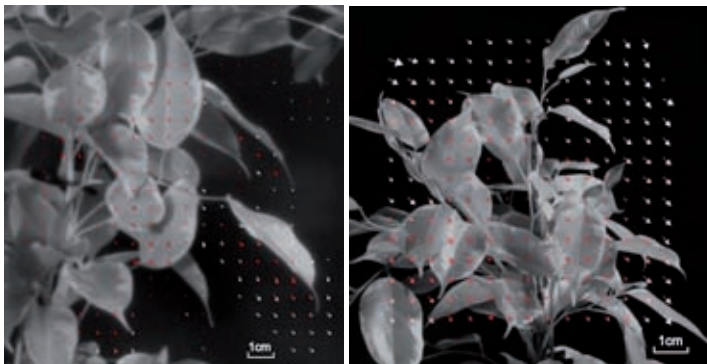

Fig. 3: RMS value of leaves displacements at distance 0.4m, left: without excitation, right: with excitation, screen rotational frequency is 1 /s.

Influence of periodic excitation is shown in Fig. 4. Fig. 4 left shows behaviour of plant without periodic excitation and Fig. 4 right with periodic excitation. Case with periodic excitations relates to the case with rotating screen and case without periodic excitations relates to case without rotating screen, that is continuous operation of SEF.

Without periodic excitation amplitudes of leaves displacements are low. With excitation, peaks of plant oscillations are around 10x higher and located at narrow frequency bands. Two SEF with excitation produce more peaks of fluctuations.

Influence of spraying distance for the case with excitation is shown in Fig. 4 right (0.4 m) and Fig. 5 left (0.6 m). Intensity of leaves fluctuations is reduced for about 2x.

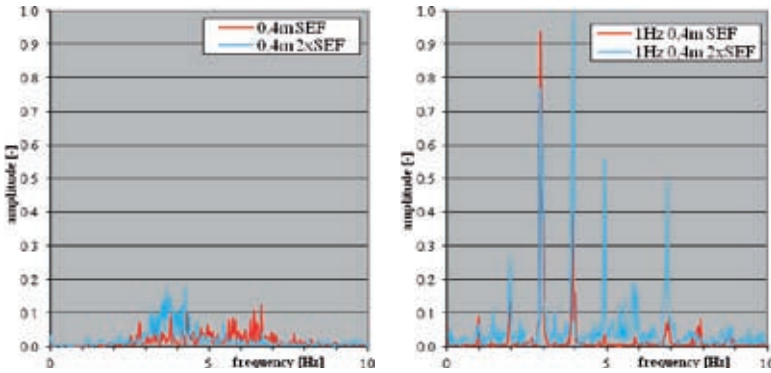

Fig. 4: Spectra of plant leaves displacements at distance 0.4 m, left: without excitation, right: with excitation, screen rotational frequency is 1 /s.

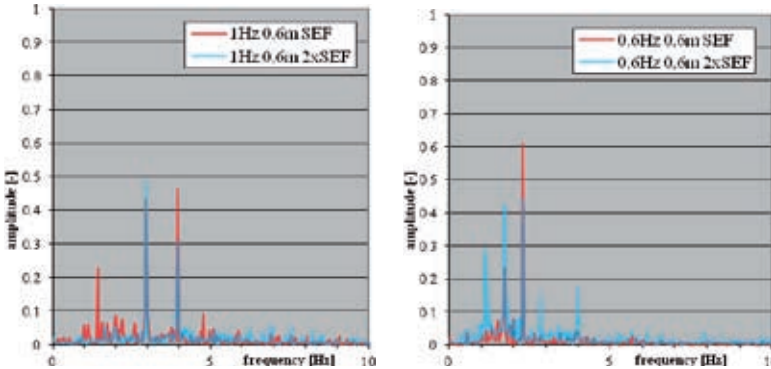

Fig. 5: Spectra of influence of distance and rotation speed on leaves displacements, left: screen rotation 1/s, right: screen rotation 0.6 /s.

To study influence of frequency of airflow fluctuations on leaves fluctuations, we varied rotational speed of the screen.



Influence of frequency of airflow fluctuations is shown in Fig. 5. Reduction of screen rotational speed causes frequency of leaves fluctuations to shift to lower frequencies.

## 6. Conclusions

We present close range precision spraying with SEF. For experiment, a spraying end effector was build and equipped with rotating airflow screen, which induced discrete frequency peaks of velocity fluctuations. Measurement of displacement of leaves in the airflow have shown that leaves fluctuate with discrete frequencies. For actual spraying application, the rotating airflow screen should be replaced with more compact device.

## Acknowledgements

*This work was funded by the European Commission in the 7th Framework Programme (CROPS GA no 246252).*

## References

- Delele, M.A., Jaeken, P., Debaer, C., Baetens, K., Endalew, A.M., Ramon, H., Nicolai B.M, and Verboven, P., CFD prototyping of an air-assisted orchard sprayer aimed at drift reduction. *Comp. elect. Agric.* 55 (1), 16–27, 2007.
- Endalew, A.M., Debaer, C., Rutten, N., Vercammen, J., Delele, M.A., Ramon, H., Nicolai, B.M. and Verboven P., Modelling the effect of tree foliage on sprayer airflow in orchards. *Boundary-layer Meteorol.* 138, 139-162, 2010.
- Raupach M.R., Antonia R.A., Rajagopalan S., Rough-wall turbulent boundary layers, *Appl. Mech. Rev.* 44:1–25, 1991.
- Finnigan, J., Turbulence in Plant Canopies, *Annual Review of Fluid Mechanics* Vol. 32: 519-571, 2000.



**First RHEA International Conference on  
Robotics and associated High-technologies  
and Equipment for Agriculture**  
Hosted by the University of Pisa  
Pisa, Italy, September 19-20-21, 2012



**TOPIC n° 1.3**

**RHEA airblast sprayer: studies on intermittent flow rate  
nozzle for VRT**

**Rimediotti, M.<sup>1</sup>, Sarri, D.<sup>1</sup>, Lisci, R.<sup>1</sup>, Vieri, M.<sup>1</sup>**

*<sup>1</sup> Dept. of Economics, Engineering, Science and Technologies in Agriculture and Forestry - University of Florence (Italy)*

**Keywords:** Pesticides application, intermittent sprayer, variable rate applications

---

**Abstract:** Current commercially technologies for the pesticides management are designed in many configurations, allowing a wide range of regulation, which however must be accompanied by technical and operational skills of the user. This condition introduces variable risks in relation to the proper configuration of the spray machine and the correct operating set-up and procedure. These aspects may be solved today by the introduction of sensor systems and operational monitoring tools to assist the operator work. In the project RHEA (robot fleets for highly effective agriculture and forestry management), the Florence O. U. has the aim to develop a sprayer prototype for the tree crops treatments to manage in real time, the quality and quantity of the pesticide mixture distributed and the intensity and direction of the air, depending on the structural variability of the canopy. For the variable rate application of dose in accordance with the canopy thickness it has been developed and tested the concept of pulsating flow rate technique that controls each nozzle in an independent way. To obtain an intermittence flow rate is applied, on the nozzles, an high frequency solenoid valve (HSFV) with the purpose of interrupting the pesticide flow rate. This is adjusted by acting on two parameters of the HSFV: frequency and duty cycle. The obtained data were processed and evaluated to verify the spray cloud features varying frequency and duty cycle adopted. Variation in terms of flow rate and of the droplets diameter were analyzed. In this preliminary study,



significant results were obtained by adopting frequency of 8Hz and 10Hz with reductions of the flow rate respectively of 44%, with 30% duty cycle and 25%, with 50% duty cycle, obtaining the same amount of the flow reduction independently of the type nozzle used.

---

## **1. Introduction**

The new trend in reduction of the pesticides dose, while also ensuring the effectiveness of treatments, needs to gain new technical knowledge and development of new pesticides sprayers, to ensure precise and safe treatments. The reduction of the doses does not mean the decrease of the unit dose on the parts to be protected, but the reduction of losses and dispersions that occur during the treatments operations (a part of the mixture is uselessly superposed on the previous, a part is lost on the ground and another is wasted for drift).

Recently, technologies that adapt the spraying to the canopy geometry and to the target characteristics, have reached an high development, allowing to eliminate loss to the ground and to improve the vegetation cover. This was possible, also, by adopting automatic devices able to use relief sensors, by computer analysis and actuators that can adapt the sprayer configuration to different conditions of use.

The control on the precision treatment is therefore an economic and productive objective, since that are required quality production, healthy and low cost. Accordingly it is conceivable to assume a technology development that will permit the realization of more efficient tools, which will allow further to reduce the environmental impact of agricultural production. In this context, the European project RHEA (Highly Effective Robot Fleets for Agriculture and forestry management) plans to create three autonomous vehicles that interact with each other and with the operator, working in fleets and operating in three specific contexts and cultures: wheat, corn and olives.

The main advances in the future spraying technology, will affect the design of vehicles that allow to adapt the spray only to the target vegetation. This will be done using a sensors system that detect height, shape and density of the canopy and regulate both

the jet of air and the size of the droplets and so, the quantity of mixture.

Many research has been conducted in order to obtain a variable flow rate control to adjust the dose to the canopy thickness. A solution that has been planned by the UO of Florence, in the project Rhea, is a device able to control the frequency and the duty cycle of a solenoid valve for the generation of an intermittent spray nozzle.

The pulsating spraying technique or intermittent jet has been developed by Falchieri et. Al. in 2008, with the aim of optimizing the activity of pesticides, exploiting the phenomenon of the active substance diffusion in the leaf cuticle. The system is based on the nozzles flow rate interruption with small time intervals.

The pulsating spraying technique combined with width pulse modulation was also recently adopted and studied by other researchers, such as these of Escolà et al., 2007, Hočevár et al. 2009, Chen, 2010.

The Modulated Spraying Nozzle-Control systems (MSNC), allow to perform variable rate treatments controlling the drift of the spray jet in a wide range of operating conditions. The system MSNC check the timing and duration of the pesticide spray from the nozzles.

## **2. Materials and methods**

The intermittent spray system test was conducted with three different nozzles Albuz ATR 80, color code: PURPLE, BROWN and YELLOW and a pump Annovi Reverberi AR-19 model. Each of the three nozzles worked at two different pressures: 0,5 and 1,0 MPa. Before the nozzles in the pipe were positioned the solenoid valves to obtain the pulsed jet. The high frequency solenoid valve (HSFV) worked in the following conditions:

- Frequency: 3Hz, 5Hz, 8Hz, 10Hz.
- Duty cycle: 20%, 30%, 50%, 75%



The solenoid valve used is the model ZB16 Parker that works at a maximum pressure of 1,0 MPa. To check if the solenoid functional parameters were properly adjusted (frequency and duty cycle) was used a 4-channel digital oscilloscope 100MHz HP. All the measurements were achieved by measuring the spray nozzles flow rate for one minute, the liquid delivered was collected in the graduated cylinder and subsequently weighed with the load cell. All the measurements, including those about the verification of nozzles operation, were performed in three repetitions in order to reduce the variability of sampling (72 measurements for each nozzle).

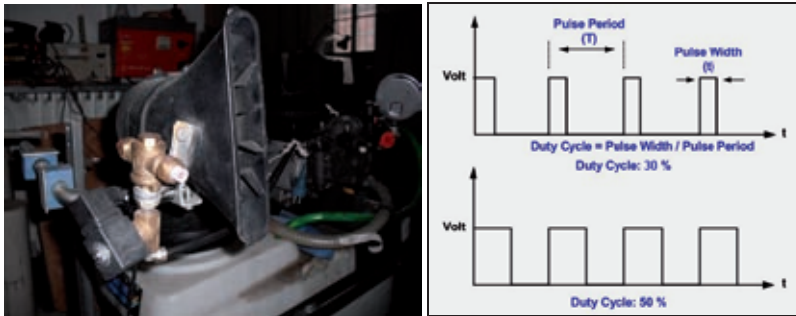

Fig. 1 - The solenoid valves to obtain a pulsed jet (left) and the HFSV operative scheme (right).

### 3. Results and first conclusions

The preliminary results of the research, highlights the possibility to vary, in real time, the nozzles flow rate, without changing other spraying parameters. In this study case, significant results were obtained by adopting frequency of 8Hz and 10Hz with mean reductions of flow rate (44%, with 30% duty cycle), and (25%, with 50% duty cycle), obtaining the same amount of flow



rates reduction for all types of nozzle.

Were discarded, however, the results obtained with the lowest frequencies (3Hz and 5Hz), in fact, under these conditions, we have obtained flow values completely different from those expected. It is assumed, that the phenomenon is due to interference with the pulsation of the pump that resonates with the solenoid valve.

Therefore, on the basis of this preliminary results, it was assumed that the system was working exclusively at frequencies higher than 5 Hz. The values obtained with 20% and 75% duty cycle were discarded, because they did not reduce significantly the flow rate.

Another important aspect, that emerged during the preliminary laboratory tests, it has been the localization point of the solenoid valve. In fact, significant results are obtained only when the valve is placed in correspondence of the nozzles, since placements distant from the nozzle, determines significant loss of flow energy and, consequently, flow rates fluctuations.

These preliminary studies will be completed with further survey about spray cloud features in the different duty cycle and frequency condition to get technical information on the pulsed-jet spray system, which, seems to be an interesting possibility to vary in real time the flow rate to the nozzles, in order to develop new systems for variable rate spraying.

Many are the bibliographic scientific references and many are researchers to find innovative technological solutions to make variable-rate spraying, with the aim to get a proportional distribution of mixtures to the vegetation target characteristics.



Ugello GIALLO							
bar	Freq. (Hz)	D cycle (%)	misura (l/m)			media	%
5	tabella albuZ 0,73		0,67	0,68	0,68	0,67	100
5	3	30	0,51	0,51	0,51	0,51	24
5	3	50	0,38	0,38	0,39	0,38	43
10	tabella albuZ 1,03		0,94	0,94	0,94	0,94	100
10	3	30	0,69	0,70	0,70	0,70	26
10	3	50	0,52	0,52	0,52	0,52	45
Ugello GIALLO							
bar	Freq. (Hz)	D cycle (%)	misura (l/m)			media	%
5	tabella albuZ 0,73		0,67	0,68	0,68	0,67	100
5	5	30	0,55	0,56	0,56	0,56	18
5	5	50	0,42	0,44	0,42	0,43	37
10	tabella albuZ 1,03		0,94	0,94	0,94	0,94	100
10	5	30	0,75	0,74	0,74	0,74	20
10	5	50	0,56	0,55	0,56	0,56	41
Ugello GIALLO							
bar	Freq. (Hz)	D cycle (%)	misura (l/m)			media	%
5	tabella albuZ 0,73		0,67	0,66	0,66	0,66	100
5	8	30	0,34	0,34	0,33	0,33	49
5	8	50	0,45	0,46	0,46	0,46	31
10	tabella albuZ 1,03		0,94	0,94	0,94	0,94	100
10	8	30	0,45	0,46	0,45	0,45	52
10	8	50	0,64	0,64	0,63	0,64	32
Ugello GIALLO							
bar	Freq. (Hz)	D cycle (%)	misura (l/m)			media	%
5	tabella albuZ 0,73		0,67	0,66	0,66	0,66	100
5	10	30	0,40	0,39	0,39	0,39	41
5	10	50	0,52	0,51	0,51	0,51	22
10	tabella albuZ 1,03		0,94	0,94	0,94	0,94	100
10	10	30	0,48	0,50	0,49	0,49	48
10	10	50	0,64	0,66	0,66	0,65	30

Tab. 1 – Preview of the achieved results.

## References

- Chen, Y. (2010) Development of an intelligent sprayer to optimize pesticide applications in nurseries and orchards , unpublished Ph.D. Dissertation.
- Escolà, A., F., Camp, F., Solanelles, J., Llorens, S., Planas, J.R., Rosell, F., Gràcia, E., Gil & L. Val (2007) Variable dose rate sprayer prototype for dose adjustment in tree crops according to canopy characteristics measured with ultrasonic and laser lidar sensors, Atti del Convegno internazionale “ECPA-6th European Conference on Precision Agriculture”, pp. 563-571.
- Falchieri D., Lolli M., Romagnoli L, Vicini M., Brandi M., 2008. Una tecnica di applicazione a getto intermittente per trattamenti a dosi/ha fortemente ridotte: risultati nel diserbo di grano e sorgo e nella difesa antiperonosporica della vite. Atti Giornate Fitopatologiche, 2, 65-72
- Grisso R., Alley M., Thomason W., Holshouser D., Roberson G. T., (2011), Precision farming tools: variable-rate application., Virginia Cooperative Extension.
- Hočevar, M. et al. (2009) Design and testing of an automated system for targeted spraying in orchards, Journal of Plant Diseases and Protection, 117 (2), 71 79.



**TOPIC n° 1.3**

**The RHEA airblast sprayer: studies on a continuous mixer  
for the VRA**

**Sarri, D.<sup>1</sup>, Lisci, R.<sup>1</sup>, Rimediotti, M.<sup>1</sup>, Vieri, M.<sup>1</sup>**

<sup>1</sup> *Dept. of Economics, Engineering, Science and Technologies in Agriculture and  
Forestry - University of Florence (Italy)*

**Keywords:** Pesticides mixing, dosage group, reduction risk  
operator

---

**Abstract:** The agrochemical dispersion may affect the environmental compartments such as: air, water, soil, due to surface runoff phenomena, leaching, volatilization, degradation and adsorption of pesticides in the soil. These processes involve health risks for workers, for all those that living near agricultural areas and, of course, are causes to environmental contamination. The increasing attention of public institution to the promotion of production processes at low environmental impact, it's progressively influencing the implementation of new devices to minimize the environment pesticides losses and the risks for the operators. The objective of this study, concerns the possibility of realization of a device prototype for the instant mixing of pesticides during application phase, with particular reference to the correct dose of distribution, the homogeneity of the mixture, the savings in pesticide quantity and the operator safety involved in the mixing. The use of this technology, combined with the other tools already available for the VRA pesticide application, represents an evolution in the control of the agriculture pesticide problems, in agreement with the new European laws.



## 1. Introduction

The application of plant protection products has an important role in agricultural production processes. With current pesticides management, a huge amount of them are applied to worldwide orchards. The pesticides use imply some negative consequence: increase production cost thus limiting a company's profitability, reduction of food quality and creation of potential environmental contamination, also exposure of the operators to the chemical risk. On the other hand, the current economic structure of rural society do not permit losses in yield and in the quality of crops due to pests.

These conditions require to find solutions aimed to realize both an eco-friendly environmental management and the reduction of drift, leaching and the related risks.

Current pesticides application operative procedures involve a discontinuous stages of pesticides mixtures preparation developed at the farm center; one or more qualified workers that provides to refill the sprayer and cleaning of all devices.

The second phase occurs normally many time for each treatment. This type of management and logistics introduces potential risks of contamination of workers and environmental more in case of accidental spillage during transfers.

A different problem is the limited timeliness in the treatment period and so in the phase of mixture preparation depending on the types of orchard, training systems and used products (pesticides and/or foliar fertilizers).

But the problem of modulate mixture preparation it is essential in the variable rate application (VRA) on which it is not possible to know how many mix may be necessary in the field; a precise application depends on the canopy density and characteristic and this it is variable in function of canopy type, season trend, soil features, growth stage and crop management.

The main focus of this investigation was on assessing the feasibility of continuous mixing and direct injection for pesticides and foliar fertilizer application using a system that could avoid mixing and delay time problem as in the realized injection systems.

## **2. Materials and methods**

The standard configuration of a sprayer includes a single main carrier tank with mixture storage function and other tanks such as these for clean water for operator safety and for washing. Other mixing auxiliary devices are today available to aid operator to better and in more safe way prepare the mix. Although the advantages achieved with the integration of them on sprayers, their diffusion is hindered by the need of more in the equipment and further costs.

Other technological gap, is the lack of devices able to handling in variable and continuous way the contemporary pre-mixing of liquid and solid pesticides. In fact, the only available system provide the use, only for the liquid products, of piston or peristaltic pumps that inject the product in the water delivery main line mainly at low pressure. For the powdery and granular pesticides there aren't currently available solutions. Today, these technologies allow us only to manage the flow pump/s but do not allow proper formulations mixing. Moreover, in arboriculture and in the specific case of the orchard, are generally used many types of products for the pest control, characterized by different physical characteristics (liquid, powder, granular) usually at high concentration.

Therefore it could be hypothetical to develop a new "concept" with a different scheme of the sprayer plant with the introduction of a principal tank that it is not the bigger that has the function of the current standard one and more it is refilled in continuous by water and chemicals.

For the development of the pesticide instant mixing device, it was hypothesized a new sprayer architecture, as in figure 1, characterized by additional dosage group with respect to the conventional airblast sprayer.

This dosage device it is composed by auxiliary rechargeable or replaceable tanks for liquid and solid formulations and a correspondent set of peristaltic pumps for liquid formulate and a cochlea od lamellae system for dust or granule.



**Current configuration of air blast sprayer**

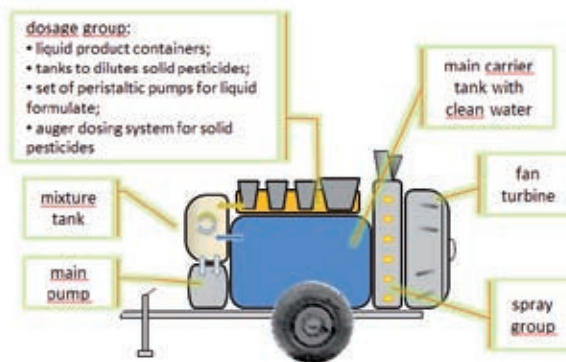

**Hypothesis of new architecture of air blast sprayer**

Figure 1: new concept air blast sprayer

The interchangeability of the commercial preparation containers, already available in some Countries as USA, is an essential feature to allow widest employ versatility, the variation of the number and capacity installable tanks to differentiate and accommodate the variation requests in different phenological stages and crops. The possibility of removable tanks increase the safety for the workers due to the minimal exposure to chemicals and potential risks in the refilling phases from the packaging inside the sprayer.

All complementary tanks used, should have a trapezoidal shape to avoid air intake when the mixture and the protection product reach the minimum level.

System architecture includes a control unit installed on board the tractor that allows to set the volume that must be distributed, the

type and the number of commercial products necessary for the treatment. The products and the water, by means of peristaltic pumps and the other system for dust, running in phase, are charged inside the mixing main tank that ought have a capacity of few tens litre (40-50 L). Here the commercial preparations are mixed by turbulent mixing due to the main pump like in the conventional sprayer and with a flow rate that it is very much greater. The refilling could be continuous or discontinuous: in this second case during the spraying progressively the mixture level in the tank decreases up to a minimum (e.g. 15 L) monitored by a level sensor: at this moment, the level sensor generates a signal which acts simultaneously the battery of dosing pumps and systems bringing again the level to established level in the mixing main tank (e.g. 40 L).

The use of turbulent mixing device ensures a quickly and efficient mixing, consequently a continuity of the system by solving critical which would result at the time that mixture runs out in the dosage group and began again the preparation process. These would results in an inconsistency of the mixture ratio of commercial products .

### **3. Consideration**

The concept of the pesticides instant mixing device allows the operator to work in high safety conditions, reducing the contact risks from the active substances during the auxiliary phase and, simultaneously, eliminating the possibility of error during the calculation of doses to be used at each refuelling sprayer. Electronic auxiliary systems, might be able to store various phenology application programs, automatically setting the dosages of pesticides used and leaving to the operator only the supply of water in the sprayer, ensuring the maximum efficiency.

The advantages of a continuous mixer with direct chemical injection systems are:

- main carrier tank is loaded with clean water, not mixed with chemicals;
- concentrated liquids and solid chemicals are accurately stored in a safe way and used when and if necessary:





unused concentrated chemical remains safe and secure in a dedicated holding tank.

- operator exposure to chemical concentrates it is reduced;
- there is no pre-mixing of chemicals in the main carrier tank with reduced spillage risk;
- there is no or limited amount of mixed product at the end of the treatment also in the VRA spraying operations;
- The operator can quickly change from one chemical product to another without cleaning and rinsing the main carrier tank.
- chemicals use and concentration could be varied in accordance with prescription maps.

This concept offers an opportunity to reduce potential risks of contamination of workers and environmental and also, introduce a potential efficiency improvement in the use of pesticides.

## References

- Ess D., R., Parsons S., D., Medlin C., (2001), Implementing site-specific management: sprayer technology – controlling application rate and droplet size distribution on the go., Purdue University, Purdue Extension.
- Gillis K. P., Giles D. K., Slaughter D. C., Downey D., (2003), Injection mixing system for boomless, target-activated herbicide spraying, American Society of Agricultural Engineers, Vol. 46(4): 997–1008.
- Gil E., Escola A., Rosell J.R., Planas S., Val L. (2007), Variable rate application of plant protection products in vineyard using ultrasonic sensors, Crop Protection 26, 1287–1297
- Hlobe P., doctoral thesis, (2007),“Study on the response time of direct injection systems for variable rate application of herbicides. Rheinische Friedrich-Wilhelms-Universität Bonn, Germany Institute of Agriculture Engineering.
- Humburg D.,(2001), Variable Rate Equipment—Technology for Weed Control, Site-Specific Management Guidelines, published by the Potash & Phosphate Institute (PPI).
- Grisso R., Alley M., Thomason W., Holshouser D., Roberson G. T., (2011), Precision farming tools: variable-rate application., Virginia Cooperative Extension.
- Nolte K. D., Siemens M. C., Andrade-Sanchez P. (2011), integrating variable rate technologies for soil-applied herbicides in arizona. University of Arizona, College of Agriculture and Life Sciences. [HTTP://cals.arizona.edu/pubs/crops/az1538.pdf](http://cals.arizona.edu/pubs/crops/az1538.pdf).
- Qiu W., Watkins G. A., Sobolik C. J., Shearer S. A.,(1998) A feasibility study of direct injection for variable-rate herbicide application, American Society of Agricultural Engineers, Vol. 41(2):291-299
- Rashidi M., Mohammadzamani D., (2011), Variable rate herbicide application using gps and generating a digital management map., Herbicides, theory and applications, 127-144, ISBN 978-953-307-975-2, Intech.
- Vieri, M., Spugnoli, P. (1997) A high pressure injection system for precision application of pesticide, Precision agriculture, Volume II, John V. Stafford Editor, SCI Bios Scientific Publishers.



**Theme 2**  
Automation and robotics  
for precision agriculture







**First RHEA International Conference on  
Robotics and associated High-technologies  
and Equipment for Agriculture**  
Hosted by the University of Pisa  
Pisa, Italy, September 19-20-21, 2012



## **Automation and Robotics for precision agriculture: state of the art and perspectives**

**Paolo Gay**

*Università degli Studi di Torino, Dipartimento di Economia e Ingegneria Agraria  
Forestale e Ambientale, via Leonardo da Vinci 44 10095 Grugliasco (TO) – Italy (e-  
mail: paolo.gay@unito.it)*

**Keywords:** Robotics for agriculture, automation, protected  
crops

---

### **Abstract:**

Robotics and automation (R&A) in agriculture and, particularly, in high profit crops, mainly consist in ad-hoc machines able to perform one specific operation (sowing, transplanting etc.) obtaining high performances in terms of speed and work accuracy.

However, in some specific contexts such as e.g. greenhouse productions, available tools are not sufficient to fulfil the demand of specialized machines where there is still a strong need of high level of automation machines that could move and operate autonomously in the production site. To cope with this request, recent researches are devoted to the development of autonomous robots modules able to perform a number of different tasks. In particular, autonomous robots could be adopted for localized high precision chemical applications, as well as to perform other operations such as products handling, mechanical weed control, precision fertilization and cutting.

Aim of this paper is to discuss, also on the base of the recent results appeared in literature, future trends and application of robotics in protected crops.



## **1. Introduction**

Robotics and automation are widely diffused in many industrial and production sectors. At present, agriculture has been only partially involved in this process. The reasons of the delay in the technological transfer of R&A towards agriculture and, in particular, protected crops have been thoroughly analyzed in Kassler (2001) and Belforte et al. (2006).

Despite that, many researches have been conducted to develop reliable technologies, based on ICT, R&A, artificial vision and intelligence, and prototypes for agricultural applications. More than twenty years have been passed since the publication of the first results and until now many hundreds of papers have been published. Different approaches and prototypes typologies have been presented and some of them have been successively revised and improved.

Scope of this paper is to outline a general framework of the state of the art and to summarize those solutions that turn out to be the most promising. In particular, this study has been focused on robots and high-level of automation machines that can autonomously perform operations on crops. The general features of prototypes and robotics systems proposed in this analysis have been grouped according to four main headings: the operative environment (greenhouse or open field), the typology of the solution (autonomous robots, guided navigation robotic platforms, fixed point cells and tractor implements), the performed operation on the crop, the navigation and control strategies.

## **2. Operative environment**

R&A solutions can be firstly classified considering the operative destination of the machine, i.e. if the applications are in open field or in protected crops, mainly in greenhouses. Although many operations are performed in both environments, some important factors influence the design strategies and the reliability of the machines, in particular for what concerns the

displacement of the robot or, in the advanced applications, the autonomous navigation.

Most part of research contributions is for the open field, with particular emphasis to automatic guided machines. Open field is strongly unstructured, without fixed reference points, subject to variable climate and, often, presents severe conditions (humidity, powder...) for robots. The navigation on tilled soil requires power for the traction. For this reason this kind of machines are heavier than the same for greenhouses of nurseries. In this context, many studies concern robotic weeding in organic farming, where the employment of herbicides is not allowed (see e.g. Sørensen et al. 2005). Greenhouses have a higher predisposition to the introduction of robotic systems than the open field, for a number of technical and economical reasons (Belforte et al., 2006; Belforte et al., 2007; Sandini et al. 1990). Crops are intensively cultivated following regular schemes, in the presence of infrastructures, on regular surfaces and taking advantage of facilities (power supply, irrigation plants, pressured air...). In addition, greenhouses are typically equipped by climate, lighting and irrigation control systems that make environment condition more controlled than in open field. Finally, the intensive production of high value crops justifies the investments needed for the introduction of new technologies.

### **3. Structure of the machine**

A first classification within this heading can be made between stand-alone robotic platforms (fixed or mobile) and tractor implement. In the latter case, studies concern the development of “intelligent” implements as, for example, the automatic driving of steerage hoes for mechanical inter-row weed control (Tillet et al., 2002; Tillet and Hague, 1999), or different intra-row weeding implements (Nørremark et al., 2008; Tillet et al. 2008; Blasco et al., 2002). Other kind of automated implements can be found in Bulanon and Katoaka (2010), and in Leemans and Destain (2007) where robotic harvesting of apples and precision seed drill guidance are presented, respectively.





Among robotic platforms, many studies were focused on mobile autonomous vehicles able to follow crop rows. Most of them have been conceived to operate in open field for weeding or distribution of chemicals on crops. Only few examples have been specifically developed for greenhouse applications (Balloni et al., 2008; Sandini et al., 1990). With regard to the motion system, wheels have been preferred to tracks, which have been employed only in Chatzimichali et al. (2009), Belloni et al. (2008) and Hayashi et al (2009). Although a better traction and a less soil compaction, tracks suffer steering operations in narrow spaces (Bakker et al., 2010). Four driving and steering wheels give a high manoeuvrability to the vehicles both along crops rows and in headlands respect to other solutions, thus this travelling gear is adopted in more recent autonomous robots (Bakker et al., 2010; Comba et al., 2012a and 2012b; Sørensen et al., 2010 and 2007; Slaughter et al., 2008; Bak and Jakobsen, 2004).

Robotic cells that operate at fixed point or that are moved by a fixed navigation system (e.g. rails on the ground or monorail suspended from the ceiling) are typically employed in greenhouses. In the first case the product is provided to robotic station by conveyor belts or mobile benches (Rath and Kawollek, 2009; Belforte et al., 2006; Cho et al, 2002; Reed et al., 2001; Ryu et al, 2001), whereas in the second case the robotic cell moves on fixed path along crops rows. Rails are the most frequent solution to displace robotic stations through the greenhouse. They can be installed on floor (Hayashi et al. 2009; Tanigaki et al, 2008), exploiting greenhouse structures as proposed by Belforte et al. (2007) or existing facilities (e.g. exploiting heating plant pipes as in Van Henten et al., 2003 and 2007).

Fixed point and fixed navigation systems avoid the autonomous navigation, which is technically quite complex, reducing costs and assigning all hardware and software resources to crop operations (Belforte et al., 2007). A number of high throughput fixed-point machine are already available on the market for



seeding, potting and transplanting in plant nurseries (see e.g. Urbinati, 2010).

#### **4. Operations on crops**

Weed control is the most studied operation that could be performed by agricultural robots. Robotic weeding is considered a valid solution to reduce the employment of herbicides in the next future, improving the sustainability of the agriculture (Slaughter et. al, 2008; Griepentrog et al., 2004).

A first solution to reduce the usage of herbicides is the precision spraying. This technique consists in the application of herbicides only in regions of the field in which a weed emergence occurs. Product distribution is typically performed using spraying bars equipped with valves driven by an artificial vision system, which identifies weed emergencies (Slaughter et. al, 2008). In some case the spraying operation is very precise, reaching the single leaf or the stem of the weed (Jeon and Tian, 2009; Søgaard and Lund, 2007).

More studies have been focused on physical weed control. Inter-row weeding can be improved introducing automation for driving conventional steerage hoes with an artificial vision system (Tillet et al., 2002; Tillet and Hague, 1999). Regarding to physical intra-row weed control numerous autonomous robots were developed. Besides the autonomous navigation along crops rows, the control unit of these robots have to identify and separate crops and weeds in order to remove each weed seedling with by a specific tool. Some examples of implementation of this kind of mechanical actuators for intra-row weeding are in Bakker et al. (2010), Sørensen et al. (2007), Åstrand and Baerveldt (2002), Lamm et al. (2002). Peruzzi et al. (2012) proposed a precise mechanical and thermal treatment that removes weeds from the inter-row crop space and applies in-row selective and precision flaming by means of two crossed LPG rod burners.



For the inactivation of the weed, Lee et al. (1999) proposed the employment of an air pressure jet, whereas Blasco et al. (2002) applied an electrical discharge. Jeon and Tian (2009) developed a direct chemical application end effector that cuts the stem of weeds and wipes chemical on its cut surface, promoting the penetration via the vascular tissue.

Distribution of chemicals for diseases control is a further important item in agriculture, in particular in protected crops, where the climatic conditions and the intensive practice impose several treatment cycles. In this case the main challenge is to avoid the presence human operators inside greenhouses during treatments using autonomous vehicles (Balloni et al., 2008; Mandow et al. 1996; Sandini et al., 1990) or fixed robotic cell in the case of pot crops (Belforte et al., 2006 and 2007). Robotic systems can also perform a precise application of chemicals reducing product leakages with significant economical and environmental advantages. In this case, an automatic crop recognition system is required (Belforte et al., 2006 and 2007; Tillet et al. 1998, Sandini et al., 1990).

Several studies have also been dedicated to the harvest of fruit, vegetables and flowers with the aim to reduce the labour requirement, especially when this operation is exclusively manually performed. Excluding a mobile robot for asparagus harvesting in open field proposed by Chatzimichali et al. (2009), two tractor implements developed by Bulanon and Kataoka (2010) and Peterson et al. (1999) for apples (De-An et al, 2011) and the oranges harvesting proposed by Muscato et al. (2005), harvesting robots developed so far have conceived to operate in greenhouse with highly structured growing schemes (Kondo et al. 1996 and 1999) adopting fixed point (Rath and Kawollek, 2009; Cho et al., 2002; Reed et al., 2002) or fixed navigation platforms (Hayashi et al. 2009; Tanigaki et al, 2008; Van Henten et al., 2003). Harvest is the most difficult crop operation since involves the direct interaction of the robot with extremely delicate targets (Hayashi et al. 2011). For this reason particular tools have been developed in order to manipulate the objects avoiding damaging them. Usually, these end-effectors consist of

two parts: a gripping mechanism, often in combination with a suction device, and a peduncle-cutting system that in most cases are a sort of shears, whereas Van Henten et al. (2003) propose a thermal cutting device for cucumber harvesting.

A feature that I consider fundamental is the ability to host different tools carrying out a number of tasks. It has to be noted that most agricultural robots are able to perform only a single specific operation. Belforte et al. (2006 and 2007) and Van Henten et al. (2003 and 2007) presented their prototypes as multipurpose robots. In the first case two different fixed-point robotic cells were equipped with a set of tools (precision spraying, precise grain fertilization, pot handling, mechanical weed control) operating on pot crops, whereas cucumber harvesting and de-leafing were performed in the second one.

## **5. Path planning and guidance control strategies**

Core technologies for agricultural robots implemented as autonomous vehicles are the localization and guidance systems. Among the number of guidance-sensing technologies investigated in last decades two type of sensors have achieved a commercial maturity: Global Position System (GPS) and machine vision (see e.g. Slaughter et al. 2008). These technologies were employed alone or together to increase the accuracy. The operating environment typically conditions the choice between the different systems. The employment of GPS based navigation systems is not recommended in protected crops, in particular in glasshouses, where the presence of metallic structures strongly attenuates the satellite signals. As an example, Søggaard and Lund (2007) developed an autonomous robot able to operate both in field and indoor, but GPS is activated only outdoor. In many cases, Dead Reckoning technique, i.e. the process of updating the current position using known or estimated speeds over elapsed time, is used to enhance GPS precision, especially in the case of short-time signal loss (Nagasaka, 2004). On the contrary, the performances and the robustness of machine vision based systems strongly depend on



light conditions (Slaughter et al., 2008), therefore particular row tracking algorithms have to be developed in particular for open field. To cope with this problem, some robots have been designed to work during the night, under artificial light conditions. Information provided by GPS and/or artificial vision were integrated with other sensors such as encoders installed on traction and steering system, electronic compass and accelerometers. Ultrasonic sensors were also considered to assist the autonomous guidance as proposed in Cho and Lee (2000), Harper and McKerrow (2001), and Mandow et al. (1996). In most cases these sensors are used to measure the lateral distance from crops and/or benches, allowing the machine to maintain a straight path (Hague et al, 2000). Comba et al (2012) proposed a navigation system, to be used in pot crop nurseries, which uses fixed ground references, such as ribbons, lied in the middle of the inter-rows. Among the different kinds of sensors that were tested (optical infrared, capacitive and inductive), the best performances were achieved employing proportional inductive sensors coupled with a metallic ribbon. This solution allows the farmer to plan the path in a very simple way, fixing the ribbon on the ground. At the same time the working area of the robot is known and bounded, which is an important issue for the safety of the operators.

With regard to control of tools, machine vision is widely employed since the spatial position of the operations targets (crops, weeds or parts of them) is generally unknown. When the contact with the target is foreseen, such as precision spraying, the same vision system adopted for autonomous navigation could be exploited (Tillet et al. 1998). Otherwise, for example in the case of GPS based mobile robots or robotic cells, tools are controlled by a proper artificial vision system. Many researches were focused on the development of algorithms able to separate the objects in different classes (crop, background, weed...). Even in this case, light conditions variability affects the artificial vision system performances, thus some authors adopted illumination systems, in combination with shields, in order to acquire images in standard light conditions. Åstrand and

Baerveldt (2002) and Lee et al. (1999) apply this technique for robotic weeding in open field.

Harvest needs more complex artificial vision systems, usually based on stereovision, because objects (fruits, vegetables or flowers) have to be identified and located in a three-dimensional space.

## **5. Conclusions and perspectives**

The introduction and diffusion of robotics systems will represent an important opportunity for agriculture in next future. The employment of robotic systems will improve sustainability and work safety in many agricultural sectors as well as a consistent production costs reduction. Distribution of chemicals by means autonomous robots would avoid the presence of human operator during treatments in particular in greenhouses where this operation is still manually performed. At the same time, a significant reduction of pollutants can be obtained with precise application of pesticides. Environmental friendly practises as physical weed control would become economically feasible with consistent costs depletion in particular in organic farming (Sørensen et al, 2005; Griepentrog et al., 2004). Pedersen et al. (2006) demonstrate the economical feasibility of applying autonomous robotic vehicles, compared to conventional systems, in micro-spray robotic weeding, crop scouting and grass cutting in golf courses. However some technical and economical challenges will have to be faced in next years to achieve a real diffusion of robotics in agricultural practices and its consequent benefits. The high costs and reliability of guidance systems as well as the small throughput are still an obstacle that increase the cost of robotic systems (Pedersen et al., 2006). Detection and identification of crops and/or weeds under a wide range conditions common to agricultural scenarios remains another important challenge (Slaughter et al., 2008).

In the author opinion there are some interesting perspectives in R&A for agriculture. First of all, the development of light robots, that could perform simple operations, using the simplest



possible technologies, without the presence of human operators. This kind of machines could be primarily devoted to spraying operations, but could also be used in other repetitive simple tasks. To reduce costs and complexity, these robots could be designed to use fixed references (laser pointers, straight magnetic or optical line etc.) for the navigation, favouring greenhouse applications. Furthermore, research efforts should be addressed to develop more flexible robots in terms of row distance and parcel size as well as of ability to host different tools. In this way the same robotic platform (fixed or mobile) could perform many operations on different crops, optimizing the costs.

## References

- Åstrand B, Baerveldt A J 2002. *An Agricultural Mobile Robot with vision-based perception for mechanical weed control*. *Autonomous Robots*, 13, 21-35
- Bak T, Jakobsen H 2004. *Agricultural robotic platform with four wheel steering for weed detection*. *Biosystems Engineering*, 87 (2), 125-136.
- Bakker T, van Asselt K, Bontsema J, Muller J, van Straten G 2010. *Systematic design of an autonomous platform for robotic weeding*. *Journal of Terramechanics*, 47, 63-73
- Balloni S, Caruso L, Conti A, Schillaci G, Longo D, Muscato G 2008. *Preliminary Study for the Development of an Electrical Autonomous Vehicle for Safe Agricultural Chemicals Distribution Inside Greenhouses*. *Int. Conf. "Innovation Technology to Empower Safety, Health and Welfare in Agriculture and Agro-food Systems"*, September 15-17, Ragusa, Italy
- Belforte G, Deboli R, Gay P, Piccarolo P, Ricauda Aimonino D 2006. *Robot Design and Testing for Greenhouse Applications*. *Biosystems Engineering*, 95, 309-321

- Belforte G, Gay P, Ricauda Aimonino D 2007. *Robotics for improving quality, safety and productivity in intensive agriculture: challenges and opportunities*, in Industrial Robotics: Programming, Simulation and Applications. Low Kin Huat, Advanced Robotic Systems, Vienna, Austria
- Blasco J, Alexios N, Roger J M, Rabatel G, Moltò E 2002. *Robotic weed control using machine vision*. Biosystems Engineering, 83, 149-157
- Bulanon D, Kataoka T 2010. *A Fruit Detection System and an End Effector for Robotic Harvesting of Fuji apples*. Agricultural Engineering International: The CIGR Journal, 12 (1), 203-210
- Chatzimichali A P, Georgilas I, Tourassis V 2009. *Design of an advanced prototype robot for white asparagus harvesting*. Int. Conf. on Advanced Intelligent Mechatronics, AIM 2009, Singapore, 14-17 July
- Cho S I, Lee J H 2000. *Autonomous Speedsprayer using Differential Global Positioning System, Genetic Algorithm and Fuzzy Control*. Journal of Agricultural Engineering Research, 76 (2), 111-119
- Cho S I, Chang S J, Kim Y Y, An K J 2002. *Development of a Three-degrees-of-freedom Robot for harvesting Lettuce using Machine Vision and Fuzzy logic Control*. Biosystems Engineering, 82 (2), 143-149
- Comba L, Gay P, Ricauda Aimonino D 2012. *Robotic solutions for pot-plant nurseries*, CIGR-EurAgEng 2012, Valencia (Spain), 9-12 July, paper number C2095.
- Comba L, Finez Martinez S, Gay P, Ricauda Aimonino D, *Reliable low cost sensors and systems for the navigation of autonomous robots in pot crop nurseries*, RHEA Conference, Pisa (Italy), 19-21 September 2012.
- De-An Z, Jidong L, Wei J, Ying Z, Yu C 2011. *Design and control of an apple harvesting robot*. Biosystems Engineering, 110(2), 112-122
- Griepentrog H, Christensen S, Søgaard H 2004. *Robotic weeding*. Proc. of EurAgEng04 - Leuven, Belgium, 12-14 September





- Hague T, Marchant J A, Tillet N D 2000. *Ground based sensing system for autonomous agricultural vehicles*. Computers and Electronics in Agriculture, 25, 11-28
- Harper N, McKerrow P 2001. *Recognising plants with ultrasonic sensing for mobile robot navigation*. Robotics and Autonomous System, 34, 71-82
- Hayashi S, Shigematsu K, Yamamoto S 2009. *Evaluation of a strawberry-harvesting robot in a field test*. Biosystems Engineering, 105 (2), 160-171
- Hayashi S, Takahashi K, Yamamoto S, Saito S, Komeda T 2011. *Gentle handling of strawberries using a suction device*. Biosystems Engineering, 109 (4), 348-356
- Jeon H J, Tian L F 2009. *Direct application end effector for a precise weed control robot*. Biosystems Engineering, 104(4), 458-464
- Kassler M 2001. *Agricultural automation in the new millennium*. Computers and Electronics in Agriculture, 30, 237-240
- Kondo N, Monta M, Fujiura T (1996). *Fruit harvesting robots in Japan*. Adv. Space. Res., 18 (1/2), 181-184
- Kondo and Monta (1999). *Strawberry Harvesting Robots*. Proc. ASAE/CSAE-SCGR Annual International Meeting, Toronto, Ontario, Canada, July 18-21, Paper n. 993071
- Lamm R D, Slaughter D C, Giles D K 2002. *Precision weed control system for cotton*. Transactions of ASAE, 45, 231-238
- Lee W S, Slaughter D C, Giles D K 1999. *Robotic weed control system for tomatoes*. Precision Agriculture, 1, 95-113
- Leemans V, Destain M 2007. *A computer-vision based precision seed drill guidance assistance*. Computers and electronics in agriculture, 59 (1), 1-12.
- Mandow A, Gómez de Gabriel J M, Martínez Rodríguez J L, Muñoz V F, Ollero A, García-Cerezo A 1996. *The Autonomous Mobile Robot*

*AURORA for Greenhouse Operation*. IEEE Robotics and Automation Magazine, December, 18-28

Muscato G., Prestifilippo M., Abbate N, Rizzuto I (2005). *A prototype of an orange picking robot: past history, the new robot and experimental results*. Industrial Robot: An International Journal, 32 (2), 128-138

Nagasaka Y, Umeda N, Kanetai Y, Taniwaki K, Sasaki Y 2004. *Autonomous guidance for rice transplanting using global positioning and gyroscopes*. Computers and electronics in agriculture, 43 (3), 223-234

Nørremark M, Griepentrog H, Nielsen J, Søgaard HT 2008. *The development and assessment of the accuracy of an autonomous GPS-based system for intra-row mechanical weed control in row crops*. Biosystems Engineering, 101 (4), 396-410

Pedersen S M, Fountas S, Have H., Blakmore B. S. (2006). *Agricultural robots – system analysis and economic feasibility*. Precision Agriculture, 7, 295-308.

Peruzzi A, Raffaelli M, Frasconi C, Martelloni L, Fontanelli M, Sarri D, Lisci R, Rimediotti M, Vieri M 2012. *An autonomous ground mobile unit for the precision physical weed control*, Int. Conf. of Agricultural Engineering CIGR-AgEng2012, Valencia (Spain), July 8-12

Peterson D L, Bennedsen B S, Anger W C, Wolford S D 1999. *A system approach to robotic bulk harvesting of apples*. Transactions of ASAE, 42, 871-876

Rath T, Kawollek M 2009. *Robotic harvesting of Gerbera Jamesonii based on detection and three-dimensional modelling of cut flower pedicels*. Computers and electronics in agriculture, 66 (1), 85-92

Reed J N, Miles S J, Butler J, Baldwin M, Nobel R 2001. *Automatic mushroom harvester development*. Journal of Agricultural Engineering Research, 78, 15-23



- Ryu K H, Kim G, Han J S 2001. *Development of a Robotic Transplanter for Bedding Plants*. Journal of Agricultural Engineering Research, 78 (2), 141-146
- Sandini G, Buemi F, Massa M, Zucchini M 1990. *Visually guided operations in greenhouse*. IEEE International Workshop on Intelligent Robots and Systems IROS '90
- Slaughter D, Giles D, Downey D (2008). *Autonomous robotic weed control systems: A review*. Computers and electronics in agriculture, 61 (1), 63-78
- Søgaard H, Lund I 2007. *Application accuracy of a machine vision-controlled robotic micro-dosing system*. Biosystems Engineering, 96 (3), 315-322
- Sørensen C G, Madsen N A, Jacobsen B H 2005. *Organic farming scenarios: operational analysis and costs of implementing innovative technologies*. Biosystems Engineering, 91 (2), 127-137
- Sørensen C, Nørremark M, Jørgensen R, Jensen K, Maagaard J, Jensen L A 2007. *Hortibot: Feasibility study of a plant nursing robot performing weeding operations - part IV*. ASABE Annual International Meeting, Minneapolis, Minnesota 17 - 20 June 2007.
- Sørensen C G, Jørgensen R N, Maagaard J, Bertelsen K K, Dalgaard L, Nørremark M 2010. *Conceptual and user-centric design guidelines for a plant nursing robot*. Biosystems Engineering, 105 (1), 119-129
- Tanigaki K, Fujiura T, Akase A, Imagawa J 2008. *Cherry-harvesting robot*. Computers and Electronics in Agriculture, 63 (1), 65-72
- Tillett N D, Hague T, Marchant J A 1998. *A Robotic System for Plant-Scale Husbandry*. Journal of Agricultural Engineering Research, 69, 169-178
- Tillet N D, Hague T 1999. *Computer-vision-based Hoe guidance for cereals an initial trial*. Journal of Agricultural Engineering Research, 25, 225

- Tillet N D, Hague T, Miles S J 2002. *Inter-row vision guidance for mechanical weed control in sugar beet*. Computers and Electronics in Agriculture, 33, 163-177
- Tillett N, Hague T, Grundy A, Dedousis A 2008. *Mechanical within-row weed control for transplanted crops using computer vision*. Biosystems Engineering, 99 (2), 171-178
- Urbinati. 2012, official web site. [www.urbinati.com](http://www.urbinati.com)
- Van Henten E J, Hemming J, Van Tuijl B A J, Kornet J G, Bontsema J, Van Os E A 2003. *Field test of an autonomous cucumber picking robot*. Biosystems Engineering, 86, 305-313
- Van Henten E J, Van Tuijl B A J, Hoogakker G J, Van Der Weerd M J, Hemming J, Kornet J G, Bontsema J 2007. *An autonomous robot for de-leafing cucumber plants grown in a high-wire cultivation system*. Biosystems Engineering, 94, 317-323



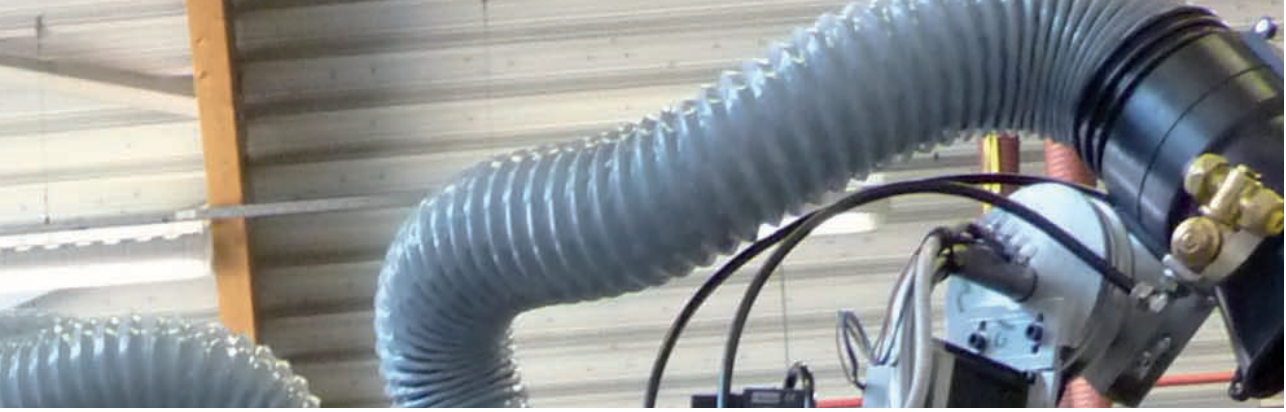

## Topic 2.1

# Design and control of automated agricultural vehicles and systems

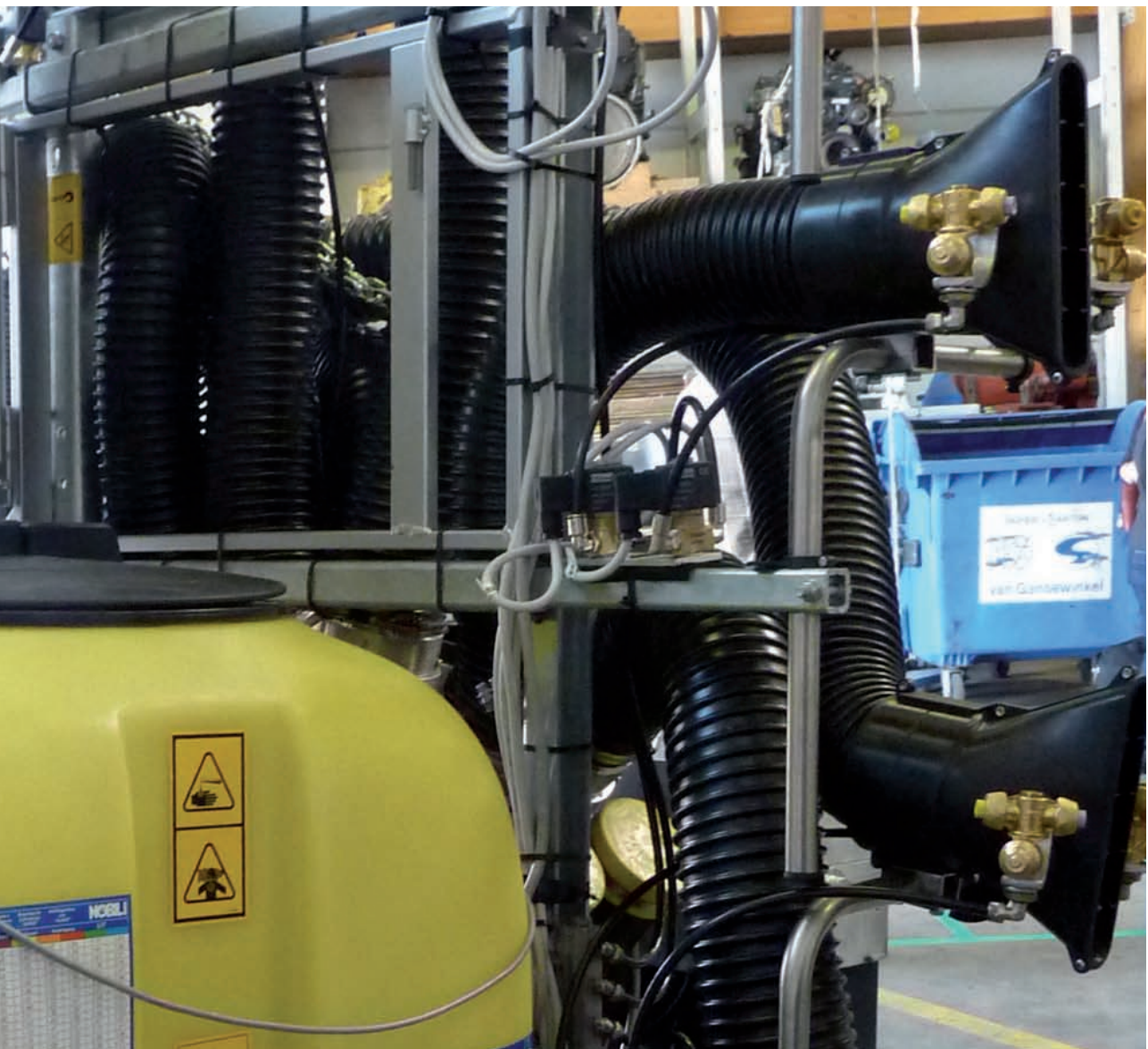

**Session 1:**  
Control algorithms  
for agricultural mobile robots





## TOPIC n°2.1

### Algorithms, for path following and planning, for agricultural robots.

Christian Correa<sup>1</sup>, Constantino Valero<sup>1</sup>, Pilar Barreiro<sup>1</sup>, Lorenzo Vasquez<sup>2</sup>

<sup>1</sup>Dept. of Agricultural Engineer, ETSIA, Technical University of Madrid, Av. Complutense s/n Ciudad Universitaria, Madrid, 28043, Spain, (ccorrea@udc.cl)

<sup>2</sup>School of Electrical-Electronics Engineering, University of Tarapaca, 18 de Septiembre, 2222, Arica, Chile, (lvasquez@uta.cl)

**Keywords:** Path Planning, tracking, mobile robot.

---

**Abstract:** The basis to perform any agricultural task by robots is to planning and following paths or trajectories inside the crops. This research aims to developed and implemented algorithms for following and planning (global and local) trajectories for agricultural robots. The global planning was performed using the A \* algorithm applied over crop maps and the local planning was performed using A\* applied over a 2D map obtained from 3D images of the obstacles present on the way. Trajectory following, was done by implementing a numerical approximation of the trajectory by Euler's method. The parameters for the dynamics of the robot trajectory's controller were obtained by genetic algorithms. The 3D map was generated from the Microsoft Kinect sensor, and its data processed by Matlab 2010b. Preliminary results show that these algorithms can be implemented in small robots designed to be used in crop rows. Thereby providing a robust methodology to following assigned paths with errors less than RMSE= 0.1 m in trajectories of 30 m.

---

## 1. Introduction

Mobile robots needs to have a complete understanding of the terrain and features around it if it is to be able to navigate complex environments safely (Softman et al., 2006). Reason



why, is essential to give it a safe path to follow, as well as sensors to detect and avoid unexpected obstacles.

In this research, we propose a set of algorithms aimed to solve the weeds control in row crops. In specific, we will address the path planning and following, soft curves generation to approximate these trajectories and finally, obstacles avoidance.

## **2. Materials and methods**

As described in Correa and Vasquez, (2012), we will divide the methodology in three sections: a) Path Planning with A\*. b) Trajectory smoothing. c) Trajectory Controller.

### ***2.1. Path Planning with A\****

In the proposed scenario, the robot must go from its current position to the nearest weeds point. As a result, a planning to connect these two points will be performed. This planning is called Global Planning and is performed by A\* algorithm.

Also, when the robot finds an obstacle a new planning will be performed. This planning is called Local Planning.

#### ***2.1.1 Global planning***

Assume that, the crop is divided into a grid and also that the robot is smaller than a square of this grid. We have three kind of cell in the grid: free, occupied by obstacles and occupied by weeds. A\* is responsible of finding the shortest route between the current position and the nearest weed point.

Once the robot removes the weeds on the site, performs again the planning operation to reach the nearest weeds point.

In Fig. 1a shows in red dots, the robot trajectory from its initial location to the closest weed's point. Then, takes this point as starting point and creates a new path, marked with black dots, to the next nearest weed's point. This is a cyclical process in which it moves from between weed's points.

#### ***2.1.2 Local planning***

When obstacles are detected by the Kinect sensor, a high-resolution 2d grid is generated as shows the Fig. 1b. Over this

grid, is performed a local planning by A\*, as shown in Fig. 1d and depicted in Correa and Vasquez, (2012).

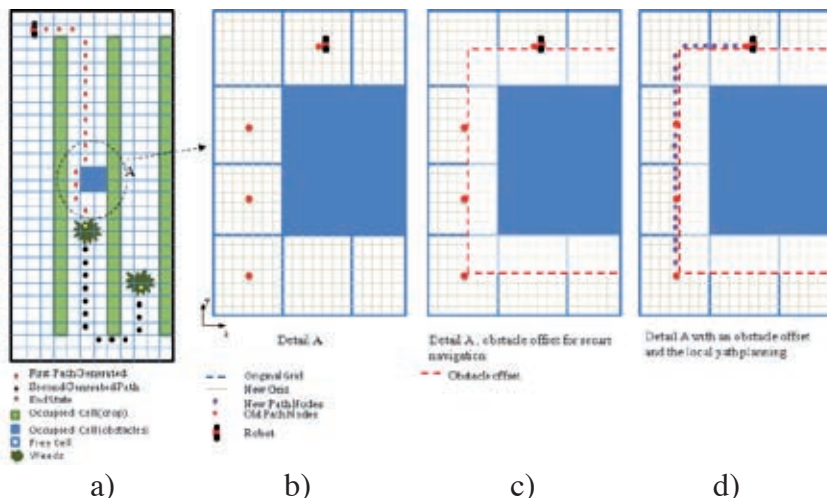

Fig.1. a) Paths generated by A\*. b) Details of the global path to avoid obstacles. c) Security offset. d) Local path planning.

## 2.2 Trajectory smoothing

Once the global trajectory points are generated by A\*, these points are connected by Bezier curves implemented by Casteljau algorithm as described in Choi et al. (2008).

## 2.3 Trajectory Controller

The trajectory controller proposed by Scaglia et al. (2006) was used and its parameters  $K_o$  y  $K_u$  optimized by genetic algorithm as in Correa and Vasquez, (2012).

## 3. Results and conclusions

Several simulations, in three different scenarios, were performed for different path with and without obstacles, and its error measured by RMSE.

**Scenario 1.** Shown in Fig. 2a, this scenario seeks to find the shortest path between the current robot position (coordinate [1.5, 18.5]) and the nearest weeds (coordinate [25.5, 13.5]) in a plot



of 16 rows, spaced 2 m. This path has 30 m and was performed in 162 ms by an Intel ® Core 2 Duo 1.6 GHz.

**Scenario2.** Depicted in Fig. 2b, a plot of 11 rows spaced 3 m has 14 obstacles (Blue). The robot starts from the point [2.5, 12.5] must reach the weeds on the coordinates [42.5, 4.5]. In this case, the trajectory (84.4 m) is successfully generated in 238 ms.

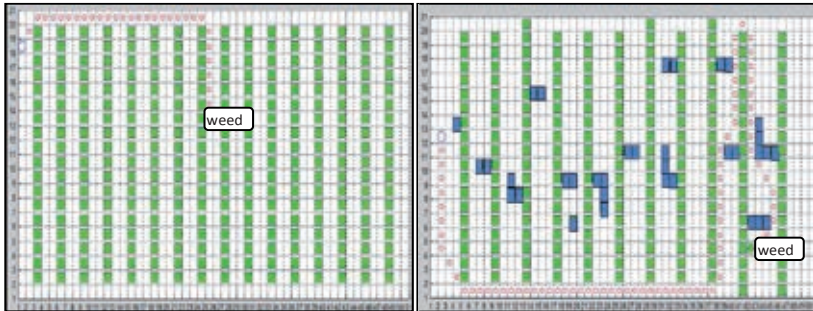

a) Path length: 30 m.                      b) Path length: 84.4 m.

Fig. 2. a) Scenario 1, path between simulated vines rows (50x20m). b) Scenario 2, path between simulated obstacles.

**Scenario3.** In the case of unexpected obstacles, a 3D images of in field obstacles (previously stored), were randomly added as shown in Fig. 2b.

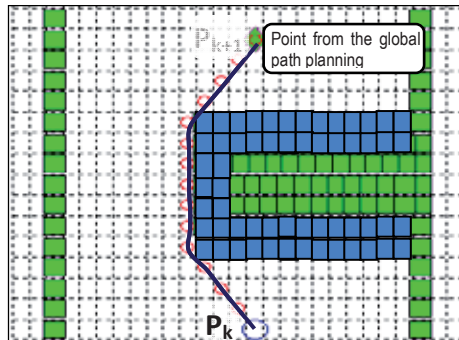

Fig. 3. Path for local obstacle avoidance and smoothing using cubic Bezier curves. ■ Offset of the obstacle.

**3.1 Smoothing paths with Bezier curves.** An example of the smoothing process is depicted on Fig. 4. This path is smooth and allows connecting points generated in the Scenario 1 in 340 ms.

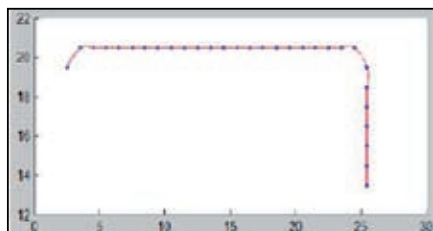

Fig.4. Smooth path using cubic Bezier curves, from Scenario 1.

### 3.2 Trajectory controller.

The Fig. 5a, shows the controller performance following the path (from the scenario 1) at desired speeds ( $0.2 \text{ m s}^{-1}$ ), using non-optimized controller parameters. The RMSE, is  $0.54 \text{ m}$  in this path of  $30 \text{ m}$ . However, the speed oscillated around  $0.4 \text{ m s}^{-1}$ , which is greater than  $0.2 \text{ m s}^{-1}$  of speed imposed as reference.

Note that the robot doesn't reach its goal, and has many oscillations around the path.

Furthermore, when using optimal parameters, founded by Genetic Algorithm, the robot reaches its destination with a  $\text{RMSE}=0.15 \text{ m}$ , and a maximum oscillations of  $0.16 \text{ m}$ , which guarantee a secure navigation.

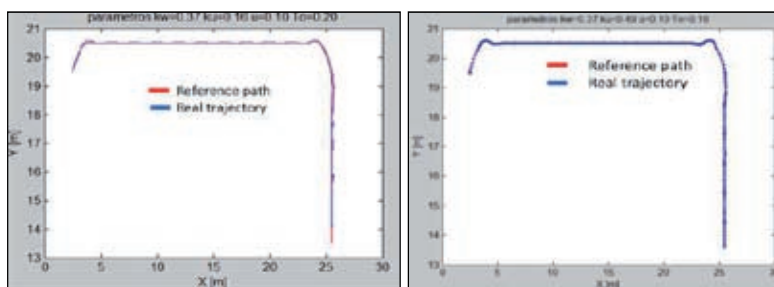

Fig. 5. Path following using controller parameters. a)  $K_{\omega}$  and  $K_u$  suboptimal. b)  $K_{\omega}$  and  $K_u$  optimal.

Additionally, the controller's performance is closely tied to the parameters  $K_{\omega}$  and  $K_u$ . For our analysis the values selected are those that minimize the RMSE.

The behavior of our frameworks on different scenarios, to finds paths and generate trajectories is robust enough. Because, if a



path to the goal exists, it guarantees to find an optimal path. But also, is efficient in terms of computation times.

The well proven A\* algorithm, has shows its effectiveness in generating both local and global trajectories and their efficiency in terms of run times (<300 ms, for the longest path). Making it suitable to be used on agricultural robots.

Local obstacles avoidance based on Kinect sensor, is suitable for objects detection, even if they are small size objects. Kinect detect objects larger than 3 cm).

In addition, local obstacle avoidance is a reliable alternative. Because, while the robot has room to pass through, the A\* algorithm, will find the lowest cost path. However, these paths tend to be closed curves, so it's necessary to reduce by half the robot's speed ( $0.1 \text{ m s}^{-1}$ ) in order to following closely the trajectories and prevent collisions in reduced spaces.

Finally, we think the greatest contribution of this work, lies in the integration of several techniques for: path planning and tracking, controller optimization and obstacle avoidance using 3D vision. Integration that, ensure an effective and safe navigation in agricultural environment. Combining classical techniques such as A\*, with new tools as the Kinect sensor.

## References

- CORREA, C. & VASQUEZ, L. Algoritmos para la planificación y seguimiento de trayectorias en robots agrícolas *X Congreso Latinoamericano y del Caribe de Ingeniería Agrícola e XLI Congreso Brasileiro de Engenharia Agrícola*, 2012.
- CHOI, J.-W.; CURRY, R. & ELKAIM, G. Path Planning Based on Bézier Curve for Autonomous Ground Vehicles. *Advances in Electrical and Electronics Engineering IAENG, IEEE*, 2008, 158-166
- SCAGLIA G., MUT V., QUINTERO O., DI SCIASCIO F., "Trajectory Control Of Mobile Robots Based On Numerical Methods", XII Congreso Latinoamericano de Control Automático - CLCA, Salvador, Brasil, (2006a).
- SOFMAN, B.; BAGNELL, J. A.; STENTZ, A. & VANDAPEL, N. Terrain classification from aerial data to support ground vehicle navigation Robotics, Citeseer, 2006



**TOPIC n° 2.1 Design and control of autonomous agricultural vehicles  
and systems**

**Integrating robot positioning controllers in the SEARFS  
simulation environment**

**Emmi, L.<sup>1</sup>, Pajares, G.<sup>2</sup> and Gonzalez-de-Santos, P.<sup>1</sup>**

<sup>1</sup> *Centre for Automation and Robotics (UPM-CSIC); 28500 Arganda del Rey; Madrid;  
Spain (e-mail: [luis.emmi@car.upm-csic.es](mailto:luis.emmi@car.upm-csic.es))*

<sup>2</sup> *Dpto. Ingeniería del Software e Inteligencia Artificial, Facultad Informática.  
Universidad Complutense, Madrid, Spain*

**Keywords:** Fuzzy logic controller, Autonomous robots,  
Agricultural vehicles.

---

**Abstract**

This article presents a control scheme for lateral error control on autonomous agricultural vehicles, based on Fuzzy Logic, and its implementation on the SEARFS simulation environment.

---

**1. Introduction**

A software architecture for an outdoor autonomous vehicle consists of four main elements (Li et al. 2009; Reid et al. 2000): Navigation sensors, Vehicle Motion Models, Navigation Planner and Steering Controller. In the last years, theoretical and practical important contributions have been made with respect to each of these four basic elements, oriented to mobile units for agricultural applications. The interest on incorporating advanced sensors and developing robust guidance systems to achieve reliable, robust, autonomous agricultural vehicles has increased (Belforte et al., 2006; Kassler, 2001; Slaughter et al., 2008; Zhang et al., 2002). Although, most of these researches have led to the development of different individual guidance technologies, another few have achieved full integration. Today, this integration is needed in order to offer a complete solution with a high benefit-cost ratio to the agricultural industry. Based on this need, a new control architecture for fleets of robots is





under development, which is intended for position control and precision guidance of an autonomous robot in crop management activities by merging information from different sources (machine vision, RTK-DGPS), laser-based sensors and inertial sensors, between others). This architecture will be first evaluated by using a robot fleet, open source simulation environment named SEARFS, that allows the user to evaluate different modules oriented to Precision Agriculture (vehicle models, control algorithms, terrain characteristics, crop and weed variabilities) (Emmi et al., 2012).

## **2. Simulation Environment for PA task using fleets of Robots (SEARFS)**

The SEARFS simulation environment was designed as an open-source computer application and is being developed with the purpose of providing a general programming system to:

- 1) Observe and evaluating different fleet of robots configurations while simulating the execution of various agricultural tasks
- 2) Implement different types of sensors and actuators in fleets of robots, and evaluating the robot cooperation behavior.
- 3) Generate missions for the fleet of robots for evaluation purposes
- 4) Represent the field characteristics in a 3D virtual universe, to improve understanding

SEARFS consist of two interfaces. The Graphical User Interface (GUI) is based on the Webots package (Cyberbotics, 2012), which allows the user to design complex robotic setups with different robots. The user can create 3D virtual worlds with physics properties such as mass, joints, and friction coefficients. A large number of sensors and actuators are already available in Webots.

The Configuration User Interface (CUI) allows the user to define the field characteristics and the parameters of the mission fleet that determine the specific task for each robot. For the

development of the CUI module, the Matlab computational tool has been selected

Another principal function of the CUI is to allow the user to specify the assignment that each robot should execute in the simulation.

### **3. Correcting the lateral positioning of agricultural vehicles**

In order to achieve a proper evaluation of the new software architecture, positioning control algorithms have to be implemented. This section focuses on how to implement those algorithms by using a fuzzy logic based method for vehicle path following as an integration example.

Several control algorithms for correcting lateral error for outdoors vehicles can be found such as: PID, feed-forward PID, fuzzy logic controllers, etc (Qiu et al. 1999; Wu et al. 2001; Xue et al. 2012; Zhang et al. 1999; Zhang et al. 2011). In this case, we propose an algorithm capable of following paths, both curves and straight, with the same rule base, and in both cases, obtain high accurate. Another feature which is sought on this controller is that the changes in the direction of the wheels must be soft, eliminating oscillations as much as possible.

The main task of the navigation controller is to determine the desired steering angle to correctly positioning the vehicle based on a predefined trajectory. For the controller presented in this work, a GPS signal and a predefined path are the inputs of the navigation. The controller segments the predefined path in waypoints, using a pre-set straight as the navigation path (See Fig. 1), where  $G(X_g, Y_g)$ ,  $C(X_c, Y_c)$ ,  $W(X_w, Y_w)$  are the vehicle current position (GPS position in the rear axle), the control point and the actual waypoint. The calculations of the lateral deviation,  $D$ , between the path and the vehicle are made with respect to the control point. As the control point is calculated based on the current velocity of the vehicle, is intended that the vehicle prior respond to changes in the lateral deviations, having a good stability and accuracy in the path following.

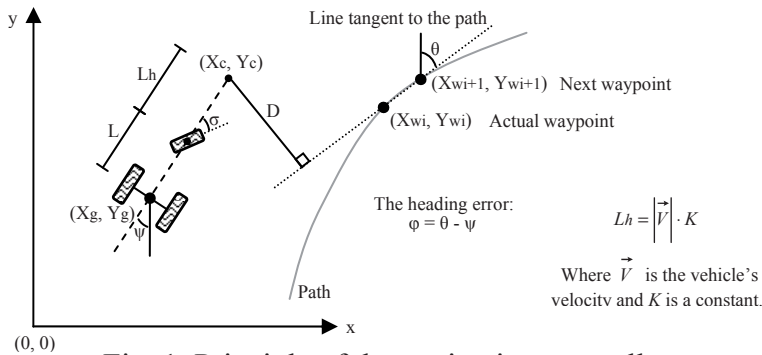

Fig. 1. Principle of the navigation controller.

The lateral deviation  $D$  and the heading error  $\varphi$  (See Fig. 1) are the inputs for the fuzzy logic controller. The steering angle of the front wheels is the output of the controller. Figure 2 illustrates the linguistic variables, the membership functions and the base rules.

The control algorithm has been evaluated in the SEARFS simulation environment for mobile robots fleets over a Boomer T3050 model (Cyberbotics, 2012), an agricultural, commercial vehicle, equipped with a set of sensor systems that are usually used in PA applications. The control algorithm uses the information of a GPS and an inertial measurement unit (IMU) in order to correct the lateral error of the vehicle and their attitude while follows a predefined path that consist of three different

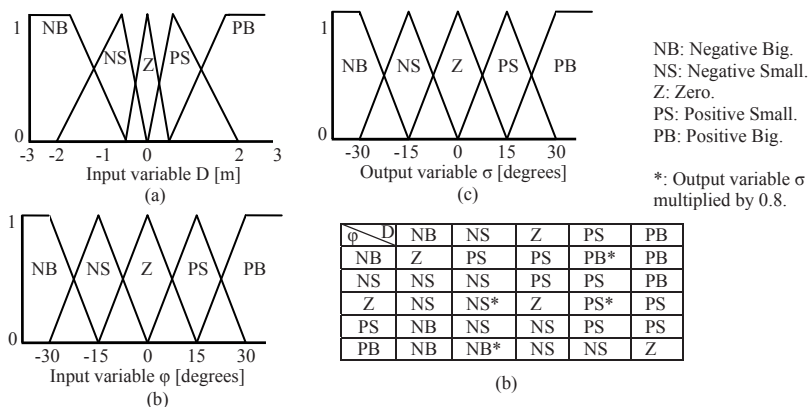

Fig. 2. Membership functions for: (a) lateral deviation; (b) heading error; (c) steering angle. (d) Base rule.



Fig. 3. Structure of the mobile units' controller for SEARFS.

segments: soft right turn (sinusoidal waveform), hard right turn (circular waveform) and a straight line. The kinematic model used in the simulation was the Ackermann steering geometry.

#### **4. Implementing the controller in SEARFS**

Basically, a controller in SEARFS consist of a certain number of inputs (information that can be obtained both in “real-time” or prior to the start of the task execution) and outputs (control of the various actuators that compose the robot) (See Fig. 3). One of the key elements of this controller is the “Trajectory tracking” module. This module is defined by a function that should give, in each iteration time, the desired angle of the front wheels. Given the inputs and the fuzzy logic elements presented in the previous section, and aided by the programming tools given by MATLAB, the algorithm for controlling the lateral error presented in this work have been successfully implemented in SEARFS.

#### **5. Results and conclusions**

This article presents how to integrate simple positioning controllers in SEARFS in order to simulate the motion of fleets of robots. The control algorithm selected is a simple, efficient and reliable way to control small/medium sized robot, at crop management working speed, and resulted to be promising in the real control of agricultural vehicle.

#### **Acknowledgements**

*The research leading to these results has received funding from the European Union's Seventh Framework Programme [FP7/2007-2013] under Grant Agreement n° 245986.*

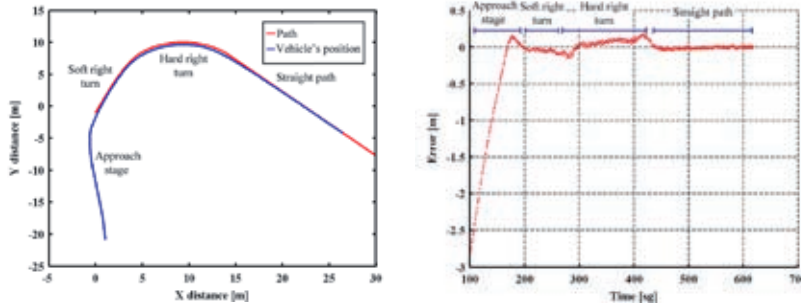

Fig. 4. Evaluation of the fuzzy logic positioning controller for lateral error correction. (Left) Position of the vehicle (blue) while following the user-defined path (red). (Right) Lateral error in the different stages of the path.

## References

- Belforte, G., Deboli, R., Gay, P., Piccarolo, P., Ricauda Aimonino, D., 2006. *Robot Design and Testing for Greenhouse Applications*. Biosystems Engineering, 95, pp. 309–321.
- Cyberbotics. 2012. “Webots: robot simulator”. <http://www.cyberbotics.com/>.
- Emmi, L., Paredes-Madrid, L., Ribeiro, A., Pajares, G. and González-de-Santos, P. 2012. *Robot fleet for precision agriculture: A simulation environment*. Computers and Electronics in Agriculture (Submitted).
- Kassler, M., 2001. *Agricultural Automation in the new Millennium*. Computers and Electronics in Agriculture, 30(1-3), pp. 237–240.
- Li, M., Imou, K., Wakabayashi, K., Yokoyama, S., 2009. *Review of research on agricultural vehicle autonomous guidance*. International Journal of Agricultural and Biological Engineering, 2, pp. 1–16.
- Qiu, H., Zhang, Q., Reid, J.F., Wu, D., 1999. *Nonlinear feedforward-plus-PID control for electrohydraulic steering systems*. Fluid Power Systems and Technology, 6, pp. 89–94.
- Reid, J.F., Zhang, Q., Noguchi, N., Dickson, M., 2000. *Agricultural automatic guidance research in North America*. Computers and Electronics in Agriculture, 25, pp. 155–167.
- Slaughter, D.C., Giles, D.K. & Downey, D., 2008. *Autonomous robotic weed control systems: A review*. Computers and Electronics in Agriculture, 61(1), pp. 63–78.
- Wu, D., Zhang, Q., Reid, J.F., 2001. *Adaptive steering controller using a Kalman estimator for wheel-type agricultural tractors*. Robotica, 19, pp. 527–533.
- Xue, J., Zhang, L., Grift, T.E., 2012. *Variable field-of-view machine vision based row guidance of an agricultural robot*. Computers and Electronics in Agriculture, 84, pp. 85–91.
- Zhang, M., Ma, W., Liu, Z., Liu, G., 2011. *Fuzzy-adaptive control method for off-road vehicle guidance system*. Mathematical and Computer Modelling. In Press.
- Zhang, N., Wang, M., Wang, N., 2002. *Precision agriculture—a worldwide overview*. Computers and Electronics in Agriculture, 36(2-3), pp. 113–132.
- Zhang, Q., Reid, J.F., Noguchi, N., 1999. *Agricultural vehicle navigation using multiple guidance sensors*. In: Proceedings of the International Conference on Field and Service Robotics.



TOPIC n° 2.1

## Model Predictive Control of the Yaw Dynamics of an Autonomous Tractor

Erkan Kayacan, Erdal Kayacan, Herman Ramon, Wouter  
Saeys

*The Division of Mechatronics, Biostatistics and Sensors, Department of Biosystems,  
KU Leuven, Kasteelpark Arenberg 30, B-3001 Leuven, Belgium (e-mail:  
{erkan.kayacan, erdal.kayacan, herman.ramon, wouter.saeys}@biw.kuleuven.be)*

**Keywords:** model predictive control, autonomous tractor

---

**Abstract:** This paper presents the yaw rate control of an autonomous tractor. Since the autonomous tractor is generally working on various types of fields and there are many time-varying parameters in the dynamics of the system, a control algorithm (an MPC in this case) which is able to optimize itself online is welcome. Another reason why an MPC controller is used in this study is its capability of operating without expert intervention for long periods. Since the MPC has prediction capability, it gives more satisfactory performance when compared to a conventional PID controller. The experimental results show the accuracy and efficiency of the proposed control scheme.

---

### 1. Introduction

Food consumption is increasing dramatically all over the world, unlike the arable area is limited and also decreasing due to the climate change. For this reason, the agricultural productivity becomes a very popular issue in engineering field. Even the productivity per hectare has increased due the fact that the capacity of the machinery has expanded, the cost of the manpower became an economic pressure. One possible solution is automation of agricultural machineries to improve the efficiency and productivity of various field operations and reduce the cost.



Model predictive control (MPC) approach, which is used in industry since the 1980s, is a common predictive control method. The aim of MPC approach is to minimize a performance criterion with respect to constraints of a system's inputs and outputs. There are many implementations of MPC in literature. For example, a non-linear model predictive control (NMPC) is proposed to get more accurate lateral position of a trailer system in (Backman et al., 2012). The lateral position error of the trailer is obtained less than 10 cm in straight paths in real-time. Another NMPC algorithm with non-linear set membership identification methodology is proposed for vehicle yaw control in (Canale et al., 2011). It is observed that the control structure has better closed-loop robustness than classic approaches. A disturbance compensating MPC algorithm has been applied to ship heading control (Li and Sun 2012). The result of this study has showed that the proposed algorithm has the ability of eliminating the steady-state error.

In this paper, the yaw dynamics is given considering various types of soil conditions. Linear model is used to calculate the lateral forces on the tires. The relaxation length is defined to obtain more precise side-slip angles. After giving the dynamic model, an MPC with integral action approach is used to control the system in real-time experiments in order to handle steady-state error due to mismatch model problem and uncertainties.

## 2. Materials and methods

### 2.1 Vehicle yaw dynamics

The tractor is driven on the field with a constant longitudinal velocity as required in automatic guidance of agricultural vehicles. Therefore, longitudinal slips happen only while the system is arriving the desired constant velocity and stopping. Consequently, the traction forces can be neglected and  $\dot{u}$  will be equal to zero. As a result, equations of motion are written as follows:

$$m\dot{v} = -muy - C_{\alpha,f}\alpha_f - C_{\alpha,r}\alpha_r$$

$$I\dot{\gamma} = -l_f C_{\alpha,f}\alpha_f + l_r C_{\alpha,r}\alpha_r$$



$$\begin{aligned}\dot{\alpha}_f &= \frac{v + l_f \gamma - u(\delta + \alpha_f)}{\sigma_f} \\ \dot{\alpha}_r &= \frac{v - l_r \gamma - u\alpha_r}{\sigma_r}\end{aligned}\quad (1)$$

where  $m$ ,  $I$ ,  $u$ ,  $v$ ,  $\gamma$ ,  $l_f$ ,  $l_r$ ,  $F_{t,f}$ ,  $F_{t,r}$ ,  $F_{l,f}$ ,  $F_{l,r}$ ,  $C_{\alpha,f}$ ,  $C_{\alpha,r}$ ,  $\alpha_f$  and  $\alpha_r$  are the mass of the tractor, the moment of inertia of the tractor around the vertical axis, the longitudinal and lateral velocities of the center of the gravity of the tractor, the yaw rate of the center of the gravity of the tractor, the distance between the front axle and the center of the gravity of the tractor, the distance between the rear axle and the center of the gravity of the tractor, the traction forces on the front and the rear wheels of the tractor, the lateral forces on the front and the rear wheels of the tractor, the cornering stiffness of the front and rear wheels of the tractor, the side slip angles of the front and rear wheels of the tractor, respectively. The velocities, sideslip angles and forces at different locations of an autonomous tractor are also presented in Fig. 1.

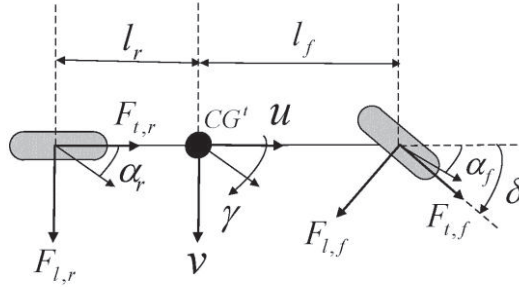

Fig. 1. Dynamics bicycle model for a tractor-implement system: velocities, side slip angles and forces at different locations of the system.

## 2.2 MPC with integral action

MPC formulation is extended to include integral action. This is important to eliminate the steady state offset in the process outputs resulting from step disturbances and to compensate for the model mismatch between the MPC controller model and the



plant model. To formulate MPC with integral action (MPC-I), the integrator state is written as follows:

$$v(k+1) = y(k) + v(k) \quad (2)$$

where  $v$  is the integrator state. The augmented system model can be written after combination of system model and integrator as follows:

$$\begin{aligned} \xi(k+i+1|k) &= \begin{bmatrix} A & 0 \\ C & I \end{bmatrix} \xi(k+i|k) + \begin{bmatrix} B \\ 0 \end{bmatrix} u(k+i|k) \\ y(k+i|k) &= [C \quad 0] \xi(k+i|k) \end{aligned} \quad (3)$$

$$\text{where } \xi(k+i|k) = \begin{bmatrix} x(k) \\ v(k) \end{bmatrix}.$$

The control law  $u_{MPC-I}$  can be written by using above state-space representation as follows:

$$u(k) = u^*(k|k) + K_I v(k) \quad (5)$$

where  $K_I$  is an integral gain.

The cost function to include a penalty on the integrator state in its general form is written to ensure stability and performance as follows:

$$J = \sum_{i=0}^{N_p} \xi_{k+i|k}^T Q_\xi \xi_{k+i|k} + \sum_{i=0}^{N_u-1} u_{k+i|k}^T R u_{k+i|k} \quad (6)$$

where  $\xi$  is the state of an augmented system that consists of the system state and integrator state and  $Q_\xi$  is positive-definite weighting matrix as following:

$$Q_\xi = \begin{bmatrix} Q & 0 \\ 0 & Q_I \end{bmatrix} \quad (7)$$

### 3. Experimental results

For the steering control the existing power steering unit has been replaced by a electro-hydraulic valve. The voltage and the rate of the steering angle became the input and the output for the steering system, respectively. An EH-valve from Sauer Danfoss with a flow of 12 liter/min has been installed. The valve characteristics are highly nonlinear and include a saturation and a dead-band region. For this reason, data were taken to identify

the steady state characteristics of the steering valve. Identification of the steady state slew rate versus input voltage has been used to invert the nonlinear characteristics of the steering valve. Once the steady state characteristic of the steering actuator are known, it is assumed that the valve nonlinearity is perfectly inverted. Consequently, the rate of the steering angle became the input of the steering mechanism. The autonomous tractor is shown in Fig. 2. The sampling period of the experiment is set to 0.05 s.



Fig. 2. The autonomous tractor

Figure 3a shows the yaw rate response of the autonomous tractor with MPC-I controller. As can be seen, the MPC-I controller controls the yaw dynamics satisfactorily without any steady state error and overshoot. The system error is shown in Fig 3b.

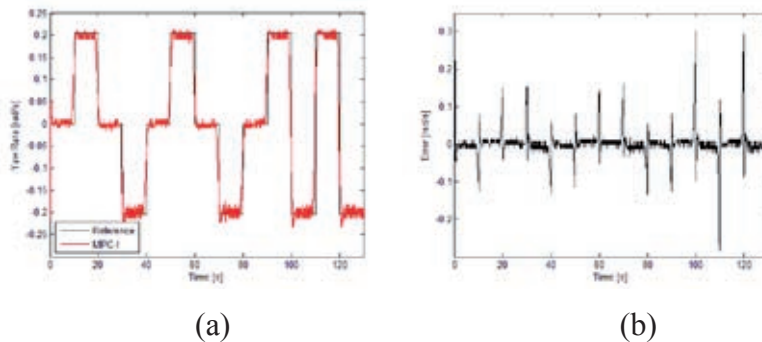



Fig. 3. The yaw rate response (a) and the error (b) of the autonomous tractor for MPC-I controller

When the results in this paper are compared, it can be concluded that MPC-I has better control capability of the yaw dynamics of the autonomous tractor.

#### 4. Conclusion

In this study, control aspects of an autonomous tractor are investigated. The equations of motion are given and the state-space formulation for the equation of dynamic model has been modified with respect to system's input and output. An MPC-I controller is designed for closed-loop control of the yaw rate of the autonomous tractor. The performance of the proposed mathematical model and control algorithm have been validated in real-time experiments. It is observed that the proposed MPC-I controller resulted in a better closed-loop behaviour when compared to conventional controllers.

#### Acknowledgment

*This work has been carried out within the framework of the LeCoPro project (grant nr. 80032) of the Institute for the Promotion of Innovation through Science and Technology in Flanders (IWT-Vlaanderen). We would like to thank Mr. Soner Akpinar for his technical support for the preparation of the experimental set up.*

#### References

- Backman, J., T. Oksanen, and A. Visala (2012). Navigation system for agricultural machines: Nonlinear model predictive path tracking. *Computers and Electronics in Agriculture*, 82, 32–43.
- Canale, M., L. Fagiano, and M. C. Signorile (2011). A model predictive control approach to vehicle yaw control using identified models. *Proceedings of the Institution of Mechanical Engineers, Part D: Journal of Automobile Engineering*.
- Li, Z., and J. Sun (2012). Disturbance compensating model predictive control with application to ship heading control. *IEEE Transactions on Control Systems Technology*, 20, 1, 257–265.



**First RHEA International Conference on  
Robotics and associated High-technologies  
and Equipment for Agriculture**  
Hosted by the University of Pisa  
Pisa, Italy, September 19-20-21, 2012



**TOPIC n° 2.1: Design and control of automated agricultural vehicles  
and systems**

**Search strategies and the automated control of plant  
diseases**

**Juan Duque Rodríguez<sup>1,2</sup>, Javier Gutiérrez López<sup>1</sup>,  
Valeriano Méndez Fuentes<sup>4</sup>, Pilar Barreiro Elorza<sup>1</sup>, David  
Gómez-Ullate<sup>2,3</sup>, Carlos Mejía-Monasterio<sup>1,2</sup>**

<sup>1</sup>*LPF-TAGRALIA, Department of Rural Engineering, Technical University of Madrid,  
Av. Complutense s/n, Madrid, 28040 Spain*

<sup>2</sup>*CEI Campus Moncloa, UCM-UPM, Madrid, Spain*

<sup>3</sup>*Department of Theoretical Physics II, Complutense University of Madrid, Av.  
Complutense s/n, Madrid, 28040 Spain*

<sup>4</sup>*Department of Applied Mathematics, Technical University of Madrid, Av.  
Complutense s/n, Madrid, 28040 Spain*

**Keywords:** disease-control, odour sensing, search algorithms,  
robotics, crop production

**Abstract:** We propose the use of the “infotaxis” search strategy as the navigation system of a robotic platform, able to search and localize infectious foci by detecting the changes in the profile of volatile organic compounds emitted by an infected plant. We build a simple and cost effective robot platform that substitutes odour sensors in favour of light sensors and study their robustness and performance under non ideal conditions such as the existence of obstacles due to land topology or weeds.

## **1. Introduction**

Plant diseases represent a major economic and environmental problem in agriculture and forestry. Upon infection, a plant develops symptoms that affect different parts of the plant causing a significant agronomic impact. As many such diseases spread in time over the whole crop, a system for early disease detection can aid to mitigate the losses produced by the plant



diseases and can further prevent their spread (Sankaran et al., 2010). Moreover, plant diseases are commonly mitigated by the generalized use of chemical pesticides applied over the whole crop, leading to ground and water pollution. Successful techniques for the detection of plant diseases must be fast, reliable, preferentially specific to a particular disease, cost-effective, and sensitive enough for their application at the early onset of the disease symptoms (Lopez et al., 2003).

Current approaches for the detection of plant diseases are divided in two groups, one involving the spectroscopic and imaging techniques and another based on the application of Volatile Organic Compounds (VOC) as possible biomarkers of the presence of disease (Zhan et al., 2010). Here we propose an automated non-destructive methodology based on chemosensing microtechnology and mathematical search algorithms to localize the position of infectious *foci* by detecting the changes in the profile of VOC characteristic of an infected plant.

Odour localization is a major challenge in robotics, mainly because odour plumes consist of turbulent non-uniform patches dispersed by the wind, and several synthetic mathematical algorithms of odour localization have been proposed (Kowadlo & Russell, 2008). We propose the infotaxis search algorithm as the navigation system of a robotic platform. Infotaxis (Vergassola et al., 2007). The use of infotaxis has been recently studied as a navigation system for robots in (Moraud et al., 2010) using temperature sensors and in (Garcia Ramirez et al., 2011) using electronic noses in a controlled environment. Here instead, we propose to avoid the current technical limitations involved in chemical sensing by using optical sensors. We show that, with tools commonly available in any university, a robot platform can be constructed and used to evaluate the robustness of search algorithms under non-ideal (laboratory) conditions.

## **2. Materials and methods**

We have designed and built a minimal robot platform to study the performance and robustness of search algorithms under realistic environments.

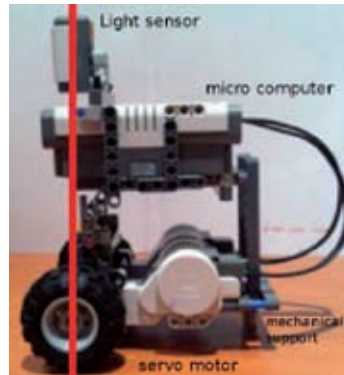

Fig. 1. Minimal design of the robot platform. The vertical line indicates the alignment of the light sensor with axis of rotation.

### **2.1 Minimal robotic design**

A mobile robot was designed using the hardware set of NXT LEGO (<http://mindstorms.lego.com/>). The robot design, consisted in two servo motors each controlling one wheel. Both wheels were axially aligned and a third fixed mechanical support was placed on the back of the platform. The robot was equipped with one single light sensor pointing upwards. The motors and data acquisition was controlled by one inline NXT micro-computer, programmed in java for LEGO Mindstorms (<http://lejos.sourceforge.net/>) using the Eclipse IDE.

### **2.2 Infotaxis algorithm**

The infotaxis strategy (Vergassola et al., 2007) assumes that the information comprises molecules that are emitted by the source at a rate  $\gamma$ , and are transported by turbulent air flow, characterized by a mean wind velocity  $V$  and diffusion coefficient  $D$ . The searcher is assumed to know at any instant of time  $t$  and position  $\mathbf{r}$  the expected probability to make a detection  $R(\mathbf{r}|\mathbf{r}_o)$ , given that the source is in the position  $\mathbf{r}_o$ . The infotactic searcher starts exploring the space and collects information in terms of the detections or no detections of molecules. Using this information and Bayesian inference, it reconstructs the posterior probability, called belief function,  $P_t(\mathbf{r}_o)$  of the unknown position of the source. Finally, the





searcher chooses its next position as that at which the decrease of Von Neumann entropy  $S$  is highest, thus maximizing the gain of information at every move.

### 2.3 Infotaxis as navigation system

To implement the infotaxis algorithm as the robot navigation system we assume that the robot sensors are capable of measuring a finite number  $k$  of detections. For simplicity, we assume as well that the robot can only move in four different directions (forward, backward, right or left) with a fixed step length  $\sigma$ , or stands still. This is schematically exemplified in Fig. 2. When the robot is at position  $r$  at time  $t$ , infotaxis reconstructs the belief function (shown as contour curves in Fig. 2), with associated entropy  $S$ . The algorithm then determines the next movement of the robot as that for which the decrease in entropy  $\Delta S$  is maximal. The robustness of the search is ensured by the exponential decay observed in the distribution of search times. For a discussion of robustness in search strategies we refer the reader (Mejia-Monasterio et al., 2011).

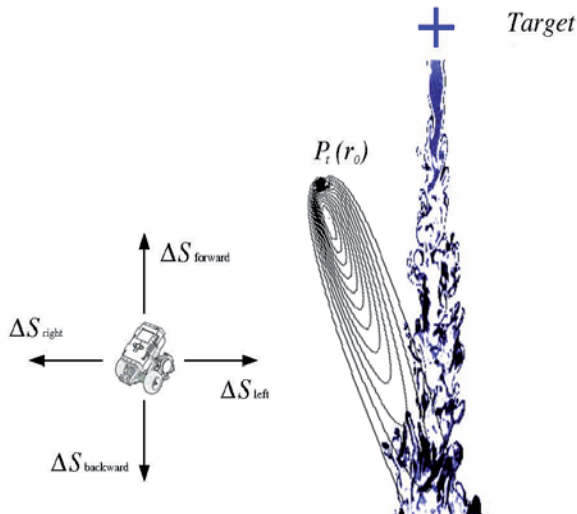

Fig. 2. Schematic representation of the steps involved in the infotaxis algorithm.

### 3. Results and conclusions

We simulate odour molecules as circular white light spots of radius  $\rho$  at a position that is chosen randomly according to the probability  $R(\mathbf{r}|\mathbf{r}_o)$ . The light spots are vertically projected with a commercial beamer on the ground, covering an area of 1.8 by 2.2 meters in which the robot moves with its light sensor pointed upwards, and last for a time  $T$ . Several tests were performed to find optimal values for  $\rho$ ,  $T$ , and the speed  $v$  of the robot. The light sensor was then set to record data every 3 ms, with a detection threshold of 450 in absolute units. The number of detections  $\eta$  was obtained as the sensor response integrated during the motion of the robot. The infotaxis algorithm was programmed in Fortran 90 language and compiled using the Intel Fortran compiler (<http://software.intel.com/>). The communication between the NXT processor and the infotaxis algorithm (running on a separate computer) was achieved via the exchange of text files. The NXT sends the number of detections  $\eta$  during its last movement and its direction. Infotaxis use  $\eta$  and the current position of the robot to compute the next movement and sends back two integers  $\theta=\{-90,0,90,180\}$  and  $d=\{0, \sigma\}$ , to the NXT. The robot rotates  $\theta$  degrees and move for a distance  $d$ .

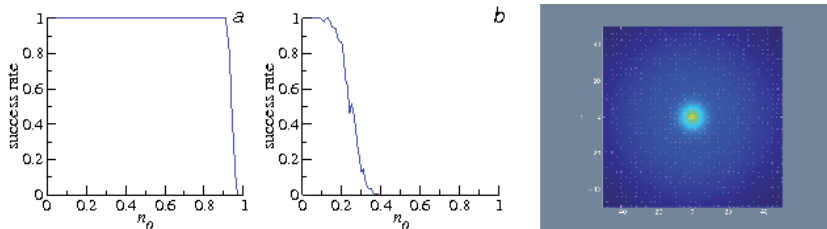

Fig. 3. Panels *a* and *b* show the success rate of the robot trials locating the target as a function of the density of obstacles  $n_o$ , when it moves in a triangular and square lattice respectively. The right panel shows the density of lattice sites visited by the robot for a square lattice with obstacles.

We have tested the robot trajectories through numerical simulations and studied the performance of infotaxis in the presence of obstacles placed randomly on square and triangular

lattices with density  $n_0$ . The results in Fig. 3, show that the search on a triangular geometry is more robust. This is of special relevance since crops under triangular geometries has shown to be more effective in the production of biomass compared to the traditional furrow geometry (Morente et al. 2011). Our results show that infotaxis is a promising strategy for the location of infectious foci in crops. While the technology required to achieve this goal does not exist yet, this study paves the road for future developments and for the optimization of search strategies as a method for early stage control of plant diseases.

### Acknowledgements

*Support from EU-project “Robot Fleets for Highly Effective Agriculture and Forestry Management” project (RHEA) no. 245986 is acknowledged. J. D. R. was partially supported by a PICATA predoctoral fellowship of the Moncloa Campus of International Excellence (UCM-UPM).*

### References

- Sankaran,S., Mishra,A., Ehsani,R. and Davis,C. (2010) *A review of advanced techniques for detecting plant diseases*. Computers and Electronics in Agriculture, 72, 1-13.
- López,M.M., Bertolini,E., Olmos,A., Caruso,P., Gorris,M.T., Llop,P., Penyalver,R. and Cambra,M. (2003) *Innovative tools for the detection of plant pathogenic viruses and bacteria*. International Microbiology, 6, 233-243.
- Zhang,Z. and Li,G. (2010) *A review of advances and new developments in the analysis of biological volatile organic compounds*. Microchemical Journal, 95, 127-139.
- Kowadlo,G and Russell,R.A. (2008) *Robot Odor Localization: A Taxonomy and Survey* International Journal of Robotics Research, 27, 869-894 .
- Vergassola,M., Villermaux,E. and Shraiman,B.I. (2007) *“Infotaxis” as a strategy for searching without gradients*. Nature, 445, 406-409.
- Moraud, E. and Martínez, D. (2010) *Effectiveness and robustness of robot infotaxis for searching in dilute conditions* Frontiers in Neurorobotics, 4, 1-8.
- García Ramírez,A.R., Blanco Rodríguez,A. and De Pieri,E.R. *An infotaxis based odor navigation approach* In Proceedings of 2011 IEEE International Conference on Biosignals and Biorobotics, (pp. 1-6).
- Mejía-Monasterio,C., Oshanin,G. and Scherer G. (2011) *First passages for a search by a swarm of independent random searchers* J. Stat. Mech.: Theor. and Exp., P06022.
- Morente,F., Barreiro Elórza,P., Dias da Costa,G.S., Griepentrog,H. and Hernández Díaz-Ambrona,C.G. (2011) *Rediseño del marco de siembra en maíz forrajero* In López Carrasco,C. et al, (Eds.) Pastos: Paisajes culturales entre la tradición y los nuevos paradigmas del siglo XXI. (pp. 237-242).

**Session 2:**  
Manipulation in agricultural tasks





**First RHEA International Conference on  
Robotics and associated High-technologies  
and Equipment for Agriculture**  
Hosted by the University of Pisa  
Pisa, Italy, September 19-20-21, 2012



## **A software framework for agricultural and forestry robotics**

**Thomas Hellström, Ola Ringdahl**

*Department of Computing Science, Umeå University, SE-901 87 Umeå, Sweden*

*e-mail: [thomash@cs.umu.se](mailto:thomash@cs.umu.se) [ringdahl@cs.umu.se](mailto:ringdahl@cs.umu.se)*

**Keywords** robot architecture, architecture view, middleware, ROS

---

### **Abstract:**

In this paper we describe on-going development of a generic software framework for development of agricultural and forestry robots. The goal is to provide generic high-level functionality and to encourage distributed and structured programming, thus leading to faster and simplified development of robots. Different aspects of the framework are described using different architecture views. We show how these views complement each other in a way that supports development and description of robot software.

---

### **1. Introduction**

Construction of software has become an increasingly complex and time-consuming part of robot development. In this paper, we present on-going development of a software framework for development of agricultural and forestry robots within the CROPS project (<http://www.crops-robots.eu/>). The goal is to provide generic high-level functionality and to encourage distributed and structured programming, thus leading to faster and simplified development. The framework will be used for the development of several robots with slightly different tasks, which means that it has to be general and possible to configure in several respects. The main contribution in the paper is the hybrid architecture of this framework. Different aspects of the framework are described using different architecture views. We



show how these views complement each other in a way that supports development and description of the system.

## 1.1 Background

In the field of mobile robotics, several *robot architectures* have been proposed over the years. They all describe different approaches how to organize sensing, planning, motion, cognition, and control. Most architectures follow one of the classical paradigms Deliberative, Reactive, or Hybrid (Mataric 2002). In software engineering, the concept of architecture has been thoroughly investigated and developed. According to the definition in ISO/IEC/IEEE 42010 (International Organization for Standardization 2007), an architecture is the “fundamental concepts or properties of a system in its environment embodied in its elements, relationships, and in the principles of its design and evolution”. Depending on which elements and relationships we consider, different types of *architecture views* are described. The following architecture views are often used to describe software-intensive systems (Kruchten, 1995): Logical view, Development view, Process view and Physical view. Each one of these architecture views describes important and complementary aspects of a system.

## 2. Materials and methods

In this section, the architecture of the framework developed for robots within the CROPS project will be described with reference to the different views described in the previous section.

### 2.1 Logical view

Defines top-level functionality, general modules and their relationship. In our case, this is mostly described in the specification documents for the CROPS robots. According to these, the robots should be able to determine locations of ripe and healthy fruit in the vicinity of the robot, determine appropriate picking order, plan a route to individual fruits, move to a fruit, determine how to grip a fruit, grip a fruit, determine how to cut a fruit, cut a fruit, and finally bring a fruit to a basket. All this should be done in a safe manner both for humans



working close to the robot, and for fruits and plants. The same software framework should work for development of different robots for harvesting of apples, sweet pepper, and grapes. Based on this specification, the following generic functional modules are identified: *Main control program*: runs the main loop that detects fruits, plans and executes motion, gripping, and harvesting. *Virtual sensors*: abstractions of sensors that do not only measure the physical world, but also process results from one or several physical, or virtual, sensors. *Planner*: generates plans for picking order, grasp patterns, and possibly also motion planning. *Arm and gripper control*: provides an interface to the robot arm (Baur et al. 2012), gripper, and cutter. *Error manager*: detects and handles situations when things go wrong. *Resource manager*: lets the user tune and configure the system for a task (choice of sensors, algorithms, parameters etc.). *Graphical user interface*: allows a user to start, pause, stop, and inspect the robot. *Fusion/Learning*: creates and adapts virtual sensors. *Performance monitor*: checks the health of all modules and communication channels (for instance physical connections and data flows).

## **2.2 Development and process view**

The development view describes the organization of software modules and how they communicate to fulfil non-functional requirements such as performance and availability. This description specifies programming and software development paradigms such as object orientation, component based approaches, and model driven design. The process view describes issues related to concurrency, distribution versus centralization, and communication modes (such as point-to-point or publish-subscribe). In the CROPS project, most development is done using the ROS (Robot Operating System) environment (Quigley et al. 2009), with programming done in C++, which encourages object-oriented systems. ROS manages parallel execution of software modules (denoted nodes) and administrates Ethernet based communication between nodes. ROS also supports transparent physical relocation of nodes and contains other useful functionality. In our case, most aspects of



the development and process views are jointly described by a directed graph, with vertices representing ROS nodes, and links representing information flow (ROS message passing).

### ***2.3 Physical view***

This view describes placement of physical components and physical connections, and takes into account non-functional system requirements such as availability, reliability, performance, and scalability (Kruchten, 1995). In our case, this view is illustrated as a block diagram showing how laptops, sensors and actuators communicate through a standard Ethernet bus with possibility to connect also CAN based equipment. The hardware is used to implement the functionality described by the Logical view, and also the application specific functionality according to the specification documents. Thanks to the ROS environment, the physical location of software modules within the ROS domain is very flexible. This means that processor-intensive computations, if necessary, can be moved to separate laptops without any changes in the programs.

### ***2.4 Robot architecture***

We further develop the architecture by specifying and designing how the different modules function and interact. This specification is affected by the design choices described in the Logical, Development, Process and Physical views. The result is a robot architecture that follows the hybrid paradigm.

The planner component commonly found in hybrid architectures is replaced by a static state machine. This is viewed as a good solution for the CROPS robots, and for other robots when there is no need for planning in the sense of problem solving or finding novel solutions to new tasks. This is the case if the given task for the robot is well defined, and the behaviour of the robot can be described in, for instance, a flowchart.

The proposed architecture also differs from the standard hybrid model in the way behaviours are defined and interact with the state machine/planner. Each state is typically associated with a behaviour. When the state machine moves to a new state, the corresponding behaviour is activated. Behaviours are

implemented as ROS nodes and execute independently of the state machine, such that the latter at each time step can decide to change state or stop execution. This is particularly important when implementing user interfaces and also error handling.

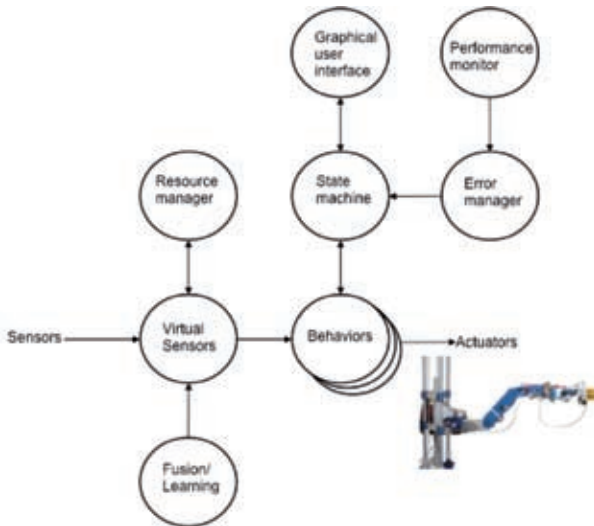

Figure 1. Hybrid architecture for the developed framework.

The Graphical user interface contains controls to start, pause, and stop the state machine. It also displays informative messages retrieved from the behaviours and other modules. A Virtual sensor is an abstraction of a regular sensor, and connects to one or several physical or virtual sensors. The Resource manager provides customization of the virtual sensors such that the system can be adapted to varying environmental conditions. At present, this kind of customization is done off-line and stored in configuration files that are read at system initialization.

Errors are dealt with at two levels in the system. Some errors are both detected and dealt with locally where the problem appears. One example is if a node responsible for fruit localization is not able to find any fruit in the image. The node may deal with this by acquiring a new picture and trying again, moving the camera or platform, or calling for human assistance. Other errors are independent of the current state, and are preferable detected and



dealt with at system level, by the Performance monitor and the Error manager. One example is a camera that suddenly stops functioning. This may be detected by the Performance monitor and forwarded to Error manager, which then stops the state machine and prints an error message through the GUI.

### 3. Results and conclusions

We have presented results from on-going development of a software framework for agricultural robots. The architecture is described from several views; Logical, Development, Process, and Physical. This way of describing a system displays complementary information that is not easily given in a single architecture view. This supports decisions in the design phase and enables a more successful end result.

The developed framework uses a state machine as replacement for the planner commonly found in other hybrid architectures. When applied to the development of a specific robot, the state machine is programmed to implement a flow diagram describing the top-level behaviour of the robot. The framework will be further developed and used when integrating work by the fourteen partners in the CROPS project.

### Acknowledgements

*This work is partly funded by the European Commission (CROPS GA no 246252). Thanks to Peter Hohnloser for implementing the state machine used in the robot architecture.*

### References

- Baur J, Pfaff J, Ulbrich H, Villgrattner T (2012) *Design and development of a redundant modular multipurpose agricultural manipulator*, submitted to IEEE/ASME International Conference on Advanced Intelligent Mechatronics, July 2012
- International Organization for Standardization (2007) *ISO/IEC 42010:2007 Systems and software engineering - Recommended practice for architectural description of software-intensive systems*, ISO/IEC 42010 IEEE Std 14712000 First edition 20070715, International Organization for Standardization, available at <http://ieeexplore.ieee.org>
- Kruchten P (1995) *Architectural Blueprints - The "4+1" View Model of Software Architecture*, IEEE Software, Vol. 12, No. 6. (November 1995), pp. 42-50
- Matarić M J (2002) *Situated Robotics*, invited contribution to the Encyclopedia of Cognitive Science, Nature Publishing Group, Macmillan Reference Limited
- Quigley M, Gerkey B, Conley K, Faust J, Foote T, Leibs J, Eric Berger RW, Ng A (2009) *ROS: An Open-Source Robot Operating System*, In ICRA Open-Source Software workshop



TOPIC n° 2.1

**Development of a multipurpose agricultural manipulator**

**Julian Pfaff, Joerg Baur, Heinz Ulbrich<sup>1</sup> and  
Thomas Villgrattner<sup>2</sup>**

<sup>1</sup>*Institute of Applied Mechanics, Technische Universität München, 85748 Garching,  
Germany, {pfaff, baur, ulbrich }@amm.mw.tum.de*

<sup>2</sup>*KUKA Laboratories GmbH, 86165 Augsburg, Germany,  
thomas.villgrattner@mytum.de*

**Keywords:** design of manipulators, redundant robots, modular, robotics in agriculture

---

**Abstract:**

Nowadays, agriculture is more and more governed by machines. They often facilitate the demanding and exhausting work and increase the harvesting efficiency. However, for selective harvesting as well as in greenhouse horticulture where the conditions of work are very demanding, due to the limited workspace, the high humidity and temperature, up to now, there are very few autonomous systems to support humans. Thus, in this paper a multipurpose agricultural manipulator, which allows adaption to different tasks and crop, is introduced. Based on the requirements arising from present conditions in field and greenhouses a concept with nine degrees of freedom is acquired. A dynamic simulation model is applied for system design and evaluation. The links are evaluated with FEM-analysis to guarantee a stiff but lightweight construction. Finally a prototype of the designed system was set-up, proving in first field tests the suitability of the investigated approach.

---

**1. Introduction**

In the last decades, automation of agricultural tasks is increasing. Employing machines for the often exhausting duties allows unburdening workers and reducing their labor hours. Therefore



production costs for sweet-pepper can be decreased, which are caused to one third by wages, see (Vermeulen, 2008).

Bulk harvesting systems, e.g. for grapes (Pari et al., 2009), guarantee high output capacities. However, growers use them mostly for low quality crop only. High value crop are harvested one by one. Approaches based on standard industrial robots, like (Baeten et al., 2008), or custom made manipulators, e.g. (Kitamura, 2005), are commonly designed for one single crop or duty only. By changing the end-effectors, the system presented in (Monta et al., 1995) can be adapted to different duties in grape cultivation. However, neither the workspace nor the manipulator configuration can be changed.

In this paper the development of a multipurpose agricultural manipulator is introduced. The system can be adapted to different crop and duties by changing the workspace, the configuration, and the end-effectors. To increase the grower's acceptance, their cultivation alignment must be maintained unchanged as much as possible.

## **2. Design**

This section describes the design process from the requirements through to the implementation of the acquired concept.

### ***2.1. Requirements***

The investigated manipulator will be used for the harvesting of sweet-pepper, apples, and grapes as well as for spraying. The requirements are mainly based on the harvesting of sweet-pepper, since they are the most challenging. A simplified overview of a sweet pepper row in a greenhouse is shown in Fig. 1. The area marked with a bold black line is the available workspace. It will be provided by slightly moving the depicted three plants. To achieve a high manipulability next to the fruit the supposed direction of picking is in line of fruit and stem, which all in all leads to the concept described in Section 2.2. The structure is introduced in Fig. 2. For further information refer to Baur et al., 2012.

Principally, the dimensioning of the manipulator and its drives is based on three criterions. On the one hand the cycle time for harvesting one sweet pepper should not exceed six seconds. This means, that under assumption of two seconds for the gripping and cutting part, one way (to/off the fruit) must be covered in less than two seconds. On the other hand, the payload including the gripping/cutting tool and the fruit was appointed to 4kg. The resulting forces, respectively the required torques and speeds based on these specifications were calculated in a dynamic simulation (Section 3.1).

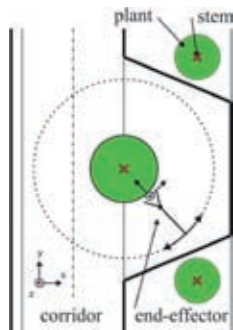

Fig. 1: Top view of the available workspace

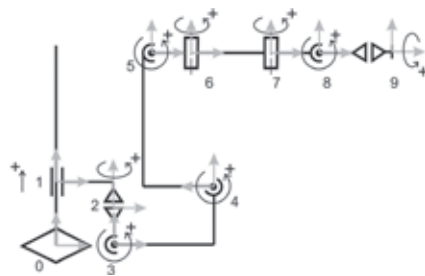

Fig. 2: Concept of the manipulator with nine degrees of freedom (DOF)

Another important requirement is the claimed accuracy of the end-effector movement, which should be in the range of 1cm.

## 2.2. Concept

The investigated manipulator has one prismatic joint enabling large vertical movement and eight revolute joints for the motion around the plant. Due to the redundancy and the high dexterity the manipulator should be able to reach all fruits while avoiding obstacles at the same time.

The adaptation to different tasks respectively fruits is enabled with the modular design approach. All in all there are four interfaces where the kinematics and the workspace can be adjusted. The exchange of the linear bearings of joint 1 allows a reconfiguration of the height of the working space. The interfaces between joint 3 and 4 as well as between 6 and 7 can either be used to change the link lengths, to reduce the DOFs by omitting





links, or to directly mount an end-effector. Finally the mounting point on joint 9 can be used for sundry end-effectors.

### 2.3. Implementation

One major point by implementing the concept is the trade-off between actuating power and weight. To reduce the systems inertia and thereby reducing the needed power, the actuators were separated from the actual gear and moved as close as possible to the base frame. Additionally, to the improved weight balance, there evolve another two advantages. In the first place, the arm gets a lot smaller, because drive and gear do not have to be in-line. And secondly there is a supplementary reduction ratio by connecting motor and gear via a belt drive, which is needed due to the properties of the used brushless DC motors. The good power to weight ratio of the utilized motors namely comes along with high speeds but low torques. To achieve the aimed accuracy in conjunction with the high reduction ratio Harmonic Drives were used as gears. Exemplary, the assembly of one link, connecting joint three and four, is shown in Fig. 3. The motor controllers are mounted next to the appending motors. The outcome of this decentralized system is a considerable reduction of cabling.

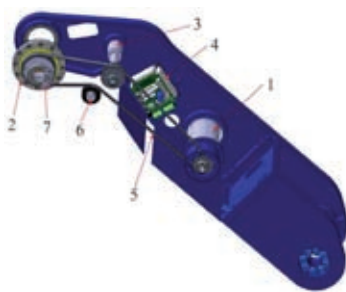

- 1 Motor with Encoder
- 2 Harmonic Drive
- 3 Brake
- 4 Motor controller
- 5 Belt Drive
- 6 Tension Roll
- 7 Limit Switches

Fig. 3: Detailed assembly of element 4

### 3. Simulation

To investigate and optimize the behavior of the designed manipulator, different simulations were carried out for the mechatronic design.

### 3.1. Dynamical Simulation

The manipulator was modeled as a multi body system with rigid segments using the Newton-Euler equations, resulting in the equations of motion:

$$\mathbf{M}(\mathbf{q})\ddot{\mathbf{q}} + \mathbf{h}(\mathbf{q}, \dot{\mathbf{q}}) = \mathbf{Q}.$$

With the mass matrix  $\mathbf{M}$ , the vector  $\mathbf{h}$  containing the coriolis, centrifugal and gravitational forces and  $\mathbf{Q}$  describing the motor torques. For detailed information see Baur et al., 2012.

### 3.2. FEM

On the basis of the forces and torques calculated in Section 3.1, every link was simulated in a FEM analysis. According to the results the links were redesigned and optimized. Particular attention was dedicated to the minimization of the displacements. Else, contemplating the stretched arm, where the displacements are accumulated, the accuracy would decrease considerably. Using the example of link 4, with a load of 25Nm and 100N on the upper left side while being fixed on the lower right side there occur von Mises-Stresses (Fig. 4) and Displacements (Fig. 5) of up to 25 MPa and 0,331 mm, respectively.

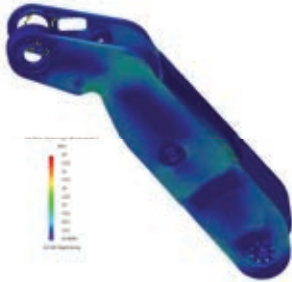

Fig. 4: Von Mises-Stresses of link 4

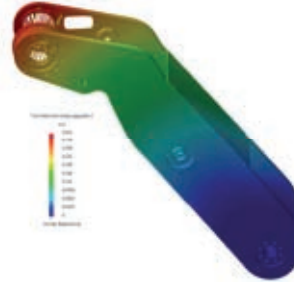

Fig. 5: Displacements of link 4

## 4. Results and Conclusion

Based on design and simulation the manipulator was manufactured and assembled (Fig. 6). First tests showed the suitability of the concept in field conditions (Fig. 7, Gripper provided from Festo AG & Co. KG as Project partner for gripper development). Further tests in different field conditions will follow, and the findings will be integrated in a next generation of prototype.



As an automatic calibration is currently under investigation, the arm was calibrated manually. With this, the accuracy, as far as we tested, already fulfills the required constraints.

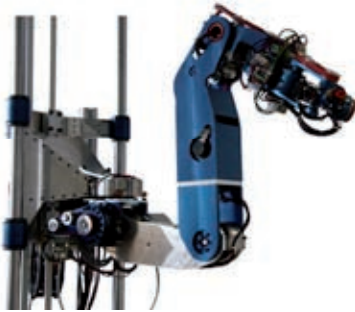

Fig. 6: Prototype of manipulator



Fig. 7: Field test

The next field tests include the harvesting of different crop, especially apples. Therefore the exchangeable link lengths will be optimized and adapted.

### Acknowledgements

*The work presented in this paper is partly funded by the European Commission in the 7<sup>th</sup> Framework Programme (CROPS GA no 246252). Special thanks go to G. Mayr, S. Gerer and P. Schneider for their technical support and contributions to the electrical and mechanical design.*

### References

- P. C. M. Vermeulen, "Kwantitatieve informatie voor de glastuinbouw (quantitative information for horticulture)," Wageningen UR Greenhouse Horticulture, Wageningen, The Netherlands, Tech. Rep., 2008, (in Dutch).
- L. Pari, F. Pezzi (2009): *Evaluation of Two grapes Harvesting Machine with Horizontal and Vertical Shaking*. In 2009. CIGR Proceedings, Technology and Management to Increase the Efficiency in Sustainable Agricultural Systems, pp. 1-5.
- Baeten, J.; Donné, K.; Boedrij, S.; Beckers, W.; Claesen, E. (2008): *Autonomous Fruit Picking Machine: A Robotic Apple Harvester*. In Christian Laugier, Roland Siegwart (Eds.): *Field and Service Robotics*. Berlin, Heidelberg: Springer Berlin Heidelberg, pp. 531–539.
- Kitamura, S.; Oka, K. (2005): *Recognition and cutting system of sweet pepper for picking robot in greenhouse horticulture*. In 2005 IEEE International Conference Mechatronics and Automation 4, pp. 1807–1812.
- Monta, M.; Kondo, N.; Shibano, Y. (1995): *Agricultural robot in grape production system*. In 1995. Proceedings. Robotics and Automation 3, pp. 2504–2509.
- Baur, J.; Pfaff, J.; Ulbrich, H.; Villgrattner, T. (2012): *Design and development of a redundant modular multipurpose agricultural manipulator*. Accepted for IEEE/ASME International Conference on Advanced Intelligent Mechatronics, July 2012



TOPIC n° 2.1

Evaluation of field test of harvesting system for picking  
dates fruits based on robotic arm

Abdulrhman Al-Janobi<sup>1</sup>, Abdulwahed Aboukarima<sup>2</sup>

<sup>1</sup>*College of Agriculture and Food Sciences, Department of Agricultural Engineering,  
King Saud University, P.Box 2460, Riyadh 11451, Saudi Arabia (e-mail:  
janobi@ksu.edu.sa)*

<sup>2</sup>*AgricultureResearch Centre, Agricultural Engineering Research Institute, Egypt (e-  
mail: aboukarima@gmail.com)*

Keywords: robotic arm, agriculture, palm tree, harvesting

**Abstract:** In this research, evaluation of field test of harvesting system for picking dates fruits based on robotic arm was investigated. The idea was to carry an industrial robotic arm by a hydraulic telescopic machine to reach the dates on the tree. The laboratory tests for determining the shear forces to cut date bunches was studied and it was ranged from 122 to 315 N based on the speed of shear and moisture content of the bunches. The bunch cutter unit was fixed on the robotic arm to work as one unit during harvesting. Field experiments were carried out, and the harvesting times were recorded until the completion of harvesting tree. The results showed that the developed system could complete the harvest of a palm tree having 5 bunches within 6 minutes with field efficiency of about 41%.

## 1. Introduction

Saudi Arabia has realized early the importance of dates as a national strategic product. It realized their nutritional and economic values in achieving food security. Thus, the Kingdom has promoted several programs to boost investment in the field of dates production and processing. The area planted with palm trees has augmented as a result. The scientific research in Kingdom targeting palm trees and dates processing has shown a



growing concern towards enhancing the performance of agricultural equipment dealing with palm trees.

It has been also keen on increasing the productivity, improving the quality, cutting down manpower and minimizing costs of production. Upgrading the efficiency of equipment can be fulfilled by means of remodelling in order to get the utmost outcome.

Ibrahim et al. (2007) have pointed out that 45% of the total production cost is spent in dates harvesting. They also held out that this high cost is what made scientists think of mechanizing dates harvesting. Manual harvesting of dates from selected bunches is an utterly expensive (Loghavi and Abounajmi, 2001). It is also a time-consuming process. Let aside that it requires skilled labour that receive high wages. Al-Janobi (1999) outlined that four elements should be present while designing future palm trees service devices: equilibrium, maneuverability, safety and economical costs. He again pointed out (Al-Janobi, 2001) that almost all the existing palm trees services systems are concerned with only lifting the labourer to the bunch to carry out certain missions.

Agriculture development cannot be maintained without the introduction of new machinery that backs up production (Blackmore et al., 2007). In this connection, robots seem to be a potential substitute to labour in so far harvesting process is concerned (Feng et al., 2008). Grift (2007) has underlined that in agriculture there is a growing incentive need to utilize the robotic technology to cut down manpower, improve quality control of the products, and settle down the problematic issues related to seasonal crops harvest. Robot is a machine that can be programmed to carry out certain tasks. In spite of the spreading-out of robots in many fields like industrial applications, its usage in the field of agriculture is still limited.

Robotics can help extensively in this respect. The existing technologies pave the way to a lot more in the field of automation. It is predictable that they will be used on a large scale. The purpose of this research work was to evaluate under

field conditions a harvesting system for picking dates fruits based on robotic arm.

## 2. Materials and Methods

### *2.1 Studying bunch position on a palm tree*

A field study was conducted around the time of complete growth of the bunch, (i.e.) the commencement of colorization. Attention was given to the choice palm trees of different ages ranging from 8 to 15 years. Common types of palm trees around Riyadh area in Saudi Arabia were elected, namely: Khoudary, Khalas, Sukkari and Nabout Seif. Fig. (1) shows the bunch positions on a palm tree that have been examined. These measures helped in determining the diameter for the operation of the robotic arm. The laboratory test for determining the shear forces to cut date bunches was studied and it was ranged from the 122 to 315 N based on the speed of shear and moisture content of the date branches.



Fig. 1 .Bunche positions on a palm tree.

### *2.2 Automated machine for hoisting the arm to the level of the palm tree*

A telescopic machine was selected. Its type is "caterpillar (TH62) Telehandlers. It was selected due to its easy to hoist the robotic arm quickly and accurately to the harvesting spots without suffering any sort of imbalance. However, telescopic machines have proved useful in this respect as they enjoy lots of merits. One important advantage additional to equilibrium is high maneuverability. The robotic arm was fixed on an iron platform  $90 \times 35 \times 1$  cm (height, width, thickness). The bunch cutter unit was installed on the robotic arm. An AM100IC type



robotic arm, produced by FANUC Company was selected to be the main element in the harvesting unit. This arm functions in a diameter of 142 cm. It can rotate 360 degrees. It is capable of holding up to 5 kg. It contains 6 axis that enable it to revolve in directions X, Y and Z.

### *2.2 Field experiment and calculations*

The whole unit was called Mobile Robot Unit for Dates Harvesting (MRUDH). MRDDH was operated in the field to know its capability to reach dates and harvest them. The field experiment was conducted in Huraimla Governorate, Saudi Arabia which is located about 90 km to the north-east of Riyadh, the capital of Saudi Arabia. It lies 820 meter above sea-level. After calibrating and fixing the robotic arm and making sure that all control guards and connections are in place, the unit was moved to a palm tree. Levers then were operated to hoist the robotic arm in the direction of a bunch. The robotic arm was manipulated by a person on the ground by grace and means of a remote control and sensing unit.

The different times while harvesting a palm tree by MRUDH were addressed. Each bunch was handled separately. An electronic balance was used to weigh the dropping dates onto the date collection unit.

### **3. Results and conclusion**

At first, the Telehandlers was operated in the field to record boom up and boom down times without the robotic arm installed on it. The results indicated time was ranged between 4 s to 11 s. Table (1) indicates the field efficiency and the productivity of MRUDH system for harvesting a single palm tree that extends to 5.3 m and carry some bunches four of which were harvested. It was discovered that the field efficiency was low because the bunch harvesting time was higher when compared to other times. It was found out that productivity reached 261 kg of dates/hr. Performing a simple analysis, we found that the average time spent for harvesting a single palm tree is 343 s or about 6 minutes. If we assume that the average of date weight on



a single palm tree is 40 kg and that the daily average manual harvesting is 80 palm trees (10 hrs work scheme), then 8 palm trees can be harvested per hour.

Table 1. Field efficiency and productivity during bunch harvesting cycle with MRUDH

Bunche No	Harvested date weight (g)	Field efficiency (%)	Productivity (kg /s)
1	6251		
2	7214		
3	6214		
4	5214		
Total	24893	41	0.0726

When we draw a comparison between this system and other methods that harvest one palm tree in 22 minutes according to (Shamsi, 1998) then it becomes apparent that the developed system was faster, more economical and more productive. Certain conclusions have been concluded from this study. They can be summed as follows:

-The robotic arm was installed, calibrated and operated without obstacles or hindrances. Testing had proved that it could reach the bunch, surmount it and function properly and smoothly in all directions and around the bunches .No shaking has been noted that can seriously affect the precision performance of the system.

#### Acknowledgment

*The researchers would like to express their gratitude and appreciation for King Abdel-Aziz City for Science and Technology for funding the project No. MT-1-3 under the title of "Semi Automated Harvesting Dates Trees Based on Robotic Arm".*

#### References

- Al-Janobi A. (1999). *Theories on palm tee services machine*. 6<sup>th</sup> symposium , Arab-Italian Workshop on Agricultural mechanization, Pologne, Italy, 15-16 November 1999.



- Al-Janobi A. (2001) *A date palm service machine for the new Millennium*. The 2<sup>nd</sup> International Conference on Date Palms, Al-Ain, United Arab Emirates 25-27 March 2007.
- Blackmore B.S., H. Griepentrog, S. Fountas and T. Gemtos (2007). *A specification for an autonomous crop production mechanization system*. Agricultural Engineering International: the CIGR Ejournal. Manuscript PM 06 032. Vol. IX. September, 2007.
- Feng G., C. Qixin and N. Masateru (2008). *Fruit detachment and classification method for strawberry harvesting robot*. *International Journal of Advanced Robotic Systems*, 5, 41-48.
- Grift T.E. (2007). *Robotics in crop production*. Encyclopedia of Agricultural, Food and Biological Engineering, doi: 10.1081/E-EAFE-120043046.
- Ibrahim A.A., H. R. Ibrahim and N. Abdul\_Rasool (2007). *Development and testing of a shaker-system for the selective SHS*. Acta Horticulture 736 III International Date Palm Conference, Volumes 1, Abu Dhabi, United Arab Emirates, 31 March 2007.
- Loghavi M., M. Abounajmi (2001). *Effects of shaking mode, frequency and amplitude on 'Shahani' date fruit detachment. I: Design and development of an experimental shaker*. *Iran Agricultural Research*, 20,121-138.
- Shamsi M. (1998). *Design and development of a tree climbing date harvesting machine*. Unpublished PhD Thesis, Silsoe College, Cranfield University.UK.



## TOPIC n° 2.1

### **Vision system based on RGB filter to guide autonomous vehicles in greenhouses**

**Victoria Plaza<sup>1</sup>, Francisco Rodríguez<sup>1</sup>, Ramón González<sup>1</sup>**

<sup>1</sup>*Agrifood Campus of International Excellence (ceiA3), University of Almería, Ctra. Sacramento s/n, La Cañada de San Urbano, 04120, Almería. Spain (e-mail: plv834@ual.es, frrodrig@ual.es, rgonzalez@ual.es)*

**Keywords:** Ground mobile machines, Computer vision for guidance, laser guiding system, autonomous navigation

---

**Abstract:** This paper presents a vision system based on an RGB filter for guiding purposes of mobile robots working in greenhouses. In particular, vision is used to detect a set of lasers installed in the greenhouse corridors marking a desired route. This guiding system can be easily adapted to other autonomous vehicles easily. Furthermore, it constitutes a low-cost solution compared to other guidance systems appeared in the literature. Physical experiments validating the proposed vision approach are shown. In this sense the main contribution of this work comes from a practical point of view rather than from a theoretical one.

---

## **1. Introduction**

Autonomous vehicles working in greenhouses make possible to replace workers on tedious and dangerous tasks. In addition, they provide consistency and accuracy in tasks such as harvesting and spraying. This paper is related to the navigation problem of mobile robots operating in greenhouses. It constitutes an attractive research field, but a whole successful answer has not been found yet. Although there are some projects with promising results (Gonzalez et al., 2009; Mandow et al., 1996; Sammons et al., 2005; van Henten et al., 2002), but they present some drawbacks mainly related to the localization



strategy (error growth effect of odometry based solutions, poor accuracy of beacons solutions, etc.).

## **2. Materials and methods**

### ***2.1. Inversos robot***

This paper is framed in a project which proposes, among others, the implementation of a multi-purpose automatic movement system inside the greenhouses, which can be used for various tasks such as phytosanitary treatments, transportation, collection, transport of workers, etc. In this context, we are presenting the *Inversos* vehicle (Fig. 1). It has a locomotion system composed of a double crown for the rotation and traction of the front and rear wheels, powered by electric motors (900 [W]), and reaching a top speed of 1.5 [m/s]. Currently a spray system (400 [l] phytosanitary tank) and a scissor lift have been developed to be attached to the chassis. The vehicle incorporates a system based on PC-104 architecture for control purposes. The vehicle includes a switch that allows manual or autonomous control.

### ***2.2. Laser system***

On the front of the vehicle a structure with three dartboards has been installed (see Fig. 2), one on the front part and two on each side. On top of this structure there are three cameras pointing at every dartboard and are connected to the PC. The vehicle dartboards have a size enough to capture the incidence of the laser from any valid position of the vehicle within a greenhouse corridor. The dartboard has a front width of 0.19 [m], which is the difference between the corridor width and the vehicle width. A dark colour is needed for the dartboards and a matt material lining the entire interior of the structure (in this project black cardboard is used) in order to avoid reflections of the structure that would cause errors in detection. These dartboards will be hit by laser emitters.

Tests were conducted in the greenhouse for checking the performance of different kind of laser emitters. Infrared lasers incidence was measured by various types of photodetectors with

no positive results in the greenhouse, but the results of red and green laser were positive. In fact, laser emitter requirements are: red laser since it has a lower cost; maximum output power 5mW because it is in balance between safety standards (UNE-EN 60825-1/A-11) and the visibility at long distances; focal capacity adjustable to concentrate the beam for long distances properly. In this work the LTG model is used which has a wavelength of 650 [nm].

### **2.3 Guiding approach**

The guiding system proposed for *Inversos* robot requires the installation of a lasers mesh in the greenhouse corridors. The laser-based guiding system architecture is shown in Fig. 3. The operator can select a desired route goal: minimum route between the origin and destination point of the vehicle, route through all the intermediates corridors and a manual route. Then the road management module plans the route, selects the set of laser emitters to be switched on. It activates only two lasers at each moment depending on the current robot position. This module communicates with a controller via a wireless link. *Inversos* greenhouse controller is an industrial communication module *NI Compact FieldPoint* which through a field bus turns on/off the laser emitters. The laser emits a beam of light along the longitudinal axis of each corridor of the greenhouse, so that the beam hits over the vehicle dartboards, tracing the path to follow. The vehicle follows the path traced by the laser emitters using a vision-based and pseudo-reactive navigation algorithm and three built-in cameras.

The vision algorithm consists of a loop where at each iteration performs the processing of the acquired image from the front camera and an image of one of the two side cameras. The navigation control module sends the appropriate commands to the motion controller based on the detection of the laser: moves forward, forward but correcting the trajectory, or turn to a new corridor. In order to obtain failure tolerance three conditions have been considered which stop the vehicle: emergency manual button, front collision (touch sensor or sonar), and no tracking



laser is detected (an obstacle or human worker obstructs the laser beam).

#### **2.4. Vision system**

The goal of the vision system is to determine if there is a laser incidence on the dartboard or not, and if so the trajectory error, what is the distance between the beam and the centre of the dartboard, is calculated.

From the hardware point of view, it uses three *Logitech Quickcam Sphere AF* camera units; this webcam constitutes a low-cost and a PC-104 compatible (USB 2.0) solution. Furthermore, it has a small size which fixes properly within the dartboards. Other features: resolution 2-megapixel sensor, 24-bit true colour, frame rate up to 30 frames per second.

On the other hand, the software implementation follows four stages:

- 1) Acquisition of the dartboard colour image from the camera each 0.6 second. Due to this high computation time, the speed in the vehicle has been bounded to 0.13 [m/s].
- 2) Pre-processing: to discard from the image the area around the dartboard. It consists of applying a mask previously known, thus discarding the entire area of the image that does not correspond to the dartboard. In this way, errors due to reflections are avoided.
- 3) Segmentation: to make a threshold process that consists of generating a black and white image where the laser beam is the region of interest and will be white and the rest black. It produces an image where a white circle appears (the beam) on a black background. The histograms of the three channels of the laser images must be previously analyzed in order to determine the limits of the colour that the laser beams occupy. Note that we have checked the HSL (Hue, Saturation, Lightness) colour model and RGB colour model, the best results were obtained with the second approach.
- 4) Representation and Description: if no white object is detected, then the laser is not detected. But if an object is got,

then the centre of the point is calculated (representing a single pixel). After that, using the calibration parameters, the actual distance (in centimetres) from the centre of the dartboard is calculated. Note that such deviation is only calculated for the x-axis (lateral deviation).

### **3. Results and discussion**

The detection of the laser beam and the calculation of the distance from the centre of the dartboard were tested for various light conditions. The colour of the laser on the dartboard in a greenhouse environment (Fig. 4a) is white, so its RGB histogram is between the previously defined limits of the threshold filter. In the case of direct sunlight condition (open environment), the laser beam is pink so its RGB histogram is outside the range of the threshold filter. Note that these extreme conditions of luminosity, rarely found in real greenhouses, led to wrong results following the RGB filter approach proposed (Fig. 4b). For future works, we are thinking about using a template matching approach to improve the current vision algorithm.

Finally the road management system permits to plan any route between the crop lanes and to manage the activation and deactivation of lasers when the vehicle passed through the corridors of the route.

In conclusion, the proposed guiding system has some advantages over other systems because it allows flexibility for each execution path. Furthermore it has neither problem with the location accuracy nor requires expensive and rigid structures in the greenhouse. It is independent of the crop growth, except if it obstructs the laser beam.

### **Acknowledgements**

*The authors thank the Andalusian Technology Commission for supporting the project "Inversos: Improvement in Efficiency in Greenhouse Vegetable Production in Semi-arid Climate" (Reference no. 400674). Special mention deserves the Experimental Station "Las Palmerillas" of Cajamar for leasing its facilities.*





## References

- R. González, F. Rodríguez, J. Sánchez-Hermosilla, and J. Donaire, *Navigation Techniques for Mobile Robots in Greenhouses*, Applied Engineering in Agriculture, Vol.25, no.2, 153-165, 2009.
- A. Mandow, J.M. Gómez-de-Gabriel, J.L. Martínez, V.F. Muñoz, A. Ollero, A. García-Cerezo, *The Autonomous Mobile Robot Aurora for Greenhouse Operation*, IEEE Robotics and Automation Magazine, Vol. 3(4):18- 28, 1996.
- P. J. Sammons, F. Tomonari, A. Bulgin, *Autonomous pesticide spraying robot for use in a greenhouse*, Australian Conference on Robotics and Automation, 2005, Sydney, Australia.
- E. J. Van Henten, J. Hemming, B. A. J. Van Juijl, J. G. Kornet, J. Meuleman, J. Bontsema, E. A. Van Os, *An autonomous robot for harvesting cucumbers in greenhouses*, Autonomous robots Vol. 13, 241-258, 2002.



Figure 1. Inversos vehicle

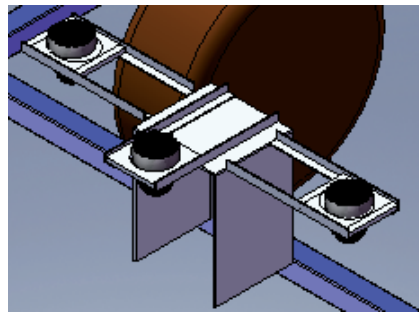

Figure 2. Dartboards structure

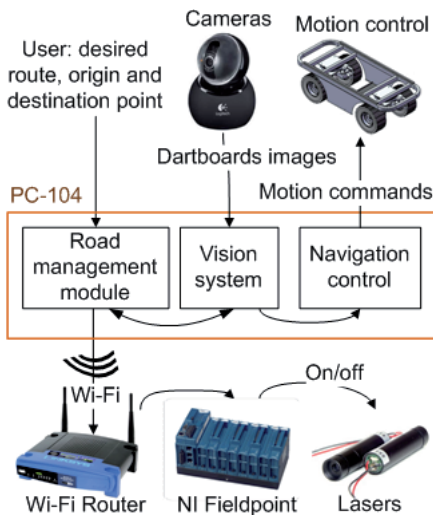

Figure 3. Architecture of the laser-based guiding system

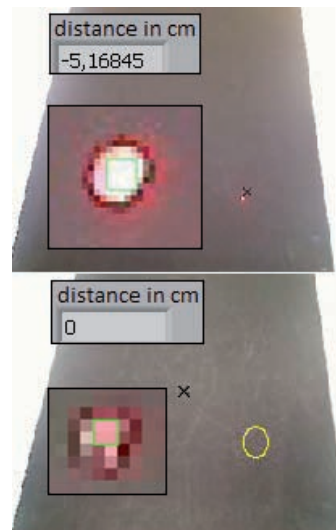

Figure 4. Vision tests (a) in the greenhouse and (b) with direct light over the dartboard

**Session 3:**  
Sensorial systems for agriculture





TOPIC n° 2.1

Evaluating the performance of a low-cost GPS in precision  
agriculture applications

Kjeld Jensen<sup>1</sup>, Morten Larsen<sup>1</sup>, Tom Simonsen<sup>2</sup>, Rasmus N.  
Jørgensen<sup>1</sup>

<sup>1</sup>*Institute of Chemical Engineering, Biotechnology and Environmental Technology,  
University of Southern Denmark, Campusvej 55, 5230 Odense M, Denmark*

<sup>2</sup>*Compleks Innovation ApS, BusinessPark Struer, Fælledvej 17, DK-7600 Struer*

**Keywords:** precision agriculture, gps, field robot

---

**Abstract:** Field Robots are often equipped with a Real Time Kinematic (RTK) GPS to obtain precise positioning. In many precision agriculture applications, however, the robot operates in semi-structured environments like orchards and row crops, where local sensors such as computer vision and laser range scanners can produce accurate positioning relative to the crops. GPS is then primarily needed for robust inter-row navigation.

This work evaluates a new low-cost GPS. Static tests were used to test the absolute accuracy. To test the GPS in a precision agriculture environment it was installed on a robot driving in a simulated row crop field. The GPS supports raw data output as well and similar experiments were performed to evaluate the GPS when used in a RTK setup.

In field tests more than 95% of position errors were estimated to be within 2.6 m. In RTK field tests more than 95% of measurement errors were estimated to be within 0.2 m. It was concluded that the GPS can be applied to selected row crops and orchards applications if augmented by local sensors and mapping techniques. Using the module in a RTK setup applies to general applications where position errors of 0.2 m are acceptable.



## 1. Introduction

Field robots often use a Global Positioning System (GPS) based on Real Time Kinematic (RTK) for precise navigation. However in a typical agricultural environment there are areas where trees, buildings, power lines etc. may shade or reflect the satellite signals. This causes temporary drops in positioning accuracy, and some means of dead reckoning system is therefore needed as well. RTK equipment retails at USD 15,000 to 60,000 and significantly increases the cost of field robots (Grisso et al., 2009).

In precision agriculture the robot often operates in semi-structured environments like orchards and row crops where local sensors like computer vision and laser range scanners can produce accurate positioning relative to the crops. GPS is then primarily needed for inter-row navigation and mapping, and inaccuracies at the order up to a few meters may be acceptable in some applications.

Recently a new low cost GPS has been introduced. At a retail price of USD 180 the specifications claim an increased accuracy in static and slow moving applications. It supports raw data output as well, which allows use in RTK setups using an external computation library. It is hypothesized that this GPS is useful in some precision agriculture applications in semi-structured environments, and the aim of this work is to evaluate the GPS performance with respect to those applications.

## 2. Materials and methods

In this work a u-blox NEO-6P GPS engineering sample was evaluated. For RTK two LEA-6T GPS were used since the engineering sample did not have raw data output. u-blox has confirmed that the engineering sample algorithms are identical with the current version and that the raw data available on the NEO-6P is equal to that on the LEA-6T.

To test the NEO-6P a prototype board was designed and linux software was written to configure the NEO-6P. In all tests the NEO-6P was connected to a GNSSA200 antenna from Gutec

AB. In RTK tests the LEA-6T were connected to Trimble Patch antennas, and the RTKLIB v2.4.1 (Takasu and Jasuda, 2010) was used for precise positioning. Post-processing was performed using Python.

### 3. Results and conclusions

#### 3.1 Static tests

These tests evaluate the absolute accuracy during variations in the satellite constellation and atmospheric disturbances. The antenna was installed at a location with no significant obstacles above the NEO-6P default elevation mask of 5 degrees. The position of the antenna was estimated by averaging RTK fixed solution measurements using a DataGrid MK3 receiver and is assumed to be exact. A GPS antenna signal splitter was constructed to split the signal between the NEO-6P and a Garmin GPS60 receiver. Fig.1 (left) shows the results of a 95 hour test with the NEO-6P configured for 5 Hz output rate. 99% of the outputs returned DGPS fix indicating that SBAS was used to improve the positioning quality. 95% of the measurement errors were within 1.98 m. For the Garmin GPS60 95% of the measurement errors were within 2.60 m. A number of tests were performed with similar outcome.

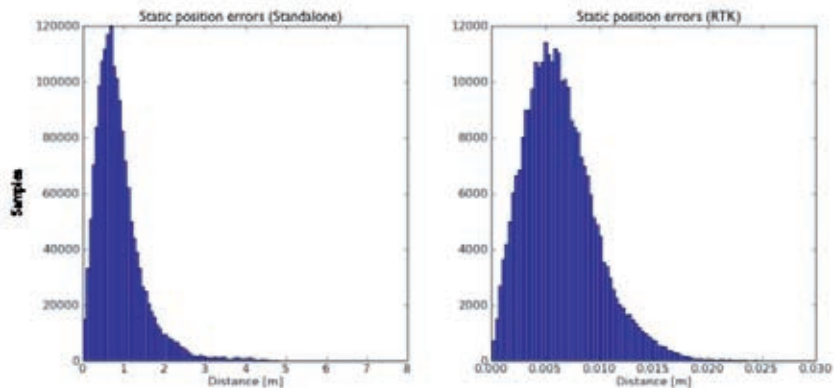

Fig.1. Static tests

In the RTK test a LEA-6T was configured to output raw data at 5 Hz, and a PC with RTKLIB performed the precise position



estimation. Another LEA-6T with same configuration was used as reference station less than 50 meters away. Fig.1 (right) shows the results of an 8 hour test where 95% of the measurement errors were within 0.013 m. 0.12% of the measurements with an error less than 0.75 m has been excluded from the histogram.

### 3.2 Field tests

These tests evaluate the performance in a precision agriculture scenario. A route that simulates driving in row crops was laid out on a 15x15 m grass field using an inter-row spacing of 3 m. Close to the grass field were scattered groups of trees and a barn. The NEO-6P was installed on an Armadillo field robot. A Topcon GRS-1 unit was used to collect reference data which is assumed to be exact. The route was driven three times with 8 and 3 hours between. Only in test 3 did the NEO-6P report DGPS quality in 14% of the position outputs. Fig. 2 (left) shows the result of test 3 which had the largest deviation from the reference track. The black line is the GRS-1 reference track and the green line is the NEO-6P track. The NEO-6P antenna location 0.3 m in front of the GRS-1 reference antenna has not been compensated due to lack of accurate yaw angle estimation. In all tests more than 95% of the measurement errors were estimated to be within 2.6 m.

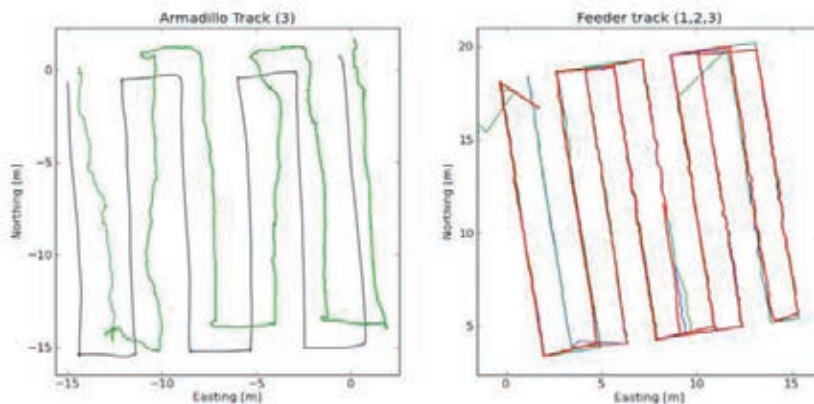

Fig.2. Field test results



In the RTK test a route was laid out on a 15x15 m grass field using an inter-row spacing of 1.5 m. Close to the grass field were one storey buildings. The vehicle used for this test is a diesel-driven feeder driving at 0.25 m/s. The LEA-6T setup is the same as described in the static RTK test. The route was driven three times with 25 and 1 hours between. The lateral driving accuracy is estimated to be within  $\pm 5$  cm. Fig.2 (right) shows the resulting tracks measured by the LEA-6T and filtered to exclude the headland turns. Row 6 from the left seems to be affected by a convergence error in the southern end. This may have been caused by signal blocking or multipath conditions caused by buildings just south of the track. The offset between the three individual tests in this worst case situation shows an estimated accuracy of approx.  $\pm 0.2$  m.

In order to improve the state estimation accuracy and reliability an Extended Kalman Filter (EKF) (Larsen 1998) was created. Odometry from the Armadillo motor hall sensors was used as system input and the NEO-6P positions as measurement updates. The NEO-6P gave quite scattered position outputs in the field test 2 so data from this test was used for evaluation.

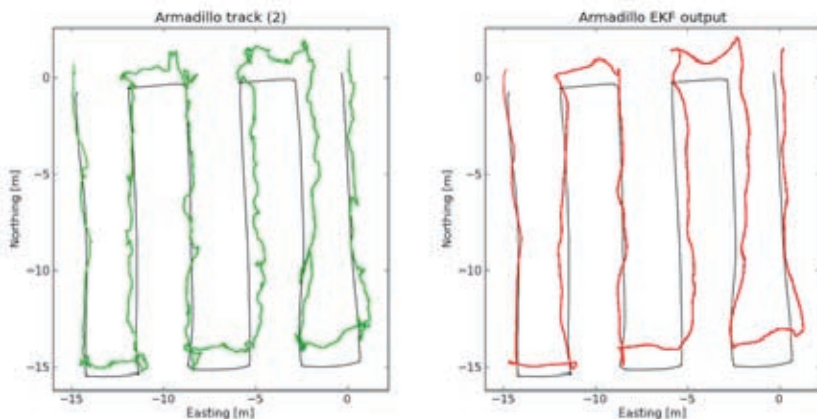

Fig.3. Armadillo track and EKF output

Fig.3. shows the result. The black line is the GRS-1 reference track, (left) is the NEO-6P track and (right) is the EKF state



estimate. The NEO-6P antenna offset from the robot geometric center has not been compensated, but even so it is evident that the EKF improves the position estimation accuracy significantly. Similar results though not as distinct were obtained from the other tracks. To test the reliability of the EKF several experiments were carried out using the same data but with GPS fix reset for periods of 5 to 20 seconds. In all tests the EKF managed to produce sensible output relying on odometry data until the next GPS fix corrected the absolute position.

### *3.3 Conclusion*

This work has evaluated the u-blox NEO-6P GPS performance in precision agriculture applications. In standalone static tests 95% of the position errors were within 1.98 m. In RTK static tests 95% of the position errors were within 0.013 m. In all standalone field tests more than 95% of the position errors were estimated to be within 2.6 m and in all RTK field tests more than 95% of the position errors were estimated to be within 0.2 m. It is concluded that the NEO-6P can be applied to selected row crop and orchard applications if augmented by local sensors and mapping techniques. The NEO-6P (LEA-6T) in RTK setup applies to general applications where 0.2 m position errors are acceptable. Prolonged tests and antenna vibration tests were performed in addition to the described tests. They gave no reason to review the above conclusion. An EKF was implemented to improve the robot state estimation. Work ahead is to add local sensors to enable robust navigation in orchards.

### **Acknowledgements**

*The authors wish to thank More Electronics, Thorbjørn Jørgensen, Anders G. Pedersen, Hjalte Nygaard and Carsten Albertsen for supporting this work.*

### **References**

- Grisso, R., Alley, M. and Heatwole, C. *Precision Farming Tools: Global Positioning System (GPS)* Virginia Cooperative Extension Publication 442-503. 2009.
- Takasu, T. and Yasuda, A., *Development of the low-cost RTK-GPS receiver with an open source program package RTKLIB*, International Symposium on GPS/GNSS, International Convention Center Jeju, Korea, November 4-6, 2009
- Larsen, T. *Optimal fusion of sensors*. PhD Thesis, The Technical University of Denmark. 1998.



## Reliable low cost sensors and systems for the navigation of autonomous robots in pot crop nurseries

Lorenzo Comba<sup>1</sup>, Sergio Finéz Martínez<sup>2</sup>, Paolo Gay<sup>1</sup>,  
Davide Ricauda Aimonino<sup>1</sup>

<sup>1</sup> *Università degli Studi di Torino, Dipartimento di Economia e Ingegneria Agraria  
Forestale e Ambientale, via Leonardo da Vinci 44 10095 Grugliasco (TO) – Italy (e-  
mail: paolo.gay@unito.it)*

<sup>2</sup> *Treelogic, Parque Tecnológico de Asturias, Llanera · Asturias – Spain (e-mail:  
sergio.finez@treelogic.com)*

**Keywords:** autonomous robots, multipurpose machines, pot-  
plants nurseries

---

### Abstract:

First results about the development of a reliable low cost navigation control system for an autonomous robotic platform are presented in this paper. The robot and its navigation system were conceived to operate in pot-plant nurseries, where simpler and more robust solutions can be adopted respect to open field. In pot-plant nurseries crops layout is usually very regular with pots arranged in plots on compact soil. Hence the navigation control can be carried out tracking a fixed ground reference, such as a ribbon, lied in the middle of the inter-rows. Different kinds of sensors were tested (optical infrared, capacitive and inductive). The best performances were achieved employing proportional inductive sensors coupled with a ribbon composed by metallic materials. The same solution was adopted to identify headlands and to maneuver in automatic way the robotic platform at the end of each plot.

---

### 1. Introduction

The introduction and diffusion of robotics for crops management is seen as a needful means to improve the modern agriculture, in terms of cost reduction and increase in productivity (Bakker et al., 2010). Robotic systems would also



lead significant improvements about environmental pollution reduction and workers safety. Agricultural environment is rather hostile and the introduction of robotic systems is very difficult, in particular regarding the autonomous navigation. A number of autonomous robots prototypes have been developed in this last decade as result of scientific research (see e.g. Åstrand and Baerveldt, 2002; Bakker et al., 2010; Slaghter et al., 2008; Sørensen et al., 2007). Most of them have been conceived to operate in open field, where the lack of fixed references and the great variability of environmental conditions strong affect the performances of the autonomous guidance controls. An integration of ground-base (odometers, computer vision, ultra sounds sensors, laser) and GPS systems is often adopted to recognize crop rows and identify headlands (Bakker et al., 2010). However, in most cases, the reliability and the overall performances of these navigation systems are not still adequate to the application in a real production context.

Pot plants nurseries, on the contrary, are more suitable to the introduction of autonomous robots than open field. Crops are usually organized with very regular layouts and fixed reference systems could be taken in account in this case; therefore well-established technologies could be adopted concerning the robots autonomous guidance.

A preliminary study of a reliable and low cost guidance system for an autonomous four steering and drive wheel robotic platform is presented in this paper. The robot, described in Comba et al. (2012) together its kinematic study, has been properly designed to operate in pot-plant nurseries as an autonomous multipurpose machine by changing different implements.

## **2. Robotic platform**

In pot-plant nurseries, pots are usually arranged in plots either inside glasshouses and walk-in-tunnels or outdoor, on concrete floors or compact soil covered with a plastic film. Plots, usually less then 1.6 m wide, are alternated with 0.2-0.4 m wide interrows. This kind of layout has guided the overall design of the robotic platform, which consists in a four steering and drive

wheels vehicle able to navigate along a single plot. Each wheel together its electrical propulsion and steering system is assembled in a wheel module, which is connected to the platform chassis by a pivot system coupled with a shock absorber (Fig. 1). Rotating simultaneously the four wheel modules, driven by as many electric linear actuators, the platform wheels-track can be adjusted in a range of 1000-1600 mm. This solution gives to the robot a high flexibility and adaptability to different contexts and crops layouts. Platform chassis host a diesel engine generator coupled with a set of batteries, the fuel tank as well as control and power electronic devices. A mechanical interface will be fixed on the chassis in order to connect to the platform different kinds of tools. In particular the robot was thought to perform precise spray applications and fertigation without human operation, as well as a number of operations on single pots (e.g. pots handling, trimming, fertilization with granular products).

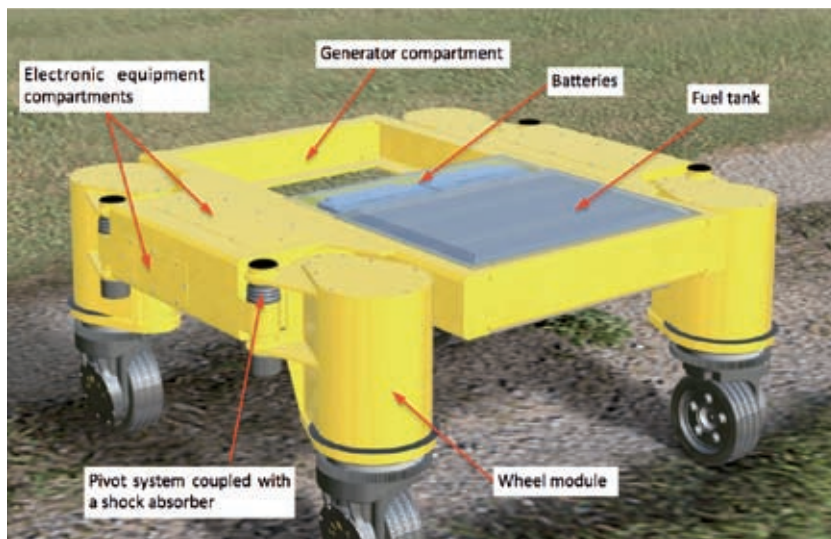

Fig. 1 – 3D rendering of the robotic platform basic structure

Robot control system is based on “a two layers” architecture. The basic layer consists in four “intelligent” drivers, which control the steering angle and the velocity of each wheel



according to the data provided by a central control unit. This one is the top layer, which collects and elaborates information from navigation sensors, tools and safety devices. All control devices and power driver exchange data by a CAN bus with an appropriate protocol.

### **3. Platform navigation control**

The navigation scenario in a pot-plant nursery, as already mentioned, is rather structured. During operations on crops, the robotic platform has to follow the inter-rows among plots, whereas, when it achieve the headland, it has to change plot or to comeback. Navigation control system was designed with the aim to reduce costs as much as possible, taking in account, at the same time, that the platform has to operate also in greenhouses, where the employment of GPS systems is usually critical.

These considerations suggested the employment of ground based sensors beside the on board odometers, in particular a ribbon lied on the middle of each inter-row as fixed ground reference. In this way the navigation control system corrects the steering angle of the wheels, tracking the ribbon with an adequate set of sensors. The same solution can be adopted to identify the headlands and to manoeuvre the platform from a plot to the next one. Turns and plot change can be performed fixing a further ribbon, perpendicularly to the inter-rows, near the headlands.

A first set of trials was carried out to identify the most adequate sensors; in particular optical infrared devices, capacitive and inductive wide range (150 mm) proximity sensors were tested. Optical infrared sensors were rejected just after few tests since their performances were strongly affected by lighting conditions as well as by the presence of dirt on ribbon surface. Capacitive sensors were tested with plastic strips (50 mm wide and 2 mm thick), but they had to be placed very close to the soil surface (less than 30 mm) to obtain adequate performances, moreover soil irregularities strongly affected the accuracy. The best solution was found employing inductive sensors, even if a tape

composed by metallic material must be used in this case. Platform steering angle can be calculated measuring the deviation of front and rear wheel modules from the centre of the tape. Since proportional inductive sensors give an output voltage proportional to the distance from a metallic body and/or to the quantity of metal within the sensor field of view, a couple of them has been adopted to calculate the deviation from tape centre, according to the schematic diagram of fig. 2. This solution gives also a good control robustness respect to soil irregularities, as vertical displacements are common mode signals rejected to the measurement system.

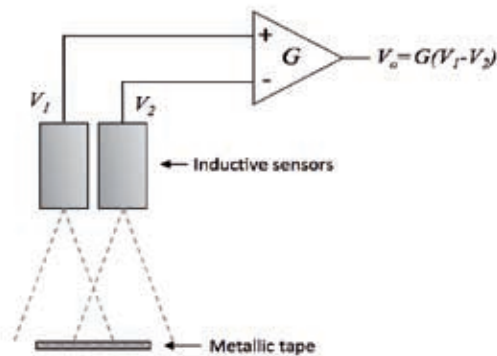

Fig. 2 – Schematic diagram of the tape tracking system based on a couple of proportional inductive sensors.

A couple of sensors will be installed in each wheel module. Two of them, one on the front and one on the rear wheel modules, will be use as tape tracking system for platform navigation along plots inter-rows, whereas the other two couples will be need to turn the robot at headlands autonomously.

#### 4. Conclusions

The employment of inductive sensors coupled with a metallic tape is a viable solution to develop a simple, reliable and low cost navigation system for an autonomous robotic platform conceived to operate in pot-plants nurseries.





Inductive sensors are standard and low cost devices already employed in different agricultural equipment for many years, as their accuracy is not affected by the presence of dirty, such as soil and crop residues. The fixed ground reference made by the tape gives a great reliability and robustness to the control system. Either fixed infrastructures or other kind of sensors are not required for robot navigation during crops operations. Metallic tape is a low cost product respect to other solutions, moreover growers can autonomously manage its application, defining a platform navigation pattern adequate to farm plots layout and farm scheduling.

### **Acknowledgements**

*This research is partially founded by “ROBOT” Manunet 2010 EU Project and PRIN2009 (prot. 2009FXN7HW\_002). Authors would like to thanks SINAU Macchine s.r.l. and REDA Elettronica for their factual collaboration.*

### **References**

- Åstrand B, Baerveldt A J 2002. *An Agricultural Mobile Robot with vision-based perception for mechanical weed control*. Autonomous Robots, 13, 21-35
- Bakker, T., van Asselt, K., Bontsema, J., Muller, J., van Straten. G. (2010). *Systematic design of an autonomous platform for robotic weeding*. Journal of Terramechanics, 47, 63-73.
- Comba L, Gay P, Ricauda Aimonino D (2012). *Robotic solutions for pot-plant nurseries*, Proceedings International Conference of Agricultural Engineering – AgEng 2012, 8-12 July 2012, Valencia, Spain.
- Slaughter D, Giles D, Downey D. (2008). *Autonomous robotic weed control systems: A review*. Computers and electronics in agriculture, 61, 63-78.
- Sørensen C, Nørremark M, Jørgensen R, Jensen K, Maagaard J, Jensen L A 2007. *Hortibot: Feasibility study of a plant nursing robot performing weeding operations - part IV*. ASABE Annual International Meeting, Minneapolis, Minnesota 17 - 20 June 2007.



**First RHEA International Conference on  
Robotics and associated High-technologies  
and Equipment for Agriculture**  
Hosted by the University of Pisa  
Pisa, Italy, September 19-20-21, 2012



**TOPIC n° 2.1**

**Vibration effects of bumper suspension system on pipeline  
sensor-based platform for soil water monitoring**

**Ioannis Gravalos<sup>1</sup>, Spyros Loutridis<sup>2</sup>, Dimitrios Moshou<sup>3</sup>,  
Theodoros Gialamas<sup>1</sup>, Dimitrios Kateris<sup>3</sup>, Zisis Tsiropoulos<sup>1</sup>,  
Panagiotis Xyradakis<sup>1</sup>**

*<sup>1</sup>Department of Biosystems Engineering, School of Agricultural Technology,  
Technological Educational Institute of Larissa, 41110 Larissa, Greece  
(gravalos@teilar.gr)*

*<sup>3</sup>Department of Electrical Engineering, School of Technological Applications,  
Technological Educational Institute of Larissa, 41110 Larissa, Greece.  
(loutridi@teilar.gr)*

*<sup>2</sup>Department of Hydraulics, Soil Science and Agricultural Engineering, School of  
Agriculture, Aristotle University, 54124 Thessaloniki, Greece  
(dmoshou@agro.auth.gr)*

**Keywords:** mobile platform, bumper suspension system, sensor  
-based platform

---

**Abstract:** This work examines the dynamic vibrational behavior of a bumper suspension system which is part of a sensor-based platform. The sensor-based platform travels through an underground pipeline system and monitors the soil water content in real time. The mechanical vibrations were measured with a triaxial piezoelectric accelerometer, and data acquisition system from **Brüel & Kjaer**. Based on the results obtained from the analysis of results, one may conclude that the modes in the y and z axes are interlinked. It is evident that the mode expected to cause most problems is that centered at 140 Hz. The r.m.s vibration value at high speed operation is almost double to that produced when the sensor operates at low speed.



## 1. Introduction

Currently, mobile robotic systems are used for automated inspection of the inner surface of piping systems using advanced techniques such as visual inspection, magnetic leakage detection, etc. (Qi et al., 2009). The pipeline robotic systems can be classified into the following categories, based on their driving mechanism: wheel type robot, caterpillar type robot, walking type robot, pig type robot, wall-press type robot, screw type robot, and inchworm type robot (Choi and Roh, 2007).

Wall-press type is one of the most popular in-pipe robotic systems. The advantage of wall-press type robot is the realization of adaptive (flexible) mechanism for pressing the wall. It solves several technical problems associated with the change in pipe diameters, presence of vertical pipes, and various elbows. Zhang and Yan (2007) proposed an in-pipe robot with active pipe-diameter adaptability and automatic tractive force adjusting for gas pipelines with different diameter. It consisted of three sets of parallelogram wheeled legs. Each leg had a front and rear driving wheel. The adaptive mechanism was driven by a step motor. This motor drives rotation of a ballscrew that can push the sets of parallelograms legs with driving wheels to contact surface wall of pipeline. Also, Choi and Ryew (2002) proposed an alternative type of wheeled leg mechanism. The proposed mechanism had three wheeled legs spaced  $120^\circ$  around the body of the robot. The folding and unfolding of the leg is succeeded on a pantograph mechanism with sliding base. The wall-press type robots interacted with the pipe wall with pressing forces in order to ensure adequate and stable traction. Due to this interaction mechanical vibrations were produced. The analysis of the vibrations can be subsequently used for the optimization of the robot operating parameters. In addition, the characteristics of vibrations should be used as a criterion of efficient operation of the wall-pressing mechanism of robots.

Gravalos et al. (2010) presented a sensor-based platform that travels through an underground pipeline system and monitors the soil water content in real time. This sensor-based platform

can be classified as a wall-press vehicle. It consists of a modified commercial soil water sensor Diviner 2000, which is placed on two circular articulated wheeled bases, each of them driven by a small wheeled electric motor. The driving wheels are supported via bumper suspensions. This suspension system allows motion only in vertical direction and relies on flexible members (compression springs) to hold the bumper loosely in place. The deflection of the bumper suspensions allows foldable characteristics for the driving wheels, which in turn are in contact with pipeline walls. The aim of this paper is to study the vibrational behavior of the bumper suspension system which is a part of a sensor-based platform used for soil water monitoring.

## 2. Materials and methods

Experiments were carried out in laboratory conditions, on an artificial soil tank 1.44 m long by 1.10 m wide, and with a depth of 0.25 m (Fig. 1). Three PVC pipeline was placed horizontally along soil tank at depths of 0.2 m under the soil surface. Apparatuses used in the study were the sensor-based platform and a vibration analyser. The mechanical vibrations of sensor-based platform were measured by a compact triaxial piezoelectric accelerometer type 4524-B. The accelerometer was attached on the body of mobile platform via mounting clip (UA-1407). The voltage signals of the accelerometer were sampled with the data acquisition unit PULSE type 3560-C from Brüel & Kjaer. Vibration levels were measured under two different operating speeds.

## 3. Results and conclusions

A number of three runs were tried both for low and high speed operation. The sampling frequency was 65536 samples per second. Each record typically contained a little more than 500000 points resulting in time series with duration of approximately 8 seconds. First, the root mean square (r.m.s) acceleration was numerically calculated directly from the time series. Next, the power spectral density (PSD) was computed using the Welch's statistical method. A Blackman window was



used with 50% overlap between successive segments resulting in a true frequency resolution of 16 Hz.



Fig.1. The experimental setup

1. soil tank, 2. sensor-based platform, 3. triaxial accelerometer,
4. electric motor, 5. reducing gear, 6. photoelectric sensor,
7. data acquisition unit PULSE type 3560-C, 8. laptop computer

For low speed operation, the mean value of r.m.s acceleration on x-axis is  $2.75 \pm 0.31 \text{ m/s}^2$ , while on y and z axes we have  $4.81 \pm 0.5 \text{ m/s}^2$  and  $5.44 \pm 0.36 \text{ m/s}^2$  respectively. Vibration magnitude is always higher along the z-axis direction. The general form of the power spectral density is computed from the x-axis vibration time series, it is that of a low pass filter passing frequencies up to about 200 Hz. This is to be expected as the mechanism is forwarded using rubber wheels that filter out high frequency vibration. A number of peaks are evident at approximately 40, 400 and 4000 Hz. These peaks may be associated with structure's modes excited by the contact between the wheels and tube walls. In case of the power spectral density of the y-axis acceleration, a number of modes are apparent at 140 Hz, as well as, at 5 and 6 kHz. Finally in fig. 2, the spectrum of the vibration along the direction of the z axis is presented. The general shape is similar to those of x-axis and y-axis, only the magnitude is a little higher. Two vibration modes are apparent at 140 Hz and 5900 Hz.

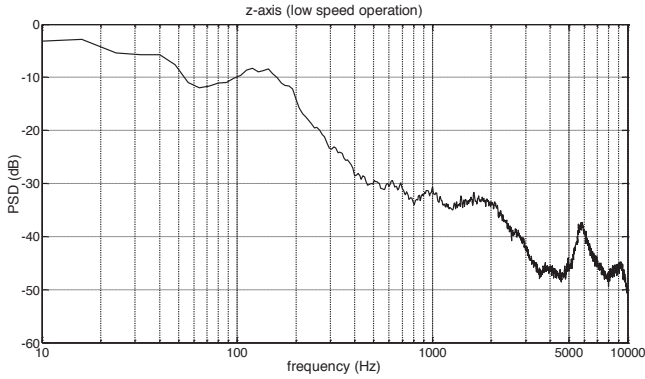

Fig.2. Power spectral density of vibration recorded on the direction of z-axis, low speed operation

For high speed operation, the mean value on x-axis is  $5.4 \pm 1.3$   $\text{m/s}^2$ , on y-axis  $9.05 \pm 2.5$  and on z-axis  $9.74 \pm 2.3$   $\text{m/s}^2$ . Vibration magnitude is almost doubled when compared to the case of low speed operation. The standard deviation is also significantly higher. As before, the highest values are observed along the z-axis direction. The PSD of the x-axis vibration when using high speed operation shows the same 40, 400 and 4000 Hz peaks as in the case of low speed operation. However, the 400 Hz peak is greatly suppressed. The spectral content of the y-axis vibration shows prominent peaks at 140, 1900, 5000 and 6100 Hz. Finally, the spectral content of the z-axis vibration contains two relatively undamped peaks at 140 and 5800 Hz, figure 3.

From the above one may conclude that the modes in the y and z axes are interlinked. The modes noticed along the direction of the x-axis are not linked to the modes in the other directions. Take out the magnitude of the vibration, the picture in the case of high speed operation is exactly the same as with low speed operation. This is to be expected because the modal behaviour of the structure depends only on the constructional details and is irrelevant to speed and type of excitation provided that the last one is broadband. It is well known, that the vibration amplitude is highest at resonance frequencies. A capacitive probe is quite insensitive to vibration effects. Nevertheless, when designing equipment it is always a good practice to take care of undamped



modes in order to increase both the measurement accuracy, as well as the reliability of the device. From figures 2 and 3, it is evident that the mode to cause most problems is that centered at 140 Hz. Higher modes may have much lower damping, but their excitation level is more than 20 dB lower and therefore are not expected to cause much trouble.

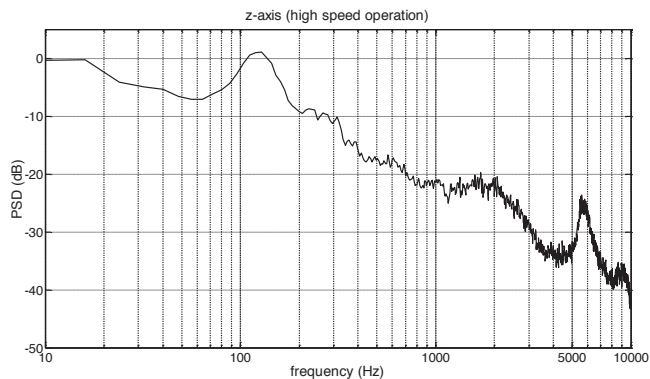

Fig.3. Power spectral density of vibration recorded on the direction of z-axis, high speed operation.

## References

- Choi, H.R., S.M. Ryew (2002). Robotic system with active steering capability for internal inspection of urban gas pipelines. *Mechatronics*, 12, 713-736.
- Choi, H.R., S.G. Roh (2007). *In-pipe robot with active steering capability for moving inside of pipelines*. Bioinspiration and Robotics: Walking and Climbing Robots, Book edited by Maki K. Habib. In-Tech, Vienna, Austria.
- Gravalos, I., S. Loutridis, D. Moschou, Th. Gialamas, D. Kateris, Z. Tsiropoulos, P. Xyradakis, M. Savoulidis, and Z. Koutsofotis (2010). *An underground experimental platform for soil moisture monitoring*. In: Proceedings of International Conference on Agricultural Engineering (AgEng 2010), 6-8<sup>th</sup> September, Clermont-Ferrand, France.
- Qi, H., X. Zhang, H. Chen and J. Ye (2009). Tracing and localization system for pipeline robot. *Mechatronics*, 19, 76-84.
- Zhang, Y., G. Yan (2007). In-pipe inspection robot with active pipe-diameter adaptability and automatic tractive force adjusting. *Mechanism and Machine Theory*, 42, 1618-1631.



**Session 4:**  
New trends in mobile robotics  
in agriculture





**First RHEA International Conference on  
Robotics and associated High-technologies  
and Equipment for Agriculture**  
Hosted by the University of Pisa  
Pisa, Italy, September 19-20-21, 2012



**TOPIC n° 2.1- Design and control of autonomous agricultural vehicles  
and systems**

**Hardware architecture design for navigation and precision  
control in autonomous agricultural vehicles**

**Luis Emmi and Pablo Gonzalez-de-Santos**

*Centre for Automation and Robotics (UPM-CSIC); 28500 Arganda del Rey; Madrid;  
Spain (e-mail: [luis.emmi@car.upm-csic.es](mailto:luis.emmi@car.upm-csic.es))*

**Keywords** Hardware architecture, Autonomous robots,  
Agricultural vehicles.

---

## **Abstract**

This article presents a general scheme of a centralized hardware architecture developed to be implemented on an autonomous agricultural vehicle. It has been devised to achieve precision agriculture tasks.

---

## **1. Introduction**

A large number of specialized sensors and actuation systems that improve efficiency and provide a powerful assistance to perform precision farming tasks have been developed in the last decades (i.e. machine vision, RTK GPS, laser-based sensors, inertial sensors). Most of these systems have been designed with the aim to build up semi-autonomous or fully autonomous agricultural vehicles (Åstrand and Baerveldt, 2002; Bakker et al., 2011; Li et al., 2009; Perez-Ruiz et al., 2012; Slaughter et al., 2008; Tian, 2002).

In a robotic agricultural application, considerable information has to be processed and a wide number of actuation signals has to be controlled. In order to achieve a robust, flexible, and reliable autonomous mobile robot for agricultural tasks, we have devised a centralized hardware architecture.

## **2. Approach**

The hardware architecture presented on this article has emerged based on the current requirements within the new developments



in autonomous vehicles for precision agriculture. This architecture is intended to be capable of integrating different sensory and actuation systems, developed by diverse research groups as well as commercial equipment of different nature. Among them, we can point out:

- Perception systems (mainly machine vision)
- LIDAR (Laser Imaging Detection and Ranging)
- Range sensors (Ultrasonic sensors, infrared sensors, etc.)
- Communication protocols
- Global Positioning System
- Inertial measurement units
- Vehicle controllers
- Implements (Herbicide boom controllers)
- Hydraulic and electric actuators

A hardware architecture needs to be flexible to merge together all these sensors, devices and systems, and also integrate several standard communication protocols, which are being common and common in high-tech agricultural applications.

### **3. Architecture for agricultural vehicles and tools**

We propose an architecture for agricultural machinery that relies on:

- A hybrid computing system consisting of a central powerful computer with fast network communication features to connect peripherals of different nature
- The central computer should exhibit truly real-time, multitasking features
- The central computer should have a large family of real plug-and-play hardware modules
- The central computer should provide capabilities to facilitate running software developed for different platforms and in different programming languages
- The central computer should be ruggedized to work in harsh conditions

All these requirements are fulfilled by the new family of National Instruments Corp. (NI) CompactRIO-9082 (cRIO-9082) computer, which offers a powerful stand-alone and

networked execution for deterministic Real-Time applications. This hardware platform contains a reconfigurable field-programmable gate array (FPGA) for custom timing, triggering, and processing, and also, a wide array modular I/O for any application requirement. The cRIO-9082 features:

- High-performance multicore system for intense embedded monitoring and control applications
- 1.33 GHz dual-core Intel Core i7 processor, 32 GB nonvolatile storage, 2 GB DDR3 800 MHz RAM
- LabVIEW Real-Time for determinism and continuous operation reliability
- 1 MXI-Express, 4 USB Hi-Speed, 2 Gigabit Ethernet, and 2 serial ports for connectivity, expansion
- 8-slot Spartan-6 LX150 FPGA chassis for custom I/O timing, control, and processing
- 0 to 55 °C operating temperature range

#### **4. A case study of the proposed architecture: The RHEA computing system**

The RHEA system consists of a fleet of heterogeneous (ground and aerial) robots for weed and pest management (RHEA, 2012). The ground mobile units are in charge of carrying perception systems for weed detection and actuation systems for weed removal as well as communication facilities to receive commands and report information to the base station located remotely. Our hardware architecture is devised for controlling these ground mobile units that contains the following subsystems:

- A weed detection systems to detect weed patches
- A crop row detection systems to help steering the vehicle
- Laser range finder to detect obstacles in the vehicle's path
- Ultrasonic sensors to detect tree canopy in woody perennial applications
- Communication equipment to link mobile units, base station and user portable devices
- GPS device to locate the vehicle



- Inertial measurement units (IMU) for accurate vehicle positioning
- A vehicle controller
- A herbicide boom controller
- Hydraulic and electric actuators for weed and pest tools
- Programmable Logic Controllers (PLC) for automating the electromechanical devices in the agricultural tools

All these subsystems are based on computers running different operating systems (Windows, Linux, QNX, etc.) and software modules developed in different languages (C++, .NET, etc). The first solution was to connect all subsystems through an Ethernet network and using a computer as a central controller. This starting solution is depicted in Fig. 1. The main controller is connected to the peripherals through either a serial line or the Ethernet network (802.3 Local Area Network) via an Ethernet switch, which requires a Network Manager running on a computer connected to the Ethernet Switch, normally the main controller.

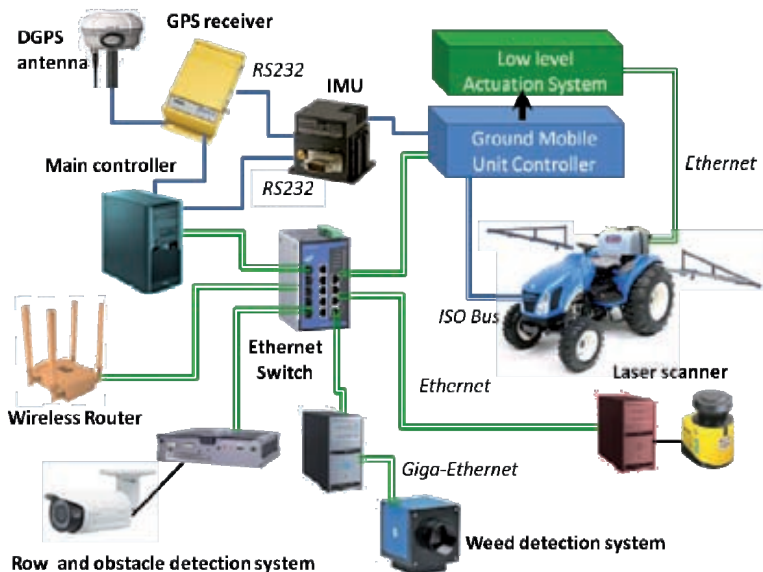

Fig. 1. General scheme of hardware architecture for an autonomous mobile robot for precision agriculture

The first step towards centralization consisted in integrating the Weed Detection System (WDS) into the cRIO. The initial clue was given by the fact that the vision camera is Giga-Ethernet compliant and the cRIO has two Gigabit Ethernet ports. That makes possible to connect directly the camera to the cRIO, eliminating the vision computer.

A second attempt to go on further in the centralization of the RHEA system is to unify the two vision systems Weed Detection System (WDS) and Row and Obstacle Detection System (RODS). Both systems use similar image-capture mechanisms and image-processing algorithms that can be integrated in the same computer saving hardware resources. The main problem with this configuration could be the lack of real parallelism in the execution of the algorithms, which increases the computing time. Nevertheless, this is compensated by the elimination of the delay in the information flow from the RODS to the Main Controller through the Ethernet.

These are two examples of possible system centralization of complex subsystems; however, other subsystems can be centralized in a simpler way. For instance:

- Ethernet: Available NI WLAN modules and Ethernet switch
- Laser: connected through Ethernet or specific modules
- Industrial communication buses: CAN bus and ISO bus can be integrated through NI CAN interfaces
- Inertial Measurement Units: connected through NI serial modules
- General I/O modules: NI analog and digital I/O modules

Figure 2 shows the final system fully integrated.

## **5. Results and conclusions**

The hardware architecture presented in this article is a simple, robust and reliable system in charge of both the navigation controller of an autonomous mobile robot for agricultural tasks and the control of the agricultural machinery elements. The general scheme presented in this article is expected to be





promising in order to be adopted and implemented by farmers that want to automate daily tasks in crop fields.

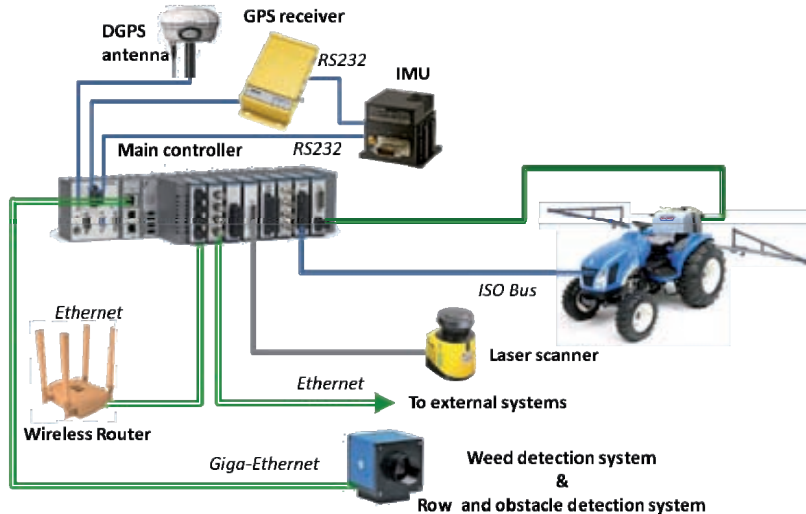

Fig. 2. Prospective hardware configuration for RHEA

## Acknowledgements

*The research leading to these results has received funding from the European Union's Seventh Framework Programme [FP7/2007-2013] under Grant Agreement n° 245986.*

## References

- Åstrand, B. and Baerveldt, A. J. (2002). *An Agricultural Mobile Robot with Vision-Based Perception for Mechanical Weed Control*. *Autonomous Robots*, 13(1), pp. 21-35.
- Bakker, T., van Asselt, K., Bontsema, J., Müller, J. and van Straten, G. (2011). *Autonomous navigation using a robot platform in a sugar beet field*. *Biosystems Engineering*, 109(4), pp. 357-368.
- Li, M., Imou, K., Wakabayashi, K. and Yokoyama, S. (2009). *Review of research on agricultural vehicle autonomous guidance*. *International Journal of Agricultural and Biological Engineering*, 2(3), pp. 1-16.
- Perez-Ruiz, M., Slaughter, D. C., Gliever, C. and Upadhyaya, S. K. (2012). *Tractor-based Real-time Kinematic-Global Positioning System (RTK-GPS) guidance system for geospatial mapping of row crop transplant*. *Biosystems Engineering*, 111(1), pp. 64-71.
- RHEA (2012), Robot fleets for highly effective agriculture and forestry management. Available at: <http://www.rhea-project.eu/>
- Slaughter, D. C., Giles, D. K. and Downey, D. (2008). *Autonomous robotic weed control systems: A review*. *Computers and Electronics in Agriculture*, 61(1), pp. 63-78.
- Tian, L. (2002). *Development of a sensor-based precision herbicide application system*. *Computers and Electronics in Agriculture*, 36(2-3), pp. 133-149.



TOPIC n° 2.1

## Monitoring of Sugar Cane Plantations by a Micro- Unmanned Aerial Vehicle

Tania L. Laura<sup>1</sup>, Armando S. Sanca<sup>2</sup>, João Paulo F. Guimarães<sup>3</sup>, Michel S. De Deus<sup>1</sup>, Alessandro N. Schildt<sup>1</sup>, Pablo J. Alsina<sup>1</sup>, Adelardo A. D. de Medeiros<sup>1</sup>

<sup>1</sup> *Universidade Federal do Rio Grande do Norte, Departamento de Computação e Automação, Natal, Brazil.*

<sup>2</sup> *Universidade Estadual de Feira de Santana, Centro de Tecnologia, Bahia, Brazil.*

<sup>3</sup> *Instituto Federal do Rio Grande do Norte, Apodi, , Brazil.*

**Keywords:** Aerial monitoring, Sugar cane, Visual servoing, UAV-VTOL.

---

**Abstract:** This work describes the development of system for monitoring of plantations of sugar cane through a small UAV, specifically a multi-rotor helicopter properly instrumented to capture and send images to a base station for further analysis. The visual information of the whole ecosystem will allow judicious comparisons about processes such as photosynthetic activity, the occurrence of water deficits, nutritional stress and pest attacks. Preliminary results of the proposed system are shown.

---

### 1. Introduction

The Brazilian agriculture plays an important role in the development of the country, generating employment, incomes and international trade. In this context, the cane sugar is inserted as a main raw material of the production of sugar, alcohol, and other byproducts. The cultivation of sugar cane was the first agricultural crop introduced in the country. It has been cultivated for four centuries on the Brazilian Northeast coast. More recently, with the increase in the demand for ethanol, this culture has spread out to almost all Brazilian states, establishing itself in many different soil types. Today, the domestic



production of sugar cane is around 290 million tonne/year and sets the country as a world leader in this economic sector. The sugar cane is directly linked to the own history and development of Brazil (Embrapa, 2012).

Even though the sugar cane is a rustic plant, due to its economic importance today in Brazil, heavy investments to its cultivation are being made, since the environmental characteristics and competitiveness require high productivity, reduction in costs and environmental impacts studies. Moreover, situations difficult to anticipate may arise during cultivation, for example; the appearance of pests, if appropriate actions are not taken, can lead to a drastic decrease on cane production, resulting in the reduction on the sugar and ethanol production. Therefore, in order to prevent pests, reduce pesticide applications, reduce the risk of contamination of those who apply and prepare the insecticides and decrease the contamination of the environment and consumers of final products, it is necessary to make rounds of monitoring of the plantations. (Germano L. D. Leite and Vinicius M. Cerequeira, 2010).

The objective of this work is to develop a system for aerial monitoring based on a small unmanned multi-rotor helicopter properly instrumented to capture and send images of plantations of sugar cane to a base station for further analysis. Image processing techniques will allow the extraction of relevant information about processes such as photosynthetic activity, the occurrence of water deficits, nutritional stress and pest attack.

## 2. Methodology

The task of aerial monitoring of a sugar cane plantation consists in moving the UAV (*Unmanned Aerial Vehicle*) between certain planned points to get image samples. These samples are very close pictures of the plants with low distortion and low noise, which will be sent via WiFi connection to a base station for later analysis by a specialist. Images with low noise and close to the sugar cane plantations can be captured when the helicopter hover near them.

## 2.1 Development and Operation of an UAV

The UAV developed in Robotic Laboratory (LAR) at DCA/UFRN<sup>1</sup>, consists of a hexarotor helicopter with three rigid axes that are equidistant to its centroid, as shown in Fig.1. Six rotors are arranged as three co-axial pairs without gears installed on each rotor axis. A co-axial rotor is defined as having an upper and a lower rotor that rotate in opposite directions to each other. This co-axial layout doubles the thrust without increasing the size of the whole structure, and naturally eliminates loss of efficiency due to yawing moments and torque compensation (Sanca et al., 2010a, (Sanca et al., 2010b; Laura et al., 2011). This system has better stability than traditional helicopters. The power obtained from the six actuators results in increased payload on each rotor axis.

The movements up/down, forward/backward, left/right and the yawing motions are achieved through a differential control strategy of the thrust generated by each co-axial pairs. This helicopter is instrumented with a Sonar, Altimeter, GPS and AHRS (Attitude Heading Reference System), which provides measurements of its position and attitude with respect to inertial frame and with an image acquisition module that acquires images of a sugar cane plantations.

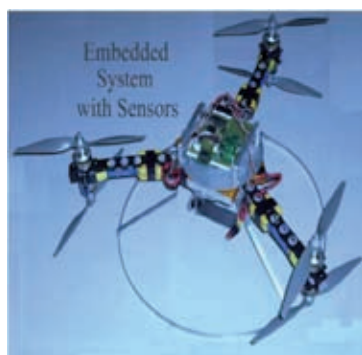

Fig.1. The Hexarotor helicopter developed in LAR/UFRN.

---

<sup>1</sup>Departament of Computing Engineering and Automation/Federal University of Rio Grande do Norte – Natal - Brazil.



## 2.2 Hardware architecture

The hardware architecture used is based on Master-Slave paradigm, which uses a USB bus as communication interface. The bus master is an embedded computer running Ubuntu Linux O.S., connected to some microcontrollers slaves through USB. This architecture was designed in a modular way, where other microcontrollers can be inserted, adding new functionalities to the system. The hardware architecture is shown in Fig.2.

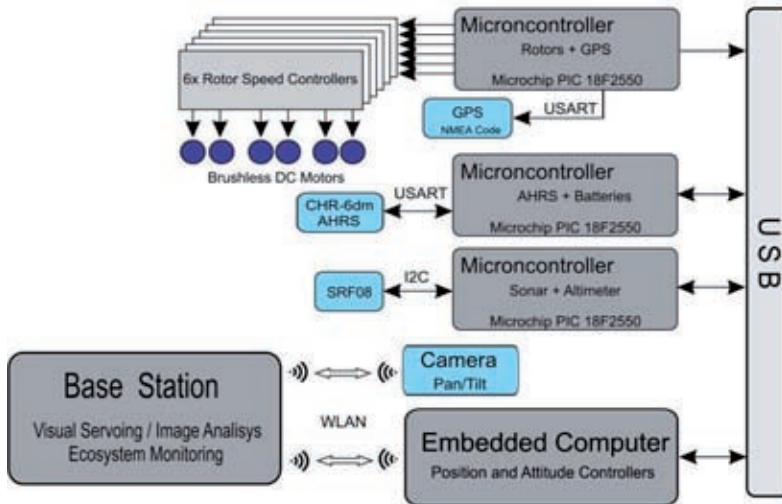

Fig.2. The hardware architecture

## 2.3 Base Station

The base station is the interface used by the operator on the ground. It was implemented on a mobile computer (Laptop) and provides the visual information concerning the UAV telemetry and images captured by the onboard camera during the hovered flight. It is possible send high level commands such as “LAND”, “TAKE-Off” and GPS reference coordinates.

The software was developed in modules in order to allow communication between the robot and the base station by three different links.

- ✓ Protocol Wi-Fi 802.11g,

- ✓ Circuit Switching: Uses GSM a modem in the embedded computer and another in the base station computer,
- ✓ Radio frequency: Long range Xbee Modules.

This base station was essential for monitoring tasks and real time flight control (Laura et al, 2011).

### 3. Results and conclusions

Fig.3, shows the attitude and altitude backstepping control based on Sanca et al., 2010b and Sanca et al., 2011. The tracking error results (roll-pitch-yaw attitude angles  $\phi$ ,  $\theta$ ,  $\psi$  and altitude  $z$ ) show the asymptotic stability of the backstepping approach applied to the hexarotor. It can be seen the good tracking performance of the developed controller.

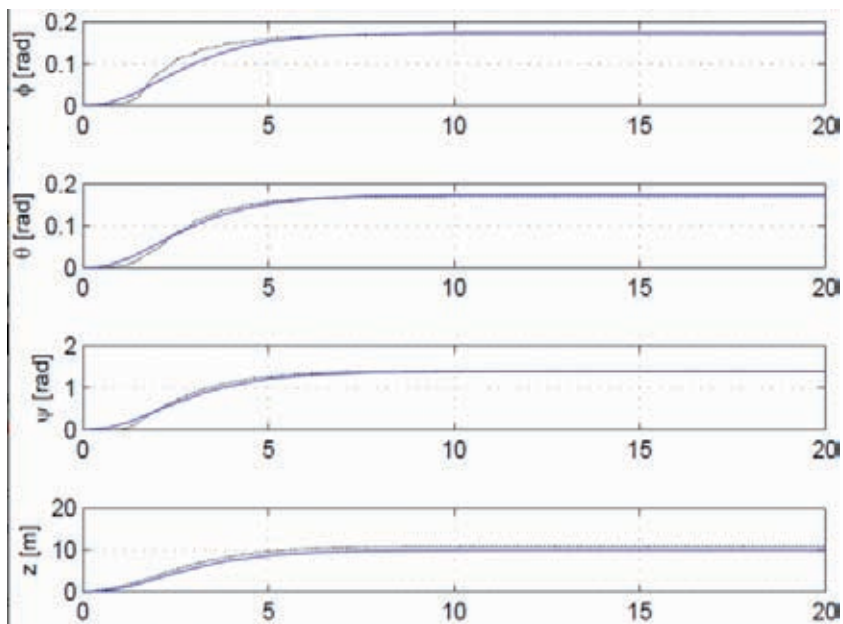

Fig. 3. Attitude and altitude of the helicopter.

Fig 4 shows the graphic interface on the base station utilized by the operator to control the UAV and monitor the sugar cane plantations during a planned monitoring mission.



The next step in the development of the proposed system is the implementation of specific image processing techniques for detecting pest from the captured aerial images. The use of the proposed unmanned helicopter for monitoring plantations will minimize the time in the detection of pests that attack sugar cane, thus contributing to the prevention of pest attacks.



Fig. 4. Graphic interface used in the base station for Monitoring sugar cane plantations.

## References

- <http://www.cana.cnpm.embrapa.br/index.html> (2012). *Impacto Ambiental da Cana-de-Açúcar*. Laura, T. L. ; Alsina, P. J. ; Medeiros, A. A. D. ; Guimarães, J. P. F. ; Sanca, A. S. 2011. *Posicionamento de um veículo aéreo não tripulado para detecção de corrosões em dutos*. Petro & Química, v. 338, p. 38-43.
- Sanca, A.S., Guimarães, J.P.F. and Alsina, P.J., 2011. "A real-time attitude estimation scheme for hexarotor micro aerial vehicle". In 21<sup>st</sup> International Congress of Mechanical Engineering. pp. 1-7 .
- Sanca, A.S., Alsina, P.J. and Cerqueira, J.J.F., 2010a. "Dynamic modeling with nonlinear inputs and backstepping control for a hexarotor micro-aerial vehicle". In 2010 Latin American Robotics Symposium and Intelligent Robotics Meeting. pp. 36-42.
- Sanca, A.S., Guimarães, J.P.F., Cerqueira, J.J.F. and Alsina, P.J., 2010b. "Hexarotor design project: Modeling and energy management for outdoor aerial robot". In VI National Congress of Mechanical Engineering, Campina Grande, PB, Brazil. pp. 1-9.
- Sanca, A.S., Alsina, P.J. and Cerqueira, J.J.F., 2008. "Dynamic modelling of a quadrotor aerial vehicle with nonlinear inputs". In IEEE/LARS Latin American Robotic Symposium. pp. 143-148.





**TOPIC n° 2.1**

**Non invasive moisture measurement in agricultural fields  
using a rolling spherical robot**

**Juan D. Hernández\*, David Sanz, Jorge Barrientos, João  
Valente, Jaime Del Cerro, Antonio Barrientos.**

*Center for Automation and Robotics - CAR UPM-CSIC C/ Jose Gutierrez Abascal, 2 -  
28006 Madrid, Spain ([juandhv@etsii.upm.es](mailto:juandhv@etsii.upm.es))*

**Keywords: crops, precision-agriculture, sphere, humidity.**

---

**Abstract:** Irrigation management in large crop fields is a very important practice. Since the farm management costs and the crop results are directly connected with the environmental moisture, water control optimization is a critical factor for agricultural practices, as well as for the planet sustainability. Usually, the crop humidity is measured through the water stress index (WSI), using imagery acquired from satellites or airplanes. Nevertheless, these tools have a significant cost, lack from availability, and dependability from the weather. Other alternative is to recover to ground tools, such as ground vehicles and even static base stations. However, they have an outstanding impact in the farming process, since they can damage the cultivation and require more human effort. As a possible solution to these issues, a rolling ground robot have been designed and developed, enabling non-invasive measurements within crop fields. This paper addresses the spherical robot system applied to intra-crop moisture measurements. Furthermore, some experiments were carried out in an early stage corn field in order to build a geo-referenced WSI map.

---

## **1. Introduction**



Water is the most important resource in any agricultural scenario. It defines the cost of the production, the quality of the crop and the performance of the field. In this sense, the irrigation management is one of the main tasks/goals to be taken into account in the Precision Agriculture (PA) concept.

Many techniques have been used to make effective this control. Nevertheless, all of them are based in the moisture measurement. Without considering non-real time methods, the sensor types could be divided according with their nature: on the one hand, it could be classified between static and mobile sensors. Despite of being more accurate, static sensors (like WSN) requires lot of devices in large fields, being most of the times too expensive. On the other hand, the acquisition systems could be also split according to their range and precision. On the bases of range (not only sensor range, but also coverage) and accuracy have an inverse relation, a deal is required. In this sense, this paper presents the work done in this direction, by the usage of a rolling robot with a spherical shape, named "ROSPHERE" (RObotic SPHERE), as an alternative mobile platform to perform monitoring tasks in crops, particularly to measure moisture, but not limited to that function.

The main purpose of using this alternative vehicle is to minimize crops alterations, and at the same time, being able to have a direct measurement from plants surroundings. By doing so, an action needed over a crop can be done directly to the specific affected area, these actions may include water irrigation, application of pesticides or fertilizers, etc. This precise action results in economical and environmental costs minimization, while maximizing revenues.

Unmanned Aerial Vehicles (UAV) are also used for similar purposes. The UAV mission is to image survey the crop fields. The images acquired are used to build a high resolution map, which can then be employed in weeding tasks. An important research effort is dedicated to compute optimal trajectories for mini UAVs, such as quad-rotors (Valente, Barrientos, del Cerro, & Sanz, 2011a), (Valente et al., 2011b). The aim of the proposed system is not to replace what aerial systems do, but instead to complement it. While the UAV surveys the overall field and

biophysical parameters can be obtained through image analysis. The ROSPHERE has the possibility to do *in situ* inspection and analysis. Thus, improving the reliability of the maps with further and more accurate data.

## **2. Problem statement and proposed solution**

The main objective in PA is to minimize environmental impact while maximizing the usage of non-renewable resources (e.g. water). A local measurement of control variables such as temperature, pesticide concentration, luminosity, humidity, etc. might indicate a necessary and controlled action over the crop.

Accordingly, the main objective is to be able to evaluate the real status of the crop, not only from a global point of view but locally. The solution (system) must be able to assess the crop state without affecting the involved plants. This discards an important part of existent mechanisms, mostly because of their size and weight.

Taking into account the requirements mentioned before, a robotic sphere is proposed as an alternative solution. Robotic spheres are systems in which movements are induced by instability. Besides, considering its regular shape, the robot may recover easily from collisions, regardless the direction of the impact, the robot tends to fall into a recoverable configuration. Finally, in spite of its size, a robotic sphere is relatively lighter compare to analogous robot of the same size. Even though there are several alternatives to conceive this concept (Armour & Vincent, 2006), a fixed axis ballast system has been selected as the mechanical alternative (Michaud & Caron, 2002), (Kayacan, Bayraktaroglu, & Saeys, 2011).

## **3. System description**

ROSPHERE is a spherical shape robot with the capacity to self-induce non-holonomic movements. To make that possible, the robot has an inner two-degree-of-freedom pendulum. The robot includes *a*) a spherical shaped body (30 cm of diameter), *b*) a



fixed main axis, *c*) a central unit or ICU (Internal Control Unit) and *d*) the ballast or hanging mass. The first DOF rotates the ICU (consequently the hanging mass) about the fixed axis, while the second has a mechanically limited range of rotation, and rotates about a perpendicular axis. Current version of the robot (see Figure 1) was designed to get the Centre of Mass as far as possible to the geometrical center in order to induced movements easily.

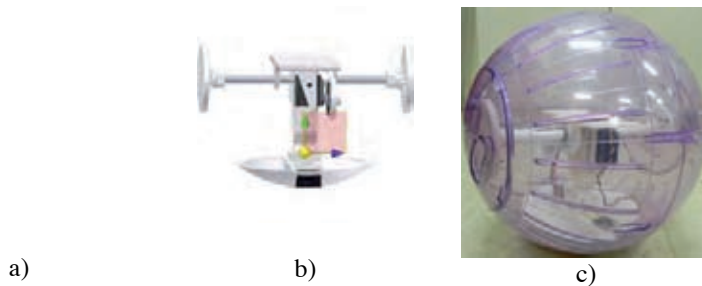

**Figure 1: ROSPHERE v0.2. a) Concept. b) CAD design of inner mechanical system. c) Real prototype**

### *3.1. Hardware architecture*

ROSPHERE is equipped with all necessary resources in order to behave as an autonomous vehicle. Besides, the system includes an embedded computing system composed by a Robovero and a Overo Fire embedded computer. ROSPHERE has WiFi, Bluetooth and Xbee as communication alternatives, furthermore it also includes sensors to measure inertial quantities (IMU), location (GPS), temperature, humidity, and luminosity.

### *3.2. Software architecture*

With respect to software, system architecture can be divided in two main parts. The first one corresponds to the high-level computation layer, which has to interpret primitive movement commands and generate the respective actuators commands, which could be provided by a human operator (in the teleoperation mode) or decided autonomously by the own navigation system (autonomous mode). On the other hand, there

is a low-level computation layer that is in charge to collect (read) information from sensors and to control actuators.

#### **4. Tests and results**

ROSPHERE v0.2 was tested in two different crops, winter cereal and corn (See Figure 2), and it was provided with environmental sensors of temperature and humidity. For this test, the robot was teleoperated to move inside the crop in order to get information about mentioned variables. Temperature and humidity variations were registered and can be visualized in Figure 3.



**Figure 2: ROSPHERE measuring enviromental variables. a) In winter cereals  
b) corn crops**

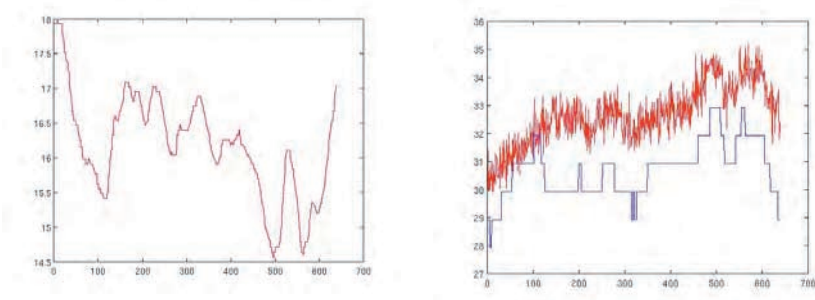

**Figure 3: Temperature and humidity measurements**



## 5. Conclusions

With these tests, it was validated ROSPHERE's capacity to move along the crop while taking environmental data. However, it was concluded that the robot should be used only in wide crop row spacing in order to guarantee the plant integrity. Furthermore, a possible enhancement is to locate the sensors outside of the sphere in each of the ends of the main axis. This will improve considerably data accuracy.

## Acknowledgements

*This work has been supported by the Robotics and Cybernetics Research Group at Technique University of Madrid (Spain), and funded under the project 'Robot Fleets for Highly Effective Agriculture and Forestry Management', (RHEA) sponsored by the European Commission's Seventh Framework Programme (NMP-CP-IP 245986-2 RHEA).*

## References

- Armour, R. H., & Vincent, J. F. V. (2006). Rolling in nature and robotics: A review. *Journal of Bionic Engineering*, 3(4), 195–208.
- Kayacan, E., Bayraktaroglu, Z., & Saeys, W. (2011). Modeling and control of a spherical rolling robot: a decoupled dynamics approach. *Robotica*, 1–10.
- Michaud, F., & Caron, S. (2002). Roball, the Rolling Robot. *Autonomous Robots*, 12(2), 211–222.
- Valente, J., Barrientos, A., del Cerro, J., & Sanz, D. (2011a). A waypoint-based mission planner for a farmland coverage with an aerial robot - a precision farming tool. Presented at the 8th European Conference on Precision Agriculture (ECPA'11).
- Valente, J., Barrientos, A., del Cerro, J., Rossi, C., Sanz, D., & Garzón, M. (2011b). Practical issues and improvements in farmland coverage with aerial vehicles, Research. Presented at the First Workshop on Research, Development and Education on Unmanned Aerial Systems (RED-UAS 2011).



**First RHEA International Conference on  
Robotics and associated High-technologies  
and Equipment for Agriculture**  
Hosted by the University of Pisa  
Pisa, Italy, September 19-20-21, 2012



TOPIC n° 2.1

## RISK ANALYSIS FOR UAV SAFE OPERATIONS: A RATIONALIZATION FOR AN AGRICULTURAL ENVIRONMENT

David Sanz\*, Joao Valente, Jaime Del Cerro, Miguel Angel de Frutos, Juan Jesus Roldan and Antonio Barrientos.

*Center for Automation and Robotics - CAR UPM-CSIC C/ Jose Gutierrez Abascal, 2 -  
28006 Madrid, Spain (d.sanz@etsii.upm.es)*

**Keywords:** mUAV safe operation, risk analysis,

---

**Abstract:** The road to the automation of the agricultural processes passes through the safe operation of the autonomous vehicles. This requirement is a fact in ground mobile units, but it still has not well defined for the aerial robots (UAVs) mainly because the normative and legislation are quite diffuse or even inexistent. Therefore, to define a common and global policy is the challenge to tackle. This characterization has to be addressed from the field experience. Accordingly, this paper presents the work done in this direction, based on the analysis of the most common sources of hazards when using UAV's for agricultural tasks. The work, based on the ISO 31000 normative, has been carried out by applying a three-step structure that integrates the identification, assessment and reduction procedures. The present paper exposes how this method has been applied to analyze previous accidents and malfunctions during UAV operations in order to obtain real failure causes. It has allowed highlighting common risks and hazardous sources and proposing specific guards and safety measures for the agricultural context.





## 1. Introduction

The use of new technologies and techniques in the agricultural environment has arisen in the last decades. This remarkable increment, named Precision Agriculture (PA), has allowed reducing the use of pesticides, maximizing the irrigation efficiency or having an actual knowledge of the crop status. A significant part of these advances lies in the aerial imagery. This possibility is provided by several means, from satellites to airplanes, each one with its own advantages and disadvantages. Nevertheless, for some years ago, both the agricultural and robotics societies have assisted to the mini Unmanned Aerial Vehicles (mUAVs) development. Due to their large availability, reduced price and great flexibility, they are considered to be the best alternative for this kind of applications.

However, in spite of all their large set of advantages, they present also inconveniences. The main one is derived from the relative youth of these devices, which makes to have not a solid legal framework neither a great robustness. It inevitably implies risks during operation, with a great potential damage capacity due to their air-vehicle condition. In this work, these risks have been analyzed, presenting an overview of the main hazards for UAV operations in agricultural tasks.

## 2. Risk analysis

### *2.1 Legal framework*

The applicant legislation is based on a generalist assessment of potential hazards, so –apart from being compulsory- supposes a first step in the risk analysis. Nevertheless, since the Unmanned Aircraft Vehicles are relatively new, this normative and legislation are still under current development (JAA/EUROCONTROL, 2004). Diverse organisms -both national and international; both official and non-official- are implied in this development. The US' FAA and the European EASA, together with EUROCAE, JARUS and some other organizations, reached a consensus in 2005 [6] to define formal policy for UAV certification and a clear regulation for the National Air Space (NAS) management. Nevertheless, this agreement only considers large and heavy drone, leaving the Light UAVs (UAVs under 150 Kg) regulation to the corresponding national Air Authorities.

Apparently, the most advanced frameworks for regulating the UAVs operation are present in UK, Australia, Austria and France (P. van Blyenburgh, 2008). Nevertheless, they have used different classifications for organizing the drone's regulation, making harder the standardization process. The common points in the on-going proposals have considered mUAV to those aerial vehicles lighter than 7/15Kg, 150m maximum height and flying under Visual Line of Sight (VLOS). On that basis, they have limited the maximum energy on impact, the maximum flight speed, distance to populated areas and altitude, as well as the airworthiness requirements.

## *2.2 UAV specific methodology*

After a careful study of both the specific and general regulations, it has been considered that current normative is not clear enough (K. Hayhurst et al, 2006). In spite of many groups and organisms are working on it, a common regulation does not seem to be available in a short/medium period, even less if expecting concrete recommendation for agricultural environments (R. Clothier et al, 2007; P. Hokstad et al, 2006).

In this sense, in (Sanz et al., 2012) is described a three-step architecture specific for this kind of missions. It is based on ISO 31000 normative and aims to enhance the evaluation overcoming the context-limitations and deficiencies observed. The first step corresponds to the Risk Identification (RI), including not only the limitations imposed (physical, temporal, behavioral and environmental restrictions), but also the potential hazardous situations and breakdown sources. In this regard, both external and internal sources have been considered, distinguishing the hazards according to their nature.

The following step is where all these identified risks are evaluated according to the application: Firstly, this risk assessment method enhances the factors considered in ISO 31000 (Seriousness of the damage and probability of occurrence). It is complemented by using parameters like the affiliation of the agents involved in the event, or by extending the severity-of-the-injures rate. Secondly, as far as this step allows weighting the importance of some parameters, it is possible to adjust the assessment for an agricultural environment. It allows the final step (Risk Reduction, RR) to decide where to



intensify the effort: design process, prevention/protection methods or safety procedures.

### 3. Agricultural environment: a case of use

This architecture is not only valid for analysing the potential hazards, but also for evaluating an accident. Figure 1 presents the partial layout of an imagery mission that resulted in disaster, where it is possible to distinguish a sudden fall.



a) Top view of the path

b) Isometric view of the path

Fig. 1. Real mission layout

Following the three-step methodology for analysing the risk, the first step was to analyse identify the potential hazards. On the one hand, those ones derived from the system restrictions: In relation with the physical limits, it was checked that the payload (camera, 126gr) was balanced and that not overcome the maximum Take-Off Weight (MTOW, 550g of payload). It was also checked that the wind speed (11 Km/h) was suitable and the battery charge.

Regarding to the temporal limits, it was assumed the use of the battery (6h) and the motors (around 10h the older one). The mission's duration (14min) was under the theoretical limit (20min) and the link quality was good. As well, in reference to the environmental limits, it was considered that the closer airport or military facility was dozens of kilometres away, and the nearest populated is at 2.5 Km far from the test area. Besides, the higher relative altitude of the mission was 55m, below the non-segregated air space level, and no body, apart from the pilots, was present in the test area. The GPS signal was excellent, as well as the climatological conditions.

Finally, in respect of the behavioural limits, the autonomous mode was set, supervised by an expert pilot.

On the other hand, also the hazards derived from breakouts were considered, focusing in the controllable stages (Preparation, start-up, maintenance and operation). Among them, Assemble, Adjustment, Interferences and Conservation processes were estimated as the most hazardous ones, so a special attention was paid on these processes. Nevertheless, as far as the accident happened, telemetry data have been used to focus on the analysis of possible breakdowns: Figure 2 presents the charts associated to the linear speed ( $V$ , green), the relative height ( $rH$ , red) and the acceleration ( $A$ , blue), all of them along the time and referred to the  $Z$  axis. It is possible to observe that during the mission,  $V$  and  $A$  are kept almost constant around 0, as could be expected since the  $rH$  is also stable. It could be also observed that from  $t=6'16''$  to  $6'19''$  there is a small descent, non-compensated by the quadrotor yet. This could be due to some changes in the orography, a maintained wind or a battery status warning. Nevertheless, the critical point is placed in  $t = 6'20''$ , where the drone suddenly changes not only in terms of  $V$  and  $A$ , but also its attitude and angular rates.

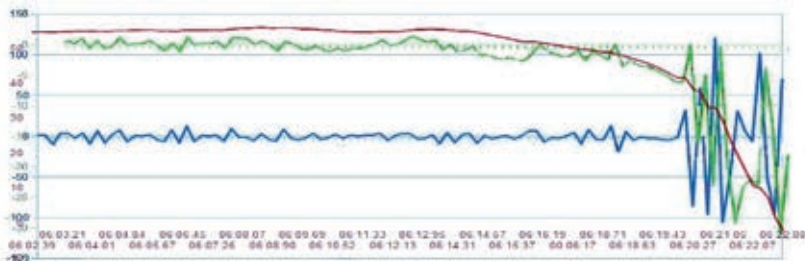

Fig. 2. Partial flight telemetry for breakdown analysis.

Since these changes do not compensate the drift, few problems could be considered: errors in the control/navigation system, failures in the link stream (both GPS and communications), mechanical breakdowns, battery dead or unmanageable weather conditions. The three last options are not probable, since the telemetry was received without problems, highlighting a good GPS signal; the battery warns when it is exhausted and enters in an emergency landing procedure; and the weather conditions were fine. Only control and mechanical troubles remain, and as far as their effects are quite similar – unbalance of the system's equilibrium – is really hard to distinguish between them. Even so, given that  $V$  and  $A$  seems to be saturated



trying to counteract the fall vector -changing to the contrary when the drone turns- could be supposed that the error has a physical nature. The driver/shifter, the propeller or the rotor could be the responsible of the accident.

Further analysis showed that, although broken due to the impact, the propeller was steadily fixed (and it is not probable to be broken during the flight). As well, the later test showed that the rotor worked properly. This leads to set that the driver –burned- caught fire during the flight.

#### 4. Conclusions

As could be expected, breakdowns and failures could be present despite of the precautions and methodologies applied. In this sense, only physical guards, such as a parachute or a safety ring, or redundancy systems (e.g. voltage regulators and limiters), could increase the safety figure, by warning in advance or by limiting the potential damage to be caused.

#### Acknowledgements

*This work has been supported by the Robotics and Cybernetics Research Group at Technique University of Madrid (Spain), and funded under the project 'Robot Fleets for Highly Effective Agriculture and Forestry Management', (RHEA) sponsored by the European Commission's Seventh Framework Programme (NMP-GP-IP 245986-2 RHEA).*

#### References

- JAA/EUROCONTROL, "Uav task-force final report. a concept for the european regulations for civil unmanned aerial vehicles (uavs)," JAA/EUROCONTROL, Tech. Rep., May 2004..
- P. van Blyenburgh, "Unmanned aircraft systems: The current situation," in EASA UAS Workshop, Feb. 2008.
- K. Hayhurst, J. Maddalon, P. Miner, M. DeWalt, and G. McCormick, "Unmanned aircraft hazards and their implications for regulation," in 25th Digital Avionics Systems Conference, 2006 IEEE/AIAA, Oct. 2006, pp. 1–12.
- R. Clothier, R. Walker, N. Fulton, and D. Campbell, "A casualty risk analysis for unmanned aerial system (uas) operations over inhabited areas," in AIAC12 – Twelfth Australian International Aerospace Congress, 2nd Australasian Unmanned Air Vehicles Conference, Melbourne, 2007.
- P. Hokstad and T. Steiro, "Overall strategy for risk evaluation and priority setting of risk regulations". Reliability Engineering ; System Safety, vol. 91, no. 1, pp. 100–111, 2006:
- D.Sanz, J.Valente, J.Colorado, J.D.Hernandez, J.del Cerro and A.Barrientos. "Safe operation of mini UAVs: A review of regulation and best practices". Accident Analysis & Prevention, 2012. (to be published).





## Topic 2.2

# Computer vision and image analysis in agricultural processes



**Session 1:**

Advanced procedures for image analysis  
of remotely sensed data  
in cropping systems





TOPIC n° 2.2

**A Weed/Crop Segmentation Method Based on Fuzzy  
Clustering for Remote Images**

**P. Javier Herrera<sup>1</sup>, Ana I. de Castro<sup>2</sup>, Francisca López-Granados<sup>2</sup>, Montserrat Jurado-Expósito<sup>2</sup>, Ángela Ribeiro<sup>1</sup>**

<sup>1</sup>*Center for Automation and Robotics, CSIC-UPM, 28500 Arganda del Rey, Madrid, Spain (e-mail: pj.herrera@csic.es, angela.ribeiro@csic.es)*

<sup>2</sup>*Institute for Sustainable Agriculture, CSIC, 14080 Córdoba, Spain*

**Keywords:** unsupervised clustering, RGB images, near infrared, remote images, site-specific weed control

---

**Abstract:** In precision agriculture, especially in weed control, it is essential to have accurate information about the weed distribution, i.e. a weed map. So a crucial task is the generation of accurate weed maps. This paper proposes a new automatic approach for identification of agricultural textures (crop and weed) in remote images using a non-supervised strategy based on the Fuzzy Clustering method. The strategy takes into account the relevance of the information based on the intensity variability by means of the following spectral components: Red, Green, Blue and Near Infrared. The proposed method shows a good performance for distinguishing weeds from wheat crop.

---

## **1. Introduction**

One important issue in agriculture is related to the automatization of tasks for reducing weed control measurements. Optical sensors provide images that must be conveniently processed. The most relevant image processing procedures require the identification of textures belonging to crop and weed plants, so that some types of strategies must be carried out, including site-specific treatments with chemical products or mechanical manipulations. In this context, textures can be useful for distinguishing weeds from crop. Different



classical techniques have been studied for image texture classification, namely: Bayesian, K-Nearest, Neural Networks, Vector Quantization (Frate et al., 2007, Hanmandlu et al., 2004, Lam, 2007), among others.

Image segmentation methods can be classified into pixel-based and region-based approaches (Pajares and Cruz, 2007). A pixel-based approach tries to classify each pixel as belonging to one of several classes. The region-based identifies patterns of textures within the image and describes each pattern by applying filtering (laws masks, Gabor filters, wavelets, etc.). The remote images used in this work do not display texture patterns. This implies that textured regions cannot be identified by applying region-based methods. In this research we propose to use a pixel-based approach under a Multispectral (Red - R -, Green - G -, Blue - B -, Near Infrared - NIR -) QuickBird satellite image as which shown in Fig. 1. RGB colour representation performs favourably against other colour mappings, as reported in Maillard (2003). Hence, the three RGB spectral values together to NIR band are the four features used in the study described in this paper.



Fig. 1. The multispectral QuickBird image (scene: 102 km )

So far, the identification of agricultural textures (crop and weeds) in aerial and satellite images has been realized by means of supervised strategies (De Castro et al., 2012, López-Granados, 2011) that require a costly field sampling. The aim of this work is the discrimination between weed and wheat crop textures using a non-supervising strategy. In this paper, the

design and develop of an unsupervised classification strategy based on the Fuzzy Clustering (FC) method is presented. The FC classification technique has been selected for being a successful tested method for segmentation in external environments (Guijarro et al., 2008, Pajares et al., 2009). Furthermore, the use of an unsupervised strategy avoids having to obtain ground-truth samples belonging to the textures object of interest.

## **2. Materials and methods**

Fuzzy clustering is a class of algorithms for cluster analysis in which the allocation of data points to clusters is not "crisp" (all-or-nothing) but *fuzzy* in the same sense as *fuzzy logic*. FC is a more statistically formalized method and discovers soft clusters where a particular point can belong to more than one cluster with certain probability. In FC, each point has a degree of belonging to clusters, as in fuzzy logic, rather than belonging completely to just one cluster. Thus, points on the edge of a cluster may belong to the cluster to a lesser degree than points in the centre of cluster. In fact, given the random and irregular nature of the textures object of this study, we sometimes find that the histograms of the intensity levels for different spectral bands belonging to textures show overlapping prominences. This implies that, in these cases, a given pixel or group of pixels may be classified either as belonging to more than one of the classes that define the texture and present overlap. That membership is determined by what is called in fuzzy logic precisely as membership degree. On other occasions, such histograms prominences are manifested separately, in whose case the pixels or pixel groups are unquestionably associated with a unique class of texture (Zimmermann, 1991).

Due to use an unsupervised strategy we avoid having to obtain field samples belonging to the texture object of interest. Thus, for the clustering phase, we have a number of unclassified samples and we only need to establish the number of classes in which the set of samples has to be split.



### 3. Results

The segmentation strategy was carried out over a Multispectral (Blue, B: 450-520 nm; Green, G: 520-600 nm; Red, R: 630-690; NIR: 760-900 nm) QuickBird satellite image (2.4 m pixel size and covers a scene of 103 km : 15.8 km x 6.5 km) in which six wheat fields were studied (118,912 samples in total): field *A* (27,835), field *B* (11,229), field *C* (17,114), field *D* (2,299), field *E* (38,493) and field *F* (21,942). This image with a 16 bit radiometric resolution was taken in March 2009 in an area located in the province of Cordoba (southern Spain, Fig. 1). Wheat fields cover a surface range from 6.79 ha to 23.03 ha and all of them were naturally and highly infested by cruciferous weeds (mainly *Diploaxis* spp and *Sinapis* spp).

Centres were estimated for the whole image and each field separately. In addition, the ground-truth was obtained for a subset of pixels from the satellite image through a sampling at the field. Thus, the correct class (crop or weeds) was known for a subset of pixels in each field according to the expert criteria. These data are essential to compute the performance of the proposed clustering approach. In fact the tests reported in this paper have been carried out only with the pixel subset of the image for which the ground truth is available. Therefore for each pixel, the difference between the class predicted by our system and the class assigned by the expert (ground truth) can be calculated, in other words, the success percentage (percentage of hits) of the proposed method can be estimated.

In a previous study, R, G, B and NIR spectral components were separately selected as well as all possible combination of these four components (R-G-B, R-G-NIR, R-B, R...). The objective was to identify the best and worst spectral components or combination of them for discriminating weed from crop pixels. According to the results obtained in that study, it has been selected the combination of the four components shown in Table 1 since they have been the most promising. Besides, ground-truth pixels available for each field are also shown. Table 1 summarizes the percentage of hits of the proposed approach compared to the available ground truth. In the context of the

presented work, an error in the weed classification is worse than in the crop classification, since it leads to weed patches without control treatment and, therefore, to potential decreases of the crop yield. According to the results obtained, the best results are achieved when the NIR component is present (named N in Table 1). Also, NIR component combined with G and B present good results in general. One can see that the number of ground truth pixels available in fields B, C and D for crop and weed classes is not proportional. For this reason, a relevant conclusion cannot be obtained in these fields.

Table 1. Average percentage of hits for the whole image and the six wheat fields separately

Field	Samples	Best combination of components			
All	Crop (1340)	G-N	49.15	N	51.84
	Weed (728)		75.70		73.99
A	Crop (324)	G	99.69	N	58.95
	Weed (117)		31.62		91.45
B	Crop (259)	G-N	97.30	N	88.42
	Weed (48)		83.33		87.50
C	Crop (20)	G-N	100	N	100
	Weed (359)		62.39		64.90
D	Crop (136)	G	99.26	B	100
	Weed (14)		42.86		35.71
E	Crop (560)	G	99.64	N	79.82
	Weed (154)		14.93		81.17
F	Crop (41)	B-N	78.05	N	78.05
	Weed (36)		52.78		52.78

#### 4. Conclusions

The novelty of this work is mainly related to the image segmentation task and its potential extrapolation to other remote imagery and crops. The discrimination between crop and weeds is achieved by a strategy based on a Fuzzy Clustering method. By proposing an unsupervised classification method, weed pixels are distinguished from crop pixels, without a previous step that is time consuming and requires an expensive field



sampling, as in the case of supervised classification methods. This makes an important contribution. The performance of the method allows verifying its viability for automatic tasks in agriculture based on remote image processing.

Finally, the discrimination in more than two classes is proposed as future work. The aim will be to classify correctly those pixels which do not belong to crop and weed classes, e.g. bare soil, buildings and manmade structures, in a third, fourth and fifth classes.

### Acknowledgements

*The Spanish Government has supported this research through projects AGL 2011-30442-C01 and AGL 2011-30442-C02. The authors wish to acknowledge to the CSIC and the ESF for the JAE-Doc contract with the first author. The research of the second author was financed by CSIC-FEDER funds (JAEPre-Program).*

### References

- De Castro, A.I., M. Jurado-Expósito, J.M. Peña-Barragán and F. López-Granados. (2012). Airborne multi-spectral imagery for mapping cruciferous weeds in cereal and legume crops. *Precision Agriculture*, 13, 302-321.
- Frate, F., F. Pacifici, G. Schiavon and C. Solimini. (2007). Use of Neural Networks for Automatic Classification from High-Resolution Images. *IEEE Trans. Geoscience and Remote Sensing*, 45, 800–809.
- Guijarro, M., G. Pajares and P.J. Herrera. (2008). *On Combining Classifiers by Relaxation for Natural Textures in Images*. In E. Corchado, A. Abraham, and W. Pedrycz (Eds.) HAIS, LNAI 5271, pp. 345-352.
- Hanmandlu, M., V.K. Madasu and S. Vasikarla. (2004). *A Fuzzy Approach to Texture Segmentation*. In Proc. IEEE Int. Conf. Information Technology: Coding and Computing ITCC (pp. 636–642). The Orleans, Las Vegas, Nevada.
- Lam, E.P. (2007). *Wavelet-based Texture Image Classification Using Vector Quantization*. In J.T. Astola, K.O. Egiazarian, & E.R. Dougherty (Eds.) Proc. SPIE, Image Processing: Algorithms and Systems V, vol. 6497 (pp. 687–696).
- López-Granados, F. (2011). Weed detection for site-specific weed management: mapping and real-time approaches. *Weed Research*, 51, 1-11.
- Maillard, P. (2003). Comparing Texture Methods through Classification. *Photogrammetric Engineering and Remote Sensing*, 69, 357–367.
- Pajares, G., and Cruz, J.M. (2007). *Visión por Computador: Imágenes digitales y aplicaciones* (2nd ed.). Madrid: RA-MA.
- Pajares, G., M. Guijarro, P.J. Herrera and A. Ribeiro. (2009). Combining classifiers through fuzzy cognitive maps in natural images. *IET Computer Vision*, 3, 112–123.
- Zimmermann, H.J. (1991). *Fuzzy Set Theory and Its Applications*. Kluwer Academic Publishers: Norwell, MA, USA.



## Topic 2.2

### Discrimination of crop rows using object-based analysis in uav images for early site-specific weed management in maize fields

J. M. Peña-Barragán<sup>1</sup>, M. Kelly<sup>2</sup>, A. I. De-Castro<sup>1</sup>,  
and F. López-Granados<sup>1</sup>

<sup>1</sup>*Institute for Sustainable Agriculture, IAS-CSIC, Cordoba (Spain).*

<sup>2</sup>*University of California, Berkeley, CA (USA).*

**Keywords:** image segmentation, OBIA, precision agriculture, weed seedling patches discrimination

---

**ABSTRACT:** In the context of weed detection in crop-fields for site-specific weed control, the first step is to identify and count crop rows for a further successful discrimination of weeds. In this work, an accurate object-based image analysis (OBIA) methodology based on a looping procedure has been developed for the classification of crop rows in a maize field at early phenological stage. The rule-set algorithm combined several contextual, hierarchical and object-based features and reached very satisfactory results.

---

## INTRODUCTION

Current agricultural production requires the use of herbicides as an essential tool to maintain the necessary quality and quantity of agricultural production demanded by the population. Costs on herbicides rose in 2008 in the European Union to €3510 M, compared to €3900 M for insecticides and fungicides together ([www.aepla.es](http://www.aepla.es)). Associated environmental and economic concerns in different administrative areas have led to the creation of European policy such as Directive 1107/2009 (Directive 2009) for the Commercialisation of Crop Protection Products and Regulation 2009/128/EC (Regulation 2009) for the Sustainable Use of Pesticides. This Directive





includes such key elements as reductions in applications and the utilisation of adequate doses according to the weed infestation. Both components are part of the agronomical basis of site-specific weed management (SSWM), in particular, those methods based on herbicide application. These SSWM methods consist of customising herbicide treatments depending on the zone infested (weed spatial position), presence-absence of weeds or groups of weed seedlings (*e.g.* grass *vs* broad-leaved or herbicide-resistant weeds) (Srinivasan, 2006).

Remote sensing technology is a major source to obtain crop spatial information and to create timely and accurate weed infestation and control maps to be used by site-specific machinery or by a fleet of autonomous robots (López-Granados, 2011; López-Granados et al., 2006). The new generation of remote platforms known as Unmanned Aerial Vehicles (UAV), are specially appropriate for SSWM because they can operate at low altitudes and, thus, capture images at the very-high spatial resolution needed for distinguishing the weed seedlings at early stages for in-season post-emergence treatments. Classification methods based only in pixel information are very limited when spectral properties of weeds and crop are very similar. To solve this limitation, object-based image analysis (OBIA; Blaschke, 2010) might be the optimum way to discriminate both classes. OBIA identifies spatially and spectrally homogenous units (*objects*) created by grouping adjacent pixels according to a procedure known as *segmentation*, which allows to obtain, firstly, an image with vegetation (crop and weeds) and soil background, and then, zones corresponding to crop plants and weeds (Burgos-Artizzu et al., 2009).

In early phenological stages, the main potential to differentiate weed characteristics are position-localisation, form, texture and size of weeds when they emerge between the crop rows. This is especially effective in crops with clearly separated rows (such as maize). Therefore, this work describes an OBIA method developed for the automatic definition of crop rows within a maize field in early-season, in which several object and

contextual features such as object shape, main direction, angle between objects and relative position between objects are combined to define a looping rule-set algorithm. This is the first step for a further discrimination and mapping of weeds found in the maize field.

## MATERIALS AND METHODS

A set of aerial images was taken in 2011 on a maize field located in Arganda (Madrid, Spain) just when post-emergence herbicide or other control techniques are recommended (mid-May in the site conditions). The maize field was naturally infested by *Amaranthus blitoides* (broad-leaved weed) and *Sorghum halepense* (grass weed; Fig. 1a). The images were collected with a 6-channel multispectral camera model Tetracam mini-MCA (Tetracam Inc., CA, USA; Fig. 1b) mounted in an UAV model microdrone md4-1000 provided with autonomous system for waypoint navigation (Fig. 1c). The flight altitude was 30 m above ground level, yielding 16 images ha<sup>-1</sup> of 2-cm spatial resolution (Fig. 1d). The channels were configured with independent bandpass filters (Andover Corporation, NH, USA) with centre wavelengths at 530, 550, 570, 670, 700, and 800 nm.

The eCognition Definiens software was used to segment the multi-band images and to develop the rule-set algorithm for the detection of the crop rows. The procedure combines several scene-, contextual- and object-based features derived from: 1) field structure, 2) crop pattern and orientation, 3) hierarchical relationships based on different segmentation scales, 4) neighbouring relationships based on distance, position and angle between objects, and 5) plant (crop and weeds) characteristics, such as spectral properties (NDVI values) and plant dimensions. To evaluate the algorithm, an on-ground sampling consists of placing 49 square frames (1 x 1 m) in a grid of 12.5 x 12.5 m was carried out (Fig. 1d, upper right corner in white). Every frame was photographed and georeferenced in order to record weed cover and weed species emergence.

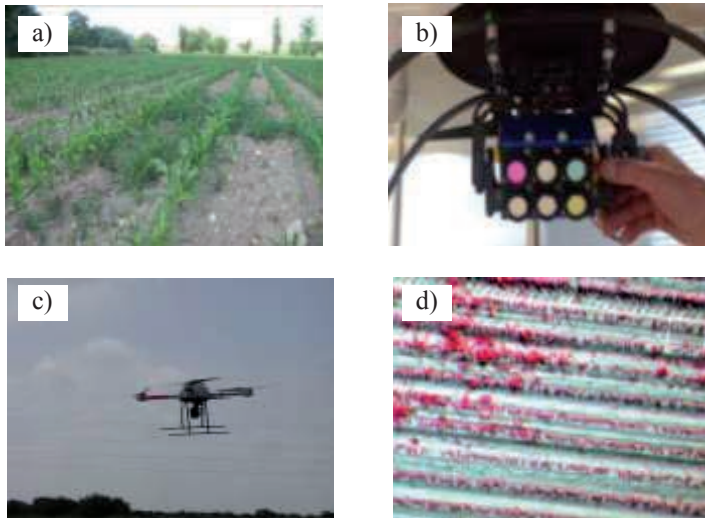

Fig. 1. a) Patches of grass weed seedlings (*Sorghum halepense*) in maize crop; b) 6-channel multispectral camera; c) UAV flying; d) aerial image (color-infrared composition) collected by the UAV at 30 m altitude, showing a sampling square frame (upper right corner in white).

## RESULTS

The OBIA procedure developed for the identification and classification of crop rows was divided into the next phases:

1) Calculation of row orientation: This parameter was computed from the statistical value "mean of main-direction" of all the objects segmented at the upper level (scale 100).

2) Discrimination between objects of vegetation and bare-soil: The image was then sub-segmented to a lower level (scale 10) and the objects were classified according to NDVI values. In this case, vegetation objects were attributed to  $NDVI \geq 0.2$ , and bare-soil to  $NDVI < 0.2$  (Fig. 2a).

3) Identification and classification of crop rows: A looping process was built to define one row after another. Firstly, a seed-object belonging to each crop row is selected and, afterwards, the complete row is drawn by following the row orientation. Previously, a customized merging operation was performed between vegetation-objects that fulfil the next rule: two

candidate vegetation-objects are merged only if the length/width ratio of the target object increases after the merging. Next, the seed-object within each row is selected for being the largest vegetation-object whose main-direction was the closest to the row orientation. Finally, the seed-object grows in both directions by performing a looping merging process in which every candidate object is selected for having the angle to the seed-object closest to the row orientation angle. To avoid infinite looping, each row must be separated by a gap between each other defined by the crop planting distance (*e.g.*,  $75 \pm 15$  cm in maize crops), which makes the algorithm to finish when the last row reaches the limits of the parcel (Fig. 2b).

The algorithm identified and counted the maize rows with 100% accuracy, except in the extreme of some of the images mainly due to the short size of rows (Fig. 2c). Weeds were successfully discriminated (accuracy higher than 95%) in low weed infestation frames; however decreased in frames with moderate or high weed infestation (research still in progress)

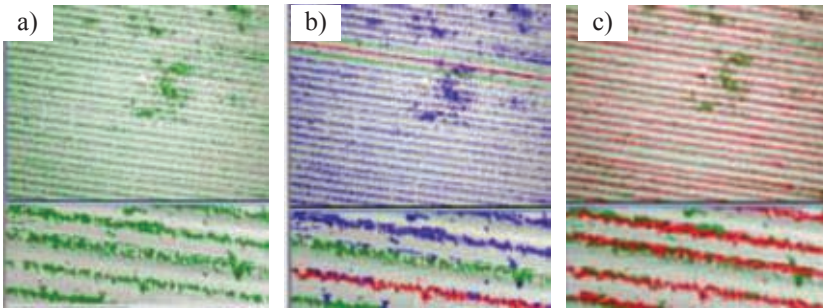

Fig. 2. Partial views of the outputs obtained from the eCognition Developer 8 software working the rule-set algorithm: a) classification of objects corresponding to vegetation (crop and weeds, in green) and bare soil (in white); b) the objects within the crop row are merged to create a single object (in red), gap defining the crop planting distance (in green) and rest of the crop (in blue); c) final classification: weeds (in green), crop row (in red) and bare soil (in white).



## CONCLUSIONS

The OBIA procedure was able to classify crop rows by means of: 1) calculation of row orientation; 2) discrimination between objects of vegetation and bare-soil according to NDVI values; and 3) identification and classification of crop rows by combining several scenes, contextual, hierarchical and object-based features in a looping structure. Next investigations will go on the detection and mapping of small weed and crop plants.

## Acknowledgements

*This research was partly financed by Projects AGL2011-30442-CO2-01 (MINECO, FEDER Funds) and RHEA (NMP-CP-IP 245986-2, EU-7<sup>th</sup> Frame Program); research of Dr. Peña-Barragán and Ms. de Castro was co-financed by CSIC and FEDER funds (JAEDoc and y JAEPRe Programs, respectively). Authors thank to Dr. Kelly for providing her laboratory facilities at University of California (Berkeley, USA), and Juan J. Caballero-Novella for his valuable help in the field work.*

## References

- Aepla: [www.aepla.es](http://www.aepla.es). Asociación Española de Plaguicidas (Spanish Soc. Pesticides).
- Blaschke, T. (2010). Object based image analysis for remote sensing. *ISPRS Journal of Photogrammetry and Remote Sensing*, 65, 2-16
- Burgos-Artizzu, X. P., A. Ribeiro, A. Tellaache, G. Pajares and C. Fernández-Quintanilla (2009). Improving weed pressure assessment using digital images from an experience-based reasoning approach. *Computers and Electronics in Agriculture*, 65, 176-185.
- Directive 2009/128/EU of the European Parliament and of the Council of 21 and October (2009). *Establishing a framework for Community action to achieve the sustainable use of pesticides*. Web Page: <http://eur-lex.europa.eu>.
- López-Granados, F., M. Jurado-Expósito, J. M. Peña-Barragán and L. García-Torres. (2006). Using remote sensing for identification of late-season grass weed patches in wheat. *Weed Science*, 54, 346-353.
- López-Granados, F. (2010). Weed detection for site-specific weed management: mapping and real time approaches. *Weed Research*, 51, 1-11.
- Regulation (2009). Regulation EC no 1107/2009 of the European parliament and of the Council of 21 and October (2009). *Concerning the placing of plant protection products on the market and repealing Council Directives 79/117/EEC and 91/414/EEC*. Web page: <http://eur-lex.europa.eu>
- Srinivasan, A. (2006). Precision Agriculture: An Overview. In: *Handbook of Precision Agriculture: Principles and Applications*. (ed. A. Srinivasan), Food Products Press. The Haworth Press. New York, 3-18.



TOPIC n° 2.2

## IMPROVING OF GEOREFERENCING ACCURACY IN UAV REMOTE IMAGERY

Juan J. Caballero-Novella<sup>1</sup>, Francisca López-Granados<sup>1</sup>,  
David Gómez-Candón<sup>1</sup>, Ana I. De-Castro<sup>1</sup> and Luíís García-  
Torres<sup>1</sup>

<sup>1</sup> *Institute for Sustainable Agriculture, IAS-CSIC, Cordoba (Spain).*

**Keywords:** *UAV, precision agriculture, georeferencing, remote sensing*

---

**Abstract:** This work aims to determine the georeferencing errors in the UAV imagery, explaining their origin and how they can be managed. Most commercial remote sensing imagery is already georeferenced via aerotriangulation, which normally inherit a geoposition error of about 2-5 meters. The terrain slope, the type of GPS carried by the UAV, and even the device movement are factors that affect the position error in the coordinates. A study was conducted in Cordoba (Spain) to work out a co-registration method for improving such geographic information, using artificial ground control points placed on the ground, an own-developed software and a DGPS receiver which provides much more accurate positioning data than the present in the default remote images. This whole system, known as AUGEO, manages to decrease the errors from 5.2m to 0.9m and from 18.8m to 3.9 m for two UAV images, with the additional advantage of achieving it in areas where no remarkable hard points are available.

---





## **1. Introduction**

A sustainable use of herbicide is a main goal of site-specific weed management (SSWM), and Remote imagery has turned into an extremely helpful resource for this purpose. Unmanned Aerial Vehicles (UAV), the newest generation of remote platforms, provide a spatial resolution lesser than 20 cm, which is required for discriminating weeds and crops. However, although high spatial resolution makes easier the characterization of weed infestations and the subsequent delineation of Input Prescription Maps, the enhancement in detail adds an additional challenge: the need for a better georeferencing.

No matter the device performing the caption, there is always a degree of error in the Global Position System (GPS) data of remote images. This is also true for UAV and, due to the accuracy demanded by the SSWM strategies in which this kind of aircrafts are involved, it is critical to nullify any deviation as much as possible. A semi-automatic georeferencing system of high spatial resolution remote imagery has been developed using Artificial Terrestrial Targets (ATT) and a software called Automatic Georeferentiation® (AUGEO®). This system works by placing some georeferenced ATT on the ground, which are captured in the imagery and found by the AUGEO software based on the difference between their spectral band and the surrounding land uses. The ATT geographic coordinates interact with the map registration menu of ENVI and the image is georeferenced or coregistered.

## **2. Materials and methods**

### **2.1 Locations and imagery**

UAV images, each sized about 50 ha, of Dehesa and Navajas farms in the province of Cordoba (Andalusia, Southern Spain) were taken on 23 November 2008 using a vehicle 100 m above the ground, with a multispectral camera model MCA-6/TETRACAM, providing NIR, R and G spectral-bands images, with a spatial resolution of 0.10 m, unless otherwise. The ground



of Dehesa is flat (slope <1%), and that of Navajas is uneven, with slopes between 2% and 9%. Land uses were typically representative of the region, such as citrus and olive orchards, corn, cotton, wheat, sunflower, broad beans, tilled soil, rivers, riparian trees, pavement and bare roads, and civil buildings, among others.

## **2.2 Artificial Terrestrial Targets**

To determine the error existing on the images, several ATT were crafted as a mean of having Ground Control Points (GCP) with near to zero dependence of the terrain, environmental and urban features. Each ATT consisted of a 1.0 m<sup>2</sup> hexagonal tarp) placed in the farms, with no part of them beneath vegetation or near tall vegetation (>1 m) thus avoid shadowing, and geo-referenced using a DGPS Trimble PRO-XRS. These DGPS data were post-processed via Trimble GPS Pathfinder, prior download of the proper RINEX. A total of 32 ATT were placed in selected areas, 25 for georeferencing and 7 for validation, (Fig. 2). The number of ATT on needed for an efficient geo-referencing and co-registration has been already studied (Gómez-Candón et al., 2011)

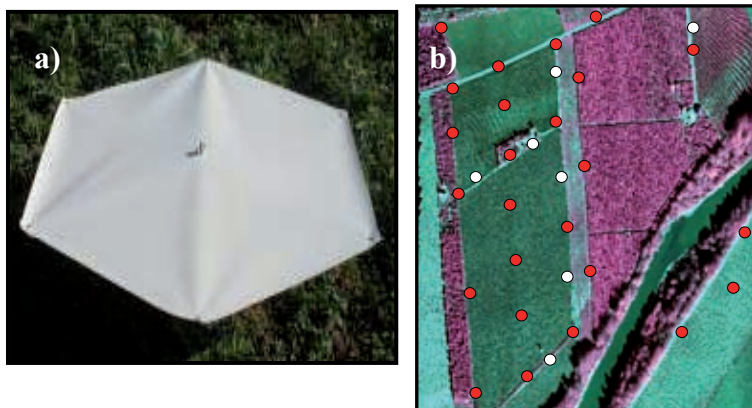

Fig. 1. a) Artificial Terrestrial Target opened and placed in field.  
b) Deployment of ATT at Dehesa farm. Red circles show the tarps used for georeferentiation (25 of them) and white ones the used for validation (7 of this kind).



### 2.3 AUGEO software and processing

AUGEO was conceived as an add-on for ENVI, a widely used image processing software. It receives as input data the file generated by the DGPS and a few Regions of Interest (ROIS) which pinpoint ATTs at know locations, giving as output all the ATTs placed in the whole image and their estimated coordinates. These found ATTs are then given to the Co-registration menu in ENVI, thus co-registering the remote image.

### 2.4 Co-registration accuracy

The difference in location between the GCP on the co-registered layer and base layer is often represented by the total root mean square error (RMSE), a metric-based Pythagorean Theorem, and calculated for a coordinate point by the equation (Slama et al., 1980)

$$RMSE = [(X_s - X_r)^2 + (Y_s - Y_r)^2]^{1/2},$$

where  $X_s$  and  $Y_s$  are geospatial coordinates of the point on the source image, and  $X_r$  and  $Y_r$  are coordinates of the same point on the co-registered image. The RMSE for an image with  $n$  validation points is assessed as following (ERDAS, 1999):

$$RMSE = \left[ \sum_{i=1}^n [(X_s - X_r)^2 + (Y_s - Y_r)^2] / n \right]^{1/2}$$

## 3. Results and conclusions

The experiments performed have shown several degrees of position error between the GPS data in the commercial images and points geo-referenced by a DGPS on field. An additional co-registration system, AUGEO, was developed to lessen these differences.

Georeferencing errors using AUGEO were considerably lower than those provided originally by the aerotriangulation (ATRI) method (Table 1). Root Mean Square Error (RMSE) for the AUGEO and ATRI systems was respectively 0.9 m / 3.9 m for Dehesa and 5.2 m / 18.8m for Navajas. The uneven topography

in Navajas is likely the cause of accounting for higher georeferencing errors as compared to Dehesa, as lower flight altitude leads to greater terrain deformations (Schowengerdt, 2007). As a potential solution to decrease the errors in Navajas we tried introducing the Spanish digital elevation model (DEM), as this is suggested by some authors to be a way for decreasing image georeferentiation/ coregistration discrepancies, mainly in uneven altitude landscapes (Borkowski and Meier, 1994; Kienzle, 2004). However, the results were very poor likely due to the fact that Spanish DEM showed differences of 10 m and also had a spatial resolution about 10 m, which certainly does not fit with the high-spatial-resolution images we have used. Precise DEMs are likely needed to improve the geographic positioning systems.

Table 1) Georeferencing errors of the UAV images of Dehesa and Navajas georeferenced through the AUGEO system and aerotriangulation (ATRI).

<b>Dehesa</b>	AUGEO			ATRI		
	$\Delta X$	$\Delta Y$	RMSE	$\Delta X$	$\Delta Y$	RMSE
1	-1.13	0.05	1.13	-2.45	0.18	2.46
2	-0.86	-0.22	0.88	-1.97	0.11	1.97
3	-0.53	-0.14	0.55	-0.75	0.69	1.02
4	0.37	0.66	0.76	-1.35	-0.91	1.62
5	0.22	0.90	0.92	0.10	1.53	1.53
6	-1.45	-0.06	1.45	0.03	9.67	9.67
7	-0.03	0.61	0.61	-0.55	-0.56	0.78
Overall			0.95			3.97
( $\pm$ s.d.)			0.31			3.11



Navajas	AUGEO			ATRI		
	$\Delta X$	$\Delta Y$	RMSE	$\Delta X$	$\Delta Y$	RMSE
1	9.02	-4.10	9.91	8.20	-5.48	9.87
2	5.25	0.21	5.25	2.83	-8.37	8.83
3	1.61	-4.44	4.72	-1.16	-18.42	18.46
4	3.17	-3.73	4.89	0.55	-24.41	24.42
5	-2.03	-1.76	2.68	-7.00	-22.99	24.03
6	-2.48	2.32	3.40	-10.30	-16.76	19.67
7	-1.61	0.64	1.73	-11.68	-16.14	19.92
Overall			5.26			18.80
( $\pm$ s.d.)			2.65			6.25

Abbreviations: VT: verification targets;  $\Delta X$ ,  $\Delta Y$ : differences in meters between AUGEO and ATRI; RMSE: coregistration root mean square error in meters.

## Acknowledgements

*This research was partially financed by the Spanish Ministry of Science and Innovation through the projects AGL2007-60926 and AGL2010-15506.*

## References

- Borkowski A., Meier S. (1994). *A procedure for estimating the grid cell size of digital terrain models derived from topographic maps*. Geo-Information-System, 7 (1), 2–5.
- ERDAS Inc. (1999). *RMS error, page 362-365, in ERDAS Field Guide*. 5th Edition. Atlanta, Georgia, 672 pp.
- Gómez-Candón D., López-Granados F., Caballero-Novella J. J., Gómez-Casero M. T., Jurado-Expósito M. and García-Torres L. (2011). *Geo-referencing remote images for precision agriculture using artificial terrestrial targets*. Precision Agriculture, Volume 12, Number 6 (2011), 876-891, DOI: 10.1007/s11119-011-9228-3
- Slama, C. C., Theurer, C., & Henriksen, S. W. (1980). *Manual of Photogrammetry*. (4th edn. ed.) *The American Society for Photogrammetry and Remote Sensing, 5410 Grosvenor Lane, Suite 210, Bethesda, MD 20814-2160, USA*
- Kienzle S. (2004). *The effect of DEM raster resolution on first order, second order and compound terrain derivatives*. Transactions in GIS, 8 (1), 83–112.
- Schowengerdt R. (2007). *Topographic distortion, page 121-124, in Remote sensing: models and methods for image processing*. 3rd edition. Academic Press, New York, 560 pp.



TOPIC n° 2.2

**Mosaicking UAV imagery for precision agriculture  
purposes: effect of flying altitude**

**David Gómez-Candón<sup>1</sup>, José M. Peña-Barragán<sup>1</sup>, Ana I. de-  
Castro<sup>1</sup>, Francisca López-Granados<sup>1</sup>**

<sup>1</sup>*Institute for Sustainable Agriculture, CSIC, Córdoba (Spain), (dgomez@ias.csic.es)*

**Keywords:** Image mosaicking, precision agriculture, UAV

---

**Abstract:** The UAV ortho-mosaics are turning into an important tool for the development of precision agriculture prescription strategies, in particular for site specific weed management (SSWM). The UAV platforms are able to take remote images at a very high spatial resolution. This high spatial resolution is necessary for SSWM at early grow stages which requires to discriminate small plants (crops and weeds) that can not be detected using other kind of remote platforms.

Little changes in flight altitude can cause important differences in the final spatial resolution. Furthermore, a decrease of the flying altitude reduces the area covered by each single image; which implies an increment of both the sequence of images and the complexity of the image mosaicking to obtain a cover of the whole study area. On the other hand, prescription control maps need geo-referenciation accuracy in agreement to the details of the objectives that we want to discriminate. Consequently, it is necessary to find a balance between spatial resolution (which depends on flying height and kind of sensor) and geo-referenciation accuracy. This study investigated the geometric accuracy differences among ortho-mosaics created from UAV images series taken at three different flight altitudes (30, 60 and 100 m). Results did not show relevant differences in geo-referenciation accuracy on the interval studied, so that, the most important parameter to take into account when choosing the flying altitude is the needed spatial resolution rather than the geo-referenciation accuracy.

---

## 1. Introduction

Agricultural fields present an enormous variability on weed spatial distribution and abundance. Precision agriculture, and particularly site-



specific weed management (SSWM), has been defined to take into account the spatial variability of biotic factors such as weeds and to apply control measures fitted to the needs of each small-defined area (Blackmore, 1996; Kropff et al., 1997). Usually, to implement SSWM strategies, it is necessary the use of prescription maps. One of the most recently approaches for the acquisition of crop and weed spatial information is through remote images, which can be classified and divided in a series of sub-plots for further personalized applications according to the specific weed emergence (López-Granados, 2011; Gómez-Candón, 2012).

One of the most important variables of remote imagery is the spatial resolution. The higher the spatial resolution, the smaller details will be discriminated in the image. So, it is essential to select the appropriate spatial resolution to identify and analyze the objects of interest, weeds in our case, and finally to obtain accurate prescription maps. Recently, unmanned aerial vehicles (UAVs) have been presented as a promising tool for many agronomic applications (Schmale et al., 2008). The advantages of using a UAV over a piloted aircraft include lower image acquisition costs than from manned aircraft, the ability to deploy the aircraft relatively quickly and repeatedly for change detection and the ability to fly at a very low altitude (Rango et al, 2006).

Due to the low payload capability of most small UAVs, imagery is often acquired with low-cost, off-the shelf digital cameras (Rabatel et al, 2011). Imagery from those cameras has greater distortion compared to imagery from mapping cameras, and a camera calibration is required to determine the camera's interior orientation parameters. If sufficient ground control points of good accuracy are available, a self-calibrating bundle adjustment can be performed (Wu et al, 2007). Furthermore, the higher altitude, the lower spatial resolution will be obtained in the images. As a result of its intrinsic characteristics, UAV images (taken at low altitude) can not cover the whole study plot, this causes the need to take a sequence or series of multiple images (i.e. about 30-100 frames/ha). These images must be orthorectified and mosaicked to create an accurately geo-referenced orthoimage of the entire plot. This geo-registration process is very useful in UAV to navigate, or to geolocating a target, or even to refine a map (Lin & Medioni, 2007). Although the UAV imagery can offer a very high resolution (~2.5 cm pixel resolution at a flying height of 100m above ground), the image

footprint is relatively small (100 m x 75 m), and the images have to be stitched together to create a mosaic for further analysis and classification.

Thus, the aim of this paper was to study the geo-referenciation accuracy of image mosaics taken in wheat crops using UAV flying at different altitudes.

## **2. Materials and methods**

The studies were conducted in the province of Seville in Andalusia (Southern Spain). Two wheat plots of about 1 ha were selected, named Monclova and Infantado. The geographic coordinates (Universe Transverse Mercator System, zone 30 North) of the upper left corner of the images were  $X = 295627$  m,  $Y = 4158205$  m; and  $X = 295800$  m,  $Y = 4157498$  m, respectively. The ground is flat (average slope  $<1\%$ ). At the study plots, the images were taken from a MICRODRONES MD4-100 UAV (Fig. 1) equipped with an Olympus EP-1 camera (Red, Green and Blue bands). Wheat crop was naturally infested by broadleaved and grass weeds at all plants were at seedling growth stage (2-3 true leaves). Over the whole field, a total of 37 artificial GCPs (Ground Control Points, formed by  $0.40$  m<sup>2</sup> squared targets) were placed using a grid of about  $12.5 \times 12.5$  m, and every GCP was then geo-referenced using a Trimble Geo-XH DGPS ( $0.30$  m accuracy). Up to 30 GCPs were used for the orthorectification and 7 GCPs for the validation process to estimate the accuracy of the orthorectification and mosaicking procedure.



Fig. 1. UAV used, left and Ground base station, right.

A series of 30, 45 and 100 images corresponding to 100, 60 and 30 m flying altitudes (2.47, 1.48 and 0.74 cm spatial resolution, respectively), were taken and processed in order to orthorectify and mosaic them





using Leica Photogrammetry Suite (LPS) software to create a unique orthoimage of every wheat field. Once the orthoimages were generated, the root mean square error (RMSE) was calculated using the validation GCPs in order to assess the accuracy of the orthoimage.

### 3. Results and discussion

Three UAV remote image series at two different locations were taken, orthorectified and mosaicked (Fig. 2). Overall RMSE was lower than DGPS accuracy (0.30 m) in each location and flight altitude (Table 1). Furthermore, overall errors were very similar between ortho-mosaics regardless of the flight altitude and ranged from 0.21 to 0.28 m and 0.08 to 0.28 m for Monclova and Infantado, respectively.

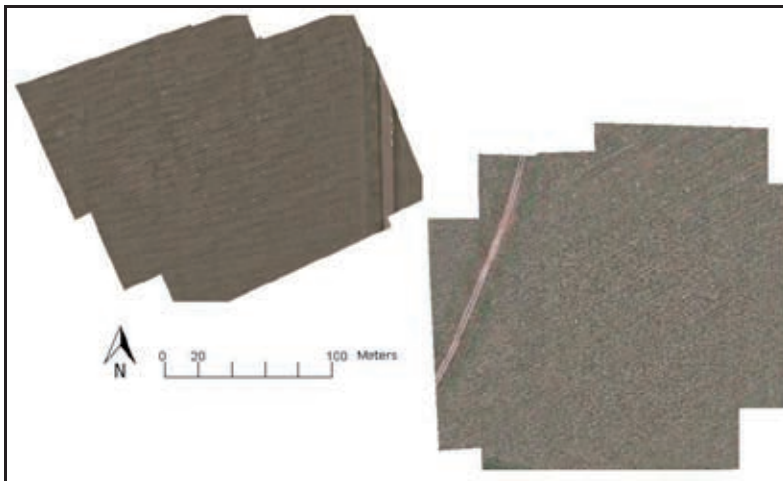

Fig. 2. Mosaicked images of Monclova (left) and Infantado (right)

Results did not show remarkable accuracy differences on the interval of altitude studied (30-100 m). Therefore, one of the relevant results of our study is that flying altitude did not affect the geo-referenciation accuracy of the mosaicked image. Discarding the altitude as a cause of error, there are other factors that could have been involved in the geo-referenciation accuracy, like number of GCPs, use of Digital Elevation Models (DEM), DGPS accuracy and sensor and aerial platform characteristics. Regarding to the number of GCPs used in the orthorectification process, in this study the same number of GCPs than single images has been used. It is expected that an increment in the number of GCPs will improve the geo-referenciation accuracy (Gómez-Candón et al, 2011).

Table 1. RMSE of Monclova and Infantado plots at different flying altitudes

Location	VGCP	Flight altitude								
		100 m			60 m			30 m		
		$\Delta X$	$\Delta Y$	RMSE	$\Delta X$	$\Delta Y$	RMSE	$\Delta X$	$\Delta Y$	RMSE
Monclova	1	0.051	0.105	0.117	-0.325	-0.338	0.469	-0.119	-0.494	0.508
	2	-0.019	-0.148	0.149	0.081	0.195	0.211	0.019	0.005	0.019
	3	0.557	0.027	0.557	0.041	0.112	0.119	0.091	-0.085	0.125
	4	-0.067	-0.252	0.261	0.297	-0.033	0.299	-0.067	0.006	0.067
	5	-0.039	0.126	0.132	0.041	0.076	0.086	-0.032	0.085	0.091
	6	-0.328	-0.098	0.342	-0.071	-0.056	0.090	-0.130	0.076	0.150
	7	-0.002	0.145	0.145	0.018	0.185	0.186	0.014	-0.037	0.040
	Overall ( $\pm$ s.d.)			0,285 0,161			0,244 0,137			0,211 0,167
Infantado	1	0,089	-0,077	0,118	-0,257	-0,016	0,258	-0,057	-0,046	0,074
	2	-0,119	-0,124	0,171	-0,237	0,170	0,292	0,009	-0,077	0,077
	3	0,130	0,240	0,273	-0,316	-0,108	0,334	-0,114	-0,048	0,124
	4	0,099	0,148	0,178	0,166	-0,246	0,297	-0,012	0,037	0,038
	5	-0,099	0,282	0,299	-0,088	-0,214	0,231	0,036	0,083	0,090
	6	-0,103	0,216	0,239	-0,231	-0,297	0,376	0,020	0,070	0,073
	7	0,153	0,014	0,153	-0,058	0,019	0,061	0,049	0,018	0,052
	Overall ( $\pm$ s.d.)			0,214 0,067			0,280 0,101			0,080 0,027

Abbreviations: VGCP: validation GCPs;  $\Delta X$ ,  $\Delta Y$ : geo-referenciation differences (in metres) between the DGPS and the orthorectified image.

The study was placed in a flat terrain (<1% slope); thus, no DEM was used. However, the high spatial resolution involved could imply the use of very accurate DEM in other fields with higher slope. This could be a work line into future studies in which fields with different kind of slopes can be included. In addition, some single images of the series were fuzzy due to the sensor and aerial platform characteristics (e.g. vibrations during image taken) and it was not possible to clearly indentify GCPs and tie points on them. Concerning to the DGPS accuracy, the theoretical accuracy of the DGPS used for this study was 30 cm; so that, every GPS measurement includes its intrinsic error to every GCP measured.

### 3. Conclusions

Flight altitude is an important parameter to take into account when acquiring remote images. However, there are no accuracy differences in the ortho-mosaics created by UAVs flying between 100 and 30 m



height. For this reason, when choosing the right flying altitude, there are two parameters more crucial than image errors: the first one is the optimum spatial resolution needed to discriminate between weeds and crops, and the second one is the number of single images required to include the entire area, particularly whether a high amount of single images make harder orthorectification and mosaicking processes.

## Acknowledgements

*This research was partly financed by AGL2011-30442-CO2-01 Project (Spanish Ministry of Economy and Competition, FEDER Funds) and RHEA Project (ref.: NMP-CP-IP 245986-2, EU-7th Frame Program); research of Dr. Gómez-Candón was financed by RHEA project; research of Dr. Peña-Barragán and Ms. de Castro was co-financed by CSIC and FEDER funds (JAE-Doc and JAE-Pre Programs, respectively). Authors thank Mr. Caballero-Novella his very helpful software support and field-work assistance.*

## References

- Blackmore, S., 1996. An information system for precision farming. *Conference on Pests and Diseases, Brighton, UK*, 3, 1207-1214.
- Gómez-Candón, D., López-Granados, F., Caballero-Novella, J.J., Gómez-Casero, M.T., Jurado-Expósito, M. and García-Torres, L. 2011. Geo-referencing remote images for precision agriculture using artificial terrestrial targets. *Precision Agriculture*. Vol. 12, 6. 876- 891.
- Gómez-Candón, D., López-Granados, F., Caballero-Novella, J.J., García-Ferrer, A., Peña-Barragán, J.M., Jurado-Expósito, M., García-Torres, L. 2012. Sectioning remote imagery for characterization of Avena sterilis infestations. Part A: Weed abundance, *Precision Agriculture*, Vol. 13, Num. 3, 322-336
- Kropff, M. J., Wallinga, J., Lotz, L. A. P. 1997. Crop-weed interactions and weed population dynamics: current knowledge and new research targets. *Proceedings of the 10th Symposium of the European Weed Research Society (EWRS)*, 22–26 June 1997, Poznan, Poland. 41–48.
- Yuping Lin and Gerard Medioni. 2007. Map-Enhanced UAV Image Sequence Registration and Synchronization of Multiple Image Sequences. 1-4244-1180-7/07
- López-Granados, F., 2011. Weed detection for site-specific weed management: mapping and real-time approaches. *Weed Research*, 51, 1-11.
- Rabatel, G., Gorretta, N., Labbé, S. 2011. Getting NDVI Spectral Bands from a Single Standard RGB Digital Camera: A Methodological Approach. *Lecture Notes in Computer Science*. Vol 7023, 333-342.
- Rango, A., Laliberte, A.S., Steele, C., Herrick, J.E., Bestelmeyer, B., Schmutge, T., Roanhorse, A. and Jenkins, V. 2006. Using unmanned aerial vehicles for rangelands: Current applications and future potentials. *Environmental Practice*, 8:159-168.
- Schmale, D. G., Dingus, B. R., Reinholz, C. 2008. Development and application of an autonomous unmanned aerial vehicle for precise aerobiological sampling above agricultural fields. *Journal of Field Robotics*, 25, 133-147.
- Wu, J., Zhou, G. and Li, Q. 2006. Calibration of small and low-cost UAV video system for real-time planimetric mapping. *In Proceedings of the International Geoscience and Remote Sensing Symposium (IGARSS)*. July 31-Aug. 4. Denver, CO.

**Session 2:**  
**Weed-Crop discrimination**





## TOPIC n° 2.2

### Automatic mosaicking of very high spatial resolution UAV multispectral images for precision agriculture: Test of MICMAC freeware

Sylvain Labbé<sup>1</sup>, David Gómez-Candón<sup>2</sup>, Ghina El-Natour<sup>1</sup>, José Dorado<sup>3</sup>, César Fernández-Quintanilla<sup>3</sup>, Francisca López-Granados<sup>2</sup>, José M. Peña-Barragán<sup>2</sup>, Ana I. De Castro<sup>2</sup>, Jorge Torres-Sánchez<sup>2</sup>, Gilles Rabatel<sup>1</sup>.

<sup>1</sup>IRSTEA, Montpellier (France), (sylvain.labbe@teledetection.fr)

<sup>2</sup>Institute for Sustainable Agriculture, CSIC, Córdoba (Spain), (dgomez@ias.csic.es)

<sup>3</sup>Institute of Agricultural Sciences, Madrid (Spain), (cesar@ccma.csic.es)

**Keywords:** Image mosaicking, precision agriculture, UAV

---

#### Abstract:

For precision agriculture purposes, use of UAV could be helpful to create on demand centimeter resolution multispectral ortho-images of a plot. This high resolution imagery can then be used for instance in weed detection and treatment. However to be efficient, the computation chain between images acquired from UAV and ortho-rectified useful data should be fully automatic, fast and cost efficient. This paper evaluates the ability of “MICMAC” freeware to support such process. It focuses particularly on geometric precision aspects when using multiple sensors (visible and near infrared, NIR). Tests were conducted on an experimental plot in Spain using visible and NIR sensors. It concludes on good results when using only one visible RGB camera and the standard MICMAC processing chain. Independent processing with MICMAC of NIR images does not lead to enough accurate geometric precision. Further developments are suggested to tackle this issue.

---

#### 1. Introduction

Recent technological advances have made possible the site specific management of agricultural crops (López-Granados, 2011). The RHEA project (EU-7th Frame Program) is focused on the design, development, and testing of a new generation of automatic systems for precision agriculture and, in particular, for site specific weed management (SSWM). RHEA aims the application of precision agriculture strategies



by using a fleet of small, heterogeneous robots –ground and aerial– equipped with advanced sensors, enhanced end effectors and improved decision control algorithms. One of the main tools of the project is the weed detection using Unmanned Aerial Vehicle (UAV) remote imagery. However, UAV image series ortho-rectification and mosaic is a time consuming process. There have been a lot of research efforts on automatization of the geo-referenciation and mosaicking processes for UAV imagery (Xiang & Tian, 2011; Gómez-Candón *et al*, 2012).

SIFT (Scale Invariant Feature Transform) is an algorithm developed to extract distinctive invariant features from images. A large number of features can be extracted from typical images with efficient algorithms (Lowe, 2004). Since it was developed, many efforts have been done on the SIFT application over UAV image series (Xing & Huang, 2010; Barazzetti *et al*, 2010). MICMAC (Pierrot-Deseilligny & Paparoditis, 2006) is an open-source software (<http://www.micmac.ign.fr>) specialized in image matching, based on command line tools. MICMAC is composed by four main steps. First, the computation of tie points using PASTIS tool based on SIFT algorithm. The second step is to use APERO (Pierrot-Deseilligny & Cléry, 2011) tool and the calculated tie points for the calibration and the orientation of images. The next step is to use MICMAC tool for the automatic matching, computation of a digital elevation model (DEM) and ortho-rectification of images, based on multi-correlation techniques and multi-resolution approach, and finally mosaic ortho-rectified images for a global geo-referenced image through PORTO tool. MICMAC needs in input only ground control points and overlapping images and can produce automatically in a small amount of time a mosaic of the plot. This near “real time” aspect is important so that the weed detection and treatment could start a short time after the flight.

The aim of this study was to compute the accuracy of the ortho-mosaics done by MICMAC free software and to assess their capability to be used for SSWM. The specific objectives are to calculate their accuracy depending on the selected method of orientation estimation. And the second specific objective is to test the accuracy between visible and NIR mosaics, in order to see if they are able to be overlapped.

## **2. Material and methods**

The studies were conducted in the province of Madrid (Spain). One



weed infested maize plot, of about 1 ha was selected, named Arganda. The coordinates (UTM System, 30-N) of the centre of the plot were  $X = 458757$  m,  $Y = 4462724$  m. The ground is flat (average slope  $<1\%$ ). At the study plot, the images were taken from a Mikrokopter Hexakopter UAV (Fig. 1) equipped with two twin Sigma DP2x cameras, one visible (Red-R, Green-R and Blue-B bands) and the other was modified to register into the NIR band (Rabatel *et al*, 2011). The DP2x camera is built on a foveon sensor of  $2640 \times 1760$  pixels  $\times$  3 layers. This multilayer sensor ensures that raw DN given in each band (R, G and B) is issued from the same pixel (and not interpolated between pixels like with bayer matrix sensors). This is important to ensure that multispectral indices are coherent. The matter is then to overlay the NIR to the visible bands with a geometric accuracy comparable to the image pixel size.



Fig. 1. UAV used, left and study area, right.

Over the whole field, artificial GCPs (Ground Control Points, formed by  $0.40\text{m}$  squared targets) were placed using a grid of about  $12.5 \times 12.5\text{m}$ . GCPs were geo-referenced using a LEICA 1200 RTK DGPS. Up to 20 GCPs were used for the ortho-rectification and 95 GCPs for the validation process to estimate the accuracy of the ortho-rectification and mosaicking procedure. Two series of 100 images at  $30\text{m}$  flying altitude (corresponding to a pixel size of  $0.019\text{m}$  on the ground), 100 per visible and 100 per NIR were taken using a GPS based trigger included on the UAV. A support compensates the roll and nick movements of the UAV to ensure that each image is taken with a nearly nadiral view. The overlap between images is at least  $60\%$  on the same line and  $30\%$  between lines so that a DEM can be computed (each point of the plot is seen at least on two images).

Images were processed in order to ortho-rectify and mosaic them using



MICMAC software to create a unique ortho-mosaic of the entire plot. Three ortho-mosaics were generated, the first method is by using the visible-RGB series computing directly the orientation of all images, without having a good initial estimation of the intrinsic calibration, this is called Visible-direct. The other two mosaics, one visible-RGB and one on the NIR band, were created in two steps, initially by computing the orientation on a set of ten images, to compute a first estimation of the intrinsic calibration of the camera, and finally, the computed calibration is used as initial value to re-compute the orientation for all of the images (called Visible-re and Near-Infrared-re respectively). Once the ortho-mosaics were generated, the root mean square error (RMSE) of every validation GCP and the mean RMSE were calculated in order to assess the accuracy of each ortho-mosaic. With the purpose of compare error differences inside each image, a RMSE maps were computed by using the error of every single geo-referenced validation GCP. Furthermore, the overlapping error between Visible-re and Near-Infrared-re ortho-mosaics was calculated by measuring the Euclidean distance between common points.

### 3. Results and discussion

Results shown that there is an improvement in accuracy when doing a previous orientation of the images 0.016m and 0.400m for the Visible-re and the Visible-direct respectively (Table 1). Best results are shown for the Visible-re, and the RMSE (0.016m) was close to the pixel size of the image (0.019m). Regarding to comparison between the Visible-re and Near-Infrared-re mosaics, geo-referenciation error seems to be higher for the Near-Infrared-re (0.035m) than the Visible-re (0.016m).

The ortho-mosaics generated by using MICMAC are shown on Figure 2. Results shown a noticeable good image matching in the center, while distortion problems exist at the borders of the mosaic in visible and NIR, also there are some color differences in each of the two mosaics which can be solved by color rectification. These geometric errors could be explained by the DEMs used. The proposed automated procedure computes two DEM, one for each series of image. The visible images with 3 bands and a high level of texture leads to a more precise DEM than the one computed with the monochromatic and less textured NIR images. Also all these DEM are less precise on the external part of the mosaic leading to observed distortion. Regarding to RMSE distribution, it does not follow any recognizable pattern. Apparently, RMSE has to be lesser in the center area where the image matching is better, but results do

not support it.

Table 1. RMSE of Arganda plot using Visible and NIR cameras and different methods of ortho-rectification

	<i>Visible-re</i>	<i>Visible-direct</i>	<i>Near-Infrared-re</i>
	RMSE (m)	RMSE (m)	RMSE (m)
Overall	0.016	0.400	0.035
( $\pm$ s.d.)	0.008	0.247	0.048

The assessed overlapping accuracy was 0.033m which is more than one pixel. This accuracy is not enough to compute vegetation indices like NDVI with pixel size accuracy (required accuracy should be enough to detect weed leaves that have about 2cm large).

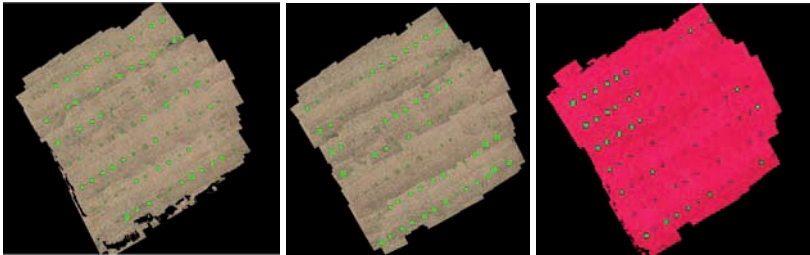

Fig. 2: MICMAC Ortho-mosaics, Visible-re (left), Visible-direct (middle) and Near-Infrared-re (right). Green circles show the RMSE of each validation point, the bigger the circle the higher the error.

### 3. Conclusions

Use of MICMAC software is able to make ortho-mosaics on agricultural areas using a set of visible or a set of NIR images. When using MICMAC software it is advisable to use an iterative process with a first approximation of the orientation of the images. The computed RMSE for the Visible-re and Near-Infrared-re was under crop row spacing of maize (0.40m), which is enough to crop line detection.

These overlapping errors are mainly due to the automatic computed DEM accuracy. To overcome this problem several ways could be explored: First, the use of an external known DEM of the plot. This approach is convenient if the crop is not high so that DEM and DTM can be considered as equivalent. Secondly, the use of the DEM computed with the visible images to ortho-rectify the NIR images. This approach impose that all bands are acquired simultaneously so that all the processes could be automatically chained in a short amount of time. Finally, to perform an initial precise matching between visible and NIR



images, leading to 4 bands images, before entering the other photogrammetric steps needed for ortho-rectification. This approach is classic on many multi sensor devices, its weakness is to increase the number of image transformations

The RHEA team should explore these approaches with different crops (variety, height, etc.) to improve the automatic processing of the acquired multispectral multi sensors images using MICMAC freeware. Another issue to tackle in the project is the automatic detection of ground control points in the image (using known referenced targets) so that the full process from UAV image acquisition to treatment device on the field would be fully automatic.

## Acknowledgements

*This research was partly financed by RHEA Project (ref.: NMP-CP-IP 245986-2, EU-7th Frame Program).*

## References

- Barazzetti, L., Remondino, F., Scaioni, M. and Brumana, R., 2010. Fully automatic UAV image-based sensor orientation. *International Archives of Photogrammetry, Remote Sensing and Spatial Information Sciences*, 38(1). 6 pages (on CD-ROM).
- Berni, J., Zarco-Tejada, P., Suarez, L., Gonzalez-Dugo, V., Fereres, E. 2008. Remote Sensing of vegetation from UAV platforms using lightweight multispectral and thermal imaging sensors. *International Archives of the Photogrammetry, Remote Sensing and Spatial Information Sciences*, vol. XXXVII.
- Du, Q., Raksuntorn, N., Orduyilmaz, A., Bruce, L.M. 2008. Automatic Registration and Mosaicking for Airborne Multispectral Image Sequences. *Photogrammetric Engineering & Remote Sensing* Vol. 74, No. 2, pp. 169–181.
- Gómez-Candón, D., López-Granados, F., Caballero-Novella, J.J., Gómez-Casero, M.T., Jurado-Expósito, M., García-Torres, L. 2012. Geo-referencing remote images for precision agriculture using artificial terrestrial targets. *Precision Agriculture*, 12, Num: 6, pp. 876- 891.
- López-Granados, F., 2011. Weed detection for site-specific weed management: mapping and real-time approaches. *Weed Research*, 51, 1-11.
- Lowe D. G. 2004. "Distinctive Image Features from Scale-Invariant Keypoints". *International Journal of Computer vision*, vol. 60, No. 2, pp. 91-110.
- Pierrot-Deseilligny, M., Cléry, I. 2011. APERO, an open source bundle adjustment—“Software for automatic calibration and orientation of a set of images.” In F. Remondino & S. El-Hakim (Eds.), *Proceedings of the ISPRS commission V symposium on image engineering and vision metrology*, March 2–4, 2011. Trento, Italy.
- Pierrot-Deseilligny, M., Paparoditis, N. 2006. A multiresolution and optimization-based image matching approach: An application to surface reconstruction from SPOT5-HRS stereo imagery. In *IAPRS vol. XXXVI-1/W41 in ISPRS Workshop on Topographic Mapping From Space (With Special Emphasis on Small Satellites)*, Ankara, Turquie, 02-2006.
- Rabatel, G., Gorretta, N., Labbé, S. 2011. Getting NDVI Spectral Bands from a Single Standard RGB Digital Camera: A Methodological Approach. *Lecture Notes in Computer Science*, 2011, Volume 7023/2011, pp 333-342.
- Xiang, H., Tian, L. 2011. Method for automatic georeferencing aerial remote sensing (rs) images from an unmanned aerial vehicle (uav) platform. *Biosystems Engineering*, 108(2), pp 104–113.
- Xing, C., Huang, J. 2010. An improved Mosaic Method Based on SIFT Algorithm for UAV Sequence Images. 2010 International Conference on Computer Design and Applications (ICCCA 2010), volume 1, pp. 414–417.



**TOPIC n° 1.2**

**Evaluation of features for context based crop classification**

**Henrik Skov Midtiby<sup>1</sup>, Rasmus Nyholm Jørgensen<sup>1</sup>**

<sup>1</sup>*Institute of Chemical Engineering, Biotechnology and Environmental Technology,  
University of Southern Denmark, Campusvej 55, 5230 Odense M, Denmark (e-mail:  
hemi@kbm.sdu.dk)*

**Keywords:** visual crop detection, in row hoeing, non-chemical weed control, context information, row structure

---

**Abstract:** Weed control in the in-row area of row crops, requires knowledge about the location of individual plants. In-row weeding is used for weed control in transplanted crops like lettuce where plant size can be used to discriminate between crop and weed plants. Some crop plants are placed in a regular pattern, this pattern and whether a specific plant is a part of this pattern can be used to discriminate between crop and weed plants. The idea which is investigated in this paper is that a row score for each observed plant is calculated based on the relative position of neighbor plants. Three different row scores are described and tested for recognizing a repeated row structure. The three scores all give a measure of how well the current plant follows the expected row structure by investigating the expected locations of neighbor crop plants. The testing is conducted in a simulated environment where random fields with a certain row structure are constructed and the suggested measures are evaluated using the constructed artificial fields. The suggested measures were used to recognize crop plants based on their relative position to other plants in the field. An estimate of the performance of the best achieving context based classifier is determined based on the weed pressure and the crop position uncertainty.



## 1. Introduction

Machine vision systems for discrimination between crop and weed plants are often based on plant shape features (Weiss, 2007). In row crops with a well-defined structure in the row, e.g. fixed distance between neighboring crop plants, the row structure can be exploited and give information about where crop plant and weed plants are located. One approach is to add a number to each observed plant which describes how good that plant fits into the known row structure based on the position of nearby plants. In this paper different row scores are evaluated in a simulated environment.

This approach based on row scores for crop localization is suitable for machine vision systems like the one used on the Robovator ([www.visionweeding.com](http://www.visionweeding.com)). The Robovator has one camera mounted above each row. Crop plants are recognized based on their size. This is a commercial system used by organic farmers for lettuce production.

A machine vision system that should use the suggested context features must be able to determine the location of individual plants. If there is no overlap between individual plants (both crops and weeds), the center of mass of the located vegetation regions can be used as plant positions. When plants overlap, which they tend to do at a high weed pressure the center of mass approach is useless and a different approach is needed, e.g. plant locations can be determined by locating individual leaves (Midtiby, 2012a).

Recognizing plants based on the row structure and the observed plant locations requires a recognizable crop plant pattern. Crop plants seeded with an inter plant distance above 10 cm and with a fixed distance between neighboring crop plants can be used. Sugar beets, chicory and maize are all examples of crops that can be cultivated with a clear row structure.

## 2. Materials and methods

### 2.1 Definition of row structure

The basic property of a row structure that is used in this paper is the following. Given the position of one crop plant the position of the next crop plant can be predicted. An example of such a row structure is shown in figure 1. The characteristic part of the row structure is the distance between neighbor crop plants. The quality of the row structure is partly determined by the seeder and its ability to place seeds evenly spaced along the row.

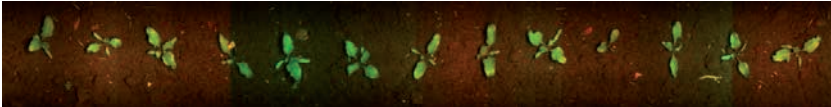

Fig. 1: Example of row structure in sugar beets.

### 2.2 Simulated field environment

In the simulated field environment the location of crop and weed plants can be sampled from random distributions which describe the field conditions. Each plant location is described with a two dimensional coordinate. Weed plants are placed uniformly within the simulated field and crop plants are placed along a straight line with a fixed distance between neighboring crop plants.

The expected distance between neighbor crop plants is  $d$  and the uncertainty in the position in both the  $x$  and  $y$  direction is denoted. The number of weed plants is determined from the weed density which is the number of weed plants per square meter.

### 2.3 Offset from expected neighbor location

The offset score is based on the assumption that the plant under considerations is placed on a grid location and then the next  $N$





crop locations according to the grid is investigated. For each of these locations is the plant nearest the location found and the distance,  $D$ , between that plant and the grid location is determined. The found distance is converted to a score using the equation

$$D^P$$

where  $P$  is the power the distance is raised to. The scores for each of the grid locations are added together and the position score for the  $l^{\text{th}}$  plant can be expressed as

$$c_l = \sum_{n=1}^N \min_j \left( \left( \frac{x_l + k d - x_j}{\sigma} \right)^2 + \left( \frac{y_l - y_j}{\sigma} \right)^2 \right)^{P/2}$$

#### **2.4 Position score**

The position score is based on the same assumption as the offset score. The only difference is that the found distance is converted to a score using the following equation

$$\exp\left(\frac{-1}{2S} D^P\right)$$

where  $S$  is a weighting parameter.

The scores for each of the grid locations are summed and the position score for the  $l^{\text{th}}$  plant can be expressed as

$$c_l = \sum_{n=1}^N \max_j \exp \left[ \frac{-1}{2S} \left( \left( \frac{x_l + k d - x_j}{\sigma} \right)^2 + \left( \frac{y_l - y_j}{\sigma} \right)^2 \right)^{P/2} \right]$$

#### **2.5 Bayes score**

The Bayes score is an attempt at improving the position score. The main issue with the position score is seen when the crop plant under investigation is far away from the expected crop location. In this case will all the investigated neighbors seem to

be away from their expected locations and this will result in a relative low position score of the examined plant. The Bayes score is defined as the maximum position score that is based on the current plant and its  $N$  neighbors where the origin of the pattern can be placed without constraints. A similar measure was introduced in (Åstrand. 2005).

## 2.6 Overlap estimation

After a row membership score has been calculated for each plant, the quality of the row membership score can be quantified by looking at the overlap between scores from crop and weed plants respectively. The estimated density plots of crop and weed plants are shown in figure 2.

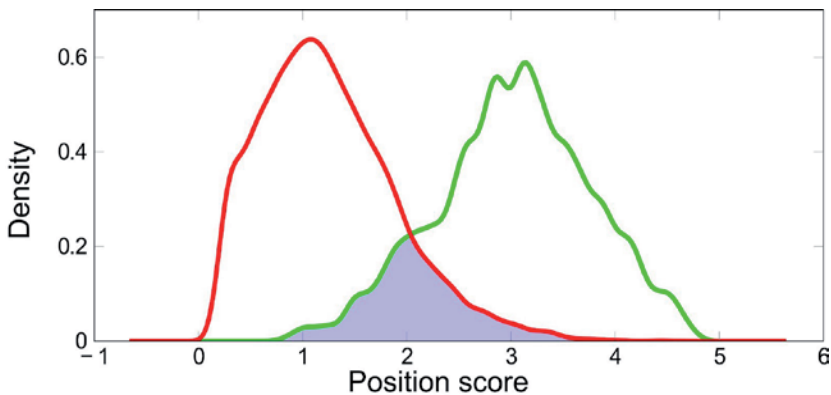

Fig. 2: Row membership scores of crop and weed plant populations shown in green and red respectively. The shaded area is the overlap between the two distributions. A good row membership score has a low overlap.

A method that only uses context information to recognize crop plants has its performance limited by the weed density,  $\rho$ , and the rigidity of the crop plant pattern (measured by the crop plant position uncertainty  $\sigma$ ). These measures can be combined to the normalized weed pressure,  $\lambda$ , which is defined as

$$\lambda = 2 \pi \rho \sigma^2$$



If crop plants are identified as the plants closest to the known seeding location, the crop recognition rate is given by

$$\frac{1}{1+\lambda}$$

This is derived in (Midtiby et al., 2012b).

### 3. Results and conclusions

Artificial fields with 1000 crop sowing locations and an upgrowth ratio of 0.7 were used for the following experiments. The three row membership scores have been compared under different weed pressures and crop location uncertainties. The offset score had a higher overlap than both the position score and the Bayes scores. When the number of investigated neighbors is low position scores and Bayes scores have similar overlaps, when the number of neighbors is increased the Bayes score is doing better than position scores.

Table 1. Context feature overlaps for the three different row scores. 10 repeated experiments with 1000 plants and investigating 10 neighbor locations are the basis of these numbers.

Row score	Overlap percentage	
	Average	Standard deviation
Offset	21.95 %	1.20 %
Position scores	20.43 %	1.09 %
Bayes scores	18.21 %	0.95 %

### References

- Midtiby, H. S., Giselsson, T. M., & Jørgensen, R. N. (2012a). *Estimating the plant stem emerging points (PSEPs) of sugar beets at early growth stages*. Biosystems Engineering, 111(1), 83-90. doi:10.1016/j.biosystemseng.2011.10.011
- Midtiby, H. S., Åstrand, B., Jørgensen, O., & Jørgensen, R. N. (2012b). *Upper limit for context based crop classification*. Submitted to Biosystems Engineering.
- Weis, M., & Gerhards, R. (2007). *Feature extraction for the identification of weed species in digital images for the purpose of site-specific weed control*. Precision Agriculture '07 (pp. 537-544).
- Åstrand, B. (2005). *Vision based perception for Mechatronic weed control*. Chalmers University of Technology.
- Åstrand, B., & Baerveldt, A. J. (2004). *Plant recognition and localization using context information*. Proc. of the IEEE Conference Mechatronics and Robotics (pp. 13-15).



TOPIC n° 2.2

**Real-time weed/crop discrimination through fast direct  
image registration**

**Xavier P. Burgos-Artizzu<sup>1</sup>, Piotr Dollár<sup>2</sup>, Angela Ribeiro<sup>3</sup>,  
Pietro Perona<sup>1</sup>**

<sup>1</sup>*Computation and Neural Systems, MC 136-93. California Institute of Technology,  
Pasadena, CA, USA ([xpburgos@caltech.edu](mailto:xpburgos@caltech.edu), [perona@caltech.edu](mailto:perona@caltech.edu))*

<sup>2</sup>*Microsoft Research, Redmond, WA, USA ([pdollar@microsoft.com](mailto:pdollar@microsoft.com))*

<sup>3</sup>*Center for Automation and Robotics (CAR). UPM-CSIC. Arganda del Rey, Madrid,  
Spain. ([angela.ribeiro@csic.es](mailto:angela.ribeiro@csic.es))*

**Keywords:** Weed/crop discrimination, Crop row detection, Real-time image processing, Video stabilization, Automatic vehicle guidance

---

**Abstract:** This paper presents a computer vision system that is able to discriminate between weed patches and crop rows in real-time, from videos taken directly from a tractor moving through the field. Weed/crop discrimination is highly simplified thanks to video stabilization. We present a simple but effective variant of the inverse compositional algorithm for image alignment, and show that on our videos, our optimized version of the algorithm performs just as well as key-point matching methods, while being up to 2x faster. Once the video stabilized, crop rows remain almost constant through short periods of time, and be detected by a simple image processing. We tested our approach on several videos, taken in different maize fields on different dates, and presenting a variety of weed/crop conditions. Our final approach achieves a mean recognition of 84% on weeds and 91% on crop pixels, improving on our previous work 9% and 29% respectively.

---

## 1. Introduction

Real-time weed/crop discrimination is a desired outcome in many applications of precision agriculture. This paper presents a computer vision system that is able to discriminate between



weed patches and crop rows in real-time, through prior video stabilization.

We present a simple but effective variant of the inverse compositional algorithm for image alignment introduced in (Baker and Matthews, 2001, 2004). This direct method has fallen out of use, in favor of interest point matching methods, such as the widely used Scale-Invariant-Feature-Transform, SIFT, (Lowe 1999). Although it is true that SIFT outperforms direct registration methods on standard, rich images, it does not so on less structured images, and especially in continuous video. Homogeneous images such as those of a crop field make the correct matching of interest points difficult. Also, in a video running at 25 frames per second, the change across frames is small, and therefore direct registration methods work well. We show that on our videos, our optimized version of the inverse compositional algorithm performs just as well as SIFT, while being up to 2x faster, running at 40 fps in a single core CPU.

Once stabilized, crop rows remain almost constant through short periods of time, and weeds can therefore be discriminated by their position between crop rows and their movement across frames by a simple image processing.

## 2. Materials and methods

Section 2.1 introduces the proposed variant to the Inverse Compositional Algorithm for image alignment, while Section 2.2 outlines the image processing for weed/crop discrimination.

### 2.1 Inverse Compositional Algorithm

The first step of the proposed method is to stabilize the video. Each frame is registered to its next using an optimized version of the inverse compositional algorithm for image alignment, introduced in (Baker and Matthews, 2001).

The input to the alignment algorithm is a reference image  $I_0$  and a transformed version of  $I_0$ , denoted by  $I$ . The goal is to recover a transform  $T \circ I = I_0$ , where  $T \circ I$  denotes application of the transform  $T$  to the image  $I$ . We assume that the transform  $T$  comes from a known set of continuous transforms with  $k$  degrees of freedom. We also use  $(T_0 \circ T_1)$  to denote an operator on two transforms.

Let  $T^\delta$  denote  $\delta$  applications of  $T$ . The key behind direct approaches to estimating a transform  $T$  is the assumption that for small  $\delta$ , the following holds:

$$T^\delta \circ I \approx I + dI \cdot \delta \quad (1)$$

Here,  $dI$  is the first order approximation of  $T^\delta \circ I$ ,  $dI = (T^\delta \circ I) - I$ , see Fig. 1. This linearity assumption is directly related to the smoothness of the manifold, which in turn is related to the smoothness of the image itself. Smoothing images prior to applying the method makes (1) more accurate. However, smoothing an image results in a loss of information, so the amount of smoothing has to be chosen carefully.

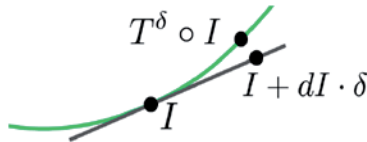

Fig. 1. Direct methods for image alignment assume that applying a small amount  $\delta$  of a transform  $T$  can be represented reasonably well by a first (or second) order approximation.  $\delta$  can be fractional.

Let  $T_1 \cdots T_k$  represent a set of  $k$  basis transforms, such that any transform can be written as  $T = T_1^{\delta_1} \circ T_2^{\delta_2} \circ \cdots \circ T_k^{\delta_k}$ . Applying equation (1) and dropping higher order terms, we get:

$$T \circ I \approx I + \nabla I \delta \quad (2)$$

where  $\nabla I$  is a  $n \times k$  matrix with each column  $k$  set to  $(T_k \circ I) - I$ . Given (2) and combining it with (1) we finally get:

$$I + \nabla I \delta \approx I_0 \quad (3)$$

See Fig. 2 for a visualization of equation (3). We can solve for  $\delta$  using least squares. To ensure the estimation is well conditioned we perform Tikhonov regularization, encouraging small  $\|\delta\|_2^2$ :

$$\delta = (\nabla I^T \nabla I + \lambda E_k)^{-1} \nabla I^T (I_0 - I) \quad (4)$$

Here  $E_k$  is the  $k \times k$  identity matrix and  $\lambda$  is a small constant set to  $10^{-6}$  in all reported experiments. Finally, given  $\delta$ , we can compute  $T = T_1^{\delta_1} \circ T_2^{\delta_2} \circ \cdots \circ T_k^{\delta_k}$ .

The procedure described above can be improved further by warping  $I$  according to the recovered transform  $T$  to yield

$I' = T \circ I$ , then solving with  $I'$  in place of  $I$ . This gives a new transform such that  $T' \circ I' = T' \circ T \circ I \approx I_0$ .

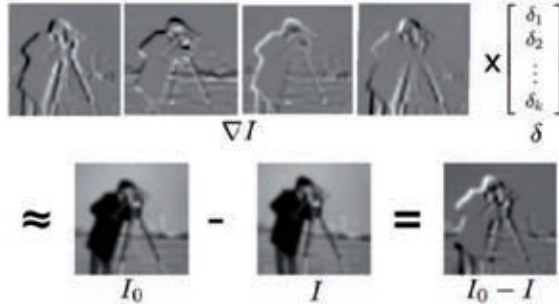

Fig. 2. A visual demonstration of equation (3). The derivative images  $\nabla I$ , combined using  $\delta$ , give rise to the difference  $I_0 - I$ . Given  $\nabla I$ ,  $I_0$  and  $I$ , least squares can be used to compute  $\delta$ .

The recovered transform after two steps is the *composition*  $T' \circ T$  and this procedure can be iterated until convergence (in practice only a few iterations are necessary). Note that in each iteration we must recompute  $\nabla I$ , which can be fairly costly. To avoid this computation, we can reverse the role of  $I_0$  and  $I$ , solving for a transformation  $T_0 \circ I_0 = I$ , and then applying the *inverse* transform  $T_0^{-1}$  to  $I$  at each iteration. The resulting approach is identical except  $\nabla I_0$  needs to be computed only once. As a result, the above algorithm is quite fast and can be implemented in about a dozen lines of code.

## 2.2 Image processing for weed/crop discrimination

The homographies computed using the Inverse Compositional Algorithm provide information on the displacement that occurred between two frames, and can therefore be used to align frames on top of each other. By doing this, all jumps in the image coming from tractor jolting or sudden lateral displacements are smoothed. Since the tractor travels parallel to the crop rows, the result is that in a stabilized video crop rows position is more stable, see top row of Fig. 3. Therefore, after vegetation is segmented from images (using the same approach as in Burgos-Artizzu et. al., 2011), crop rows can be detected with a simple AND operation over time, leaving weeds as the remaining vegetation pixels (after cleaning the image).



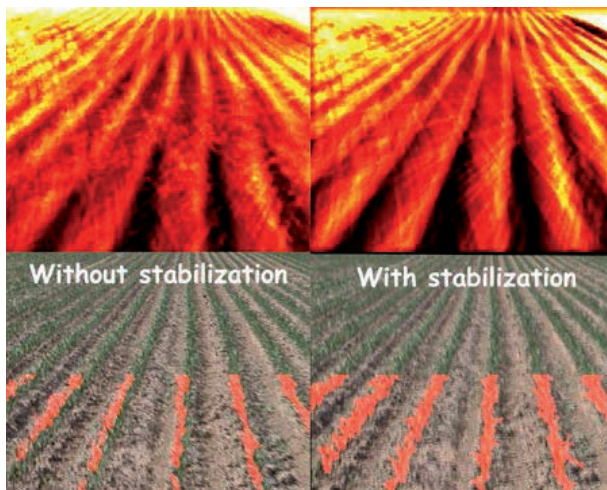

Fig. 3. Crop row detection comparison with video stabilization vs. no stabilization on movement video sequence. Top row: accumulated image over the first 3 seconds of a video. Bottom row: result of AND operation between frame  $t$  and frames  $[t - 1 \dots t - 9]$ .

### 3. Results and conclusions

Fig. 4 shows alignment results on frames from movement sequence, comparing the Inverse Compositional Algorithm (Homog) and a SIFT based image alignment. Homog is twice as fast, while performing similarly. Both methods can be applied at full image resolution or at smaller scales, for a trade-off between precision and speed. We use Homog at 1/4 resolution, which shows an alignment error only 4% superior to that of full resolution, while running 13x faster (40fps).

Table 1 shows weed/crop detection results on the same video sequences used in (Burgos-Artizzu et. al. 2011). The new method outperforms previous work in every video sequence, reaching an average 84% correct weed detection and 91% on crop, a 9% and 29% improvement respectively over (Burgos-Artizzu et. al. 2011). The method performs in real-time, at approximately 30 frames per second, on a single core CPU. The method robustness to tractor jolting and terrain irregularities suggests its future possible use for automatic guidance of agricultural vehicles through crop row detection.

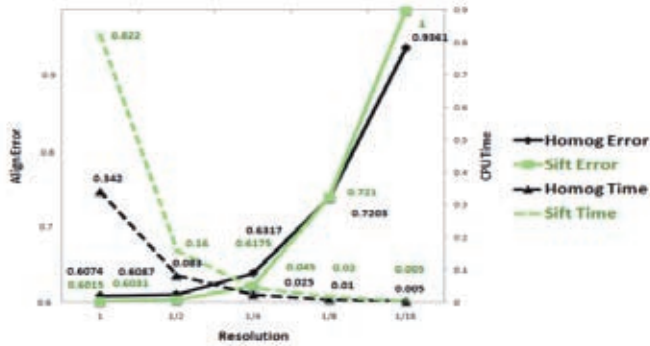

Fig. 4. Error and CPU Time comparison between SIFT and Inverse Compositional Algorithm (Homog) methods on 1500 576x720 frames from 6 different videos. Error is computed as the sum of squared differences between aligned and target image. Both algorithms are run at 4 different image resolutions, to find a trade-off between speed and precision.

Table. 1. Main weed/crop discrimination results on video sequences from (Burgos-Artizzu et. al. 2011)

	Fair2		Sowing Err		Patches		Movement		Average	
	Weed	Crop	Weed	Crop	Weed	Crop	Weed	Crop	Weed	Crop
(Burgos-Artizzu et al. 2011)	93%	83%	64%	65%	65%	70%	74%	36%	75%	62%
<b>Proposed approach</b>	86%	93%	64%	88%	89%	86%	96%	98%	84%	91%
Difference	-7%	+10%	0%	+23%	+24%	+16%	+22%	+62%	+9%	+29%

## Acknowledgements

First author holds a postdoctoral scholarship from the Spanish Ministry of Education and Science (MEC), Programa Nacional de Movilidad de Recursos Humanos del Plan Nacional de I-D+i 2008-2011. The Spanish Ministry of Education and Science (MEC) and the European Union have provided full and continuing support for this research work through projects Plan Nacional AGL2011-30442-C02-02 (GroW) and UE-CP-IP245986-2(RHEA).

## References

- S. Baker and I. Matthews (2001). *Equivalence and efficiency of image alignment algorithms*. Proceedings of the International Conference in Computer Vision and Pattern Recognition.
- S. Baker and I. Matthews (2004). *Lucas-kanade 20 years on: A unifying framework*. International Journal of Computer Vision, 56(3):221-255.
- X. P. Burgos-Artizzu, A. Ribeiro, M. Guijarro, and G. Pajares (2011). *Real-time image processing for crop/weed discrimination in maize fields*. Computers and Electronics in Agriculture, 75(2):337-346.
- D.G. Lowe (1999). *Object recognition from local scale-invariant features*. Proceedings of the International Conference on Computer Vision.



TOPIC n° 2.2

Ultrasonic measurements for weed detection in cereal crops

Dionisio Andújar<sup>1</sup>, Martin Weis<sup>1</sup>, Roland Gerhards<sup>1</sup>

<sup>1</sup> *Department of Weed Science, University of Hohenheim, Otto-Sander-Straße 5,  
70599 Stuttgart, Germany (e-mail: Andujar@uni-hohenheim.de)*

**Keywords:** Ultrasonic distance sensor, weed detection, biomass estimation, image processing

---

**Abstract** An automation of site-specific weed management requires sensing of the actual weed infestation levels in agricultural fields to adapt the management accordingly. In this paper, a sensor based weed detection method is presented and its applicability to cereal crops is evaluated. The sensing unit consists of an ultrasonic distance sensor for the determination of plant heights. It was hypothesised that the weed infested zones have a higher amount of biomass than non-infested areas and that this can be determined by the plant height measurements. Ultrasonic distance measurements were taken in a winter wheat field infested by grass weeds and broad-leaved weeds. A total of 120 samples of different weed densities and compositions were assessed at two different dates. The sensor was pointed directly to the ground for height determination. In the following, weeds were counted and then removed from the sample locations, before a second sensor reading was taken. Differences between weed infested and weed-free measurements were determined. Images were taken simultaneously and the coverage of weeds and crop were determined using image-processing methods. Dry-matter of the weeds and crop was assessed and evaluated together with the sensor measurements. RGB images were taken prior and after weed removal to determine the coverage percentages of weeds and crop per sampling point. The images



were transformed and thresholded to separate plants and background. The relationship between ultrasonic readings and the actual values of the crop and weed coverage was assessed using regression analysis. Results revealed a height difference between infested and non-infested sample locations. Density and biomass of weeds present in the sample influenced the ultrasonic readings.

---

## 1. Introduction

Automation of site-specific weed management has inspired many research developments. However, the sensing devices for weed detection are still a limiting factor for practical applications (Christensen, 2009). Since most of studies have used machine vision techniques to detect and identify plant species based on their shape, colour and texture features (Burgos-Artizzu et al. 2009; Weis and Sökefeld 2010), not too many efforts have been put into the development of other sensing systems. The concerns still are the associated cost and the relatively complex computations. The lack of commercially available systems is a major problem. The use of optical sensors such as optoelectronic devices that can spray weed patches present in fallow sites and in various wide-row crops (Biller, 1998) has probed its possibilities. However, these sensors are not able to differentiate weeds from crops and the economic costs are still high. Previous works showed that plant height and biomass are important parameters that can be estimated using ultrasonic sensors (Reusch, 2009). Swain et al. (2009) used these sensors to discriminate weedy and bare spots in wild blueberry fields. Andújar et al. (2011) showed the potential of this system for weed discrimination of broad leaves and grasses with a great correlation between weed biomass and ultrasonic readings in maize crops. This study extends the previous work to cereal crops. It was hypothesised that the weed infested zones have a higher amount of biomass than non-infested areas and that this can be determined by the plant height measurements.

## 2. Materials and methods

### 2.1 System description

All readings were taken with a Pepperl+Fuchs UC2000-30GM-IUR2-V15 ultrasonic sensor, pointing straight downward to the ground. The ultrasonic sensor measured the distance to the crop and weed mixture by counting the lapse time between emission and reception of the emitted signal. The transducer ultrasound frequency is approximately 180 kHz with a sensor resolution of 0.48 mm when working in full evaluation range and divergence angle was established for leading to a 0.20 m diameter footprint when placed at a height of 0.80 m. The sensing range, according to manufacturer, was 80–2000 mm and the accuracy 0.1%. A calibration curve (1) with an  $R^2$  of 0.99 was established for height determination, in order to convert the relation between the received output signal  $v$  (ranged from 0 to 10 V) and distance  $d$  (m).

$$d(\text{m}) = 7.0275 v + 29.658 \quad (1)$$

A software was developed for ROS (Robot Operating System, Quigley, et al. 2009) to acquire the sensor output, converting the voltage into a distance. The height of the crop and weeds was estimated by subtracting the actual estimated distance from the reference distance (0.80 m).

### 2.2 Experimental site and measurement procedure

Field experiments were conducted at Ihinger Hof Research Station (Rennigen, Germany). Winter wheat was sown with 17 cm of row spacing. Readings were taken at two dates, the first assessment was carried out on 26 and 27 March and the second on 9 April in order to cover different weed and crop stages. The field was mainly infested with *Echinochloa crus-galli*, *Lamium purpureum*, *Galium aparine*, and *Veronica persica*. A pre-emergence herbicide treatment was applied prior to weed assessment. A total of 80 sampling points were recorded on the first date and 40 on the second date. Points were chosen to reflect different weed compositions of grasses, broad leaved and mixtures of both. These locations were measured by pointing the sensor at the centre of the sampled area for height determination.



Immediately after taking ultrasonic readings, weed and crop density was counted and actual height of the weed groups (grasses and broad leaves) was determined using a metric rule. Also, an RGB (red, green, blue) image was taken for weed and crop coverage determination. Then, all weed present in a 0.20m diameter circle, coinciding with the sensor footprint, were hand-harvested, not disturbing the ground, and taken to the laboratory for biomass determination (dry weight basis). Finally a second RGB image was taken for the evaluation of the crop coverage.

The coverage was determined before and after removal of weeds. It was assessed with an image processing approach. Images were taken with standard RGB (red, green, blue) cameras in the field. The area of measurement, defined using a circular frame, was visible in the images. This area of interest was defined in the alpha channel of the image, with a transparent background and opaque region of measurement. These regions were defined manually, then the image was fed into an automated image processing chain. The first step of the image processing was the calculation of the EGI (excess green index,  $EGI=2G-R-B$ ) which leads to a grey level image with bright green objects (plants) and dark other objects having a different color. Based on the EGI a threshold was defined that separated the objects pixel-wise into foreground (plants) and background, leading to a binary image. These steps are visualized in figure 1. From the binary image the number of foreground  $p_f$  and background pixels  $p_b$  were counted. Only pixels within the previously defined area of interest were taken into consideration (no transparency). The ratio  $C = p_f / (p_b + p_f)$  is the percentage of plant coverage.

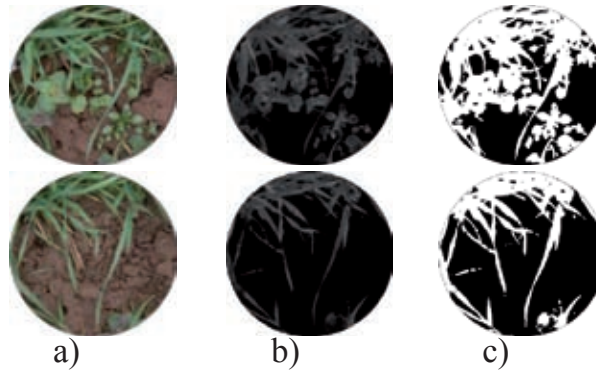

Figure 1. Process of image analysis before and after weed harvesting. a) RGB image, b) greenness image and c) thresholded image.

### 2.3 Statistical analysis

Multiple linear regression analysis was used to explore the relationship between experimental parameters that explained the differences in ultrasonic readings for the crop-weed composition in the measured combinations.

### 3. Results and conclusions

Good correlations were obtained between ultrasonic readings and the analysed variables. Correlations were significant with  $\alpha = 1\%$ . Ultrasonic readings were well correlated with weed coverage reaching an  $R^2=0.55$ . In the case of weed density and weed biomass these values were higher with a  $R^2$  of 0.63 and 0.65 respectively. The comparison between the data obtained with the ultrasonic device and those obtained from the ground truth indicated good relationships between the two sets of data, with an adjustment of the model of 0.325 (Table 1). The results showed the potential of this technique to assess weed density and coverage, being ultrasonic readings good predictors of these agronomic parameters. In contrast, at the second sampling date, results did not show significant values, which implies a short window of time for the use of this methodology. This fact was due to a further plant development of the crop which almost





completely covered the ground. Weeds shorter than the crop are missed in these cases.

Table 1. Multiple regression analysis between ultrasonic readings and measured coverage and biomass at first date.

	Coefficient	Standard error	P-value
Coverage	0.029	0.011	0.009
Biomass	0.07	0.033	0.038
$R^2=0.325$			

It can be concluded, that the presented methodology can determine a weed infestation as long as the wheat crop is not too developed. In a previous study in a maize crop (Andújar et al. 2011) interference was avoided, since the crop plant was not measured (inter-row). Nevertheless, the measurement principle can be combined with optical sensing devices without interference. These sensors are relatively cheap and easy to integrate into real-time applications. Further experiments have to be conducted before market-readiness can be achieved.

## Acknowledgements

*This research was funded by the Foundation “Alfonso Martín Escudero”.*

## References

- Andújar, D., A. Escola, J. Dorado and C. Fernández-Quintanilla (2011). Weed discrimination using ultrasonic sensors. *Weed Research*, 51,543-547.
- Biller, R.H (1998). Reduced input of herbicides by use of optoelectronic sensors. *Journal of Agricultural Engineering Research*, 71, 357–362.
- Burgos-Artizzu, X.P, A. Ribeiro,A. Tellaeche and G. Pajares (2009). Improving weed pressure assessment using digital images from an experience-based reasoning approach. *Computers and Electronics in Agriculture*, 65, 176–185.
- Christensen, S., H. Søgaard, P. Kudsk, M. Nørremark, I. Lund, E. Nadimi, and R. Jørgensen (2009). Site-specific weed control technologies. *Weed Research*, 49 (3), 233-241.
- Quigley, M., K. Conley, B. P. Gerkey, J. Faust, T. Foote, J. Leibs, R. Wheeler, and A. Y. Ng (2009). ROS: an open-source Robot Operating System. ICRA Workshop on Open Source Software.
- Reusch, S (2009). Use of ultrasonic transducers for on-line biomass estimation in winter wheat. Precision Agriculture\_09. (Eds E.J Van Henten, D. Goense & C Lockhorst), 169–175.
- Swain K.C, Q.U.Z. Zaman, A.W. Schumann and D.C. Percival (2009). Detecting weed and bare-spot in wild blueberry using ultrasonic sensor technology. Proceedings of ASABE Meeting, Paper No 096879.
- Weis, M. and M. Sökefeld (2010, August). Precision Crop Protection - the Challenge and Use of Heterogeneity (1 ed.), Volume 1, Chapter Detection and identification of weeds, pp. 119-134. Dordrecht/Heidelberg/London/New York: Springer Verlag.



**First RHEA International Conference on  
Robotics and associated High-technologies  
and Equipment for Agriculture**  
Hosted by the University of Pisa  
Pisa, Italy, September 19-20-21, 2012



## TOPIC n° 2.2

Weed mapping in cotton using proximal and remote sensing  
under GIS environment

A. Papadopoulos and D. Chachalis

*Benaki Phytopathological Institute, Weed Science Laboratory, 8 Stefanou Delta  
Street, 14561, Kifissia, Athens, Greece*

Keywords: site-specific weed management, cotton,  
groundbased sensors, remote sensing, GIS.

---

**Abstract:** Weed mapping using proximal and remote sensing was developed in a cotton field, as part of an EU LIFE+ project (Acronym: HydroSense). The objective of the present research is to spatially record and map weed density using multispectral groundbased sensors, analyzing high resolution satellite images and digitally processing RGB photographs. Field work was also preformed involving the recording of weed species and weed population at a network of 30 ground points across the field. A GIS database was constructed containing all spatial and descriptive data and further spatial and statistical analysis was performed. NDVI maps were created and overlaid from both ground and satellite sensors. Field raw data in conjunction with image analysis performed in the photographs taken *in situ*, via MATLAB software, drove to the calculation of weed coverage percentages across the study field. The preliminary results of the analysis show correlation between field data and the estimated weed density values derived from NDVI maps. Early construction of accurate and reliable weed maps which classify fields into various spatial zones of different weed pressure can lead to better weed management optimizing environmental and input costs.

---

## 1. Introduction



Weed management consists of a crucial and demanding agronomic process prior and during a cultivation period. Weed incidents are not homogenous across fields. In fact weed populations generally grow in patches; however producers tend to apply uniform rates of agrochemicals across their fields. This practice suggests unjustified use of pesticides and implies extra costs and environmental burdens. The key point in adapting and balancing inputs according to weed locations is the integrated monitoring of weed flora in terms of time and space. Various studies have been conducted for sensing weeds across a field using image analysis methods (Tellaeche et al., 2008, Gerhards and Oebel, 2006), remote sensing products and vegetation indices (López-Granados, 2011) and GIS methodologies (Kalivas et al., 2010). The objective of the present research is to spatially record and map weed density with the combination of three different methodological approaches.

## 2. Materials and methods

The study area is situated in the plain of Thessaly, Central Greece. The research field (Gyrtoni) is sown with cotton and its area is 1 hectare. The field prior to sowing was soil sampled in a dense network for basic soil analyses including organic matter percentage, soil acidity, electrical conductivity etc. According to soil organic matter content, the field was delineated into two management zones (zone a and b).

### *2.1 Proximal sensing data*

In June of 2011, the spaces between cotton rows were scanned with two multispectral sensors which were mounded on a tractor. The sensors were linked to a GPS capable of collecting differentially corrected signal with below 10 cm accuracy. Both sensors and the GPS were connected to a data logger in order to record georeferenced data. The height of the bar carrying the two sensors, the GPS antenna and the data logger was carefully adjusted to avoid conflicts with cotton canopy, which would have resulted in false measurements. The output of the sensors' readings were georeferenced reflectance measurements in red, near-infrared, red-edge bands and also spatial referenced values of the spectral vegetation indices red-edge NDVI and NDVI.

The sensors' readings were stored in a GIS database and assigned to point entities.

### *2.2 Field work and image data collection*

When cotton was at 7-8 mainstem nodes, the actual state of weed distribution in the field was monitored. The predominant weeds recorded, were broadleaves (*Datura stramonium*, *Solanum nigrum* and *Chenopodium album*) and were at vegetative growth stage. The weed monitoring held in 30 preselected ground points inside the borders of the pilot farm. Further, for each selected point, the working team used 9 wooden frames (0.5 x 0.5 m each). These frames were placed between four adjacent rows of cotton; delimiting the area of the recordings. All frames were photographed with a D300S Nikon camera, which was mounted on a tripod at 1.0 m distance from ground level. Via an algorithm built in MATLAB software (MathWorks) and based on proper thresholding the images, a percentage of weed coverage per image was extracted.

### *2.3 Remote sensing data*

For the purposes of the digital weed mapping, a set of WorldView-2 (WV-2) multispectral (2m pixel size) and panchromatic (0.5m pixel size) satellite data in 8<sup>th</sup> June 2011 was acquired. After pansharpening the WV-2 image (Brovey Transform was used resulting in spatial resolution of 0.5m), it was carefully georeferenced with the use of a network of 20 ground control points, which were selected in order to cover in a representative way the study area and be readily identifiable from the image. In accordance, the satellite image was atmospherically corrected. The area covered by the satellite image is of total 70 km<sup>2</sup>.

## **3. Results and discussion**

The raster surface of the predicted NDVI values across the pilot farm of Gyrtoni that was produced via kriging from groundbased sensors' readings is presented in Fig. 1. The values of NDVI range between 0.129 and 0.604, with the last class (0.456-0.604) indicating the presence of weeds.



According to zones' summary statistics the mean NDVI value in zone b is 0.363 while in a, is 0.256 (Table 1). Indeed, zone b retains increased values of NDVI with a maximum of 0.604. Weed presence in zone b can be attributed to soil characteristics like organic matter content and drainage conditions and/or to historical increased weed infestations which imply the existence of weed seeds in this part of the field.

Table 1. Summary statistics of the two management zones in Gyrtoni pilot farm produced by groundbased sensor readings.

Parameter	Zone a	Zone b
Area (m <sup>2</sup> )	2673.25	6665.25
Minimum NDVI	0.128	0.143
Maximum NDVI	0.461	0.604
Mean NDVI	0.256	0.363
SD	0.08	0.09

The results of the digital image analysis presented in Fig. 2, in the form of a weed cover map, verify that in zone b the patchiness of weed plants prevails that of zone's a. According to this map, the pilot farm is delineated into three classes of weed coverage with the first one (15.9-23.9%) denoting zone a. The other two zones (24.0-39.9%) are included in zone b. It should be noted that the weed cover map depicts the actual state of weed population across the field as it is based both on field work and on photograph shooting.

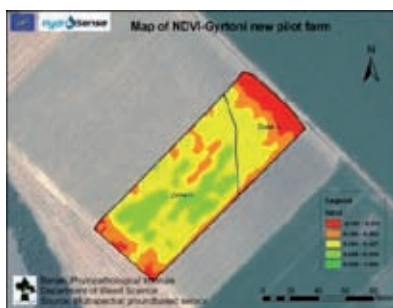

Fig. 1. Map of interpolated values of NDVI recorded by groundbased sensors.



Fig. 2. Map of interpolated values of weed cover (%) from image analysis.

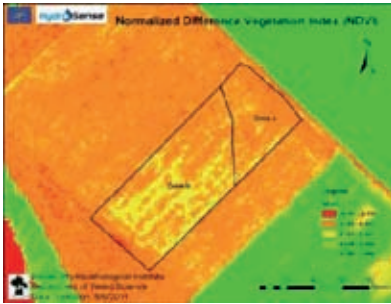

Fig. 3. Satellite NDVI map of Gyrtoni pilot farm.

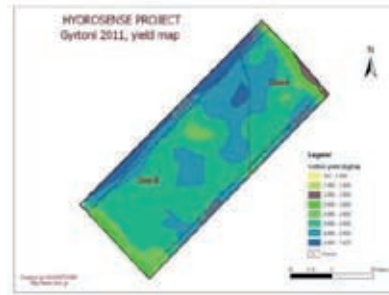

Fig. 4. Yield data of Gyrtoni pilot farm.

However, a denser sampling scheme could have produced more accurate results based on kriging geostatistical method, resembling the NDVI map in Fig. 1.

The distribution pattern of NDVI's values produced by groundbased sensors is comparable to the one produced by the satellite image (Fig. 3). According to Fig. 3, the mean value of NDVI in zone a, is 0.245 and in zone b is 0.272. The classification of NDVI as derived from the WV-2 image and as limited to the borders of the pilot farm lacks the last class (0.595-1.000), which is actually met in the nearby alfalfa field. In fact, Fig. 1 is the product of interpolated NDVI point values in opposition to Fig. 3 which is the direct calculation of a fraction of two raster layers (red and near infrared bands). In consequence, the comparison of these two maps cannot be strictly statistical, however in both cases one can easily conclude that in zone b weed pressure is heavier than that in zone a, independently of whether weed presence supposition is coloured with yellow or green hues. Due to this conclusion, the weed management treatment ought to differentiate between the two zones in terms of herbicide doses.

Yield data was recorded via a yield monitor mounted on a cotton picker at the end of the growing period. The yield was measured in point locations across the farm simultaneously with cotton harvesting and in retrospect with the use of geostatistical methods the map of Fig. 4 was produced. According to the yield map, the mean value of yield in zone a is 3710 Kg/ha and in zone b is 3824 Kg/ha. The direct linkage of weed presence, as



mapped with the three sensing systems used in this study, with the final yield would have rather ambiguous results as yield majorly depends on various factors like soil fertility, water availability, climatic conditions etc. It is sure though, that at the time of weed recording, competitive phenomena between weeds and cotton seedlings were suppressing cotton growth, which may not result in reduced yield due to farming practices.

#### 4. Conclusions

Decision making when referring to weed management is rather unjustified and random as far as the spatial distribution of weeds is concerned. Indeed conventional herbicide applications are based on whole field approaches ignoring the fact that weeds grow on patches and do not cover the entire extend of a field.

In Greece the majority of farmers follow conventional methods in applying agronomic inputs. Current and ongoing technology advances in sensing systems, permits the reliable remote monitoring and management of weed flora in a field scale and enhances the ability of producing weed distribution and herbicide application maps.

#### Acknowledgements

*The authors wish to thank Dr. S. Stamatiadis (Goulandris National History Museum) for providing the groundbased sensors and the Institute of Soil Mapping and Classification (NAGREF) for sharing yield data and map.*

#### References

- Gerhards, R., Oebel, H., 2006. *Practical experiences with a system for site-specific weed control in arable crops using real-time image analysis and GPS-controlled patch spraying*. Weed Research, 46, 185-193.
- Kalivas, D., Vlachos, C.E., Economou, G., Dimou, P., 2012. *Regional mapping of perennial weeds in cotton with the use of geostatistics*. Weed Science, 60 (2), 233-243.
- López-Granados, F., 2011. *Weed detection for site-specific management: mapping and real-time approaches*. Weed Research, 51, 1-11.
- Tellaeche, A., BurgosArtizzu, X.P., Pajares, G., Ribeiro, A., Fernandez-Quintanilla, C., 2008. *A new vision-based approach to differential spraying in precision agriculture*. Computers and Electronics in Agriculture, 60, 144-155.



**Session 3:**  
Advanced sensors systems  
in agricultural environments





TOPIC n° 2.2

**An empirical study on the suitability of SURF algorithm for  
features detection and video stabilization in crop fields**

**Nadir Sainz-Costa<sup>1</sup>, Xavier P. Burgos-Artizzu<sup>2</sup>, P. Javier  
Herrera<sup>1</sup>, Angela Ribeiro<sup>1</sup>**

<sup>1</sup> *Center for Automation and Robotics (CAR). UPM-CSIC. Crta. Campo Real km. 0.2  
– 28500. Arganda del Rey. Madrid. SPAIN (e-mail: nadir.sainz | pj.herrera |  
angela.ribeiro@csic.es)*

<sup>2</sup> *Computation and Neural Systems, 136-93. California Institute of Technology. 1200  
East California Boulevard, Pasadena, California 91125, USA*

**Keywords:** Image stabilization, Computer Vision, SURF  
algorithm.

---

**Abstract:** Precision Agriculture relies on images taken by moving platforms as one of its main data sources. The obtained video sequences are unstable and, therefore, the stabilization stage becomes important. This paper presents a comparison between a previously developed method based on crop row detection and a new approach using the SURF algorithm. The obtained stabilization is successful and implies an improvement in areas where previous methods showed poor performance.

---

## 1. Introduction

Precision Agriculture aims to increase the efficiency of field management techniques and reduce their operating costs. Automation of tasks is one of the main strategies adopted and, in the context of the RHEA EU project, it involves the use of autonomous platforms to perform agricultural operations. Gathering of the required data relies on the use of cameras mounted on moving platforms (continuous sampling) and, due to the roughness of the terrain, Image Stabilization becomes a crucial step in the process. When applied to video sequences, stabilization consists in the measurement and removal of the undesired motion present between the frames of the sequence. In the context of Precision Agriculture, where cameras move



constantly through the field, stabilization cannot rely on permanent punctual features in the frames.

A previous work (Sainz-Costa et al., 2011) proposes a stabilization method for crop fields based in the detection and tracking of the crop rows present in the different frames of a sequence. The algorithm works correctly under standard crop situations, but fails when there are sowing errors (absence of plants in one or more crop rows in a field area) or excessive weed infestation (in such a way that the spacing between crop rows is covered with weeds).

The SURF (Speeded-Up Robust Features) algorithm (Bay et al., 2008) is a local features detector partially based on the SIFT (Scale Invariant Features Transform) algorithm (Lowe, 1999) but faster and more appropriate for real-time applications. SURF based stabilization is not yet extensively applied. It has been used under controlled lighting conditions (indoors) and with frames that present clearly identifiable objects (Pinto and Anurenjan, 2011).

In Precision Agriculture applications cameras are constantly travelling through the field (image features changing continuously) and present very similar features, what makes their identification and description more complex. In this context, SURF feature description may become an important advantage. In this paper, a comparison between the previously mentioned method (Sainz-Costa et al., 2011) and a SURF based stabilization method is carried out.

## **2. Algorithm descriptions**

Video sequences of maize fields are recorded, at 25 frames per second (fps), with a camera mounted on a moving tractor (6Km/h) looking forwards and slightly to the ground. Images are taken under perspective, and there is no horizon line or point features that last over any appreciable time lapse. Independently of the used Stabilization Algorithm, the idea is to calculate the amount of undesired movement between subsequent frames of the video sequence in order to compensate it and obtain a smooth as possible sequence of frames.

## **2.1 Crop row detection based stabilization method**

The first algorithm in the comparison (Sainz-Costa et al., 2011) consists of three main steps: 1 – frame segmentation; 2 – crop rows detection and tracking, and 3 – perspective transformation to obtain a bird's eye view of the crop rows, which remain centered on the image (stable).

In that case, the crop rows were chosen as features to detect and track because of the absence of any other fixed features in the images. This work showed successful results for standard field areas, but performed much poorly in complicated areas which present a high weed coverage or sowing errors which prevent the algorithm to detect the crop rows and track them through the video sequence.

## **2.2 SURF based stabilization method**

The SURF algorithm is composed of 2 main phases: 1 – detection of maxima of the determinant of the Hessian matrix for different scales and 2 – generation of unique descriptors for the points found.

First the image is convolved with the Gaussian second order derivatives (at a scale  $\sigma$ ) to obtain the Hessian matrix at every pixel and its determinant is computed. The process is repeated for different scales  $\sigma_i$ . The pixels where the determinant of the Hessian matrix is a local maximum become the keypoints.

The second phase consists in the generation of a unique descriptor for each found keypoint, so that it is possible to identify and track them throughout the sequence. This descriptor is constructed using the Haar wavelet responses in  $x$  and  $y$  of the pixels in the neighbourhood of every keypoint. It is both, scale and orientation invariant.

The proposed stabilization method works by extracting SURF features for a frame, storing them with their descriptors and finally matching them to those extracted for a subsequent frame. The features that correspond to the same point in the different frames would be aligned in a stable sequence, and therefore their



coordinates are subtracted to compute their change in position.

The observed image motion can be intentional (vertical motion due to the camera travelling through the field) or unintended (horizontal oscillations caused by terrain roughness). Only unintended (horizontal) displacements are removed by the algorithm.

### 3. Results

The algorithms have been tested using three video sequences artificially generated to simulate the motion of a camera travelling through the field, but always showing a specific field area to test problematic situations: standard crop rows, sowing errors and high weed infestation.

The distance between the central crop row and the image horizontal center has been represented graphically for the two compared algorithms in the three mentioned situations, in order to achieve a proper comparison between both methods. Artificially generated motion is also represented. Figure 1 shows the standard case, where both algorithms perform well.

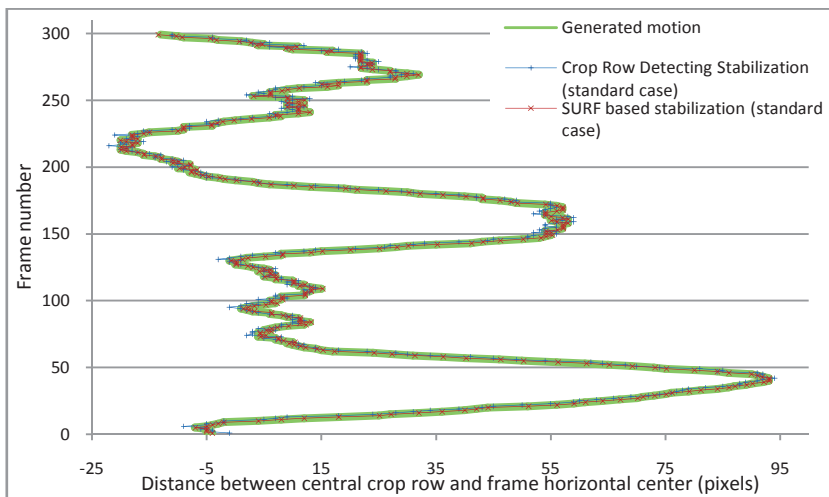

Fig. 1. Stabilization results for a standard field area where crop rows are easily identifiable. Both algorithms work properly.

More complex cases follow, where weed presence is very high (Fig. 2) or there have been sowing errors (Fig. 3). Here the crop

row detection algorithm fails, and stabilization is not achieved. The SURF based algorithm performs with no problems.

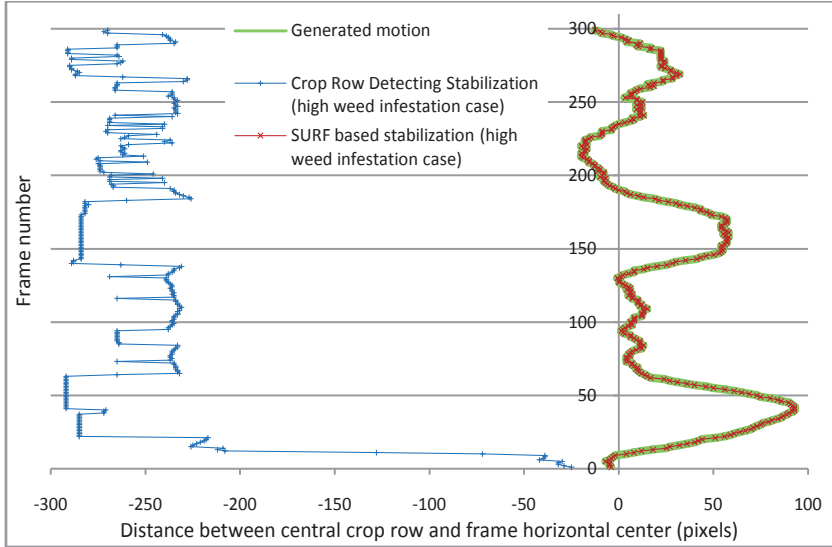

Fig. 2. Stabilization results for a field area where weed infestation is high. Only SURF based stabilization is successful.

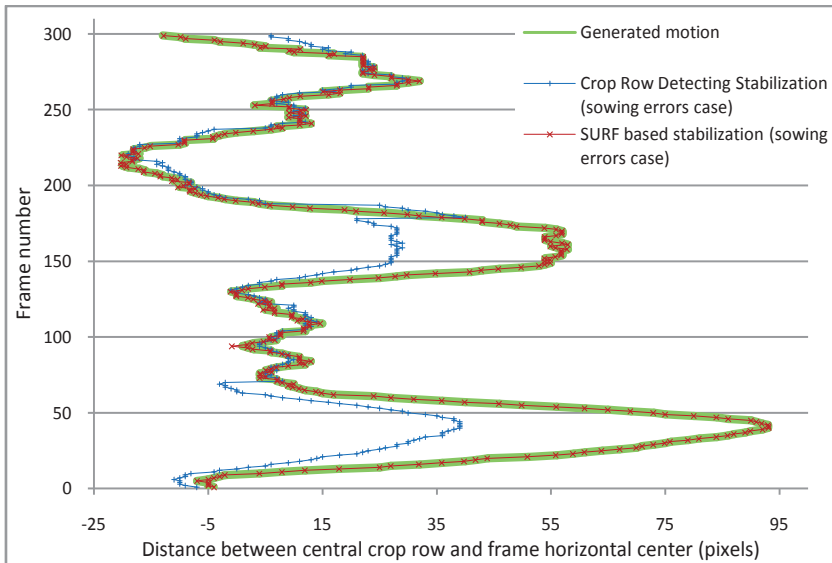

Fig. 3. Stabilization results for both algorithms in a problematic field region where there have been sowing errors.





## 4. Conclusions

The presented results show the advantages of the SURF based stabilization method over the previously developed method in complicated situations where the crop rows cannot be easily identified for the artificially generated sequences. The SURF based method achieves full stabilization in all tested cases.

One aim of Precision Agriculture is the automation of field operations. This requires algorithms that can deal with all kinds real situations. In this aspect, the proposed approach based on the SURF feature extraction algorithm is an improvement over the previously employed method.

However, computation times for the SURF based algorithm are larger than those required by the crop row detection stabilization, and so must be improved to apply the developed method in real-time operations.

The analysis for real video sequences recorded in the field, has not been finished yet. In that case, local features detected in one frame quickly disappear as the camera moves through the field. New features have to be extracted for each frame (or given number of frames) which generally implies higher computational costs.

## Acknowledgements

*This work is funded by the RHEA European Project, included in the EU 7th Framework Programme under contract number NMP2-LA-2010-245986, and by the Plan Nacional AGL2011-30442-C02-02: Ground inspection systems in unmanned ground vehicles and their effective application in Weed detection for site-specific control (GroW)*

## References

- Bay, H., Ess, A., Tuytelaars, T. and Van Gool, L. (2008). Speeded-Up Robust Features (SURF). *Computer Vision and Image Understanding*, 110, 346–359.
- Lowe, D.G. (1999) *Object Recognition from Local Scale-Invariant Features*. The Proceedings of the Seventh IEEE International Conference on Computer Vision, 2, 1150 – 1157.
- Pinto, B., Anurenjan, P.R. (2011) *Video stabilization using Speeded Up Robust Features* International Conference on Communications and Signal Processing (ICCSP), 527 – 531.
- Sainz-Costa, N., Ribeiro, A., Burgos-Artizzu, X.P., Guijarro, M. and Pajares, G. (2011) Mapping Wide Row Crops with Video Sequences Acquired from a Tractor Moving at Treatment Speed. *Sensors*, 11 (7), 7095 – 7109.



**First RHEA International Conference on  
Robotics and associated High-technologies  
and Equipment for Agriculture**  
Hosted by the University of Pisa  
Pisa, Italy, September 19-20-21, 2012



TOPIC n° 2.2: Computer vision and image analysis in agricultural processes

Automatic analysis of droplet impact by high speed imaging

Thomas Decourselle<sup>1</sup>, Frédéric Cointault<sup>1</sup>,

Ludovic Journaux<sup>1</sup>, Fan Yang<sup>2</sup>

<sup>1</sup>*Agrosup Dijon, 26 Bd Docteur Petitjean, BP 87999, 21079 Dijon Cedex, France*

<sup>2</sup>*LE2I, UFR Sciences et Techniques, BP 47870, 21078 Dijon Cedex, France*

**Keywords:** high speed imaging, spraying application, Weber number, active contours

---

**Abstract:** The impact of agricultural activities on the water quality is the consequence of the loss of fertilisers (chemical fertilisers, livestock effluent, also referred to as farm fertiliser, food-processing effluent and sludge) and crop treatment products (phytosanitary products). This pollution may prevent certain uses of water, notably its use for human and animal food (groundwater and surface water), and leads to a deterioration in aquatic environments. In the domain of vineyard precision spraying research, one of the most important objectives is to minimize the volume of phytosanitary products. It is also to be more environmentally respectful with more effective vine leaf treatments. Thus the main goal is to be sure that the spray reaches the target to reduce losses that occur. Mechanisms of losses by drift are now well known, in contrary of runoffs on the leaves. To enable a better decision making by the wine-grower in order to optimize the spraying management, it is essential to provide a set of information on basic parameters such as diameter and speed of the droplet. These last ones are used in the calculation of the Weber number. The Weber number is a dimensionless number used in fluid mechanics that is often useful in analysing fluid flows where there is an interface between two different fluids, especially for multiphase flows with strongly curved surfaces. It can be thought of as a measure of the relative importance of fluid's inertia compared to its



surface tension. To go further in the analysis of the droplet's behaviour after the impact with the leaf, the contribution of motion information obtained thanks to high speed imaging technology is a relevant solution. In the past, the different behaviours such as adhesion, bounce or splash were manually determined by the observer. Our tracking method based on "active contours" technic allows us to automatically detect the behaviour and to collect informations about the droplet in order to compute its Weber number.

---

## 1. Introduction

In the domain of spraying research, one of the most important objectives is to optimize the volume of phytosanitary products reaching the leaves in order to be more environmentally respectful with more effective plant treatments. Any product not deposited on the target is called "wastage". Wastage includes drift (vapour and droplet), run-off and any off-target deposition. In high volume airblast applications studies show that 80 per cent of the product can be lost to drift and ground deposition (Deveau et al. 2009). Wastage not only costs time and money but may reduce the effectiveness of the application and increase the risk of environmental contamination. Thus, the main goal is to be sure that the spray reaches and stays on the target in order to reduce losses that occur at the application. Mechanisms of losses by drift are now well known (Schampheleire et al. 2008), contrary to runoffs on the leaves. These last ones are related to adhesion mechanisms of liquid on a surface. Specific models have been developed (Forster et al. 2005) and showed that the predominant factor is leaf roughness, for which few robust works and models have been carried out. In a precision spraying context, our work aims at analysing droplets behaviour on the leaves, as adhesion, bounce or splash, and to link it in a second stage with leaf surface features, particularly its roughness. Therefore, our study stands on two main parts; on one hand we have to perform an analysis of the surface and on the other hand we have to analyze the droplet and its behaviour (Fig. 1).

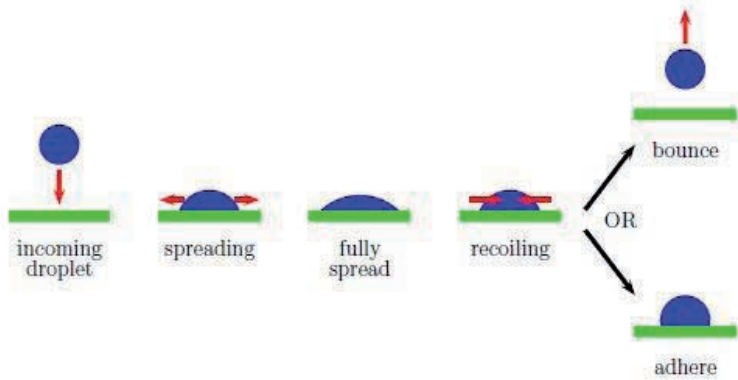

Fig. 1. Schematic diagram showing adhesion and bounce of a droplet (Mercer & Sweatman 2006).

In this article we focus on analysing behaviours of the droplets. Depending on the air-blast sprayer used but also on the parameters chosen by the user, we can observe a large range of values for velocity and diameter of the droplet defining different values for kinetic energy. Diameter is between 100 and 400  $\mu\text{m}$  and velocity is between 1 and 13 m/s (Gauvrit 1996). This implies a real challenge by tracking very small and high speed moving objects.

The recent improvements in digital image processing, sensitivity of imaging systems and cost reduction have increased the interest in high-speed imaging techniques for spraying applications.

## 2. Material

At the beginning a piezoelectric system was used in order to generate droplets with different sizes and velocities. Although droplet sizes correspond to real sizes observed in spraying applications, velocities are lower with values under 1.25 m/s which are not in correlation with real values observed in the vineyards. In order to overcome these difficulties we choose to use an industrial sprayer with an appropriate kit of nozzles. In these conditions we get closer to real spraying conditions.

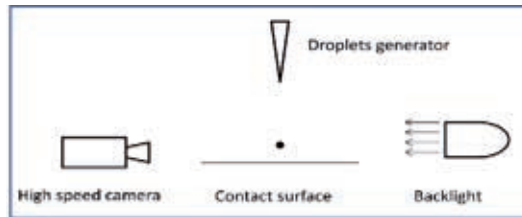

Fig. 2. Scheme of the system.

At this moment droplets are generated with appropriate sizes and velocities, we have now to prepare an optical system (Fig.2) able to get accurate values for droplet parameters and behaviours. A 50 mm lense is used with extension tubes, in these conditions distorsion can be considered as null and spatial resolution is enough to correctly see small droplets. Exposure time need to be less than  $16 \mu\text{s}$  in order to get non blurry image and allow extraction of correct information on size and velocity. The main problem with this small exposure time is the need of a high power illumination source. A 500 W halogen was firstly used to bring enough illumination but it becomes also a source of problem with important heat release which causes leaf roughness deterioration. Another problem with the halogen is the non-homogeneity of the lighting which can be sources of mistakes in tracking algorithm. In order to solve these problems we choose to use high-power leds lighting system made up of tri-star led with diffuser.

### 3. Methods

Firstly we perform an inversion of the image in order to get high intensity values for the pixels belonging to the droplet. Then we apply the background subtraction which allows us to detect only moving objects in the scene. We have now to track these objects from frame to frame. In this purpose, we use a combination of two methods: shape matching and contour tracking.

We consider two main stages in the video which are the times before impact and times after impact. Before impact, we use an algorithm of shape matching considering that the droplet keeps a circular shape.

We compute an area-perimeter ratio  $I$  defined as:

$$I = \frac{4\pi\mathcal{A}}{\mathcal{P}^2} \quad (1)$$

with  $\mathcal{A}$ : area of the object,  $\mathcal{P}$ : perimeter of the object.

If  $I$  is equal to 1, the object has a circular shape and we can order to take into account small deformations of the droplet.

Once the droplet reaches the surface, it is subject to bigger deformations during the steps of spreading and recoiling. It is now not possible to use shape matching for tracking the droplet. We use then contour tracking technique named Active Contour, also known as Snake method. The development of active contour models results from the work of Kass, Witkin, and Terzopoulos (Kass et al. 1988). A snake is an active (moving) contour, in which the points are attracted by edges and other image boundaries. To keep the contour smooth, a membrane and thin plate energy is used as contour regularization. Basically, snakes are trying to match a deformable model to an image by means of energy minimization. The energy functional which is minimized is a weighted combination of internal and external forces. The internal forces emanate from the shape of the snake, while the external forces come from the image and/or from higher level image understanding processes. The snake is parametrically defined as  $v(s) = (x(s), y(s))$ , where  $x(s), y(s)$  are  $x, y$  coordinates along the contour and  $s$  is from  $[0,1]$ . The energy functional relative to the snake is written:

$$E_{snake} = \int_0^1 E_{int}(v(s)) + E_{image}(v(s)) + E_{con}(v(s)) ds \quad (2)$$

- $E_{int}$ : internal energy due to bending which serves to impose piecewise smoothness constraint.
- $E_{image}$ : image forces pushing the snake toward image features (edges, lines, terminations).
- $E_{con}$ : external constraints are responsible for putting the snake near the desired local minimum.

We can see in Fig. 3 an example of a tracked droplet.

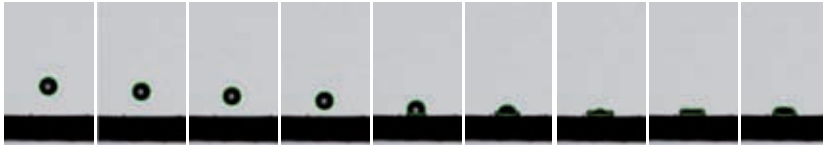

Fig. 3. Sequence of droplet impact with adhesion.

#### 4. Conclusion

In this article we present an acquisition system for water droplet impact observation and an automated method for extraction of droplet parameters and behaviours. Thanks to obtained data we can accurately characterize incoming droplets with their Weber number which represents a measure of the relative importance of fluid's inertia compared to its surface tension. These Weber number are related to specific behaviours of the droplet such as adhesion, bounce or splash.

Now we have to generate more droplets with different sizes and velocities in order to find the two critical Weber numbers defining the transition between adhesion and bounce as well as the transition between bounce and splash. It could be also interesting to see the evolution of these numbers with the growing of the vine leaf, and particularly its roughness which can be characterized by texture features as Generalized Fourier Descriptors (Decourselle et al. 2010).

#### References

- Decourselle, T. et al., 2010. *Vineyard leaf roughness characterization by computer vision and cloud computing technics*. In International Conference on Agricultural Engineering - AgEng- 6-8 September 2010. Cemagref.
- Deveau, J., Ontario. Ministry of Agriculture, F. & Affairs, R., 2009. *Six Elements of Effective Spraying in Orchards and Vineyards*, Ontario, Ministry of Agriculture, Food and Rural Affairs.
- Forster, W.A., Kimberley, M.O. & Zabkiewicz, J.A., 2005. A universal spray droplet adhesion model. *Transactions-American Society of Agricultural Engineers*, 48(4), p.1321.
- Gauvrit, C., 1996. *Efficacité et sélectivité des herbicides*, Editions Quae.
- Kass, M., Witkin, A. & Terzopoulos, D., 1988. Snakes: Active contour models. *International journal of computer vision*, 1(4), p.321-331.
- Mercer, G. & Sweatman, W., 2006. *Process Driven Models for Spray Retention of Plants*.
- Schampheleire, M. et al., 2008. Effects on pesticide spray drift of the physicochemical properties of the spray liquid. *Precision Agriculture*, 10, p.409-420.





**TOPIC n°2.2**

**IN-FIELD ACCURATE APPLE FRUIT DETECTION  
USING STANDARD DIGITAL CAMERA  
AND ROBUST IMAGE ANALYSIS PROCESSING**

**EHRET, C.<sup>1</sup>, GUIZARD C.<sup>2</sup>,  
GOBRECHT A.<sup>3</sup>, BOUNIOL, M.<sup>4</sup>**

*1 2 4 IRSTEA, UMR ITAP 361 rue JF Breton BP 5095 34196 Montpellier Cedex 5, France*

*4 CEHM, Mas de Carrière - 34590 Marsillargues, France*

**Keywords:** apple - image analysis - image processing - yield prediction

---

**ABSTRACT**

The following article proposes a self-adaptive method for estimating the number of apples in color images acquired in orchards under natural lighting conditions. The method combines a specific technique to obtain constant quality of images, and an algorithm based on a pre-segmentation in the color space for a multivariate classification for the identification of fruits on the tree. The performance of the algorithm is investigated using a dataset of 4367 fruits (50 images). The algorithm detects about 92% of the apples visible in the images, with less than 5% false positive detections.

---

**1. Introduction**

In a context of sustainable agriculture leading to reduced use of pesticides, it becomes necessary to find alternatives to the most impacting products and progressively withdrawn from the market. This is particularly the case for some active substances used for chemical thinning of apples in order to optimize the intensity of chemical and manual thinning. Today, professionals assess the load of a tree by manually counting the apples on a part of selected trees. This method is time-consuming and the small sample of trees that can be inspected is statistically



unrepresentative (Vaysse et al., 1996). Detection of fruits using computer vision has been tested in numerous studies reviewed by Jimenez et al. (2000). The technologies used are varied: 3D laser or stereo localization, hyperspectral imaging (Safren et al., 2007), thermal infrared imaging (Stanjko et al., 2003), controlled artificial lighting conditions (Just et al., 1991), but color imaging remains the most used tool. In addition, the object being studied is complex: a tree, with leaves and branches, visually more or less porous, revealing other objects from the background that one do not necessarily wants in the processed image (Linker et al., 2012). This work presents an image acquisition device associated with an image analysis classification algorithm, allowing automatic detection, whatever the lighting conditions.

### 1. Materials and methods

The work here presented is based on experiments conducted between 2009 and 2012 in the experimental orchard of CEHM<sup>1</sup>. The device is composed of a CANON Powershot G10 Camera (F:28mm diaphragm) and Mecablitz-mb-45cl flash.

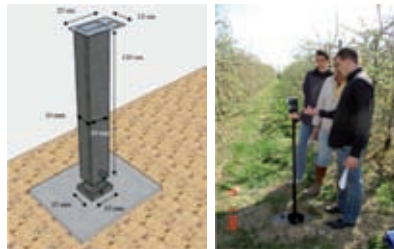

**Fig. 1 : Metal support for the camera**

The camera was placed at a height of 1.20m above ground, at a distance of 2 m from the tree. Using a high power flash as a source of artificial lighting provides images of repeatable quality with good contrast (Fig. 2) and eliminates possible unwanted background.

---

<sup>1</sup> CEHM : Centre expérimental horticole de Marsillargues Mas de Carrière - 34590 Marsillargues FRANCE N43°37'55.92",E004° 9'44.63



**Fig. 2 : normal image (left), Irstea acquisition (right)**

The image processing was performed directly on Jpeg encoded images (2592x1944 - minimal compression) on a Dell PC, running Labview 9.0 environment.

**2. Analysis of the image content**

In their article, Stajnko et al. (2005) or Linker et al. (2012) propose an apple segmentation method using color, shape and texture criteria. Our approach does not consider the color of the apple as a discriminating factor because at this stage, apples are often of the same color as the leaves.



**Fig. 3 : Examples of fruits to be detected**

Our approach consists to find successively these three classes (Fig. 4).

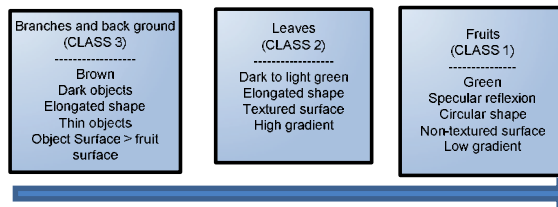

**Fig. 4 : Image objects class**

**3. Description of the algorithms**

*Step 1: Class 3 determination*

Our approach is purely colorimetric and is based on the work of Van de Sande et al, (2010), which shows that the color space is sufficient (Hue component of HSL space). This first step does



not attempt to separate the apples but attempts to robustly separate the class of branches from all the other objects that are not "green" (Fig. 5).



**Fig. 5 : before and after segmentation**

*Step 2 : Class 2 determination*

Class 2 contains objects that are close to apples in color and shape, like parts of the leaves that reflect the same color spectrum as apples. It is therefore necessary to find a robust model for discriminating these two classes, one of these being the class apple. We chose a multivariate classification based on texture and certain shape factors like elongation. To build our model, we have created a database of 287 representative samples of objects to be classified. To perform the classification, we have based our work on a supervised learning by an expert trained on three classes: apples, leaves and other. A principal component analysis (PCA) allowed us to select the most discriminative descriptors of our object classes (leaf, apple, etc.). The classification model is then been calculated by Factorial Discriminant Analysis (FDA) to determinate the weight of each descriptor over one of the two axes by maximizing the interclass variance.

Our space consists of two axes LD1 and LD2 as:

Coefficients of linear discriminants:		
	LD1	LD2
Energie	-0.858454206	12.115117361
Inertie	18.975977610	14.655807073
Entropie	-0.410630991	-3.938005080
Correlation	22.392225316	1.414983719
Ecart.type	0.040353617	-0.031679630
Elongation	0.014709369	-0.881821595
Centroide	0.003616121	-0.003170937
Mean_H	0.170155226	0.032211686
Mean_S	-0.004557601	0.009878823
Kurtosis	-0.018272209	-0.004526122

### Step 3: Class 1 determination

The definitive class of an object will be assigned using the Mahalanobis distance (Mahalanobis, 1936) between the object and the center of gravity of each class.

## 4. Results and conclusions

The program was tested (Fig. 6) on a library of 50 files (4367 apples have been counted manually). The algorithm found 3990 apples (5% false fruit detection, 12% undetected fruits) (Fig. 7).



**Fig. 6: Treatment on the image : Image31Nuit20090526**

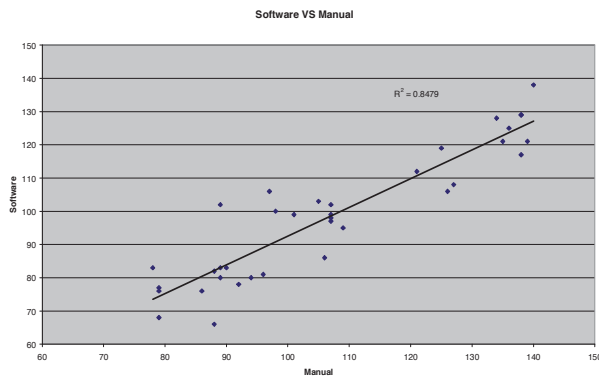

**Fig. 7 : Manual count VS automatic**

The algorithm is capable of automatically detecting fruits even if they are partially hidden (Fig. 8).



**Fig. 8 : Example of fruit detection performance (~40mm)**



## 5. Conclusion

This work shows that it is possible to count apples of a diameter range from 30mm to 100mm, in orchard, using a simple and inexpensive device (digital camera + flash) in conjunction with a multivariate classification algorithm. Automatic counting should improve the representativity of the field measurements and provide greater flexibility as compared to the manual counting methods currently performed by the growers. In the future, it could be possible to employ this type of device on a tractor in order to analyze a whole orchard. The device is still being tested, focusing on the detection of small fruits (less than 20mm), a task which represents a new challenge where other methods could improve the performance of the method presented in this article.

## Acknowledgements

*This work is done under the CASDAR project n° AAP2008-8039 managed by the CTIFL .*

## References

- Stajanko D, Lakota M, Hoèvar M. (2004). *Estimation of number and diameter of apple fruits in an orchard during the growing season by thermal imaging*. Computers and Electronics in Agriculture 42, 31-42
- Stajanko, D.; Rakun, J.; Blanke, M. (2009). *Modeling apple fruit yield using image analysis for fruit colour, shape and texture*, European Journal of Horticultural Science, 74 n°6 , 260-267
- Jimenez A.R., Ceres R., Pons J.L. (2000), *A Survey of Computer Vision Methods for Locating Fruit on Trees*, Transaction of the ASAE, 43(6), 1911-1920
- Juste F., Sevilla F. (1991). *Citrus: A European project to study the robotic harvesting of Oranges*, Proc. 3rd Int.Symp. Fruit, Nut and Vegetable Harvesting Mechanization, 331-338
- Rabatel G., A.Bourelly (2000). *Récolte automatisée des pommes et des agrumes*. Applications non manufacturières de la robotique, DAUCHEZ Hermès, Paris, 47-55
- Van de Sande, K.E.A.; Gevers, T.; Snoek, C.G.M.; (2010), *Evaluating Color Descriptors for Object and Scene Recognition, Pattern Analysis and Machine Intelligence*, IEEE Transactions on , 32 no.9, 1582-1596
- Mahalanobis P. C. (1936). *On the generalized distance in statistics*, Proceedings of the National Institute of Sciences of India, 2 no 1, p. 49-55
- Linker R., Cohen O., Naor A. (2012). *Determination of the number of green apples in RGB images recorded in orchards*, Computers and Electronics in Agriculture, 81,45-57



TOPIC n° 2.2

## Influence of the vision system pitch angle on crop and weeds detection accuracy

José Miguel Guerrero<sup>1</sup>, Juan Romeo<sup>1</sup>, Luis Emmi<sup>2</sup>,  
Martín Montalvo<sup>3</sup>, María Guijarro<sup>1</sup>, Gonzalo Pajares<sup>1</sup> and  
Pablo Gonzalez-de-Santos<sup>2</sup>

<sup>1</sup> Dpt. Software Engineering and Artificial Intelligence, Faculty of Informatics,  
University Complutense of Madrid, Spain (email: jmguerre@fdi.ucm.es)

<sup>2</sup> Centre for Automation and Robotics, UPM-CSIC, Arganda del Rey, Madrid, Spain

<sup>3</sup> Dpt. Computers Architecture and Automatics, Faculty of Informatics, University  
Complutense of Madrid, Spain

**Keywords:** *Camera system geometry, pitch angle variation,  
crop and weeds densities, perspective projection.*

---

**Abstract:** In Precision Agriculture, a common practice consists of the image processing for weeds/crop identification to eliminate the first ones. The positioning of the vision system is an important aim because it determines the accuracy during the identification. This study has intended to select which is the best position to get the necessary accuracy. This paper analyses the dependency of the accuracy of green density detection of crop and weeds based on the variation of the camera pitch angle. Analytical results are then applied to images of maize fields under a simulated environment.

---

### 1. Introduction

The use of robotics systems, equipped with vision-based sensors, for site specific treatments in Precision Agriculture is in continuous growth. A common practice consists of the image processing for weeds/crop identification to control the first ones. Because of the similar spectral components displayed for both types of plants, greenness extraction plays an important role. The crop row and weed detection is an important issue related with the application of machine vision methods in agriculture, it





has attracted numerous studies in this area (López-Granados, 2011; Montalvo et al., 2012; Guerrero et al., 2012, Romeo et al., 2012). Ratios of greenness and soil determine what is known as density. The goal is to detect crop/weeds densities from the spectral components associated to pixels in the image. Based on density values, it is possible to determine if a specific treatment is required for weeds control. Hence, accuracy on this calculation may be critical.

The vision system is installed on-board a tractor and depending on its positioning and orientation different density accuracy values are obtained for the same distribution of plants in a selected area in the field. Because of physical limitations, the camera localization cannot be placed with a pitch angle of  $90^\circ$  (zenith orientation), although it is the best orientation for density accuracy. Hence, the pitch angle must be conveniently selected for achieving the best accuracies.

Intrinsic and extrinsic camera parameters (Fu et al., 1988) are critical for densities estimation. This paper analyses the accuracy dependency with respect the pitch angle. That is, for a given camera-based system with its own intrinsic and extrinsic parameters in a fixed position on the tractor and at a fixed distance of the region to be imaged, the goal is to analyse accuracy on densities by varying only the pitch angle via a simulated environment with a real camera model. This allows to determine the best camera arrangement to make more accurate decisions in real environments. This makes the main contribution of this work.

## 2. Materials and methods

In order to analyse the arrangement of the vision system under different pitch angles, a CCD-based device camera SVS4050CFLGEA (SVS-VISTEK, 2012) model is used for simulation, i.e. a digital colour camera with size resolutions of  $2336 \times 1752$  pixels with pixels-sizes of  $5.5 \times 5.5 \mu\text{m}$ . This camera is equipped with an optical system of 10mm of fixed focal length.

In addition to the camera model, we have also modelled the crop field, in this case maize. Both models have been implemented in a simulated environment oriented to study and evaluate the execution of agricultural tasks that can be performed by an autonomous robot as part of a fleet of robots (Emmi et al., 2012). One of the main features of this simulation environment, which is based on the Webots tool (Cyberbotics, 2012), is the ability for representing and modelling the characteristics of the field in a three-dimensional (3D) virtual universe.

The procedure used for the intended evaluation consists of the definition of a simulated scenario built with crop rows that are spaced 0.75m, one from each other, with random patches of weeds, which is a common arrangement in maize fields. A fixed 2×2 meters square area in the field, red box in Fig. 1, is the specified zone captured with the camera under different pitch angles. The camera is placed at 2.2m above the ground and 3m away from the nearest side of the square, being that the minimum distance that can be reached without getting the front of the tractor in the image.

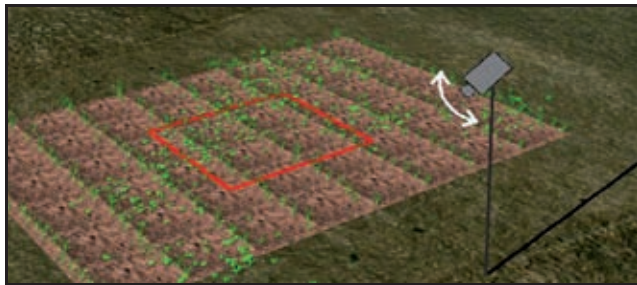

Fig. 1. A fixed 2×2m square area, red box, is captured by the camera with different pitch angles.

Different images of the same area are acquired with the only difference that the pitch angle of the camera is modified from one image to the other; this is achieved by varying the camera orientation following the double arrow in Fig. 1. In this study the distance to the red zone from the camera and the height from the ground remain constant. Figure 2, (a) to (c), displays three images acquired with pitch angles set to 18°, 30° and 42° respectively.



For every image we count the number of pixels inside the red area. Due to perspective projection, the size (surface) of this area varies depending on the pitch angle. To calculate crop and weeds densities of a specific area we compute the number of green pixels inside that area, where green pixels are obtained through the procedure described in Romeo et al. (2012). So, for performance analysis, we apply the following logical criterion: the bigger the size of an area in the image the better the accuracy.

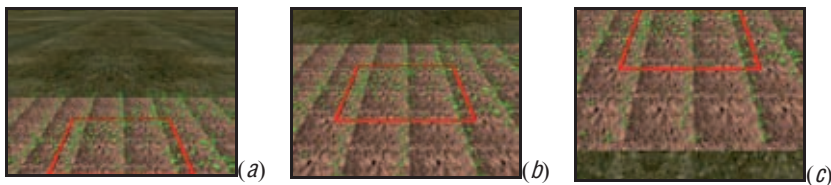

Fig. 2. Images of the same area acquired with the pitch angle set to  $18^\circ$ ,  $30^\circ$  and  $42^\circ$  for a), b) and c) respectively.

### 3. Results

This study is concerned with the camera arrangement for the ground perception system in the ground mobile unit working on maize fields in the project that belongs to the Seventh Framework Program, titled “RHEA - Robot Fleets for Highly Effective Agriculture and Forestry Management” RHEA (2012).

Table 1 shows different results for the nine images acquired of the area in the field mentioned above. Column two contains the different pitch angle values in degrees. Column three displays the different sizes of the area in the image; they are measured by computing the total number of pixels in the image inside the area. As already mentioned, this number of pixels depends on the pitch angle used during the image acquisition. In our experiments a pitch angle of  $90^\circ$  refers to the camera pointing perpendicularly to the area to be explored, i.e. with its optical axis perpendicular to the plane defined by the area (zenith arrangement). A pitch angle of  $0^\circ$  degrees would mean that the camera is parallel to the ground surface. In RHEA no zenith camera positions are proposed but pitch angles with possible variations ranging in  $[18^\circ, 42^\circ]$ . Thus, we normalize the values

with respect the highest number of pixels obtained for the red box, which corresponds to a pitch angle of 18°. Normalized values with respect to the reference one are displayed in the fourth column in Table 1.

Table 1. Nine images acquired with different pitch angles; number of pixels in the red box and their normalized values with respect the first image.

N° Image	Pitch angle (°)	Number of pixels inside the specified area	Normalization of the number of pixels inside specified area
1	18	696734	1.000
2	20	682099	0.979
3	22	670402	0.962
4	25	657700	0.944
5	30	649100	0.932
6	35	656084	0.942
7	38	667566	0.958
8	40	678790	0.974
9	42	692337	0.994

Figure 3 displays the size of the red area versus the pitch angle. We can see that the best angles to use are the ones where the area remains at the bottom of the image, i.e. pitch angle set to 18°, Fig. 1(a) or at the top of the image with pitch angle to 42° Fig. 1(c) and the worst angle would be where the area appears in the middle of the image, pitch angle set to 30°, Figure 1(b).

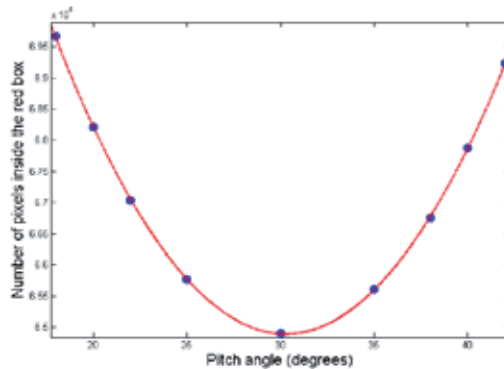

Fig. 3. Number of pixels in the red box displayed in Figure 1 with respect the pitch angle.



According to the normalized results displayed in Table 1, we can see how accuracy may vary up to a 6.8% of difference depending whether the chosen pitch angle is 18° degrees or 30° degrees respectively. This must be conveniently considered for camera arrangements trying always to design the system with the most favourable angles.

#### 4. Conclusions

Given a camera-based vision system, we have proved and estimated how green density calculation accuracy of crop and weeds depends on pitch angle, but on the same way, the accuracy of this calculation also depends on other extrinsic parameters including the roll and yaw angles, i.e. related to rotations and also the ones involving translations, such as distance of the selected area to the camera and the height of the camera. Additional experiments could be carried out in the future by combining different camera arrangements studying the variation of the different intrinsic and extrinsic parameters.

#### Acknowledgements

*The research leading to these result has received funding from the European Union's Seventh Framework Programme [FP7/2007-2013] under Grant Agreement n° 245986.*

#### References

- Cyberbotics. (2012). *Webots: robot simulator*. <http://www.cyberbotics.com/>.
- Emmi, L., Paredes-Madrid, L., Ribeiro, A., Pajares, G. and González-de-Santos, P. (2012). *Robot fleet for precision agriculture: A simulation environment*. Computers and Electronics in Agriculture. Submitted.
- Fu, K.S., Gonzalez, R. C. and Lee C.S.G. (1988). *Robótica: Control, Detección, Visión e Inteligencia*. McGraw Hill, Madrid.
- Guerrero, J.M, Pajares, G., Montalvo, M., Romeo, J., Guijarro, M. (2012). *Support Vector Machines for crop/weeds identification in maize fields*. Expert Systems with Applications, vol 39, issue 12, pages 11149-11155, doi: 10.1016/j.eswa.2012.03.040
- López-Granados, F. (2011). *Weed detection for site-specific weed management: mapping and real-time approaches*. Weed Research 51, 1–11.
- Montalvo, M., Pajares, G., Guerrero, J.M., Romeo, J., Guijarro, M., Ribeiro, A., Ruz, J.J., Cruz, J.M. (2012). *Automatic detection of crop rows in maize fields with high weeds pressure*. Expert Systems with Applications. (in press) doi: 10.1016/j.eswa.2012.02.117.
- RHEA (2011). <http://www.rhea-project.eu/>.
- Romeo, J., Pajares, G., Montalvo, M., Guerrero, J.M., Guijarro, M., Ribeiro, A. (2012). *Crop Row Detection in Maize Fields Inspired on the Human Visual Perception*. The Scientific World Journal, vol. 2012, article id 484390, 10 pages, doi:10.1100/2012/484390.
- SVS-VISTEK (2012). *The Focal Point of Machine Vision*. <http://www.svs-vistek.com/>.



**First RHEA International Conference on  
Robotics and associated High-technologies  
and Equipment for Agriculture**  
Hosted by the University of Pisa  
Pisa, Italy, September 19-20-21, 2012



TOPIC n° 2.2

Online dose optimization applied on tree volume through a  
laser device

Miguel Garrido<sup>1</sup>, Valeriano Méndez<sup>2</sup>, Constantino Valero<sup>1</sup>,  
Christian Correa<sup>1</sup>, Alejandro Torre<sup>1</sup>, Pilar Barreiro<sup>1</sup>

<sup>1</sup>*LPF-TAGRALIA. Universidad Politécnica de Madrid (UPM), CEI-Campus Moncloa.  
ETSI Agrónomos. Avda. Complutense S/N, Madrid. 28040. Spain (e-mail:  
[miguel.garrido.izard@upm.es](mailto:miguel.garrido.izard@upm.es))*

<sup>2</sup>*Dpto. de Matemática Aplicada a la Ingeniería Agronómica. Universidad Politécnica  
de Madrid (UPM), CEI-Campus Moncloa. ETSI Agrónomos. Avda. Complutense S/N,  
Madrid. 28040. Spain*

**Keywords:** Laser device, Dose optimization, SimLidar

---

**Abstract:** Nowadays, precision agriculture has allowed a spatial characterization in many common agricultural tasks. The use of this new agricultural tendency has enabled a reduction of inputs to be just applied or sprayed in places where they are needed.

Additionally to considering the spatial distribution within the field, it is also important to take into consideration the three-dimensional within these agronomical spaces. This second approach will enable an assessment within the selected areas with the objective of applying the correct dose according to the volume or target size.

By means of ultrasonic sensors, it is possible to apply phytosanitary treatments exclusively on the trees. Moreover, with the use of a LIDAR device that allows on-the-go calculation of leaf mass or volume for each tree detected, it would be possible to adapt the sprayed dose.

LIDAR data used during this study were obtained through the use of a tree and laser simulator software "SimLidar", which allowed the development of processed data without the necessity of any field trial.



## 1. Introduction

Portable ground-based scanning LIght Detection And Ranging (LIDAR) has several beneficial features. For instance, it is non-destructive and, because it is an active sensor, measurements are not affected by the light conditions in the field. Extensive 3-D data for a crop can be recorded quickly and automatically as 3-D point-cloud data, been applied to canopy measurements (Omasa et al., 2007; Campoy et al., 2010; Llorens et al., 2011).

All of these reasons make LIDAR the optimum device in order to study the vegetation cover for achieving an optimization of the spraying tasks.

## 2. Materials and methods

### *2.1 SimLidar (Tree and LIDAR simulator)*

SIMLIDAR (acronym for LIDAR simulation) is an application developed in C++ that generates an artificial orchard using a Lindenmayer (L-system) model. The application simulates the lateral interaction between the artificial orchard and a laser scanner or LIDAR. The scanner is mounted on a virtual tractor and measures the distance between the origin of the laser beam and the nearby plant target. This measurement is taken with an angular scan in a plane which is perpendicular to the route of the virtual tractor. SIMLIDAR determines the distance measured in a bi-dimensional matrix  $N \times M$ , where  $N$  is the number of angular scans and  $M$  is the number of steps in the tractor route (Méndez et al., 2012).

#### *2.1.1 L-system tree model*

An open L-system model is a technique used to produce a geometric description of the branching pattern for a typical pre-blossom tree structure.

L-system is an alphabetic string, where each letter of the alphabet represents the movement of an imaginary turtle that describes the tree. An iterative substitution process is used to obtain the final string of an L-system (Tarquis et al., 2006).



## 2.2 Data collection

For the development of this study apple trees were chosen, selecting an L-system model for their simulation. Table 1 shows the simulation parameters chosen for the trees, as well as for LIDAR simulation, being the reference axes: "x" referring to tractor advance; "y" horizontal depth; and "z" object height.

Table 1- Tree and LIDAR parameters selected

Tree Parameters		LIDAR parameters	
Number of iterations	5	Y and Z distance (mm)	1000
Number of trees	3	X increment (mm)	11
Shadow max. ratio	60	Angle Increase (degrees)	0.5

## 2.3 Minimal spraying pixel concept

In order to perform a variable dose, it is important to establish the minimum area over which the spray system can interact. This surface will be referred as *pixel*, and is defined as the lower surface on which spray system may act.

With the aim of obtaining the height of the pixel it is important to define the spraying system, since the range of action is defined by the number and type of nozzles. In this respect, a spray system of 4 nozzles was considered, with the following working heights for each nozzle: 0.4-1.0 m; 1.0-1.6 m; 1.6-2.2 m; 2.2-2.8 m.

For establishing the width of the pixel, the time required for the actuation system to adapt to a dose change should be taken into account. For this case, a tractor speed of 1.25 m s<sup>-1</sup> was considered, with a frequency of 5 Hz at the actuation system.

Figure 1 shows the pixel grid established at the simulated apple tree row, representing with different colors the actuation areas expected for each nozzle, as well as the tree area that is out of actuation range (in blue).

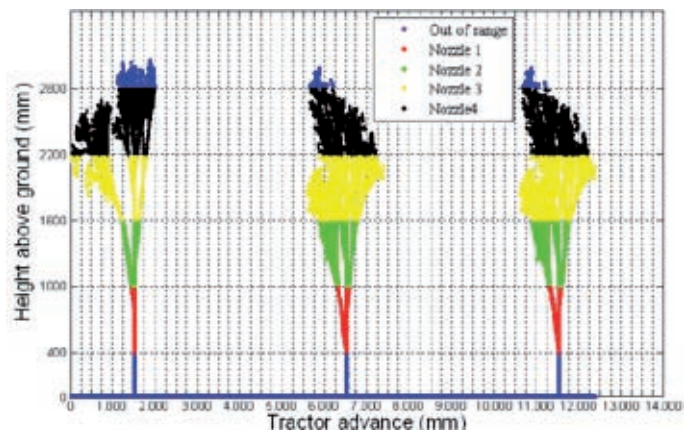

Figure 1. Minimum actuation areas (pixel) represented by different colors each spray nozzle.

#### 2.4 Tree volume detected within a spraying pixel

In each minimal spraying pixel defined, as show in previous figure, a different number of LIDAR records were detected. By considering that each one of the LIDAR records was represented by a rectangle defined by specific dimensions depending on the scan and actuation zone (nozzle), the sum of all of them will give the tree area detected for each of the actuation pixels.

The rectangle dimension that defines each LIDAR detection point was determined from: minimum distance between LIDAR points (tangent of LIDAR angular resolution x distance recorded) at each scan and nozzle area, for rectangle height; and distance between scan parameters selected on LIDAR simulation, for rectangle width (see Fig. 2).

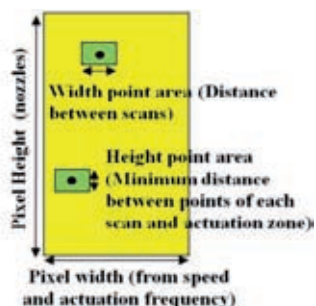

Figure 2. Pixel and point area dimensions

Based on the rectangles previously defined for each LIDAR detection, a third dimension will be added (depth, from the laser point of view), to obtain the prisms (*voxels*) that will define each of the LIDAR detections.

Considering a homogeneously simulated tree structure with a central location of the trunk in relation to the canopy, it could be possible to obtain prism depth ( $D_{\text{canopy}}$ ) by subtracting the distance value of the trunk ( $D_{\text{trunk}}$ ) to the laser mean distance value of each pixel ( $D_{\text{tree}}$ ).

As in the case of pixel tree area calculation, the pixel tree volume was calculated as sum of all prism volumes obtained from each LIDAR detection.

If spraying task will be performed from one tree row sides, the calculated volume has to be multiplied by two.

### 3. Results

Using the methodology presented in the previous sections and the input data obtained by the ‘SimLidar’ software, as well as ‘Matlab’ for data analysis, the following results were obtained (see Fig. 3 and Fig.4):

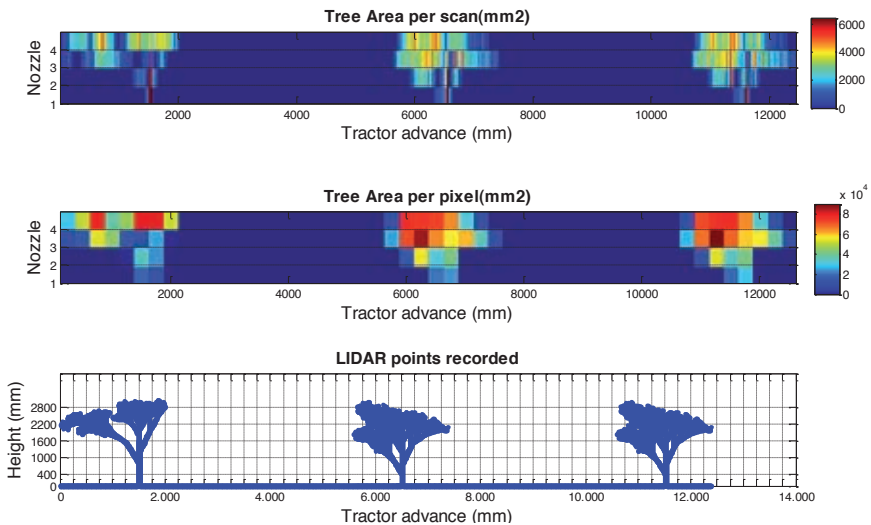

Figure 3. Scan (above), pixel (middle) tree area and LIDAR points detected (below)

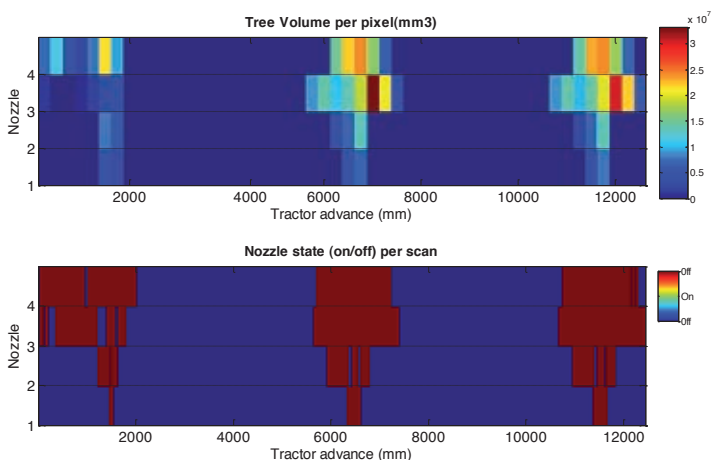

Figure 4. Tree volume per pixel (above) and nozzle state per scan (below)

#### 4. Conclusions

The methodology used within this paper could be transferred for adjustment of different agricultural treatments, as it would be the case of herbicide application, considering not only the location of the weeds patches, but also the size / volume of each of them, thereby achieving a greater application performance and with a more environmentally friendly approach.

#### Acknowledgements

*The research leading to these results has received funding from the European Union's Seventh Framework Programme [FP7/2007-2013] under Grant Agreement n° 245986.*

#### References

- Campoy, J.; Gonzalez-Mora, J.; Dima, C.S. (2010) Advanced Sensing for Tree Canopy Modeling and Precision Spraying. *ASABE Annual International Meeting, Pittsburgh, PA*, June 2010.
- Llorens, J.; Gil, E.; Llop, J.; Escolà, A. (2011) Ultrasonic and LIDAR Sensors for Electronic Canopy Characterization in Vineyards: Advances to Improve Pesticide Application Methods. *Sensors* 2011, 11, 2177-2194.
- Méndez, V.; Catalán, H.; Rosell, J.R.; Arnó, J.; Sanz, R.; Traquis, A. (2012) *SIMLIDAR* – Simulation of LIDAR performance in artificially simulated orchards. *Biosystems Engineering*, 111, 72-82.
- Omasa, K.; Hosoi, F.; Konoshi, A. (2007) 3D Lidar Imaging for Detecting and Understanding Plant Responses and Canopy Structure. *Journal of Experimental Botany*, 58, 881-898.
- Tarquis, A. M.; Mendez, V.; Walklate, P. J.; Castellanos, M. T.; Morato, M. C. (2006) L-system tree model and LIDAR simulator: estimation of spray target area. *WSEAS Transactions on Biology and Biomedicine*, 2006, 3, 81-88.



**TOPIC n° 2.2 Computer Vision and Image Analysis in Agriculture Processes**

## **Embedded Vision System for Real-Time Fruit Detection and Tracking**

**Marcel Tresanchez, Mercè Teixidó, Davinia Font, Tomàs  
Pallejà, Jordi Palacín**

*Department of Computer Science and Industrial Engineering, University of Lleida,  
Jaume II, 69, 25001, Lleida, Spain (palacin@diei.udl.cat)*

**Keywords:** Embedded vision system, fruit detection, fruit tracking.

---

**Abstract:** This work presents an embedded vision system designed for real-time fruit detection and tracking. The system is based on one STM32F407VGT6 microcontroller module and one Omnivision OV7670 color camera module. The complete system will be included in the hand of a robotized arm designed for automatic fruit harvesting. The main objective of the vision system will be the control of the robotic arm in order to pickup some selected fruits.

---

### **1. Introduction**

Automatic fruit detection in orchards has many useful applications such as the automatic harvesting estimation, the optimization of the application of agrochemicals, the estimate of the required harvesting time and the estimate of the expected yield. The work presented in (Jimenez et al., 2000) summarizes some approaches used to detect and locate fruit on a tree with applications such as automated harvesting of citrus (Pla et al., 1993), apples (Wachs et al., 2010), (Zhao et al., 2011), oranges (Plebe et al., 2001), peaches (Liu et al., 2011), etc. The strategies reviewed in (Jimenez et al., 2000) were mostly based on the application of image processing techniques to intensity, spectral and range images. Intensity and spectral images are mostly used when the fruit and the background are different but can be strongly affected by shadows and confusing regions.



This work proposes the development of an embedded vision system that will be part of an autonomous and automatic red peaches harvesting machine equipped with several robotized arms. The proposed vision system will be embedded in each one of the robotized arms in order to automatically pickup some selected fruits by performing individual fruit detection and tracking (Litzenberger et al., 2006), (Belbachir et al., 2007), (Anderson et al., 2007). The operation of each robotic arm will be guided by using a visual-loop control.

This proposal of embedded vision system is based on the use of a state of the art microcontroller from STMicroelectronics that is also based on ARM architectures. These cores were specifically designed for embedded and portable devices and currently most of the modern mobile phones and personal digital assistants contain ARM microcontrollers.

## **2. Materials and methods**

The main materials used in the embedded system are a processor board and a color camera module. Fig. 1 shows an image of both modules that also includes a complementary color LCD module for fast feedback and application verification.

### ***2.1 Processor board***

The processor board is based on the STM32F407VGT6 microcontroller unit (MCU) from STMicroelectronics that is based on the ARMv7-ME architecture inside the Cortex-M4F group of 32-bit RISC (reduced instruction set computing) and ISA (instruction set architecture) processor core developed by ARM Holdings.

The core of the selected microcontroller contains instructions to operate internally like a digital signal processor (DSP) and a floating-point unit (FPU) that operates in single precision by supporting all ARM single-precision instructions and data types. The microcontroller was configured to use an external crystal oscillator of 8 MHz that is internally converted in an operative frequency of 168 MHz (210 Dhrystone MIPS).

According to the manufacturer datasheet the microcontroller dissipates only 139mW while running at 100% CPU load which makes them particularly suitable for use in embedded and portable devices. The microcontroller requires different voltages from 1.8 to 3.6V that are obtained from the 5 VDC of one USB client connection. The processor board used in this work has two USB 2.0 On The Go (OTG) serial buses that can be configured either as host or clients, an internal 10/100 Ethernet MAC with dedicated DMA, a configurable 8 to 14 bit parallel camera interface that can operate up to 54 Mbytes/s, several general purpose DMAs, and up to 15 additional communications interfaces (I2C, UART, USART, SPI, CAN and SDIO). The processor board has 1 Mbyte of Flash memory, 192+4 Kbytes of SRAM including 64-Kbyte of Core Coupled Memory (CCM) data RAM, and has a flexible static memory controller supporting Compact Flash, SRAM, PSRAM, NOR and NAND external memories.

## ***2.2 Camera module***

The camera module is based on the Omnivision OV7670 color camera that is connected to one AL422B FIFO (first in first out) DRAM memory with 3 Mbits. This FIFO memory can store images of different resolutions from the camera without any MCU supervision. The images can be then sequentially accessed by the MCU. The VSYNC (vertical synchronism) signal of the camera is then used to generate an external interrupt in the MCU to inform that a new image is available in the FIFO memory that is blocked until the MCU enables a new image acquisition.

The OV7670 camera is controlled through a serial camera control bus (SCCB) with full user control over image quality (color saturation, hue, gamma, sharpness, edge enhancement, and anti-blooming) but also with automatic image quality functions. The camera has an array size of 656x488 pixels with a pixel size of 3.6  $\mu\text{m}$  x 3.6  $\mu\text{m}$  and can acquire images up to 640x480 active pixels (VGA size) in up to 30 frames per second (fps) in the following standard formats: YUV422, YCbCr422, RGB565, RGB555, GRB422, raw RGB, and raw Bayer RGB data. The camera can be configured to acquire images in VGA,





CIF (352x288 pixels) and any resolution lower than CIF. The camera requires different voltages from 1.8 to 3.0V and has a reduced power consumption of only 60 mW. Finally, the camera has a sensitivity of 1.3 V/lux·sec, an automatic flicker detection system and a flash strobe output that can be used to control and synchronize external LEDs or other dedicated illumination system, a feature that can be especially useful if the embedded system has to operate in night or low light conditions.

In this application the camera was configured to operate with a resolution of 320x240 pixels (QVGA size) with 16 bits/pixel in the RGB565 image format (5 bits for the R color, 6 for the G, and 5 for the B). This format requires 150 Kbytes of memory to store one color image so, if needed; the complete image can be stored in the internal MCU SRAM memory (196 Kbytes).

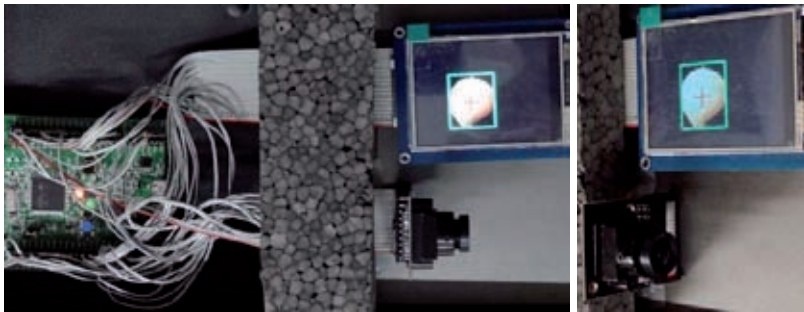

Fig. 1. Two images of the processor board, color camera module, and auxiliary LCD screen module.

### 3. Results

The embedded vision system has been used to detect and track individual fruit pieces (red peaches) either in synthetic laboratory indoor and real outdoor conditions. The main differences between both conditions were the controlled artificial and uncontrolled illumination that affects largely the detection process. Fig. 2 shows an example unprocessed color image acquired by the camera plotted in the auxiliary LCD. The image shows a red peach surrounded by green leaves. Fig. 3 shows a color image profile of the transition between both objects. Fig. 3 also evidences the higher dynamic range (smaller

incremental steps) of the G color (coded with 6 bits) relative to the R and B colors (coded with 5 bits). Fig. 1 also shows the results of the fruit segmentation obtained when applying the following color intensity conditions:  $R > 100$  &  $R > G$ . In Fig. 1 the red cross marks the centroid of the peach object and the green line delimitates its bounding box.

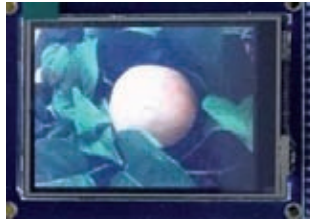

Fig. 2. Example image acquired by the embedded vision system.

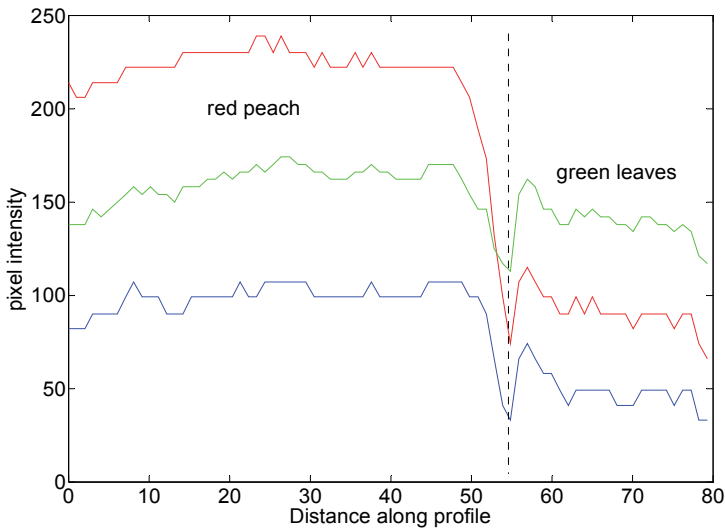

Fig. 3. Image color profile of a transition between one red peach and green leaves.

The determination of the color space, color intensity, and color conditions that must be used to segment a fruit or fruits in the images acquired by the camera depends largely on the fruit skin color profile and the illumination conditions. In the tests performed, the segmentation and location of a red peach in one



QVGA image required 62 ms in average, so the vision system will be able to visually correct the position of a robotized arm around 15 times per second with a total power consumption of 1.05 W (with the LCD plugged). The results of the different tests performed with red peaches have validated and confirmed the utility of this proposed embedded system in an application that require real-time fruit detection and tracking.

#### 4. Conclusions

A proposed embedded vision system has been used to detect and track individual red peaches in indoor and outdoor conditions, although it can be used for other fruit harvesting. The results of the different tests performed have validated the utility of this proposal in an automatic harvesting application that requires real-time fruit detection and tracking performances.

#### Acknowledgements

*This work was partially funded by the University of Lleida, Indra, the Government of Catalonia (Comisionat per a Universitats i Recerca, Departament d'Innovació, Universitats i Empresa) and the European Social Found.*

#### References

- Anderson, J.D., D.J. Lee, B. Edwards, J. Archibald, C.R. Greco (2007). Real-Time Feature Tracking on an Embedded Vision Sensor for Small Vision-guided Unmanned Vehicle. *International Symposium on Computational Intelligence in Robotics and Automation*, 55-60.
- Belchair, A.N., M. Litzenberger, C. Posch, P. Schon (2007). Real-Time Vision Using a Smart Sensor System. *IEEE International Symposium on Industrial Electronics*, 1968-1973.
- Jimenez, A.R., R. Ceres, J.L. Pons (2000). A survey of computer vision methods for locating fruit on trees. *Transactions of the ASAE*, 43, 1191-1920.
- Litzenberger, M., C. Posch, D. Bauer, A.N. Belbachir, P. Schön, B. Kohn, H. Garn (2006). Embedded vision system for real-time object tracking using an asynchronous transient vision sensor. *IEEE Digital Signal Processing Workshop*, 173-178.
- Liu, Y., B. Chen, J. Qiao (2011). Development of a Machine Vision Algorithm for Recognition of Peach Fruit in a Natural Scene. *ASAE Paper*, 54(2), 695-702.
- Pla, F., F. Fuste, F. Ferri, M. Vicens (1993). Colour segmentation based on a light reflection model to locate citrus fruit for robotic harvesting. *Computers and Electronics in Agriculture*, 9, 53-70.
- Plebe, A., G. Grasso (2001). Localization of spherical fruits for robotic harvesting. *Machine vision and applications*, 13, 70-79.
- Wachs, J.P., H.I. Stern, T. Burks, V. Alchanatis (2010). A low and high-level visual feature-based apple detection from multi-modal images. *Precision Agriculture*, 11, 717-735.
- Zhao, D., J. Lv, W. Ji, Y. Zhang, Y. Chen (2011). Design and control of an apple harvesting robot. *Biosystems Engineering*, 110(2), 112-122.





## Topic 2.3 ICT technologies in precision agriculture







**First RHEA International Conference on  
Robotics and associated High-technologies  
and Equipment for Agriculture**  
Hosted by the University of Pisa  
Pisa, Italy, September 19-20-21, 2012



Exploring the effect of turning manoeuvres on the multi-path planning of a robot fleet in agricultural tasks

Jesus Conesa-Munoz<sup>1</sup>, Angela Ribeiro<sup>1</sup>, Dionisio Andujar<sup>2</sup>, Cesar Fernandez-Quintanilla<sup>2</sup>, Jose Dorado<sup>2</sup>

<sup>1</sup>Centre for Automation and Robotics (CSIC-UPM). 28500, Arganda del Rey, Madrid, Spain (e-mail: [jesus.conesa@csic.es](mailto:jesus.conesa@csic.es), [angela.ribeiro@csic.es](mailto:angela.ribeiro@csic.es))

<sup>2</sup>Institute of Agricultural Science (CSIC).28006 Madrid, Spain

**Keywords:** Multi-objective optimization, Weed control, NSGA-II.

---

**Abstract:** In the context of robot fleets, one of the main problems consists in determining the best routes (multi-path plan) for the robots to minimise some cost criterion when robots accomplish a given task. For example, in a weed treatment scenario the multi-path plan must ensure a fully completed treatment, i.e., the whole field coverage, as inexpensive as possible. The cost can be expressed by a function that considers the most relevant features of each robot in the fleet, for example, in a weed spraying treatment, the tank capacity, the number of turns required or the time spent in the whole treatment. The robot turning maneuvers directly affect the travelled distance and, therefore, the time spent in the treatment task; special attention is focused on them.. In consequence, real types of turns have been considered in order to obtain realistic results, focusing especially on the limitations that appear due to the restrictions in the turning radio that the agricultural vehicles usually have. The Non-dominated Sorting Genetic Algorithm II (NSGA-II) is proposed to solve this multi-objective optimization problem. The proposed approach has been proved with good results in multiple situations dealing with different fields and diverse robot features. The obtained results show that it is possible to find good solutions for the different criteria considered (i.e., time and money) at the same time.





## 1. Introduction

Agriculture is one of the contexts where robot automation is applicable and may become relevant in the near future. Many agricultural operations could be performed by either a single robot or a fleet of them. Weed treatment is one of these operations and one of the most important and critical tasks in crop fields. In this task, weeds are frequently removed by sprayers carried onboard by vehicles that must cover the whole field without overlaps. This task requires substantial attention by the driver. It is such an important and complex operation that commercial guidance systems based on GPS have recently been developed to help tractor drivers. Furthermore, many studies have been aimed at determining the best way to treat a crop by covering a given area (field) trying to minimize the distance travelled by a vehicle (Closet and Pignon 1997; Stoll 2003; Sorensen et al., 2004; Taix et al, 2006; Oksanen and Visela 2007; Bochtis and Vougioukas 2008)

This problem becomes even more complex when more than one vehicle is involved in the task. In (Conesa-Munoz et al., 2012) the problem is tackled as a multi-objective optimisation that involves two different cost functions in order to determine the multi-path plan with the lowest cost. The cost functions are based on time and money criteria that take into account the vehicle/robot capabilities but assuming always an ideal situation in which vehicles/robots do not have limitations on the turning manoeuvres, so they can reach in the same way any point in the field.

In this article, however, the different types of turning manoeuvres defined in (Bochtis and Vougioukas 2008) (Fig. 1) have been considered, since these manoeuvres strongly affect the path plan quality.

## 2. Proposed approach

The fields considered in this work are split into parallel crop rows, therefore, five assumptions can be made to appropriately handle the multi-path plan problem: 1) robots always travel



parallel to the crop rows, 2) changes in the moving direction (turns) of the robots are forbidden within the crop rows and can only be made in the headers (out of the crop), 3) the fields have rectangular shapes, 4) the weed distribution (locations of the weed patches) is known, and 5) when a robot totally consumes its herbicide during the treatment of a row, it has to reach a header to refill its herbicide tank and then turn back to finish treating the row.



Fig. 1. Manoeuvres in the headland turns (a) loop turn, (b) double round corner.

According to these assumptions, the problem can be expressed as follows: given a set of robots with certain features (e.g., herbicide capacity, motion characteristics, width of the treatment sprayer, fuel and herbicide consumption), a field with certain dimensions, a crop organised in rows and a map of the weed distribution, the aim is to determine the subset of robots and their associated path plans that ensure the full treatment of the weeds with the minimum cost in terms of both time and money.

In other words, given a set of valid field operations (*start*, *motion*, *turn* or *spraying*), the weed treatment accomplished by a robot can be expressed by a vector  $(a_1, a_2, \dots, a_m)$ , where  $m$  is the number of different operations considered, and  $a_i$  is the number of times that the robot has executed the operation  $i$ . Each one of these operations can be measured in time and money, thus, for each multi-path plan assigned to a specific fleet of robots, two costs can be computed according to expressions (1).

$$f_c(X) = \sum_{i=1}^n \sum_{j=1}^m c_{ij}^c \cdot a_{ij} \quad f_t(X) = \max_{i=1}^n \sum_{j=1}^m c_{ij}^t \cdot a_{ij} \quad (1)$$



where  $n$  is the number of robots,  $m$  is the number of possible operations,  $a_{ij}$  is the number of times that the robot  $i$  executes the operation  $j$  (*start, motion, turn* or *spraying*), and  $c_{ij}^e$  and  $c_{ij}^t$  are, respectively, the costs in money and in time spent by robot  $i$  to execute operation  $j$ . In (Conesa-Munoz et al., 2012) it is explained in detail how to compute the partial costs  $c_{ij}^e$  and  $c_{ij}^t$ .

### 2.1 NSGA-II scheme

As we have seen in the previous section, the multi-path plan problem has been formulated as bi-objective optimization problem. Hence, it requires a solving process that optimizes simultaneously the two objectives, as for example the “pareto optimization” strategy used by NSGA-II (Non-dominated Sorting Genetic Algorithm II, Deb et al., 2002) also incorporated in our proposal. Five components have to be defined when a NSGA method is used: the solution encoding scheme, the exploration operators (selection, crossover and mutation), and the fitness function.

Hereinafter, the set of crop rows that the vehicle treats at the same time will be named “street”. According to the assumptions 1, 2 and 5, each street will only be treated by a robot of the fleet, so each possible multi-path plan can be expressed as a permutation of the vector:  $(s_1, s_2, \dots, s_n, r_1, r_2, \dots, r_m)$ .

The robot identifiers ( $r_j$ ) are used to delimitate the sets of streets in such way that each robot covers the streets located in the left of its identifier. For example the vector  $(s_1, s_2, r_2, s_3, r_1, s_4)$  represents a plan where robot 1 will only treat street  $s_3$  and robot 2 will cover streets  $s_4, s_1$  and  $s_2$ , in this order because the treatment order of the streets is set by the order of the vector components. Obviously, the transition distances between streets are calculated considering the turning manoeuvres.

Concerning exploration operators, a classical wheel selection, a PMX crossover and a scramble mutation have been chosen. The selected crossover and the mutation operators are appropriated

for building permutations. Finally, the fitness functions are shown in (1).

### 3. Experimental results and analysis

A set of 100 randomly generated trials was conducted to measure the mean fitness obtained by the proposed approach. The main parameters used have been the following: in all cases, the population size was set to 100 individuals and the fleet was composed of 5 robots with a minimum turning radius of 3 m. The fields contain 400 streets and the level of infestation ranged from 10% to 30%; in addition the number of patches ranged from 10 to 80. The stop criterion was set to complete 50,000 generations. For each one of these trials the best plan in money, the best plan in time and also the best plan for both criteria at the same time were extracted and their fitness values normalized between 0 and 1, where 0 is the best value for the fitness functions  $f_e(x)$  and  $f_t(x)$  that have been adapted to perform the turning manoeuvres proposed by (Bochtis and Vougioukas, 2008).

The mean fitness values for the money and the time obtained were 0.147 and 0.026 respectively. When both criteria are considered, the fitness value was 0.153. All results are quite close to the optimal values calculated analytically, especially in the case of time. Actually, it is easier to find a good solution in time than in money, because there are much more good solutions for time than for money in the search space. In practice, any solution where the number of streets is equally distributed among the robots shows a good performance in time. For the money, it is not so easy to find good solutions. Nevertheless, it has been observed that the *pareto* fronts have barely been expanded, so with more than 50,000 generations better results might be obtained. This matter has to be deep analyzed in future work.

### 4. Conclusions

Efficient and economical weed treatment with a robot fleet requires obtaining the best path plan for each vehicle in terms of



either money or time spent in the task. To obtain realistic path plans it is needed to consider the turning manoeuvres into paths. In this paper the multi-path planning problem is formulated as a bi-objective optimization problem and then an approach based in a pareto strategy (NSGA-II) is used for solving the problem. Results obtained from 100 simulations show mean fitness values for money, time and both criteria combined of 0.147, 0.026 and 0.153 respectively. All of these values are very close to the optimal values estimated analytically. Therefore, the proposed method is able to find the multi-path plan for a heterogeneous fleet of vehicles even taking into account restrictions due to the minimum turning radius of vehicles.

### Acknowledgements

*The Spanish Government and the European Union have provided full and continuing support for this research work through projects: PLAN NACIONAL - AGL2011 - 30442 - C02 - 02 (GroW) and UE - CP - IP245986 - 2(RHEA).*

### References

- Stoll, A. (2003) *Automatic operation planning for GPS-guided machinery*. Proceedings 4<sup>th</sup> European Conference on Precision Agriculture, Berlin, edited by J.V. Stafford & A. Werner, pp. 657-664, 2003.
- Taix, M., Souères, P., Frayssinet, H. and Cordesses, L. (2006). Path Planning for Complete Coverage with Agricultural Machines Field and Service Robotics. *Springer Tracts in Advanced Robotics*, 24, 549-558.
- Oksanen, T. and Visala, A. (2007) Path Planning Algorithms for Agricultural Machines. *Agricultural Engineering International: the CIGR Ejournal*, 9.
- Choset, H. and Pignon, P. (1997) *Coverage Path Planning: The Boustrophedon Decomposition*. Proceedings of the FSR'97: International Conference on Field and Service Robotics.
- Sørensen, C.G., Bak, T. and Jørgensen, R.N. (2004) *Mission Planner for Agricultural Robotics* AgEng 2004, Leuven, Belgium, 12-16 September 2004. Abstract in Book of Abstracts, p. 894-895.
- Bochtis, D.D. and Vougioukas, S.G. (2008) Minimising the Non-working Distance Travelled by Machines Operating in a Headland Field Pattern. *Biosystems Engineering*, 101, 1, 1-12.
- Deb, K. Pratap, A., Agarwal, S. and Meyarivan, T. (2002) A fast and elitist multiobjective genetic algorithm: NSGA-II. *IEEE Transactions on Evolutionary Computation*, 6, 2, 182-197.
- Conesa-Munoz, J., Ribeiro, A., Andujar, D., Fernandez-Quintanilla, C. and Dorado, J. (2012) *MultiPath Planning Based on a NSGA-II for a Fleet of Robots to Work on Agricultural Tasks*. Proceedings of IEEE CEC Conference. Brisbane, Australia.
- Eiben, A.E. and Smith, J.E. (2003) *Introduction to Evolutionary Computing*, Springer, ISBN 3-540-40184-9



**First RHEA International Conference on  
Robotics and associated High-technologies  
and Equipment for Agriculture**  
Hosted by the University of Pisa  
Pisa, Italy, September 19-20-21, 2012



Topic 2.3: ICT technologies in precision agriculture

**ICT based Innovative Farmer Education Programme to  
bridge Information and Knowledge gap of Agriculture: A  
Case Study in Sri Lanka**

Nisansala P. Vidanapathirana<sup>1</sup>, Kshanika Hirimburegama<sup>2</sup>,  
W.K. Hirimburegama<sup>2</sup>, Jae Ho Kim<sup>2</sup> and  
Sriwarnasinghe A.P. Nelka<sup>2</sup>

<sup>1,2</sup> *University of Colombo, Institute for Agro-technology and Rural Sciences,  
Sri Lanka (nisansalavp@yahoo.com, hirimk@pts.cmb.ac.lk,  
whirim.user@gmail.com, jhkrda47@gmail.com, gayanelka@gmail.com)*

**Keywords:** ICT based Farmer education, socio-economic status,  
information and knowledge gap

---

**Abstract:** Sri Lankan farmers face constraints in gaining access to information and knowledge that could improve their crop productivity and there is a huge knowledge and information gap between agricultural experts and farmer. To bridge this gap University of Colombo Institute for Agro-technology and Rural Sciences, Sri Lanka has built the Online Diploma in Agro-technology for farming community both in local language and English, which is an ICT-based agricultural education system to improve productivity, income and socio- economic status by disseminating a fresh expert agricultural advice to farmers. Agricultural experts generate lessons received in the form of text and digitally converted lessons developed on online Learning Management System in Moodle. In 2009, a prototype was implemented with 60 farmers all around the country. The impact of the program for improvement of their knowledge (in ICT, agriculture) and socio-economic status was analyzed. At the beginning of the course they had no competency with computer usage and ICT applications even some of them never had touched a computer before taking up the program. After the program their ICT compatibility and knowledge of farming have increased. The analysis showed that about 80% of farmers have followed program which increases yield, income and social status.



## 1. Introduction

Today, Information and Communication Technology (ICT) is developing rapidly in all over the world. Information is the lifeblood of organization. It's vital to collect accurate and complete information for all market sectors and industries including agriculture (Thompson and Sonka, 1997). ICT offers the ability to increase the amount of information provided to all participants in the agricultural sector and to decrease the cost of disseminating the information (Kurtenbach and Thompson, 2000). There is an urgent need to increase access to information and the Internet and these facilities be made available to the general masses mainly the rural folks including farmers in Sri Lanka.

Many projects on ICT based education have been done, but rarely have been done on rural farmers by enhancing the state-of-art digital technologies to serve the rural farmers and upgrade the economy of the country. In fact distance and e-learning environment can be used widely either for educational or training but the problem which still exists is the efficient and effective management and application of the contents and its effectiveness to the users especially the rural farmers. One has to be prepared for the computer literacy and the other thing which has to be looked into is the language, learning culture and acceptance purposes (Shirley and Alstete, 2001). Elsinger (2000) and Young (2001) suggested that within the web-enabled environment, individuals can have access to courses on individual topics and performance support resources at anytime from anywhere. On the other hand, Lalita (1996) also noted that effective, cost-efficient instruction that can match the needs for skills related to technological change can be delivered interactively, at the convenience of the rural farmers as the learner, no matter where their physical location would be.

Being an agricultural country with fertile soil and good climate for agriculture plus many natural resources, Sri Lanka has a vast potential for agricultural development. It has a population of a little more than 19 million people. About 70% lives in the rural sector, where agriculture is the main source of income.

Agricultural production in the rural sector is much lower than its potential. Farmers face constraints in gaining access to information and knowledge that could improve their livelihoods and maximize crop productivity. Therefore, new and innovative approaches are needed to cope with these challenges.

The ICT-based agricultural education system developed by this research is to improve productivity, income and socio-economic status of farmers in Sri Lanka by disseminating a fresh expert agricultural advice. This program is the first ever attempt by a University in the country to provide an opportunity for the rural farming community to pursue further education. This pioneer project has proven its worth as the foundation of modern mode of education delivery system in Sri Lankan farmers. The program acts as a platform for educating the rural farmers through open and distance learning by managing the blended learning management system. Furthermore, this is another step in the introducing of lifelong learning concept to all in Sri Lanka not only increasing the productivity, competitiveness and value added which will enable the rural society to enjoy the advancement of digital technology for everyday living and realizing Sri Lanka as a developed nation in future.

The objectives of the study are, to determine the readiness of the rural farmers' acceptance on ICT learning tool for getting knowledge and information for improving their livelihoods and to determine the improvement of farmers' knowledge and socio-economic status after following the program.

## **2. Materials and methods**

The online Diploma in Agro-technology program consists of eight Certificate Courses on diverse agriculture subjects. Learning Management system (LMS) was developed in local language using Moodle and online discussion forums and chat sessions were also designed to discuss their day-to-day issues in agriculture with their colleagues and teachers. Learner support is provided through learner guides, CDs and DVDs, computer assisted instruction and video-conferencing in local language. To encourage peer interactions, online learning groups based on





agriculture interest of student farmers have been facilitated. Farmer students were facilitated to access the courses through any one of the National Online Distance Education Service Access Centers (NACs) and the Government ICT centers located throughout the country.

### *2.1. Data collection and analyzing*

Randomly selected fifty student farmers who are following the course were investigated. Results were analyzed using statistical methods (Percentile and Wilcoxon Signed-Rank Test). Student farmers were asked whether they have any change in knowledge, income, entrepreneurship, marketing ability, social mobilization, and agri-business creation after following the course by using questionnaires, discussions and participatory observations.

## 3. Results and discussion

### *3.1. Farmer student's performances with the program*

Through the Diploma it was possible to reach the people who have never dreamt of education through online modes. The ongoing Online Diploma Program is a success to emulate. At the beginning of the course, 44% of them were very poor in computer usage, 65% had no idea of internet and 70% did not have e-mail accounts. Therefore, the very first activity was to give them an orientation on IT and internet usage. The ICT was rapidly accepted by the students. At present 86 % of them are competent in computer usage, 97% of them are able to use internet without any difficulty, all of them have e-mail accounts (Figure 1).

### *3.2. Socio-economic improvements*

With this program most of them (85%) have improved their cultivations and most of them have started new agribusinesses. Income of most farmer students (57%) generated from agriculture was poor and not sufficient before following the course. After the program, majority of their income (65%) was increased up to level of good (Figure 2). Motivations towards the job and job satisfaction of farmer students both have significant improvement.

Their social contacts with agricultural and non-agricultural institutions and persons have been strengthened while gaining the benefit of their services (Figure 3). Main reason for this is that they became more aware of the importance of those contacts for their personal and professional development. Therefore, farmers tended to use more the services of those organizations or institutes after the program.

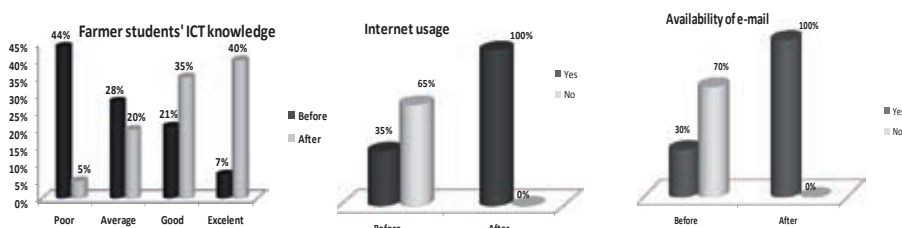

Fig.1. Farmer student's performances with the program

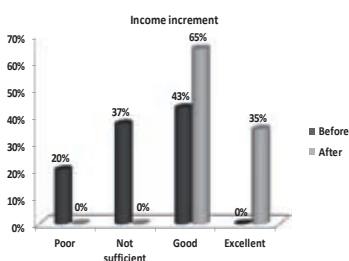

Fig.2. Income increment

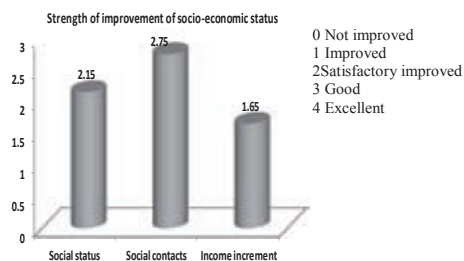

Fig.3. Strength of improvement of socio-economic status

### *3.3. Key challenges faced while implementing the program*

One of the key challenges faced is the heterogeneity of farmers such as age, schoolings and majority of them did not have computer skills. Therefore, it was a big challenge to introduce ICT for people who never touch the computer. Orientation course for ICT and strengthen learner support starting from the beginning was succeeded to avoid this. Also majority of them were able to learn only with local language. Therefore, Learning Management System (LMS) and lesson contents were developed in local language and also in English. When starting the course lack of connectivity in remote areas was a big challenge for giving access to the course. For this Ministry of Higher



Education has established NODES (National On-line Distance Education Service) Access Centres in every district with all ICT infrastructures. Farmers can access the lessons through any one of the centers located in all districts.

#### 4. Conclusion

In conclusion we can say that the use of ICT offers opportunities to meet the increasing demand for education of farmers, agriculture experts and others who are involved in agriculture to meet the present and future challenges of agricultural development. A general lesson from the initiative that employs ICT for agricultural development is that successes are possible, but that program must be designed and implemented with care. Success is not derived automatically from inserting ICT into isolated, poor communities.

Several future trends of great importance are: Converging of media and tools for communication, Increased web-based storage of agricultural information, Cheaper and improved connectivity for rural communities and Increased recognition by governments of the importance of the use of ICT in rural development. Finally we can conclude that the On-line distance learning is a suitable method for farmers to learn. This is a new and modern opportunity for younger generation who lack of knowledge on agriculture and has special interest on agriculture. Also, this course is considered to farmer students as a way of keeping themselves with satisfaction and pride towards the agriculture as their profession.

#### References

- Elsinger (2000) *Key Elements of Effective On-line Education in Rosemary Wild, Kenneth Griggs and Tanya Downing, 2002 A Framework for E-Learning as a Tool for Knowledge Management*. Industrial management and Data System, 102(7), 371-380.
- Kurtenbach, T. and Thompson, S. (2000) *Information Technology Adoption: Implications for Agriculture*. Available at, [https://www.ifama.org/conferences/9/1999/1999%20Congress/Forum%20PapersProceedings/Kurtenbach\\_Tammy.PDF](https://www.ifama.org/conferences/9/1999/1999%20Congress/Forum%20PapersProceedings/Kurtenbach_Tammy.PDF).
- Lalita, R. (1996), *The Virtual Class: The Emerging Educational Paradigm*. Educomp 1996, 2-12.
- Shirley and Alstete (2001) *Knowledge and Information Management in e Learning Environment; The User Agent Architecture*. Information Management and Computer Security, 10(4), 165-170.
- Thompson, S. and Sonka, S.T. (1997) *Potential Effects of Information Technologies on the Economic Performance of Agricultural and Food Markets*. American Journal of Agricultural Economics, 657-662.
- Young, K. (2001) *The Effective Development of e Learning*. Industrial and Commercial Training, 33(1), 5-11.



**TOPIC n° 2.3 ICT technologies in precision agriculture**

**User interactions with robotic fleets for intelligent  
agriculture**

**Domagoj Drenjanac<sup>1</sup>, Slobodanka Tomic<sup>1</sup>**

<sup>1</sup> *The Telecommunications Research Center Vienna (FTW), Donau-City Strasse 1,  
Vienna, Austria, e-mail: [drenjanac,tomic]@ftw.at*

**Keywords:** User interfaces, Robotic fleet, Decision support

---

**Abstract:** This paper reviews challenges in user-fleet interaction approaches, with an emphasis on different applications of networked robotic fleets and the enabling technologies. The purpose of human-robot interaction (HRI) technology is in the short-term to facilitate efficient automation of processes and in the long-term to enable operation of teams in which humans and robots jointly perform complex tasks and missions. Humans can interact with robots in different roles, including a mission planner, a remote operator, an in-field operator for maintenance and diagnosis tasks, or a close collaborator in joint missions. In this paper different approaches to human-robot interactions are first examined and then put in the context of interactions in precision agriculture focusing on the scenario of the robotic fleet for weed control addressed within the European Project RHEA-*Robot Fleets for Highly Effective Agriculture and Forestry Management*.

---

## **1. Introduction**

Networked robotic fleets are used within a wide range of applications: from space and surveillance tasks in demanding physical environments, to complex emergency search and rescue missions (Casper, Murphy, 2003), to agricultural and forestry precision management (Conesa-Muñoz, Ribeiro, 2011). While robotic fleets are designed for limited autonomous operation in the field and interaction with humans for the operation purposes, some robotic fleets occupy working or living environments and



directly serve humans, or interact with humans in joint tasks. Specific application requires certain capabilities of the HRI. The most challenging future scenario is the one in which humans and autonomous robots with self-optimizing and learning capabilities collaborate in joint tasks.

Operating a robotic fleet is a cognitively demanding task that requires efficient user-fleet interface for decision-support in control and monitoring, diagnosis, problem detection and resolution, complementing the autonomous decision making that the robotic fleet units are capable of. The role of the human-operator needs to be carefully defined for applications of robotic fleets in open and uncontrolled environments.

The paper is structured as follows. Section 2 provides a brief review of human-fleet interaction concepts. Section 3 focuses on the HRI of the RHEA system. Section 4 concludes the paper.

## **2. Human-fleet interactions**

A networked robotic fleet consists of multiple robots with potentially heterogeneous capability jointly performing some mission (Kumar et al., 2008). In the networked robotic fleets communication is the basic enabler for HRI. Humans may interact with the fleet in different roles (remote supervision and operation, maintenance, joint work) depending on the robotic task but also on the level of robots' autonomy. Adaptive autonomy is the term used to refer to autonomy of robotic units designed for flexible change, i.e., the autonomy may increase or decrease depending on the state of the system, environment and requirements of the human operator (Goodrich et al., 2007).

Important requirements for HRI tools are to avoid ambiguities in remote perception, to see into future team activities, contingencies and responsibilities of team members, and to observe robots reasoning processes (Woods et al., 2004). For these tasks data presentation methods are of critical importance for users enabling them to make right decisions at the right moment based on the presented data.

The existing work further identify challenges in designing multi-human multi-robot interaction mechanisms in relation to

scalability (Tews et al, 2003) and coordination (Fazli, Mackworth, 2009). Coordination challenges are shown to be related to task/role allocation, coalition formation, communication constraints, heterogeneity, safety and reliability, ability to measure and predict human and robot performance, robustness and tolerance to faults. The safety of human interactions with robots becomes a key issue as robots move into the human, interactive and uncertain environments

Adopting the team based coordination approach (Kirsch et al, 2010) proposes a plan-based control of joint activities. This includes collaborative planning, human aware navigation essential for safety in approaching humans and avoiding humans and joint manipulation.

### **3. Human-robot interactions for the RHEA robotic fleet**

The state of the art robotic fleet management in the RHEA project pushes the limits of a modern precision agriculture towards complete automation of an agricultural process (Gonzalez-de-Santos et al., 2011). To guarantee impeccable accomplishment of high mission standards the autonomous control is combined with complementary human interaction.

The RHEA project addresses all fundamental challenges for robotics: perception for unstructured environments, safety for operation near humans, HRI, and networks of robots, sensors and users. The RHEA robotic fleet is composed of ground mobile units (GMU) with agricultural implements for precision weed or forestry treatment. The human operators interact with the RHEA system in two roles: the remote operator at the base station and the operator in the field. The RHEA applies a robotic fleet in an outdoor human environment which makes safety the crucial issue. Safety is addressed with the design of various detection mechanisms on the robots, forming the three groups of safety measures related to the subject of the risk imposed by an uncontrolled robot: the human, other robots, and the environment. First group focuses on avoiding possible collisions or application of chemicals in the vicinity of humans. The second includes methods for avoiding collision among mobile



robots. The third presents safety procedures for mitigating the negative impact on the surroundings.

To efficiently combine autonomous control embodied within the robots and in the decision making system, the system exposes relevant data and control interfaces for human intervention. Base station is equipped with a multiple big screens for user interfaces while in the field a robust and portable user interface device offers just a relatively small touch-screen. To avoid information overload, the RHEA approach is to systematically present hierarchically organized filtered and aggregated data to the operator. Software running on the user portable device further enables the operator to manually take the control of robots in order to prevent possible risks and damage. To avoid misuse, each attempt of taking a control over a robot in the field is authorized by the central mission management system running at the base station. The user is not able to pause or abort the whole mission, rather influence the behaviour of a certain robot. Shrinking the complete set of functions deployed on the base station, limits the user direct intervention to field related tasks.

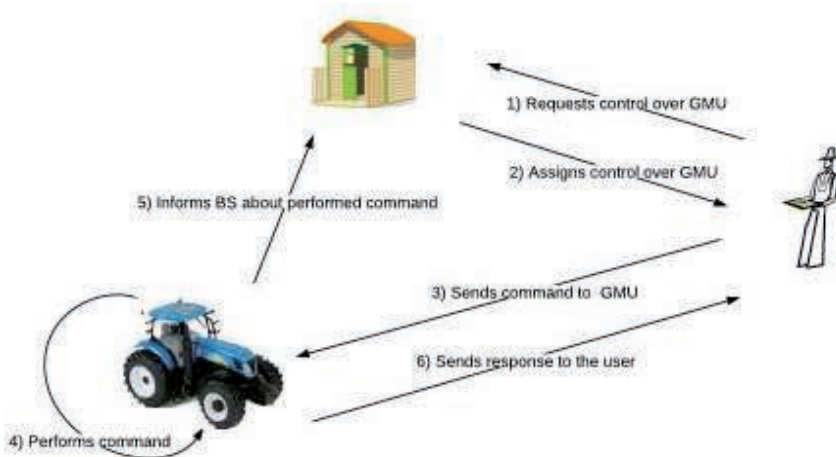

Fig 1. User interaction with RHEA robots

Figure 1 illustrates a general HRI scenario in RHEA between the operator in the field and the robotic fleet. In order to interact with the robotic fleet, the operator in a field issues a command



that may be a controlling command, or a status command. Controlling commands influence the status of the GMU by changing the speed, steering, or influencing behaviour of the implement. Status commands are used to retrieve the status of GMU such as the current position, speed, heading, or the status of the implement. The sequence of commands presented on the Figure 1 is the same for every type of an issued command.

The number of operators that may cooperate in the system drives additional HRI requirements. In RHEA there may be just one operator in the system acting at different times in different spaces based on the status of the fleet: for example the mission planning and control is a remote operation task performed from the base station; only in case of need for on-the-spot diagnoses and problem resolution the user acts in the field.

In RHEA, the software deployed at the user portable device facilitates an operator in directly controlling the ground mobile unit, by the direct robot manipulation, e.g. steering, start, stop, acceleration, deceleration so the robot may be brought in the best position for continuation of the mission according to the operator opinion. Flexible RHEA fleet management allows selection of an arbitrary (optimal) fleet size. This requires scalable concept for data presentation at the user interfaces (primarily at the base station) but also scalability and reliability of the communication system which serves as fleet communication backbone.

#### **4. Conclusions**

Interaction between humans and robotic fleets in different application fields ranges from operation to teaming in joint tasks. In the precision agriculture the interactions among humans and autonomous robotic fleet predominantly focus on interactions for a fleet operation, including in-field interactions. To detect safety critical situations robots are equipped with systems for person or animal detection, ground mobile unit detection, static obstacle detection and off-track detection. To cover all possible situations of HRI, the high-level decision making system in RHEA is distributed among the base station



and the user portable devices. These redundant decision-making systems with human interactions facilitate prevention of hazardous situations and efficient in-field missions.

### Acknowledgements

*This paper is supported within the European Research Project RHEA. The Telecommunication Research Center Vienna (FTW) is supported by the Austrian government and the City of Vienna within the competence center program COMET.*

### References

- Woods, D.D, Tittle, J. Feil, M., Roesler, A (2004) *Envisioning human-robot coordination in future operations, Systems, Man, and Cybernetics, Part C: Applications and Reviews*, IEEE Transactions, vol.34, no.2, pp.210-218.
- Casper, J.; Murphy, R.R. (2003) *Human-robot interactions during the robot-assisted urban search and rescue response at the World Trade Center," Systems, Man, and Cybernetics, Part B: Cybernetics*, IEEE Transactions on , vol.33, no.3, pp. 367- 385.
- Conesa-Muñoz,J., Ribeiro, A. (2011) *An evolutionary approach to obtain the optimal distribution of a robot fleet for weed control in arable crops*. Proceedings of the 8th EFITA/WCCA. Prague, CZ, 11-14 July 2011
- Fazli, P., Mackworth, A.K. (2009) *Human-Robot Teams in Entertainment and Other Everyday Scenarios*, In Proceedings of the International Conference on ACE, ACE 2009, Athens, Greece, October 29-31.
- Gonzalez-de-Santos, P., Vieri, M., Ribeiro, A., Raffaelli, M., Emmi, L., Fontanelli, M., Rimediotti, M., Frasconi, C., Sarri, D., Peruzzi, A. (2011) *The RHEA project: a fleet of autonomous robots for precision chemical and non chemical weed management in arable crops and on-canopy spraying in tree crops*. Convegno di Medio Termine dell'Associazione Italiana di Ingegneria Agraria, Belgirate, 22-24
- Goodrich, M.A., McLain, T.W., Anderson, J.D., Sun J., Crandall, W. (2007) *Managing autonomy in robot teams: observations from four experiments*. In Proceedings of the ACM/IEEE international conference on Human-robot interaction (HRI '07).
- Kirsch, A., Kruse, T., Sisbot, E.A., Alami, R., Lawitzky, M., Brščić, D., Hirche, S., Basili, P., Glasauer, S., (2010) *Plan-Based Control of Joint Human-Robot Activities*, KI - KÜNSTLICHE INTELLIGENZ, Volume 24, Number 3.
- Kumar, V, Rus D. Sukhatme, G.S. (2008) *Networked Robots, Chapter in Springer Handbook of Robotics*, Editor: Siciliano, B., Khatib, O., 2008, Springer Berlin Heidelberg, 943-958.
- Tews, A., Mataric, M.J., Sukhatme, G.S. (2003) *A scalable approach to human-robot interaction*. IEEE International Conference on Robotics and Automation, ICRA 2003: 1665-1670.



First RHEA International Conference on  
Robotics and associated High-technologies  
and Equipment for Agriculture  
Hosted by the University of Pisa  
Pisa, Italy, September 19-20-21, 2012



**TOPIC n° 2.3: ICT technologies in precision agriculture**

### **Self-Organizing Multi-Technology Communication for Agriculture Robotic Fleets**

**Thomas Hinterhofer<sup>1</sup>, Slobodanka Tomic<sup>1</sup>**

<sup>1</sup> *FTW Telecommunications Research Center, Donau-City-Straße 1/3, A-1220 Vienna, Austria, (e-mail: [hinterhofer,tomic]@ftw.at)*

**Keywords:** Robotics, Multi-Technology Communication, Resilience, Desynchronization, TDMA

---

**Abstract:** In this work we present a wireless multi-technology communication system designed for an agriculture robotic fleet. Our approach addresses the requirements of reliable communication: data has to be delivered in time and service disruptions have to be minimized, despite changing wireless channel conditions caused by interference and fast fading. We show how both problems can be handled effectively by simultaneously using multiple off-the-shelf communication technologies. In particular, IEEE 802.11a, IEEE 802.11g and IEEE 802.15.4 are used, which have distinct physical layers and operation frequencies. Furthermore, we propose a multi-technology management approach to handle these technologies. It is based on a self-organizing distributed time division multiple access (TDMA) negotiation on top of standard carrier sense multiple access with collision avoidance (CSMA-CA). Our approach prevents two nodes from transmitting at the same time and maximizes communication robustness and predictability. In addition, the system continuously gathers information about the multi-technology network topology. This information is used to detect and predict communication issues, so that technology management decisions of each node can be based on the awareness of the network status. Finally, we present details of how these concepts will be implemented on an embedded Linux platform.



## 1. Introduction

The usage of robotic fleets in precision agriculture aims at making crop and weed management more efficient and environmentally sustainable. Robust wireless communication is one important enabler for precision agriculture: as they move within the field, the robots in a fleet exchange real-time control and status information with a central control system, or also among themselves. Their joint mission critically depends on how timely and reliably the information is transported. In the RHEA European project, an agriculture robotic fleet is controlled from a central base station in charge of mission planning and supervision. The mission control and monitoring applications have specific requirements regarding the reliable and timely delivery of data even in case of interference and fast fading effects (Sklar, 1997). The latter one can be improved by the usage of multiple communication technologies with heterogeneous physical layers. Interference caused by nodes using the same communication technology is often resolved with carrier sense multiple access with collision avoidance (CSMA-CA) techniques. Nevertheless, the random selection of backoff times introduces unpredictable transmission delays especially at high traffic loads (Ziouva and Antonakopoulos, 2002). One possibility to overcome this problem is the usage of time division multiple access (TDMA). TDMA avoids collisions and enables timely delivery of data. There are numerous ways to establish a TDMA schedule (Rhee et al., 2009; Wang et al., 2006; Demirkol et al., 2006). One key differentiator is whether the schedule is defined centrally or in a distributed way.

The rest of the paper is organized as follows: The next section introduces the desynchronization principle and our distributed TDMA negotiation approach, which is resilient to arbitrary transient packet loss. Section 3 presents approaches for multi-technology management and how our TDMA algorithm supports these management decisions. Afterwards, we show our implementation on an embedded Linux platform in Section 4. Finally, Section 5 presents configuration, management and diagnosis functions before we conclude the paper in Section 6.

## 2. Resilient Dynamic Desynchronization (RD<sup>2</sup>)

In the distributed desynchronization algorithm DESYNC (Degeys et al., 2007; Degeys and Nagpal, 2008), every participating node  $i$  periodically broadcasts a beacon  $B_i$  with a period of  $T$ . This period is equal to the length of one desynchronization round. The beacons are used to establish desynchronization. As depicted in Fig. 1, every node  $i$  transmits one beacon  $B_i^r$  in every round  $r$ . In addition, it listens to the beacons of the nodes sending immediately before and after him:  $B_{i-1}^r$  and  $B_{i+1}^r$ . In the following round  $r+1$ , node  $i$  will send its beacon  $B_i^{r+1}$  in the middle of the expected transmission times of  $B_{i-1}^{r+1}$  and  $B_{i+1}^{r+1}$ . TDMA time slots of equal size can then be easily defined based on these beacons. In contrast to DESYNC, our Resilient Dynamic Desynchronization (RD<sup>2</sup>) guarantees a non-overlapping TDMA schedule even in the presence of arbitrary transient packet loss. The communication topology has to be fully connected and the maximum transmission delay and clock drift have to be known and bounded. In addition, RD<sup>2</sup> enables every node to dynamically request its time slot size. As a consequence, desynchronization is not based on beacon times, but on the slot end of the previous node and the slot start of the next node (c.f. Fig. 1).

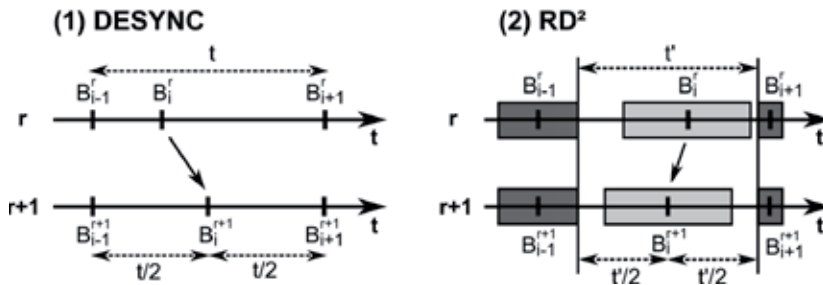

Fig. 1. Comparison between DESYNC and RD<sup>2</sup>

In RHEA, we run RD<sup>2</sup> on top of standard off-the-shelf hardware for wireless communication. The used 802.11 and 802.15.4 technologies are based on CSMA-CA MAC techniques (Tien-Shin and Kwang-Cheng, 1996). While carrier sensing will always be performed, contention windows can be configured aggressively as we do not expect collisions. Nevertheless, the



underlying CSMA-CA helps in particular during system start-up and to be resilient to interference caused by other nodes operating in the same frequency range.

### 3. Multi-Technology Management

The availability of multiple communication technologies results in the need of an appropriate management. Vertical handover based approaches select the technology most suitable for the actual communication requirements. RD<sup>2</sup> can be used to pre-allocate the TDMA time slot before handover is performed. If one technology cannot fulfil the requirements, a simultaneous usage is necessary. Traffic is partitioned and redirected to different interfaces. RD<sup>2</sup> enables fast and easy redirection as TDMA time slot sizes can be dynamically changed within a small number of rounds. The simultaneous usage of multiple technologies is also necessary for time critical traffic if time redundancy (retransmissions) is not possible. According packets can be transmitted on multiple technologies to increase the probability of a successful and timely delivery.

### 4. Implementation

The architecture of the RHEA communication system is depicted in Fig. 2.

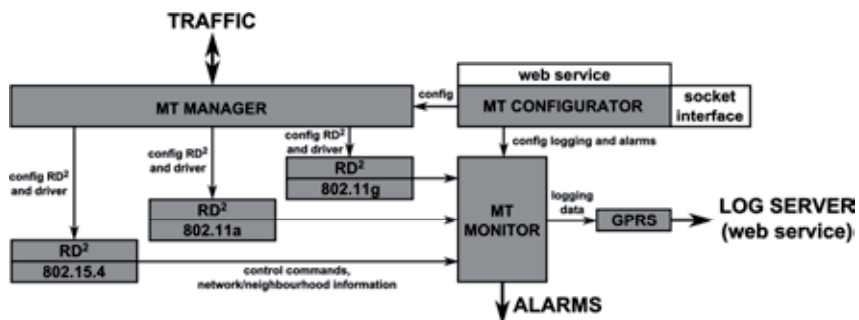

Fig. 2. Architecture of the RHEA communication system

The **Resilient Dynamic Desynchronization (RD<sup>2</sup>)** algorithm is used in every device driver on top of 802.15.4, 802.11a and 802.11g MAC. Outgoing traffic is buffered and sent in the allocated time slot. RD<sup>2</sup> automatically adjusts the time slot size to empty the buffer and to minimize transmission delays. The

**Multi-Technology (MT) Manager** configures RD<sup>2</sup>, CSMA-CA parameters and the physical layer. Furthermore, it selects the appropriate technology or partitions the traffic coming from upper layers. The **Multi-Technology Monitor** monitors the robotic application traffic and continuously gathers network topology and neighbourhood information, which is broadcasted in RD<sup>2</sup> beacons. The logging data is transmitted via GPRS to a remote logging server. More details on the communication performance monitoring and prediction can be found in Hinterhofer and Tomic (2011). The **Multi-Technology Configurator** configures the MT manager and the MT monitor. Configuration can be done remotely by using a web service or using a socket interface.

## **5. RHEA Communication Scenario**

The most important parameter to be configured is the RD<sup>2</sup> desynchronization period  $T$ . It depends on the requirements of the application regarding transmission times. If packets have to be delivered within a time  $t_d$ , the round period  $T$  has to be equal or smaller than  $t_d$ . In this case a node will be able to transmit packets in its TDMA time slot before the deadline expires if an empty RD<sup>2</sup> buffer is assumed. In RHEA, the robotic control is the most critical traffic. It consists of commands with small payload but strict timing constraints. As the 802.15.4 technology has the highest transmission range and the device driver is of least complexity, it is used to transmit the RHEA control traffic. Only if the RD<sup>2</sup> algorithm on top of 802.15.4 detects that the communication requirements cannot be met, the multi-technology manager routes the traffic over an 802.11 technology. Normally, traffic with higher requirements regarding throughput (e.g. video streams) is routed over these 802.11 technologies. The mission supervisor can observe the status of the communication system by accessing the logging web service, which graphically displays the network topology with corresponding link parameters (signal strength, transmission delay, error rates and throughput). In case of serious communication issues, the MT monitor creates alarms automatically and delivers them to a configurable destination.





## 6. Results and Conclusions

We presented a multi-technology management approach based on our self-organizing TDMA negotiation algorithm (Resilient Dynamic Desynchronization RD<sup>2</sup>). It works on top of CSMA-CA of off-the-shelf hardware and reliably avoids collisions caused by nodes transmitting at the same point in time. RD<sup>2</sup> is also used to continuously broadcast network information. Consequently, every node is aware of the multi-technology network health, which is used by the management and supervision functions. Furthermore, we presented the architecture of a Linux-based implementation on an embedded platform. Configuration and supervision features are remotely accessible. Finally, we gave an example of how the multi-technology communication approach in terms of configuration, operation, supervision and alarming is used.

## Acknowledgements

*This paper is supported within the European Research Project RHEA. The Telecommunications Research Center Vienna (FTW) is supported by the Austrian government and the City of Vienna within the competence center program COMET.*

## References

- Sklar, B. (1997) *Rayleigh fading channels in mobile digital communication systems. I. Characterization*. Communications Magazine, IEEE, vol.35, no.7, pp.90-100, Jul 1997
- Ziouva, E. and Antonakopoulos, T. (2002) *Csma/ca performance under high traffic conditions: throughput and delay analysis*. Computer Communications, vol. 25, no. 3, pp. 313-321
- Rhee, I., Warrier, A., Min, J. and Xu, L. (2009) *DRAND: Distributed Randomized TDMA Scheduling for Wireless Ad Hoc Networks*. Mobile Computing, IEEE Transactions on, vol.8, no.10, pp.1384-1396, Oct. 2009
- Wang, W., Wang, Y., Li, X., Song, W. and Frieder, O. (2006) *Efficient interference-aware TDMA link scheduling for static wireless networks*. 12th annual international conference on Mobile computing and networking (MobiCom). ACM, New York, NY, USA, 262-273.
- Demirkol, I., Ersoy, C. and Alagoz, F. (2006) *MAC protocols for wireless sensor networks: a survey*. Communications Magazine, IEEE, vol. 44, pp. 115-121, April 2006
- Degeys, J., Rose, I., Patel, A. and Nagpal, R. (2007) *Desync: Self-organizing desynchronization and tdma on wireless sensor networks*. 6<sup>th</sup> International Symposium on Information Processing in Sensor Networks (IPSN), pp. 11-20.
- Degeys, J. and Nagpal, R. (2008) *Towards desynchronization of multi-hop topologies*. Second IEEE International Conference on Self-Adaptive and Self-Organizing Systems. pp. 129-138.
- Tien-Shin, H. and Kwang-Cheng, C. (1996) *Performance analysis of IEEE 802.11 CSMA/CA medium access control protocol*. Seventh IEEE International Symposium on Personal, Indoor and Mobile Radio Communications (PIMRC), vol. 2, pp. 407-411
- Hinterhofer, T. and Tomic, S. (2011) *Wireless QoS-enabled Multi-Technology Communication for the RHEA Robotic Fleet*. First International Workshop on Robotics and Associated High-Technologies and Equipment for Agriculture (RHEA), pp. 173-186



TOPIC n° 2.3

### **WEEDEX: a weed expert system for a robot fleet in agriculture**

**Cesar Fernandez-Quintanilla<sup>1</sup>, Jose Dorado<sup>1</sup>, Jose Conesa-Muñoz<sup>2</sup>, Angela Ribeiro<sup>2</sup>**

<sup>1</sup> Instituto de Ciencias Agrarias, CSIC, Serrano 115, 28006 Madrid, Spain ([cesar@ica.csic.es](mailto:cesar@ica.csic.es))

<sup>2</sup> Centro de Automática y Robótica, UPM-CSIC, Crtra. Campo Real Km 0,2, 28500 Arganda del Rey, Madrid, Spain ([angela.ribeiro@csic.es](mailto:angela.ribeiro@csic.es))

**Keywords:** Decision Support Systems, Robotics, Herbicide treatments, Spatial information

---

**Abstract:** The objective of this work is to provide the basic specifications for the design of a robotic weeding decision support system based on spatio-temporal information on weed infestations. The WEEDEX system operates based on six modules: 1) *Time Planning*, 2) *Weed Threat Assesment*, 3) *Herbicide Options*, 4) *Path Planning*, 5) *Herbicide Application* and 6) *Supervision*. The aim of this system is to generate georeferenced prescription maps indicating the sites where each herbicide should be sprayed. These maps should provide the information required to purchase the herbicides and to decide the optimal distribution of the spraying units of the robot fleet and their corresponding navigation plans. Final spraying decisions should be based on both, prescription maps and online information coming from sensors located in the sprayer.

---

## **1. Introduction**

During the last two decades a large number of Decision Support Systems (DSS) have been developed trying to improve various aspects of weed control (e.g. Nesser et al., 2004; Parsons et al., 2009). Recently, Berti et al. (2010) conducted a review of nine



DSS developed in different European countries, analyzing the opportunities for integration of selected parts of these systems. The aim of this work was using the best parts of each system in terms of 'building blocks' of a new DSS capable to reduce herbicide use while maintaining an adequate level of weed control.

Although all these 'building blocks' provide valuable components for the construction of a robust DSS some components are still lacking. One of them is the spatial and temporal aspects of weed control. It is well documented that weed infestations may be quite variable in time and space, with patches of different weed species infesting the fields at different times of the year. The management of this heterogeneity offers an excellent opportunity to reduce herbicide use. However, up to now, farmers have not being able to manage this variability due to the lack of adequate tools to monitor weed infestations, to take control decisions and to conduct these decisions site-specifically.

The advent of new technological tools has opened new opportunities in this regard. Aerial inspection of the fields using unmanned aerial vehicles (ULV) may allow a periodic monitoring of weed populations present in the field (Lopez Granados, 2011). Spatial information on weed infestation may be managed by DSS specifically focused to take into account this variability (Gutjahr & Gerhards, 2010). Different types of sensors may detect weed presence and, in some cases, discriminate different weed types on real time (Weis & Sokefeld, 2010). Spatially variable herbicide application technology has been devised to conduct patch spraying (Christensen et al., 2009). Robotic weed control systems hold promise toward the automation of these operations and provides another tool for reducing herbicide use (Slaughter et al., 2008).

The objective of this paper is to provide the basic specifications for the design of a weed expert system for robotic agriculture (WEEDEX).

## **2. Materials and methods**

The outline structure of WEEDEX is based on the conceptual approaches and on some of the specifications proposed previously by Berti et al. (2010) and Fernandez-Quintanilla et al. (2011). The system operates based on six modules:

### ***2.1. Time Planning***

This module is designed to support the correct timing of various actions related with chemical weed control. This tool is partially based on algorithms which relate time of emergence (and subsequent growth stages) of the crop and the weeds to the time of sowing and actual weather conditions recorded thereafter. Time is managed as thermal time accumulated in 10-days periods. This information is used to decide early weed inspection and herbicide application times. Decisions to be made later on the season (e.g. herbicide effect, infestation at harvest) are made on a fixed schedule. Herbicide purchase decisions are made on a relatively wide time window.

### ***2.2. Weed Threat Assessment***

This module is designed to quantify the potential threat from the major weed species that are expected in a given field. It includes two components: 1) the intrinsic harmfulness of each species, and 2) the risk of infestation of that species.

The intrinsic harmfulness of each species is derived from empirical information obtained in field experiments and from experience from experts. This component is considered as uniform in all the field.

The risk of infestation of each species is site-specific. The information on the spatial distribution of each weed species is initially based on the weed infestation map obtained at harvest in the previous season. This map is composed of individual cells of the same size that the planned spraying resolution (e.g. 3 m x 3 m). Considering that low densities of weeds are probably missed in the aerial inspection, that weed infestation at harvest only shows the central core of weed patches, and that areas that



were not adequately controlled in the previous season may spread due to tillage or harvest operations, buffer areas are included in the harvest weed infestation map.

### ***2.3. Herbicide Options***

This module is designed to estimate the total amount of different herbicides that will be required in a given season based on the information available from the previous season. This estimate is used, primarily, to purchase suitable assortments and quantities of herbicides in adequate time before the growing season. This module includes three components: 1) selection of herbicides and doses, 2) construction of draft prescription maps, and 3) estimate of total quantities required.

The selection of herbicides to be used is based on the list of major weeds recorded in the previous season, the list of available herbicides for that crop, the specific performance of each of these products, and various agronomic and economic conditions. The lists of weeds and herbicides are crossed using a herbicide efficacy table.

In order to control grasses and broadleaved weeds independently, two weed classes are considered. This module is designed to select one herbicide of each type, trying to optimize efficacy and cost and taking into account other additional criteria (e.g. risks of resistance). The construction of draft prescription maps is made independently for the two weed classes defined previously.

In order to estimate of total quantities of the two herbicides required it is necessary to integrate the number of cells of each risk class and each weed class and the doses of herbicides to be applied to those cells.

### ***2.4. Path Planning***

Given a set of robots with certain features (e.g., herbicide capacity, motion characteristics, width of the treatment bar, fuel and herbicide consumption), a field with known dimensions, a crop organized in rows and a map of the weed distribution, the

aim of this module is to determine the subset of robots and their associated path plans that ensure the full treatment of the weeds with the least cost in terms of both time and money. This multi-path planning problem can be considered a multi-objective optimization and has been tackled using a Non-dominated Sorting Genetic Algorithm (NSGA) strategy.

### ***2.5. Herbicide Application.***

The early-season map is constructed from aerial images obtained a few days before spraying. Considering that aerial images are not able to provide very precise information on weed coverage, only three classes are established: High cover, Medium cover and Low cover.

The intrinsic harmfulness of each weed species is calculated as described in module 2.2.

The competitive situation derives from the sum of the difference between the growth stage of the crop and the weeds and a variable indicating the quality of the crop canopy.

Based on all the information previously described, the herbicide prescription map for each weed class is constructed. The herbicide products to be used were selected in module 2.3.

Although the prescription map provides basic information of the field areas that should be sprayed, this information needs to be contrasted with that obtained at spraying time with cameras or sensors that detect weed presence and quantify weed cover. Once the detected weed patch has been considered as a suitable target for spraying, a fast-response controller will regulate discharge of the different herbicides in each individual nozzle.

### ***2.6. Supervision***

In order to assess the effect of herbicide treatments, a ground inspection is expected to be done one week after spraying. Unmanned ground vehicles equipped with appropriate sensors will move through the field, sampling the photosynthetic activity of surviving weeds. The results of this assessment will determine



decisions on subsequent control actions. Aerial scouting using ULV will be conducted at weed flowering time in order to assess residual populations.

### **Acknowledgements**

*The European Union has provided support for this research through project UE - CP - IP245986 -2(RHEA).*

### **References**

- Berti, A., R. Masin, N. Munier-Jolain, O.Q. Boejer, and P. Rydahl. (2010). *Specifications for design of a unified, European, generic DSS for weed control*. In: ENDURE Deliverable DI2.7 “Report on crop x pest systems and specification for technical and organizational requirements for construction and test of operational DSSs that integer some ‘best parts’ of existing DSS. 11-50
- Christensen, S., H.T. Sogaard, P. Kudsk, M. Norremark, I. Lund, E.S. Nadimi and R. Jorgensen. (2009). Site-specific weed control technologies. *Weed Research* 49, 233-241
- Fernandez-Quintanilla C, J. Dorado, C. San Martin, J Conesa-Muñoz and A Ribeiro. (2011). A five-step approach for planning a robotic site-specific weed management program for winter wheat. In: *RHEA-2011. Robotics and associated high-technologies and equipment for agriculture*. Ed. by P. Gonzalez-de-Santos & G. Rabatel. pp. 3-12
- Gutjahr, C. and R. Gerhards. (2010). Decision rules for site-specific weed management. In: *Precision crop protection-The challenge and use of heterogeneity*. Ed. by E-C. Oerke, R. Gerhards, G. Menz & R. Sikora. Springer. pp. 223-239
- Lopez-Granados, F. (2011). Weed detection for site-specific weed management: mapping and real-time approaches. *Weed Research* 51, 1-11
- Nesser, C., J.A. Dille, G. Krishnan, et al. (2004). Weed SOFT: a weed management decision support system. *Weed Science* 52, 115-122
- Parsons, D.J., L.R. Benjamin, J. Clarke, D. Ginsburg, A. Mayes, A.E. Milne and D.J. Wilkinson (2009). Weed Manager-A model-based decision support system for weed management in arable crops. *Computers and Electronics in Agriculture*, 65, 155-167.
- Slaughter, D.C., D.K. Giles and D. Downey. (2008). Autonomous robotic weed control systems: A review. *Computers and Electronics in Agriculture* 61, 63-78
- Weis M & M. Sokefeld. (2010). Detection and identification of weeds. In: *Precision crop protection-The challenge and use of heterogeneity*. Ed. by E-C. Oerke, R. Gerhards, G. Menz & R. Sikora. Springer. pp. 119-133





ISBN-13: 978-88-6741-021-7



9 788867 410217