



**HAL**  
open science

## Change of forage practices and technical dialogues among beef cattle farmers in Burgundy

Claude Compagnone, Sylvie Granger, Christophe-Toussaint Soulard

► **To cite this version:**

Claude Compagnone, Sylvie Granger, Christophe-Toussaint Soulard. Change of forage practices and technical dialogues among beef cattle farmers in Burgundy. 14. Symposium on Permanent and temporary grassland: plant, environment and economy (EGF 2007), Sep 2007, Gent, Belgium. hal-02754440

**HAL Id: hal-02754440**

**<https://hal.inrae.fr/hal-02754440>**

Submitted on 3 Jun 2020

**HAL** is a multi-disciplinary open access archive for the deposit and dissemination of scientific research documents, whether they are published or not. The documents may come from teaching and research institutions in France or abroad, or from public or private research centers.

L'archive ouverte pluridisciplinaire **HAL**, est destinée au dépôt et à la diffusion de documents scientifiques de niveau recherche, publiés ou non, émanant des établissements d'enseignement et de recherche français ou étrangers, des laboratoires publics ou privés.



# **Permanent and Temporary Grassland Plant, Environment and Economy**

*Edited by*

**A. De Vliegher  
L. Carlier**



**VOLUME 12  
GRASSLAND SCIENCE IN EUROPE**

## Foreword

Grassland as a whole and especially natural grassland covers a big part of the European territory. In some countries with large mountain areas, permanent grassland covers more than half of the land used for agricultural purposes. However, sometimes it is not very clear what is meant by the term permanent pasture in comparison with temporary grassland. The European Commission defines permanent pasture as “*land used to grow grasses or other herbaceous forage naturally (self seeded) or through cultivation (sown) and that has not been included in the crop rotation of the holding for five years or longer*” (Commission Regulation (EC) No 796/2004). This already gives us, as grassland researchers matter for reflection and conversation.

In easily convertible soils (e.g. Flanders, the Netherlands, UK, Denmark, Germany, West-France) with a moderate climate farmers are used to renovating their grassland regularly and incorporating it in their farm production scheme. Sometimes grassland -for grazing conditions during summer time- and maize -growing for winter stable feeding- are the only crops on dairy or beef production farms.

Permanent pastures with a good botanical composition have the advantage to permanently cover the soil with a positive effect on production, C storage, capturing minerals and nitrate nitrogen, erosion prevention... On the other hand regularly renovated grassland and temporary grassland gives the opportunity to introduce the newest developed varieties of good and well adapted grass species on the farm. Breeding always creates new varieties with specific characteristics for a better production and/or quality, an improved resistance against diseases, biotic and abiotic stress e.g. frost, draught, ...

Do we have to pay special attention to our grassland in the next decades because of ‘global warming’? Will softer and wetter winters combined with drier and hotter summers constraint the production capacity of grassland and how will grassland compete with other forages?

The proceedings of this symposium contain 133 papers and all the abstracts of papers and posters are summarized in a special booklet. We will overlook the item of the symposium in three sessions. During the mid conference tours the participants get some information on Flemish grassland farming and during the post conference tours we will pay special attention to the more natural grassland in the Walloon Provinces.

We would like to seize the opportunity to thank numerous people for their help in the organisation of this symposium and the publishing of this book: the members of the Organizing and Scientific Committees, the external reviewers, etc.

We wish all of you a nice stay in Gent and a fruitful participation to this 14<sup>th</sup> international symposium of the EGF at the headquarters of the Faculty of Bioscience Engineering of Gent University.

Lucien Carlier  
President of the organizing committee

Alex De Vliegher  
Secretary of the organizing committee

# Opening Session

# The comparison between temporary and permanent grassland

Reheul D.<sup>1</sup>, De Vliegher A.<sup>2</sup>, Bommelé L.<sup>1</sup> and Carlier L.<sup>2</sup>

<sup>1</sup> *University of Gent, Department of Plant Production, Coupure links 653, BE-9000 Gent*

<sup>2</sup> *ILVO, Plant Crop Husbandry and Environment, Burg. Van Gansberghelaan 109 box 1, BE-9820 Merelbeke, Belgium*

## Abstract

An overview is given of definitions and importance of temporary and permanent grassland in Europe. Problems and opportunities of temporary grassland in comparison with permanent grassland are summarised for seed mixtures, dry matter yield, clover content and residual soil nitrogen.

A good sward should never be turned down. If old swards are to be turned down the best option is to start an arable period with the establishment of N greedy crops. If new swards are necessary the best option is to establish them in arable land. If swards really need to be re-established the application of a cutting regime prevents potential N leaching.

## 1. Introduction

When Sir Richard Weston travelled from England to Belgium in 1644 he went from one surprise to the next. In his “Discours of husbandrie used in Babant and Flanders”, edited in 1650 he gives his impression on the quality of the land and its management between Dunkerque (now France) and Antwerpen. Between Dunkerque and Brugge he saw a prosperous wealthy land, covered with wheat, barley and meadows. Half way between Brugge and Gent, he noticed, the quality of the land became poorer. Seen from the main roads between Gent and Antwerpen he saw very poor heathland, reminding him on his own land back in England. In Gent he met a Dutch merchant who told him that farmers living in the “poor” land between Gent and Antwerp were by far the richest farmers of Flanders. Weston thought the Dutchman was joking, but he was not. Another Dutchman introduced and brought him to some succesful farmers where he found out the origin of the wealth. The Flemish farmers applied a specific crop rotation when exploiting the heathland. As a first crop they grew flax, immediately followed by turnips. The next year they installed oats, undersown with grass-clover which they kept for up to five years. The clover was very likely red clover but after five years evolution it was replaced spontaneously by white clover. With this crop rotation the farmers earned more money<sup>1</sup> than those growing cereals and meadows on the fertile sandy loam soils between Dunkerque and Brugge.

## 2. Definition of temporary and permanent grassland

In the EU **permanent grassland** is defined as follows: land used to grow grasses or other herbaceous forage naturally (self-seeded) or through cultivation (sown) and that is not included in the crop rotation of the holding for five years or longer (Commission Regulation EU No 796/2004). Before the EU definition, permanent grassland was defined in vague terms. It was an area with grass as a continuous crop for a relatively long to very long time, with or without resowing. The EU needed a clear and simple definition of permanent grassland in the

---

<sup>1</sup> At that time an acre of barley had a value of 10-12 pounds, an acre of wheat 5-6 pounds, an acre of flax 40-50 pounds, an acre of grass-clover 10-12 pounds and an acre of turnips 8-10 pounds.

framework of their subsidization policy but for some farmers it feels strange to call grassland “permanent” when it is only 5 years of age. In official statistics about agriculture, the area of permanent grassland is restricted to the area which is used for grazing and/or cutting, even when the management is very extensive.

A **ley** is an area of land where grass is grown temporarily instead of crops (Oxford Dictionary). **Temporary grassland** is a typical crop in the Atlantic part of Europa and in southern Scandinavia. The EU definition of temporary grassland is grassland less than 5 years of age, included in a crop rotation.

Before the EU definition, temporary grassland was defined as “sown grassland included in a crop rotation”. Depending on the country, it lasted for a very short time or for a longer period (Table 1). In Denmark this type of grassland is managed for about 2-4 years and in Ireland for at least 4 years but usually for a much longer period.

In the Mediterranean area the term ‘temporary’ grassland is not in use but replaced by ‘artificial’ grassland containing wheat/ barley or some grasses due to be grazed during 1 or 2 seasons respectively.

### **3. Facts and figures on temporary and permanent grassland in Europe**

Approximately half of the European Union’s land is farmed, highlighting the importance of agriculture in the society. Utilised agricultural area (UAA) in EU is defined as the area taken by arable land, permanent grassland, permanent crops (e.g. vineyards) and kitchen gardens. Permanent grassland covers 32% of the UAA with important differences between the member states (Table 2). France, UK and Spain have over 7 million of hectares of permanent grassland. In the UK, Ireland and Slovenia permanent grassland covers at least 60% of the UAA.

Eurostat and many national statistics allocate temporary grassland (<5 years) to arable land. There is no overview of the temporary grassland area available in Eurostat. Denmark is the only EU member state where temporary grassland covers a larger area than permanent grassland (Table 1). In other member states no more than 10-20% of the grassland is temporary. It is negligible in mediterranean member states as Greece, Cyprus and Malta.

According to the new EU regulations, national areas of permanent grassland should be preserved on farm level. Should a farm turn down some of its grassland, it is compulsory to install a new area of an equal surface, to be managed as grassland for at least 5 years.

As a consequence farmers try to limit their area of permanent grassland 1) because they fear a devaluation of value for land covered with grass and 2) because the higher the permanent grassland area, the lower the land use flexibility. Newly installed grassland is ploughed down before it gets the status of permanent grassland, i.e. before it reaches 5 years of age, irrespective of the quality of the sward.

The species used in temporary grassland strongly depend on the life span of the grassland. If the grassland is used for no more than 2 years, usually Italian ryegrass (*Lolium multiflorum* Lam.) and hybrid ryegrass (*Lolium x hybridum* Hausskn.) are used. In some cases these species are combined with red clover. If the ley is lasting for a longer period, perennial grasses, combined with white clover or lucerne are preferred as indicated in Table 1.

#### 4. Why farmers renovate their grassland?

Farmers turn down a grass sward when it becomes unproductive or when its quality declines. The main reason for the decline in yield and quality is the botanical deterioration of the sward as a consequence of the introgression of inferior grasses and herbs.

The introgression occurs upon gap formation and gaps are formed due to abiotic and biotic reasons as:

- severe frost, drought and flooding
- impermeable soil layers and soil compaction due to passages of heavy machinery or animal trampling during wet periods
- inaccurate application of organic and mineral fertilizers
- heavy cuts and inaccurate stocking density
- damage by vertebrates and invertebrates or by fungal diseases

Thresholds to consider swards as inferior differ in member states as mentioned in Conijn *et al.* (2002) represented in Table 3. The insufficient presence and importance of perennial ryegrass and too high a presence of couch (*Elytrigia repens* (L.) Desv ex Nevski) and docks (*Rumex spp.* L.) are the main reasons to plough down a grass sward.

Methods of grassland renovation are well described by Andries *et al.* (1983), Carlier (1988), Carlier *et al.* (1998) and Conijn *et al.* (2002).

A standard procedure for grassland renovation:

- Spraying to kill the old sward with total herbicides e.g. glyphosate when the sward contains couch grass is recommended
- Destruction of the old sward with rotary cutter, followed by ploughing to a depth of 20-25 cm
- Seed bed preparation in such a way that there is a loose soil layer of approximately 2-3 cm on top of a firm soil.

Direct seeding into the old sward is only recommended when the soil does not allow tillage like in heavy clay, peat or shallow soils, containing a lot of stones. De Vlieghe *et al.* (1986) found the results of direct drilling in a sward, killed with total herbicides, in many cases very disappointing.

In ley-arable farming, the grassland is temporary and apart from the forage production an important function is to improve soil fertility during the arable period. Organic farming is depending heavily on a ley-arable farming system and the area of short term grass-white clover (*Trifolium repens* L.) swards is expected to grow in parallel with the rise of organic farming

Table 1. Definition and characterisation of temporary grassland in European countries

Country	Relative share P/T <sup>(1)</sup>	Year <sup>(3)</sup>	Definition permanent and temporary grassland	Species in temporary grassland	Source
Norway	82/18 <sup>(2)</sup>	1999	P 1. grassland not renovated in 10 years (official definition) 2. grassland were sown species has disappeared		Nesheim - pers. comm.
Denmark	30/70	2005	P minimum 5 years (EU subsidization-rule) T 2-4 years followed by arable crops	ryegrasses and white clover	Soegaard <i>et al.</i> - 2002 Soegaard - pers. comm.
Netherlands	90/10	2000	T <6 years followed by arable crops	mainly ryegrasses	Schiltz <i>et al.</i> - 2002
Belgium	86/14	2006	T short term grass followed by arable crops	Italian and hybrid ryegrass	Anonymus 1986,
Ireland	-		T minimum 4 years grassland in rotation with arable crops	perennial ryegrass + white clover	Humphreys <i>et al.</i> 2002
UK	83/17	2003		ryegrasses	Hatch <i>et al.</i> 2002
France	79/21	2000	T 1 to 6 years before 2004, than 1-4 years (EU)		Pfimlin <i>et al.</i> -2003
Germany	81/19	2002	P > 10 years before 2004, than minimum 5 years T 1-4 years	ryegrasses, <i>Festuca</i> species (+ legumes)	Taube <i>et al.</i> 2002 Elsaesser - pers. comm.
Switzerland	-		P > 6 years used for grazing and/or cutting T 'Kunstwiese' grass included in the crop rotation for at least one year	grass mixturs with legumes	Walter - pers. commun.
Poland	90/10	2003	P >12-16 years before 2004; really permanent but now resown every 5-6 years	<i>Trifolium pratense</i> L. and <i>Medicago sativa</i> L. sometimes in combination with <i>Dactylis glomerata</i> L., ryegrasses, <i>Phleum pratense</i> L. and <i>Festuca pratensis</i> L.	Stipinski - pers. comm.
Hungary	-		T 2-4 years as a part of arable land registration system makes no difference between P and T, grass is not used in arable rotations		Nagy - pers. comm.
Greece	-		P natural grassland + shrub land + open forest T artificial = mainly wheat or barley for grazing, pasture species for grazing one or more years		Papanastasis and Karacosta - pers. comm.

<sup>(1)</sup>: P is permanent and T is temporary grassland<sup>(2)</sup>: on land possible to plough<sup>(3)</sup>:year in which relative shares are reported



Table 2. Permanent Grassland in the EU, 2005

Country	Permanent grassland area			
	1000 ha	% of total area	% of Utilised Agricultural Area	
EU-25	51652	13	32	
EU-15	43668	14	34	
Ireland	IE	3016	43	72
Slovenia	SI	304	15	60
United Kingdom	UK	8885	36	60
Austria	AT	1811	22	56
Luxembourg	LU	68	26	52
Netherlands	NL	777	21	40
Portugal	PT	1507	16	40
Belgium	BE	519	17	37
Latvia	LV	627	10	36
France	FR	9939	18	34
Lithuania	LT	888	14	31
Italy	IT	4399	15	30
Germany	DE	4927	14	29
Spain	ES	7270	14	28
Estonia	EE	231	5	28
Slovak Republic	SK	525	11	27
Czech Republic	CZ	844	11	24
Poland	PL	3377	11	21
Hungary	HU	1061	11	18
Sweden	SE	314	1	10
Denmark	DK	220	5	8
Finland	FI	34	0	1
Cyprus	CY	1	0	1
Greece	EL	0	0	0
Malta	MT	0	0	0

Source: Eurostat, Agricultural Products - land use and structure of agricultural holdings European Communities, 2007

Table 3. Definition of inferiority of a grass sward in EU member states. Taken from Conijn *et al.* (2002).

Member State	A sward is inferior if
Belgium	>15% <i>Elytrigia repens</i> (Er)
Ireland	<40% <i>Lolium perenne</i> (Lp) >30% unwanted species >20% bare patches
The Netherlands	>15% <i>Rumex obtusifolius</i> L. <50% Lp >10% Er

## 5. Problems and opportunities of temporary grassland and the comparison with permanent grassland

### 5.1 Introduction

Compared to permanent grassland, temporary grassland has two key critical points: (1) the end of the grassland period when the sward is turned down and (2) the establishment of the new sward.

The mineralization of a turned down grass sward produces a lot of nitrogen. This mineralized nitrogen offers the opportunity to save fertilizer nitrogen and hence to cut costs and environmental loads going along with the production of mineral nitrogen. But it takes a greedy crop and a well balanced cropping sequence in order to prevent nitrogen leaching.

In a ley arable system, temporary grassland is established in arable land. From an agronomic point of view, the best period to establish new grassland is during early autumn: weed incidence is less than during spring time and the new grassland takes full advantage of the growing peak during spring time in the next growing season. In intensive farming systems based on grassland and forage maize, the establishment of new grassland during autumn is not always possible because forage maize leaves the land too late. An alternative is to re-establish grassland in turned down (temporary) grassland.

*What is the best option to install temporary grassland and does temporary grassland offer advantages compared to permanent grassland?*

At the University of Gent we compared the performance of permanent grassland with the performance of temporary grassland installed either in arable land or in grassland. Both the arable and grassland period were either long (36 years) or short (3 years). We studied DM yield, the evolution of the clover content, the mineralisation and the nitrogen use by the new grassland.

In this text following abbreviations are used to indicate previous crops: A: arable land; G: grassland; T: temporary; P: permanent. The undisturbed permanent grassland (established in 1966) is indicated as PGG. All previous grassland was grazed.

New swards were installed with a 1:1 mixture (on weight basis) of two varieties of perennial ryegrass (*Lolium perenne* L.) cv 'Roy' and cv 'Plenty' and the white clover (*Trifolium repens* L.) cv 'Huia' during spring 2002. 'Roy' is an intermediate heading tetraploid variety, 'Plenty' is a late heading diploid variety. Perennial ryegrass was sown at 40 kg ha<sup>-1</sup>, white clover at 4 kg ha<sup>-1</sup>.

Main species in the PGG sward were perennial ryegrass, rough meadowgrass (*Poa trivialis* L.) and white clover with importance percentages of 37, 17 and 10% respectively.

The experimental design was a split plot design with 4 replicates. Swards were managed under a cutting regime, simulating a grazing regime. Yearly nitrogen fertilization was 0, 100, 300 and 400 kg ha<sup>-1</sup>.

Material and methods are described in detail in the PhD thesis of Lydia Bommel  (2007): Growing potatoes and grass-clover after turned down grassland.

## 5.2 Dry matter yield

Table 4 shows the performance of the grass-clover swards. Excluding the year of establishment following conclusions can be drawn for the periode 2003-2005 and averaged over the 4 nitrogen dressings.

1. Arable land is a better previous crop than grassland.
2. Permanent arable land is significantly the best option.
3. The new temporary grassland installed in permanent arable land, outyielded PGG by 19%. This high difference was mainly due to the very poor performance of PGG during the very dry summer of 2003: at 0 N and 100 N a yield penalty of 46 % in PGG was recorded.
4. The higher the nitrogen application, the smaller the differences.

It is well know that newly established grassland has a deeper rooting pattern than old grassland; this advantage becomes clear during dry periods under a low nitrogen management.

The superior performance of young grassland during 2003 was confirmed in a trial at ILVO, where young swards were compared with a reference sward established in 1996. Swards were re-established in the autumn of 1997, 1998, 1999 and 2000. All swards were grazed; the pure grass swards were dressed with 300 kg ha<sup>-1</sup> N, the grass-white clover swards with 150 kg ha<sup>-1</sup> N. The grass swards established in 2000, 1999 and 1998 outyielded the reference sward but differences were not significant, but the grass-clover sward established in 2000 outyielded the reference significantly (Table 5). The swards re-established in 1999, 1998 and 1997 yielded significantly less than the reference in 2003. Details about this trial are given in De Vliegheer and Carlier (2007) in this volume.

Table 4. Dry matter yield (kg DM ha<sup>-1</sup>) of newly established grass-clover swards related to previous land use (PLU) and mineral N fertilization (N). Period 2002-2005. Cutting regime: simulated grazing management

Previous land use	Mineral N fertilization	Year				Mean	Mean
		2002	2003	2004	2005	2002-2005	2003-2005
PA	0	7981	12997	10980	13193	11288	12390
	100	10204	14925	11618	12339	12271	12961
	300	11717	14917	16057	14387	14270	15120
	400	13323	15035	18742	16493	15898	16757
	Mean	10806	14469	14349	14103	13432	14307
	Relative <sup>c</sup>	80	108	107	105	100	107
TA	0	8175	11909	11222	11514	10705	11548
	100	8903	11985	11867	11322	11019	11725
	300	11504	13321	15481	15378	13921	14727
	400	12901	13902	16652	16848	15076	15801
	Mean	10371	12779	13806	13766	12680	13450
	Relative	77	95	103	102	94	100
PG	0	9190	11430	10351	11057	10507	10946
	100	9527	11570	10922	11478	10874	11323
	300	11594	13525	14502	15420	13760	14482
	400	12000	13567	15087	17257	14478	15304
	Mean	10578	12523	12716	13803	12405	13014
	Relative	79	93	95	103	92	97
TG	0	6289	9824	10977	11420	9628	10740
	100	8212	8280	10931	10574	9499	9928
	300	11252	11105	14106	13844	12577	13018
	400	12117	12767	16909	17569	14841	15748
	Mean	9468	10494	13231	13352	11636	12359
	Relative	70	78	99	99	87	92
PGG	0	8502	6672	9570	9108	8463	8450
	100	11280	8395	11139	10544	10339	10026
	300	15154	12570	14455	14794	14243	13940
	400	15203	13055	15607	16204	15017	14955
	Mean	12535	10173	12693	12663	12016	11843
	Relative	93	76	94	94	89	88
Mean	0	8078	12453	11101	12354	10997	11969
PA-TA	100	9554	13455	11743	11831	11645	12343
	300	11611	14119	15769	14883	14096	14924
	400	13112	14469	17697	16671	15487	16279
	Mean	10589	13624	14077	13934	13056	13879
	Relative	79	101	105	104	97	103
Mean	0	7740	10627	10664	11239	10068	10843
PG-TG	100	8870	9925	10927	11026	10187	10626
	300	11423	12315	14304	14632	13169	13750
	400	12059	13167	15998	17413	14660	15526
	Mean	10023	11509	12973	13577	12021	12686
	Relative	75	86	97	101	89	94
<i>ANOVA<sup>a</sup> and Mean Comparison<sup>b</sup></i>							
Previous land use (PLU)		**	**	**	NS	**	***
<i>LSD between PLU</i>				1100			
Mineral N fertilization (N)		**	**	**	**	**	***
<i>LSD between N</i>				768			
PLU x N		**	**	NS	**	**	**
<i>LSD within PLU</i>		959	1177		1497	1009	1188
<i>LSD otherwise</i>		1314	1441		1532	1131	1229

<sup>a</sup>NS, not significant; \*\* P<0.01; \*\*\* P<0.001

<sup>b</sup>Least Significant Difference (P<0.05)

<sup>c</sup>Mean annual DM yield (2002-2005) of PA = 100

Table 5. Dry matter yield (kg DM ha<sup>-1</sup>) of grazed grass and grass-clover swards of different age during 2003, characterized by a very dry summer. N application: 300 kg ha<sup>-1</sup> on pure grass swards, 150 kg ha<sup>-1</sup> on grass-white clover swards.

Grassland type	Sowing year	Dry matter yield in 2003	Clover content in the dry matter (%)
Pure grass	1996	100 <sup>a</sup>	
	1997	97 <sup>a</sup>	
	1998	106 <sup>ab</sup>	
	1999	101 <sup>a</sup>	
	2000	118 <sup>ab</sup>	
<i>100= ...kg ha<sup>-1</sup></i>		<i>11439</i>	
Grass-white clover	1996	100 <sup>a</sup>	16-51-51 <sup>(1)</sup>
	1997	89 <sup>ac</sup>	12-80-58
	1998	72 <sup>c</sup>	21-93-71
	1999	85 <sup>ac</sup>	16-87-55
	2000	109 <sup>b</sup>	33-81-59
<i>100= ...kg ha<sup>-1</sup></i>		<i>12639</i>	

Different letters indicate significant differences at p<0.05

<sup>(1)</sup>: clover content in spring- summer- autumn

### 5.3 Clover content

Figure 1 shows the evolution of white clover during the period 2002-2005. Data are given for 0 and 100 kg ha<sup>-1</sup> N. As expected the white clover content was very low when 300 and 400 kg ha<sup>-1</sup> N was applied.

The establishment of grass-clover in arable land guaranteed a high clover content immediately after establishment. Three and a half years later the clover content in swards established in previous arable land continued to be higher than in swards established in former grassland. Within this period, the cumulative white clover yield in PA was 3.5-4 times higher than the clover yield in PG and TG.

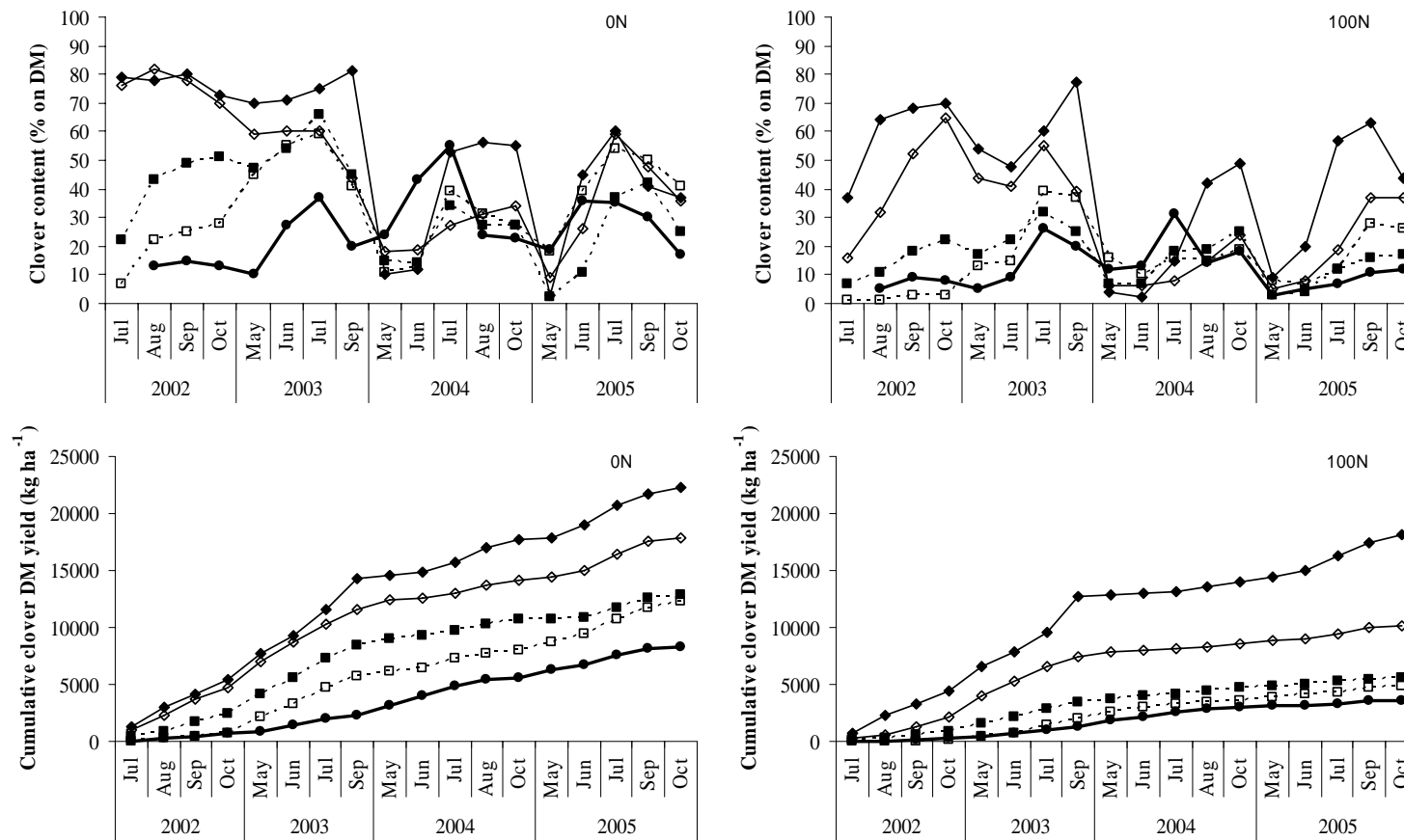

Fig. 1. White clover content in the harvested forage and cumulative clover DM yield in newly established grass-clover swards related to previous land use and to mineral N fertilization of 0N and 100N. Period 2002-2005. Cutting regime: simulated grazing management. PA (solid line, closed diamond), TA (solid line, open diamond), PG (dashed line, closed square), TG (dashed line, open square): previous land use respectively permanent and temporary arable land, permanent and temporary grazed grassland; PGG (solid thick line, closed circle) = reference: undisturbed permanent grassland, grazed previously.

## 5.4 Residual mineral soil nitrogen

Figure 2 indicates that up to a N dressing of 300 kg ha<sup>-1</sup>, residual mineral soil nitrogen remains very low. During the year of establishment the highest values were found in swards installed in previous grassland which is no surprise. From the first full harvest year on, the highest values were found in the PGG sward.

Again arable land as a previous crop offers the best guarantee for low residual mineral soil nitrogen.

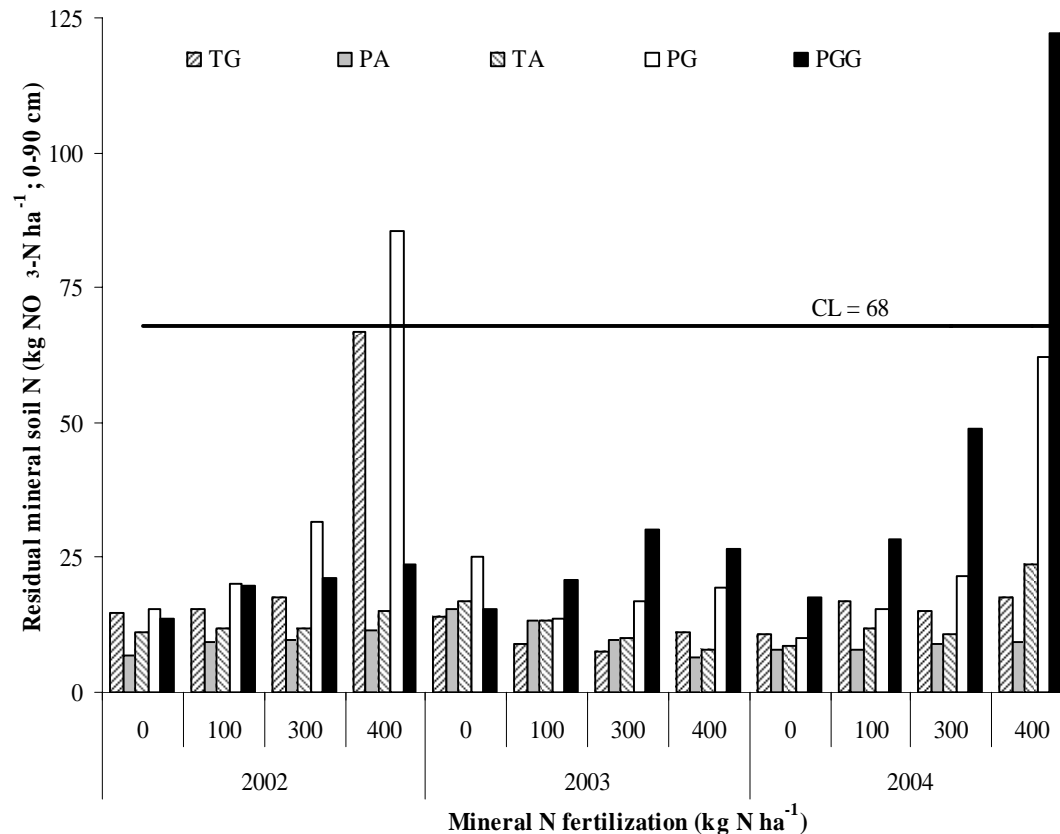

Fig. 2. Residual mineral soil N (kg NO<sub>3</sub>-N ha<sup>-1</sup>; 0-90 cm) in newly established grass-clover swards related to previous land use and mineral N fertilization. Period 2002-2005. Cutting regime: simulated grazing management. PA, TA, PG, TG: previous land use respectively permanent and temporary arable land, permanent and temporary grazed grassland; PGG=reference: undisturbed permanent grassland, grazed previously. CL = critical level of residual soil NO<sub>3</sub>-N within the soil profile 0 - 90 cm.

## 5.5 Can temporary grassland take advantage of plant breeding?

The mean white clover share in new plots dressed with 300 kg ha<sup>-1</sup> N and 400 kg ha<sup>-1</sup> N was 6% versus 8% in PGG. Differences in performance are unlikely due to a difference in clover share. Data presented in Table 4 allow calculating an overyears DM yield benefit of 5% for the new swards compared to the 36 years old PGG sward (data averaged over PA, TA, PG, TG dressed with 300 kg ha<sup>-1</sup> N and 400 kg ha<sup>-1</sup> N). Although it is substantial, this yield benefit is surprisingly low, if one knows that the PGG sward, established in 1966, was sown with a seed mixture of white clover and grasses: both perennial ryegrass and less productive grass species as meadow fescue (*Festuca pratensis* L.), smooth meadow grass (*Poa pratensis* L.), cocksfoot (*Dactylis glomerata* L.) and white clover. The PGG sward had been grazed until 2002. Nevens en Reheul (2003) found similar results under a grazing regime.

Based on data from the Dutch and Belgian National List trials, Van Wijk and Reheul (1990) calculated an annual progress in DM yield in ryegrasses of 0.5%. Extrapolating these data, one should expect a yield benefit between 1966 and 2002 of about 15-20%.

The Belgian National List trials are unique in Europe since they include continuously (from 1963 on until 2007) the same reference varieties: 'Vigor' in the group of late perennial ryegrasses and 'Lemtal' in Italian ryegrass. Chaves *et al.* (in preparation) calculated a significant ( $P < 0.001$ ) yearly DM increase of 0.32% in late perennial ryegrass, with the highest progress (0.36% per year) between 1966 and 1994 and almost no progress after 1994. Apparently, an old permanent grazed grass sward, is more productive than predicted from the National List trials, managed under a cutting regime.

## 5.6 The components of new grass swards: species and/or variety mixtures or single varieties?

De Vliegheer and Carlier (2002) compared species and variety mixtures with their single components during 3 years after the year of sowing (Table 6). Rarely the mixtures outyielded the most productive component and for persistence and disease resistance mixtures were always within the range of the single components. Earlier, Reheul (unpublished data), tested many combinations of 2-3 presumed complementary perennial ryegrass varieties and combinations of perennial ryegrass and timothy varieties during many years and came to the same conclusion: a mixture almost never outyields its most productive component. Although it is unlikely that mixtures offer a yield bonus, there may other reasons to prefer mixtures to establish (temporary) grassland as complementary disease resistances, palatability and persistence.

Table 6. Dry matter yield of mixtures and their components (species and varieties)  
(De Vliegheer and Carlier L. 2002)

mixture number	DM-yield of <b>the mixture</b> and its components								
	clover	meadow fescue	perennial ryegrass and <i>timothy</i>						
1			99,1	<b>100,0</b>	100,4	105,4			
2			92,8	94,6	<b>99,6</b>	100,2	100,4	103,0	105,4
3			95,9	97,0	99,3	100,4	<b>100,5</b>	105,4	
10	64,5		94,6	99,3	100,4	101,3	<b>102,7</b>	105,4	
13			99,3	101,3	103,5	<b>103,9</b>	105,4		
16		94,8	100,0	100,4	<b>101,2</b>	101,9			
17	64,5	94,8	99,3	100,4	101,3	<b>101,6</b>	101,9	103,5	105,4
19			97,0	99,3	100,4	<b>101,2</b>	101,3	105,8	
20	64,5	94,8	99,1	99,3	100,4	100,0	101,3	<b>103,0</b>	
22			94,6	<b>97,8</b>	100,2	105,4			

100= the mean of all the treatments of the experiment

LSD P 0,05 = 3,2

## Conclusion

It is our opinion that a good grass sward should never be turned down. The idea to take advantage of genetic improvement of varieties can not be the first argument to give up an old sward with a good botanical composition. If new swards are necessary, the best option is to establish them in arable land, since arable land as previous land use offers the highest yields; the longer the arable period the better. Arable crops as previous crops guarantee a good establishment of white clover and this benefit lasts for years. If old swards are to be turned down, the best option is to start an arable period with the establishment of N greedy crops. If swards really need to be re-established, the application of a cutting regime prevents potential



leaching of mineralized nitrogen, provided the yearly N application does not exceed 300 (400) kg ha<sup>-1</sup>.

## References

- Andries A., Carlier L., De Vliegheer A., Tyvaert D., Nuyts J., Guldentops R. and Thonon A. (1983) Nos prairies: amélioration et rénovation. Ministère de l'Agriculture, Service Information, Bruxelles (Eds), 56pp.
- Anonymus (1986) Graslandterminologie. Commissie Graslandterminologie in het Nederlandse taalgebied. Edited by the Ministry of Agriculture Brussels: 17 p.
- Bommelé L (2007) Growing potatoes and grass-clover after turned down grassland. PhD thesis University of Gent.
- Carlier L. (1988) Verbetering of vernieuwing van grasland. Edit L. Carlier. Uitgave IWONL, 109pp.
- Carlier L., Puia I. and Rotar I. (1998) For a better grass production - Pentru productii mai bune de furaje. Texte du Cours à l'Université de Sciences Agricoles et Médecine Vétérinaire de Cluj-Napoca (Roumanie) 246 pp. Risoprint, ISBN 973-9298-85-0
- Chaves B., De Vliegheer A., Van Waes J. and Carlier L. The evolution in genetic diversity of ryegrasses from 1962 till 2003 (in preparation)
- Conijn J.G., Velthof G.L. and Taube F. (2002) Grassland resowing and grass-arable rotations. WUR, Report 47, Wageningen University. 128 pp.
- De Vliegheer A., Carlier L., Coolen W., Hendricks G. and Bosmans P. (1986) Problems with direct drilling of grassland. *Proceedings XIth Gen. Meet. Europ. Grassld Fed.* - Troia, Setubal (Portugal) 22-26 September 1986 Ed. F.M. Borba and J.M. Abreus: 207-211.
- De Vliegheer A. and Carlier L. (2002) Grass seed mixtures of species and varieties: a higher value for agricultural use than a single variety? 24 th EUCARPIA Fodder Crops and Amenity Grasses Section Meeting "Grass for Food and Grass for Leisure", Braunschweig, Duitsland, september 2002: 70-74
- Hatch D., Easson L., Goulding K., Haygarth P., Shephard M. and Watson C. (2002) In 'Grassland resowing and grass-arable rotations in the United Kingdom. In 'Grassland resowing and grass-arable crop rotations' of the EGF Working Group Report 1: 93-104
- Humphreys J. and Casey I.A. (2002) Grassland renovation in Ireland. In 'Grassland resowing and grass-arable crop rotations' of the EGF Working Group Report 1: 79-92
- Nevens F. and Reheul D. (2003) Permanent grassland and three-year leys alternating with three years of arable land: 31 years of comparison. *European Journal of Agronomy*, 19, 77-90.
- Oxford Dictionary of English. Revised Edition 2005. ISBN-10:0-19-861057-2
- Pfimlin A., Arnaud J., Gautier D. and Le Gall A. (2003) Les légumineuses fourragères une voie pour concilier autonomie en protéines et préservation de l' environnement. *Fourrages* 174, 183-203
- Soegaard K., Eriksen J. and Kristensen I.S. (2002) Grassland cultivation in Denmark. In 'Grassland resowing and grass-arable crop rotations' of the EGF Working Group Report 1: 33-46
- Schiltz R., Aarts F., Bussink D., Conijn J., Corré J., van Dam A., Hoving I., van der Meer H. and Velthof G. (2002) Grassland renovation in the netherlands: agronomic, environmental and economic issues. In 'Grassland resowing and grass-arable crop rotations' of the EGF Working Group Report 1: 9-24
- Taube F., Wachendorf M. and Trott H. (2002) Future challenges in grassland cultivation in Germany. In 'Grassland resowing and grass-arable crop rotations' of the EGF Working Group Report 1: 67-78
- Van Wijk A.J.P. and Reheul D. (1990) Achievements in fodder crops breeding in maritime Europe. *Proceedings of the 16<sup>th</sup> Meeting of the Fodder Crops Section of Eucarpia*, Wageningen, 18-22 November 1990. In: Fodder crops breeding: achievements, novel strategies and biotechnology, A.P.M den Nijs, A. Elgersma (Eds), ISBN 90-220-1029-5, 13-18. Pudoc Wageningen.
- Weston R. 1652. A discours of husbandrie used in Brabant and Flanders: showing the wonderful improvement of Land there and serving as a pattern for our practice in commonwealth. Available via the website of Early English Books on Line (EEBO): <http://eebo.chadwyck.com/home>



Session 1

Production and Quality



# Production and quality of seminatural grassland in South-eastern and Central Europe

Zimkova M.<sup>1</sup>, Kirilov A<sup>2</sup>., Rotar I<sup>3</sup>. and Stypinski P.<sup>4</sup>

<sup>1</sup>*SARC, Grassland and Mountain Agricultural Research Institute, 974 21 Banska Bystrica, Slovakia*

<sup>2</sup>*Institute of Forage Crops, 5800 Pleven, Bulgaria*

<sup>3</sup>*University of Agricultural Sciences and Veterinary Medicine, Faculty of Agriculture, 3-5 Manastur*

*Street, 3400, Cluj-Napoca, Romania*

<sup>4</sup>*Warsaw Agricultural University (SGGW) Department of Agronomy, Nowoursynowska 159, 02-778 Warsaw, Poland*

## Abstract

Grassland covers one third to one half of agricultural land in countries of South-eastern and Central Europe. It extends from lowland to mountain areas and is a natural part of the agricultural landscape. The main traditional purpose of grassland management was to secure enough pasture for grazing herbivores and sufficient hay for winter feeding. The winter can be rather long in Central European countries, often lasting from November to May.

In the last century emphasis was placed on the environmental and socio-economical aspects of grassland management and utilisation.

The combination of different soils, altitudes and other ecological conditions makes grassland important from the viewpoint of ecological stability and biodiversity. Grassland and forest are very often adjacent in water protected areas as many springs are mainly in mountain regions. Therefore environmental restrictions are placed on grassland farming in water protected areas. Taking account of such conditions, it is important to adopt a strategy to utilise the natural production potential at low inputs of energy. However, the changing configuration of terrain and alternation of forest and grassland with narrow strips of arable land make mountain regions very interesting and highly appreciated from the view-point of landscape and biodiversity.

**Keywords:** natural grassland, climatic conditions, quality, management

## Introduction

Seminatural grasslands are the biggest natural resource of forage for herbivores. On a world scale they are estimated at over 117 m km<sup>2</sup> and in each country or region they are closely related to the style of living and traditions of rural population engaged in livestock production. Today meadows and pastures are considered not only as a source of grazing and hay for herbivores, but they also play a multifunctional ecological and social-economic role, forming an ecosystem providing habitats for flora and fauna. Grasslands as a part of the environment interact with other environmental processes e.g. climate change (Kemp and Michalk, 2005). In some cases grassland is managed to decrease fire incidents. They are crossed by tourist routes and so as they are a component of landscape they must be maintained to provide a pleasing appearance. So grasslands are an object of particular attention by the part of society that regulates their utilisation and conservation for the coming generations (EU Directive 92/43 on the conservation of natural habitats and wild fauna and flora).

## Climatic background

The area of seminatural grasslands in South-eastern and Central Europe is given in Table 1. They cover a large part of the agricultural land in Balkan countries and up to one third of agricultural land in Central European countries.

Table 1. Grassland in some South-eastern and Central European countries

Country	Grasslands, ha	% of agricultural land,
Bulgaria	1 780,121	28 %
Greece	5 715,018	43 %
Macedonia	817,000	58 %
Serbia	1 600,000	38 %
Romania	4 926,000	34 %
Poland	3 270,000	20 %
Czech Republic	968,000	23 %
Slovakia	795,000	33 %

Their use as a forage and species diversity depend on climatic and soil characteristics of the region. The greatest part of Europe is situated at moderate latitudes, with only the most southern regions in subtropical latitudes. The prevailing transfer of air masses from west (Atlantic Ocean) to east determines the relatively homogenous, but more continental climate in central Europe in comparison with Western Europe.

The continental character of the climate of the Balkan Peninsula is alleviated by the influence of the Black Sea on the east, the Mediterranean Sea on the south and the Adriatic Sea on the south-east. The climate on the Balkans has four pronounced seasons. The average January temperature, for instance in Bulgaria, is about zero (from -2 to +2°C, dropping to -10°C in the mountains), the average July temperature is 19-25°C (10°C in the mountains), the annual rainfall is 450-600 mm and up to 1300 mm in the mountains. The rainfall during the period of active vegetation from April to September is 200 to 400 mm. The climate in the southern part of the Balkans, i.e. in Greece, is Mediterranean characterised by a warm and humid winter and hot and dry summer. The extreme temperatures in winter and summer, and particularly the drought in summer are the main stress factors for the local vegetation adapted to these climatic conditions.

Central Europe climate is temperate, determined mostly by air masses coming from North Atlantic and from the region of the Azores but sometimes by continental air masses from over south-east Asia. This results in great variability in weather, both seasonal and between years. Mean air temperatures in summer vary from 16.5°C to 19°C, and in winter from 0 to -5°C. Average annual precipitation is 600 mm (450-750 mm on lowlands and higher on mountains i.e. 1200-1550 mm per year). Climatic conditions during the growing season are typical for the temperature zone, although wide differences may occur between regions. Generally there conditions for grassland production are poor because of low rainfall in summer, especially in lowland areas.

### Botanical characteristics of grassland

Semi-natural grasslands are important sources of animal feed and occupy 20-50% of agricultural land in the countries of the Balkan Peninsula (Kirilov *et al.*, 2006). Many of the pastures are situated in mountain regions and animal output depends on forage yield and quality. In these areas the soil is poor and cultivation is difficult. So grasslands play a double role, i.e. as a source of forage and provide protection from soil erosion.

In Bulgaria grasslands occupy 22.5% of agricultural land and meadows 6% of cultivated land (Kirilov and Todorova, 2004). Most of these areas (over 60%) are situated in the foothill and mountain regions of the country on steep terrain. In the mountain grasslands in Bulgaria about 50-60 grass species account for 50-90% of the sward, nearly 30-40 legumes account for 5-

10% and 150 others species account for the remainder (Lingorski and Petrov, 2001). Grassland types of meadows and pastures in the foothill up to 700m are mainly of beardgrass (*Andropogon* spp.) the yield of which is estimated at 2000-2500 kg/ha, in the mountains extending from 300 to 1800 m they are of common bent. (*Agrostis* spp.) with a yield of 1500-200 kg/ha and in the high mountain at 900-2000 m they are of matgrass type (*Nardus stricta*) with a yield of 2000-3000 kg hay per hectare.

In Serbia the grasslands are estimated to occupy about 1 600 000 ha, i.e. 28% of total agricultural land. They are rich in floristic composition and contain more than 100 species but their productivity ranges from 0.57-2.05 t ha<sup>-1</sup> (Stosic *et al.*, 1999).

In Greece range-lands occupy 40% of the area of the country and are mainly used for grazing by sheep and goats (Papanastasis, 1999; Papanastasis *et al.*, 2006). Grasslands are dominated by perennial C<sub>4</sub> species such as *Hyparrhenia hirta*, *Dichanthium ischaemum* and *Chrysopogon gryllus* and C<sub>3</sub> grasses as *Festuca* spp., *Bromus* spp., *Brachypodium* spp., *Alopecurus* spp., etc. (Papanastasis, 1999). Altitude has a great influence on species composition of grasslands, but the soil depth determines the dominant species (Papanastasis *et al.* 2003). The presence of C<sub>4</sub> plants, having a higher efficiency of solar conversion than C<sub>3</sub> plants, is explained by their higher water use efficiency than C<sub>3</sub> species (Brown and Simmons, 1979) and their resistance to drought and high temperatures (Snaydon, 1991). The plants of C<sub>4</sub> group are distributed throughout the regions of low rainfall which is characteristic of the southern Balkans. In Northern Greece (40° 47' N) at altitudes up to 400-500 m C<sub>4</sub> plants are the dominant species, while at higher altitudes dominant grasses are C<sub>3</sub> plants (Papanastasis *et al.*, 2003). However, forage quality of C<sub>4</sub> plant species is lower than that of C<sub>3</sub> plants (Akin, 1989).

In Romania grasslands occupy 34% of agricultural land. The pastures from the alpine area over 1600 m a. s. l. occupy 200 000 ha, dominated by *Nardus stricta* that has a very low forage value (Marusca *et al.*, 1999). Other pastures are of good quality owing to predominance of medium tall grasses with good nutritive value, such as *Festuca pratensis*, *Lolium perenne*, *Poa pratensis*, *Cynosurus cristatus*, *Agrostis capillaris*, *Festuca rubra*, *Agrostis rupestris*, *Festuca ovina* etc. (Razec, personal communication).

In Romania there are 4.9 million ha of grasslands comprising 3.4 millions ha of pastures and 1.5 millions ha of hay meadows.

The most productive grasslands are in the hill and mountain areas (Tables 2 and 3).

Table 2. The main vegetation types in Romania and their zonation

No	Zone and/or level of vegetation	Main vegetation types	Area ( '000 ha)	DM production (t.ha <sup>-1</sup> )
1	Steppe zone	1. <i>Festuca valesiaca</i> – <i>Stipa ucrainica</i> 2. <i>Botriochloa ischaemum</i>	140	0.6- 0.7
2	Silvosteppe zone	1. <i>Festuca valesiaca</i> – <i>Medicago falcata</i> 2. <i>Stipa capillata</i> 3. <i>Poa bulbosa</i> – <i>Artemisia austriaca</i>	350	0.8-1-0
3	Nemoral zone	1. <i>Festuca rupicola</i> – <i>Carex humilis</i> 2. <i>Festuca rupicola</i> – <i>Agrostis capillaris</i> 3. <i>Festuca valesiaca</i> – <i>Festuca rupicola</i>	550	1.0-3.0
4	Nemoral level	1. <i>Agrostis capillaris</i> – <i>Festuca rupicola</i> 2. <i>Agrostis capillaris</i> – <i>Festuca rubra</i> 3. <i>Lolium perene</i> – <i>Trifolium repens</i> 4. <i>Alopecurus pratensis</i>	2 760	2.0-4.0
5	Boreal zone level	1. <i>Festuca rubra</i> 2. <i>Nardus stricta</i> 3. <i>Poa pratensis</i>	1 000	2.0-3.0
6	Subalpine level	1. <i>Festuca ovina</i> 2. <i>Festuca rubra</i> – <i>Nardus stricta</i>	60	0.5-1.0
7	Alpine level	1. <i>Carex curvula</i> <i>Juncus trifidus</i> – <i>Agrostis rupestris</i>	40	0.3-0.6
Total			4 900	

The majority of grasslands (52%) are private and common grasslands represent 44% (owned by local councils of villages, towns, etc.), Ownership influencing the utilisation and production of grassland.

Table 3. Vegetation cover in the Romanian Carpathians

No	Altitude (m)	Ligneous vegetation	Dominate herbaceous vegetation	Dominate soil	Areas occupied by grassland (ha)
1	600-800	Storey of deciduous forests (nemoral)	<i>Agrostis capillaris</i> with hygrophilous species	Luvic-Brown Albic-Luvisols Acid Brown	1 600, 000
2	700-1500	Storey of spruce forests (boreal)	<i>Festuca rubra ssp. commutata</i>	Ferrilluvic Brown	1000, 000
3	1400-2000	Storey of dwarf stone pine groves (subalpine)	<i>Festuca ovina ssp. sudetica</i>	Iron-Humus Podzols	60, 000 - 80, 000
4	>2000	Storey of alpine grasslands	<i>Carex curvula</i> <i>Juncus trifidus</i>	Humic-Silicate	46, 000

An area of 1 955,000 ha (40%) of grassland is not restricted by natural limitations and so forage production could be increased with low input and the application of technology. An area of 351,000 ha (7%) in the mountains is covered with gravel, detritus and rocks and sp does not support forage production. About 1180,000 ha of grassland (24%) is endangered by earth-slide and erosion and on 855,000 ha grassland (17%) soil acidity restricts DM production.

In countries such as Bosnia and Herzegovina in which hills and mountains prevail, pastures occupy more than half (54%) of total agricultural land and are the main source of forage for sheep and cattle, but yields are low ( Alibegovic-Grbic and Custovic, 2002).

Botanical characteristics and potential production of Slovak Grassland is given in Table 4.



Table 4. Survey of the most important semi-natural grassland types in the mountain and sub-mountain regions of Slovakia (Krajčovič, 1999)

Grassland types	Phytosociological units	Natural production Potential (t ha <sup>-1</sup> hay)
<b>A. Grasslands at the wet and moisture sites</b>		
1. Flooded meadows	<i>Alopecurion</i>	4.0-7.5
2. Alternate wet-dry meadows	<i>Molion</i> <i>Agrostion</i>	1.5-4.0
3. Wet meadows on the constantly wet soils	<i>Stoloniferae</i>	1.5-2.5
4. Moorland and swamps	<i>Calthion</i> <i>Caricion fuscae</i> , <i>Caricion davallianae</i> , <i>Cariciondemissae</i>	0.5-5.5
5. High sedges and grasses	<i>Caricion gracilis</i> , <i>Magnocaricion elatae</i> , <i>Phalaridion arundinaceae</i>	4.0-10.0
<b>B. Grasslands at the poor sites</b>		
6. Xerophilous and subxerophilous grassland with narrow-leaved fescues	<i>Koelerio-Phleion phleoides</i> , <i>Asplenio-Festucion glaucae</i> , <i>Seslerio-Festucion pallescens</i>	0.5-2.5
7. Matgrass grassland (middle and higher altitude)	<i>Nardo-Agrostion tenuis</i> , <i>Violion caninae</i>	0.5-2.0
<b>C. Grasslands at the better sites</b>		
8. Thermophilous grassland with <i>Bromus erectus</i>	<i>Bromion erecti</i>	1.5-3.0
9. Common bent grassland	<i>Cirsio-Brachypodion pinnati</i> , <i>Polygalo-Cynosurenion</i>	1.5-3.0
<b>D. Grasslands at the fertile sites</b>		
10. Ryegrass pastures	<i>Festuco-Cynosurenion</i>	1.5-3.5
11. Oat grass meadows	<i>Arrhenatherion</i>	5.0-6.0
12. Mountain yellow oats grassland	<i>Polygono-Trisetion</i>	1.5-5.0
<b>E. Grasslands at the alpine and subalpine region</b>		
13. Matgrass grassland (high altitude)	<i>Nardion strictae</i>	0.7-2.2
14. Grassland on acidic soil	<i>Juncion trifidi</i>	
15. Grassland on calcareous soil	<i>Poion alpinae</i> , <i>Seslerion tatrae</i>	1.5-3.5
16. Tall grass grasslands at high altitude	<i>Festucion carpaticae</i> , <i>Calamagrostion arundinaceae</i> , <i>Calamagrostion vilosae</i>	
<b>F. Grasslands of the over-utilized sites</b>		
17. Nitrophilous grassland of the folded and over-grazed pastures	<i>Rumicion alpini et obtusifolii</i> , <i>Agropyro-</i> <i>Rumicion crispae</i> , <i>Urtica dioica</i> , <i>Cirsium sp.</i>	-
18. Nitrophilous grassland of the over-manured meadows ( by slurry or urine)	<i>Geranium sp.</i> , <i>Anthriscus sylvestris</i> , <i>Heracleum sphondylium</i>	-
<b>G. Grasslands of the abandoned or partly abandoned sites</b>		
19. Mesophilous grassland overgrown by spreading tall grasses and herbs	<i>Brachypodium pinnatum</i> , <i>Avanula planiculmis</i> , <i>Calamagrostis epigeios</i> , <i>Trollius altissimus</i> , <i>Deschampsia caespitosa</i>	1.3-6.0
20. Wet meadows overgrown by tall herbs, grasses and sedges	<i>Felipendula ulmaria</i> , <i>Mentha longifolia</i> , <i>Trollius altissimus</i> , <i>Deschampsia caespitosa</i> , <i>Juncus effusus</i>	
21. Abandoned grasslands overgrown by trees and shrubs	<i>Corylus avellana</i> , <i>Prunus spinosa</i> , <i>Juniperus communis</i> , <i>Picea abies</i> , <i>Salix sp.</i> , <i>Alnus sp.</i> , <i>Rubus sp.</i>	

Mountain regions typically are combinations of forests, meadows and pastures. Arable land occupies only a small proportion of the area. Types of soils vary from low (intra-montane hollows) to sub-alpine and alpine altitudes. This combination of different soils, altitudes and other ecological conditions makes grassland important from the viewpoint of ecological stability and biodiversity. Grassland and forest are very often adjacent in water protected

areas as many springs are mainly in the mountains. Therefore environmental restrictions are imposed on grassland farming in water protected areas. So it is important to adopt a strategy to utilise the natural production potential at low inputs of energy. However, the changing configuration of terrain and alternation of forest and grassland with narrow strips of arable land make mountain regions very interesting and highly appreciated from the view-point of landscape and biodiversity.

Anyway, one of a great problem in Slovakia, but also in other central European countries, is under utilisation of grassland, its self-afforestation and later abandonment.

Under-utilisation and/or abandonment of grassland in the Kremnické Vrchy Mountains (central Slovakia) have led to the natural self-afforestation of 12.22% of its area and in the near future can achieve 30% of the total area, if the measures of appropriate management are not considered (Uhliarova *et al* 2005).

Grassland communities exist just as well in a fertile as in an extremely poor soil. They occupy boggy soil and dry sites. They are located in river valleys and in high mountains. Therefore this range is the basis of classification of Polish grasslands (Grzyb and Prończuk, 1995) that is partly presented in the Table 5 (Stypinski *et al.*, 2006).

Table 5. The representative plant communities and production potential of different grassland habitats in Poland (Grzyb and Prończuk 1995)

Type of meadows	Plant communities	DM production potential (t ha <sup>-1</sup> )	
		Actual	Possible
Marshy meadows	all. <i>Arrhenatherion</i> Br-BI	3.0-4.0	6.0-10.0
	all <i>Cynosurion</i> R.Tx		
	o. <i>Arrhenatheretalia</i> Pawł.	4.0 – 5.0	6.0 -11.0
	all. <i>Phragmition</i> Koch	3.5 -10.0	6.0 -12.0
	all. <i>Magnocaricion</i> Koch	3.0 -3.5	3.0 – 3.5
Dry meadows	cl. <i>Nardetalia or Festuco-brometea</i>	1.0 -1.5	5.0 – 7.0
	cl. <i>Molinio-Arhenatheraea</i> R,Tx	1.5-2.5	6.0 -10.0
	all. <i>Calthion</i> R.RTx	2.0 -2.5	4.0 -6.0
	o. <i>Arhenatheretalia</i> Pawł	3.0 -3.5	6.0 -10.0
Muck meadows	cl. <i>Molinio-Arhenatheretea</i>	1.5 – 2.0	6.0 – 9.0
	com. <i>Phalaridetum arundinaceae</i>	2.0 -3.5	7.0-11.0
Swampy meadows	cl <i>Scheuzerio-Caricetea fuscae</i> Nordh	1.0 -2.0	1.0 -2.0
	all. <i>Eriophorum</i> grac. Nordh.	1,0-2.0	1.0-2.0
	all. <i>Magnocaricion</i> Koch	2.0 -3.0	2.0 -3.0

In this system natural, permanent grasslands in Poland are divided into three typological groups: flooded meadows (marshy meadows), dry meadows and boggy and post-boggy meadows (swamps meadows). A separate classification has been developed for mountain grasslands but it should be emphasised that grassland associations in the mountains are mostly anthropogenic resulting from replacement of forests. Some parts of mountain grassland are very rich in plant species, requiring some special active protection as lack of grazing could be one of the reasons for strong pasture degradation. For agricultural use dry meadows and pastures are the most important but for environmental purposes wet grasslands on flooded river valleys or in high mountains are much more valuable. Semi-natural grass ecosystems constitute a substantial part of natural habitats that build the I Annex of Habitat Directive. Many different grassland functions (natural, social, economic etc.) make them suitable for playing a very important role in establishing sustainable development which is essential for

the Nature 2000 network. In Poland 20 of such ecosystems exist, but some research suggests that the register of valuable grassland ecosystems in Poland is incomplete (Mróz and Perzanowska, 2003).

Nowadays researchers stress that plant communities (or whole ecosystems) rather than single species should be protected (Mróz and Perzanowska, 2003). The origin of Polish grasslands determines the ways of the protection. It is commonly considered that the best way is extensification (grazing, mowing) (Perzanowska and Mróz, 2003; Stypiński and Grobelna, 2000). Active protection prevents spontaneous succession and, consequently, protects plant communities and species that are at risk of extinction. These goals could be achieved by imposing an appropriate utilisation for each ecosystem.

### *Grassland management*

The climatic conditions in southern Europe, as compared to those in Central and Northern Europe do not favour uniform growth of grasses during the growing season. The yield of grass in countries such as Italy is highest during primary growth and accounting for up to 2/3 of annual yield, while in Finland the yield from the spring growth is 30% of the annual yield (Peeters and Kopec, 1996). The uneven growth and yield of grasses during the growing season is reflected on the systems in which they are used, including grazing after harvesting or growing forage crops (Kirilov *et al.*, 2006, Wilkins and Kirilov, 2003).

The characteristics of the system in which meadows and pastures are used in the Balkans depends on the farm structure. In Balkan countries most of the grassland is municipal or state land that is used by all animal owners without any control of stocking rate, duration of grazing, fertilisation and cutting rejected areas etc. Sometimes the owners of grazing animals pay token grazing fees for use of the pasture but are not sufficient to improve and increase forage yield and quality. These reasons, together with the climatic characteristics of the region, explain the low yields. In the mountain regions, grasslands are the main and only forage resource. They are mainly used extensively for grazing and hay making for winter. Hay made by hand, particularly on steep slopes, together with straw, maize stalks and other crop by-products are the basis of feeding most ruminants in winter (Wilkins and Kirilov, 2003). Making haylage in large bales is still not yet widespread. The use of the pastures is related to the number of ruminants, sheep and cattle. The main problem in the last one or two decades is the decrease in sheep and cattle numbers in some countries on the Balkans (Table 6), which results in complete abandonment of grassland (both large and small areas).

Table 6. Livestock numbers in Bulgaria

	1985	1990	1995	2000	2005
Total cattle	1,751	1,575	638	682	672
Sheep	10,500	8,130	3,398	2,549	1,693
Goats	473	432	795	1,046	718

Source: Statistical yearbook, National Statistical Institute, Sofia, 2005

Absence of grazing results in growth of weeds species, shrubs and trees. In the mountain pastures of Bulgaria area of bracken invasion is increasing by 1 to 3% every year (Lingorski and Petrov, 2001).

In recent years there has also been a decline in material and financial resources to improve grassland management and utilisation in Romania.

Changes in animal numbers in Slovakia are shown in Table 7. It is clear that numbers of animals (potential grazers) have decreased considerably since 1990 and thus about one quarter (approximately 200, 000ha) of seminatural grassland is not fully utilised.

Table 7. Evolution of cattle and sheep numbers in Slovakia (heads)

Year	1990	2000	2002	2004
Cattle (total)	1 563,000	646,000	608,000	540,000
Dairy cows	579,000	274,000	260,000	232,000
Sheep	600,000	348,000	316,000	321,000

Source: Statistical Yearbook, Bratislava, 1990, 2000, 2002, 2004

In contrast to Bulgaria, the large number of sheep and goats in some regions of Greece results in abuse of pastures – usually overgrazed with serious consequences to their productivity and persistence (Papanastasis, 1999).

### *Grassland forage quality*

Animal productivity depends on forage nutritive value or quality. Quality includes many forage characteristics, such as chemical composition, content of energy and protein, digestibility, intake etc. Composition and nutritive value of forages grasses change during the growth period with a tendency to decrease throughout the growing season (Todorova and Kirilov, 2002). The degree of decrease in nutritive value depends on the dominant species in grassland swards. The quality of different grass depends on their evolutionary stage. The warm season grasses have a higher content of cell wall (NDF), which has low digestibility (Buxton *et al.*, 1995) and accumulate less non-structural carbohydrates – fructosans (Chatterton *et al.*, 1988), which have high digestibility. Grasses, such as *Festuca arundinacea* Schreb., *Bromus inermis* Leyss, *Agropiron cristatum* Schreb., *Eragrostis curvala* Nees have a higher content of cell walls and lignin and lower digestibility than, for instance, that of ryegrass *Lolium perenne* L (Naydenova *et al.*, 2003), but they are better adapted to the climate on the Balkans. Ryegrass is better adapted to a cooler humid climate (Nelson and Moser, 1994), such as that in Western Europe. Increasing temperature which impacts on plant growth and development reduces plant digestibility (Buxton *et al.*, 1995). The forages grasses from hot climatic regions have lower digestibility and quality than those from cooler climates and this determines the species and productivity of grazing animal. So sheep and goats are predominant Southern European countries as they are better adapted to the available forage resources and climatic conditions of that region (Kirilov *et al.*, 2006).

Forage quality can be estimated using the so-called Forage Quality Index (Kirilov, 2000). This estimation is based on intake of forage and content of net or other energy, depending on the system adopted to estimate forage energy value. The Quality Index represents the relation between energy quantity ingested by the animal and that required for maintenance when fed *ad libitum*. The Quality Index can be used to compare nutritive qualities of forages for ruminants.

Forage quality is measured not only by the quantity, but also by the quality of the animal output produced. Grazing has a positive influence on the quality of milk and milk products. Milk and meat from ruminants are included in the few sources of polyunsaturated fatty acids in human nutrition which are related to decrease in cardio-vascular disease and cancers (Willett, 1997). In recent studies it has been found that there is a positive relationship between the concentration of conjugated linoleic acid (CLA) in milk and the proportion of grazing or fresh forage in diet of dairy cows (Ward *et al.*, 2003; Elgersma *et al.*, 2006). Content of fatty acids, including polyunsaturated fatty acids and especially  $\alpha$ -linolenic acid which is a source of CLA, changes in natural swards during the growing season and that leads to changes in their content in sheep milk (Mihailova *et al.*, 2003). The total amount of polyunsaturated fatty acid in the mountain pastures is highest in May-June and decreases thereafter (Odzhakova *et*

*al.*, 2005). Grasses differ in their content of fatty acids and through breeding and management their composition can be changed in ruminant products (Dewhurst *et al.*, 2001).

Mineral content in pastures depends on the age of the sward and mineral content in soil. It was found that selenium level is higher in pastures near rivers and decreases with increase in altitude from 400 to 800 m (Petrova *et al.*, 2000). The low selenium concentration in the grass of mountain pastures does not meet sheep requirements and results in decrease in their fertility. Addition to selenium in sheep rations reduced the number of barren ewes and lamb mortality 2-3 times (Petrova *et al.*, 2000).

### *Grassland and environmental value*

The significant ecological role of meadows and pastures is emphasised in many publications. Also many authors focus on a large number of factors that endanger semi-natural grasslands (Załoski, 2002; Stypiński and Grobelna, 2000; Stypiński and Piotrowska, 1997, Twardy *et al.* 2006). A few, such as flooding, erosion and succession are natural processes. However, the main reasons for grassland transformation are human influences (i.e. abandonment, diverting water, burning, eutrophication). Elimination of these influences is one of the most important tasks required to maintain and protect grassland biodiversity in Poland (Perzanowska and Mróz, 2003).

The Agenda 2000 package which was adopted for the period 200-2006 changed the basic rules of Common Agricultural Policy of EU. The present goals of CAP could be defined as: competitiveness in the agricultural sector, environmentally friendly production of good quality products, a fair standard of living for farmers, income stability and simplicity in agricultural policy (Cropper and Del Pozo-Ramos, 2006). Implications of CAP reform are also very important for grassland production which is likely to be oriented more towards environmental security than towards agricultural intensity. In Poland, as in other countries especially in Central Europe, grasslands have the highest environmental value in agricultural systems and the existence of various types of grassland must be preserved (Rychnovska and Parente, 1997). The ecological role of Polish grasslands is appreciated by many people, not only agronomists or grassland researchers. It is known that grasslands play an important role in water balance, in landscape planning; they are also very important in climate change and environmental conservation (as a habitat of rare animal and plant species). Ecologists underline the role of grassland biodiversity, the positive impact of large green areas on human psychological health and even in inspiring art and culture. Also citizens living in large built-up areas need lovely, varied landscapes and places for leisure and recreation (Kozłowski and Stypinski, 1997).

### *Perspectives*

As can be seen, it is not possible to treat grasslands only as a source of forage and hay for animals. Probably in future the role of grassland in intensive milk production will decline but possibilities for grassland are good for beef and sheep production in the mountains. At present grasslands fulfil many different functions in the environment and their biodiversity provides them with an additional advantage. Though production potential of grassland can be increased by about 50%, increase in yield is of declining importance (it is of course possible to do so by improvement in grassland management and fertilisation) but use of grasslands under low input conditions to maintain their productivity and their role in the countryside is gaining increasing importance. It is also very important to maintain grasslands' stability and preserve grassland habitats and communities of rare plant. It needs special support from government and the introduction and implementation of some agri-environmental agreements.

## Conclusion

The tendency to reduce sheep and cattle numbers in many countries in the Balkans and Central Europe poses the serious problem of grassland utilisation and maintenance in these countries. In some regions it is necessary to increase the number of animals to graze and maintain pastures. However, in some cases extensification could play a positive role in creating greater biodiversity, a conservation aim for the future generations. In South-eastern and Central European countries the inclusion of areas as habitats of rare grasses and birds, in the European Ecological Network *Natura 2000*, resulted in a clash of interests between society on the one hand and the owners of land and forests in the protected territories on the other. The lack of sufficient information and agreements between society and owners is a problem to be solved by politicians and legislative authorities.

## References

- Akin D. E. (1989) Histological and physical factors affecting digestibility of forages. *Agronomy Journal*, 81, 17-25.
- Alibegovic-Grbic S. and Custovic H. (2002) Some measurement in changing botanical composition and increasing of biodiversity on grasslands. In: Multi-function grasslands. Durand J.L., Emile J.C., Huyghe C. and Lemaire G. (eds.) *Grassland science in Europe*, 754-755.
- Brown R. H. and Simmons R. E. (1979) Photosynthesis of grass species differing in CO<sub>2</sub> fixation pathways. I. Water-use efficiency. *Crop Science*, 19, 375-379.
- Buxton D.R., Martens D.R. and Moore K.J. (1995) Forage quality for ruminants: plant and animal considerations. *Proc. Animal science*, 11-121.
- Cardasol V., Ciubotariu C. and Popovici D. (1997) Research and results concerning the utilisation of the permanent pastures in Romania, Anniversary vol. „50 years of Research in the field of Forage Crops”, ICPCP Braşov, Romania.
- Cropper R., Del Pozo-Ramos M. (2006) Impacts of CAP reforms on animal production systems *Grassland Science in Europe*, 11, 615-623.
- Dewhurst R.J., Scollan N.D., Youell S.J., Tweed J.K.S. and Humphreys M.O. (2001) Influence of species, cutting date and cutting interval on the fatty acid composition of grasses, *Grass and Forage Science*, 56, 68-74.
- Elgersma A., Wever A.C. and Nalęcz-Tarwacka T. (2006) Grazing versus indoor feeding: effects on milk quality. In: Loveras J., González-Rodríguez A., Vázquez-Yañez O., Piñeiro J., Santamaria O., Olea L. and Poblaciones M.J. (eds.) Sustainable Grassland Productivity, *Grassland Science in Europe* 1, 11, 419-427.
- Grzyb S., Pronczuk J. (1995) Podział i waloryzacja siedlisk łąkowych oraz ocena ich potencjału produkcyjnego. IMUZ.
- Chatterton N.J. *et al.* (1988) Chatterton N. J., Harrison P. A., Bennett J. H. and Asay K.H. (1989) Carbohydrate partitioning in 185 accessions of Gramineae grown under warm and cool temperatures. *Journal Plant Physiology*, 134, 169-179.
- Kasperczyk M., Szewczyk W. (2006) Polish grassland farming after joining the European Union. In: Grassland – part of mountain agriculture and landscape . *Proceedings of the Conference 27-28 September*, GMARI, Banska Bystrica, 28 -32.
- Kemp D.R. and Michalk D.L. (2005) Grasslands for production and environment. In: Grassland: a global resource. Ed. D.A. McGilloway. *Proceedings of 20<sup>th</sup> IGC*, Dublin 26 June-1 July 2005, 183-208.
- Kirilov A. (2000) Estimation of yield according to forage quality. In: *Grassland science in Europe*, vol. 5, eds. Soegaard K., Ohlsson C., Sehested J., Hutchings N.J. and Kristensen T, 163-165.
- Kirilov A. and Todorova P. (2004) Development of forage areas and forage resources in Bulgaria during the period of transition. In: Lüscher *et al.* (eds.), Land Use Systems in Grassland Dominated Regions., *Grassland Science in Europe*, vol.9, 855-857.
- Kirilov A., Porqueddu C., Razec I. and Pacinovski N. (2006) Forage resources for sheep on the Balkans and in the Mediterranean region. *Proceedings, Sheep Production in Europe: State and Perspectives*. Workshop, 7-8-September 2006, Pleven Bulgaria (in press).
- Kozłowski S., Stypinski P. (1997) The grassland In Poland In the past, present and future *Grassland Science in Europe*, 2, 19-29.
- Krajčovič V. (1999) Low-input grassland production systems for livestock feeding. Final report for Food and Agriculture Organisation of the United Nations. Banská Bystrica, 133.
- Lingorski V. and Petrov P. (2001) Grassland forage production and grazing in the mountain region of Bulgaria – current situation and major issues. *Journal of Mountain Agriculture on the Balkans*, 4, (4-5), 263-276.

- Main Statistical Office (2005) (Rocznik Statystyczny GUS Warszawa ).
- Marusca T., Neagu M. and Mocanu V. (1999) Strategies of Mountain Agriculture on the Balkans, 2, (1), 67-73.
- Mihailova G., Odjakova T., Moekel P., Jareis G. and Kafrdjiev V. (2003) Dynamics of the fatty acids contents in milk throughout the grazing season of sheep. *Journal of Mountain Agriculture on the Balkans*, 5, 455-471.
- Mroz W. and Perzanowska J. (2003) Siedliska przyrodnicze – nowy przedmiot ochrony. In *Ekologiczna sieć Natura 2000. Problem czy szansa*. Instytut Ochrony PAN, Kraków. Makomska-Juchiewicz M., Tworek S. (eds ), 67-78.
- Naydenova Y., Pavlov D., Katova A. and Day P. (2003) Estimation of chemical composition and digestibility of perennial grasses by regression equations. In: Kirilov A., Todorov N. and Katerob I. Optimal forage systems for animal production and the environment. (eds) *Grassland Science in Europe*, 8, 211-214.
- Nelson C.J. and Moser L.E. (1994) Plant factors affecting forage quality. In: Forage quality, Evaluation, and Utilisation, (Ed.) Gearge C, Fahey, Jr. Madison, Wisconsin, USA, 115-154.
- Odzhakova Ts., Mihaylova G. and Kafedzhiev V. (2005) *Journal of Mountain Agriculture on the Balkans*, 8, 5, 620-631.
- Papanastasis V. and Mansat P. (1996) Grasslands and related forage resources in Mediterranean areas. *Proc. of 16th EGF Meeting*, Grado (Gorizia), Italy, September 15-19, 47-57.
- Papanastasis V. P. (1999) Grasslands and woody plants in Europe with special reference to Greece. In: Grassland and Woody Plants in Europe. Papanastasis V.P., Frame J., Nastis A.S. (eds.) *Grassland Science in Europe*, 4, 15-24.
- Papanastasis V.P., Vrahnakis M.S., Chouvardas D., Iovi K., Berdeli B. and Ispikoudis I. (2003) Role of altitude and soil depth in productive potential of natural grasslands of Macedonia, northern Greece. In Kirilov A., Todorov N. and Katerob I. (eds), Optimal forage systems for animal production and the environment, *Grassland Science in Europe*, 8, 21-24.
- Peeters A. and Kopec S. (1996) Production and productivity of cutting grasslands in temperate climates of Europe. In: Grassland and Land Use Systems. Parente G. Frame J. and Orsi S. (eds.). *Grassland Science in Europe*, 1, 59-73.
- Perzanowska J. and Mróz W. (2003) Ekstensywne użytkowanie jako podstawa utrzymania siedlisk półnaturalnych. In Makomska – Juchiewicz M., Tworek S. *Ekologiczna sieć Natura 2000. Problem czy szansa*. Instytut Ochrony PAN, Kraków, 103-110.
- Petrova I., Todorova P. and Angelov L. (2000) Ecological evaluation of the selenium resources in the biota of the Troyan Balkan and the Panagyurska Sredna Gora region. *Journal of Mountain Agriculture on the Balkans*, 3, (1), 51-61.
- Pronczuk J. (1962) Typologiczne zasady zróżnicowania użytków zielonych na przykładzie wydzielonych typów frorystycznych w dolinach rzek na niżu (Typological principles of the grassland differentiation exemplified by the distinguished floristic types in lowland valleys) Biblioteczka Wiadomości IMUZ nr 5, 65-191.
- Rotar I. and Carlier L. (2005) Grassland technology, Ed. Risoprint, Cluj-Napoca, Romania.
- Rychnovska M. and Parente G. (1997) Grassland and Environment (I)- Mutual effects (II) Agricultural aspects *Grassland Science in Europe*, 2, 173 -186.
- Ryszkowski L., Goldyn H. and Araczyńska-Chudy E. (2000) Plant diversity in mosaic agricultural landscapes: a case study from Poland. In: *Planta Europa*. H. Sygne, J. Akeroyd (eds.), Swedish University of agricultural sciences Uppsala, Sweden, 281-286.
- Snaydon R. W. (1991) The productivity of C3 and C4 plants: A reassessment. *Functional Ecology*, 5, 321-330.
- Statistical Yearbook, 2004. Bratislava. 825 p.
- Stosic M., Lazarevic D. and Mrfat-Vukelic S. (1999) Effects of fertilizers on floristic and production changes in ass. *Danthonietum calycinae* at different location of hilly-mountain regions of Serbia. *Journal of Mountain Agriculture on the Balkans*, 2, (2), 178-187.
- Stypinski P. and Grobelna D. (2000) Directions of succession of plant communities on the degraded and taken out from utilization farmer grassland. *Grassland Science in Poland*, 3, Polish Grassland Society, Poznań, 151-157.
- Stypinski P., Mastalerczuk G. and Sienkiewicz-Paderewska D. (2006) Grassland production, biodiversity and sustainability. In *Grassland -part of mountain agriculture and landscape. Proceedings of the conference 27-28 September*, GMARI, Banska Bystrica, 186-191.
- Stypinski P. and Piotrowska J. (1997) Konsekwencje zaprzestania koszenia łąk w parkach narodowych na przykładzie Kampinoskiego Parku Narodowego. *Zeszyty Problemowe Postępów Nauk Rolniczych*, 453, 135-143.
- Todorova P. and Kirilov A. (2002) Changes in the permanent grassland composition and feeding value during the growing season. In: Durand J.L., Emile J.C., Huyghe C. and Lemaire G. (eds), Multi-function grasslands. *Grassland Science in Europe*, 7, 170-171.

- Twardy S., Kopacz M. and Kuzniar A. (2006) Grassland Management of the Polish Carpathians in the aspect of environmental protection. In Grassland – part of mountain agriculture and landscape. *Proceedings of the conference 27-28 September*, GMARI, Banska Bystrica, 222-226.
- Uhliarová E., Michalec M. and Zimková M. (2005) Extensive utilisation of grassland in the Kremnické Vrchy Mountains and its impact on biodiversity. Quality production and quality of the environment in the mountain pastures of enlarged Europe. Biala K., Nösberger J., Parente G. and Peeters A. (eds). *Proceedings of the 13<sup>th</sup> Meeting of the FAO CIHEAM Sub-Network on mountain pastures*. 15-17 Sep. 2005, Udine. Italy, 101-105.
- Ward A.T., Wittenberg K.M., Frobe H.M., Przybylski R. and Malcomson I. (2003) Fresh forage and solin supplementation on conjugated linoleic acid levels in plasma and milk. *Journal of Dairy Science*, 86, 1742-1750.
- Wilkins R.J. and Kirilov A. (2003) Role of forage crops in animal production systems. In Optimal Forage Systems for Animal Production and the Environment. Kirilov A., Todorov N. and Katerov I. (eds.) *Grassland Science in Europe*, 8, 283-291.
- Willett W.C. (1997) Specific fatty acids and risks of breast and prostate cancer: dietary intake. *American Journal of Clinical Nutrition*, 66, 1557-1563.
- Witek T. (1981) Waloryzacja rolniczej przestrzeni produkcyjnej Polski według gmin (Evaluation of the agricultural productive space in Poland by communes) IUNG Puławy.
- Zaluski T. (2002) Threat and protection of grassland communities. In *The Polish Grass Book*. Frey L. (ed.), 245-274.
- Zastawny J. (2003) Grassland and Pasture Crops – Poland AGPC FAO and Country Pasture Profiles .



## Temporary grassland – challenges in the future

Søgaard K.<sup>1</sup>, Gierus M.<sup>2</sup>, Hopkins A.<sup>3</sup> and Halling M.<sup>4</sup>

<sup>1</sup>*Faculty of Agricultural Sciences, Department of Agroecology and Environment, University of Aarhus, Research Centre Foulum, DK-8830 Tjele, Denmark*

<sup>2</sup>*Institute of Crop Science and Plant Breeding, Grass and Forage Science/Organic Agriculture, Christian-Albrechts-University of Kiel, 24098 Kiel, Germany*

<sup>3</sup>*GES Consulting, 27 Brownings Mead, Dunsford, Exeter EX6 7JJ, United Kingdom*

<sup>4</sup>*Department of Crop Production Ecology, Swedish University of Agricultural Sciences, 750 07 Uppsala, Sweden*

### Abstract

Intensively managed temporary grassland occurs either as part of a grass-arable rotation system or in grasslands subject to frequent renovation. Even though management of temporary grasslands varies greatly between countries, in terms of establishment, length of grass phase, cut number etc., there are some general changes that we expect will affect the management of intensive grasslands in the future and, to some extent, put pressure on grass utilization. The increasing milk yield per animal greatly affects the requirement for herbage with high content of net energy. The needs for reducing N-losses to the environment will continue the effort to develop grazing systems and total feeding rations that increase N utilization. Larger farms and herds, together with labour saving technology, has changed the utilization of the grasslands, and new management needs to be developed to overcome the logistic problems. Using bigger machinery in the field affects the yield and soil compaction, and anticipated future climate change is likely to affect the seasonality of production and forage quality, and introduce additional scope and challenges for planning the optimum use of herbage production from temporary grasslands.

Keywords: production, herbage quality, future challenges, structural changes

### Introduction

In some regions of North-West Europe grassland on dairy farms exists as part of a grass-arable rotation system. This system, with a grass phase of few years duration, has its origin in the positive residual effects of the grass on the following arable crops, in terms of increased soil fertility, and in reduced crop diseases and weeds. These benefits are especially important in organic and other low-input systems, and for some climatic regions this grass-arable system is considered essential for adequate crop yield levels to be maintained. Furthermore, there is an assumption that higher yields will be obtained in the grass phase, when compared with longer term grasslands, and the net gain of the whole crop rotation is assumed to be higher than from crops in monoculture.

Nitrogen accumulates during the grass phase, in amounts equivalent to 20 to 130 kg N ha<sup>-1</sup> year<sup>-1</sup> and, after conversion to arable land, N mineralization enhances and organic N content decreases over time (Hatch *et al.*, 2003). The amount accumulated during the grass phase depends of the sward age (Johnston *et al.*, 1994) and management, especially when cutting and grazing are compared (Hansen *et al.*, 2005). The length of the grass phase is a balance between the costs for establishment and fencing, and the benefits for the following arable crop, the yield condition in the grassland and the need for grass in the total feeding ration.

Another type of temporary grasslands is that of the frequently resown grasslands where there are usually no arable crops between successive grass crops. Improved herbage production and quality are the main reasons for resowing, and this system is economic only if the increased yield and quality offset the costs. The decline in yield or utilised output of permanent grassland has motivated farmers to renovate or resow grassland. The establishment of temporary grassland may also have resulted from the ploughing and resowing of permanent grassland that had inherent problems. Examples include grassland with poor soil drainage and presence of less desirable species (Tyson *et al.* 1992), low quantitative and qualitative productivity (Keating and O’Kiely, 2000; Gierus *et al.*, 2005), and seasonal feed shortage (Thom and Bryant, 1996; Coffey *et al.*, 2002). Criteria for timing of resowing are typically based on changes in the botanical composition of the sward; e.g. in the Netherlands grassland renovation is recommended if the proportion of perennial ryegrass (*Lolium perenne*) is less than 50%, or if the sward contains more than 10% of couch grass (*Elymus repens*) (Schils *et al.*, 2002).

The increasing genetic potential for milk production in the herd has resulted in a higher nutrient supply and efficient conversion. The deficit between the increasing energy demand and the limits in intake capacity in high yielding dairy cows has to be met by either a higher intake of concentrates or higher content of net energy of fodder crops. Improving quality of herbage needs a progressive optimisation of the management. Farmers are also under pressure to reduce their N surplus at the farm level in intensive dairy farming systems. This is especially the case where nitrate levels in groundwater have reached critical levels, most importantly in nitrate vulnerable zones, which often coincide with the location of dairy farms. A continued decrease in N inputs to grassland from mineral fertilizers is therefore expected. Other challenges in the future are the effects arising from the movement towards dairy farms of larger units, labour-saving technology, bigger machinery, high efficiency in order to reduce costs, and the impacts of climate change.

The aim of this paper is to review the main aspects of herbage production and quality in the context of temporary grasslands, focusing on the above-mentioned future conditions.

## Survey

Typical conditions for temporary grasslands in the grass-arable systems of North-West Europe are shown in Table 1. The grass swards are mostly established in autumn without a cover crop. However, in Brittany 65% is established in summer, and going more to the north spring sowing with a cover crop becomes more frequently used. Spring sowing is also used in the Netherlands, where grass-arable systems only constitute a small part. Even though a great part of grass-arable systems are located on sandy soil, irrigation is not widespread with the exception of Denmark. Yield and seasonal production must therefore be highly dependent on the actual rainfall conditions. Perennial ryegrass is the dominant grass species. However, in northern Europe the growing conditions are not sufficient for perennial ryegrass and timothy (*Phleum pratense*) is the dominant sown grass. The second most important grass species differ between countries. Clover in the sward is apparently limited in the North-West European temporary grasslands, as white clover (*Trifolium repens*) is only mentioned as a main species in Brittany and Denmark, and red clover (*Trifolium pratense*) in Norway and Sweden.

The arable phase is of limited duration, typically 1-4 years, whereas the length of the grass phase is more varied, 1-8 years (Table 1). This indicates that the length of one crop rotation varied greatly and the utilization of the benefits of grass on the arable crop also varied. The dominant arable crops are maize (*Zea mays*) together with different cereal species. This also reflects that the growth boundary for maize has moved progressively further north. The

arable species can utilize the increased N-mineralization after ploughing the grass. N-fixing legumes seem not to be main crops in the arable phase in any country. The number of cuts varies greatly from 1 to 6 cuts each year, and seems not only to be related to the length of the growing season but also to local traditions and conditions. The varying cut number indicates that the emphasis on high net energy concentration in herbage also varied.

The requirement to reduce N losses to the environment has changed the fertilization practice, arising from both EU and national regulations. However, for the time being, the conditions vary greatly between different countries in terms of fixed maximum and/or recommended N-rates to the grass, requirements for utilization of the residual effect after ploughing the grass sward, and categorising of different types of areas in relation to nitrate vulnerability.

Table 1. Temporary grasslands in grass/arable systems in North-West European countries. Results from a questionnaire filled out by colleagues in each country. The figures are mostly based on estimates of the typical situation.

Country	Region	Length (years)		Species <sup>1</sup>		% temporary of total grasslands	
		Grass phase	Arable phase	Grass			Arable (main)
				Main	Second		
Belgium	Flanders	1-3	3-	Lp,Lm	Pp	Ma, Ce, Po	<5
Denmark	All	3-4	1-4	Lp, Tr	Fe, Tp	Ma, Sb	70
England	All	4-8	2-3	Lp	Pp, Tr	Ma, Ww	
France	Brittany	4-7	2-3	Lp, Tr	Lm	Ma, Ww	80
Germany	Northern	1-3	2-4	Lp	Lm	Ma, Tr, Ry	15-20
Netherlands	South/East	3-5	1-2	Lp		Ma	10
Norway	All	Varied		Pp, Fp, Tp	Lp		
Sweden	All	3-5	0-3	Pp, Fp, Tp, Tr	Lp	Sb, W, O	70

<sup>1</sup> Grass species: Lp (*Lolium perenne*), Lm (*Lolium multiflorum*), Pp (*Phleum pratense*), Fe (*Festulolium*), Tr (*Trifolium repens*), Tp (*Trifolium pratense*), Fp (*Festuca pratensis*)

Arable species: Ma (maize), Ce (cereals), Po (potatoes), Sb (spring barley), W (spring+winter wheat), Ww (winter wheat), Tr (triticale), Ry (rye), O (oats)

Country	Establishment time	Cover crop <sup>2</sup>	Irrigation <sup>2</sup>	Main soil type	Number of cuts
Belgium	Autumn	÷	÷	Sandy and sandy loam	3-5
Denmark	Spring	+	+	Sandy and sandy loam	4-6
England	Autumn	÷	÷	Medium loams	2
France	Summer/autumn	÷	÷	Loamy – silty soils	1-2 + grazing
Germany	Autumn	÷	÷	Sandy and sandy loams	4-5
Netherlands	Spring	+	÷	Dry sandy	4-6
Norway	Spring	+ / ÷	Very little	Varying	1-3
Sweden	Spring	+	Very little	Varying	2-3

<sup>2</sup> With (+) and without (÷)

### Growth over successive years

A higher herbage production rate from newly established grass swards is one of the expectations in temporary grasslands. Under cutting conditions the yield is often reported to decrease over successive years, with the highest yield in the first harvest year, and the decrease from the first to the second year is often greater than between the other years for both grass-clover (Laidlaw, 1980; Schils, 1997) and pure grass (Jackson and Williams, 1979; Hopkins *et al.*, 1990). Unfertilized grass-clover swards, however, are reported to maintain their production, albeit at a lower level (Laidlaw, 1980; Hopkins *et al.*, 1990). Under grazing conditions the reports show a greater variation in the yield progress and there seems to be no

consistent trend. In grass-clover swards especially there is not necessarily a decline (Steen and Laidlaw, 1995; Nevens and Reheul, 2003). A lower decrease in grass-clover from year 1 to year 2 was found when grazing after a spring cut was compared with cutting only (Schils *et al.*, 1999). Tiller density of perennial ryegrass was reduced by cutting and low grazing frequency, and frequent grazing therefore favoured persistence and it maintained its botanical composition (McKenzie *et al.*, 2006). This indicates that the decrease in yield is not so pronounced under grazing as under cutting conditions.

Nitrogen fertilization is a management factor that greatly influences the production profile and yield. The build-up of soil N during the grass phase and increase in soil fertility could lead to decreasing N-response (yield kg<sup>-1</sup> N) during the grass phase. However, this has not been confirmed unambiguously. A mean decrease on sixteen sites in England from 27 to 14 kg DM kg<sup>-1</sup> N was found under cutting conditions (Hopkins *et al.*, 1990) whereas under grazing conditions the N-response was maintained at a similar level over successive years (Jackson and Williams, 1979). Other nutrients could have an additional effect and contribute to variability in results, particularly under low-input system, as Baars (2002) found that P and K level should be sufficient for a yield increase. In the 1970s-80s period the rates of fertilizer N used on many farms, and in experiments by grassland scientists, was generally higher than rates used nowadays, and the achievement of high dry matter yield was the main focus. However, high N-application and long growing periods decreases tiller density in pure grass (Alberda and Sibma, 1984) and decrease the carbohydrate reserves (Ennik *et al.*, 1980). Both conditions weaken the plants and their persistence seems to decrease. High N-rates applied to pure grass often decreases the production in the spring of the following year (Madsen and Sørensen, 1991). On the other hand lower N-rates can have a positive effect on persistence (Wilman, 1978). Thus, the fertilization level has an effect on the persistence and affects the yield progress during the grass phase.

Climatic factors, through the effects of summer drought and winter cold, could have a crucial effect on the persistence. This was exemplified by Lien *et al.* (2003), who considered winter damage to be the main reason for yield decrease under colder climates. Gregersen (1980) also showed that there was a lower rate of yield decrease over the years with irrigation than without irrigation: 55% and 68 % over five years respectively. However, the plant conditions, in terms of health, tiller density and energy accumulation in autumn are essential for high rates of overwintering. In white clover it has been found that the accumulation and utilization of non-structural carbohydrates are important in determining the extent to which different varieties survive the winter (Frankow-Lindberg and von Fricks, 1988). The autumn management therefore seems to be important for overwintering. N-application in autumn has been found to have either a positive or no effect on growth in the following spring. In a French experiment in pure grass, N-application (60 kg N ha<sup>-1</sup>) encouraged tillering and N-content in the leaves in autumn and increased the growth in the following spring, although in an Irish experiment there were no effects (Culleton *et al.*, 1991). Correspondingly, N-application in pure grass and grass-clover in autumn had a positive and no effect on the spring growth, respectively (Sørensen, 1995). High grass tiller density had a strong negative effect on clover content in spring at low temperature (Wachendorf *et al.*, 2001). This could indicate that the effect of N-application in autumn depends of the soil condition or N-mineralization rate, and for grass-clover further for the species competition. For optimizing overwintering some green leaf area seems to be necessary. In pure grass spring growth was improved with the last cut in October (France) and November (Ireland) compared with one month later (Culleton *et al.*, 1991). For white clover the leaf area index appears to be a key variable in determining clover performance over winter and through the following growing season (Wachendorf *et al.*, 2001).

In temporary grassland there are different demands on the fields depending on sward age. In the last year before ploughing there are no issues concerning overwintering, in contrast to the other years when persistence is important. Positive effects on persistence, like optimal autumn management, grazing and managing of the grass-clover competition, are important in the early years after establishment. However, this is of little relevance in the final year of the grass phase, when management can be concentrated on optimizing the production during that particular season. The need to focus on improved persistence is further strengthened by the fact that adverse residual effects on herbage yield caused by inappropriate management in the preceding year will generally be greatest in the spring, the season when the feed value, particularly digestibility of organic matter, will be at its highest.

### **Growth within the year**

Manipulation of the seasonal herbage growth curve was recently reviewed by Porqueddu *et al.* (2005) and Laidlaw *et al.* (2006). These authors described how grazing management, fertilization, irrigation and grass-clover interactions can affect the growth curve, just as the choice of grass-clover species and varieties. Manipulating the growth curve is especially important when grassland is used for grazing, or in a grazing-cutting system. Under such conditions a planned production system, for that field and between the fields, together with a supplementation plan, are useful tools to mitigate seasonality. However, on intensive dairy farms herbage quality is just as important as the growth rate. Under grazing it is difficult to be abreast of changes in supplementation for optimizing the total feeding ration. Improved pasture utilization through manipulating both herbage growth and quality, with consideration of the age of the grass sward, is a complex issue, for which the development of decision support systems may provide a conclusive answer. Under cutting, however, there is a greater need for optimizing the quality without necessarily needing to change the seasonal growth curve.

### **Legumes**

Legumes play an important role in temporary grasslands as a result of their ability to provide forage of high feed value and through their ability to contribute to the nitrogen economy of the sward through N fixation by associated rhizobial bacteria. This not only enables legumes to grow well even in the absence of other sources of nitrogen, but the fixed N can contribute directly or indirectly to the nutrition of grasses growing in mixture with the legume and to crops following the legume. Despite this, the use of forage legumes in Northern Europe during much of the late twentieth century declined in favour of N-fertilised grass. In recent times, the use of forage legumes has increased, due to environmental awareness and increased adoption of organic farming.

There remain some problems associated with the use of forage legumes, including difficulties in sustaining their production, problems in achieving effective conservation as silage and risks to animal health through bloat. Leaching of nitrogen can also be a problem, although forage legumes grown in combination with a grass showed levels that were similar to a pure grass crop fertilised with 200 kg N (Scholefield *et al.*, 2002).

Red clover and white clover are the two dominant forage legumes in Northern Europe. Red clover is generally best adapted to a cutting system, where it can give very high dry matter production with average yield stability in different environmental situations, but the stability decreases as the stand ages (Halling *et al.*, 2002). White clover has compared to red clover under similar conditions lower production, but it has a much higher yield stability, which increased with age. It is also more applicable to grazed and cut-and-grazed situations and adapted to a wide range of farming and environmental situations.

## Feeding quality

As dairy farms are obtaining higher levels of productivity per animal, the efficient utilization of nutrients by the high yielding dairy cow is the main concern. There are two different approaches to achieving high N-use efficiency: the correction of deficiencies, e.g. by supplementing with concentrates, and the improvement of forage quality. Much of the required N-use efficiency can be achieved by adapting the diet composition with concentrates in order to fulfil animal requirements. This might be the case with concentrates supplemented for dairy or beef cattle (Keating and O'Kiely, 2000; Coffey *et al.*, 2002). However, inclusion of larger amounts of concentrate in diets of dairy cattle also results in the import of nutrients into the farm, with consequences for the nitrogen surplus (Berentsen and Tiessink, 2003; Steinshamn *et al.*, 2006). Animals receiving concentrate supplementation may excrete larger amounts of N, masking the effect of higher crop performance obtained from renovation of the old sward, especially under grazing. Over the long term, improving the productivity of temporary grassland reduces the N input at farm level, because more animals can be maintained on grassland per unit of area after renovation. Considering improvement in forage quality for N-use efficiency, the high crude protein (CP) content and the fast protein degradation rate of forages in the forestomach of the ruminant are related to inefficiency. In such cases, the urine-N excretion is high (Bannink *et al.*, 1999), especially when energy available in the diet is limiting in the rumen. The proportion of N excreted via urine varies from 40 to 80% of total N excreted (Oenema *et al.*, 2001). High yielding animals show the highest N excretion rate in urine or milk on a per-animal basis (Kirchgessner *et al.*, 1988). Measurements in high yielding dairy cows on N excretion demonstrated that increasing the amount of undegradable protein (UDP) as a percent of CP in the diet, without limiting microbial growth in the rumen, is related to a lower urinary-N excretion (Gruber *et al.*, 1998; Davidson *et al.*, 2003). The utilization of high sugar varieties (sweet grass) demonstrated that more energy becomes available in the rumen contributing to improve N utilization in the dairy cow (Miller *et al.*, 2001). Efforts to improve efficient N use of animals fed with forages obtained from temporary grassland need to consider the protein content, especially in terms of CP fractions (non-protein N, degradable protein and UDP) in combination with the overall energy available in the diet.

Temporary grassland should aim to improve the forage quality towards a reduced N input, whether as fertilizer or as concentrate. The utilization of more productive varieties with a fast establishment rate and control of undesirable species contributes to influence positively the forage quality (Kerley and Jarvis, 1997; Bussink *et al.*, 2002). In consequence, the productivity of animals receiving forage produced from temporary grassland and the N use efficiency can be expected to improve.

Legumes in temporary grasslands vary greatly between countries (Table 1). Legumes are normally reported to have a higher content of N, lignin and minerals and lower content of NDF especially hemicellulose than grasses at a similar organic matter digestibility. In situ analyses show that the potential degradability of NDF (DNDF) in the rumen is lower for legumes than grasses, but that the rate of DNDF degradation is higher in legumes (e.g. Baumgardt *et al.*, 1962; Andrighetto *et al.*, 1993). This contributes to a faster rate of particle breakdown of legumes in the rumen associated with a rapid rate of rumen clearance, which gives the potential for a higher dry matter intake (Beever and Thorp, 1996). In a newly introduced Nordic (Norway, Sweden, Iceland and Denmark) feeding evaluating system for cattle DNDF and the rate of DNDF degradation are important parameters for calculation of net energy for lactation (NEL). Calculations in this system, for different legumes and grasses, from very young to mature stages respectively, showed that NEL for dry cows with a daily feeding level on 8 kg dry matter were reduced by 7 and 13 %, respectively, when comparing

with high yielding cows with a feeding level on 20 kg dry matter (Søgaard *et al.*, 2007). This exemplifies that the energy content in legumes does not decrease at the same rate as grasses when feeding cows with increasing yield potential. With increasing yield potential of dairy cows this relatively higher feeding value of legumes could result in an increased use of legumes in the future.

### **Effects of traffic**

Machinery utilized for spreading slurry and harvesting is getting bigger. The direction of traffic in a particular field is generally consistent from year to year. However, the position of wheel tracks within that direction is likely to be totally random (Douglas, 1994). Therefore a great part of the field will be tracked each year. The yield decrease due to traffic is always considerable, especially in spring, and there does not seem to be any significant differences between grass and clover (reviewed by Douglas, 1994). Douglas (1994) mentions results of yield reduction in the range 9-46 %. The reason is mainly a result of leaves, stem and roots being crushed rather than the influence of soil structure (Rasmussen and Møller, 1981). However, the yield is not only affected in-track but also within areas adjacent to the tyre tracks (Jorajuria and Draghi, 1997). There seems not to be a year-to-year accumulation of wheel traffic effects on yield. Douglas and Crawford (1993) found a lower decrease in yield from year 1 to 3 when comparing wheel-traffic affected areas with untreated areas. For reducing the negative effect on yield the ground/inflation pressure is reduced by broader tyres and adjusted tyre tread. Comparing two tractors with the same ground pressure but with different wheel load and with the same passes, the heavier tractor gave either the same or a greater reduction in yield than the lighter tractor. Comparing at the same traffic intensity the lighter tractor can do as much, or even greater, damage than the heavier tractor (Jorajuria and Daghi, 1997). Ball *et al.* (1997) also reported that a reduced ground pressure system successfully minimized compaction in grasslands. Thus the yield reduction seems not to be affected when the inflation pressure does not increase, but the effect on the subsoil in the long term of the higher wheel/axle load could be a higher threat (Schjønning *et al.*, 2006).

Focusing more on herbage quality on intensive dairy farms can lead to more cuts per year and thus a higher traffic intensity, which by itself will decrease the annual yield. The soil structure quality can be preserved in the most effective way by good timing of field operations, especially in relation to wet conditions (Ball *et al.*, 1997). Growth depression is normally highest in spring due to higher soil moisture in that period (Douglas, 1997). Reducing the negative effects on yield in short term grasslands seems therefore to be good timing combined with reducing the ground pressure, and eventually fixed wheel tracks, whereas the long term effects of high wheel pressure can not be solved by management.

### **Climate change**

The global climate is changing against a background of increasing atmospheric concentrations of carbon dioxide and other greenhouse gases. In North-West Europe the effects of higher temperatures and higher average precipitation (with reduced summer rain and an increase in winter precipitation) have been observed in recent years and are predicted to increase, but the extent and the frequencies of extreme weather conditions remain uncertain. Hopkins and Prado (2006) and Lüscher *et al.* (2005) have recently reviewed the expectations concerning climate change and the effects on grasslands. The expectations in grasslands are for increasing herbage yield potential and conditions that favour an increasing proportion of legumes in the sward. At a given yield it is expected that the content of crude protein will decrease and the content of water-soluble carbohydrate will increase.

These changes will affect herbage production from intensive temporary grasslands, but the effect of seasonal changes in precipitation will vary according to soil type. As a great part of temporary grasslands is cultivated on sandy soil without irrigation (Table 1) the effects on seasonality of production could be proportionately higher, with an increased herbage production in spring/early summer and in autumn, and a decreased production in mid summer due to drought. This would give a higher challenge to manage the grazing system for dairy cows in the summer for maintaining herbage allowance and herbage quality at a sufficient level. The change in herbage quality in terms of lower content of crude protein and higher content of water-soluble carbohydrates would, under grazing, be an advantageous in intensively managed grasslands, as it would improve the N-energy balance (Rearte, 2005). On the other hand, drought could reduce the digestibility of organic matter in summer due to higher content of dead plant material. Under cutting management, increased spring growth and reduced summer growth would not give rise to the same feed planning problems, but the production would be split into a high quality spring herbage and summer herbage of lower quality. A higher yield would possibly result in more cuts, with the risk of increased soil compaction, combined with the effects associated with higher soil wetness in spring and autumn.

The effect of wetter and milder winters presents a number of management issues for temporary grasslands. Heavy autumn rainfall, particularly after a dry summer period, has implications for nutrient leaching, may limit opportunities for extended grazing and affect the timing of cultivations. However, on sites where severe winter conditions lead to early sward deterioration and limit choice of forage species, there are some potential benefits arising from climate change. Warmer winter conditions also present a number of uncertainties in terms of pest and disease problems.

### **Larger farm size and herds**

With the trend to increasing farm and herd size the grass-arable system has some limitations concerning grazing by milking cows. The distance to the pasture becomes relatively long, if all grassland fields on the farm continue to be grazed. Parsons *et al.* (2004) concluded from survey data that US dairy farmers who grazed their milking cows have a smaller herd, fewer acres, more acres per cow, made less use of technology and had a lower annual milk yield in the herd compared with farmers who used confinement management. These trends are also confirmed in European countries (Kristensen *et al.*, 2005). Long distances between barn and pasture increase the labour cost and the maintenance energy required for walking increases. The number of automatic milking systems (AMS) is increasing considerably (Koning and Rodenburg, 2004). One of the differences, when AMS is introduced, is that cows are not herded. Increasing the distance from barn to pasture from 50 m to 260 m decreased the daily milk yield in early summer by 3 kg and decreased the milking frequency from 2.5 to 1.3 milkings/day, whereas the time spent grazing was the same (Spörnly and Wredle, 2004). In late summer the cows with the longest distance to pasture spent less time grazing (Spörnly and Wredle, 2004). At that time the nutritive value of the herbage is normally lower, and that could further decrease the motivation for walking the long distance. Movements in the opposite direction when cows return from the pasture to be milked can be stimulated, e.g. by feed supplementation and drinking water in the barn (Spörnly and Wredle, 2004 and 2005). Optimising the distance between barn and pasture for milking cows on farms in France and Denmark has led to the adoption a two-part crop rotation system. One part, situated at the greatest distance from the barn is used primarily for producing winter feed, and the other part is placed near the barn for cows grazing alternating with cutting. This system decreases the benefits of the traditional grass-arable system concerning utilization of the soil fertility and



reducing weeds and crop diseases. In France the grassland swards near the barn are becoming of increasingly longer duration and are renovated only when they are too damaged (Vertès, 2007). In Denmark these grasslands have a high proportion of white clover, and renovation frequency is unchanged. White clover fatigue has become introduced in these fields near the barn. The clover plants emerge, then become stunted and eventually disappear within the same year. This white clover soil fatigue is most pronounced when grass-clover is established just after ploughing a grass-clover sward that had a high proportion of clover, and the problem is mainly due to extensive attacks by the clover cyst nematode (*Heterodera trifolii*) occurring at clover emergence (Søegaard and Møller, 2005). How the two-part crop rotation with an intensive grazed area and an area with low grazing pressure affect the N utilization, N build up in the soil and N losses is unknown.

Grazing contributes to landscape values and has advantages for animal welfare, and in organic dairy farming grazing is essential. Furthermore, in some countries, e.g. Sweden and Norway, grazing is necessary for dairy production due to national regulations. However, on large farms grazing systems have to be developed for overcoming constraints concerning distance to the pasture and to control cow traffic in an AMS system.

## Conclusions

Intensively managed temporary grasslands are sown and managed with the expectation of high herbage yield and quality. The milk yield in North-West European countries is estimated at 8,800-12,900 kg ha<sup>-1</sup> forage crops (Kristensen *et al.*, 2005). However, some of the tendencies described seem to impose pressure on the herbage yield potential. The large farms and labour saving technologies such as automatic milking systems have, in the case of grazing, resulted in logistics and pest problems. The requirement to reduce N losses to the environment has tightened up the regulations for N fertilization, and this could lead to decreased herbage yield. Incorporation of clover in the swards is still not a common practice in intensive European grasslands, and any possible yield decrease associated with reduced N inputs could be countered by a higher clover content. On mown grassland, the increasing demands for herbage having a high net energy content could, together with impacts arising from climate change, lead to an increased number of cuts per season, which would increase the cost per unit of production and increase the loading of the machinery.

Planning the utilization of temporary grassland is very complex, and the age of sward, animal-plant interactions, seasonality etc. need to be included. Computer models can play a role in optimising best management, and although many models have been developed they are little used or validated in practice (Porqueddu *et al.*, 2005). As there is both a requirement for low cost systems and high utilization of the grasslands there seems to be a great need for development of simple and useable decision support systems. For developing this there are still requirements for knowledge on, e.g. manipulation of the seasonality of herbage quality and interactions between management and sward age, so that the attributes of swards of different ages can be fully considered in the farm-scale management of temporary grassland.

## References

- Alberda, Th. and Sibma, L. (1984) The influence of length of growing period, nitrogen fertilization and shading on tillering of perennial ryegrass (*Lolium perenne* L.). *Netherlands Journal of Agricultural Science* 30, 127-135.
- Andrighetto I., Bailoni G., Tolosa H.F., Hartman B., Hinds M. and Sapienza D. (1993) Observations on in situ degradation of forage cell components in alfalfa and Italian ryegrass. *Journal of Dairy Science* 76, 2624-2631.
- Baars T. (2002) Reconciling scientific approaches for organic farming research. Part II. Effects of manure types and white clover (*Trifolium repens*) cultivars on productivity of grass-clover mixtures grown on a humid sandy soil. *Dissertation. Louis Bolk Institute*, pp. 345.

- Ball B.C., Cambell D.J., Douglas J.T., Henshall J.K. and O'Sullivan M.F. (1997) Soil structural quality, compaction and land management. *European Journal of Soil Science* 48, 593-601.
- Bannink A., Valk H. and Van Vuuren A.M. (1999) Intake and excretion of sodium, potassium and nitrogen and the effects on urine production by lactating dairy cows. *Journal of Dairy Science* 82, 1008-1018.
- Baumgardt B.R., Taylor M.W. and Cason J.L. (1962) Evaluation of forages in the laboratory. II. Simplified artificial rumen procedure for obtaining repeatable estimates of forage nutritive value. *Journal of Dairy Science* 45, 62-68.
- Beever D.E. and Thorp C. (1996) Advantages in the understanding of factors influencing the nutritive value of legumes. In: Younie D. (ed.) *Legumes in Sustainable Farming Systems. British Grassland Society Occasional Symposium* No. 30, 194-207.
- Berentsen P.B.M. and Tiessink M. (2003) Potential effects of accumulating environmental policies on Dutch dairy farms. *Journal of Dairy Science* 86, 1019-1028.
- Bussink D.W., Aarts H.F.M., Velthof G.L., Hoving I., van der Meer H. and van der Meer H.G. (2002) Grassland renewing in relation to environmental and economical targets. *Grassland Science in Europe* 7, 364-365.
- Coffey K.P., Coblenz W.K., Montgomery T.G., Shockey J.D., Bryant K.J., Francis P.B., Rosenkrans Jr. C.F. and Gunter S.A. (2002) Growth performance of stocker calves backgrounded on sod-seeded winter annuals or hay and grain. *Journal of Animal Science* 80, 926-932.
- Culleton N., Lemaire G. and Keane G. (1991) The effects of autumn management of grass growth in winter and spring. *Irish Journal of Agricultural Research* 30, 41-51.
- Davidson S., Hopkins B.A., Diaz D.E., Bolt S.M., Brownie C., Fellner V. and Whitlow L.W. (2003) Effects of amounts and degradability of dietary protein on lactation, nitrogen utilization, and excretion in early lactation Holstein cows. *Journal of Dairy Science* 86, 1681-1689.
- Douglas, J.T. (1994) Responses of perennial forage crops to soil compaction. In Soane B.D. and van Ouwerkerk C. (eds.) *Soil Compaction in Crop Production*, pp. 343-364.
- Douglas J.T. and Crawford C.E. (1993) The response of a ryegrass sward to wheel traffic and applied nitrogen. *Grass and Forage Science* 48, 91-100.
- Douglas J.T. and Crawford C.E. (1997) Soil compaction effects on utilization of nitrogen from livestock slurry applied to grassland. *Grass and Forage Science* 53, 31-40.
- Ennik G.C., Gillet M. and Sibma L. (1980) Effect of high nitrogen supply on sward deterioration and root mass. *Proceedings of the EGF symposium 'The role of nitrogen in intensive grassland production'*, Wageningen, 67-76.
- Frankow-Lindberg B.E. and Fricks von H.A. (1998) Population fluctuations in three contrasting white clover cultivars under cutting, with particular reference to overwintering properties. *Journal of Agricultural Science, Cambridge* 131, 143-153.
- Gierus M., Jahns U., Wulfes R., Wiermann C. and Taube F. (2005) Forage quality and yield increments of intensive managed grassland in response to combined sulphur-nitrogen fertilization. *Acta Agriculturae Scandinavica Section B – Soil and Plant Science* 55, 264-274.
- Gregersen A. (1980) Water and nitrogen fertilization to grass and grass/clover lasting for several years. *Tidsskrift for Planteavl* 84, 191-208 (In Danish)
- Gruber L., Steinwigger A., Stefanon B. and Steinwigger R. (1998) Impact of cutting frequency and fertilization of permanent grassland, and concentrate feeding level, on N excretion of dairy cows. *Grassland Science in Europe* 3, 707-711.
- Jorajuria D. and Draghi L. (1997) The distribution of soil compaction with depth and the response of a perennial forage crop. *Journal of Agricultural Engineering Research* 66, 261-265.
- Halling M.A., Hopkins A., Nissinen O., Paul C., Tuori M. and Soelster U. (2002) Forage legumes – productivity and composition. *Landbauforschung Völknerode*, SH 234, 5-15.
- Hansen J.P., Eriksen J. and Jensen L.S. (2005) Residual nitrogen effect of a dairy crop rotation as influenced by grass-clover ley management, manure type and age. *Soil Use and Management* 21, 278-286.
- Hatch D.J., Hopkins A. and Velthof G.L. (2003) Nitrogen and phosphorus cycling in grass-to-grass reseeded and grass-arable rotations. In *EGF Working Group 'Grassland Resowing and Grass-arable Rotations' Report 2*, 5-23.
- Hopkins A., Gilbey J., Dibb C., Bowling P.J. and Murray P.J. (1990) Response of permanent and re-seeded grassland to fertilizer nitrogen. 1. Herbage production and herbage quality. *Grass and Forage Science*, 45, 43-55.
- Hopkins A. and del Prado A. (2006) Implications of climate change for grassland: impacts, adaptations and mitigation options. *Grassland Science in Europe* 11, 749-759.
- Jackson M.V. and Williams T.E. (1979) Response of grass swards to fertilizer N under cutting or grazing. *Journal of Agricultural Science, Cambridge* 92, 549-562.
- Johnston A.E., McEwen J., Lane P.W., Hewitt M.V., Poulton P.R. and Yeoman D.P. (1994) Effects of one to six year ryegrass-clover leys on soil nitrogen and on the subsequent yields and fertilizer nitrogen requirements of the

- arable sequence winter wheat, potatoes, winter beans (*Vicia faba*) grown on a sandy loam soil. *Journal of Agricultural Science Cambridge* 122, 73-89.
- Keating T. and O'Kiely P. (2000) Comparison of old permanent grassland, *Lolium perenne* and *Lolium multiflorum* swards grown for silage. 1. Effects of beef production per hectare. *Irish Journal of Agricultural and Food Research* 39, 1-24.
- Kerley S.J. and Jarvis S.C. (1997) Variation in <sup>15</sup>N natural abundance of soil, humic fractions and plant materials in a disturbed and an undisturbed grassland. *Biology and Fertility of Soils* 24, 147-152.
- Kirchgessner M., Paulicks B. R. and Schwarz F. J. (1988) Veränderungen im Harnstoffgehalt der Kuhmilch bei unzureichender oder überhöhter Proteinversorgung. *Journal of Animal Physiology and Animal Nutrition* 59, 79-84.
- Koning de K. and Rodenburg, J. (2004) Automatic milking : State of the art in Europe and North America. In: *Automatic Milking – A Better Understanding. Academic publishers, Wageningen*, 27-37.
- Kristensen T., Sjøgaard K. and Kristensen I.S. (2005) Management of grasslands in intensive dairy livestock farming. *Livestock Production Science* 96, 61-73.
- Laidlaw A.S. (1980) The effects of nitrogen fertilizer applied in spring on swards of ryegrass sown with four cultivars of white clover. *Grass and Forage Science*, 35, 295-299.
- Laidlaw A.S., Nesheim L., Frame J. and Piñeiro J. (2006) Overcoming seasonal constraints to production and utilization of forage in Europe. *Grassland Science in Europe* 11, 29-43.
- Lien G., Kristensen A.R., Hegrenes A. and Hardaker J.B. (2003) Optimal length of leys in an area with winter damage problems. *Grass and Forage Science* 58, 168-177.
- Lüscher A., Fuhrer J. and Newton P.C.D. (2005) Global atmospheric change and its effect on grassland systems. In: *Grassland: a global resource* (ed. McGilloway, D.A.) *The XXth International Grassland Congress*, Cork, 251-264.
- McKenzie F.R., Jacobs J.L. and Kearney G. (2006) Effects of spring grazing on dry land perennial ryegrass/white clover dairy pastures. 2. Botanical composition, tiller, and plant densities. *Australian Journal of agricultural research* 57, 555-563.
- Madsen B.M. and Sjøgaard K. (1991) Nitrogen and grass, 1st and 2nd harvest year. *Tidsskrift for Planteavl* 95, 239-253 (In Danish).
- Miller L.A., Moorby J.M., Davies D.R., Humphreys M.O., Scollan N.D., MacRae J.C. and Theodorou M.K. (2001) Increased concentration of water-soluble carbohydrate in perennial ryegrass (*Lolium perenne* L.): milk production from late-lactation dairy cows. *Grass and Forage Science* 56, 383-394.
- Nevens F. and Reheul D. (2003) Permanent grassland and 3-year leys alternating with 3 years of arable land: 31 years of comparison. *European Journal of Agronomy*, 19, 77-90.
- Oenema O., Bannink A., Sommer S.G. and Velthof G.L. (2001) Gaseous nitrogen emissions from livestock systems. In: Follet, R.F., Hatfield, J.L. (eds) *Nitrogen in the environment: sources, problems and management*, Elsevier, Amsterdam, NL, pp. 255-290.
- Parsons R.L., Luloff A.E. and Hanson G.D. (2004) Can we identify key characteristics associated with grazing-management dairy systems from survey data? *Journal of Dairy Science* 87, 2748-2760.
- Porqueddu C., Maltoni S. and McIvor J.G. (2005) Strategies to mitigate seasonality of production in grassland-based systems. In: *Grassland: a global resource* (ed. McGilloway, D.A.) *The XXth International Grassland Congress*, Cork, 111-120.
- Rasmussen K. and Møller E. (1981) Regrowth after pre-wilting of grassland crops II. Soil compaction in connection with harvest and transport. *Tidsskrift for Planteavl* 85, 59-71. (In Danish)
- Rearte D.H. (2005) New insight into the nutritional value of grass. (Murphy J.J. ed.) *Utilisation of grazed grass in temperate animal systems. Proceedings of a satellite workshop of the XXth International Grassland Congress*, Cork, 49-59.
- Schjønnig P., Lamandé M., Tøgersen F.A., Pedersen J. and Hansen P.O.M. (2006) Reduction of soil compaction. Magnitude and distribution of stresses in the contact area between wheel and soil. *DJF rapport Markbrug* no. 127, 102 pp. (In Danish)
- Scholefield D., Halling M., Tuori M., Isolanti M., Soelter U. and Stone A.C. (2002) Assessment of nitrate leaching from beneath forage legumes. *Landbauforschung Völkenrode*, SH 234, 17-25.
- Schils R. (1997) Effect of spring application of nitrogen on the performance of perennial ryegrass-white clover swards at two sites in the Netherlands. *Netherlands Journal of Agricultural Sciences*, 45, 263-275.
- Schils R.L.M., Aarts H.F.M., Bussink D.W., Conijn J.G., Corré W.J., van Dam A.M., Hoving I.E., van der Meer, H.G. and Velthof G.L. (2002) Grassland renovation in the Netherlands; agronomic, environmental and economic issues. In: (Eds. J.G. Conijn, G.J.Velthof and F.Taube) *EGF Working Group 'Grassland Resowing and Grassland Rotation'* Report 1, 9-24.
- Schils R., Vellinga Th.V. and Kraak T. (1999) Dry matter yield and herbage quality of a ryegrass/white clover sward in a rotational grazing and cutting system. *Grass and Forage Science*, 54, 19-29.

- Spörnly E. and Wredle E. (2004) Automatic milking and grazing – Effects of distance to pasture and level of supplements on milk yield and cow behaviour. *Journal of Dairy Science* 87, 1702-1712.
- Spörnly E. and Wredle E. (2005) Automatic milking and grazing – Effects of location of drinking water on water intake, milk yield, and cow behaviour. *Journal of Dairy Science* 88, 1711-1722.
- Steen R.W. and Laidlaw A.S. (1995) The effect of fertiliser nitrogen input on the stock-carrying capacity of ryegrass/white clover swards continuously grazed by beef cattle. *Irish Journal of Agricultural and Food Research*, 34, 123-132.
- Steinshamn H., Höglind M, Garmo T.H., Thuen E. and Brenøe U.T. (2006) Feed nitrogen conversion in lactating dairy cows on pasture as affected by concentrate supplementation. *Animal Feed Science and Technology* 131, 25-41.
- Søegaard K. (1995) Autumn management of grass and clover/grass. *SP-rapport no. 22*, 18 pp. (In Danish)
- Søegaard K. and Møller K. (2005) White clover soil fatigue: an establishment problem on large and intensive dairy farms. (Murphy J.J. ed.) Utilisation of grazed grass in temperate animal systems. *Proceedings of a satellite workshop of the XXth International Grassland Congress*, Cork, 231.
- Søegaard K., Weisbjerg M.R., Thøgersen R. and Mikkelsen M. (2007) Evaluation of forage crops in the new NorFor Feeding evaluation system. *Kvæginfo* 1701, <http://www.lr.dk/kvaeg/informationsserier/kvaegforsk/1701.htm> (In Danish)
- Thom E.R. and Bryant A.M. (1996) Use of Italian ryegrass on seasonal dairy farms in northern New Zealand. 2. Milk production. *New Zealand Journal of Agricultural Research* 39, 237-244.
- Tyson K.C., Garwood E.A., Armstrong A.C. and Scholefield D. (1992) Effects of field drainage on the growth of herbage and the liveweight gain of grazing beef cattle. *Grass and Forage Science* 47, 290-301.
- Vertès, F. (2007) Per. communication.
- Wachendorf M. , Collins R.P., Elgersma A., Fothergill M., Frankow-Lindberg B.E., Ghesquiere A., Guckert A., Guinchard M.P., Helgadottir A., Lüscher A., Nolan T., Nykänen-Kurki P., Nösberger J., Parente G., Puzio S., Rhodes I., Robin C., Ryan A., Staheli B., Stoffel S., Taube F. and Connolly J. (2001) Overwintering and growing season dynamics of *Trifolium repens* L. in mixture with *Lolium perenne* L.: A model approach to plant-environment interactions. *Annals of Botany* 88 (Special Issue), 683-702.
- Wilman D. (1978) Nitrogen and Italian ryegrass 5. Growth up to 14 weeks: residual effects. *Journal of British Grassland Society* 33, 245-251.

# The effect of repeated direct sowing of grass-legume seed mixtures into grasslands on forage production and quality

Komárek P., Nerušil P., Kohoutek A. and Odstrčilová V.

*Crop Research Institute, Prague, Research Station in Jevicko K. H. Borovského 461, Jevicko 56943, Czech Republic*

## Abstract

The effect of repeated direct sowing of grass-legume seed mixtures into a grass sward on dry matter yield and quality of forage was studied between 1991 and 2006 at an experimental site Jevíčko in the Czech Republic. The treatments were permanent grassland (PG), temporary grassland (TG) as controls and directly sown grassland (DG) which was repeatedly directly sown in 1991, 1996, 2000, 2003 and 2006. The same seed mixture and rates were used for TG and DG: festulolium hybrid, *Lolium perenne*, *Dactylis glomerata*, *Trifolium pratense*, *Trifolium repens*. DG plots were directly sown with a strip-seeding drill; the sward was cultivated into 150 mm deep and wide strips with 450 mm span. The experiments were monitored at four levels of fertilization (no fertilization, P<sub>30</sub>K<sub>60</sub>, N<sub>90</sub>P<sub>30</sub>K<sub>60</sub>, N<sub>180</sub>P<sub>30</sub>K<sub>60</sub>) and harvested three times annually. The dry matter production was recorded. The parameters of forage quality were evaluated using infrared spectrometry (1995-2006). Direct sowing of mixtures into grassland increased dry matter yield on average of years from 6.93 t ha<sup>-1</sup> (PG) to 8.11 t ha<sup>-1</sup> (DG). The forage quality was higher in the treatments with N fertilizer application.

Keywords: direct sowing, grassland, forage quality, fertilization

## Introduction

Direct sowing is a non-arable technology for grassland management that is environmentally friendly. In the last decades, direct sowing has become one of the options to introduce absent plants into grassland. The introduction of legumes and grasses may positively influence the botanical composition of grassland and nutritive value of produced forage, improve forage quality and add fixed nitrogen (N) to grassland, which decreases the need for mineral N. Direct sowing into grasslands in the former Czechoslovakia was researched by the Research Institute of Pastures and Meadows in Banská Bystrica from the early 1970s (Krajčovič, 2006). Special machines for direct sowing were developed and tested there, out of which a seeding machine SE-2-024 was manufactured from 1986. This significantly influenced further research, development and practical utilization of direct sowing technology in the Czech and Slovak Republics. If we till the sward into a wider and deeper strip, the growth and development of directly sown plants is significantly faster, which is a primary prerequisite for successful introduction of directly sown species into the grassland (Kohoutek *et al.*, 2002).

## Materials and methods

The trials were established on a fluvisoil at the Jevicko site, the Czech Republic in a mild climatic region (average annual temperature 7.5 °C, annual rainfall 629 mm, altitude 342 m). Directly sown grassland (DG) was compared with permanent grassland (PG) and temporary grassland (TG). Direct seeding was performed in 1991 (a seeding machine SE-2-024) and repeated in 1996, 2000, 2003 and 2006 (a seeding machine for strip-sowing - a prototype with the grass sward cultivated into 150 mm deep and wide strips with 450 mm between strips and

with a sowing mechanism, yjord) and the same mixture and seed quantity were used (29 kg ha<sup>-1</sup>). Temporary grassland was sown only on the one occasion in 1991. The grass-legume seed mixture comprised: Festulolium hybrid (*Lolium multiflorum*. x *Festuca arundinacea*) cv. Felina (12 kg ha<sup>-1</sup>), Perennial ryegrass (*Lolium perenne*) cv. Sport (8 kg ha<sup>-1</sup>), Cocksfoot (*Dactylis glomerata*) cv. Niva (4 kg ha<sup>-1</sup>), Red clover (*Trifolium pratense*) cv. Kvarita (3 kg ha<sup>-1</sup>), White clover (*Trifolium repens*), cv. Huia (2 kg ha<sup>-1</sup>). TG was established and sown with the same mixture in 1991. Plot area was 10 m<sup>2</sup>, 4 replicates. The PG, TG and DG treatments were fertilized at four levels (no fertilization, P<sub>30</sub>K<sub>60</sub>, N<sub>90</sub>P<sub>30</sub>K<sub>60</sub>, N<sub>180</sub>P<sub>30</sub>K<sub>60</sub>), N- as nitre with limestone, P as superphosphate and K as potash salt, rates as elements. This paper reports dry matter (DM) yield in 1991-2006 and forage quality in 1995-2006. The forage quality was measured using the instrument NIRSystems 6500 equipped with sample transport module in reflectance range 1100-2500 nm, band width 2 nm, measured in small ring cups, in 2x2 replications and using the software WinISI II, vers. 1.50. The observed parameters were: crude protein, fibre, NEL (net energy of lactation), NEV (net energy of fattening), PDIE (ingested digestive protein allowed by energy) and PDIN (ingested digestive protein allowed by nitrogen). NIR calibration equations for all determinations were developed by Partial Least Squares (PLS) regression of reference values on the 1<sup>st</sup> derivative of SNV and detrended spectra. The measured results were statistically evaluated and differences between averages were tested with the Tuckey test.

## Results and discussion

DM yield was influenced by the type of grassland (Table 1). There was significant (P<0.01) increase of DM yield after direct sowing (DG) compared with a control (PG) especially in the second and third harvest year after direct sowing. The highest DM increase was observed in the first harvest year in 1992 when DM production increased significantly (P<0.01) from 5.42 t ha<sup>-1</sup> (PG) to 10.18 t ha<sup>-1</sup> (TG) and 8.91 t ha<sup>-1</sup> (DG). The DM yield increase from (DG) was mainly explained by successful growth of directly sown red clover in the first three years after direct sowing. Average DM yields from 1991-2006 were 8.11 t ha<sup>-1</sup>(DG) and 8.45 t ha<sup>-1</sup> (TG), which in both cases represent significant increases (P<0.01) when compared with (PG) 6.93 t ha<sup>-1</sup>. Long-term positive effect of direct sowing on DM yield and similar results were also reported by Frame (1992).

Table 1. Dry matter yield (DM t ha<sup>-1</sup>) 1991-2006

Treatment	DM t ha <sup>-1</sup>																avg
	Years 1991-2006																
	91	92	93	94	95	96	97	98	99	00	01	02	03	04	05	06	
PG	3.76	5.42	5.13	5.78	10.51	10.39	7.43	5.36	8.47	7.16	7.49	9.35	6.25	7.23	5.39	5.68	6.93
TG	4.57	10.18	7.51	8.68	12.40	11.11	8.47	6.72	10.89	9.47	9.20	9.53	6.97	7.36	6.23	5.98	8.45
DG	3.24	8.91	6.85	7.92	12.19	10.84	9.95	7.40	10.29	6.37	7.97	9.83	7.64	8.54	6.31	5.53	8.11
LSD <sub>0.05</sub>	0.47	1.21	0.90	0.86	1.04	0.90	0.70	0.77	0.87	1.11	0.93	0.65	0.71	0.81	0.57	0.46	0.37
LSD <sub>0.01</sub>	0.61	1.58	1.17	1.12	1.35	1.17	0.91	1.00	1.13	1.44	1.21	0.84	0.93	1.06	0.74	0.60	0.49

PG: permanent grassland, TG: temporary grassland, DG: repeatedly directly sown grassland

Also mineral fertilizer had a positive effect on DM yield (Table 2). Average DM yields from 1991-2006 increased non-significantly from 6.25 t ha<sup>-1</sup> in the treatment without fertilizer (N<sub>0</sub>P<sub>0</sub>K<sub>0</sub>) to 6.72 t ha<sup>-1</sup> (N<sub>0</sub>P<sub>30</sub>K<sub>60</sub>). DM yield increased significantly (P<0.01) with N fertilizer to 8.61 t ha<sup>-1</sup> with (N<sub>90</sub>P<sub>30</sub>K<sub>60</sub>) and a further significant increase to 9.75 t ha<sup>-1</sup> with (N<sub>180</sub>P<sub>30</sub>K<sub>60</sub>). The positive effect of nitrogen fertilizer on DM yield and forage quality was also reported by Lunnan (2004), who demonstrated that increasing N rate from 0 to 180 kg ha<sup>-1</sup>) increased DM yield from 6.66 t ha<sup>-1</sup> to 8.78 t ha<sup>-1</sup>.

Table 2. The effect of fertilization on dry matter yield (DM t ha<sup>-1</sup>) 1991-2006

Treatment	DM t ha <sup>-1</sup>																
	Years 1991-2006																
	91	92	93	94	95	96	97	98	99	00	01	02	03	04	05	06	avg
1	3.73	6.86	4.59	5.80	9.58	8.80	7.17	4.99	8.17	6.72	6.88	7.62	5.46	5.36	4.29	4.00	6.25
2	3.99	7.15	5.26	5.79	10.06	8.53	7.52	5.56	8.63	7.07	7.07	8.89	6.26	6.01	4.94	4.71	6.72
3	3.80	8.70	7.42	8.67	13.31	12.54	9.03	7.24	11.12	8.00	8.50	10.21	7.71	8.51	6.42	6.52	8.61
4	3.92	9.97	8.72	9.58	13.86	13.25	10.75	8.19	11.62	8.87	10.43	11.57	8.38	10.96	8.26	7.70	9.75
LSD <sub>0.05</sub>	0.60	1.55	1.15	1.10	1.33	1.15	0.90	0.98	1.11	1.42	1.19	0.83	0.91	1.04	0.73	0.58	0.48
LSD <sub>0.01</sub>	0.76	1.97	1.47	1.40	1.69	1.46	1.14	1.25	1.42	1.81	1.51	1.05	1.16	1.32	0.93	0.74	0.61

1-N<sub>0</sub>P<sub>0</sub>K<sub>0</sub>; 2-N<sub>0</sub>P<sub>30</sub>K<sub>60</sub>; 3-N<sub>90</sub>P<sub>30</sub>K<sub>60</sub>; 4- N<sub>180</sub>P<sub>30</sub>K<sub>60</sub>

The forage quality parameters averaged for 1995-2006 are presented in the Table 3. Crude protein concentration tended to be highest under (DG) 128.7 g kg<sup>-1</sup> and the lowest from (TG) 118.9 g kg<sup>-1</sup>, these differences are significant. Crude protein concentration from (DG) was mainly influenced by botanical composition of grassland, especially by directly sown red clover and white clover. Fibre concentration ranged from 241.5 g kg<sup>-1</sup> (PG) to 258.5 g kg<sup>-1</sup> (TG). NEL concentration was significantly highest under (DG) 5.61 MJ kg<sup>-1</sup>. Direct sowing significantly increased NEL concentration compared with temporary grassland value (TG) 5.53 MJ kg<sup>-1</sup> and 5.46 MJ kg<sup>-1</sup> (PG). NEV concentration was significantly highest in the forage from the (PG) 5.45 MJ kg<sup>-1</sup>. Direct sowing significantly increased NEV concentration 5.35 MJ kg<sup>-1</sup> compared with (TG) 5.27 MJ kg<sup>-1</sup>. PDIE concentration was highest in the forage under (DG) 81.4 g kg<sup>-1</sup> and 81.3 g kg<sup>-1</sup> under (PG), both values represent significant increase of PDIE concentration compared with 79.8 g kg<sup>-1</sup> from (TG). Direct sowing of legume-grass mixture into grassland significantly increased PDIN concentration to 77.8 g kg<sup>-1</sup> in the forage from (DG) compared with 71.5 g kg<sup>-1</sup> from (TG).

Table 3. Forage quality parameters averaged for years 1995-2006

Treatment	Crude protein (g kg <sup>-1</sup> DM)	Fibre (g kg <sup>-1</sup> DM)	NEL (MJ kg <sup>-1</sup> DM)	NEV (MJ kg <sup>-1</sup> DM)	PDIE (g kg <sup>-1</sup> DM)	PDIN (g kg <sup>-1</sup> DM)
PG	127,4	241,5	5,46	5,45	81,3	76,9
TG	118,9	258,5	5,53	5,27	79,8	71,5
DG	128,7	249,0	5,61	5,35	81,4	77,8
LSD <sub>0.05</sub>	4,9	3,7	0,04	0,05	0,7	2,9
LSD <sub>0.01</sub>	6,3	4,9	0,05	0,06	0,9	3,8

PG: permanent grassland, TG: temporary grassland, DG: repeatedly directly sown grassland

Mineral fertilizer application significantly influenced forage quality (Table 4). Averaged over the period 1995-2006, crude protein concentration increased significantly to 134.6 g kg<sup>-1</sup> in the forage from the treatment with the highest N rate (N<sub>180</sub>P<sub>30</sub>K<sub>60</sub>) compared to other rates of fertilization. Fibre concentration, however, also increased significantly (P<0.01) to 255.9 g kg<sup>-1</sup> under the N<sub>90</sub>P<sub>30</sub>K<sub>60</sub> treatment and to 254.6 g kg<sup>-1</sup> from the N<sub>180</sub>P<sub>30</sub>K<sub>60</sub> treatment compared to zero fertilization treatment (N<sub>0</sub>P<sub>0</sub>K<sub>0</sub>) value of fibre concentration 240.2 g kg<sup>-1</sup>. N fertilization influenced NEL concentration which reached 5.53 MJ kg<sup>-1</sup> in the treatment with the highest N rate, which was a no-significant increase compared with the N<sub>0</sub>P<sub>30</sub>K<sub>60</sub> treatment value of 5.51 MJ kg<sup>-1</sup> but a statistically significant (P<0.01) decrease compared with the N<sub>0</sub>P<sub>0</sub>K<sub>0</sub> treatment value of 5.61 MJ kg<sup>-1</sup>. PDIE concentration value was the highest under N<sub>180</sub>P<sub>30</sub>K<sub>60</sub> treatment (82.3 g kg<sup>-1</sup>). PDIN concentration value was significantly higher (82.5 g kg<sup>-1</sup>) in the forage from the N<sub>180</sub>P<sub>30</sub>K<sub>60</sub> treatment than in the forage from other treatments: (N<sub>0</sub>P<sub>0</sub>K<sub>0</sub>) 73.0 g kg<sup>-1</sup>, (N<sub>0</sub>P<sub>30</sub>K<sub>60</sub>) 73.3 g kg<sup>-1</sup>, (N<sub>90</sub>P<sub>30</sub>K<sub>60</sub>) 72.9 g kg<sup>-1</sup>.

Table 4. The effect of fertilization on forage quality averaged for years 1995-2006

Treatment	Crude protein (g kg <sup>-1</sup> DM)	Fibre (g kg <sup>-1</sup> DM)	NEL (MJ kg <sup>-1</sup> DM)	NEV (MJ kg <sup>-1</sup> DM)	PDIE (g kg <sup>-1</sup> DM)	PDIN (g kg <sup>-1</sup> DM)
N <sub>0</sub> P <sub>0</sub> K <sub>0</sub>	120,6	240,2	5,61	5,46	80,2	73,0
N <sub>0</sub> P <sub>30</sub> K <sub>60</sub>	121,2	248,0	5,51	5,33	80,3	73,3
N <sub>90</sub> P <sub>30</sub> K <sub>60</sub>	121,0	255,9	5,49	5,30	80,5	72,9
N <sub>180</sub> P <sub>30</sub> K <sub>60</sub>	134,6	254,6	5,53	5,34	82,3	82,5
LSD <sub>0,05</sub>	6,2	4,8	0,05	0,06	0,9	3,8
LSD <sub>0,01</sub>	7,9	6,1	0,07	0,08	1,1	4,8

## Conclusions

Repeated direct sowing of legume-grass mixture into the permanent grassland performed every 3-5 years significantly increased forage yield in comparison with permanent and temporary grassland. Increasing rate of nitrogen fertilizer increased forage yield and quality. Direct sowing into grasslands is an important technology for the production of quality forage for cattle especially by the introduction of legumes into grasslands.

## Acknowledgements

This research was supported by the research project no. MZe 0002700601 “Creation, calibration and validation of sustainable and productive cropping systems”.

## References

- Krajčovič V. (2006) Seventy years of forage and grassland research in Slovakia. In: Ferencikova D., Kizekova M., Ondrasek L. and Zimkova M. (eds.) Grassland- part of mountain agriculture and landscape. *Proceedings of the International Conference*, Sep. 27-28, 2006, Banska Bystrica, Slovakia IGER, 6-15.
- Kohoutek A., Komarek P., Odstrcilova V., Nerusil P., Tisliar E., Michalec M., Gonda L. and Ilavska I. (2002) Strip seeding of grassland. In: Agriculture information. UZPI Prague, The Czech Republic, 32p.
- Frame J. (1992) Improved grassland management. Farming Press Books, United Kingdom, ISBN 0-85236-246-3 351 pp.
- Lunnan T. (2004) How does resowing of natural meadows affect yield, forage quality and botanical composition? In: A Luscher, B. Jeangros, W. Kessler, O. Huguenin, M. Lobsiger, N. Millar, D. Suter. (eds.) Land Use Systems in Grassland Dominated Regions. *Proceedings of the 20<sup>th</sup> General Meeting of EGF*, Luzern, Switzerland 21-24 June 2004, 550-552.



# Evaluating new grass-legume mixtures for pasture improvement in a semi-arid environment

Franca A., Porqueddu C. and Dettori D.

CNR-ISPAAM, Via de Nicola 1, 07100 Sassari, Sardinia, Italy

## Abstract

In order to test new annual legumes recently available for pasture improvement in Mediterranean areas in mixture with some perennial grasses, an experimentation was carried out within the PERMED EU Project activity, in a private dairy sheep farm in Northern Sardinia. Three treatments were compared: 1) a COMPLEX grass-legume pasture mixture, based on 26 varieties belonging to 15 species 2) a SIMPLE grass-legume pasture mixture based on 5 species, including local cultivars and ecotypes, and one commercial variety and 3) an annual forage crop (AFC) based on a local mixture of oat and Italian ryegrass.

The preliminary results evidenced difficulties in the establishment of most perennials for both mixtures and also of several annuals within the COMPLEX mixture. The SIMPLE mixture achieved a better control of the invasive unpalatable thistle (*Sylibum marianum*) in the early phases, a balanced composition between grasses and legumes in winter and a good spring growth. The AFC established rapidly, allowing early grazing in late autumn and winter and a strong competition against the invasive thistle.

Keywords: pasture improvement, grass-legume mixtures, Mediterranean environment

## Introduction

Annual forage crops, mainly based on winter cereals, have represented a wide forage resource for dairy sheep farming systems, and their management, based on annual ploughing and sowing, has led to a slow but constant substitution of natural pastures, with a strong environmental impact on slope areas. Nowadays, the re-introduction of persistent pasture swards could represent a low-cost and more environmentally-friendly alternative to such annual forage crops. The difficulties found in the establishment and persistence of pastures during adverse climatic years in marginal areas have led to the conclusion that the more diversified the seed mixture, the greater the chances of achieving a productive, balanced and persistent pasture (Crespo, 1997). On the other hand, encouraging results have been obtained at a plot level by Porqueddu and Maltoni (2005) evaluating 4-species mixtures belonging to different functional types, as grass/legume and fast-annual/slow-perennial establishing species. An experimentation with the general aim of evaluating the introduction of simple and complex pasture mixtures based on new varieties recently available was carried out at a farm level.

## Materials and methods

The experimental trial was carried out during 2005-2006 in the Mr. Gavino Pulinas private farm, located in Osilo (Sardinia-Italy) at 350 m a.s.l.. The climate is typical of the central Mediterranean area, with an average annual rainfall of 550 mm. The experimental field lies on a stony calcareous soil type with pH = 6.4 and rich in organic matter (3%).

The field assigned to the trial was previously grazed during winter and spring 2005, and sprayed to control the invasive unpalatable thistle (*Sylibum marianum* L.). After the first

rains, at the end of September (29<sup>th</sup>), the field was ploughed at a depth of about 30 cm and superficially tilled. The experimental field was divided in three strips (21.5 x 165 m), each one destined to a treatment: 1) COMPLEX commercial pasture mixture by FERTIPRADO Ltd., based on 26 varieties belonging to 15 species (Table 1); 2) SIMPLE mixture by CNR, based on 5 species, including local cultivars and ecotypes and one commercial variety; 3) ANNUAL FORAGE CROP (AFC), based on a local mixture of oat and Italian ryegrass, managed conventionally, usually for direct utilisation in winter and hay production in late spring.

Table 1. Composition and sowing rate (kg ha<sup>-1</sup>) of COMPLEX and SIMPLE pasture mixtures.

<i>COMPLEX mixture</i>			
• Annual legumes		• Perennial grasses	
<i>Biserrula pelecinus</i> cv. Casbah	1	<i>Dactylis glomerata</i> cv. Currie	2
<i>Medicago polymorpha</i> cvs. Santiago, Scimitar	2	<i>Festuca arundinacea</i> cv. Demeter	1
<i>Ornithopus sativus</i> cvs. Erica and Margurita	2	<i>Lolium perenne</i> cv. Victorian	1
<i>Trifolium glanduliferum</i> cv. Prima	1	<i>Phalaris aquatica</i> cvs. Atlas, Landmaster	2
<i>Trifolium michelianum</i> cv. Paradana	2		
<i>Trifolium resupinatum</i> cvs. Prolific, Nitro Plus, Kyambro	3		
<i>Trifolium subterraneum</i> cvs. Dalkeith, Campeda	4	• Perennial legumes:	
<i>Trifolium subterraneum</i> cvs. Clare, Davel	4	<i>Medicago sativa</i> cvs. Genesis, H. River	1
<i>Trifolium subterraneum</i> cvs. Trikkala, Riverina	2	<i>Lotus corniculatus</i> cv. San Gabriel	0.5
<i>Trifolium vesiculosum</i> cv. Cefalù	1	<i>Lotus tenuis</i> cv. Estero	0.5
<i>SIMPLE mixture</i>			
• Annual grasses		• Perennial legumes	
<i>Lolium rigidum</i> cv. Nurra	5	<i>Medicago sativa</i> cv. Mamuntanas	8
• Annual legumes		• Perennial grasses	
<i>Medicago polymorpha</i> cv. Anglona	7	<i>Dactylis glomerata</i> cv. Currie	8
<i>Trifolium subterraneum</i> ecotype Funtana Bona	2		

The fertilisation was made with 200 kg ha<sup>-1</sup> of Diammonium phosphate (18-46-0), for the AFC and 300 kg ha<sup>-1</sup> of Phosphate (18% P<sub>2</sub>O<sub>5</sub>) for both mixtures. In the whole field, 15 kg ha<sup>-1</sup> of Sulphate Fe (Fe SO<sub>4</sub>) was also applied. Sowing was carried out on the 14<sup>th</sup> October 2005, with 200 kg ha<sup>-1</sup> of local seeds for AFC and 30 kg ha<sup>-1</sup> of seeds for the two mixtures. Sowing was made using a precision seeder, followed by a superficial tilling and a final rolling. Seedling establishment was estimated at the 3rd trifoliate leaf for legumes, counting the number of seedlings on 20 quadrats (25 x 25 cm) per treatment. Botanical composition was estimated with a destructive method on fresh biomass cut in a 0,125 m<sup>2</sup> ground level sample. The phenological phases from spring up to the complete senescence of each mixture component were also recorded. The field was grazed by “Sarda” bred dairy sheep, when the height of the canopy exceeded 15 cm. Before and after each grazing, biomass availability was estimated on 8 representative sample areas of 1 m<sup>2</sup> per treatment. The fresh biomass of each component was oven dried (80°C for 48 hours) and weighed for estimation of dry matter yield. Biomass production and botanical composition were also estimated at the end of spring on 4 ungrazed sample areas under fixed cages (1 x 1 m) per treatment.

## Results and discussion

In 2005-06, the site area was characterised by a rainy autumn and winter, with more than 400 mm between October and March, and a dry spring, with only 23 mm of rains between April

and June 2006. The colder temperatures were measured between January and February with 3 frost days.

As expected, the AFC emerged and established earlier than the two mixtures, with a higher seedling density, with around 700 seedlings m<sup>-2</sup> in November. SIMPLE (540 seedlings m<sup>-2</sup>) established better than COMPLEX, with about 200 seedlings m<sup>-2</sup> more. From the early phases, *S. marianum* constituted slightly less than 10% of the botanical composition in the two mixtures.

A relevant presence of *S. marianum* was recorded at the end of winter in the two mixtures. Mainly in SIMPLE mixture, it was partially balanced in spring thanks to the competitive impact of *L. rigidum* and *M. polymorpha*. This invasion constitutes a serious management problem for farmers in the area and often limits the DM availability on natural and sown swards. AFC gave early grazing in late autumn and winter, as well as in spring when hay production was compromised because of spring drought (Table 2).

Table 2 - Grazing calendar and available DMY. Turns of animal presence with indication of grazing time (number of hours) and flock composition. Herbage allowance and residual (t ha<sup>-1</sup>) at the grazings.

Grazing period		n. of days	treatment	grazing time	flock (n. ewes)	herbage allowance	herbage residual
beginning	end						
15-Dec	29-Dec	15	AFC	90	30	0.9	*
21-Feb	23-Feb	3	AFC	18	60	3.3	*
30-Mar	04-Apr	6	COMPLEX	36	30	4.1**	3.1**
12-Apr	13-Apr	2	COMPLEX	4	250		
05-Apr	10-Apr	6	SIMPLE	36	30	4.3**	3.7**
12-Apr	13-Apr	2	SIMPLE	6	250		
14-Apr	*	*	AFC	*	30	1.6	*

\* The flock was left grazing a wide field of senescing herbage on the annual forage crop, included in the experimental trial

\*\* Sum of two grazings

COMPLEX and SIMPLE mixtures were grazed only in spring, showing a slow establishment. In April, the abundance of biomass and the need to reduce the sward height of the two treatments to facilitate herbicide distribution (Glyphosate) on unpalatable thistle plants, lead to carry out a double grazing in two phases: a lighter one with 30 ewes for 6 days and a second heavier one with 250 ewes for two days. More than 4 t ha<sup>-1</sup> of available DM both for COMPLEX and SIMPLE were estimated (table 3). A high contribution of legumes was recorded, with particular emphasis on *M. polymorpha* in both mixtures. SIMPLE mixture was characterised by a strong dominance of *L. rigidum*. Regarding phenology, earlier flowering was observed in *M. polymorpha* accessions (20<sup>th</sup> March) followed by *T. glanduliferum* and subterranean clovers, while late flowering resulted for *T. vesiculosum* (28th April) within the COMPLEX mixture. Beginning of flowering was concentrated in early April for the three annual components of SIMPLE mixture. Senescence occurred earlier in *T. glanduliferum* at the beginning of June while *T. vesiculosum* dehydrated completely by the end of June.

Table 3 - Total annual DMY (t ha<sup>-1</sup>, with st.dev. in italic) and botanical composition (%) at spring in the ungrazed cages

	TREATMENT					
	COMPLEX		SIMPLE		AFC	
Total annual DMY (t ha <sup>-1</sup> )	4.2± 0.9		5.2± 0.5		5.1± 0.4	
Floristical composition (%)	MP Scimitar/Santiago	15.9	LR Nurra	42.1	Oat/Italian ryegrass	81.3
	TG Prima	10.8	MP Anglona	21.6	Other Spp.	18.7
	TR Nitro Plus/Prolific	5.1	MS Mamunthanas	3.2		
	TS Clare	4.3	TS Funtana Bona	2.7		
	TR Kyambro	2.6	Other Spp.	30.4		
	LP Victorian	0.6				
	TM Paradana	0.3				
	TS Campeda	0.2				
	MS Genesis/SanGabriel	0.1				
	Other subclovers	10.4				
	Other Spp.*	49.7				

\* = The grazing was heavy, as conventionally, and didn't permit the estimation of the residual dry matter

## Conclusions

These preliminary results highlighted difficulties in the establishment of most perennials for both mixtures, in contrast with the observations made by Porqueddu and Maltoni (2005) on similar simple mixtures at the plot level, and also of several new annual legumes within the COMPLEX mixture. Only *Trifolium glanduliferum* cv. Prima and two burr medics cvs. Scimitar and Santiago showed a good establishment for the COMPLEX commercial mixture. The SIMPLE mixture performed a better control of the invasive unpalatable thistle in the early phases, a balanced composition in winter between grasses and legumes and a high spring growth. The AFC established rapidly, giving early grazing in late autumn and winter and a strong competition against the invasive thistle. Thus, unsown species competition confirmed to be a challenge, especially in the case of grass-legume mixed sown swards where spraying herbicide is not possible.

The possibility to enhance sward productivity by exploiting the synergies existing among plant functional groups (grass/legume and fast/slow establishing species) as an alternative to high artificial inputs (e.g. organic farming) is of great importance. An optimal proportion of grass/legumes and annual self-reseeding/perennials, can favour species' establishment, improve soil covering rates and persistence. Grass-legume mixtures may also have the advantage of stabilizing yield over the growing season, which may be more important than achieving high yields, especially in Mediterranean rainfed conditions. The asynchrony of the growth cycles of grasses/legume is responsible of a reduction of within year seasonal variations; whereas the asynchrony of the growth cycles of fast/slow establishing species can reduce between year biomass variations.

## Acknowledgements

This work was supported by the EU within PERMED Project under the contract PL 509140.

## References

- Crespo D. (1997) Pastagens extensivas do Sudoeste de la Península Ibérica: Producir mais conservando melhor. *Actas de la XXXVII Reunión Científica de la SEEP* (Sevilla-Huelva), pp. 163-182.
- Porqueddu C. and Maltoni S. (2005) Evaluation of a range of rainfed grass-legume mixtures in a Mediterranean environment. In: Dalmannsdóttir and Helgadóttir (eds) *Proceedings of COST 852 WG1 and WG2 Meeting*, Ystad, Sweden, Agricultural University of Iceland, p. 113.

# Botanical composition and stability of yield in legume/grass swards over eight years under grazing

Kadžiuilienė Ž. and Kadžiulis L.

*Lithuanian Institute of Agriculture, LT- 58344 Dotnuvos Akademija, Kėdainiai distr., Lithuania*

## Abstract

The stable balance between legumes and grasses in the swards, sustainable forage production within grazing season and over several years are still relevant objectives in grassland management. Different swards consisting of *Trifolium repens* L., *Medicago sativa* L., *Lolium perenne* L., *Poa pratensis* L., *Festulolium* hybrid in 1999-2006 were investigated under grazing management on a gleyic loamy *Cambisol*. The proportion of legumes in the legume/grass mixtures fluctuated both from year to year and within individual growth periods, and was very strongly influenced by environmental stress. The yield of legumes in the swards consisting lucerne after eight years of grazing accounted for nearly half and even more than half of the total sward yield. The content of white clover decreased more rapidly than content of lucerne. Among three functional groups (legumes, grasses and forbs), the persistence and competition of grasses with increasing sward age decreased. A positive effect of lucerne on stability of grazing swards was obtained over eight years. The yield distribution over grazing season in lucerne based swards was more even than that in grass or white clover/grass swards.

Keywords: lucerne, white clover, grasses, sward composition

## Introduction

The research needs to focus on the development of sustainable systems of production that are sufficiently resilient to maintain sward persistence and agricultural production under environmental stress (Rochon *et al.*, 2004). The main environmental factors affecting growth and herbage production are temperature, light and soil moisture (Hopkins, 2000).

The benefits of legume-based pastures cannot be assessed in terms of total DM productivity alone. White clover is the main legume to be found in pastures and meadows of temperate regions and is adapted to survive in a range of grassland environments (Frame *et al.*, 1998). Other legumes are of relatively little importance, such as lucerne, especially in grazed swards, because of low persistence and slow recovery of damaged plant parts. The proportion of white clover is unstable during the growing period, so that the resulting proportion of white clover in the mixture and its contribution to the herbivores' diet are still unpredictable (Rochon *et al.*, 2004).

The influence of mean temperature and cumulative day-degrees during different growth periods on the relative yields of white clover, red clover, lucerne, lotus and galega were analysed for different sites of Europe and showed that red clover and lucerne had high annual yield potentials. Across all sites, red and white clover showed the most stable yields. When comparing different legume species under similar site and environmental conditions, red clover and lucerne yielded about 2.5 t DM ha<sup>-1</sup> more than white clover and there was a significant impact of cumulative day-degrees during regrowth and the age of ley on the total annual yield. The persistence index (Halling *et al.*, 2004) was lowest for red clover and highest for lucerne. The objective of our experiment was to evaluate balance between legumes

and grasses, sustainability forage production within grazing season and over several years in different swards.

## Materials and methods

During 1998 – 2006 a randomized block design field trial of pasture utilization was carried out on a loamy *Endocalcari-Epihypogleyic Cambisol* near Dotnuva, Lithuania (55°24'N, 23°50' E, average annual rainfall 555 mm, average annual temperature 6° C, average length of growing season 194 days). The pasture was re-established in the spring of 1998 with an oat/vetch cover crop for green forage. Soil pH varied from 6.5 to 7.0, humus content was 2.5-3.2 %, available P 50-80 mg and K 100-150 mg kg<sup>-1</sup>. The treatments in four replicates involved different swards consisting of white clover (*Trifolium repens* L.) cv. Sudūviai, lucerne (*Medicago sativa* L.) cv. Birutė, perennial ryegrass (*Lolium perenne* L.) cv. Sodrė, meadow grass (*Poa pratensis* L.) cv. Lanka and *Festulolium* hybrid cv. Punia. Legume/grass proportion in the seeding mixtures was 40:60 (swards without lucerne) or 60:40 (swards containing lucerne). The grasses were also sown in pure stands and either fertilized with 240 kg N ha<sup>-1</sup> yr<sup>-1</sup> or given no fertiliser N. In spring and after first, second and third grazings nitrogen was applied at a rate 60 kg N ha<sup>-1</sup>. The grazing season lasted from the beginning of May until middle of October. Interval between two consecutive grazings lasted 25-40 days, four grazings per season. During 8 years of experiment climatic conditions differed to a great extent: grazing periods 2000, 2001, 2004 and 2005 were normal, 1999 wet, 2003 dry, and 2002 and 2006 very dry and warm. Stocking density was 2-2.5 dairy cows ha<sup>-1</sup> yr<sup>-1</sup>, grazing season duration 150 days. Before grazings half of each plot was cut for the dry matter (DM) yield determination. The DM yield data were statistically processed using analysis of variance.

## Results and discussion

The total annual dry matter yield was primarily affected by the climatic conditions and less by sward composition (Table 1 and Table 2). The swards responded differently to seasonal conditions. The DM yield in 2002, 2003 and 2006 was markedly lower than in all other years including 2005, i.e. 7<sup>th</sup> year of use. The yield of white clover in dry seasons declined more than that of lucerne and grasses or forbs. Only lucerne based swards had in all years a higher total and legume yield.

Table 1. Total dry matter annual yield of different swards and its persistence over eight years of use, t ha<sup>-1</sup>

Swards	1999	2000	2001	2002	2003	2004	2005	2006	8 yrs mean	Persistence index <sup>1)</sup>
<i>Trifolium repens</i> / <i>Lolium perenne</i>	6.12	5.49	5.02	2.58	2.69	5.26	4.74	2.74	4.33	0.64
<i>T. repens</i> / <i>L. perenne</i> / <i>Poa pratensis</i>	6.56	5.36	5.16	2.47	2.20	4.73	5.25	2.93	4.33	0.68
<i>Medicago sativa</i> / <i>L. perenne</i> / <i>P. pratensis</i>	7.55	8.87	7.19	3.04	5.59	8.63	8.24	4.52	6.70	0.78
<i>T. repens</i> / <i>M. sativa</i> / <i>L. perenne</i>	6.96	8.11	6.56	3.02	4.76	7.04	7.03	4.77	6.03	0.78
<i>L. perenne</i> /N <sub>0</sub>	3.23	4.45	4.73	3.12	2.31	4.38	5.21	3.13	3.82	1.09
<i>L. perenne</i> /N <sub>240</sub>	7.54	7.10	4.51	3.04	4.20	7.72	5.70	4.26	5.51	0.68
<i>T. repens</i> / <i>Festulolium</i> hybrid	6.74	6.21	5.36	2.60	2.53	4.97	4.76	2.94	4.51	0.59
LSD <sub>0,05</sub>	0.511	0.421	0.398	0.615	0.366	0.497	0.466	0.591	0.490	

Table 2. Legume annual dry matter yield of different swards and its persistence over eight years of use, t ha<sup>-1</sup>

Swards	1999	2000	2001	2002	2003	2004	2005	2006	8 yrs mean	Persistence index <sup>1)</sup>
<i>Trifolium repens/</i>	2.99	0.84	1.76	0.57	0.19	2.40	2.50	0.23	1.44	0.71
<i>Lolium perenne</i>										
<i>T. repens/L. perenne/</i>	3.48	1.10	2.13	0.74	0.19	2.00	2.58	0.20	1.55	0.61
<i>Poa pratensis</i>										
<i>Medicago sativa/</i>	5.25	5.92	4.69	1.58	4.04	6.56	5.42	2.97	4.55	0.75
<i>L. perenne/P. pratensis</i>										
<i>T. repens/M. sativa/</i>	4.04	2.71	3.58	1.63	3.04	4.32	3.74	2.91	3.25	0.99
<i>L. perenne</i>										
<i>T. repens/</i>	2.40	1.08	1.87	0.50	0.17	2.21	2.18	0.14	1.32	0.67
<i>Festulolium hybrid</i>										
LSD <sub>0.05</sub>	0.214	0.135	0.193	0.163	0.190	0.283	0.244	0.286	0.220	

<sup>1)</sup> Sward persistence index – last 2 years yield ratio to first 2 years

Table 3. Annual yield distribution over the grazing season: the DM yield in July-September ha<sup>-1</sup>, and its ratio to the yield in May-June

Swards		1999	2000	2001	2002	2003	2004	2005	2006	Mean
		Total DM yield (x) and ratio (y)								
<i>Trifolium repens/</i>	x	3.19	2.69	2.49	0.44	0.54	2.70	1.22	1.28	
<i>Lolium perenne</i>	y	1.09	0.97	0.98	0.21	0.25	1.05	0.35	0.88	0.72
<i>T. repens/L. perenne/</i>	x	3.52	2.65	2.65	0.54	0.41	2.52	1.33	1.57	
<i>Poa pratensis</i>	y	1.16	0.98	1.06	0.28	0.23	1.14	0.34	1.15	0.79
<i>Medicago sativa/</i>	x	4.81	4.38	3.75	1.08	2.58	4.78	2.95	2.02	
<i>L. perenne/P. pratensis</i>	y	1.76	0.98	1.09	0.55	0.86	1.24	0.56	0.81	0.96
<i>T. repens/M. sativa/</i>	x	3.83	4.19	3.61	1.01	2.08	3.62	2.34	2.30	
<i>L. perenne</i>	y	1.22	1.07	1.22	0.5	0.78	1.06	0.5	0.98	0.91
<i>L. perenne/N<sub>0</sub></i>	x	1.31	2.08	2.32	0.31	0.20	2.51	1.17	1.66	
	y	0.68	0.88	0.96	0.11	0.09	1.34	0.29	1.13	0.69
<i>L. perenne/N<sub>240</sub></i>	x	3.52	3.71	2.19	0.52	1.26	4.10	2.18	2.18	
	y	0.88	1.09	0.94	0.21	0.43	1.13	1.05	1.05	0.77
<i>T. repens/</i>	x	3.73	3.03	2.71	0.45	0.43	2.52	1.02	1.53	
<i>Festulolium hybrid</i>	y	1.24	0.95	1.02	0.21	0.20	1.02	0.27	1.09	0.75
		Legume DM yield (x) and ratio (y)								
<i>Trifolium repens/</i>	x	2.00	0.63	1.18	0.13	0.12	1.76	0.48	0.13	
<i>Lolium perenne</i>	y	2.02	3.00	2.03	0.3	1.71	2.75	0.24	1.30	1.27
<i>T. repens/L. perenne/</i>	x	2.20	0.75	1.53	0.25	0.1	1.46	0.56	0.08	
<i>Poa pratensis</i>	y	1.72	2.14	2.55	0.51	1.11	2.70	0.28	0.67	1.26
<i>Medicago sativa/</i>	x	3.90	3.01	2.87	0.93	2.28	3.99	2.09	1.26	
<i>L. perenne/P. pratensis</i>	y	2.89	1.03	1.58	1.43	1.30	1.55	0.63	0.74	1.26
<i>T. repens/M. sativa/</i>	x	2.70	1.77	2.53	0.84	1.91	2.69	1.50	1.34	
<i>L. perenne</i>	y	2.01	1.88	2.41	1.06	1.69	1.65	0.67	0.85	1.43
<i>T. repens/</i>	x	1.52	0.87	1.32	0.14	0.1	1.74	0.44	0.07	
<i>Festulolium hybrid</i>	y	1.73	4.14	2.40	0.39	1.43	3.70	0.25	2.00	1.42

Seasonal variation in the herbage yield complicates grazing management. Suitable legumes for grazing and their stable proportion in second half of the growing season (July-October) could support grazing in autumn and minimize supplementary feeding. The yield distribution over grazing season in lucerne based swards was more even than that in grass or white clover/grass swards (Table 3). Similar results were obtained in lucerne cultivars experiment in Dotnuva (Gutauskas and Petraityte, 2002). In our investigations the yield ratio between first and second half of grazing period was more favourable in lucerne/grass or white clover/lucerne/grass swards than in other swards. Legumes enabled a better distribution of yield over the grazing season than grasses or forbs. The use of nitrogen to perennial ryegrass

improved yield distribution within grazing season, but it was less beneficial comparing with lucerne based swards.

## **Conclusions**

Lucerne based swards had a higher total and legume yield and showed a positive effect on stability of grazing swards over eight years.

The legume DM yield of different swards fluctuated both from year to year and within individual growth periods, however legumes enabled a better distribution of yield over grazing season.

The use of nitrogen to perennial ryegrass improved yield distribution within grazing season, but yield ratio between first and second half of grazing period was more favourable in lucerne/grass and white clover/lucerne/grass swards.

## **References**

- Frame J., Charlton J.F.L. and Laidlaw A.S. (1998) Temperate Forage Legumes. Wallingford:CABI. 327 pp.
- Gutauskas J. and Petraityte E. (2002) Yield and quality of Lucerne cultivars in the cut or grazed swards *Grassland Science in Europe*,7, 420-421.
- Halling M.A., Topp C.F.E. and Doyle C.J. (2004) Aspects of the productivity of forage legumes in Northern Europe. (2004) *Grass and Forage Science*, 59, 331-344.
- Hopkins A. (2000) Grass: Its Production and Utilization. Blackwell Science, 440pp.
- Rochon J.J., Doyle C.J., Greef J.M., Hopkins A., Molle G., Sircia M., Scholefield D. and Smith C.J. (2004) Grazing legumes in Europe: a review of their status, management, benefits, research needs and future prospects. *Grass and Forage Science*, 59,197-214.



# The effect of the age of grassland on yield, botanical composition and nitrate content in the soil under grazing conditions

De Vliegheer A. and Carlier L.

*Institute for Agricultural and Fisheries Research ILVO, B-9820 Merelbeke, Belgium*

## Abstract

The aim of the experiment is to determine the effect of the age of grassland on productivity and quality of the sward under rotational grazing conditions. During five consecutive years the same grass-clover and grass mixture was sown in Merelbeke (1996 - 2000). The dry matter yield was measured until 2006. The first sowing year 1996 was the reference. The results 1997-2001 show that grassland renovation itself does not increase productivity when the botanical composition of the original sward is good. Renovation resulted in lower yields, mainly in the year of sowing and during the 2 following years. White clover developed very well; at the end it was dominating the sward and causing a drop in dry matter production and a considerable nitrate leaching risk.

Keywords: grassland renovation, yield, grass clover mixture

## Introduction

Grassland renovation is common practice in Flemish dairy farming. Application of a non-selective herbicide followed by ploughing, a good seed bed preparation and the use of a promising mixture is the normal procedure for grassland renovation in Flanders. Earlier studies from De Vliegheer et al. (1986) showed that in many cases direct drilling resulted in inferior sward development and a second grassland renovation. Data concerning the yield level of renovated grassland versus the yield level of an older pasture is rare. This results in an inadequate estimation of the economy of grassland renovation. In practice there is a tendency to think that in all circumstances renovated grassland would be more productive than the old sward. The advantage of grassland renovation can be attributed to an improvement in botanical composition, use of better varieties and/or the difference in yield potential between new and older grassland because of soil and sward characteristics. In this experiment the influence of the sward's age on productivity was examined for a perennial ryegrass and grass clover sward.

## Material and methods

The experiment was carried out on a sandy loam soil in Merelbeke. In September 1996, 2 mixtures were sown in a ploughed grass sward at 40 kg ha<sup>-1</sup>: (i) 50% tetraploid and 50% diploid *Lolium perenne* L. and (ii) a mixture of *Lolium perenne* L. (45%) *Festuca pratensis* Huds. (45%) and *Trifolium repens* L. (10%). Each year in September 1997- 2000 a strip of the sward sown in 1996 was ploughed and reseeded with the same mixtures including the same varieties. Both grass and grass clover swards were grazed separately by young bulls or heifers in a rotational grazing system with one cut in spring followed by approximately 5 grazing periods each 3 to 5 days. Nitrogen fertilisation was identical for all treatments: 330 kg N.ha<sup>-1</sup> for ryegrass sward and 170 kg N.ha<sup>-1</sup> for grass clover mixture. No slurry was applied. Just before mowing as well as before and after grazing 3 strips of 8.4 m<sup>2</sup> were cut in each treatment in order to calculate net grass yield. The quantity of white clover in the sward during the season was estimated by separating grass and clover from samples taken at the beginning of a grazing period. In autumn 2001 and 2004-2006 the botanical composition was evaluated and species scored in percentage of importance.

## Results and discussion

Compared to the sward sown in 1996 the annual renovation of a strip during the period 1997-2000 resulted in a decline in dry matter yield in the 10 year period: 5% (2-6%) on average for the ryegrass sward and 9% (6-11%) for the grass clover mixture (Table 1). This corresponds with an average loss of 0.5 ton DM ha<sup>-1</sup> year<sup>-1</sup> and 0.9 ton DM ha<sup>-1</sup> year<sup>-1</sup> for the grass and the grass clover sward respectively. Renovation of this pasture did not result in higher production levels for each of the 4 reseeding. There were, however, considerable losses in dry matter yield in the autumn of the sowing year and in the first and second year of the new sward..

Reseeding in September caused in the sowing year DM yield losses of 0.9 and 0.75 t ha<sup>-1</sup> for grass and grass clover respectively. In the first year after sowing the new grass sward yielded 1.6 t DM ha<sup>-1</sup> less than the reference sowing year 1996. For grass clover the difference ran to 3.2 t DM ha<sup>-1</sup>. It is obvious that the new swards sown in late autumn are not completely established. As a result the first cut is much lower in yield compared to the high yielding reference, especially in the grass clover sward: N- fertilization is reduced and white clover is only in installation phase and does not deliver any nitrogen for grass growth. In the second year after sowing the yield difference between reseeding and the reference was still approximately 1.5 and 1.4 t DM ha<sup>-1</sup> for the grass and grass clover sward. During the considered period 1996-2001 the sward of the grass reference -sowing 1996- contained almost exclusively the sown species *Lolium perenne* L.. This explains the high yield potential of the reference under this management regime during the reseeding phase of the other treatments. Reseeding such a pasture is not a practical issue but it illustrates that reseeding in itself does not increase yield.

Wolters (1972), Andries et al. (1981) and Mott and Ernst (1984) came to the same conclusion when the botanical composition of the old sward is of good quality. At least 60% of the grass species must be recognized as being of good quality (digestibility and intake) for ruminants. Schiltz et al. (2002) stated that grassland renovation is financially attractive when the new sward produces 10 to 25% more than the old sward. In Belgian conditions new grassland should produce 5-7% more than the 'old' one in order to compensate the costs (Nevens et al. 2002).

During the period 2001-2006 the reference sward is 5 to 10 years old. Even in this period the yield of the swards that are 1, 2 or 3 years younger is lower but not significantly different from the reference. Over a period of 10 years and in the last year the oldest sward was the highest in production in both grass and grass clover sward.

The botanical composition was periodically determined from November 2001 to 2006. Before 2001 it was clear that replacement of perennial ryegrass by indigenous grass species was negligible. In 2001, 2004 and 2005 ryegrass and white clover (in the grass clover pasture) were the dominating species within the sward. The importance of perennial ryegrass in the grass sward dropped from 74% in 2005 to 61% in November 2006 because *Poa* species had been developing in the sward. Differences in yield between the treatments were not related to their individual botanical composition. Although the drop in DM production of the grass clover sward in 2006 corresponds with a significant replacement of perennial ryegrass by *Poa* species (Table 2)

Even though sowing took place in late season, the establishment of white clover was satisfactory in almost all sowing years and developed well in the years after sowing, mainly due to the moderate nitrogen fertilization of 170 kg N ha<sup>-1</sup>. Meadow fescue (45 % of the mixture) did not persist so well and its presence after 5-10 years of renovation decreased to <5%. The average clover content in the summer period was about 30%, 40%, 37%, 25% and 23% respectively for the sowings that took place in 1996, 1997, 1998, 1999 and

Table 1. Influence of resowing grass and grass white clover mixtures on the nett dry matter yield under grazing during the period 1997-2006.

Grassland		Nett dry matter yield compared to nett dry matter yield of the sowing 1996										average	
type	harvest year	1997	1998	1999	2000	2001	2002	2003	2004	2005	2006	1997 - 2006	2001-2006
	sowing year.												
Grass	1996	100	100	100	100	100 <sup>a</sup>	100 <sup>a</sup>	100 <sup>a</sup>	100 <sup>ab</sup>	100 <sup>a</sup>	100 <sup>a</sup>	<b>100</b>	<b>100<sup>a</sup></b>
	1997	94 <sup>1</sup>	90 <sup>2</sup>	102	99	103 <sup>a</sup>	96 <sup>a</sup>	97 <sup>a</sup>	93 <sup>ab</sup>	103 <sup>a</sup>	98 <sup>ab</sup>	<b>98</b>	<b>98<sup>ab</sup></b>
	1998	(100)	96 <sup>1</sup>	92 <sup>2</sup>	85	95 <sup>ab</sup>	94 <sup>a</sup>	106 <sup>ab</sup>	91 <sup>a</sup>	98 <sup>ab</sup>	90 <sup>b</sup>	<b>94</b>	<b>95<sup>ab</sup></b>
	1999	(100)	(100)	91 <sup>1</sup>	82 <sup>2</sup>	91 <sup>ab</sup>	83 <sup>ab</sup>	101 <sup>a</sup>	105 <sup>b</sup>	101 <sup>a</sup>	99 <sup>a</sup>	<b>95</b>	<b>97<sup>ab</sup></b>
	2000	(100)	(100)	(100)	88 <sup>1</sup>	84 <sup>2b</sup>	74 <sup>b</sup>	118 <sup>ab</sup>	96 <sup>ab</sup>	91 <sup>ab</sup>	97 <sup>ab</sup>	<b>94</b>	<b>93<sup>b</sup></b>
100 = ... ..kg ha <sup>-1</sup>		9537	10326	9961	13418	12128	11427	11439	13138	12771	12885	<b>11703</b>	<b>12298</b>
Grass + Clover	1996	100	100	100	100	100 <sup>a</sup>	100 <sup>a</sup>	100 <sup>a</sup>	100 <sup>ab</sup>	100 <sup>a</sup>	100 <sup>a</sup>	<b>100</b>	<b>100<sup>a</sup></b>
	1997	98 <sup>1</sup>	54 <sup>2</sup>	85	111	100 <sup>a</sup>	108 <sup>ab</sup>	89 <sup>ac</sup>	94 <sup>ab</sup>	99 <sup>a</sup>	91 <sup>a</sup>	<b>93</b>	<b>97<sup>ab</sup></b>
	1998	(100)	95 <sup>1</sup>	73 <sup>2</sup>	105	105 <sup>a</sup>	102 <sup>ab</sup>	72 <sup>c</sup>	77 <sup>c</sup>	81 <sup>ab</sup>	85 <sup>ab</sup>	<b>89</b>	<b>86<sup>d</sup></b>
	1999	(100)	(100)	94 <sup>1</sup>	76 <sup>2</sup>	71 <sup>b</sup>	111 <sup>b</sup>	85 <sup>ac</sup>	89 <sup>b</sup>	86 <sup>ab</sup>	91 <sup>ab</sup>	<b>90</b>	<b>89<sup>cd</sup></b>
	2000	(100)	(100)	(100)	86 <sup>1</sup>	83 <sup>2b</sup>	89 <sup>b</sup>	109 <sup>b</sup>	94 <sup>ab</sup>	91 <sup>ab</sup>	93 <sup>ab</sup>	<b>94</b>	<b>94<sup>bc</sup></b>
100 = ... ..kg ha <sup>-1</sup>		8416	10491	11588	11817	10803	11196	12639	13421	10721	9544	<b>11064</b>	<b>11387</b>

<sup>(1)</sup>: nett yield of sowing up to the sowing date

<sup>(2)</sup>: nett yield in first year after sowing

Table 2. Botanical composition of the grass and grass clover swards in % of importance (average of the treatments)

Year of determination	Grass				Grass clover			
	Lolium perenne	other grasses	white clover	Herbs, weeds	Lolium perenne	other grasses	white clover	Herbs, weeds
2001	93 (85-98) <sup>(1)</sup>	2 (0-5)	2 (0-8)	2 (1-4)	67 (60-73)	4 (1-9)	26 (20-30)	4 (2-6)
2004	76 (66-89)	12 (6-16)	4 (0-11)	8 (0-19)	35 (22-48)	18 (10-30)	43 (39-48)	4 (1-9)
2005	73 (65-85)	11 (0-19)	6 (0-15)	10 (5-14)	43 (39-52)	35 (22-46)	19 (11-26)	3 (1-6)
2006	61 (53-80)	38 (17-50)	1 (0-3)	0 (0-0) <sup>(2)</sup>	22 (18-31)	51 (40-68)	26 (12-39)	1 (0-3) <sup>(2)</sup>

<sup>(1)</sup>: average (minimum- maximum)

<sup>(2)</sup>: herbicide treatment in autumn

2000. The clover percentage in the sward varied not only during the grazing season (low in spring, high in summer and moderate in autumn) but also from year to year. Compared to 2005 (19%) clover development was significantly higher in 2004 (67%). Managing a good clover part in a grass clover sward is not easy and depends on a multitude of factors, especially the weather conditions.

Depending on weather conditions (repartition of the precipitation, temperature and sunshine) and management conditions the yield of the grass sward varies from one year to another. This also influences nitrate content in the soil after grazing season. The nitrate Council Directive 91/676/EEC is one of the 19 cross compliances the farmer needs to fulfil in order to obtain his single EU payment (Council Regulation (EC) No 1782/2003). In Flanders this Directive has been “translated” into a limitation of the  $\text{NO}_3\text{-N}$  content after harvest to 90 kg/ha in the soil layer 0-90 cm. Even though the grass-clover sward was fertilized with half the quantity of mineral nitrogen compared to the grass sward  $\text{NO}_3\text{-N}$  content in the soil after the grazing season was on average the same (72 kg versus 67 kg) and so was the risk at passing the barrier of 90 kg  $\text{NO}_3\text{-N ha}^{-1}$  (22% in both cases). Within the grass and grass clover pasture there was a variation in nitrate content in the soil between sowing years but this was not related to the age of the grassland. In 2006 the nitrate content on the grass clover swards was high (144 kg N  $\text{ha}^{-1}$ ). A lower nett grass yield compared to the grass pasture, a very high clover content in the dry matter, a long grazing season and high temperatures in October and November could explain this. White clover not only “fertilises” the accompanied grass, but may also result in high residual nitrate content in the soil.

## Conclusion

In this experiment the yield of a 5 to 10 years old pasture - ryegrass or grass clover - was better than the yield of a renovated pasture because the botanical composition was almost identical and grassland renovation caused dry matter yield losses in autumn of the sowing year and during the next consecutive 2 years. It is better to manage “old” or “permanent” grassland with a good botanical composition in a good way rather than renovate it. White clover was really dominating the sward at the end of this experiment under grazing conditions and there was a considerable risk at nitrate leaching.

## References

- Andries A., Behaeghe T., Toussaint B. and Carlier L. (1981) Exploitation des prairies. 1. Amélioration et resemis des prairies. *Revue de l'Agriculture* 34, 3, 469-478.
- De Vliegheer A., Carlier L., Coolen W. and Hendrickx G. (1986) Problems with direct drilling of grassland. *Proceedings of the 11<sup>th</sup> Gen. meeting of the EGF*. “Grassland facing the energy crisis” 207-211. Trioa, Stubal, Portugal. Ed. F.M. Borba and L.M. Abreu
- Nevens F., Verbruggen I., De Vliegheer A. and Reheul D. (2002) Ecological, environmental and economic aspects of grassland cultivation in Belgium. In *Grassland resowing and grass arable crop rotations. EGF Working Group report 1*, 25-32.
- Schils R., Aarts F., Bussink D., Conijn J., Corré W., van Dam A., Hoving I., van der Meer H. and Velthof G. (2002) Grassland renovation in the Netherlands: agronomics, environmental and economic issues In *Grassland resowing and grass arable crop rotations. EGF Working Group report 1*, 25-32.
- Mott N. and Ernst P. (1984) Grünlandverbesserung - Nachsaat - Neuansaat In Hrsg.: Auswertungs- und Informationssdienst für Ernährung, Landwirtschaft und Forsten.
- Woldring J. (1975) Invloed van de herinzaai en stikstof op de opbrengst en de botanische samenstelling van grasland. Proefstation voor Rundveehouderij. Rapport, 35, 20 pp.

# Meadow fescue or smooth meadow grass for cutting and grazing

Nesheim L.

*Norwegian Institute for Agricultural and Environmental Research, Grassland and Landscape Division, Kvithamar, N-7500 Stjordal, Norway*

## Abstract

In most regions of Norway perennial ryegrass (*Lolium perenne*) does not have sufficient winter hardiness to survive the winters. Timothy (*Phleum pratense*) is the most common sown species in Norwegian grassland. The persistence is far better than for perennial ryegrass, but timothy is not particularly well suited for grazing and semi-permanent grassland. Therefore, there is a need for varieties of other species, which are high yielding, persistent and well suited both for cutting and grazing in temporary and semi-permanent grassland. In the years 2000 and 2001 three varieties and one cultivar of meadow fescue (*Festuca pratensis*) and four varieties of smooth meadow grass (*Poa pratensis*) were sown on experimental plots at 17 sites all over Norway. The harvest regime was either cutting (2-3 cuts) or simulated grazing (4-5 harvests). The experiments were harvested for three years. The varieties of smooth meadow grass established much slower than the varieties of meadow fescue, resulting in lower DM yield, particularly in the first year of ley, both in the grazing and cutting regime. The forage quality was about similar for both species. In the third year there were no significant yield differences between the species, and the proportion of sown species was also quite similar.

Keywords: *Festuca pratensis*, forage quality, persistence, *Poa pratensis*

## Introduction

Most meadows in Norway are sown with a mixture of Norwegian varieties of timothy (*Phleum pratense*), meadow fescue (*Festuca pratensis*) and red clover (*Trifolium pratense*). Foreign varieties of perennial ryegrass (*Lolium perenne*) are grown to some extent at the Western coast. This species is well suited for frequent cutting and grazing, the forage quality is high, but the winter persistence is often not satisfactory under Norwegian conditions. The persistence of timothy is far better than for perennial ryegrass, but timothy is not particularly well suited for grazing and semi-permanent grassland. Therefore, there is a need for cultivars of other species, which are high yielding, persistent and well suited both for cutting and grazing in temporary and semi-permanent grassland. The objective of the present work was to investigate the production, quality and persistence of four varieties of each of the species meadow fescue and smooth meadow grass (*Poa pratensis*) at different sites. The harvest regime was either cutting (2-3 cuts) or simulated grazing (4-5 harvests).

## Materials and methods

An experiment was conducted with two replicates of eight varieties distributed at random on small plots (1.5 m x 7.0 m), in one block of 16 plots for the cutting regime and in one block for simulated grazing. The varieties of meadow fescue (all Norwegian) were: 'Salten', 'Fure', 'Hugin' (a cultivar, not included in The Norwegian Official List of Varieties) and 'Norild'. The varieties of smooth meadow grass were: 'Oxford' (British), 'Monopoly' (Dutch), 'Entopper' (Dutch) and 'Knut' (Norwegian).

The experiment was established at 17 sites in 2001 and 2002. Four trials were located in Eastern Norway with a continental climate (400-900 mm precipitation year<sup>-1</sup>), three fields were situated at the Western coast (precipitation > 1000 mm year<sup>-1</sup>, mild winters), five trials were located in Central Norway and five fields in Northern Norway, where the precipitation varies from about 500 mm inland to more than 1500 mm at the coast, and the winter conditions may be very variable.

The experimental fields were fertilised with compound fertiliser according to common practise in the region. The first of 2-3 cuts (number of cuts depended on the length of growing season) was taken at heading of meadow fescue. On the simulated grazing regime the plots were harvested for the first time when sward height of smooth meadow grass was about 15 cm. Thereafter the plots were harvested every 4-5 weeks. The proportion of sown species was assessed visually as per cent of DM yield at each harvest. In the first year of the ley dried samples were analysed for forage quality using Near Infrared Reflectance Spectroscopy (NIRS) (Fystro and Lunnan 2006). The content of crude protein (CP) was calculated as Kjeldahl N × 6.25, and a measure of energy concentration (feed units (FU) per kg of DM) was determined according to Lunnan and Marum (1994). The trials were harvested for three years.

## Results and discussion

The varieties of meadow fescue established much better than the smooth meadow grass varieties, which resulted in significantly higher proportions of sown grasses for meadow fescue in the first year, both in the cutting and the grazing system (Table 1 and 2). In the second and third year the proportion of sown grasses was quite similar in both regimes for the two species, but there were some differences between the varieties. After three years the per cent sown grasses was significantly higher for the Norwegian variety 'Knut' than for 'Entopper' in the cutting system, but not in the simulated grazing system. Grazing did not result in lower persistence of either species, however, the proportions of smooth meadow grass were somewhat higher in the third year after grazing compared to the cutting system.

Table 1: Cutting regime: Percent sown grass species at the second cut and total DM yield of 2-3 cuts in tons ha<sup>-1</sup>

Species/variety	1 <sup>st</sup> year of ley		2 <sup>nd</sup> year of ley		3 <sup>rd</sup> year of ley	
	% grass 2 <sup>nd</sup> cut	Total DM yield	% grass 2 <sup>nd</sup> cut	Total DM yield	% grass 2 <sup>nd</sup> cut	Total DM yield
Meadow fescue:						
Salten	84a	9.60a	70	9.95	67ab	9.45
Fure	83a	9.90a	71	9.96	72a	9.28
Hugin	83a	9.56a	63	9.79	60ab	9.41
Norild	88a	10.09a	79	10.09	74a	9.47
Smooth meadow grass:						
Oxford	56b	8.33b	61	9.77	62ab	9.88
Monopoly	57b	8.22b	59	9.76	65ab	9.89
Entopper	50b	8.01b	58	9.12	56b	9.32
Knut	60b	8.00b	65	9.59	73a	9.93

Average of 17 trials in the first year, 15 trials in the second year and 13 trials in the third year. Means marked with different letters were significantly different ( $P < 0.05$ ) according to a Ryan-Einot-Gabriel-Welsch multiple-range test.

The dry matter yields were significantly higher for meadow fescue than for smooth meadow grass in the first year (Table 1 and 2). In the following two years the yield was quite similar. There were no yield differences between varieties of the same species in any of the years. For both species the mean DM yield of three years was about 2.2 tons higher per hectare on the cutting system than on the simulated grazing regime. Because the feed quality was analysed only the first year, it is not possible to estimate the mean yield of feed units for the whole experimental period. But in the first year the total yield of feed units on the simulated grazing system was 85% of the corresponding yield on the cutting system, compared to 77% based on dry matter yield.

Table 2: Simulated grazing regime: Percent sown grass species at the third harvest and total DM yield of 4-5 harvests in tons ha<sup>-1</sup>

Species/variety	1 <sup>st</sup> year of ley		2 <sup>nd</sup> year of ley		3 <sup>rd</sup> year of ley	
	% grass 3 <sup>rd</sup> harv.	Total DM yield	% grass 3 <sup>rd</sup> harv.	Total DM yield	% grass 3 <sup>rd</sup> harv.	Total DM yield
Meadow fescue:						
Salten	81a	7.14b	88ab	7.87	70bc	6.30b
Fure	85a	7.71ab	86abc	8.05	69bc	6.54ab
Hugin	84a	7.67ab	83abc	7.88	64c	6.49ab
Norild	86a	8.15a	91a	8.09	74abc	6.55ab
Smooth meadow grass:						
Oxford	61b	6.02c	75bc	7.81	83ab	6.73ab
Monopoly	61b	6.14bc	80abc	7.93	84ab	6.99a
Entopper	59b	6.09bc	73c	7.69	80ab	6.50ab
Knut	62b	6.22bc	81abc	8.17	85a	7.00a

Average of 16 trials in the first year, 14 trials in the second year and 13 trials in the third year. Means marked with different letters were significantly different ( $P < 0.05$ ) according to a Ryan-Einot-Gabriel-Welsch multiple-range test.

At the first cut of the cutting regime there were only small differences in feed quality parameters between the two species (Table 3). The varieties of meadow fescue had a slightly lower content of crude protein and WSC, and a higher content of fibre (NDF) than the smooth meadow grass varieties.

Table 3: Cutting regime: Feed units kg<sup>-1</sup> DM (FEm), *in vitro* digestibility of dry matter (IVDDM), content of crude protein, neutral detergent fibre (NDF) and water-soluble carbohydrates (WSC) as % of DM at the first cut in the first year of ley

Species/variety	FEm	IVDDM	Crude protein	NDF	WSC
Meadow fescue:					
Salten	0.84ab	70.3	12.8ab	58.8ab	14.9bc
Fure	0.83b	69.7	12.6b	59.1a	15.0abc
Hugin	0.84ab	70.0	13.4ab	58.2abc	14.5c
Norild	0.84ab	70.5	12.7ab	58.4abc	15.3abc
Smooth meadow grass:					
Oxford	0.85ab	70.9	13.3ab	55.7cd	16.9ab
Monopoly	0.85ab	70.4	13.4ab	56.8abcd	15.5abc
Entopper	0.85ab	70.1	13.9a	56.1bcd	14.8bc
Knut	0.87a	71.5	13.7ab	55.2d	17.3a

Average of 15 trials. Means marked with different letters were significantly different ( $P < 0.05$ ) according to a Ryan-Einot-Gabriel-Welsch multiple-range test.

Parameters of feed quality at the first harvest in the grazing system are presented in Table 4. The *in vitro* digestibility of smooth meadow grass was significantly lower than for meadow fescue. The differences in feed units per kg DM were smaller between the two species.

However, in later harvests in the first year (data not presented) the feed unit concentration of smooth meadow grass varieties was significantly lower than in the varieties of meadow fescue. Concerning the content of crude protein, fibre (NDF) and WSC the differences between varieties were small.

Table 4: Simulated grazing regime: Feed units  $\text{kg}^{-1}$  DM (FEm), *in vitro* digestibility of dry matter (IVDDM), content of crude protein, neutral detergent fibre (NDF) and water-soluble carbohydrates (WSC) as % of DM at the first harvest in the first year of ley

Species/variety	FEm	IVDDM	Crude protein	NDF	WSC
Meadow fescue:					
Salten	0.98a	79.4a	14.7abc	48.8	22.1ab
Fure	0.97ab	79.1a	14.3bc	49.6	21.4ab
Hugin	0.96 abc	78.7a	14.9abc	49.7	20.9b
Norild	0.96abc	79.1a	14.0c	50.0	21.5ab
Smooth meadow grass:					
Oxford	0.95cd	76.3b	14.7abc	49.2	23.6a
Monopoly	0.94d	76.1b	15.5a	50.0	20.4b
Entopper	0.95bcd	76.8b	15.6a	47.9	21.4ab
Knut	0.95 abcd	76.9b	15.2ab	48.1	23.6a

Average of 15 trials. Means marked with different letters were significantly different ( $P < 0.05$ ) according to a Ryan-Einot-Gabriel-Welsch multiple-range test.

## Conclusions

The smooth meadow grass did establish much slower than meadow fescue, resulting in lower DM yields in the first year of ley. But in later years the varieties of smooth meadow grass produced as much dry matter as the varieties of meadow fescue, and the persistence was at the same level, or even better after three years of simulated grazing. Concerning forage quality the differences between the two species were quite small, but the *in vitro* digestibility and the feed unit concentration were slightly lower for the varieties of smooth meadow grass in the first year (forage quality parameters were only analysed in year one).

## References

- Fystro G. and Lunnan T. (2006) Analysar av grovførkvalitet på NIRS. (In Norwegian). *FOKUS*, 1 (3): 180-181.  
 Lunnan T. and Marum P. (1994) Timothy varieties for upland areas in southern Norway. Response to nitrogen fertilizer on yield and quality. (In Norwegian). *Norsk Landbruksforskning*, 8, 305-314.



## Productivity and persistency of *Festulolium* and *Lolium x boucheanum* swards

Gutmane I. and Adamovich A.

Latvia University of Agriculture, 2 Liela iela, Jelgava, LV-3001, Latvia

### Abstracts

The objective of this research was to investigate crop yield and sward persistency of *Festulolium* and *Lolium x boucheanum* varieties under agro-ecological conditions of Latvia. Field trials were established on sod-podzolic soil and fertilization rates were 120 (60+60) kg N ha<sup>-1</sup> or 180 (60+60+60) kg N ha<sup>-1</sup>, 78 kg P<sub>2</sub>O<sub>5</sub> and 90 kg K<sub>2</sub>O ha<sup>-1</sup>. The swards were harvested three times during the growing season. On the basis of the experiments in the years 2003-2006, significant differences in DM yield and winter hardiness were found between first, second and third year of yielding. Longevity of *Festulolium* swards were affected by different reasons, such as suitability of each variety to specific conditions, different stress conditions, and fertilization regime. The maximum yield was obtained in the 1st year of sward use at both N treatments. On average, the N fertilizer dose increase to 180 kg ha<sup>-1</sup> contributed to a DM yield increase by 15%. The research results showed a substantial decrease in DM yield (by 17%) already between first and second year of yielding. Differences between varieties in DM yield were highly significant and exhibited a similar tendency during the three harvest years.

Key words: *Festulolium*, *Lolium x boucheanum*, productivity, persistency

### Introduction

Under conditions of Latvia's climate, forage grasses are the main fodder source in cattle breeding. The increasing requirement for sustainable agricultural grassland is extended growing seasons, combined with good winter survival to ensure sward longevity (Harrison *et al.*, 1997). The level of the productivity and stability mostly depends on the genetic potential of the forage grass species. Unfortunately, grass species that offer best winter survival are frequently inferior to grass species used in agriculture as a source of high-quality digestible fodder for grazing animals.

High-quality forage *Lolium* has been bred for intensive systems in benign environments and has proved to be insufficiently robust to meet many of the environmental challenges in more extreme conditions (Humphreys, 2002). Hybrid ryegrass (*Lolium x boucheanum*) is less winterhardy but higher yielding than perennial ryegrass. In Baltic climate conditions it is not widely used for the reason of unsatisfactory response to cold conditions (Gutmane and Adamovics, 2004). Sometimes crops considerably suffer even in the first winter, which decreases their productivity (Nekrošas, 2002).

However, developing forage grasses with potential for extended growth in the autumn and spring may be achieved by hybridization between the more desirable species and native winterhardy closely related species (Eagles and Fuller, 1982). *Festulolium* hybrids are among the most persistent and productive grasses used in many European countries, especially in adverse environments (Kohoutek *et al.*, 2004). An important requirement for *Festulolium* is combining ryegrass characters as productivity, growth potential and feeding quality, and fescue characters as winterhardiness and resistance to drought during the growing period (Casler *et al.*, 2002).

## Materials and methods

Field trials were conducted in Latvia on sod-podzolic soils, with pH 7.1. The level of phosphorus and potassium was 253 and 198 mg kg<sup>-1</sup>, respectively, and organic matter content 31g kg<sup>-1</sup>. The swards were composed of: perennial ryegrass ‘Spidola’ (control); *Festulolium* ‘Perun’ (*L. multiflorum* x *F. pratensis*), ‘Punia’ (*L. multiflorum* x *F. pratensis*), ‘Saikava’ (*L. perenne* x *F. pratensis*), ‘Lofa’ (*L. multiflorum* x *F. arundinacea*), ‘Felina’ (*L. multiflorum* x *F. arundinacea*), ‘Hykor’ (*L. multiflorum* x *F. arundinacea*); and hybrid ryegrass ‘Tapirus’ (*L. multiflorum* x *L. perenne*). Sward plots were arranged in May 2002 and 2003 without cover crop, seeding rate was 1000 germinating seeds per m<sup>-2</sup>. The plots were fertilized as follows: P 78 and K 90 kg ha<sup>-1</sup>, and two N fertilizer treatments – N 120<sub>(40+40+40)</sub> and N 180<sub>(60+60+60)</sub>. Swards were cut three times per season. The experimental data were subjected to ANOVA analysis and to correlation and regression analyses.

Meteorological conditions were different in winter and vegetation periods. In 2003, a black frost during a cold winter and a hot July and first part of August were followed by mild temperatures and rainfalls. The mild winter and dry and cool spring in 2004 were followed by a cool and wet summer. The early snow cover without frost contributed to snow mildew formation in the winter of 2004/2005. The year 2005 was characterized by a late and cool spring and hot and dry July. The cold and long winter with good snow cover in 2006 was followed by an extremely hot and dry summer.

## Results and discussion

On the basis of the experiments in the years 2003-2006, significant differences in DM yield and winter hardiness were found between first, second, and third harvest year. Longevity of *festulolium* swards were affected by different reasons, such as suitability of each variety to specific conditions, different stress conditions, and using regime. *Festulolium* hybrids and especially perennial ryegrass often are insufficiently resistant to winter conditions. The analysis of the data showed a substantial decrease in winter hardiness during the harvest years (Table 1).

Table 1. Winter hardiness (score 1-9s) during years of sward use

Sowing year	Year of sward use (F <sub>C</sub> )	Nitrogen levels, kg ha <sup>-1</sup> (F <sub>B</sub> )	Varieties (F <sub>A</sub> )							
			Spidola	Lofa	Felina	Saikava	Hykor	Perun	Tapirus	Punia
2002	first	N120	7.8	6.5	7.5	x	7.0	7.5	6.8	8.0
		N180	7.8	6.5	7.5	x	7.0	7.5	6.8	8.0
	second	N120	7.8	7.3	7.8	x	7.8	7.5	7.5	8.0
		N180	8.0	7.5	8.0	x	7.8	7.5	7.5	8.0
	third	N120	6.3	5.3	7.0	x	7.0	5.8	5.5	6.5
		N180	6.3	5.3	6.8	x	7.3	6.0	5.5	6.
LSD <sub>0.05</sub> F <sub>A</sub> = 0.34; F <sub>B</sub> = 0.18; F <sub>C</sub> = 0.22; F <sub>AB</sub> = 0.48; F <sub>AC</sub> = 0.59; F <sub>BC</sub> = 0.31										
2003	first	N120	7.8	7.8	x	8.0	7.8	7.8	8.0	8.3
		N180	7.8	7.8	x	8.0	7.8	7.8	8.	8.3
	second	N120	6.	6.0	x	6.8	6.5	6.5	6.0	7.0
		N180	6.5	5.5	x	6.3	6.5	6.0	5.8	6.8
	third	N120	4.0	2.8	x	4.5	5.3	3.8	3.5	5.0
		N180	4.8	2.5	x	5.3	5.3	4.0	3.0	5.0
LSD <sub>0.05</sub> F <sub>A</sub> = 0.32; F <sub>B</sub> = 0.17; F <sub>C</sub> = 0.21; F <sub>AB</sub> = 0.45; F <sub>AC</sub> = 0.56; F <sub>BC</sub> = 0.30										

The weather condition in the 2004/2005 winter contributed to snow mildew formation on *Festulolium* and hybrid ryegrass swards. Both *Festulolium* cultivars ‘Hykor’ and ‘Felina’ demonstrated the highest resistance against snow mildew. A significant correlation between winter hardiness ( $r = -0,99$  with  $P\text{-value} < 0.05$ ) and resistance against snow mildew was observed in the year 2005.

The great effect of the sward utilization year on the dry matter yield of *Festulolium* hybrids and especially *Lolium perenne* has been mentioned in the literature. In Lithuania, dry matter yield of *Festulolium* hybrids declined over 30 % in the second year of sward use (Lemežiene, 2004). Our results show a substantial decrease in DM yield even between first and second harvest year, which was different for two sowing years. The average DM yield distribution over the years showed significant differences. The maximum yield was obtained in the first year of sward use in both sowing years.

For the sowing year 2002, maximum yield differences were observed between the second and third year of sward use. Whereas for the sowing year 2003, maximum yield differences were observed between the first and second year of sward use, which corresponds to the year 2005 when snow mildew formation and bad humidity conditions for the sward during spring and summer were observed.

Perennial ryegrass, hybrid ryegrass, and *Festulolium* are grasses that require high nitrogen fertilisation when grown for high dry matter yields.

The DM yield was influenced substantially by both – the used variety as well as by nitrogen fertilization rate (Table 2).

Table 2. DM yield ( $t\ ha^{-1}$ , three years of sward use) at two N application levels

Sowing year	Year of sward use ( $F_C$ )	Nitrogen levels, $kg\ ha^{-1}$ ( $F_B$ )	Varieties ( $F_A$ )							
			Spidola	Lofa	Felina	Saikava	Hykor	Perun	Tapirus	Punia
2002	first	N120	11.09	14.30	15.96	x	17.55	16.61	13.43	16.58
		N180	12.91	15.73	16.85	x	18.88	18.46	15.07	18.46
	second	N120	8.64	12.03	12.64	x	16.13	12.05	11.15	12.,04
		N180	10.05	13.47	14.88	x	17.38	14.54	13.80	14.48
	third	N120	4.61	6.59	8.49	x	9.13	7.25	5.81	6.76
		N180	5.48	6.38	10.02	x	11.04	7.70	6.48	7.77
LSD <sub>0.05</sub> for DM yield: $F_A= 0.39$ ; $F_B= 0.21$ ; $F_C= 0.26$ ; $F_{AB}= 0.56$ ; $F_{AC}= 0.68$ ; $F_{BC}= 0.36$										
2003	first	N120	7.56	12.94	x	11.34	13.52	13.58	12.21	13.65
		N180	10.96	16.13	x	16.06	16.28	17.57	16.61	17.88
	second	N120	4.78	5.88	x	5.,96	9.31	6.85	5.94	7.12
		N180	5.34	7.26	x	7.68	11.87	9.21	7.31	9.71
	third	N120	3.57	5.81	x	4.93	10.15	5.43	4.37	5.53
		N180	4.99	6.48	x	6.33	10.78	7.33	6.25	6.70
LSD <sub>0.05</sub> $F_A= 0.37$ ; $F_B= 0.20$ ; $F_C= 0.24$ ; $F_{AB}= 0.52$ ; $F_{AC}= 0.64$ ; $F_{BC}= 0.34$										

The N fertilizer dose increase from 120 to 180  $kg\ ha^{-1}$  contributed to a significant DM yield increase for all investigated varieties. On average, the N fertilizer dose increase to 180  $kg\ ha^{-1}$  contributed to DM yield increase by 1.91  $t\ ha^{-1}$  or 20 percent.

The positive effect of increased nitrogen rates was more expressed on loloid *Festulolium* cultivars in the first year of yielding, than of festucoid *Festulolium* cultivars. In the second and third year of yielding, differences in the positive effect of increased nitrogen rates between loloid and festucoid *Festulolium* cultivars were not observed.

Comparing the factor (variety and N fertilizer rate) effect on DM yield, considerable differences were observed during the years of sward use. In the first year of sward use, N fertilizer rate showed the highest effect on DM yield – 78 and 44 %. In the second and third

year of sward use, the effect of N fertilizer amount decreased to 18 and 20 %. Whereas the effect of the variety increased over the years of sward use and was the highest in the third year – 82 and 75%.

The highest average DM yield during three yielding years was provided by festucoid type *Festulolium* cultivars ‘Hykor’ and ‘Felina’ – 13.14 and 13.50 t ha<sup>-1</sup>, respectively. Differences between varieties in DM yield were highly significant and exhibited similar tendency during the three harvest years. Both festucoid *Festulolium* cultivars provided the highest yield in all years of sward use. The average DM yield of *Festulolium* cultivars was by 3.99 t ha<sup>-1</sup> or 53 % higher, but those of hybrid ryegrass by 2.37 t ha<sup>-1</sup> or 32 % higher than perennial ryegrass.

## Conclusions

Significant differences in the *Festulolium* and *Lolium x boucheanum* DM yield and winter hardiness were found between first, second, and third year of yielding.

The biomass productivity depended on the used cultivar and the nitrogen fertilization rates.

Cultivars of ‘*Festulolium*’ and ‘*Lolium x boucheanum*’ are promising species to be used as fodder grasses in the climatic zone of Latvia.

## References

- Casler M. (2002) Natural selection for survival improves freezing tolerance, forage yield and persistence of *Festulolium*. *Crop Science*, 42, 1421-1426.
- Gutmane I. and Adamovich A. (2004) Productivity and yield quality of *Festulolium* and *Lolium x boucheanum* varieties. *EGF, Grassland Science in Europe*, 9, 428 – 430.
- Eagles C.F. and Fuller M.P. (1982) Evaluation of cold hardiness in forage grass and legumes. In: M.D.Hayward (eds) *The Utilization of Genetic Resources in Fodder Crop Breeding Proceedings Eucarpia Fodder crop section meeting*, Aberystwyth, 172 – 184.
- Harrison J., Tonkinson C., Eagles C. and Foyer C. (1997) Acclimation to freezing temperatures in perennial ryegrass (*Lolium perenne*). *Acta Physiologiae Plantarum*, 505-515.
- Humphreys J., Tomas H.M., Jones N. and Humphreys M. (2002) Sustainable grasslands withstanding environmental stress (SAGES). *EGF, Grassland Science in Europe*, 7, 310 - 311.
- Lemežiene N., Kanapeckas J., Tarakanovas P. and Nekrošas S. (2004) Analysis of dry matter yield structure of forage grasses. *Plant, Soil and Environment*, 50 (6), 277 - 282.
- Kohoutek A., Odstrčilová V., Komarek P., Nerušil P. (2004) Persistence and production ability of *Dactylis glomerata* L., *Dactylis polygama* Horvat, *Festuca arundinacea* L. and genus hybrids in 1986-2003. *EGF, Grassland Science in Europe*, 9, 422 – 424.
- Nekrošas S. and Sliesaravičius A. (2002) Investigation of intergeneric ryegrass-fescue and inerspecific ryegrass hybrids developed in Lithuania. *Žemdirbyste. Mokslo darbai*. LŽI. Dotnuva-Akademija, t. 78, 158 - 163.

# Productivity of grasslands in the Province of Warmia and Mazury

Grzegorz S. and Grabowski K.

*University of Warmia and Mazury in Olsztyn, Department of Grassland, Poland*

## Abstract

Statistical data concerning the area covered by grasslands as well as the populations of cattle and sheep were analyzed in the study. Plant species that dominate in the grasslands located in the Province of Warmia and Mazury were determined based on an evaluation of species composition in over 200 communities. Grassland occupies a larger area in the Province of Warmia and Mazury, compared to the entire territory of Poland, so cattle density is also higher in this region. Meadow communities show high biodiversity. The productivity of permanent grassland is low, primarily due to unregulated water regimes, irrational farming practices and insufficient fertilization.

Keywords: grassland, arable land

## Introduction

Grassland farming is inseparably linked with animal production (Mannetje and Paoletti, 1992, Wright, 2005). Meadows and pastures provide inexpensive, palatable, high-quality fodder for both farm animals and wild ruminants (deer family). Green forage characterized by good botanical composition may be the only source of feed for animals, including high-performance ones. Diets for ruminants should be based on green crops, since the proportion of green forage, hay or haylage in the ration has a significantly effect on the overall profitability of animal production. The spatial distribution of permanent grasslands in Poland is highly uneven. They are often located in river valleys, where groundwater levels are relatively high and regular flooding provides the nutrients essential for grass growth. Grasslands are also commonly found in the northern part of Poland as well as in mountain areas which have more abundant precipitation. The aim of this study was to present the current state of permanent grassland in the region of Warmia and Mazury.

## Materials and methods

Statistical data concerning the area covered by grasslands as well as the populations of cattle and sheep were analyzed in the study. Plant species that dominate in the grasslands located in the Province of Warmia and Mazury were determined based on an evaluation of species composition in over 200 communities.

The Province of Warmia and Mazury is a unit of the administrative division of Poland. It is situated in the north-eastern part of the country, in the Masurian Lakeland known for its diversified relief. There are numerous heights, hills, plains and high-gradients rivers and streams cutting through valleys in this area. Another distinguishing feature of the local landscape is the presence of forests, lakes and peatlands. As regards the climate conditions, the temperature range is wide, precipitation distribution is generally unfavorable, ground frosts occur in late spring and early fall, and weather changes quite rapidly. Insolation is rather low, since the number of cloudy days per year may be as high as 170. The winds are strong and frequent. The growing season lasts shorter than in the other parts of Poland, i.e.

from 180 to 190 days, whereas the length of the grazing season is 175 to 180 days. There are considerable differences between mean annual and monthly temperatures, as well as between precipitations totals. Despite a relatively high rainfall amount (550-600 mm), soil moisture deficiency is often observed due to surface runoff in undulating areas and non-uniform precipitation distribution over the growing season.

## Results and discussion

In the Province of Warmia and Mazury arable land accounts for only 48.5% of the total area. In the entire territory of Poland this index is 54.0%. Grasslands constitute 30.9% of farmland (meadows – 15.4%, pastures – 15.5%), compared with the national average of 21.1%. In 2002 the total area of meadows and pastures in Poland was slightly above 2.53 mln ha and 1.03 mln ha, respectively, while in the Province of Warmia and Mazury - 174 ths ha and almost 175 ths ha. The distribution of meadows and pastures in this region varies widely: grasslands account for 55.4% of arable land in the District of Szczytno, and for only 10.3% in the District of Nowe Miasto Lubawskie.

Table 1. Species occurring most frequently in meadow communities

Group of plants	Mineral soils	Organic soils
Grasses	<i>Poa pratensis</i> , <i>Dactylis glomerata</i> , <i>Phleum pratense</i> , <i>Festuca pratensis</i> , <i>Festuca rubra</i> , <i>Alopecurus pratensis</i> , <i>Anthoxanthum odoratum</i>	<i>Deschampsia caespitosa</i> , <i>Holcus lanatus</i> , <i>Poa pratensis</i> , <i>Alopecurus pratensis</i> , <i>Festuca rubra</i> , <i>Festuca pratensis</i>
Legumes	<i>Vicia cracca</i> , <i>Trifolium repens</i> , <i>Trifolium pratense</i> , <i>Lotus corniculatus</i>	<i>Lotus uliginosus</i> , <i>Lathyrus pratensis</i> , <i>Vicia cracca</i>
Herbs and weeds	<i>Achillea millefolium</i> , <i>Taraxacum officinale</i> , <i>Plantago lanceolata</i> , <i>Heracleum sibiricum</i> , <i>Rumex acetosa</i> , <i>Achillea vulgaris</i> , <i>Stellaria graminea</i> , <i>Ranunculus repens</i>	<i>Cirsium oleraceum</i> , <i>Achillea millefolium</i> , <i>Rumex acetosa</i> , <i>Ranunculus repens</i> , <i>Geum rivale</i> , <i>Ranunculus acris</i> , <i>Filipendula ulmaria</i> , <i>Stellaria graminea</i> , <i>Lychnis flos-cuculi</i> , <i>Potentilla anserina</i>

Meadow and pasture communities are composed of over 30 grass species, between ten and twenty legume species and about 100 species of herbs and weeds. Permanent meadows are usually dominated by high-quality forage grasses, like *Festuca pratensis*, *Phleum pratense*, *Phalaris arundinacea*, *Alopecurus pratensis*, *Poa pratensis* and *Festuca rubra*. Low-quality grasses, such as *Deschampsia caespitosa*, *Holcus lanatus*, *Anthoxanthum odoratum* and *Avenula pubescens*, have a higher proportion in derelict meadows. The abundance of herbs and weeds varies markedly, from 10% - 20% in meadows where the farming level is minimal to even 50% in derelict meadows. Permanent pastures are dominated by high-quality forage grasses, including *Poa pratensis*, *Festuca rubra*, *Festuca pratensis*, *Phleum pratense* and, to a lesser degree, *Lolium perenne*. Legumes are more common in pasture communities than in meadows. *Trifolium repens*, *Lotus corniculatus*, *Medicago lupulina* and *Vicia cracca* occur most frequently. A desirable phenomenon is the presence of such valuable herbaceous plants as *Taraxacum officinale*, *Achillea millefolium*, *Plantago lanceolata* and *Alchemilla vulgaris*. The species composition of plant communities is highly dependent on soil type (Table 1).

According to the cattle and sheep stock registers, in 2002 there were 391.9 ths head of cattle and 9.7 ths head of sheep in the Province of Warmia and Mazury, which accounted for 7.1% and 2.8% of the national populations, respectively. Cattle population density was slightly higher and sheep population density was much lower in the Province of Warmia and Mazury, as compared with the national average. There was a highly significant correlation between

cattle density and the percentage of meadows and pastures in the total farmland area in particular districts. Sheep density was found to be significantly correlated with the proportion of pastures (Table 2).

Table 2. Coefficients of correlation between density and the proportion of meadows and pastures in the farmland in particular districts

Density in the farmland	Population density per 100 ha of arable land		
	Cattle	Cows	Sheep
Meadows	0.814**	0.899**	NS
Pastures	0.700**	0.695**	0.466*

\*\* : P<0.01, \* : P<0.05 and NS: non significant.

Grassland yield is highly variable and dependent on climate and soil conditions, on the botanical composition of sward and on grassland management levels. A lower yield is generally attained in pastures located in dry areas, where water deficiency is one of the major yield-limiting factors. The productivity of permanent grasslands is low, in comparison with their potential, which is assessed to be several-fold higher. In 2002 the mean yield of meadow hay was 4.33 t/ha. The analysis of statistical data shows that the productivity of permanent pastures is lower, on average by about 25% (Grzegorzczak, 1998). This is caused primarily by unregulated water relations, irrational farming practices, insufficient fertilization as well as by considerable loss of the nutritional value during fodder preservation. The results of numerous experiments conducted by the Department of Grassland Management indicate that rational meadow farming enables to attain a yield exceeding 10 t of dry matter and 1.5 t of total protein per ha.

## Conclusions

Grassland occupies a larger area in the Province of Warmia and Mazury, compared to the entire territory of Poland, so cattle density is also higher in this region. Meadow communities show high biodiversity. The productivity of permanent grassland is low, primarily due to unregulated water relations, irrational farming practices and insufficient fertilization.

## References

- Grzegorzczak S. (1998) Productivity of permanent and temporary grasslands in north-eastern Poland. *Scientific Papers of the Agricultural University of Cracow*, 330, 69-74.
- Mannetje L. and Paoletti R. (1992) Grassland production and environment. *Proc. Of the 14<sup>th</sup> General Meeting of The European Grassland Federation*, Lahti, 19-32.
- Wright I.A. (2005) Future prospects for meat and milk from grass-based systems, pp. 161-179, in S.G. Reynolds and J. Frame (eds). *Grasslands: developments, opportunities, perspectives*. Science Publishers, Enfield (USA), Plymouth (UK).

# Effect of defoliation treatment on the reproductive initiation of perennial ryegrass daughter tillers

Hurley G.<sup>1,2</sup>, O'Donovan M.<sup>1</sup> and Gilliland T. J.<sup>2,3</sup>

<sup>1</sup>*Dairy Production Research Centre, Moorepark, Fermoy, Co. Cork, Ireland*

<sup>2</sup>*Faculty of Science and Agriculture, QUB, Newforge Lane, Belfast, Co. Antrim, Northern Ireland*

<sup>3</sup>*Agri-Food and Biosciences Institute, Crossnacreevy, Northern Ireland*

## Abstract

The objective of this experiment was to determine the effect of defoliation treatment and cultivar on the propensity of daughter and subsequent tillers to turn reproductive as the season progressed. Four perennial ryegrass cultivars (*Lolium perenne* L.) were used; AberDart (heading date, 28 May), Fennema (28 May), Melle (16 June) and Twystar (19 June). The experiment commenced after all plants had initiated (EI) and continued until reproductive growth had finished in all plants (FD). Plants from treatment 1 (T1) were defoliated to 30 mm one week after the first tiller initiated. Plants were defoliated to 60 mm once three tillers had reproductively elongated (T2) or headed out (T3). Plants from T1 had significantly less defoliations and ceased reproductive growth 56 days earlier than both T2 and T3. The number of days between EI and FD was less for T1 than both T2 (+ 54 days) and T3 (+55 days). The number of defoliations decreased with later heading cultivars; however Fennema was defoliated more frequently irrespective of treatment. There was no significant effect of cultivar on FD in each treatment. These simulated grazing treatments showed that defoliation at an earlier growth stage reduces the period for the production of reproductive material. It appears that cultivar selection and grazing to a low post grazing height have a positive impact on mid-season sward quality.

Keywords: Perennial ryegrass, cultivar, initiation, reproductive growth, defoliation

## Introduction

During spring, swards change from vegetative to reproductive growth resulting in sward quality deterioration which impacts negatively on milk production and composition. In the Irish dairy production system increased emphasis is being placed on ensuring that the price paid for milk reflects the market returns that can be obtained from that milk in terms of processed products. It is therefore essential that milk composition, in particular protein content is maximised. The proportion of stem in the sward increases mid-season with the onset of inflorescence and has a negative impact on sward quality. Laredo and Minson (1975) established that the leaves of *Lolium perenne* L. had a 20% higher VDMI (Voluntary dry matter intake) than stem fractions even though DM digestibilities were only slightly higher. Careful sward management in spring conditions the sward for mid-season growth, resulting in a leafier sward with less reproductive tillers. Previous studies have shown that by grazing pastures with a high grazing pressure in spring (Holmes and Hoogendoorn 1983) or by pasture topping in spring and early summer (Stakelum *et al.* Unpubl. res.) the proportion of stem and dead material in summer is reduced which leads to increased mid-season sward digestibility and green leaf content. The objective of this experiment was to study the effect of high and low simulated grazing intensities at different growth stages of four perennial ryegrass cultivars on the propensity of daughter and subsequent tillers to turn reproductive as the season progressed.



## Materials and methods

Forty spaced plants of four test cultivars were transplanted at 0.75m intervals to an outdoor site at Moorepark research centre (latitude 50°07'N) in 2005. Plants were vernalised over winter and examinations began in spring 2006. Four diploid perennial ryegrass cultivars were used with the following heading dates; Aberdart (28 May), Fennema (28 May), Melle (16 June) and Twystar (19 June). Previous reproductive initiation data collected by Camlin (1977), were used to generate an 'ear initiation' (EI) versus 'ear emergence' (EE) regression coefficient. This was used as a guide to calculate an expected EI date for each cultivar in the present study, using their published ear emergence dates. Based on this predictive guide, sampling for EI began in mid March prior to the expected EI date of the earliest cultivar. Tillers were removed on alternative days and examined under the microscope for reproductive budding as described by Sweet *et al.* (1991). The presence of a double ridge on the apex indicated that the plant had initiated or turned reproductive. The mean EI date for each cultivar was determined. Four plants of each cultivar were then randomly selected for each of the three defoliation treatments. Plants assigned to treatment one (T1) were defoliated to 30 mm one week after the first tiller initiated, simulating a high grazing intensity. Examination of secondary or subsequent tiller EI began two weeks after defoliation and, as with the first cycle, the plants were defoliated one week after the first tiller initiated. This process continued until reproductive growth ceased. Plants assigned to treatment two (T2) were defoliated to 60 mm once the stem of three tillers on each plant had elongated, i.e. two or more reproductive nodes were present. Plants assigned to treatment three (T3) were defoliated to 60 mm once three seed heads had visibly emerged on each plant. Both T2 and T3 simulated a low grazing intensity management.

## Results and discussion

Ear initiation date was not significantly different between treatments however there was a significant difference ( $P < 0.001$ ) between cultivars (Table 1). *Lolium perenne* L. cultivars have different requirements for vegetative and reproductive growth and development such as critical day length which is the primary factor controlling reproductive initiation of the growth apex. Ear initiation date became later with increased cultivar maturity.

Treatment had a significant ( $P < 0.001$ ) effect on the number of defoliations per plant. There were less plant defoliations under T1 as the lower cutting height (30 mm) would have decapitated more reproductive apices at defoliation. Plants were defoliated most frequently under T2 as they were defoliated at a more advanced growth stage and cutting height was greater (60 mm). At the time of defoliation, tillers were at different stages of growth as the reproductive growth apices of some tillers would have been under the cutting height. Tillers with the reproductive growth apex still attached, would have continued to elongate or head out resulting in another successive defoliation. Cultivar significantly affected ( $P < 0.001$ ) the number of defoliations per plant. In each treatment, the late heading cultivars, Melle and Twystar had the lowest number of defoliations, while Aberdart and Fennema both had a greater number of defoliations per treatment. Results indicate however that a large genetic variation exists between cultivars for re-heading, whereby Fennema continued reproductive growth regardless of treatment while the later heading cultivars returned to a vegetative growth mode earlier.

There was a significant effect of treatment on the number of days between defoliations ( $P < 0.01$ ), the final defoliation date ( $P < 0.001$ ) and the period between EI and final defoliation (A – B;  $P < 0.001$ ). T1 had a lower defoliation or simulated grazing height (30 mm), therefore reproductive apices were decapitated more frequently (21 days) and more severely within in a

shorter period (64 days). Plants from T2 and T3, which had a higher defoliation or simulated grazing height (60 mm), had longer regrowth intervals between defoliations (23 and 30 days respectively) during an extended reproductive growth period (118 and 119 days respectively). The final date of defoliation after reproductive growth ceased was 10 June for T1, while plants from T2 and T3 continued to produce reproductive material longer into the mid-season period (+56 days and +57 days respectively). Cultivar also had a significant ( $P < 0.01$ ) effect on defoliation intervals. In all treatments Fennema had the shortest period between defoliations due to its high propensity to return to a reproductive growth mode after each defoliation. There was however no significant effect of cultivar on the final defoliation date thus all cultivars returned to a vegetative growth mode at a similar time. The reproductive period between EI and final defoliation (A – B) was significantly ( $P < 0.001$ ) longer for early heading cultivars (Aberdart and Fennema) than later heading cultivars in all treatments due to a significantly earlier EI date.

Table 1. Ear initiation (EI) date, number of plant defoliations, date of final cut and the time between EI and final defoliation of four cultivars across three treatments

	Mean EI date (A)			Mean number of defoliations			Mean defoliation intervals (days)			Mean final defoliation (B)			Reproductive period days (A – B)		
	T1	T2	T3	T1	T2	T3	T1	T2	T3	T1	T2	T3	T1	T2	T3
AD	22/3	31/3	29/3	3.8	5.0	4.3	21	24	33	8/6	27/7	16/8	78	118	140
FN	22/3	27/3	24/3	4.3	7.3	5.0	19	20	27	12/6	17/8	8/8	82	143	137
ML	26/4	20/4	24/4	2.0	4.8	3.5	22	22	28	8/6	4/8	30/7	43	106	97
TR	23/4	21/4	23/4	2.5	4.3	3.3	21	26	32	15/6	5/8	2/8	53	106	101
<i>Mean</i>	<i>7/4</i>	<i>9/4</i>	<i>9/4</i>	<i>3.1</i>	<i>5.4</i>	<i>4.0</i>	<i>21</i>	<i>23</i>	<i>30</i>	<i>10/6</i>	<i>5/8</i>	<i>6/8</i>	<i>64</i>	<i>118</i>	<i>119</i>
T	NS			***			**			***			***		
C	***			***			*			NS			***		
T*C	*			NS			NS			NS			NS		
SED	1.40			0.33			1.37			7.06			7.33		

EI = Ear initiation; T1 = Treatment 1; T2 = Treatment 2; T3 = Treatment 3; AD = Aberdart; FN = Fennema; ML = Melle; TR = Twystar; C = Cultivar; T = Treatment, SED = Standard Error of Difference; \*\*\* =  $P < 0.001$ ; \* =  $P < 0.05$ ; NS = Non Significant

## Conclusion

Defoliation treatment and cultivar choice had a large impact on reproductive growth of mid-season perennial ryegrass tillers. Defoliating to a low height (30 mm), or simulating a high grazing intensity, during the early tiller growth stage resulted in plants returning to vegetative growth earlier than plants defoliated under a high defoliation height (60 mm). Late heading cultivars tended to have a shorter reproductive period than earlier heading cultivars. There are however large genetic differences between cultivars, as Fennema was defoliated most frequently and had the longest reproductive period regardless of treatment. A defoliation interval of 21 days is a common grazing practice mid-season in Irish dairy production systems. The results of this study suggest that defoliating swards under a high grazing intensity with a short grazing interval (21 days) while selecting cultivars with low re-heading vigour results in less reproductive material produced during a shorter period mid-season.

## References

- Camlin M. S. (1977) Growth and management of early, mid-season and late varieties of perennial ryegrass. In: *Advisers and lecturers conference*, Loughry college.
- Holmes C. W. and Hoogendoorn C. J. (1983) Some effects of grazing management in early lactation and topping on the growth and quality of pasture. In: *Dairyfarming Annual, Massey University, Palmerston North, N.Z.*, 36-43.
- Laredo M. A. and Minson D. J. (1975) The voluntary intake and digestibility by sheep of leaf and stem fractions of *Lolium perenne*. *Journal of British Grassland Society* 30, 73-77.
- Stakelum G., Dillon P. and Delaby L. (Unpubl. res.) The effect of pasture topping and grazing pressure in spring/early summer in rotationally grazed pastures on subsequent sward characteristics and dairy cow performance.
- Sweet N., Wiltshire J. J. J. and Baker C. K. (1991) A new descriptive scale for early reproductive development in *Lolium perenne* L. *Grass and Forage Science* 46, 201-206.

# Changes in chemical composition, digestibility and energy content in permanent grassland influenced by intensity of utilization and fertilization

Pozdíšek J.<sup>1</sup>, Štýbnarová M.<sup>1</sup>, Svozilová M.<sup>2</sup> and Látal O.<sup>2</sup>

<sup>1</sup> Research Institute for Cattle Breeding, Ltd., 78813 Vikýřovice, Czech Republic

<sup>2</sup> Agrosearch, Ltd., Výzkumníkù 267, 78813 Vikýřovice, Czech Republic

## Abstract

The aim of this study was to evaluate the effects of cutting intensity and fertilization of permanent grassland on chemical composition, organic matter digestibility and energy content (ME, NEL and NEF). The long-term small plot trial was established in 2003 in Rapotín. The trial was managed during 2003 and 2005 with four levels of cutting intensity and four levels of fertilization: no fertilization, P<sub>30</sub>K<sub>60</sub>, N<sub>90</sub>P<sub>30</sub>K<sub>60</sub>, N<sub>180</sub>P<sub>30</sub>K<sub>60</sub>. The nutritive value was estimated on the basis of the Weende analysis and *in vitro* organic matter digestibility. Average values for energy concentration (NEL) in the intensive utilization were 5.68 g kg<sup>-1</sup> DM in year 2003 and 5.49 g kg<sup>-1</sup> DM in year 2005. Decreasing intensity of utilization significantly reduced the content of energy in the forage up to 5.24 g kg<sup>-1</sup> DM in year 2005. With frequent cutting and with fertilizer application it is possible to influence forage quality.

Keywords: production, nutritive value, mineral fertilization, utilization

## Introduction

In relation to the stagnation in the consumption of agricultural products an expansion of the area of permanent grassland in the Czech Republic can be expected. In this situation it is necessary to identify the most suitable methods of grassland management for the future. Permanent grassland management for cattle breeding appears particularly attractive. For the practical planning and application of such a system it is important to use knowledge on feed intake from other countries.

For example, Gruber *et al.* (2000) found that the voluntary intake of forage from grassland was 10.4, 13.0, 15.2 kg DM per head for three different methods of utilization. It is important to provide the necessary quality of the feedstuffs to satisfy the animals' requirements. Pozdíšek *et al.* (2002) point out that quality depends on the species and varieties and on the type of management. With the suitable frequency of utilization of grassland an energy concentration (NEL) of 6.1 MJ.kg<sup>-1</sup> DM can be achieved, but with less frequent utilization this value may decrease to 4.9 MJ.kg<sup>-1</sup> DM.

## Materials and methods

A long-term small plot trial was established in 2003 on permanent grassland sites in the locality Rapotín. It consists of 16 treatments, in 4 replicates, with a 10 m<sup>2</sup> harvest plot size. The grassland vegetation on the experimental stands was classified as *Arrhenatherion*. The dominant species in the permanent sward were *Dactylis glomerata*, *Poa pratensis*, *Lolium perenne*, *Trifolium repens* and *Taraxacum sect. Ruderalia*

It was managed with four levels of the intensity of utilization:

I<sub>1</sub> = intensive (1<sup>st</sup> cut by May 15<sup>th</sup>, 4 cuts per year – cuts at 45-day interval),

I<sub>2</sub> = medium intensive (1<sup>st</sup> cut between 16<sup>th</sup> and 31<sup>st</sup> May, 3 cuts per year at 60-day interval),

I<sub>3</sub> = low intensive (1<sup>st</sup> cut between 1<sup>st</sup> and 15<sup>th</sup> June, 2 cuts per year at 90-day interval) and

I<sub>4</sub> = extensive (1<sup>st</sup> cut between 16<sup>th</sup> and 30<sup>th</sup> June, 1 or 2 cuts per year, second cut after 90 days).

Each utilization treatment was divided to give four levels of fertilization:

F<sub>0</sub> = no fertilization, F<sub>PK</sub>=P<sub>30</sub>K<sub>60</sub>N<sub>0</sub>; F<sub>PKN90</sub>=P<sub>30</sub>K<sub>60</sub>+N<sub>90</sub>, F<sub>PKN180</sub>=P<sub>30</sub>K<sub>60</sub>+N<sub>180</sub> (pure nutrients).

The annual dry matter production was measured for all plots. The samples from these plots (all treatments and replicates, 352 in total) collected during 2003 and 2005 were analyzed in laboratories of the Research Institute for Cattle Breeding, Ltd., Rapotin. The values for nitrogen compounds, fat, crude fibre and ash were estimated by the Weende analysis. The FIBERTEC 2023 FIBERCAP FOSS TECATOR was used to analyse structural fibre. The estimation of the organic matter digestibility was carried out by means of the *in vitro* method Tilley and Terry (1968) modified according Resch (1991). Forage quality in terms of ME (metabolisable energy), NEL (net energy of lactation), NEF (net energy of fattening), was predicted by the equations of Petrikovič *et al.*, 2000.

The results were statistically evaluated with two-factor analysis of variance with one observation in the subclass; the differences between the averages were tested by the Tukey test (DT<sub>0.05</sub>, DT<sub>0.01</sub>).

## Results and discussion

Data according to the intensity of utilization (part A) and according to the fertilization (part B) are given for 2003 in Table 1 and for 2005 in Table 2.

Table 1. Forage quality of grasslands at different levels of intensity of utilization and fertilization in 2003

Treatments intensity of utilization and fertilization	DM (t ha <sup>-1</sup> )	CP (g kg <sup>-1</sup> DM)	CF (g kg <sup>-1</sup> DM)	NDF (g kg <sup>-1</sup> DM)	ADF (g kg <sup>-1</sup> DM)	OM (g kg <sup>-1</sup> DM)	OMD (%)	ME (MJ kg <sup>-1</sup> DM)	NEL (MJ kg <sup>-1</sup> DM)	NEF (MJ kg <sup>-1</sup> DM)
A										
I 1	7.10	176.9	224.8	501.5	299.2	897.0	70.7	9.62	5.68	5.53
I 2	8.37	159.0	241.2	519.8	314.8	900.1	69.4	9.48	5.58	5.42
I 3	7.75	121.4	290.2	596.0	360.7	913.1	66.2	9.18	5.37	5.16
I 4	6.99	115.0	302.3	611.0	372.2	922.3	66.0	9.23	5.40	5.19
AVG	7.55	143.1	264.6	557.0	336.7	908.1	68.1	9.37	5.51	5.32
DT0,05	0.58	5.1	11.3	27.1	9.5	5.6	0.7	0.11	0.08	0.10
DT0,01	0.71	6.3	13.7	33.0	11.6	6.8	0.9	0.14	0.09	0.12
B										
F0	6.57	133.2	261.6	545.5	335.5	909.1	68.3	9.42	5.54	5.37
FPK	6.85	135.9	265.0	551.2	337.5	906.4	67.8	9.32	5.48	5.29
FPKN90	8.43	146.2	265.1	567.0	337.0	907.3	68.0	9.36	5.49	5.31
FPKN180	8.35	156.9	266.7	564.5	336.9	909.6	68.2	9.40	5.52	5.33
AVG	7.55	143.1	264.6	557.0	336.7	908.1	68.1	9.37	5.51	5.32
DT0,05	0.58	5.1	11.3	27.1	9.5	5.6	0.7	0.11	0.08	0.10
DT0,01	0.71	6.3	13.7	33.0	11.6	6.8	0.9	0.14	0.09	0.12

The ordering of these tables makes it possible to compare the influence of the different intensity of utilization and fertilization.

The overall average dry matter production for the sixteen treatment combinations was 7.55 t.ha<sup>-1</sup> in 2003 and 7.04 t.ha<sup>-1</sup> in 2005. The dry matter production was lowest with intensive utilization (7.10t.ha<sup>-1</sup> and 6.30t.ha<sup>-1</sup>) (see Table 1A and 2A), confirming the results of Gruber *et al.* (2000). They state, on the basis of the evaluation of the long-term trials at BAL

Gumpenstein, that increased cutting frequency decreased yield especially when four cuts were taken (8.65, 8.05, 6.51 t.ha<sup>-1</sup> DM, with 2, 3 and 4 cuts respectively).

Average values for contents of crude protein in the intensive utilization (see Table 1A and 2A) were 176.9 g kg<sup>-1</sup> DM in year 2003 and 147.6 g kg<sup>-1</sup> DM in year 2005. With extensive utilization average values were 115.0 g kg<sup>-1</sup> DM in 2003 and 94.4 g kg<sup>-1</sup> DM in 2005. The content of crude protein fell with reduced intensity of utilization and cutting frequency, in line with the results of Gaisler and Fiala (2003).

Table 2. Forage quality of grasslands at different levels of intensity of utilization and fertilization in 2005

Treatments intensity of utilization and fertilization	DM (t ha <sup>-1</sup> )	CP (g kg <sup>-1</sup> DM)	CF (g kg <sup>-1</sup> DM)	NDF (g kg <sup>-1</sup> DM)	ADF (g kg <sup>-1</sup> DM)	OM (g kg <sup>-1</sup> DM)	OMD (%)	ME (MJ kg <sup>-1</sup> DM)	NEL (MJ kg <sup>-1</sup> DM)	NEF (MJ kg <sup>-1</sup> DM)
<b>A</b>										
I 1	6.30	147.6	248.8	548.9	322.3	891.8	69.0	9.33	5.49	5.32
I 2	5.79	129.9	276.9	567.0	346.4	895.0	66.8	9.07	5.30	5.08
I 3	7.94	101.6	302.4	613.9	373.1	912.6	66.0	9.13	5.35	5.14
I 4	8.12	94.4	312.9	639.3	382.8	911.2	65.0	8.98	5.24	5.01
AVG	7.04	118.4	285.2	592.3	356.1	902.7	66.7	9.13	5.34	5.14
DT0,05	0.35	6.4	11.9	22.3	9.6	5.1	0.9	0.14	0.10	0.12
DT0,01	0.43	7.8	14.6	27.2	11.7	6.3	1.2	0.18	0.12	0.15
<b>B</b>										
F0	5.33	107.1	280.2	583.0	353.6	902.8	67.0	9.17	5.38	5.19
FPK	5.93	107.7	282.4	558.9	353.0	894.6	66.0	8.96	5.24	5.02
FPKN90	8.46	120.1	288.6	602.2	359.2	906.4	66.8	9.18	5.38	5.17
FPKN180	8.42	138.6	289.8	624.9	358.7	906.8	66.9	9.20	5.38	5.17
AVG	7.04	118.4	285.2	592.3	356.1	902.7	66.7	9.13	5.34	5.14
DT0,05	0.35	6.4	11.9	22.3	9.6	5.1	0.9	0.14	0.10	0.12
DT0,01	0.43	7.8	14.6	27.2	11.7	6.3	1.2	0.18	0.12	0.15

The amount of CF, NDF and ADF in DM also influences the quality of the grassland and its effects on animal nutrition. The average content of CF varied from 224.8g kg<sup>-1</sup>DM to 312.9g kg<sup>-1</sup>DM according to the intensity of utilization during the monitored years, with some differences being significant. This corresponds with the results published previously by Pozdíšek *et al.* (2003) and other authors. On the contrary, the differences in CF were not significant comparing the levels of fertilization; it ranged from 261.6g kg<sup>-1</sup>DM to 289.8g kg<sup>-1</sup>DM, on average. There were similar patterns if results for the contents of NDF and ADF.

The mean results for organic matter digestibility ranged from 71.0 % to 65.0 %. Intensity of utilization had large and significant effects on organic matter digestibility, with decreasing intensity of utilization reducing OMD.

Intensity of utilization also significantly influenced the content of energy (ME, NEL and NEF) in the forage confirming the findings of Gruber *et al.* (2000). Average values for energy concentration (NEL) in the intensive utilization were 5.68 g kg<sup>-1</sup> DM in year 2003 and 5.49 g kg<sup>-1</sup> DM in year 2005. Decreasing intensity of utilization significantly reduced the content of energy in the forage up to 5.24 g kg<sup>-1</sup> DM in year 2005. These changes in the nutritive value are connected with the maturing of the stand and with the continuing lignifications of the plants. The influence of the fertilization treatments was not significant.

## Conclusion

The amount and the quality of the fodder can be significantly influenced by means of the grassland management, i.e. via type of utilization and fertilization. In particular, extensive grassland utilization with few cuts taken per year results in deterioration of the nutritive value of the forage. These findings are important for the nutrition of cattle and for efficient grassland management.

## Acknowledgements

The work was partly supported by the research of the National Agency Agricultural Research project with No. QF 3018 and by Ministry of Education CR, Prague No. MSM 2678846201.

## Reference

- Gaisler J. and Fiala J. (2003) Vliv hnojení a počtu sečí na botanické složení, výnos a kvalitu píče trvalého travního porostu. In: Ekologicky šetrné a ekonomicky přijatelné obhospodařování travních porostů. Prague, 99-105.
- Gruber L., Steinwidder A., Guggenberger T., Schauer A., Häusler J., Steinweder R. and Steiner B. (2000) Einfluss der Grünlandbewirtschaftung auf Ertrag, Futterwert, Milcherzeugung und Nährstoffausscheidung. In: *Bericht 27. Viewirtschaftliche Fachtagung, BAL Gumpenstein 6.-8. 6. 2000*, 41-88. ISBN 3-901980-43-1.
- Petrikovič P., Sommer A., Čerešňáková Z., Svetlanská M., Chrenková M., Chrastinová L., Poláčiková M., Bencová E., Dolešová P. (2000) The feed nutritive value, part I. ( in Slovak). VÚZV, Nitra, 2000, ISBN 80-88872-12-X.
- Pozdíšek J., Míka V., Kohoutek A., Jakešová H., Němcová-Schuplerová P. (2002) Nutritive value of selected grass species (cultivars) and tetraploid red clover. In: *Multi-functions grasslands, Quality Forages, Animal Products and Landscapes*. Proceedings of the 19<sup>th</sup> General Meeting of the European Grassland Federation La Rochelle, France, 150.
- Pozdíšek J., Kohoutek A., Jakešová H. and Divišová P. (2003) Kvalita píče jako významný faktor exploatace travních porostů. In: Ekologicky šetrné a ekonomicky přijatelné obhospodařování travních porostů. Prague, 224-237.
- Resch R. (2004) Die Bestimmung der *in vitro* - Verdaulichkeit mit der modifizierten Zweistufenmethode nach Tilley and Terry (1968) an der Bundesanstalt für Alpenländische Landwirtschaft Gumpenstein. Vervielfältigtes Manuskript für das Vorlesungsseminar Grünlandwirtschaft II, Irdning / BAL Gumpenstein 19.5.2004.

# The effects of an extended grassland utilisation in autumn on the following spring yield

Lobsiger M.<sup>1</sup>, Mosimann E.<sup>2</sup>, Jeangros B.<sup>2</sup> and Lüscher A.<sup>3</sup>

<sup>1</sup> Swiss Grassland Society, Reckenholzstr. 191, CH-8046 Zurich, Switzerland

<sup>2</sup> Agroscope Changins-Wädenswil Research Station ACW, CH-1260 Nyon 1, Switzerland

<sup>3</sup> Agroscope Reckenholz-Tänikon Research Station ART, Reckenholzstr. 191, CH-8046 Zurich, Switzerland

## Abstract

To reduce forage costs, the grazing season in autumn is often extended until the end of November. The consequences of a later closing date in autumn on pasture production during the following spring pasture are largely unknown under mid-European climatic conditions. An experiment was carried out over a three-year period at two sites in the Swiss lowlands comparing the effect of three different closing dates in autumn (early October, late October and late November). The aim was to determine how much herbage mass must be left standing before winter to guarantee a vigorous growth the following spring. Delaying the closing date from early October to late November allowed 781 kg DM ha<sup>-1</sup> additional yield to be harvested, but significantly reduced the spring yield by 53% (470 kg DM ha<sup>-1</sup>) in early April and 19% (783 kg DM ha<sup>-1</sup>) in May. The variation between sites and year were considerable (e.g. 159-1181 kg DM ha<sup>-1</sup> for the additional yield harvested in autumn). The reduction in spring yield was particularly high (up to 75%) when the residual yield before winter (end November) was below 300-500 kg DM ha<sup>-1</sup>. On the other hand, residual yield before winter above this threshold did not increase spring yield significantly. Thus, pasture utilisation in late autumn can be recommended if conditions are favourable and if grazing does not reduce the residual yield, before winter, to under 300-500 kg DM ha<sup>-1</sup>, which corresponds to a herbage height of 5-6 cm (plate pasture meter).

Keywords: grassland, cattle, pasture, dry matter yield, closing date

## Introduction

Grazed grass is the most economic forage for dairy cows. Furthermore, grazing greatly contributes to a positive image of sustainable agriculture and to the well-being of dairy cows. For this reason, most dairy farmers try to extend the autumn grazing period. The consequences of this extension are largely unknown under mid-European climatic conditions. In Ireland, Roche *et al.* (1996) and O'Donnovan *et al.* (2002) showed that delaying the closing date reduced the grass yield during the following spring. The objective of this experiment was to determine the effects of the closing date in autumn and of the utilisation type (cutting and grazing) on the grass yield the following spring in the Swiss lowlands. The weakening of the plants caused by extended grazing in late autumn was expected to lead to greater losses in spring than observed in Ireland because of the lower winter temperatures and the longer periods of snow cover in Switzerland. In the same way, it is known, from a European multi-site experiment, that the amount of residual leaf area in late autumn for white clover is positively related to its regrowth the following spring (Wachendorf *et al.*, 2001, Lüscher *et al.*, 2001). Particularly interesting was the question of how much herbage mass must be left standing before winter to guarantee a vigorous growth the following season.



## Materials and methods

The experiment was carried out from autumn 2001 to spring 2004 in the Swiss lowlands, on two dairy pastures with continuous stocking. The two sites were Langenthal (Canton of Berne) with very favourable conditions for grassland production (1157 mm rainfall per year, mean temperature Dec.-Feb.: 0.9°C) and Saint-Livres (Canton of Vaud) with a dry period in summer (1079 mm rainfall per year, mean temperature Dec.-Feb.: 2.5°C). These pastures were sown with grass/clover-mixtures as for most sown grassland in Switzerland. The experiment included 6 treatments: two types of utilisation (cut or grazed), each with three dates for the last utilisation (early October, late October or late November), and each one was replicated 5 times. Grass yield in the following spring was measured on three different dates (March, April and May).

## Results and discussion

Table 1 shows the mean yields in spring, averaged over both sites. The influence of the closing date on the yield in March, April and May was highly significant while the type of utilisation in autumn did not influence the DM yield in spring. Delaying the last utilisation from early October to late November reduced the yield in March of the following year by 69% or 330 kg DM ha<sup>-1</sup>, in early April by 53% or 470 kg DM ha<sup>-1</sup> and in May by 19% or 783 kg DM ha<sup>-1</sup>, in average over both sites. Thus, in absolute measures, the biggest loss between the treatments "early" and "late closing date" occurred in May with an average loss of 783 kg DM ha<sup>-1</sup>. These results are in accordance with studies in Ireland where Roche *et al.* (1996) found a loss of 590 kg DM ha<sup>-1</sup> in March if the closing date in autumn was delayed from October 20<sup>th</sup> to December 2<sup>nd</sup>.

Table 1 Effect of autumn closing date and type of utilisation on herbage dry matter yield in spring (kg DM ha<sup>-1</sup>, averaged over the two sites St. Livres and Waldhof, se: standard error)

Closing Date (CD)	early Oct.		late Oct.		late Nov.		se	Significance (P)		
	cut	grazed	cut	grazed	cut	grazed		U	CD	UxCD
Mid March 2002	608	754	232	371	148	100	59	ns	< 0.001	ns
Mid March 2003	280	281	153	212	99	59	37	ns	< 0.001	ns
Mid March 2004	234	598	144	186	130	237	49	< 0.001	< 0.001	0.005
<i>Mean Mid March</i>	459		216		129					
Early April 2002	1355	1435	782	893	618	529	75	ns	< 0.001	ns
Early April 2003	1087	1087	802	941	835	639	70	ns	< 0.001	ns
Early April 2004	326	362	213	252	123	89	46	ns	< 0.001	ns
<i>Mean Early April</i>	942		647		472					
Early May 2002	3644	3681	3003	2921	2922	2432	113	ns	< 0.001	ns
Early May 2003	4436	4085	3872	4050	3696	3273	132	ns	< 0.001	ns
Early May 2004	4730	5079	4477	4583	4310	4327	166	ns	0.005	ns
<i>Mean Early May</i>	4276		3818		3493					

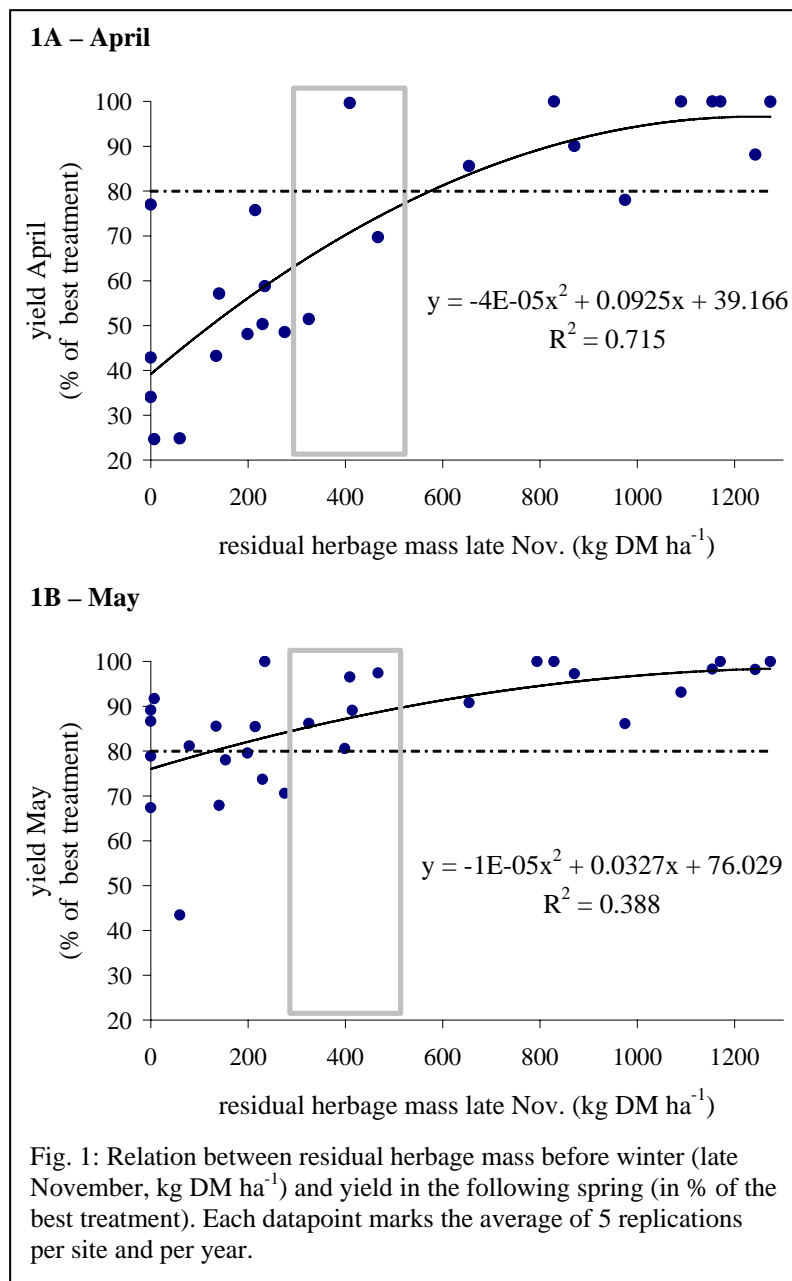

On the other hand, the delay of the last utilisation from early October to late November resulted in an additional yield harvested in autumn of 781 (389-1147) kg DM ha<sup>-1</sup>, averaged over both sites. However, the variations between the two sites and the three years were substantial (an effect also described by Hennessy *et al.* 2006). This became obvious if the results were not averaged over the two sites. In this case, the gain of a late closing date in autumn ranged between 159 and 1181 kg DM ha<sup>-1</sup> and the loss in May varied between 225 and 1512 kg DM ha<sup>-1</sup>. The reason for this variation between sites and years was that the date when the minimum temperature threshold allowing plant growth was reached in late autumn and early spring varied greatly. As a result of this variation, the balance between the gain in autumn and the loss in the following May differed considerably. It was ranged from -708 kg DM ha<sup>-1</sup> and +653 kg DM ha<sup>-1</sup> (results not shown). This

demonstrates clearly that under such annual and spatial variability of climatic conditions it is not possible to recommend a fixed date for the last utilisation applicable over a large region. Thus, the question was: how much herbage mass must be left before winter in order to guarantee a vigorous regrowth of the pasture during the following spring?

The relation between standing biomass in late autumn and yield in the following spring is presented in Figure 1 (spring yield is shown in percentage of the best treatment measured in spring; 1A for April, 1B for May). The data show a clearly reduced spring yield with decreasing standing biomass in autumn. The effect was greater below a pre-winter residual herbage mass ranged between 300-500 kg DM ha<sup>-1</sup>. If residual herbage mass before winter was below this threshold the yield harvested in April was only 25% to 80% of the best treatment, i.e. the loss was up to 75% of the yield from the best treatment. We also found that below this critical threshold of 300-500 kg DM ha<sup>-1</sup> we lose up to 2.6 kg DM in spring for every additional kg DM harvested in autumn (result not shown).

These results are in accordance with observations on white clover, in an European multi-site experiment, where the residual leaf area in autumn was an important determinant of efficient spring regrowth (Wachendorf *et al.*, 2001, Lüscher *et al.*, 2001).

Figure 1 also shows that residual herbage mass before winter of more than 300-500 kg DM ha<sup>-1</sup> did not lead to a significantly higher yield in the spring. It seems that above this threshold, additional leaf area has no further positive effects on the spring growth of the plants. In contrast, the risk for fungal diseases and damage by mice increases if residual biomass before winter is too high.

## Conclusion

1. Under the climatic conditions of the Swiss lowlands, the utilisation of pasture in late autumn is recommended if conditions are favourable and if grazing does not reduce the pre-winter residual yield below 300-500 kg DM ha<sup>-1</sup>, corresponding to a herbage height of 5-6 cm (plate pasture meter, model Jenquip, New Zealand). If pastures are used more intensively and/or later, i.e. below this threshold, the gain of forage in autumn is reduced or even overset by losses in the following spring. Consequently, the start of the grazing season would be delayed.
2. Nevertheless, herbage mass before winter should not exceed 500 kg DM ha<sup>-1</sup> since no gain for grassland production in the following spring can be expected.
3. The planning of autumn grazing must be performed according to a sward height threshold target that could be applied to a broader range of climatic conditions than a planning focussed on a fixed date for the last utilisation.

## References

- Lüscher A., Stäheli B., Braun R. and Nösberger J. (2001) Leaf area, competition with grass, and clover cultivar: Key factors to successful overwintering and fast regrowth of white clover (*Trifolium repens* L.) in spring. *Annals of Botany*, 88, 725-735.
- Hennessy D., O'Donovan M., French P. and Laidlaw A. S. (2006) Effects of date of autumn closing and timing of winter grazing on herbage production in winter and spring. *Grass and Forage Science*, 61:363-374.
- O'Donovan M., Dillon P., Reid P., Rath M. and Stakelum G. (2002) A note on the effects of herbage mass at closing and autumn closing date on spring grass supply on commercial dairy farms. *Irish Journal of Agricultural and Food Research*, 41, 265-269.
- Roche J.R., Dillon P., Crosse S. and Rath M. (1996) The effect of closing date of pasture in autumn and turnout date in spring on sward characteristics, dry matter yield and milk production of spring calving cows. *Irish Journal of Agricultural and Food Research*, 35, 127-140.
- Wachendorf M., Collins R.P., Elgersma A., Fothergill M., Frankow-Lindberg B.E., Ghesquiere A., Guckert A., Guinchard M.P., Helgadottir A., Lüscher A., Nolan T., Nykänen-Kurki P., Nösberger J., Parente G., Puzio S., Rhodes I., Robin C., Ryan A., Stäheli B., Stoffel S., Taube F. and Connolly J. (2001) Overwintering of *Trifolium repens* L. and succeeding spring growth: A model approach to plant-environment interactions. *Annals of Botany*, 88, 683-702.

# Phenological spring development and nutritive value of brome grass

Nagy G.

*Department of Rural Development, Centre of Agriculture Sciences, University of Debrecen, H-4032 Debrecen, Hungary*

## Abstract

Field investigations on the phenological development of Hungarian Brome grass (*Bromus inermis* L.) and laboratory analysis of its chemical composition were made in springtime, between 2004 and 2006. Phenological spring development of brome grass between mid-April and early June is described by the following morphological data: extended shoot height (ESH); total number of leaves per shoot developed, number of dead leaves per shoot, number of active leaves per shoot, sum of active leaf lamina lengths (SALL) per shoot. High number of active leaves on the shoots prove the leafy character of brome grass during primary growth. The chemical composition of brome grass samples taken 5 (2004) and 6 (2005) times during primary growth from pure stands showed differences at a high level of significance. Crude protein, fat and ash content, as well as net energy values, decreased remarkably over time. At the same time, crude fibre and nitrogen-free extract content increased. These data contribute towards making a more objective evaluation of brome grass during primary growth.

Keywords: brome grass, phenological development, chemical composition, primary growth

## Introduction

Harvestable grass yield during the defoliation of primary growth in spring is constituted basically from the stems (vegetative or generative) and leaves (sheath and lamina). In the case of late utilization, these are supplemented with inflorescence. Spring development of these grass parts on a tiller shows a well known pattern (Robson *et al.*, 1988, Nelson and Moser, 1995). After a tiller has been differentiated and starts to grow, the vegetative stems remain short (consisting of nodes and very short internodes) hidden under the leaves' sheaths and new leaves are developing consistently from the nodes within certain periods of time. The leaves which now develop have a limited life span (e.g. 3 weeks) after which they die and are replaced by the new leaves. This procedure is terminated by the generative development, whereas the vegetative shoot elongates, overgrows the last leaf sheath, and finally differentiates into the reproductive structure, the inflorescence. Phenological changes of grass development in spring are associated with fundamental chemical composition changes (Gill *et al.*, 1989, Dwayne and Mertens, 1995) which have major influence on the nutritive value of the herbage harvested. Both phenological and nutritive value changes may differ between years, species and cultivars. This was the reason why a research programme was conducted with five grass species at Debrecen University, Hungary. This paper presents the results of the phenological development and nutritive value of *Bromus inermis* during primary growth in Hungary, based on 3 year (2004-2006) field and 2 year (2004-2005) laboratory investigations.

## Materials and methods

Pure stands of different grass species and cultivars of high agronomic value are grown under field conditions at the demonstration garden of Debrecen University, Agricultural Center with the following ecological conditions. The soil structure is a high fertility loam (chernozem).

The average climatic conditions (last forty years) till middle June are: precipitation: 227 mm, T-sum of mean daily temperatures: 1244 °C, sum of sunny hours per day: 889 hours. Individual shoots of brome grass (n=30 per cultivar) were randomly selected from the pure stand and tagged with a plastic ribbon. Leaves on the shoot were numbered from the ground; the tags were placed between the last dead and the first live leave on the first day of measurement. Phenological measurements were then repeated seven times (altogether 8 measurements) in 4-8 days intervals between mid-April and early June.

Registered primary data on each shoot and each occasion in the order of measurements were:

- extended shoot height (ESH),
- number of dead leaves (a leaf was considered dead if more than half of the leaf lamina from the tip was withered),
- lamina length of the live leaves (cm).

During the evaluation procedure, secondary data were generated from the primary data:

- number of leaves per shoot developed on each date,
- number of dead leaves per shoot on each date,
- number of active leaves per shoot on each date,
- sum of active/live leaf lamina (SALL) lengths on the shoot (cm).

Grass samples for laboratory analysis were cut on 5 (2004) and 6 (2005) occasions during primary growth from the same fields of pure brome grass stands (n=3 per occasions). Samples were treated and investigated according to the Hungarian Standards for forage chemical composition evaluations (MSz 6830). Data of the investigation were statistically analyzed by the SPSS computer programme package.

## Results and discussion

For the evaluation of the existing weather conditions during the investigation periods of time, the climate index (Vinczeffy, 1991) has been calculated (Figure 1).

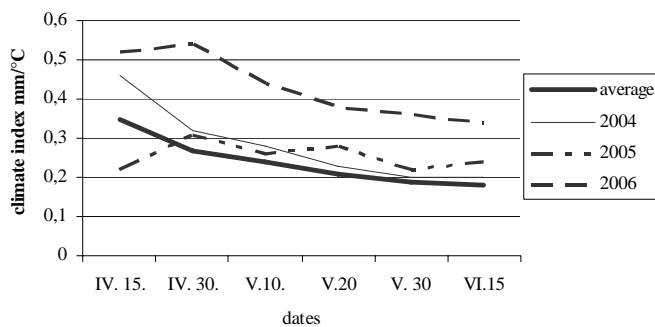

Figure 1: Climate index (Vinczeffy, 1991) in the years of field measurements

Each year had a higher climate index than that of the last forty year average, except for the beginning of the 2005 investigation period. Detailed data of annual precipitation, temperature sum from the 1<sup>st</sup> of January based on the positive mean daily temperature values, and the annual sum of the daily sunny hours show, that these higher climate index values are primarily due to the more rainy weather in the given years. In 2004, the annual rainfall was remarkably higher (+5–51%); in 2005, it was reasonably more (+11–30%) and in 2006, it was outstandingly more (+87–121%) than that in the average year. The annual sum of the sunny hours was around the average (-4–+2%) in 2004, was reasonably higher (+9–+15%) in 2005 and reasonably lower (-8–12%) in 2006.

The extended shoot height (Figure 2) has intensively grown during the investigation periods except for 2006, when the ESH increase was a bit slower. The mean shoot height for the first

and the last day of measurement were 41,67 cm ( $s=9,94$ ) and 128,62 cm ( $s=7,63$ ) in the first year, 32,17 cm ( $s=4,72$ ) and 127,08 cm ( $s=13,36$ ) in the second year and 50,35 cm ( $s=4,86$ ) and 108,68 ( $s=10,75$ ) in the third year of investigations. The reasonably lower final ESH for 2006 may probably be due to the reduced sunny hours (-8–12%), as in the absence of water stress, light (irradiance) is an important environmental variable affecting grass growth (Robson *et al.*, 1988).

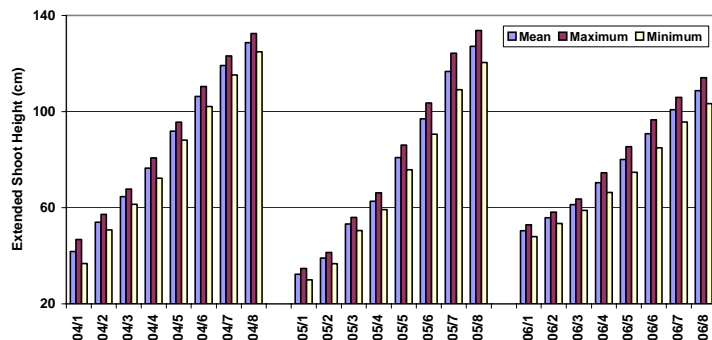

Figure 2. Extended shoot height of brome grass during primary growth

The total number of leaves per shoot developed between the first and last day of measurements (Figure 3) has changed from 7,57 pc ( $s=0,50$ ) to 8,73 pc ( $s=0,52$ ), from 5,50 pc ( $s=0,78$ ) to 9,03 pc ( $s=0,96$ ) and from 7,13 pc ( $s=0,78$ ) to 8,27 pc ( $s=0,89$ ) for 2004, 2005 and 2006 respectively. The relatively high number of leaves per shoot developed by the end of the primary growth supports the leafy character of brome grass compared to some less leafy grasses, e.g. perennial ryegrass (Peeters, 2005). The average number of dead leaves per shoot by the end of the investigations were 2,37 pc ( $s=0,62$ ), 2,93 pc ( $s=0,91$ ) and 2,73 pc ( $s=0,52$ ) for 2004, 2005 and 2006 respectively. Correspondingly the average number of live leaves per shoot for the same dates were 6,37 pc ( $s=0,68$ ), 6,10 pc ( $s=0,71$ ) and 5,53 pc ( $s=0,97$ ) for the successive years respectively. These results also support the leafy character of this species. Average size of the live lamina length in the chronology of emergence of leaves first increased and reached a maximum sized leaf lamina than decreased in time (*Table 1*).

Table 1 Three year average size of the leaf lamina length in the chronology of leaf emergence

No. of leaves:	1	2	3	4	5	6	7	8	9	10	11
Lamina size cm:	11,35	16,63	19,40	22,86	25,20	26,32	21,87	16,85	11,30	12,00	12,04
Standard deviation:	3,55	2,68	4,58	4,19	3,94	1,98	5,57	5,90	5,78	8,05	5,89

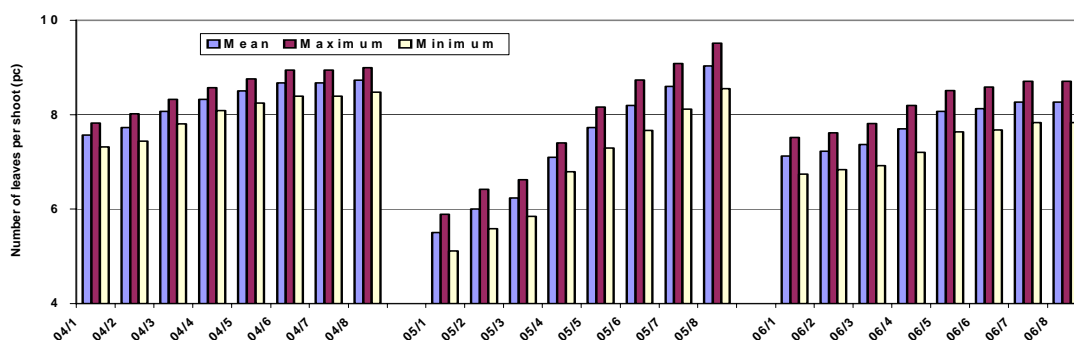

Figure 3. Total number of leaves per shoot of brome grass during primary growth

The total sum of the active leaf lamina lengths (SALL) per shoot mounted above 140 cm ( $s=34,61$  and  $s=45,00$ ) for 2004 and 2005 respectively, but was a bit lower (128,37 cm;  $s=21,97$ ) for 2006. There was no remarkable decrease in total leaf lamina length per shoot by

the end of the investigation period which means that brome grass was able to maintain its leafy character during the primary growth. The changes in the chemical composition of brome grass in spring showed the well known pattern. Crude protein, crude fat and crude ash contents, as well as net energy values, decreased remarkably in time. At the same time, crude fibre and N-free extract contents increased (Table 2). Differences are highly significant ( $P < 0.01$ ).

Table 2 Chemical composition of brome grass in spring (2004 and 2005)

2004		April	May	May	June	June	LSD <sub>5%</sub>
Sampling dates		20	4	11	1	14	
Crude protein*	g kg <sup>-1</sup> DM	268,8	182,5	154,4	109,3	85,1	6,94
Crude fat*	g kg <sup>-1</sup> DM	33,6	27,4	22,7	9,9	8,9	1,85
Crude fibre*	g kg <sup>-1</sup> DM	219,2	297,6	332,5	368,2	309,4	15,66
Crude ash*	g kg <sup>-1</sup> DM	123,5	106,7	84,2	72,0	52,3	3,74
N- free extract*	g kg <sup>-1</sup> DM	354,9	385,8	406,2	440,5	544,3	10,70
Ne <sub>m</sub> *	MJ kg <sup>-1</sup> DM	6,6	5,2	5,3	4,6	4,6	0,09
NE <sub>g</sub> *	MJ kg <sup>-1</sup> DM	4,1	2,8	3,0	2,2	2,3	0,07
NE <sub>l</sub> *	MJ kg <sup>-1</sup> DM	6,3	5,2	5,3	4,8	4,8	0,10

2005		April	May	May	May	June	June	LSD <sub>5%</sub>
Sampling dates		27	5	18	26	2	6	
Crude protein*	g kg <sup>-1</sup> DM	250,4	193,3	104,6	72,7	71,3	61,2	6,94
Crude fat*	g kg <sup>-1</sup> DM	22,1	30,8	26,1	19,9	20,7	22,2	1,85
Crude fibre*	g kg <sup>-1</sup> DM	247,9	245,8	296,3	404,1	393,3	323,3	15,66
Crude ash*	g kg <sup>-1</sup> DM	127,2	121,6	94,8	79,0	73,4	71,4	3,74
N- free extract*	g kg <sup>-1</sup> DM	352,5	408,6	478,2	424,3	441,3	522,0	10,70
Ne <sub>m</sub> *	MJ kg <sup>-1</sup> DM	6,5	6,6	5,2	4,5	4,6	4,6	0,09
NE <sub>g</sub> *	MJ kg <sup>-1</sup> DM	4,0	4,1	2,8	2,2	2,2	2,2	0,07
NE <sub>l</sub> *	MJ kg <sup>-1</sup> DM	6,2	6,2	5,2	4,8	4,8	4,8	0,10

\*  $P < 0.01$

## Conclusions

The results of phenological spring development and chemical composition of some other grasses (tall fescue, perennial ryegrass, timothy and reed canary grass) are under evaluation. Comparison of the exact chemical composition data will contribute to the more objective evaluation of these grasses.

## Acknowledgement

Research was financed by Hungarian National Scientific Foundation (OTKA T042506), meteorological data were provided by the local institutional observatory.

## References

- Dwayne R.B. and Merens D.R. (1995) Quality related characteristics of forages. In: Barnes R.F. *et al.* (eds.) Forages, The Science of Grassland Agriculture. Iowa State University Press, Ames, Iowa, USA, 83-96.
- Gill M., Beaver D.E. and Osbourn D.F. (1989) Feeding value of grass and grass products, In: Holmes, W. (ed.) Gras its production and utilization. BGS, Blackwell Scientific Publications. Oxford-London. 89-129.
- Nelson J.C. and Moser L.E. (1995) Morphology and Systematics, In: Barnes R.F. *et al.* (eds.) Forages, The Science of Grassland Agriculture. Iowa State University Press, Ames, Iowa USA, 15-30.
- Peeters A. (2005) *Lolium Perenne* L. In: Reynolds *et al.* (eds.) Grassland Species Profiles, Detailed descriptions and photos of more than 600 grassland species. CD-ROM, FAO, Rome.
- Robson M.J., Parsons A.J. and Williams, T.E. (1989) Herbage production: grasses and legumes. In: Holmes W. (ed.) Gras its production and utilization. BGS, Blackwell Scientific Publications, Oxford-London, 7-88.
- Vinczeffy I. (1991) Gyepgazdálkodási praktikum, Debreceni Agrártudományi Egyetem, Debrecen, 43-46.

# Early or late? New insights into the yield performance of perennial ryegrass (*Lolium perenne* L.) genotypes

Salama H., Lösche M., Herrmann A., Gierus M. and Taube F.

*University of Kiel, Grass and Forage Science/Organic Agriculture, Institute of Crop Science and Plant Breeding, D-24118 Kiel, Germany*

## Abstract

A field trial was conducted at three different sites in Northern Germany, during the growing season of 2006, to study the yield performance of twenty ryegrass genotypes (early, intermediate and late heading) as affected by two cutting regimes A and B. Results indicated that the 1<sup>st</sup> cut dry matter yield (DMY) was significantly affected by the different experimental sites and the two applied cutting regimes. It showed also a significant variability among the three maturity groups, where the early and intermediate groups produced significantly higher 1<sup>st</sup> cut DMY than the late group. The annual DMY for the three tested groups was significantly affected by the interaction between the three sites and the two cutting regimes. A significant superiority of the intermediate heading group over the late heading group was detected in the second site for cutting regime A and in the third site for cutting regime B.

Keywords: Perennial ryegrass, heading date, maturity group, yield performance

## Introduction

Grass maturity is an important factor affecting yield and quality in grassland based systems. The choice of the suitable maturity group to fit with the different growing purposes provides a strategic management tool to control forage supply throughout the year. In general, late maturing genotypes are recommended for grazing swards, while mixtures of early and late types are usually grown in cutting swards to ensure reasonable forage supply with each cut. In recent years, however, the introduction of seed mixtures consisting of mainly late-maturing cultivars is discussed intensively in Germany. Therefore, the main objective of the present study is to provide information concerning the yield performance of different perennial ryegrass maturity groups grown at different sites as affected by two cuttings regimes.

## Materials and methods

The present study was carried out at three different sites in Northern Germany during the 2006 growing season. A Randomised Complete Block Design was used in 2 replications. The dry matter yield (DMY) for twenty ryegrass genotypes as affected by two cutting regimes A and B were evaluated for the three sites. The twenty genotypes were classified into three maturity groups according to the days required to reach heading after 1<sup>st</sup> April: early heading group (44 to 49 days), intermediate heading group (50 to 55 days) and late heading group (56 to 62 days). Cutting regime A was applied at the heading of the earliest genotype, with a subsequent cutting interval of 5 weeks. Cutting regime B began two weeks later than regime A, with a cutting interval of 6-7 weeks. Applying these two cutting regimes resulted in five cuts from regime A and four cuts from regime B. Fresh herbage mass per plot was determined using a Haldrup plot harvester, cutting at 5 cm above ground level. A representative sub-sample of 400 g for each plot was dried at 58 °C for 24 hours and used to determine the



annual and the 1<sup>st</sup> cut DMY. Data were statistically analysed using the Mixed Procedure of SAS analysis. The least significant difference (L.S.D) procedure was used for mean comparison. The probabilities were adjusted according to Bonferroni-Holm Test.

## Results and discussion

The main results concerning 1<sup>st</sup> cut DMY are presented in Table 1 and indicate significant differences in the studied variable as affected by the interaction between the three sites and the two cutting regimes. Moreover, the same table revealed a significant variation among the three tested maturity groups.

Average values for 1<sup>st</sup> cut DMY (Table 2) indicate that cutting regime A in site 3 produced the lowest significant value (2.8 t ha<sup>-1</sup>). This was attributed to the very low temperature at this site before the harvesting time of the 1<sup>st</sup> cut in the cutting regime A from 1<sup>st</sup> to 20<sup>th</sup> May.

In addition, the early and intermediate maturity groups produced higher 1<sup>st</sup> cut DMY compared to the late group (Table 3). Average values were 6.1, 6.4 and 5.9 t ha<sup>-1</sup> for the early, intermediate and late groups, respectively. This pattern of herbage DMY corresponds to findings from other studies where varieties of perennial ryegrass differing in heading date are harvested at the same time in spring. In a study of Gilliland *et al.* (1995) the early heading types produced higher DMY compared to late heading types up to the time that they are heading and then the order was reversed. Berendonk (1984), Nekrosas (2003) and Laidlaw (2004 and 2005) reported similar results, stating that at the first harvest, in late April to middle May, the early maturing genotypes gave always the highest DMY and the late maturing genotypes gave the lowest.

Table 1. Analysis of variance for 1<sup>st</sup> cut dry matter yield (t DM ha<sup>-1</sup>) as affected by the two cutting regimes in the three sites.

Sources of Variation	DF	F Value	P > F
Sites (S)	2	31.63	0.0004
Cutting Regime (CR)	1	49.23	0.0003
Maturity Group(G)	2	9.45	0.0001
S * CR	2	17.73	0.0023
S * G	4	1.37	0.2437
CR * G	2	0.76	0.4691
S * CR * G	4	1.27	0.2841

Table 2. Mean values for 1<sup>st</sup> cut dry matter yield (t DM ha<sup>-1</sup>) as affected by the interaction between the three sites and the two cutting regimes.

Cutting regime	Site 1	Site 2	Site 3
A	6.4 a	6.6 a	2.8 b
B	7.5 a	7.0 a	6.7 a

Means followed by the same letter within the same column are not significantly different according to LSD test at 0.01 level of probability.

Table 3: Mean values for 1<sup>st</sup> cut dry matter yield (t DM ha<sup>-1</sup>) for the early, intermediate, and late maturity groups.

Maturity group	Mean 1 <sup>st</sup> cut DMY (t DM ha <sup>-1</sup> )
Early	6.1 ab
Intermediate	6.4 a
Late	5.9 b

Means followed by the same letter within the same column are not significantly different according to LSD test at 0.01 level of probability.

Furthermore, Gilliland *et al.* (2002) stated that the overall herbage DMY tended to be highest in early varieties towards the beginning of the season, but increased proportionally within later heading varieties as the season progressed.

The annual DMY varied significantly among the three maturity groups as affected by the interaction between the three locations and the two cutting regimes (Table 4). Data presented in Table 5 indicate that the intermediate heading group produced the highest significant annual DMY compared to the late heading group under cutting regime A when applied in site 2. The mean annual DMYs were 10.8, 11.1 and 10.2 t ha<sup>-1</sup> for the early, intermediate and late maturity groups, respectively.

Similar results were observed for cutting regime B in site 3, where the intermediate heading group of genotypes showed highly significant superiority to the other two groups with an average annual DMY of 18.7 t ha<sup>-1</sup>, against 16.6 and 17.0 t ha<sup>-1</sup> for early and late groups, respectively.

These findings partially agree with those of Smit *et al.* (2005), who found that in the 1<sup>st</sup> sampling year the intermediate heading genotypes produced higher DMY than the late heading genotypes. In the second sampling year the situation was reversed and they attributed this to the significant variation that was found among the varieties within the late heading group, while in the intermediate heading group, there were no differences between the varieties. Laidlaw (2004), in contrast, did not detect any significant differences in the DMY between three tested maturity groups in a 2-year study. This was attributed to the significant variation between the different ploidy levels within each group along the different cuts which hid the differences between the maturity groups in the overall annual DMY.

Table 4. Analysis of variance for annual dry matter yield (t DM ha<sup>-1</sup>) as affected by the two cutting regimes in the three sites.

Sources of Variation	DF	F Value	P > F
Sites (S)	2	31.01	0.0004
Cutting Regime (CR)	1	115.80	0.0001
Maturity Group (G)	2	10.79	0.0001
S * CR	2	50.51	0.0001
S * G	4	1.89	0.1125
CR * G	2	3.27	0.0397
S * CR * G	4	3.84	0.0049

Table 5. Mean values for annual dry matter yield (t DM ha<sup>-1</sup>) as affected by the interaction between the maturity group, site and cutting regime.

Maturity group	Site 1		Site 2		Site 3	
	Cutting regime A	Cutting regime B	Cutting regime A	Cutting regime B	Cutting regime A	Cutting regime B
Early	12.4 a	14.0 a	10.8 ab	11.3 a	10.3 a	16.6 b
Intermediate	12.2 a	13.5 a	11.1 a	11.9 a	10.1 a	18.7 a
Late	11.8 a	13.0 a	10.2 b	11.3 a	10.4 a	17.0 b

Means followed by the same letter within the same column are not significantly different according to LSD test at 0.01 level of probability.

## Conclusion

The results of the present investigation show significant differences in yield performance among early, intermediate, and late heading groups. The yield differences, however, were relatively small, which may be attributed to the small heading date differences, amounting to 18 days between early and late heading genotypes.

## Acknowledgments

Many thanks are due to Innovationsstiftung Schleswig-Holstein and Deutscher Akademischer Austausch Dienst (DAAD) for the financial support of this project.

## References

- Berendonk C. (1984) Yield, nutrient composition and digestibility of the organic matter of perennial ryegrass (*Lolium perenne* L.) varieties of different maturity groups, in pure and mixed sowing, in relation to first cutting date and cutting frequencies. 1. Yield of dry matter. D. wirtschaftseig. Futter 30, 139-148.
- Gilliland T. J., Barrett P. D., Mann R. L., Agnew R. E. and Fearon A. M. (2002) Canopy morphology and nutritional quality traits as potential grazing value indicator for *Lolium perenne* varieties. *J. Agr. Sci.*, 139: 257-273.
- Gilliland T. J., Camlin M. S. and Johnston J. (1995) Effect of harvest date and cultivar maturity on perennial ryegrass (*Lolium perenne* L.) yield and digestibility. *Irish J. Agr. Food Res.* 34, 133-142.
- Laidlaw A. S. (2004) Effect of heading date of perennial ryegrass cultivars on tillering and tiller development in spring and summer. *Grass Forage Sci.* 59, 240-249.
- Laidlaw A. S. (2005) The relationship between tiller appearance in spring and contribution to dry-matter yield in perennial ryegrass (*Lolium perenne* L.) cultivars differing in heading date. *Grass Forage Sci.* 60, 200-209.
- Nekrosas S. (2003) Comparison of early and late diploid breeding lines and varieties of perennial ryegrass. *Zemes-ukio-Mokslai* 3, 53-60.
- Smit H. J., Tas B. M., Taweel H. Z. and Elgersma A. (2004) Sward characteristics important for intake in six *Lolium perenne* varieties. *Grass Forage Sci.* 60, 128-135.

## Ecologo-genetic approach to perennial ryegrass breeding

Katova A.<sup>1</sup>, Baert J.<sup>2</sup>, Hristov K.<sup>1</sup> and Van Bockstaele E.<sup>3,4</sup>

<sup>1</sup> *Institute of Forage Crops, 89 Gen. Vladimir Vazov, 5800 Pleven, Bulgaria*

<sup>2</sup> *ILVO, Plant Genetics and Breeding, Caritasstraat 21, 9090 Melle, Belgium*

<sup>3</sup> *Gent University, Faculty of Bioscience Engineering, Coupure Links 653, 9000 Gent, Belgium*

<sup>4</sup> *ILVO, Burg. Van Gansberghelaan 96, 9820 Merelbeke Belgium*

### Abstract

Tandem selection was applied to combine high productivity and ecological stability in a perennial ryegrass breeding program. Four comparative field trials were carried out at the Institute of Forage Crops, Pleven, during 2002-2004. The genotype-environment interactions of 46 perennial ryegrass varieties and populations were tested under four environmental conditions simultaneously. The trials were conducted under both irrigated and rain-fed conditions, to test the effect of water deficiency on genotype productivity, and at two populations of plants, 125,000 and 62,500 plants per ha, to test the competitive ability of individual plants. The analysis of the generalized results for the distribution of the 46 perennial ryegrass genotypes showed an interesting regularity. The correlation between the yield potential and ecological stability was very strong. Promising directions for application of these ecologo-genetic approaches to the innovation in grass breeding were outlined, and in particular to the selection of genotypes for heterotic breeding.

Keywords: ecologo-genetical approach, perennial ryegrass, genotypes, tandem selection

### Introduction

The influence of the abiotic environmental factors is the main reason (71%) for the yield decrease (Acevedo and Fereres, 1993). During the past decades the main methods for decreasing environmental stress were modification of the environment by irrigation, tillage, fertilization, etc. Currently the economic and ecological demands for the protection of the environment are the reasons for using the genetic improvement of stress resistance as a possible alternative to narrowing the gap between actual and potential yield under limiting environments. Selection of superior genotypes with a wide adaptation across large complex environments or with specific adaptation to regional environments is an important issue for plant breeders (Maxwell *et al.*, 2006). The most studied forage grass in the world is perennial ryegrass (Peeters, 2004). It is of great importance to perennial ryegrass breeding in Bulgaria that high productivity combines with ecological stability under limiting environmental conditions (e.g. drought and cold) (Katova, 2005, Katova *et al.*, 2006). The aim of this study was ecologo-genetic screening and tandem selection (high productivity and high ecological stability) of perennial ryegrass genotypes related to sustainable agriculture under variable climates.

### Materials and methods

Four comparative field trials were carried out at the Institute of Forage Crops, Pleven, during 2002-2004. The genotype-environment interactions of 46 perennial ryegrass varieties and populations were tested under four environmental conditions simultaneously. Specifically, the

trials were conducted under both irrigated and rain-fed conditions, to test the effect of water deficiency on genotype productivity, and at two plant populations, 125,000 and 62,500 plants per ha, to test the competitive ability of individual plants. Genetically, varieties and populations were distinguished by maturity group (early [E, n = 19], intermediate [I, n = 21] and late [L, n = 6]), ploidy level (diploid [D, n= 28] and tetraploid [T, n = 18]) and origin (Bulgaria, Romania, Denmark, United Kingdom, Belgium and the Netherlands). Different numbers of cuts were applied in the second (2003) and third (2004) years of production. A total of 80 individual plants per variety were measured for dry matter (DM) productivity following the method of Dragavtsev (2005). The genotype and variety behaviour was estimated after Eberhart and Russel (1966) using a calculative table in Excel (Hristov, unpublished). ANOVA was made by Analysis Toolpak in Excel. Coefficient of linear regression (stability coefficient) ( $b_i$ ), dispersion around regression line (sum of squares deviation) ( $S_i^2$ ) and F-criteria were calculated for each variety to measure the ecological stability.

## Results and discussions

The dispersion analysis (ANOVA) showed a significant interaction between genotypes and environments (Table 1) for all maturity groups and allowed an ecologo-genetic analysis of the data following the method of Eberhart and Russel (1966).

Table 1. Two – way ANOVA analysis for the perennial ryegrass cultivars and genotype-environment interactions for all maturity group cultivars.

Source of Variation	SS	df	MS	F	P-value	F critical
Genotypes	305520	46	6641.74	15.37	8E-94	1.37
Environments	1818606	29	62710.56	145.10	0	1.48
Interactions	1008984	1334	756.36	1.75	3E-25	1.09
Errors	609389.1	1410	432.19			
Total	3742499	2819				

Significant differences were found in forage DM productivity and in the stability parameters over environments (Table 2). Unstable genotypes were those with  $S_i^2$  significantly deviating from the regression line and  $b_i$  higher than 1 and they were responsive to favourable conditions and suitable for intensive farm system. The genotype which had  $b_i = 1$  and  $S_i^2 = 0$  was assumed to be 'ideal'. If the value of  $b_i$  was lower than 1, the genotype may be stable in unfavourable conditions and suitable for extensive low input farm systems. Breeding is directed to the selection of genotypes which combine high productivity with a  $b_i$  value than 1 between 0.7 and 1 (Christov *et al.*, 2002). This research displayed a great variation for the two parameters. The correlation between the yield potential and ecological stability was very strong ( $r = 0.8557$ ).

The average DM productivity (g per plant) from all environments varied across genotypes and varieties from 27.19 to 68.81 (Table 2). Tetraploid varieties of intermediate and late maturity groups were mainly within the 10 most productive varieties. The regression coefficient  $b_i$  ranged from 0.35 to 2.18 (Figure 1). The productivity was increased three times and stability was decreased six times. The most productive varieties were responsive to environmental improvement but were unstable ( $b_i > 1$ ). Therefore, ecological stability was lost in the breeding process for these varieties and the breeding objective should be its improvement so that the variety growing can be successful under water deficiency. The variety Roy was the most productive but it had also the highest coefficient of regression ( $b_i = 2.18$ ) which indicates that it is unstable in unfavourable conditions. The varieties Ernesto and Fetionne

were highly productive and stable ( $b_i = 1$ ), and Aubisque was highly productive and stable in unfavourable conditions ( $b_i = 0.74$ ).

Table 2. Estimation of ecological stability of perennial ryegrass cultivars for dry matter (DM) productivity (2003-2004) and ranked by average DM productivity over all environments ( $\bar{x}_i$ ).

Varieties and populations	Maturity group (E, I, L)*	Ploidy level (D,T)*	Average DM productivity ( $\bar{x}_i$ ) (g plant <sup>-1</sup> )	Coefficient of linear regression ( $b_i$ )	Ecological stability ( $S_i^2$ )	Significance F-criteria
1. Roy	I	T	68.81	2.18	3921.62	272.21
2. Pandora	I	T	65.65	2.06	4300.31	298.50
3. Merkator	L	T	63.21	1.92	1206.48	83.75
4. Merkem	L	T	62.12	1.80	3592.09	249.34
5. Abercraigs	I	T	59.98	1.88	1466.48	101.79
6. Elgon	I	T	58.06	1.48	1059.72	73.56
7. Ernesto	L	T	56.46	0.95	2340.55	162.47
8. Vigor	L	D	54.50	1.75	886.93	61.56
9. Aubisque	I	T	53.74	0.74	-202.05	-14.02
10. Veritas	L	D	53.02	1.47	203.51	14.13
11. Syn I	I	D	52.13	1.22	2699.61	187.39
12. Fetione	I	T	50.13	0.99	344.44	23.91
13. Merlinda	I	T	48.00	1.38	4086.94	283.69
14. Svishtov	E	D	47.62	1.54	2736.45	189.95
15. Pomerol	L	T	46.20	0.65	2664.20	184.93
16. Ritz	I	D	46.00	1.25	2594.51	180.09
17. Foxtrot	I	D	44.47	0.84	3281.19	227.76
18. Lasso	I	D	43.76	0.88	1077.46	74.79
19. Slaviyany	I	D	42.98	1.37	1026.72	71.27
20. Cancan	I	D	42.65	1.02	4303.45	298.72
21. Barmetria	I	D	42.04	1.02	1603.41	111.30
22. Vabel	E	D	40.74	0.90	1540.81	106.95
23. Barlet	I	D	40.51	0.99	-2381.01	-165.28
24. Varna	E	D	39.66	1.26	3716.58	257.98
25. Syn III	E	T	39.63	0.85	313.56	21.77
26. Isabel	I	D	39.49	0.70	117.49	8.16
27. Odessa	I	D	39.39	0.71	-769.18	-53.39
28. Belene	E	D	38.56	1.22	2262.41	157.04
29. Sredec	E	D	38.24	0.91	1697.76	117.85
30. Mara	I	T	38.21	0.44	-6193.30	-429.90
31. Plenty	I	D	37.22	0.65	508.07	35.27
32. Abereclair	E	T	37.03	0.88	702.51	48.76
33. Balgarene	E	D	36.83	0.79	2331.83	161.86
34. Marta	E	D	36.68	0.49	1410.31	97.89
35. Syn II	I	D	36.34	0.49	351.75	24.42
36. Devnya	E	D	35.45	1.05	5209.44	361.61
37. Meretti	E	T	34.81	0.76	810.46	56.26
38. Rebecca	E	D	34.72	0.80	352.24	24.45
39. Targovishte	E	D	34.37	0.64	604.73	41.98
40. Barfort	I	D	33.61	0.35	-1883.62	-130.75
41. Anacoda	E	T	33.40	0.79	1070.05	74.28
42. Tetramax	E	T	32.64	0.43	640.22	44.44
43. Moy	E	D	29.12	0.47	422.71	29.34
44. Syn IV	E	D	28.36	0.52	295.06	20.48
45. Labrador	E	T	27.46	0.51	1137.16	78.93
46. Abergold	E	D	27.19	0.57	206.00	14.30
Average			43.05	1.00	1291.43	89.64

\*E – early, I – intermediate, L – late; \*D - diploid, T - tetraploid

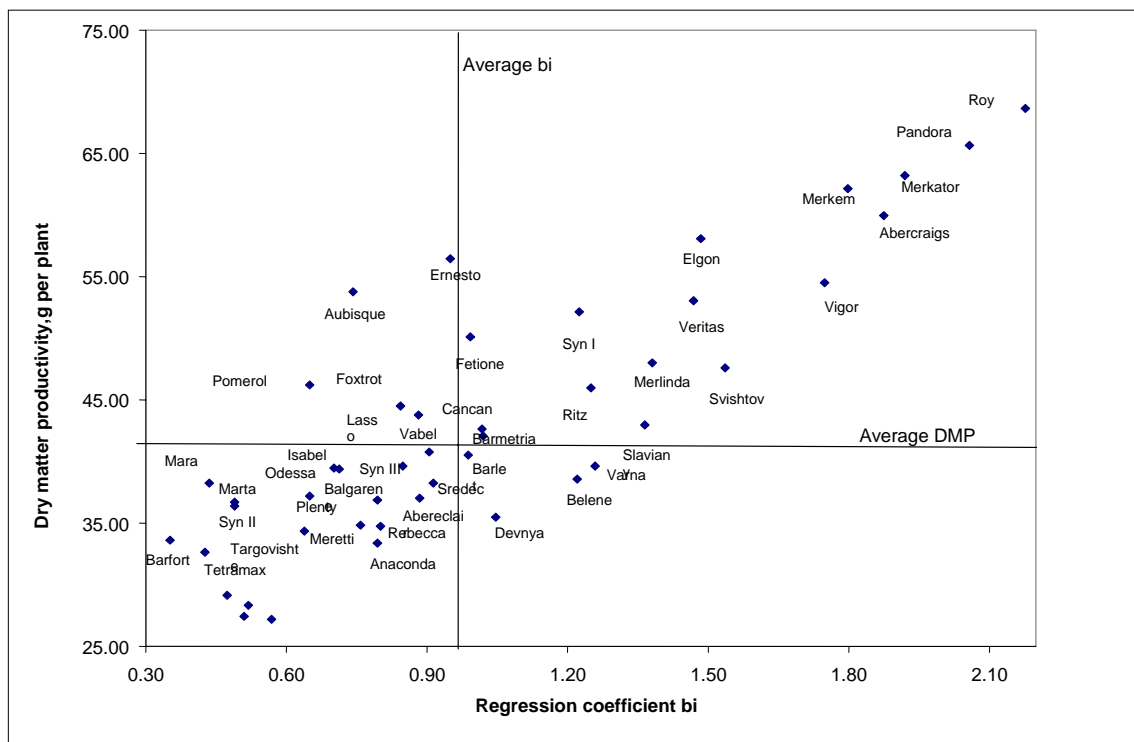

Figure 1. Distribution of perennial ryegrass varieties by dry matter productivity ( $\text{g plant}^{-1}$ ) and ecological stability (bi).

## Conclusions

The application of directionally created limited environmental conditions provides a possibility for identification of genotype by phenotype without changing the generations. Promising directions for application of these ecologo-genetic approaches to the innovation in grass breeding were outlined, and in particular to the selection of genotypes for heterotic breeding. The yield value and stability are determined by different genetic bases and breeding aimed at combining these two parameters could be successful. The varieties with the highest ecological stability can spread in a wider ecological area.

## References

- Acevedo E. and Fereres E. (1993) Resistance to abiotic stresses In: *Plant Breeding : Principles and prospects*, Edited by M.D. Hayward, N.O. Bosermark and I. Romagosa, , Chapman and Hall, London, 406 - 413.
- Dragavtsev V.A (2005) New method of ecologo-genetical analysis quantitative polygene traits in plants SPb.: VIR, 30.
- Christov N., Christov I. and Christov K. (2002) The model of ecologo-genetical organization of complex quantitative traits for productivity, resistance and quality in plants, *Biotechnology and Biotechnological Equipment* 16, 2, 36 – 46.
- Eberhart S. A. and Russell W. A. (1966) Stability parameters for comparing varieties, *Crop Science*, 6, 36 – 40
- Katova, A. (2005) Study of morphological traits, biological properties and agricultural value of plant germplasm of perennial ryegrass (*Lolium perenne* L.) with a view to breeding, PhD thesis, Sofia, 141p.
- Katova A., Hristov K., Baert J. and Van Bockstaele E. (2006) Ecologo-genetical estimation of perennial ryegrass (*Lolium perenne* L.) European cultivars and local populations in Bulgaria, In: *Sustainable Grassland Productivity – Proceedings of the 21<sup>st</sup> General Meeting of the EGF*, Badajoz, Spain, 3-6 April 2006, 158 – 160.
- Maxwell J., Murphy P. and Bockelman H. (2006) Selection for adaptability in multy-environmental trials, ASA-CSSA-SSSA International annual meeting, Indianapolis, November 12-16, 58-1.
- Peeters A. (2004) Wild and Sown Grasses. Publ. FAO, Rome, 2004, pp.311.

# Yield, persistence and forage quality of some grass and legumes species under central European conditions

Kohoutek A.<sup>1</sup>, Carlier L.<sup>2</sup>, Zimková M.<sup>3</sup>, Odstrčilová V.<sup>1</sup>, Nerušil P.<sup>1</sup> and Komárek P.<sup>1</sup>

<sup>1</sup>*Crop Research Institute Prague 6 - Ruzyně, Research Station Jevicko, K. H. Borovskeho 461, 569 43 Jevicko, the Czech Republic*

<sup>2</sup>*CLO, Department Crop Husbandry and Ecophysiology, Burg Van Gansberghelaan 109, B-9820 Merelbeke, Belgium*

<sup>3</sup>*SARC, Grassland and Mountain Agriculture Research Institute, Mladeznicka 36, 974 21 Banská Bystrica., Slovakia*

## Abstract

Yield and persistence of Belgian varieties of two legume and four grass species were compared with Czech varieties at Jevíčko in the Czech Republic (CR): five varieties of *Trifolium pratense*, three varieties of *Trifolium repens*, eight varieties of *Lolium perenne*, two varieties of *Dactylis glomerata*, two varieties of *Festuca pratensis* and two varieties of *Phleum pratense*. The trials were established by grassland renovation in 1992 (335 m a. s. l., average temperature 7.5 °C, average annual precipitation 629 mm). Legume and grass species were sown as monocultures. Grasses were fertilised with 150kg N +35kg P +100kg K.ha<sup>-1</sup>, legumes by 35kg P +100kg K.ha<sup>-1</sup> and cut three times per year. Evaluation comprised determination of dry matter production, botanical composition of the stand and forage quality i.e. NEV (net energy of fattening), NEL (net energy of lactation), crude protein (CP) and crude fibre (CF) predicted by NIRsystems 6500. *L. perenne*, *D. glomerata* *F. pratensis* and *T. pratense* gave the highest yields. Medium yielding were *P. pratense* and *T. repens*. The most persistent was *D. glomerata* (>16 years), *P. pratense* was persistent for 11 years, *F. pratensis* was persistent for three to five years depending on variety and both clovers for three years. Belgian and Czech varieties had similar yields and persistence. Belgian clover and grass varieties performed well under central European conditions due to their high sward productivity and persistence and in case of *D. glomerata* due to its very good winter hardiness. Thus they make a valuable contribution to the range of forage plant species and varieties suitable for the Czech Republic.

Keywords: grasses, legumes, yield, persistence, forage quality, NIRS analysis

## Introduction

Persistence and production of clovers and grasses differ considerably not only between species but also between varieties and so they need to be tested for their suitability for different conditions. As dairy cow milk production has increased in the Czech Republic from 3,932 to 6,254 kg FCM between 1989 and 2005, higher quality forages are required. This paper reports on the suitability of native and foreign high- quality varieties to meet this aim of higher milk production in central Europe.

## Materials and methods

Yield and persistence of Belgium varieties (B) of two legume and four grass species were compared with Czech varieties (C) in field trials at Jevíčko in the Czech Republic (CR): five varieties of *Trifolium pratense* (C – Tempus 4n, Start 2n; B – Merviot 2n, Violeta 2n, Rotra



4n), three varieties of *Trifolium repens* (C Pastevec, Hájek; B - Merwi), eight varieties of *Lolium perenne* (C - Tarpan 4n, Bača 2n, Mustang 4n; B - Merlinda 4n, Melino 2n, Meltra 4n, Vigor 2n, Merganda 4n), two varieties of *Dactylis glomerata* (C - Niva; B - Lemba), two varieties of *Festuca pratensis* (C - Otava; B - Merifest) and two varieties of *Phleum pratense* (C - Větrovský; B - Erecta). The trials were established by grassland renovation in 1992. The site was fluvisoil soil type, pH 6.7, 335 m a. s. l., average temperature 7.5 °C, average annual precipitation 629 mm). Legume and grass species were sown as monocultures. Grasses received 150kgN +35kgP +100kgK.ha<sup>-1</sup> and legumes 35kgP +100kgK.ha<sup>-1</sup> (as elements) and swards were cut three times per year. Forage production was evaluated as dry matter (DM) and corrected dry matter (CDM) production. CDM production was the yield of sown species calculated from the total dry matter production multiplied by the percentage contribution of sown species (from botanical analyses of the sward before cutting), divided by 100. Quality of forage dry matter in 1995-2006 was evaluated by NIR Systems 6500 fitted with a spinning sample module, in reflectance range 1100-2500 nm, band width 2 nm, measured in small ring cups, duplicate samples scanned twice. The parameters measured were crude protein (CP), fibre (CF), NEL (net energy of lactation), NEV (net energy of fattening), using software WinISI II, vers. 1.50. Differences between means were tested for significance by analysis of variance and the Tuckey test.

## Results and discussion

DM and CDM production of *Trifolium pratense* and *T. repens* is given in Table 1. Production of Belgian varieties was comparable or higher to that of Czech varieties, production of cv. Merviot being the highest. *T. pratense* persisted for three years and then declined. *T. repens*, cv. Merwi was higher yielding than Czech varieties Pastevec and Hájek in both DM and CDM production over four years (sowing year + 3 harvesting years). Merwi produced 5.32 DM and 1.66 t.ha<sup>-1</sup> CDM, while Pastevec and Hájek yielded 4.73 (1.26) and 4.70 (1.45 t.ha<sup>-1</sup> CDM), respectively.

Table 1. DM and CDM production of *Trifolium pratense* and *Trifolium repens* (t ha<sup>-1</sup>) in 1992-1995

<b>Trifolium pratense</b>			<b>Trifolium repens</b>		
Variety	DM t.ha <sup>-1</sup>	CDM t.ha <sup>-1</sup>	Variety	DM t.ha <sup>-1</sup>	CDM t.ha <sup>-1</sup>
Tempus	6.37	3.90	Pastevec	4.73	1.26
Start	6.42	3.22	Hájek	4.70	1.45
Merviot	7.00	4.14	Merwi	5.32	1.66
Violeta	6.41	3.74			
Rotra	6.88	4.12			
D <sub>T0.05</sub>	1.52	1.13	D <sub>T0.05</sub>	0.74	0.33
D <sub>T0.01</sub>	1.97	1.46	D <sub>T0.01</sub>	1.08	0.49

*Lolium perenne* (Table 2) was evaluated during 1992-1998, until the most persistent variety disappeared from the sward. All varieties had similar yields except the Belgian varieties Vigor and Merganda due to their higher persistence, especially in the two last years of the trial. All *L. perenne* varieties had similar forage quality, including energy concentration. In the Czech Republic, *L. perenne* is sown in swards to last for 2-3 years only because it does not withstand severe winters and a long period of snow cover.

Table 2. DM and CDM production of *Lolium perenne* (t.ha<sup>-1</sup>) in 1992-1998 and forage quality parameters in 1995-1998

Variety	1992 - 1998		1995 - 1998			
	DM	CDM	CP	CF	NEL	NEV
	t.ha <sup>-1</sup>	t.ha <sup>-1</sup>	g.kg <sup>-1</sup>	g.kg <sup>-1</sup>	MJ.kg <sup>-1</sup>	MJ.kg <sup>-1</sup>
Tarpan	6.59	4.35	145	217	5.85	5.75
Bača	7.34	4.61	139	234	5.74	5.60
Mustang	7.15	4.88	144	226	5.79	5.67
Merlinda	7.03	4.39	140	224	5.76	5.64
Melino	7.17	4.70	143	232	5.83	5.71
Meltra	6.90	4.38	142	222	5.81	5.70
Vigor	7.04	5.19	142	228	5.73	5.59
Merganda	7.21	5.22	140	223	5.80	5.68
D <sub>T0.05</sub>	0.69	0.73	17	15	0,17	0,20
D <sub>T0.01</sub>	0.84	0.90	21	18	0,20	0,24

*Dactylis glomerata* (Table 3) has been evaluated since 1992 (sowing year), being the most persistent and productive species in Czech Republic. Varieties Niva and Lemba had similar production and persistence, i.e. DM (and CDM) production of 8.45 (6.00) and 7.98 (5.91) t.ha<sup>-1</sup>, respectively. Both varieties survived a rapid and severe decline in temperature in January 2003, when it dropped 28°C in 48 hours because of ingress of arctic air. Swards gradually improved, reaching a level of production by 2006 similar to that before the severe frost. Other species in the same trials had a similar reaction (Kohoutek, 2006). Both cultivars had similar forage quality and energy concentration.

Table 3. DM and CDM production of *Dactylis glomerata* (t.ha<sup>-1</sup>) in 1992-2006 and forage quality parameters in 1995-2006

Variety	1992 - 2006		1995 - 2006			
	DM	CDM	CP	CF	NEL	NEV
	t.ha <sup>-1</sup>	t.ha <sup>-1</sup>	g.kg <sup>-1</sup>	g.kg <sup>-1</sup>	MJ.kg <sup>-1</sup>	MJ.kg <sup>-1</sup>
Niva	8.45	6.00	141	250	5.77	5.62
Lemba	7.98	5.91	145	248	5.72	5.56
D <sub>T0.05</sub>	0.63	0.53	16	13	0,06	0,07
D <sub>T0.01</sub>	1.16	0.98	29	24	0,11	0,14

*Phleum pratense* (Table 4) was evaluated in 1992-2004, until it definitely declined from the sward. It is the medium persistent species in the Czech Republic with medium persistence, surviving in the sward for 5-7 years. The Belgian variety Erecta had higher CDM production than the Czech variety Větrovský: 4.17 and 3.37 t.ha<sup>-1</sup>, respectively although they had the same DM production 8.37 t.ha<sup>-1</sup>. Erecta had higher CDM due to its higher persistence in 2000-2003. In 2004 measurements ceased as both varieties definitely declined from the sward. Both had similar forage quality and energy concentration.

*Festuca pratensis* (Table 5) was evaluated during 1992-2000 as a medium persistent species. Comparison of the Belgian variety Merifest and Czech variety Otava showed the better DM and CDM for cv. Merifest: 8.21 (2.99) and 7.65 (2.15 t.ha<sup>-1</sup>), respectively. Both cultivars persisted for 5 years, although during the latter 3 years (i.e. years 6 - 8) their presence was variable. Their productivity may have been influenced by their different growth development. Otava as a medium-late variety produced less than the earlier Merifest (above means for 1992 - 2000), but had higher forage quality and energy concentration than Merifest.

Production and persistence of Belgian varieties were tested in simple mixtures in an upland region of Slovakia in 1993-1995. The two-component mixtures (Merlinda/Merwi, Merganda/Merwi, Merifest/Merwi and Lemba/Merwi) produced good DM yields: 7.71, 7.38,

4.82 and 4.33t.ha<sup>-1</sup>, respectively. The most productive were ryegrass/white clover mixtures (Zimkova,1997).

Table 4. DM and CDM production of *Phleum pratense* (t.ha<sup>-1</sup>) in 1992-2004 and forage quality parameters in 1995-2004

Variety	1992 - 2004		1995 - 2004			
	DM t.ha <sup>-1</sup>	CDM t.ha <sup>-1</sup>	CP g.kg <sup>-1</sup>	CF g.kg <sup>-1</sup>	NEL MJ.kg <sup>-1</sup>	NEV MJ.kg <sup>-1</sup>
Větrovský	8.37	3.37	128	253	5.73	5.58
Erecta	8.37	4.17	126	245	5.78	5.65
D <sub>T0.05</sub>	0.40	0.85	17	19	0,18	0,24
D <sub>T0.01</sub>	0.73	1.56	31	35	0,33	0,43

Table 5. DM and CDM production of *Festuca pratensis* (t.ha<sup>-1</sup>) in 1992-2000 and forage quality parameters in 1995-2000

Variety	1992 - 2000		1995 - 2000			
	DM t.ha <sup>-1</sup>	CDM t.ha <sup>-1</sup>	CP g.kg <sup>-1</sup>	CF g.kg <sup>-1</sup>	NEL MJ.kg <sup>-1</sup>	NEV MJ.kg <sup>-1</sup>
Otava	7.65	2.15	142	233	5.75	5.61
Merifest	8.21	2.99	134	240	5.70	5.56
D <sub>T0.05</sub>	0.51	0.22	6	9	0,08	0,12

## Conclusion

Belgian clover and grass varieties demonstrate very good forage productivity and persistence under Czech conditions and, in the case of *D. glomerata*, also very good winter hardiness, comparable with native Czech varieties. They make a valuable contribution to the range of forage species and varieties suitable for the Czech Republic and Slovakia.

## Acknowledgements

The work reported in this paper was part of research project No. VZ00027006 ‘Creation, calibration and validation of sustainable and productive cropping systems’.

## References

- Kohoutek A., Odstrčilová V., Komárek P. and Nerušil P. (2006) Persistence and production ability of *Dactylis glomerata* L., *Dactylis polygama* Horvat, *Festuca arundinacea* L. and genus hybrids in 1986-2004. In *The Role of Long-term Field Experiments in Agricultural and Ecological Sciences and Practical Solutions for Managing Optimum C and N Content in Agricultural Soils III*, Prague, June 22nd – 24th 2005, 121-124. ISBN 80-213-1454-0.
- Zimkova M. (1997) Production and persistence of grass/white clover mixtures without fertilizer inputs in Central Slovakia. In *Seeds of Progress*. Ed.:Weddell, J.R. *BGS Occasional Symposium no 31*. Nottingham, February 18-19, 1997, 58-60. ISBN 0 905944 49 6.

# Systems for improvement of *Nardus stricta* subalpine grasslands from Carpathian Mountains

Marusca T., Mocanu V., Blaj V. and Hermenean I.

*Grassland Research and Development Institute 5 Cucului Str. 500128- Brasov, Romania*

## Abstract

The grasslands dominated by *Nardus stricta* species in Romanian Carpathians extend over 300 thousand hectares, at 400 – 2200 m altitude on acid soils, replacing more valuable grasslands, especially those of *Agrostis capillaris* and *Festuca rubra*.

Experiments concerning the improvement of *Nardus stricta* pastures, situated at 1800 m altitude in subalpine level of juniper (*Pinus mugo*) were carried out in Bucegi Massif of the Meridional Carpathians, during 1995 – 2006.

The experimental plots were situated on three vegetation cover types: natural, oversowing and resowing, with and without liming at 2/3 A<sub>h</sub> soil, with CaO and with mineral fertilization: PK, NPK and organic fertilization by package with sheep were applied at all treatment combinations. The paper presents dry matter (DM) yield, botanical composition, agricultural soil composition. The effect of soil liming over 10 years and of package over 5 years on the DM yield and botanical composition is shown. Organic fertilization is better than mineral fertilization, because the perennial legumes are stimulated. The pastoral value of degraded sward of *Nardus stricta* increases from 18 (low) to 81 (very high) at limed, packaged and oversowed variants.

Key words: *Nardus stricta* sward, liming, fertilization, oversowing, resowing

## Introduction

The improvement and utilization of degraded grasslands dominated by *Nardus stricta* in Carpathian Mountains has been little studied (Marusca and Frame, 2003). Extreme climatic conditions, short periods of vegetation growth, acid soil with rocks at the surface all restrict DM production and herbage quality utilized by animals. Methods for improving vegetal cover in the highlands altitude differ from those in the lowlands. (Barbulescu and Motca, 1983). Also, in these conditions, the use of biological agriculture may be recommended to avoid pollution of the environment.

## Material and methods

The experiment was carried out in the Meridional Carpathians in the subalpine zone of *Pinus mugo* of Bucegi Massif at 1800 m altitude on grassland dominated by *Nardus stricta*, situated on acid soils, with low supply of phosphorus and potassium. The treatments of this experiment were:

A factor – fertilization: a<sub>1</sub> – mineral fertilization 50 P<sub>2</sub>O<sub>5</sub>+50 K<sub>2</sub>O, kg/ha; a<sub>2</sub>- mineral fertilization 150N+50P<sub>2</sub>O<sub>5</sub> +50K<sub>2</sub>O; a<sub>3</sub>- package with sheep ( 5 nights, 1 sheep m<sup>-2</sup>), two times in this period (1996 and 2000 years).

B- factor- vegetation cover type: a<sub>1</sub>- natural cover; a<sub>2</sub>- oversowing; a<sub>3</sub>. resowing

C factor- liming: c<sub>1</sub>- unlimed; c<sub>2</sub>- limed at 2/3 A<sub>h</sub>. Oversowing and resowing were done in spring of 1996 following destruction of the degraded cover in 1995 with Roundup application (5 L ha<sup>-1</sup>), liming for neutralization of the 2/3 A<sub>h</sub> (hydrolitic acidity) and package with sheep.

Before the sowing, the soil was worked with harrow at depth of 2-3cm for the oversown treatments and a rotary milling machine at the depth of 10-12cm for the resowing treatments. These treatments were then sown using seed mixtures of *Phleum pretense* cv. Favorit, *Festuca pratensis* cv. Transilvan, *Lolium perenne* cv. Marta, *Trifolium hybridum*- local population of Brasov and *Lotus corniculatus* cv. Livada. Because *Festuca rubra*, *Poa pratensis* and *Trifolium repens* species grow in the spontaneous flora they were not sown. Harvested plots were of 18m<sup>2</sup> (3x6), in four replicates, in randomized blocks. Harvesting for assessment of DM yield and forage quality was made on 2m<sup>2</sup> from each plot, the rest being grazed by dairy cows. Botanical composition was assessed by the Klapp- Elenberg method, only once at the end of July and the beginning of August.

## Results and discussion

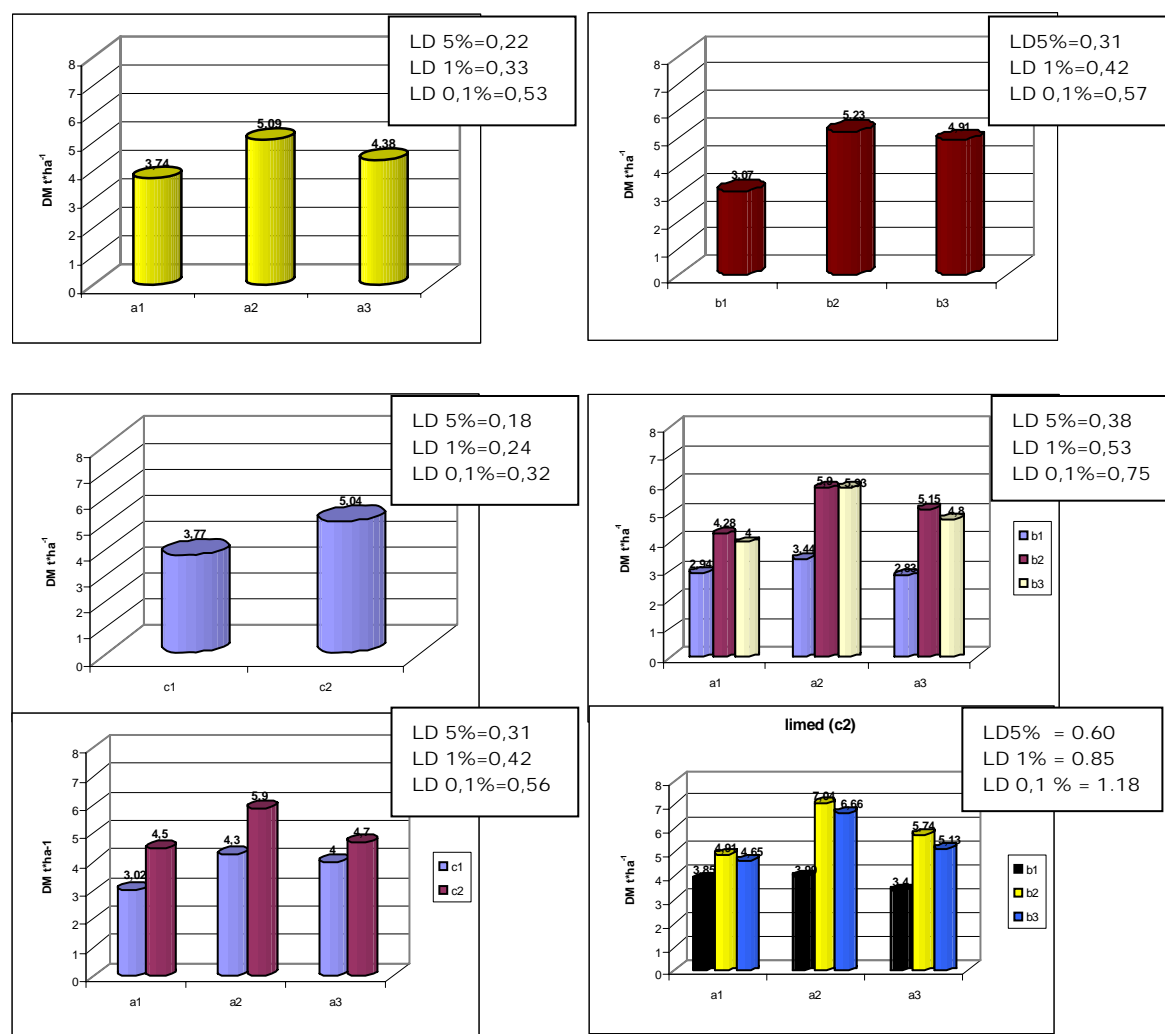

Figure 1: Variation of DM yield as a function of the experimental factors (mean 1997-2006) (a<sub>1</sub>-fertilisation PK; a<sub>2</sub>-fertilisation NPK; a<sub>3</sub>-pacage with sheep);(b<sub>1</sub>-natural cover; b<sub>2</sub>-oversowing; b<sub>3</sub>-resowing); (c<sub>1</sub>-unlimed ; c<sub>2</sub>-limed)

As result of variance analysis (F test) DM yield was significantly affected by A,B,C, factors and interactions between Ax B; Ax C and Ax Bx C. The highest DM yields were obtained with the treatment which combined lime (c<sub>2</sub>), mineral fertilizer NPK (a<sub>2</sub>) and oversowing (b<sub>2</sub>)

which gave an average yield over the ten years of 7.04 t/ha. Oversowing gave the highest yields with all of the fertilizer and lime treatments (Figure 1). These results are in line with those of previous research carried out on *Nardus stricta* grasslands in Carpathian Mountains which showed that after five years the highest DM yield were obtained on limed and oversown treatments (Marusca, 1977). The best treatment from the economical point of view appeared to be the limed treatment with applied herbicide and oversowing. This achieved a very high pastoral value with 65% sown species (Table 1). Liming changed substantially the agri-chemical characteristics of soil such as the pH with 0.7 units even after ten years from application (Table 2).

Table 1: Botanical composition and mean forage value (After Barbulescu and Motca method, 1983), Bucegi Mountain (1997–2006)

Species	Index forage value, %	(Sown) 1996 Natural 1995	b <sub>1</sub> Natural		b <sub>2</sub> Oversowing		b <sub>3</sub> Resowing	
			C <sub>1</sub> Un-liming	C <sub>2</sub> liming	C <sub>1</sub> Un-liming	C <sub>2</sub> liming	C <sub>1</sub> Un-liming	C <sub>2</sub> liming
			Sown					
<i>Phleum pratense</i>	5	(30)	.	.	24	34	14	30
<i>Festuca pratensis</i>	5	(40)	.	.	5	9	7	11
<i>Lolium perenne</i>	5	(10)	.	.	2	3	5	5
<i>Trifolium hybridum</i>	4	(5)	.	.	13	19	9	18
<i>Lotus corniculatus</i>	3	(15)	.	.	+	+	+	+
Spontaneous								
<i>Agrostis capillaris</i>	3	+	1	1	20	11	47	18
<i>Agrostis rupestris</i>	1	12	7	6	5	2	3	1
<i>Anthoxanthum odoratum</i>	1	+	1	+	+	+	+	+
<i>Deschampsia flexuosa</i>	1	3	13	9	6	3	2	+
<i>Festuca ovina</i>	1	8	8	9	2	1	+	+
<i>Festuca nigrescens</i>	3	+	3	3	4	1	1	2
<i>Phleum alpinum</i>	2	+	6	5	1	+	+	+
<i>Poa media</i>	1	17	12	8	3	1	4	1
<i>Poa pratensis</i>	4	.	+	6	.	1	+	2
<i>Nardus stricta</i>	0	40	9	3	1	.	.	.
<i>Trifolium repens</i>	4	8	13	21	8	12	6	10
<i>Campanula napuligera</i>	0	+	1	3	1	+	+	+
<i>Geum montanum</i>	0	+	+	1	+	+	+	+
<i>Hieracium aurantiacum</i>	0	+	1	1	+	+	+	+
<i>Ligusticum mutelina</i>	2	7	18	14	2	1	+	1
<i>Polygonum bistorta</i>	1	.	+	1	.	+	+	+
<i>Potentilla ternata</i>	1	4	5	5	3	1	2	1
<i>Taraxacum officinale</i>	2	.	1	2	+	1	+	+
<i>Viola declinata</i>	0	+	+	+	+	+	+	+
Forage value	x	18	32	40	67	81	69	83
Assesement	x	Low	Medium	Medium	High	Very high	High	Very high

Table 2: Changes of agri-chemical characteristics after improvement of subalpine grasslands  
-Bucegi Mountain, 1800 m alt. -

Characteristics	MU	1996	2006 after ten years					
		Before of improvement	b1(natural)		b2(oversowing)		b3(resowing)	
			C <sub>1</sub>	C <sub>2</sub>	C <sub>1</sub>	C <sub>2</sub>	C <sub>1</sub>	C <sub>2</sub>
pH în H <sub>2</sub> O	ind	4.65	4.83	5.25	4.82	5.35	4.83	5.43
Al <sup>3+</sup>	mg/100 g	3.94	4.03	0.25	3.90	0.44	4.02	0.54
V <sub>Ah</sub>	%	21.8	22.0	38.9	23.0	43.1	24.7	48.3
Humus	%	15.9	14.8	14.5	13.9	13.8	15.8	15.6
IN	ind	3.47	3.26	5.64	3.20	5.95	3.90	7.53
P – AL	ppm	19.8	17.8	16.4	16.7	15.8	14.3	14.0
K - AL	ppm	90	113	105	97	96	90	82

C<sub>1</sub> unlimed ; C<sub>2</sub> - limed

The results demonstrated the influence of oversowing and liming on DM yield and sward composition of subalpine grasslands in Carpathians. Organic fertilization treatment (pacage, 1 sheep m<sup>-2</sup>) has been applied of two times in this experimental period, which it is better than the mineral fertilization because the white clover increased to 26% compared with 7% obtained by mineral fertilization treatment. The pacage and liming combination stimulated the perennial legumes, especially the hybrid trefoil (25%) and white clover (12%). Although yields were increased by the use of mineral fertilizer, taking into account the natural conditions of these grasslands, it is possible that acceptable yields by removing of the nitrogen fertilizers we can apply a biological agriculture.

## Conclusion

The best system for improvement of *Nardus stricta* degraded grasslands in the subalpine zone of Carpathians, is by destruction with herbicides, liming, oversowing and pacage. Liming and oversowing had major effects, even after ten years and gave swards with high pastoral value. Eliminating nitrogen fertilizers makes biological agriculture possible.

## References

- Barbulescu C. and Motca Gh. (1983) Pasunile muntilor inalti, Ed. Ceres Bucuresti.  
 Marusca T. (1977) Sistem de infiintare a pajistilor temporare pe suprafetele dominate de *Nardus stricta* L., Lucrari stiintifice ale SCCP Magurele Brasov, 3, 35-49.  
 Marusca T. and Frame J. (2003) Pasture improvement strategies in the Carpathians pacage with dairy cows, Proceedings of the 12th Symposium of the EGF, Pleven, Bulgaria, 8, 219-221

# Renovation of meadow swards dominated by short grasses by overdrilling

Janicka M.

*The Warsaw Agricultural University (SGGW), Department of Agronomy, Division of Grassland; Nowoursynowska 159; 02-776 Warsaw, Poland*

## Abstract

Many swards are degraded and require regeneration. The objective of the study was the evaluation of yields and the species composition of a meadow sward in the second year after overdrilling in relation to different treatments imposed to limit the competitiveness of the original sward and to the sowing date. The applied renovation technologies increased yields in comparison to that of the original sward. The highest yields and the highest share of species introduced by overdrilling were obtained in the case of overdrilling preceded by either Roundup spraying or rototilling. In central Poland, in a moderately wet habitat, the spring sowing date was more favourable than the late summer date (with the exception of the treatment involving the use of selective herbicides). It was determined that the manner of limiting the competitiveness of the old sward had greater influence on the efficiency of overdrilling than its date. *Dactylis glomerata* was the most useful species for overdrilling, disregarding the technology that was applied. Overdrilling after a previous Roundup spraying was the method that should be used widely for renovation of grasslands in moderately wet habitats.

Keywords: renovation methods, overdrilling, sowing date, yields, species composition

## Introduction

The disappearance of valuable components of a sward, namely tall grasses and papilionaceous plants, is one of the most common symptoms of degradation of meadows and pastures. The sward becomes open, and the volume and quality of yields drops, which calls for renovation of the grassland. The last fifteen years in Poland was a period of intensive research devoted to the oversowing of seeds of grasses and papilionaceous in the old sward using specialist seeders for direct sowing. This method is currently one of the most recommended ways of improving the botanical composition of the sward. The success of overdrilling depends on a number of factors. The most important of these factors are: habitat conditions, selection of species and varieties and overdrilling technology to guarantee sufficient reduction in the vitality of the original sod (Tiley and Frame 1991; Kozłowski 1998; Baryła 2001). The objective of the study was to evaluate the yields and the species composition of a meadow sward in the second year after overdrilling with a mixture of tall grasses and *Trifolium pratense* in relation to different approaches to limit the competitiveness of the old sod and the oversowing date. Moreover, the study determined the usability of the applied overdrilling technologies in the soil and climatic conditions of central Poland.

## Materials and methods

The study was carried out during 2003-2005 at the Experimental Station at Jaktorów (central Poland) in a natural, moderately wet meadow site (water table between 50 and 80 cm) situated on mineral soil (black earth) poor in potassium and with a high phosphorus and magnesium concentration. The experiment was designed as a randomised complete block with four



replications. Each plot was 15 m<sup>2</sup> in area. The experiment was carried out on degraded permanent grassland, which had been extensively managed and fertilised. The meadow had a high proportion of short grasses (about 40%), a very low proportion of valuable tall grass species (less than 10%), a lack of legumes and had been infested with dicotyledonous herbs and weeds (more than 30%). Sward cover density was less than 50%. Competitiveness of the original sward was reduced by: 1) low cutting without herbicides (cutting height: 2-3 cm), 2) herbicides: Starane 250 (11 ha<sup>-1</sup>; active substance: fluroxypyr) + Aminopielik (31 ha<sup>-1</sup>; active substance: 2.4 D), 3) Roundup (51 ha<sup>-1</sup>; active substance: glyphosate) and 4) rototiller. The meadow was renovated over two dates: in spring (21 April 2004) and late summer (27 August 2003). Overdrilling was performed by a Vredo slot seeder. Composition of sown mixture: *Festuca pratensis* cv. Pasja (20%), *Phleum pratense* cv. Kaba (25%), *Dactylis glomerata* cv. Astera (10%) and *Trifolium pratense* cv. Parada (15%) – 24.2 kg ha<sup>-1</sup>. The following doses in kg ha<sup>-1</sup> of mineral fertiliser were applied: 180 N (in three equal doses for each cutting), 30 P (in spring) and 100 K (in two equal doses – in spring and after the first cut). In the second year after overdrilling, three cuts were made. In order to determine the botanical composition of the sward, vegetation samples were taken from each plot before each cut. After carrying out botanical and weight analysis, the percentage share of individual species in the yield of individual regrowths was determined. The yield results were prepared as statistics.

## Results and discussion

In the third decade of August 2003 (late-summer overdrilling), favourable moisture conditions for the initial development of the oversown plants were observed. The beginning of September was relatively dry, yet heavy rains in the third decade of September and at the beginning of October provided young plants with good conditions for development before the winter period. In the spring of 2004, after the spring overdrilling, the weather conditions were also favourable for the initial development of plants. However, in the second half of the vegetation period, a drought took place (in particular in the third decade of August and in the first and second decade of September), which had a negative impact on the development of young plants. Weather conditions during the vegetation period in 2005 were characterised by long periods without rain (Table 1.). High air temperatures combined with low rainfall resulted in the growth period of the first regrowth being very dry whilst it was disastrously dry for the second regrowth (Vinczeffy index – 0.090 and water table was below 100 cm). Greater and more frequent rainfall occurred only in the growth period of the third regrowth, which, according to Vinczeffy (1984), was classified as moderately humid (0.165).

Table 1. Distribution of average daily air temperatures (°C) and monthly rainfalls (mm) in growing seasons 2003-2005

Month	Average daily air temperatures °C			Sums of monthly rainfall mm			Climatic rainfall coefficient $\frac{\sum \text{mm}}{\sum \text{°C}}$		
	2003	2004	2005	2003	2004	2005	2003	2004	2005
IV	6.6	8.9	8.8	32.5	78.7	22.7	0.154	0.293	0.086
V	15.4	11.8	13.3	70.9	38.8	56.6	0.148	0.105	0.135
VI	17.5	15.3	15.8	47.3	69.5	39.6	0.090	0.151	0.084
VII	19.5	17.3	19.7	68.1	55.2	102.4	0.108	0.103	0.168
VIII	17.9	17.5	16.9	45.0	40.8	27.9	0.078	0.075	0.053
IX	13.3	12.4	15.5	39.1	21.2	22.0	0.097	0.057	0.047
IV-IX	15.0	13.9	15.0	302.9	304.2	271.2	0.107	0.119	0.098

Each of the applied renovation technologies resulted in an increase of yields in comparison to the values obtained from the original sward. Slightly higher yields were obtained after renovation was carried out in the spring period. The best method with respect to the increase

of yields, disregarding the date, was the treatment of overdrilling after the application either Roundup spraying or rototilling (Table 2). It is necessary to point out that the total yield obtained in the second year after overdrilling (2005) was significantly lower due to very low yields of the second regrowth. This confirms the opinion that two of the most important factors guaranteeing the success of renovation by means of overdrilling are climatic factors and soil conditions, both in the year of overdrilling and in subsequent years.

Table 2. Yields of dry matter (t ha<sup>-1</sup>) obtained in I-III cuts of the second year after overdrilling due to sowing date and treatment of existing sward

Sward treatment	I cut		II cut		III cut		Total yield**		
	Spring	Late-summer	Spring	Late-summer	Spring	Late-summer	Spring	Late-summer	Mean
Low cutting (without herbicides)	4.52	4.91	1.15	1.15	1.84	1.66	7.51	7.73	7.62ab
Starane + Aminopielik*	4.47	4.10	1.18	1.21	1.61	1.71	7.26	7.03	7.14b
Roundup*	5.43	5.40	1.42	1.40	2.41	2.25	9.26	9.04	9.15a
Rototiller	5.65	5.04	1.68	1.18	2.36	2.06	9.69	8.27	8.98a
Mean	5.02	4.86	1.36	1.24	2.06	1.92	8.43A	8.01A	
Original sward	1.92		0.65		0.69		3.26		

LSD<sub>0.05</sub> for sowing date NS; LSD<sub>0.05</sub> for treatments: 1.59

\* Active substances: Starane – fluroxypyr, Aminopielik – 2,4 D, Roundup - glyphosate

\*\*Figures indicated by the same letters are not significantly different

The applied technologies resulted not only in yield changes, but they also contributed to the change in the species composition of the meadow sward. The species composition was most improved after the application of Roundup and overdrilling, as well as with the use of rototilling and overdrilling. The use of selective herbicides with overdrilling and sole overdrilling had slightly less impact on species composition (Table 3). This confirms the opinion that sufficient damage to the original sward is one of the most important conditions for the success of overdrilling. At the same time, it indicates that rototilling as well as use of Roundup, are the best ways to weaken the original sward and to create adequate conditions for development and growth of the oversown species. The share of oversown grass species was generally slightly higher after spring than late-summer renovation. The exception was treatment with selective herbicides, which gave better results after the late-summer overdrilling. This resulted from the lower regrowth ability of the original sward plants in the second half of the vegetation period and the consequent better development of young plants, which was presented in a previous study (Janicka 2005). The least impact of the sowing date was determined in areas subjected to sward rototilling. Among the oversown species, the main role was played by *Dactylis glomerata*. The significant share of *Dactylis glomerata*, disregarding the applied overdrilling technology, results from the high competitiveness of this species, its nitrophilous aspects and slight sensitivity to harsh habitat conditions. This species develops very well after spring overdrilling. In the second year of use, *Dactylis glomerata* is sufficiently advanced in growth to provide itself with good access to light, water and nutritious components in the soil, and by means of growing long laminae, it dominates the old sward. The usefulness of this species for overdrilling in Poland has been confirmed by numerous experiments (inter alia Grabowski *et al.* 1996; Baryła 2001). Among the remaining species of oversown grasses, both *Phleum pratense* and *Festuca pratensis* had a low share in the yields. The *Phleum pratense* plants are characterised by a slow pace of development, low competitiveness and they are very sensitive to water deficiency. A similar low share of *Festuca pratensis* results from its low competitiveness, especially in more difficult habitat conditions. In the case of all renovation combinations, a decreasing share of *Trifolium pratense* was observed in subsequent regrowths. In the third regrowth mass of 2005, the share

of *Trifolium pratense* in each treatment only amounted to approx. 5%. This phenomenon is highly unfavourable and confirms the low persistence of papilionaceous plants in the sward.

Table 3. Sward botanical composition (%) in I-III cuts of the second year after overdrilling due to sowing date and treatment of existing sward; G – sown grasses, Tp – *Trifolium pratense*, OG – other grasses, D – Herbs and weeds

	Low cutting (without herbicides)								Starane + Aminopielik*							
	Spring				Late-summer				Spring				Late-summer			
	I	II	III	Mean	I	II	III	Mean	I	II	III	Mean	I	II	III	Mean
G	7.3	15.1	21.7	14.7	12.5	22.3	19.5	18.1	5.9	20.7	18.3	15.0	11.0	24.2	28.5	21.2
Tp	9.4	6.4	2.4	6.1	6.9	4.7	1.3	4.3	4.4	8.4	1.3	4.7	7.0	9.5	3.4	6.6
OG	78.1	63.1	56.4	65.8	71.8	56.1	56.2	61.4	86.9	65.1	74.1	75.3	77.1	58.7	60.2	65.4
D	5.2	15.4	19.5	13.4	8.8	16.9	23.0	16.2	2.8	5.8	6.3	5.0	4.9	7.6	7.9	6.8
	Roundup*								Rototiller							
	Spring				Late-summer				Spring				Late-summer			
	I	II	III	Mean	I	II	III	Mean	I	II	III	Mean	I	II	III	Mean
G	33.4	51.8	57.1	47.4	31.4	46.9	45.8	41.4	27.6	39.4	53.9	40.3	20.7	33.2	49.3	34.4
Tp	15.0	13.0	4.2	10.7	12.7	14.4	6.8	11.3	8.4	11.4	5.2	8.3	11.5	6.0	2.2	6.6
OG	41.2	29.9	33.9	35.1	45.5	30.6	40.4	38.8	45.6	36.6	31.7	38.0	55.8	42.2	36.2	44.7
D	10.4	5.3	4.8	6.8	10.4	8.1	7.0	8.5	18.4	12.6	9.2	13.4	12.0	18.6	12.3	14.3

## Conclusions

The applied renovation technologies resulted in an increase of yields in comparison to the yield of the original sward. It was determined that the manner of limiting the competitiveness of the original sward had a greater impact on the overdrilling efficiency than its date. The highest yield and the highest share of species introduced by overdrilling were obtained in the case of overdrilling preceded by either Roundup spraying or rototilling. In central Poland, in a moderately wet habitat, the spring overdrilling was more favourable than the late summer overdrilling, with the exception of overdrilling technology with the use of selective herbicides. *Dactylis glomerata*, in comparison to *Festuca pratensis* and *Phleum pratense*, was the species most suited for overdrilling, disregarding the applied technology. Overdrilling after Roundup spraying is a method for renovating meadows, which should be recommended for wide use.

## Acknowledgements

The study was supported by the Ministry of Science and Higher Education: project No. 3 P06R 108 24.

## References

- Baryła R. (2001) Podsiew jako metoda renowacji runi trawiastej. *Łąkarstwo w Polsce (Grassland Science in Poland)*, 4, 9-24.
- Grabowski K., Grzegorzczak S., Benedycki S. and Marks E. (1996) Przydatność niektórych gatunków traw do podsiewu łąki trwałej. *Zeszyty Problemowe Postępów Nauk Rolniczych*, 442, 89-96.
- Janicka M. (2005) Re-growth of original sward following meadow renovation by the over drilling – central Poland. *Grassland Science in Europe*, 10, 625-629.
- Kozłowski S. (1998) Czynniki warunkujące podsiew użytków zielonych – roślina. *Łąkarstwo w Polsce (Grassland Science in Poland)*, 1, 31-41.
- Tiley G.E.D. and Frame J. (1991) Improvement of upland permanent pastures and lowland swards by surface sowing methods. In: Buchgraber K. *et al.* (eds) *Grassland renovation and weed control in Europe. A Conference of European Grassland Federation held at Graz, Austria* pp. 89-94.
- Vinczeff I. (1984) The effect of some factors on grass yield. In: *Proceedings of the 10<sup>th</sup> General Meeting of European Grassland Federation held at As, Norway* pp. 76-79.

# Yield of a long-term pasture in relation to botanical composition of sward

Daugeliene N. and Butkute R.

*Lithuanian Institute of Agriculture, Vezaiciai Branch, Gargzdu 29, LT-96216,  
Vezaiciai, Klaipėdos District, Lithuania*

## Abstract

In the long-term pasture differing in  $\text{pH}_{\text{KCl}}$  and fertilisation levels, dry matter yield of herbage depended on the combination of botanical composition components and their alternation. On the  $\text{P}_{60}\text{K}_{60}$  background in good moisture conditions, legumes accounted for 44-48 %, whereas in bad moisture conditions legumes accounted for 8 – 11% of the sward area. A strong linear correlation ( $r = 0.778^{**1}$  0.817<sup>\*\*1</sup>) was established between the total herbage dry matter yield and legume dry matter yield in all soil  $\text{pH}_{\text{KCl}}$  levels. The effect of grasses and forbs on the total herbage dry matter yield was higher in the soil with  $\text{pH}_{\text{KCl}}$  6.1-6.5 and 6.6-7.0 levels. On the background of  $\text{N}_{120}\text{P}_{60}\text{K}_{60}$  fertilisation the dry matter yield of herbage did not depend on soil  $\text{pH}_{\text{KCl}}$ . The total dry matter yield of herbage was determined by the yield of grasses. A strong linear correlation ( $r = 0.951^{**1}$  0.964<sup>\*\*1</sup>) was identified between these indicators in all  $\text{pH}_{\text{KCl}}$  levels. A strong linear correlation (0.812<sup>\*\*1</sup> 0.842<sup>\*\*1</sup>) was determined between the total yield and forbs yield in the soil with  $\text{pH}_{\text{KCl}}$  6.1-6.5 and 6.6-7.0 levels.

Keywords: yield, botanical composition, liming, fertilisation

## Introduction

The impact of mineral fertilisers on the floristic composition, productivity and health of long-term pasture at different grazings is very important. Fertilisation affects the floristic diversity of swards already in the first year after application (Koukoura *et al.*, 2005). The yield increases compared to a non-fertilised control were between 47-69 when the sward was grazed and between 64-82 when the sward was cut. The anthropic intervention determined an increase of the weight of species-rich when the doses of fertilizers also increased (Vintu *et al.*, 2006). The representation of legumes in permanent grasslands is markedly affected by a mutual interaction of environmental conditions and the management practices applied to the grassland (Klimeš, 1999; Hopkins and Hrabec, 2001; Pacurar and Rotar, 2004). The availability of N particularly during the first half of the growing season is likely to be the most difficult to estimate. Nevertheless, as it plays a major role in the subsequent development of clover, some means of readily estimating this variable needs to be devised before a reliable decision support system, to predict clover yield and content can, be developed (Laidlaw and Frame, 2006).

## Materials and methods

The soil of the experimental site was a sod podzolic *Hapli-Endohypogleyic Luvisol* (IDg4-p) light loam on medium loam with top soil  $\text{pH}_{\text{KCl}}$  5.2, available  $\text{P}_2\text{O}_5$  of 108 mg  $\text{kg}^{-1}$  and  $\text{K}_2\text{O}$  of 142 mg  $\text{kg}^{-1}$ . Lime was applied before pasture sowing. Limestone rate was calculated according to the titration curves neutralizing the soil with 0.033 N  $\text{CaCl}_2$  solution. Grass mixture, containing 35% *Trifolium repens* L., 40% *Phleum pratense* L. and 25% *Poa pratensis* L. was sown. The sward was fertilised annually in spring with 60 kg  $\text{ha}^{-1}$  of both  $\text{P}_2\text{O}_5$  and  $\text{K}_2\text{O}$ . Nitrogen ( $\text{N}_{120}$ ) fertiliser was split-applied in two times after the 1<sup>st</sup> and 2<sup>nd</sup>

grazing. Treatments were replicated 4 times and grazed 4 times by a herd of dairy cows. The botanical composition (grasses, clovers, forbs) of the samples was measured after separation as dry matter weight. DM yield was determined on the basis of total DM amount per plot and calculated as DM yield ha<sup>-1</sup>. The data of DM yields were statistically analysed by the ANOVA according to Tarakanovas (1999).

## Results and discussion

A very high coefficient of variation suggests that, in different years, the content of legumes was very variable. White clover was the prevalent species (Table 1). The differences between the minimal and maximal content of white clover were very great. This is especially distinct on the N<sub>120</sub>P<sub>60</sub>K<sub>60</sub> fertilisation background since minimal white clover content in the sward did not reach 1% and maximal content varied within 38-45% range. Due to this reason the coefficient of variation exceeded nearly 100% the coefficient of variance calculated from the data obtained on the N<sub>0</sub>P<sub>60</sub>K<sub>60</sub> fertilisation background. Consequently, nitrogen fertiliser, although applied in equal parts after the first and second grazing did not have any appreciable effect on the reduction of competitive power of grasses, and white clover was able to resist their aggression only for the first three years. The variation coefficient of grasses was moderate and differed little between the soil pH levels. With sward senescence its competitive power declined and forbs spread rapidly. Dandelion accounted for the largest share of forbs.

Table 1. The variation of botanical composition in relation to soil pH<sub>KCl</sub> and fertilisation.

Soil pH <sub>KCl</sub>	Average amount %	LSD <sub>05</sub>	Minimum amount %	Maximum amount %	Coefficient of variation V %
<b>Legumes P<sub>60</sub>K<sub>60</sub></b>					
5,1-5,5	25,7	3,19	11	44	43
5,6-6,0	27,0	3,16	8	47	40
6,1-6,5	25,2	3,05	11	44	42
6,6-7,0	26,8	3,39	10	48	44
<b>Legumes N<sub>120</sub>P<sub>60</sub>K<sub>60</sub></b>					
5,1-5,5	8,54	3,63	0,80	42	141
5,6-6,0	7,25	3,44	0,30	38	157
6,1-6,5	10,67	3,80	1,30	45	118
6,6-7,0	8,46	3,52	0,50	40	138
<b>Grasses P<sub>60</sub>K<sub>60</sub></b>					
5,1-5,5	48,0	3,42	26,7	66,4	24
5,6-6,0	46,8	3,40	31,8	64,1	24
6,1-6,5	47,6	2,91	32,0	63,1	20
6,6-7,0	49,7	2,54	35,4	62,5	17
<b>Grasses N<sub>120</sub>P<sub>60</sub>K<sub>60</sub></b>					
5,1-5,5	75,0	3,06	48,1	88,4	14
5,6-6,0	76,6	2,79	54,4	90,3	12
6,1-6,5	73,2	3,17	44,5	83,0	14
6,6-7,0	76,3	2,94	51,8	84,5	13
<b>Forbs P<sub>60</sub>K<sub>60</sub></b>					
5,1-5,5	29,6	3,73	12	46	44
5,5-6,0	30,0	3,89	11	54	45
6,0-6,5	32,1	3,72	16	62	41
6,5-7,0	26,0	2,68	14	50	36
<b>Forbs N<sub>120</sub>P<sub>60</sub>K<sub>60</sub></b>					
5,1-5,5	23,0	1,98	11	38	30
5,5-6,0	23,4	2,79	10	39	41
6,0-6,5	23,8	2,29	11	38	33
6,5-7,0	22,4	1,85	11	32	29

The variation of forbs in pasture sward was very big, however with soil reaction becoming more alkaline, this indicator declined. The least variation in the content of forbs in the pasture sward occurred in the soil with a pH level of 6.5-7.0. The results of correlation analysis showed that on the background of P<sub>60</sub>K<sub>60</sub> fertilisation the dry matter yield of herbage was mostly dependent on the content of legumes in the sward (Table 2). A strong linear correlation was identified between these characteristics in all soil pH levels. The effect of grasses on the total dry matter yield of herbage was more marked in acidulous or close to neutral reaction soil and that of forbs when the soil reaction ranged from pH<sub>KCl</sub> 5.6-6.1 to 6.5-7.0. A strong linear correlation was determined between dry matter yield of herbage and the content of grasses and forbs. On the N<sub>120</sub>P<sub>60</sub>K<sub>60</sub> fertilisation background the total herbage dry matter yield was determined by grasses. A linear correlation of 99% probability level was identified between herbage dry matter yield and yield of grasses in all soil pH<sub>KCl</sub> levels. The content of grasses was determined not only by mineral and lime fertilisers but also by the weather conditions. The yield depended on grasses by 68-80%. Legumes were suppressed by grasses and their content declined having fertilised with nitrogen. With a reduction in the content of legumes the yield of herbage dry matter declined. A strong linear but negative correlation was determined between these indicators only in the soil with a pH<sub>KCl</sub> level of 5.1-5.5. The occurrence of forbs was positively affected by the soil pH<sub>KCl</sub>. With the variation in the soil pH<sub>KCl</sub> from 6.1-6.5 to 6.5-7.0 there was identified a strong linear correlation of 99% probability level between the total dry matter yield of herbage and the yield of forbs.

Table 2. The influence of dry matter yield on yield botanical composition t ha<sup>-1</sup>.

pH <sub>KCl</sub>	Indices		Linear correlation		Linear regression	
	x -grasses	y -yield	r	Sr t <sub>05</sub>	Y	A+ Bx
<b>N<sub>0</sub>P<sub>60</sub>K<sub>60</sub></b>						
5,1-5,5	Grasses	1,39	0.264 n	± 0.322	2,024	0,715
	Legumes	0,93	0.778**1	± 0.210	2,016	1,188
	Forbs	0,70	0.594 n	± 0.268	2,319	0,905
5,6-6,0	Grasses	1,51	0.329 n	± 0.315	1,836	1,011
	Legumes	0,99	0.791**1	± 0.204	2,066	1,312
	Forbs	0,86	0.668*1	± 0.248	2,447	1,069
6,1-6,5	Grasses	1,46	0.619*1	± 0.262	0,261	2,002
	Legumes	0,87	0.786**1	± 0.206	1,911	1,464
	Forbs	0,85	0.72*1	± 0.231	2,042	1,341
6,6-7,0	Grasses	1,52	0.706*1	± 0.236	-0,002	2,081
	Legumes	0,93	0.817**1	± 0.192	1,873	1,376
	Forbs	0,70	0.746**1	± 0.222	1,745	2,005
<b>N<sub>120</sub>P<sub>60</sub>K<sub>60</sub></b>						
5,1-5,5	Grasses	3,68	0.964**1	± 0.088	1,35	0,942
	Legumes	0,40	-0.662*1	± 0.25	5,539	-1,834
	Forbs	0,81	0.68*1	± 0.244	3,078	2,149
5,6-6,0	Grasses	3,74	0.957**1	± 0.097	1,376	0,919
	Legumes	0,28	-0.464 n	± 0.295	5,16	-1,22
	Forbs	0,79	0.547 n	± 0.279	3,52	1,642
6,1-6,5	Grasses	3,48	0.951**1	± 0.103	1,233	0,991
	Legumes	0,41	-0.501 n	± 0.288	5,26	-1,393
	Forbs	0,82	0.812**1	± 0.195	2,499	2,681
6,6-7,0	Grasses	3,69	0.957**1	± 0.097	1,359	0,923
	Legumes	0,34	-0.435 n	± 0.3	5,132	-1,075
	Forbs	0,73	0.842**1	± 0.18	1,907	3,902

\*05 - 95% probability level, \*\*01 - 99 % probability level, 'l' - Linear correlation, 'n' - Non- linear correlation.

## Conclusions

The total herbage dry matter yield of the pasture on the P<sub>60</sub>K<sub>60</sub> fertilisation background in all soil pH<sub>KCl</sub> levels was determined by the yield of legumes ( $r = 0.778^{**} \bar{1} 0.817^{**1}$ ), and on N<sub>120</sub>P<sub>60</sub>K<sub>60</sub> background by the yield of grasses ( $r = 0.951^{**} \bar{1} 0.964^{**1}$ ). The effect of forbs on the total dry matter yield of herbage was more considerable in the soil with pH<sub>KCl</sub> 6.1-6.5 and 6.6-7.0 levels.

## References

- Hopkins A. and Hrabě F. (2001) Organic grassland farming and nature conservation. Organic grassland farming. *Grassland science in Europe*, 6, 91-106.
- Klimeš F. (1999) Phytocenologic relationships in pasture stands. *Plant, Soil and Environment*, 45, 205-211.
- Koukuora Z., Kyriazopoulos A. and Mantzanas K. (2005) Effect of fertilization on floristic diversity and herbage production in a grazed natural rangeland //Integrating efficient grassland farming and biodiversity. *Grassland science in Europe*, 10, 307-310.
- Laidlaw A. S. and Frame J. (2006) Predicting response of perennial reynolds/white clover swards to strategic spring application of nitrogenous fertilizer. *Grassland science in Europe*, 11, 119-121.
- Pacurar F. and Rotar I. (2004) Maintaining biodiversity and increasing the production of dry matter on mountain meadows. Land Use Systems in Grassland Dominated Regions. *Grassland Science in Europe*, 9, 216-218.
- Tarakanovas P. (1999) Statistinių duomenų apdorojimo programų paketas 'Selekcija', Vilnius, 56p.
- Vintu V., Samuil C., Postolache St. and Popovici I. (2006) Influence of fertilization and management on degraded pastures. *Grassland science in Europe*, 10, 86-88.

# Botanical composition and dry matter yield of birdsfoot trefoil swards under simulated grazing

Vasilev E. and Vasileva V.

*Institute of Forage Crops, 89 Gen. Vl. Vazov Str., 5800 Pleven, Bulgaria*

## Abstract

A field trial under non-irrigated conditions on low leached chernozem soil was carried out at the Institute of Forage Crops, Pleven during the period of 2004-2006. Birdsfoot trefoil ("Targovishte 1" variety) was studied in a pure stand, as well as in binary mixtures with cocksfoot ("Dabrava" variety) and with wheatgrass (*Agropyron cristatum* L.). The sowing rate of the legume: grass mixtures was 1:1. The swards were cut at the height of 20-25 cm to imitate grazing regime of utilization. It was found that birdsfoot trefoil portion was greater in swards of the mixtures with wheatgrass, as compared to the mixture with cocksfoot. The weed infestation in the mixture of birdsfoot trefoil with cocksfoot was considerably lower, as compared to the pure birdsfoot trefoil. Dry matter yield obtained from the mixtures of birdsfoot trefoil with cocksfoot was higher than the yield obtained from the pure birdsfoot trefoil for the second year and similar for the third year.

Keywords: birdsfoot trefoil, dry matter, botanical composition, mixture

## Introduction

Birdsfoot trefoil is a pasture species with high nutritive value, non-bloating characteristics and ability to withstand close grazing (Abberton *et al.*, 2005; Hopkins and Holz, 2006). It is a suitable component for perennial herbaceous mixtures, which are more resistant and often perform better than pure swards (Leep *et al.*, 2002; Mannetje, 2006). The objective of this study was to determine botanical composition and dry matter yield of birdsfoot trefoil swards under pasture regime of utilization.

## Materials and methods

During the period 2004-2006 a field trial was carried out without irrigation by the long plot method with five variants, four replications and a plot size of 10 m<sup>2</sup>. Soil subtype is slightly leached chernozem. Birdsfoot trefoil ("Targovishte 1" variety) was studied in a pure stand, as well as in binary mixtures with cocksfoot ("Dabrava" variety), and with wheatgrass (*Agropyron cristatum* L. - local population). Before basic cultivation 300 kg ha<sup>-1</sup> P<sub>2</sub>O<sub>5</sub> and 150 kg ha<sup>-1</sup> K<sub>2</sub>O were applied, depending on soil supply. Nitrogen (50 kg ha<sup>-1</sup>) was applied at the time of sowing (first decade of April). Chemical weed control was not conducted. The sowing rate was 15 kg ha<sup>-1</sup> for birdsfoot trefoil and 25 kg ha<sup>-1</sup> for cocksfoot and wheatgrass. The legume:grass ratio was 1:1 in the sown mixtures. The swards were cut at the height of 20-25 cm to imitate grazing regime of utilization. Three, five and four cuts were obtained in 2004, 2005 and 2006, respectively. A botanical analysis of harvested herbage was conducted following each cut. Data of dry matter were submitted to analyses of variance and means were compared to those obtained from pure birdsfoot trefoil stands using LSD.



## Results and discussion

In the year of establishment, birdsfoot trefoil predominated in all swards in which it participated (Figure 1). The grass portion was low in the mixtures and did not correspond to the sowing ratio. When sown in spring these perennial grass species don't form reproductive stems in the year of establishment. Weed infestation of pure grasses and mixtures was greater than that of the pure birdsfoot trefoil. Grasses were practically absent in the sward of the mixtures and their portion was smaller than that of the weeds in their pure stands in the drier and hot months during formation of second cut. During the second year, the botanical composition of the swards significantly differed from that in the establish year. That was due to reproductive development of grasses, as well as to interrelations between birdsfoot trefoil on the one hand and grasses on the other hand, on the background of natural weed infestation.

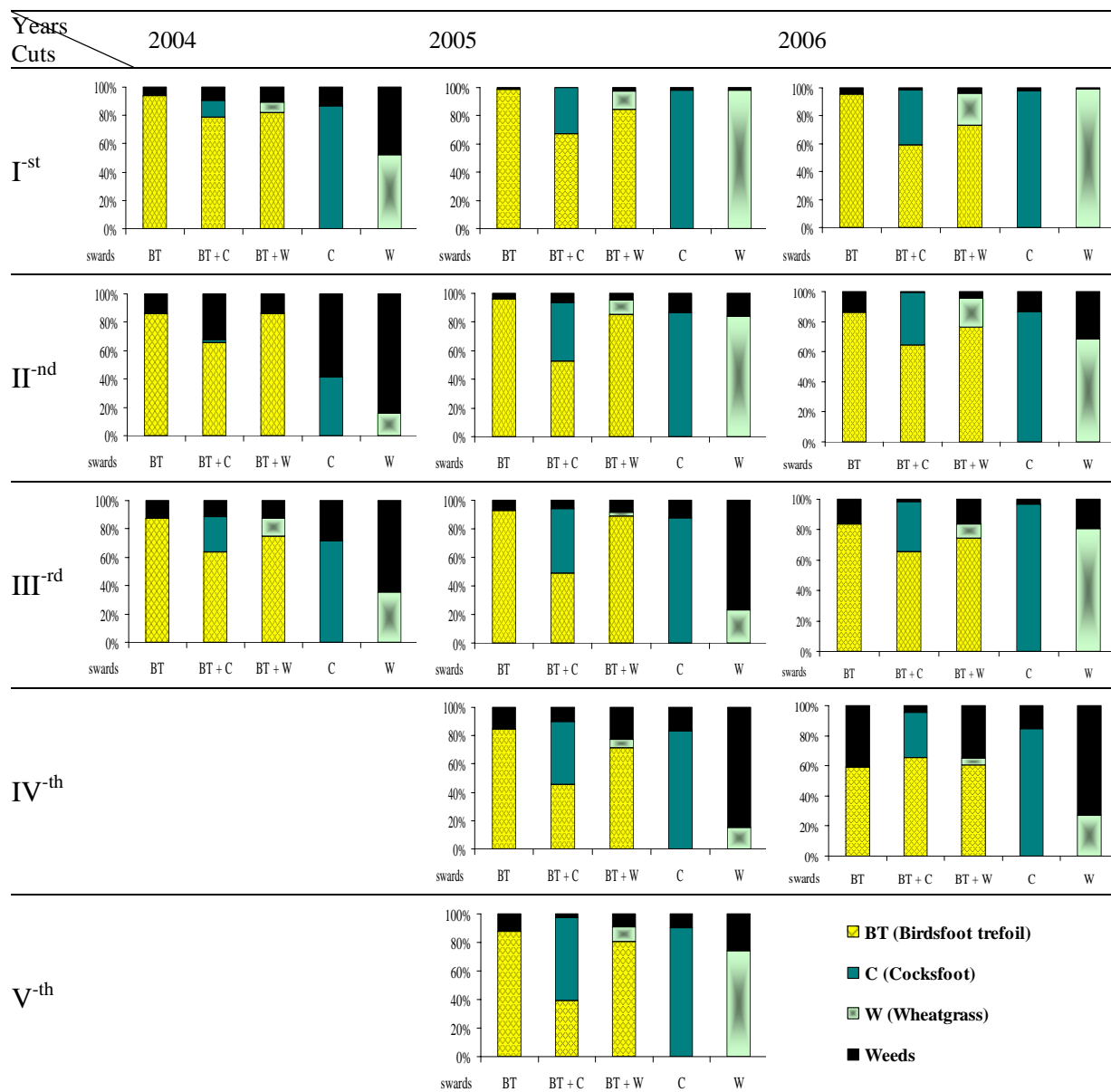

Figure 1. Botanical composition of the swards

The birdsfoot trefoil predominated in all cuts of wheatgrass mixture, as well in the first and second cut of cocksfoot mixture. In the third cut birdsfoot trefoil and cocksfoot had approximately equal portion, but in the four and fifth cut cocksfoot predominated. The weed

portion in birdsfoot trefoil swards was the lowest in mixture with cocksfoot. There were no significant differences between weed infestation in pure birdsfoot trefoil and that in wheatgrass mixture.

During the third year the birdsfoot trefoil predominated in all cuts of its swards. Its portion in the wheatgrass mixture was higher than that in cocksfoot mixture in the first second and third cut. The portion of cocksfoot was bigger than that of wheatgrass in mixtures.

The weed infestation in the sward of pure birdsfoot trefoil was bigger than that in wheatgrass mixture in the first and second cut, but in the third and fourth cut it was similar. The cocksfoot mixture practically was without weed infestation in the first three cuts and less infested in the fourth. The weed portion in the pure wheatgrass sward was several times higher than that in pure cocksfoot in the second, third and fourth cuts.

After the year of establishment only the dry mass yield of cocksfoot mixture significantly exceeded that obtained from the pure birdsfoot trefoil in second and third cuts and as a total for the second (2005) year. The wheatgrass mixture was more dry mass productive in the fourth cut than pure birdsfoot trefoil, but the weed portion in that cut was significant (Fig. 1). During the third year the yields of dry mass in the first cut of both mixtures exceeded that obtained from the pure birdsfoot trefoil. The dry mass yields of cocksfoot mixture in the third cut, as well as in fourth cut for both mixtures were lower than those of birdsfoot trefoil. However, we have to notice the significant weed portions in the mentioned cuts of the pure birdsfoot trefoil, as well as for its mixture with wheatgrass.

Table 1. Dry matter yield (kg ha<sup>-1</sup>) of the swards

Treatments	Cuts					Total	%
	I	II	III	IV	V		
2004							
1. BT 100%	4416	1008	991	-	-	6416	100.0
2. BT 50% + C 50%	4685	1031	1602	-	-	7318	114.1
3. BT 50% + W 50%	2698	1119	1485	-	-	5302	82.6
4. C 100%	2164	884	1051	-	-	4100	63.9
5. W 100%	802	1265	1455	-	-	3521	54.9
2005							
1. BT 100%	2324	4552	2557	2154	1416	13003	100.0
2. BT 50% + C 50%	2342	5457	3015	2177	1663	14655	112.7
3. BT 50% + W 50%	2375	4661	2663	2402	1473	13574	104.4
4. C 100%	2339	3318	1566	1065	1513	9800	75.4
5. W 100%	1777	2335	609	740	926	6387	49.1
LSD 5%	274	348	236	139	316	962	
2006							
1. BT 100%	1911	1963	1451	1448	-	6773	100.0
2. BT 50% + C 50%	2560	1724	1108	1210	-	6602	97.5
3. BT 50% + W 50%	2634	1779	1361	1275	-	7049	104.1
4. C 100%	943	862	427	437	-	2669	39.4
5. W 100%	526	729	359	420	-	2034	30.0
LSD 5%	202	247	169	247		704	

BT, Birdsfoot trefoil; C, Cocksfoot; W, Wheatgrass

## Conclusions

Birdsfoot trefoil portion was greater in swards of the mixtures with wheatgrass, as compared to the mixture with cocksfoot. The weed infestation in the mixture of birdsfoot trefoil with cocksfoot was considerably lower, as compared to the pure birdsfoot trefoil. Dry matter yield obtained from the mixtures of birdsfoot trefoil with cocksfoot was higher than the yield obtained from the pure birdsfoot trefoil for the second year and similar for the third year.

## References

- Abberton M.T., Fothergill M., Collins R.P., Michaelson-Yeates T.P.T., Williams T.A., Marshall A.H. and Olyott P. (2005) Breeding forage legumes for enhanced biodiversity. In: Wachendorf M., Helgadottir A. and Parente G. (eds.). Sward dynamics, N-flows and Forage Utilisation in Legume-Based Systems. *Proceedings of the 2<sup>nd</sup> COST 852 workshop*, Nov. 10-12, 2005, Grado, Italy, ISBN: 88-89402-05-9, 21-24.
- Hopkins A. and Holz B. (2006) Grassland for agriculture and nature conservation: production, quality and multi-functionality. *Agronomy Research*, 4 (1), 3-20.
- Leep R., Jeranyama P., Min D., Dietz T., Bughrara S. and Isleib J. (2002) Grazing Effects on Herbage Mass and Composition in Grass-Birdsfoot Trefoil Mixtures. *Agronomy Journal*, 94, 1257-1262.
- 't Mannetje L. (2006) Climate change and grassland through the ages- an overview. In: Lloveras J., Gonzales-Rodríguez A., Vazquez-Yañez O., Piñeiro J., Santamaría O., Olea L. and Poblaciones M. J. (eds.). Sustainable Grassland Productivity. *Proceedings of the 21<sup>st</sup> General Meeting of the European Grassland Federation, Grassland Science in Europe*, April 3-6, 2006, Badajoz, Spain, vol. 11, 733-738.

# The floristic biodiversity of the main hill and mountain pasture types from the S-W of Romania and their productive capacity

Ionescu I. and Osiceanu M.

*The University of Craiova, the Faculty of Agronomy, Romania*

## Abstract

Studies were carried out on two meadows of types prevalent in S-W Romania. An *Agrostis capillaris* meadow, situated at 300 m altitude, was made up of 39 species (10 graminaceous, 7 leguminous and 22 species of other botanical families), most of them hemicryptophytes, indifferent to temperature, humidity and the reaction of the soil. A *Nardus stricta* meadow, situated at 1600 m altitude, was composed of 34 species, of which 7 graminaceous, 2 leguminous, 2 cyperaceous and 23 plants of other botanical families. Most species were hemicryptophytes, specific to the chill-temperate areas, preferring damp to humid soils, adaptable or preferential to acid soils. The production, of both types of meadows was markedly increased with manure administrated in different doses, together with low doses of NPK.

Keywords: permanent meadows, biodiversity, organic fertilizers

## Introduction

In S-W Romania, the different climatic and edaphic conditions give rise to great floral diversity in the permanent meadows. In the Sub-Carpathian area, *Agrostis capillaris* meadows are common whilst in the mountain area *Nardus stricta* meadows are prevalent. Both types of meadows have low production, and this is also demonstrated by the pastoral value (determined through the geobotanical method) which is of 2.53 for the hill meadow and of only 0.58 for the mountain meadow, compared to the maximum value of 5 at the highly productive meadows.

## Materials and methods

During 4 years of trials (2003-2006) studies were made on an *Agrostis capillaris* hill meadow, located in the Sub-Carpathian Depression of Oltenia, at 300 m altitude, and on a *Nardus stricta* meadow, located at 1600 m altitude in the Parang Mountains.

A range of fertilizer treatments involving organic manures and low doses of chemical fertilizers were applied as shown in Table 2. The experiments were laid out in the hay fields and consisted of random blocks with 4 replicates. Assessments were made of floristic composition, soil conditions and productivity.

## Results and discussion

### *The floristic biodiversity.*

The *Agrostis capillaris* meadow was made up of 39 species, comprising 10 graminaceous, 7 leguminous and 22 species of other botanical families. *Agrostis capillaris* had the highest level of cover (35%), followed by *Festuca rubra* (23%).

The meadow is dominated by hemicryptophytes, which have a cover of 94%, represented by 28 species with important contributions from: *Agrostis capillaris*, *Festuca rubra*,

*Anthoxanthum odoratum*, *Poa pratensis*, *Lotus corniculatus*, *Trifolium pratense*, *Trifolium repens*. The rest of the bioforms have an insignificant cover (Table 1).

Table 1. The specific biodiversity of the permanent hill and mountain meadows

Biodiversity elements	The <i>A. capillaris</i> meadow		The <i>N. stricta</i> meadow		
	Number of species	Cover %	Number of species	Cover %	
The bioform	Hemicriptophyta	28	94	23	87
	Terophyta- hemiterophyta	3	2	-	-
	Hemicriptophyta- geophyta	1	+	-	-
	Hemiterophyta	2	+	-	-
	Terophyta	3	1	1	+
	Hemiterophyta- Hemicriptophyta	1	1	1	+
	Hemicriptophyta- Chamaephyta	1	+	-	-
	Chamaephyta	-	-	5	7
	Geophyta	-	-	2	+
	Mezophanerophyta	-	-	1	+
	Nanophanerophyta- Chamaephyta	-	-	1	4
	Temperature index	Indifferences	21	81	16
Cold- chill areas		-	-	3	5
Chill areas		-	-	8	6
Chill- temperate areas		-	-	7	12
Temperate areas		6	11	-	-
Temperate- warm areas		6	4	-	-
Warm areas		6	4	-	-
The reaction of the soil	Indifferences	23	82	13	27
	Very acid soils	-	-	1	1
	Very acid- acid soils	-	-	7	57
	Acid soils	1	1	6	5
	Acid – acid moderate soils	2	1	5	8
	Acid moderate soils	3	6	2	2
	Moderate acid- neuter soils	1	1	-	-
	Neuter soils	4	7	-	-
Neuter – basic soils	5	2	-	-	

The analysis of the value of the temperature index shows that 21 species that cover 81 % of the meadow surface are temperature indifferent: *Agrostis capillaris*, *Festuca rubra*, *Poa annua*, *Lotus corniculatus*, *Achillea millefolium*, *Hieracium pilosella*, etc. 18 species are specific to the temperate, warm temperate or warm areas. Concerning the soil reaction, indifferent species are clearly dominant, both as number (23) and as coverage (32%). Species preferring moderate acid soils are also presented (*Anthoxanthum odoratum*, *Potentilla argentea*, *Veronica serpyllifolia*) as are those preferring neutral soils (*Trifolium patens*, *Galium verrum*, *Potentilla reptans*).

The *Nardus stricta* meadow had 34 species, of which 7 were graminaceous, 2 ciperaceous, 2 leguminous and 23 species of other botanical families. Of the graminaceous species, *Nardus stricta* had 45% cover, while the others had smaller cover (*Agrostis capillaris* 15%, *Deschampsia flexuosa* 5%, *Anthoxanthum odoratum* 2%, *Festuca ovina ssp. sudetica* 1%). The leguminous species (*Trifolium pratense*, *Trifolium repens*), were rarely found, and of the diverse species *Hieracium aurantiacum* covered 5 % and the *Vaccinium sp.* 4 %. Hemicriptophytes also dominated this meadow (23%), covering a total of 87% of the meadow surface.

Plants had low temperature indexes, being representative of the mountain climate, for example: *Deschampsia flexuosa*, *Alchemilla vulgaris*, *Campanula abietina*, specific to the chill-temperate areas, *Crocus heuffelianus*, *Hieracium aurantiacum*, *Soldanella montana*,

*Festuca ovina ssp. sudetica*, *Potentilla ternata* or *Geum montanum*, specific to the cooler areas.

Most species are adaptable or prefer acid or very acid – acid soils: *Nardus stricta*, *Deschampsia caespitosa*, *Vaccinium vitis idaea*, *Geum montanum* etc.

*The productivity.*

The hill meadow of the *Agrostis capillaris* type has currently low dry matter (DM) productivity, of 1.4 -2 t/ha, because of the lack of care and improvement works. With organic fertilizers or combinations of organic and mineral fertilizers, the production increased on average for 4 years to 3.21-5.02 t DM/ha. (table 2).

Table 2. The influence of organic fertilizers, alone or together with chemical fertilizers, on the production of hill and mountain meadows (2003-2006 average)

Variants	The <i>A. capillaris</i> meadow			The <i>N. stricta</i> meadow		
	t DM/ha	Difference	Significance	t DM/ha	Difference	Significance
10 t annually	3.40	+0.15	-	1.85	-0.02	-
20 t at 2 years	3.21	-0.04	-	1.78	-0.09	-
40 t at 4 years	3.25	-	Reference crop	1.87	-	Reference crop
10 t annually + 50 N,50 P, 50 K annually	4.77	+1.52	**	3.10	+1.23	***
20 t at 2 years + 50 N,50 P, 50 K annually	4.71	+1.46	**	2.53	+0.66	*
40 t at 4 years + 50 N,50 P, 50 K annually	5.02	+1.77	***	2.61	+0.74	**
20 t at 2 years + 50 N, 50 P, 50 K <sup>1)</sup>	4.33	+1.08	*	2.38	+0.51	*
40 t at 4 years + 100 N, 50 P, 50 K <sup>2)</sup>	4.72	+1.47	**	2.39	+0.52	*
DL 5 %		0.90			0.51	
DL 1 %		1.24			0.68	
DL 0.1 %		1.61			0.92	

1) Fertilizers minerals only in the year without manure

2) Chemical fertilizers only in years 3 and 4(without manure)

If differences:  $\geq 0.1\%$  very significant \*\*\* ;  $\geq 1\%$  distinct significant \*\* ;  $\geq 5\%$  significant \* ;

$\leq 5\%$  non significant -

The organic fertilizer, applied alone, had a lower productivity, meaning a little over 3 t DM/ha, depending on the dose and the application spell. For the combined treatments, the yields were higher, especially at the yearly treatments using chemical fertilizers. The trial with 40 t/ha manure every 4 years and 50 N 50 P<sub>2</sub>O<sub>5</sub> 50 K<sub>2</sub>O applied yearly had an yield of 5.02 t DM/ha, with a very significant positive difference of 1.77 t/ha compared to the trial with 40 t/ha manure every 4 years considered as reference.

The *Nardus stricta* meadow, much more deteriorated, with current productions of 1-1.2 t DM/ha. increased production up to 3.10 t DM/ha. at the treatment with 10 t/ha manure + 50 kg N, 50 kg P<sub>2</sub>O<sub>5</sub> , 50 kg K<sub>2</sub>O annually applied. The other variants, with manure doses of 20-40 t/ha periodically applied, together with chemical fertilizers, have made 2-2.5 t DM/ha and the treatments with manure alone, only 1.78 – 1.87 t/ha DM.

The meadow's botanical composition was modified under the influence of the fertilizers (less at the treatments with manure only and more at the combined treatments):

-For the *Agrostis capillaris* meadow the percentage of graminaceous (*Agrostis capillaris*, *Festuca rubra*, *Arrhenatherum elatius*, *Lolium perenne*) increased from 50% to over 70%, the percentage of leguminous increased from 7% to 13-15% and the percentage of plants from other botanical families decreased;

-For the *Nardus stricta* meadow, the dominant species decreased from around 60% to 40%, increasing the percentage of *Festuca rubra*. On this meadow, there was no registered increase of the leguminous percentage, no matter what treatment used.

## Conclusions

The main types of hill and mountain meadows in S-W Romania are of the *Agrostis capillaris* type and the *Nardus stricta* type. In the *Agrostis capillaris* meadow there were 39 species (10 graminaceous, 7 leguminous, 22 others), most of them hemicryptophytes, indifferent to the thermal factor, as well as to the reaction of the soil. The mountain meadow, *Nardus stricta*, had 34 species (7 graminaceous, 2 leguminous, 2 ciperaceous and 23 others) most of them hemicryptophytes specific to the chill areas, with a preference for acid soils. The production of these meadows was improved in treatments with: 10 t/ha manure + 50 N, 50 P<sub>2</sub>O<sub>5</sub>, 50 K<sub>2</sub>O annually (the *Nardus stricta* meadow) or with 20-40 t/ha manure applied every 2-4 years, together with 50-100 N, 50 P<sub>2</sub>O<sub>5</sub>, 50 K<sub>2</sub>O in the non-fertilized years (the *Agrostis capillaris* meadow).

## References

- Cardasol V. (1994) Fertilisation organique de prairies permanents roumaines ; synthese de resultats d ' essais multilocaux et de longue duree. Fourrages, 139.
- Ionescu I. and Osiceanu M. (2004) Cercetari privind imbunatatirea pajistilor permanente de munte prin fertilizare organica. Lucr.st. vol. 47, Iasi.
- Ionescu I., s.a. (2001) Pajistile permanente din nordul Olteniei. Edit. Universitaria, Craiova.
- Pavel C., s.a. (1973) Pajistile din zona subcarpatica a Olteniei. Edit. Scrisul Romanesc, Craiova.

# Dynamic of changes in botanical composition of meadow sward in conditions of differentiated fertilisation and optimal moisture

Barszczewski J., Wolicka M. and Burs W.

*Institute for Land Reclamation and Grassland Farming at Falenty, Al. Hrabaska 3, 05-090 Raszyn, Poland*

## Abstract

The study on mineral soil was conducted in two stages: 1988-1993 (a new reseeded meadow) and 1995-2000 (resowing of this parcel with the same mixture of species as in 1988). Fertilisation treatments with nitrogen (N) and sulphur (S) were different in level and type of used fertilisers: A (N-120 kg ha<sup>-1</sup>), B (N-240 kg ha<sup>-1</sup>), C (N- 360 kg ha<sup>-1</sup>), D (NS-240 kg ha<sup>-1</sup>), E (NS-360 kg ha<sup>-1</sup>). With the increase in N fertilisation the P and K fertilisation increased too. On NS objects all K doses and part of N and P doses were covered by the use of slurry. After 6 years of study a dominance of *Dactylis glomerata* and *Agropyron repens* was stated on B, C, D and E treatments as well as an excess of *Taraxacum officinale* on all the treatments. In 1994 the meadow was resown because of an inappropriate botanical composition. In 2000, the sixth year after renovation, similar changes were stated in the botanical composition of the sward as in 1993.

Keywords: meadow sward, changes of botanical composition, fertilisation, renovation

## Introduction

Soil moisture and fertilisation are important factors for yield and botanical composition of a meadow sward. The changes in botanical composition in optimal moisture conditions depend on form and quantity of fertilisation and frequency of meadow cutting. Some of the studies show that grassland fertilisation with slurry (Michna 1982, Nowak 1984) can be the reason of its weeding by the increase of *Taraxacum officinale* Webb. Maćkowiak, Mazur (1987) and Jargiełło and Sawicki (1982) show that slurry application increases the participation in the sward of *Dactylis glomerata* L., *Phleum pratense* L., *Poa pratensis* L., *Agropyron respens* L. or *Bromus inermis* Leyss.

The aim of study was to evaluate the changes of botanical composition of meadow sward during a 6 year-period.

## Material and methods

The experiment was established in Falenty on degraded black soil. Its granulometrical composition was: middle clay to 80 cm and deeper loose sand or weakly loamy sand. Before the start of the experiment (spring 1987) the parcel was ploughed and limed (dose 2.0 t ha<sup>-1</sup> CaO). The grass mixture contained 10% *Alipcurus pratensis*, 20% *Festuca pratensis*, 15%, *Phelum pratense*, 10% *Dactylus glomerata*, 10% *Agrostis gigantea*, 10%, *Poa pratensis*, 20% *Lolium perenne* and 5% *Triforium hybridum* L.. The experiment with random block design was established in four replicates. In the first three years the grass was cut tree times per season, later on it was cut four times.

The botanical composition in the first cut in 1994 showed an excess of some inferior grass species and large weeds. This botanical composition showed the necessity of meadow renovation. Renovation was made by harrowing 4 times and sowing the same grass mixture.



In the following year the botanical composition of the sward in the first cut was very similar to 1988. For this reason four botanical analysis on particular blocks were done and the results were averaged for every treatment.

On the A, B, C objects (Table 1) only chemical fertilisers were used: ammonium nitrate (34.5% N), tripled super phosphate (20.1% P) and potash salt (47.3% K). On the D and E treatments liquid cattle manure fulfilled the potassium need; phosphorus and nitrogen were completed respectively by super phosphate and ammonium nitrate. The liquid manure was always analysed. The average content was 3 g N kg<sup>-1</sup>, 0.2 g P<sub>2</sub>O<sub>5</sub> kg<sup>-1</sup>, 5.4 g K<sub>2</sub>O kg<sup>-1</sup> and 40 g dry matter kg<sup>-1</sup>. Liquid manure was used in equal doses in every cut. The phosphorus demand was fulfilled once in spring. In the period of study the DM yield was evaluated. In the first and sixth year of the study the botanical-gravimetric analysis was used to evaluate changes of the botanical composition.

Table 1. Fertilisation in the experiment in Falenty

treatment	dose, kg ha <sup>-1</sup>					
	years 1988 - 1990			after year 1991		
	N	P	K	N	P	K
A	120	35	83	120	35	100
B	240	52	124	240	52	150
C	360	70	166	360	70	299
D	240	52	124	240	52	149
E	240	52	124	360	70	299

## Results an discussion

In the first year of study (1988) on all the plots the prevailing species were: *Lolium pratense* L. (37.0%) *Dactylis glomerata* L. (20.2%) and *Festuca pratensis* L. (19.7%). There was an amount of *Phleum pratense* L. (16.8%) but *Poa pratensis* L. and *Festuca rubra* had a minor participation in the meadow sward: 1.6% and 2,3% respectively. A small participation of *Agropyron repens* L., *Poa trivialis* L. and *Bromus inermis* Leyss. was noticed on some plots. Among legumes only *Trifolium pratense* L. was stated on several plots. *Taraxacum officinale* Webb (0,6%) was the most important herb.

In 1993, the sixth year, the significant increase of *Dactylis glomerata* L. on all the objects was noticed but the largest increase was situated on the treatments fertilized with liquid manure. On the D and E treatment the *Dactylis glomerata* L. participation was 45% and 65% respectively. A considerable decrease of *Phleum pratense* L., *Lolium perenne* and *Festuca pratensis* L. was noticed on all objects fertilised with mineral and organic-mineral forms of fertilisers. Large increase of participation of *Poa pratensis* L. was noticed on all mineral fertilised objects and the largest increase was on treatment A (25.7%). Treatment C had the highest participation of *Agropyron repens* L. (51,5%). Other grass species showed no important changes. In this stage of study a total disappearance of legumes in the meadow sward was observed. In the group of herbs and weeds a very significant growth of *Taraxacum officinale* Webb. was stated on all the treatments but especially on the organic–mineral fertilised treatments.

The six-year period of utilisation of the resown meadow caused large weeding with many species. The participation of weeds on the different treatments was 15% to 35%, and proved the necessity of meadow renovation.

In the year after renovation, the grasses participated in the botanical composition for 97.8%. The participation of legumes was only 1% and the group of herbs and weeds was 1.2% (Table 2). The dominant grass species were *Lolium perenne* L. (16.0%), *Festuca pratensis* L. (17.8%), *Dactylis glomerata* L. (17.3%) and *Phleum pratense* L. (1.0%). The following six-year period was characterized by high yields (Figure 1): about 6 t ha<sup>-1</sup> of hay on treatment A

to about 11 t ha<sup>-1</sup> of hay on C and E and caused significant changes in botanical composition of the meadow sward.

Table 2. The participation of the individual species in the meadow sward

Species	1988 - average from all treatments	1993					1995 - average from all treatments	2000				
		A	B	C	D	E		A	B	C	D	E
<i>Dactylis glomerata</i>	20.2	37.9	40.6	28.8	45.2	62.8	17.3	40.8	23.1	17.0	58.0	64.1
<i>Phleum pratense</i>	16.8	3.1	7.0	1.7	4.7	0.7	16.0	2.2	2.0	0.8	1.5	1.0
<i>Lolium perenne</i>	37.0	2.7	0.6	0.1	2.0	1.9	24.1	3.3	0.9	0.3	6.0	2.3
<i>Poa pratensis</i> L.	1.6	25.7	19.9	11.0	9.2	4.5	5.6	34.4	61.0	51.8	18.4	9.4
<i>Festuca pratensis</i> Huds.	19.7	2.4	2.6	0.7	1.6	2.7	17.8	3.1	0.4	0.3	3.0	0.4
<i>Festuca arudinacea</i> Scherb.							0.5	0.2	0.1		0.1	0.1
<i>Festuca rubra</i> L.	2.3	0.2					0.8	9.3	1.5	0.7	5.0	0.6
<i>Agropyron repens</i> L.	0.8	5.5	7.7	41.5	2.5	3.1	0.3	0.9	8.9	28.2	2.8	16.9
<i>Agrostis gigantea</i> L.	0.1	0.1	0.1	0.8	0.1		5.6				0.5	
<i>Bromus inermis</i> Leyss.	0.2	0.1	0.6			0.1						
<i>Bromus mollis</i> L.		0.2										
<i>Poa annua</i> L.	0.3	0.5		0.1		0.1						
<i>Poa trivialis</i> L.	0.3	0.6	0.1		0.1	0.1	0.5	0.1			0.4	0.1
<i>Arrhenthurum elatius</i> L.									0.2			
<i>Alopecurus pratensis</i> L.							9.3					
<i>Lolium multiflorum</i> Lam.								1.8	0.3	0.1	0.7	0.4
<i>Holcus lanatus</i> L.												
Total grasses	99.0	79.0	79.2	84.7	65.4	76.0	97.8	96.1	98.4	99.2	96.4	95.3
Total legumes	0.1						1.0					
<i>Taraxacum officinale</i> Webb.	0.6	20.0	19.8	14.6	34.2	23.6	0.8	2.9	0.3		3.0	2.4
<i>Cerastium vulgatum</i> L.							0.3	0.3	0.1			
<i>Stellaria media</i> L.	0.1	0.1	0.6	0.3	0.2	0.2	0.1	0.1				
<i>Sinapsis arvensis</i> L.		0.6	0.1	0.3		0.1						
<i>Capsella bursa-pastoris</i>		0.2	0.2	0.1	0.1							
<i>Cirsium arvense</i> Webb.		0.1	0.1		0.1	0.1		0.3		0.8	0.3	
<i>Achillea millefolium</i> L.	0.3										0.2	
<i>Rumex obtusifolius</i> L.								0.3	1.2		0.1	2.3
Total weeds and herbs	0.9	21.0	20.8	15.3	34.6	24.0	1.2	3.9	1.6	0.8	3.6	4.7
Total	100.0	100.0	100.0	100.0	100.0	100.0	100.0	100.0	100.0	100.0	100.0	100.0

In 2000, after a six-year period of meadow utilisation, a significant increase of participation of *Dactylis glomerata* L. was stated on the majority of the treatments. On treatment B this increase was comparatively small and on treatment C there was no increase at all. On treatment A, D and E *Dactylis glomerata* L. was dominant with a participation between 40.8% and 64.1%. A significant decrease of *Phleum pratense* L. (to 2%), *Lolium perenne* L. (from 0.9% to 6.0%) and *Festuca pratensis* L. (from 0.3% to 3.0%) was stated on all the treatments, similarly to the previous stage of this study. On all the treatments *Poa pratensis* L. increased. The minor increase of *Poa pratensis* L. occurred on both treatments with liquid manure and completed with mineral fertilisers (D and E). On some treatments, especially C and E, a significant increase of *Agropyron repens* L. was stated, but this was less than in the first study period. In this stage of study the significant increase of participation of *Festuca rubra* L. on all the treatments was stated, especially on treatment A. The participation of other grasses was insignificant (from 0.1% to 2%). The total participation of grasses was very considerable, from 95.3% to 99.2%, and the highest level was found on the C treatment. In 2000, similar to 1993, there were no legumes at all. On all the plots in 2000 a insignificant increase of herbs and weeds (from 0.8% to 4.7%) was observed in the meadow sward in comparison with 1993.

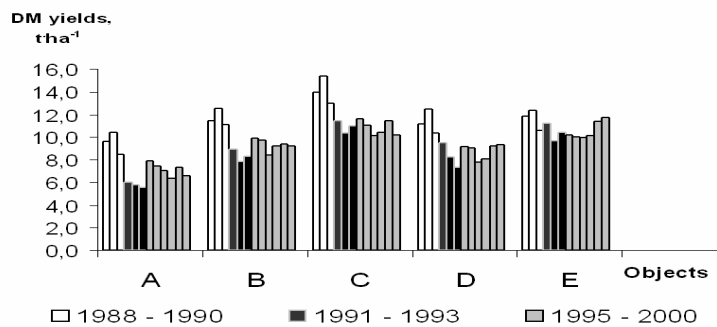

Fig. 1 Annual DM yields of a meadow sward on the experiment in Falenty

The study confirms the results of other authors (Maćkowiak and Mazur 1978; Jargiełło and Sawicki 1982) about the increase *Dactylis glomerata* L., *Poa pratensis* L and *Agropyron repens* L on treatments with liquid manure fertilisation. The study do not confirm the increase of *Phleum pratense* L. and *Bromus inermis* Leyss caused by this form of fertilisation. The first stage of this study shows the significant increase of *Taraxacum officinale* Webb. on all the treatments, and especially on the treatments with liquid manure, which confirms the results Michna (1982) and Nowak (1984). Progressive changes in the second stage of the study do not confirm results of those authors. A significant increase of *Poa pratensis* L. in both stages, especially on treatments with mineral fertilisation, indicate the influence of mineral fertilisation on the increase of *Poa pratensis* L. in the meadow.

## Conclusions

Optimal soil moisture in combination with a small fertilisation rate created good conditions for the development of *Dactylis glomerata* L. and *Poa pratensis* L. in a meadow sward.

A positive reaction of *Agropyron repens* L. in high levels of mineral fertilisation resulted in an important participation of this species in the meadow.

The study proved also a positive influence of liquid manure on development of *Dactylis glomerata* L. in the meadow sward.

Dynamic development of weeds, mostly *Taraxacum officinale* Webb., in the first stage of the study was caused by scattered sod. In the second stage, after resowing, there was no increase of weeds because renovation resulted in a more dense sod.

## References

- Jargiełło J. and Sawicki B. (1982) Wpływ nawożenia gnojowicą i składu mieszanek na plonowanie kwaterowego pastwiska w Końskowoli. W: Dotychczasowe osiągnięcia nauki w zakresie gospodarki pastwiskowej. Mater. Semin. Nr 17. Falenty; IMUZ s. 171 – 178.
- Mazur T. and Maćkowiak Cz. (1978) Nawożenia gnojowicą. Wpływ gnojowicy na właściwości fizyczne i biologiczne gleb. Warszawa: PWRiL ss. 112.
- Michna G. (1982) Efektywność wysokiego nawożenia gnojowicą bydłą trwałych użytków zielonych w warunkach podgórskich. W: Dotychczasowe osiągnięcia nauki w zakresie gospodarki pastwiskowej. Mater. Semin. nr 17. Falenty; IMUZ s. 163-170.
- Nowak M. (1984) Gnojowica jest dobrym nawozem. Plon nr 40/41 z. 78 s. 11.

# The changes of sward botanical and chemical composition depending on pasture improvement measures

Butkuvienė E. and Butkutė R.

*Vėžaičiai Branch of Lithuanian Institute of Agriculture (LIA), Gargždų 29, LT-5845  
Vėžaičiai, Klaipėdos district, Lithuania*

## Abstract

The influence of different pasture improvement measures (herbicide application, fertilisation, oversowing, resowing) on sward botanical and chemical composition was investigated during 2000-2004. Three trials were carried out on different by proportion of forbs and DM yield old pastures. All measures used for sward improvement changed pasture botanical and chemical composition and significantly increased pasture yield. Spraying by herbicide decreased the amount of forbs in the sward by 1.9-10.5% and insignificantly (0.3-2.3%) decreased the amount of legumes. Fertilising with 120 kg N ha<sup>-1</sup> considerably decreased the amount of forbs by 6.8-7.9% and the amount of legumes, however, pasture DM yield was the highest. Additional oversowing increased amount of legumes in the sward by 9.1-10.5% and decreased the amount of forbs by 2.4-4.7%. The sward was enriched with legumes by 6.4-8.2% and the amount of forbs decreased by 0.8-9.4% after pasture resowing. N fertilisation, additional oversowing and resowing increased accumulation of crude proteins in pasture sward. The accumulation of crude fibre in the pasture sward was less using additional oversowing and resowing. No considerable changes in crude ash and crude fat amounts depending on different improvement measures were determined.

Keywords: botanical composition, resowing, oversowing, fertilization, chemical composition

## Introduction

Investigations carried out in different locations in Lithuania with the aim to improve pastures suggest that it is not necessary to resow pastures with 60-70% of good grasses. It is possible to improve them by surface treatments (Zimkus, 1992; Butkuvienė and Zableckienė, 1997). The renovation of degraded pastures in south-west Poland with two methods of sward renovation, namely herbicide use in combination with direct drilling and full tillage, proved to be suitable (Wolski and Stypinski, 2001). The renovation of permanent grasslands by overdrilling results in the incorporation of valuable grass and legume species and leads to the improvement of herbage quality and yield (Komárek and Kohoutek, 1998; Goliński and Kozłowski, 2000). Some researchers have noted that pasture productivity usually needs to be maintained by mineral fertiliser application, especially application of nitrogen. Nitrogen fertilisers N<sub>120</sub>-N<sub>240</sub> in limed pasture, independently from phosphorus and potassium fertiliser rates, increased pasture's productivity by 2.19 - 3.38 t ha<sup>-1</sup> and improved forage quality (Daugėlienė, 2002). The efficiency of nitrogen fertilisers was less in pastures, arranged on acid soils. Therefore, fertilisation with 120 kg N ha<sup>-1</sup> and with 240 kg N ha<sup>-1</sup> increased pasture DM yields by 1.72 and 1.91 t ha<sup>-1</sup> respectively (Butkuvienė and Butkutė, 2005). Zimkus (1995) claims, that increased N fertiliser rate from 60 to 180 kg N ha<sup>-1</sup> results in grass DM yield increase by 37-97%. Oversowing and resowing increased pasture DM yields from 25% to 40% and 75% respectively. The highest amount of legumes was determined in oversown and resown pastures. Increased N fertiliser rates lead to the gradual increase of grass yield and crude protein content.

## Materials and methods

Different improvement measures were investigated on pasture of 15-18 years old pastures where grasses were dominant. White clover (*Trifolium repens* L.) accounted for 10-20% and forbs for 25-35% (mainly dandelion, *Taraxacum officinale* L., yarrow, *Achillea millefolium* L. and buttercup, *Ranunculus repens* L.). The research was carried on *Haplic-Albic Luvisols* with topsoil pH<sub>KCl</sub> 5.2-6.2; 60-184 mg P<sub>2</sub>O<sub>5</sub> kg<sup>-1</sup>; 104-122 mg K<sub>2</sub>O kg<sup>-1</sup> and 2.9-3.7% humus. Research was carried out on different pastures: i) sprayed with herbicide MCPA (3.7 l ha<sup>-1</sup>) in autumn, at the beginning of the research and ii) not sprayed with herbicide. On both pastures, 4 treatments were compared: i) control, without any improvement measure; ii) fertilisation with 120 kg N ha<sup>-1</sup>; iii) oversowing with a white clover and timothy (*Phleum pratense* L.) mixture and iv) resowing. The legume-grass mixture: white clover cv. 'Atoliai' (4 kg ha<sup>-1</sup>) and timothy cv. 'Gintaras II' (2 kg ha<sup>-1</sup>) was oversown with a disk drill straight in the pasture sward. The mixture, which contained white clover cv. 'Atoliai' 25%, timothy cv. 'Gintaras II' 40%, smooth-stalked meadow grass (*Poa pratensis* L.) cv. 'Danga' 25% and meadow fescue (*Festuca pratensis* Huds.) cv. 'Dotnuvos I' 10% was used for resowing. The mixture was sown with a cover crop – spring barley (*Hordeum vulgare* L.) cv. 'Roland' for grain. Each treatment had four replications and was fertilised annually with 60 kg P<sub>2</sub>O<sub>5</sub> ha<sup>-1</sup> and 60 kg K<sub>2</sub>O ha<sup>-1</sup> in spring. Nitrogen fertilisers (120 kg ha<sup>-1</sup>) were applied in two times: after 1<sup>st</sup> and 2<sup>nd</sup> grazing.

## Results and discussion

Three year average data of three experiments are presented in the paper. As indicated in table 1, grasses accounted the highest proportion in sward botanical composition.

Table 1. Improvement measures influence on pasture sward botanical composition.

Measure of improvement	Plant group	Non-sprayed background				Sprayed background			
		1 <sup>st</sup> trial	2 <sup>nd</sup> trial	3 <sup>rd</sup> trial	mean	1 <sup>st</sup> trial	2 <sup>nd</sup> trial	3 <sup>rd</sup> trial	mean
Control	grasses	54,4	50,7	53,4	52,8	64,9	69,4	56,4	63,6
	legumes	20,4	16,0	18,8	18,4	17,3	17,3	19,8	18,1
	forbs	25,2	33,3	27,8	28,8	17,8	13,3	23,8	18,3
Fertilisation N <sub>120</sub>	grasses	73,0	76,9	76,0	75,4	89,3	89,5	82,5	87,1
	legumes	5,0	2,4	3,9	3,7	0,7	1,4	2,1	1,4
	forbs	22,0	20,7	20,1	20,9	10,0	9,1	15,4	11,5
Oversowing	grasses	48,4	48,8	43,9	47,0	63,1	63,7	43,9	56,9
	legumes	27,4	23,9	35,3	28,9	20,9	24,8	35,9	27,2
	forbs	24,2	27,3	20,8	24,1	16,0	11,5	20,2	15,9
Resowing	grasses	54,8	57,8	54,9	55,8	52,4	61,2	54,8	56,2
	legumes	22,8	21,6	29,9	24,8	24,6	23,4	31,0	26,3
	forbs	22,4	20,6	15,2	19,4	23,0	15,4	14,2	17,5
LSD <sub>05</sub>		grasses 4.59; legumes 5.75; forbs 5.45				grasses 9.41; legumes 6.59; forbs 7.46			

Spraying herbicide decreased the proportion of forbs in the pasture sward in all three trials. Consequently, the amount of grasses increased. However, the considerable increase by 9.9-11.7% was determined only in old pasture (control). The proportion of grasses was similar both in sprayed and non-sprayed with MCPA resown pasture. According to the average data, spraying by herbicide considerably decreased the amount of forbs in the sward by 1.1-1.8 times or 1.9-10.5% and insignificantly decreased the amount of legumes by 0.3-2.3%. Legumes suffered from spraying.

Fertilising with 120 kg N ha<sup>-1</sup> considerably increased the amount of grasses by 22.6-23.5% and decreased the amount of forbs by 6.8-7.9%. Applied nitrogen fertilisers significantly decreased the amount of legumes by 14.7-16.7% and legumes nearly died out. Therefore,

grasses spread out. Despite unfavourable meteorological conditions for permanent grass seeds germination (1<sup>st</sup> and 2<sup>nd</sup> trial), the amount of legumes after pasture oversowing increased. Oversown mixture seeds germinated rather well in 3<sup>rd</sup> trial and plants persisted during considered period. The average data of three experiments showed, that oversowing with legume-grass mixture increased amount of legumes in the sward by 9.1-10.5%. The amount of forbs was insignificantly less in oversown swards.

Pasture resowing had effect on all considered trials. As a result, pasture botanical composition improved and productivity increased. The sward was enriched with legumes by 6.4-8.2% after pasture resowing. After non-sprayed pasture was resown the amount of forbs significantly decreased by 9.4%. Sward weedness insufficiently decreased by 0.8 % after pasture resowing, sprayed with MCPA.

Table 2 summarises the data on the changes of sward chemical composition depending on used different pasture improvement measures. Additional oversowing and resowing resulted in increase of legumes in the pasture sward, what influenced positively the accumulation of crude protein. The same tendency in pastures, fertilised with nitrogen, was observed. The average data showed that considerable increase of crude protein amount in non-sprayed pasture sward was obtained only when oversowing was done. However, all measures had no considerable influence on crude protein amount, when the pasture was sprayed with herbicide.

Table 2. Improvement measures effect on pasture sward chemical composition.

Measure of improvement	Non-sprayed background				Sprayed background			
	1 <sup>st</sup> trial	2 <sup>nd</sup> trial	3 <sup>rd</sup> trial	mean	1 <sup>st</sup> trial	2 <sup>nd</sup> trial	3 <sup>rd</sup> trial	mean
Crude protein g kg <sup>-1</sup> DM								
Control	151	136	148	145	150	130	144	141
Fertilisation N <sub>120</sub>	154	153	149	152	151	145	147	148
Oversowing	168	161	153	161	147	158	150	152
Resowing	154	139	160	151	149	146	163	153
LSD <sub>05</sub>	20.3	23.2	10.0	14.2	18.6	15.5	16.3	15.8
Crude fibre g kg <sup>-1</sup> DM								
Control	215	226	230	224	216	251	227	231
Fertilisation N <sub>120</sub>	230	228	248	235	240	252	251	248
Oversowing	215	220	219	218	229	234	220	228
Resowing	212	235	224	224	213	233	225	224
LSD <sub>05</sub>	11.4	22.2	18.2	14.5	21.8	11.9	21.8	15.6
Crude fat % in DM								
Control	4.64	4.94	4.64	4.74	4.41	4.13	4.54	4.36
Fertilisation N <sub>120</sub>	4.94	4.86	4.48	4.76	4.16	4.20	4.54	4.30
Oversowing	4.50	4.93	4.50	4.64	4.23	4.12	4.60	4.32
Resowing	4.25	4.35	4.74	4.45	4.24	4.52	4.44	4.40
LSD <sub>05</sub>	0.720	0.808	0.358	0.481	0.604	0.669	0.660	0.300
Crude ash % in DM								
Control	8.35	9.49	8.86	8.90	8.13	9.28	9.21	8.87
Fertilisation N <sub>120</sub>	7.76	8.51	7.82	8.03	7.39	8.91	8.64	8.31
Oversowing	8.82	9.40	8.92	9.05	8.31	9.04	8.88	8.74
Resowing	9.42	8.74	8.20	8.79	8.41	9.09	8.50	8.67
LSD <sub>05</sub>	1.015	1.084	0.889	0.890	1.012	1.305	0.960	0.567

The crude fibre content in the sward changed slightly after improving the non-sprayed pasture by considered measures. According average data the increase of the crude fibre content was significant only when the pasture was sprayed with MCPA and fertilised with nitrogen. The accumulation of crude fibre in the pasture sward was inconsiderably less using additional oversowing and resowing measures. No considerable changes in crude ash and crude fat content depending on different improvement measures were determined.

According to the average data, different improvement measures significantly increased pastures yield (Table 3). The highest yield increase by 1.68-1.75 t ha<sup>-1</sup> was obtained with nitrogen fertilisation in both sprayed and non-sprayed pastures. Pasture resowing also significantly increased dry matter yield by 1.45-1.56 t ha<sup>-1</sup>. Oversewing significantly increased pasture dry matter yield by 0.97-1.09 t ha<sup>-1</sup>. The significantly higher amounts of metabolisable energy were obtained when improving pasture by fertilisation with 120 kg N ha<sup>-1</sup> and resowing with legume-grass mixture in both sprayed and non-sprayed pastures. The highest metabolisable energy yield (57.7-57.8 GJ ha<sup>-1</sup>) was obtained in the treatments where nitrogen fertilisers were applied.

Table 3. The influence of pasture improvement measures on sward productivity.

Measure of improvement	Non-sprayed background				Sprayed background			
	1 <sup>st</sup> trial	2 <sup>nd</sup> trial	3 <sup>rd</sup> trial	mean	1 <sup>st</sup> trial	2 <sup>nd</sup> trial	3 <sup>rd</sup> trial	mean
DM yield t ha <sup>-1</sup>								
Control	4.36	4.08	2.54	3.66	4.23	4.31	2.80	3.78
Fertilisation N <sub>120</sub>	6.00	5.98	4.25	5.41	5.72	6.04	4.63	5.46
Oversowing	4.95	5.13	3.82	4.63	4.96	5.60	4.06	4.87
Resowing	5.64	5.74	3.94	5.11	5.67	6.16	4.20	5.34
LSD <sub>05</sub>	0.18	0.14	0.24	0.11	0.19	0.21	0.26	0.12
Metabolisable energy GJ ha <sup>-1</sup>								
Control	43.0	39.6	32.3	38.3	41.3	40.6	31.7	37.9
Fertilisation N <sub>120</sub>	62.0	61.2	50.3	57.8	60.2	59.9	53.0	57.7
Oversowing	49.7	49.3	44.4	47.8	46.3	51.3	43.4	47.0
Resowing	65.3	62.2	39.9	55.8	64.6	65.9	41.3	57.3
LSD <sub>05</sub>	17.68	15.44	12.64	9.48	19.85	18.24	11.07	10.15

## Conclusions

Additional oversowing and resowing improved the feeding value of the sward, as the amount of legumes increased and amount of forbs decreased. Spraying with herbicide (MCPA, 3.7 l ha<sup>-1</sup>) decreased the proportion of forbs in the sward by 1.1-1.8 times.

Fertilisation with nitrogen, additional oversowing and resowing had no considerable influence on the chemical composition of pasture. However, considered measures tended to increase the amount of crude protein in pasture sward.

Effect of all considered measures on pasture DM yield arranged in the rank of priority: fertilisation with 120 kg N ha<sup>-1</sup>, resowing and additional oversowing.

## References

- Butkuvienė E. and Zableckienė D. (1997) Improvement of pastures by additional sowing seed of white clover. *Agriculture: Works of Lithuanian Institute of Agriculture*, 59, 170-178.
- Butkuvienė E. and Butkutė R. (2005) Fertilization – the effective measure of pastures improvement. *Grassland Science in Europe*, 10, 617 - 620.
- Daugelienė N. (2002) *Grassland management on acid soils*, Arx-Baltica, Kaunas, 261 pp.
- Goliński P. and Kozłowski S. (2000) Role of grassland overdrilling in the increase of feed economical efficiency and protection of meadow soil. *Grassland Science in Europe*, 5, 191-193.
- Komárek P. and Kohoutek A. (1998) The influence of non-tilling slot seeding of legumes and grasses into grassland on the improvement of nutritional quality of feed. *Grassland Science in Europe*, 3, 765-768.
- Wolski K. and Stypinski P. (2001) The use of white clover in seed mixtures of sward renovation of degraded pastures on private farms in South-West Poland. *Grassland Science in Europe*, 6, 86-89.
- Zimkus Z. (1992) Oversewing of white clover into sprayed with herbicide pasture. *Works of Lithuanian Institute of Agriculture*, 69, 31-37.
- Zimkus Z. (1995) The effectiveness of three nitrogen fertilization rates for white clover in cereal grass. *Agriculture: Works of Lithuanian Institute of Agriculture*, 46, 56-61.

# Changes in biomass in relation to shrub cover in semi-arid Mediterranean rangelands

C. C. Karakosta and V. P. Papanastasis

*Laboratory of Rangeland Ecology, Faculty of Forestry and Natural Environment, Aristotle University of Thessaloniki, P.O. Box 286, GR - 54124, Thessaloniki, Greece*

## Abstract

The assessment of changes in herbage and woody biomass in relation to shrub cover is critical for planning sustainable management of Mediterranean rangelands. The aim of this study was to evaluate shrub cover effects on dry matter yield during secondary succession following extensification of human activities, especially fuelwood collection and goat grazing. The study was conducted in Lagadas county, northern Greece, in June 2005. In four types of vegetation, namely abandoned field grassland, open and dense shrublands located in a gradient of increased land use extensification, the aboveground herbage and woody biomass were measured. In addition shrub and total plant cover as well as diameter, mean and maximum height of the dominant shrub species were also measured. It was found that shrub cover increased as extensification increased resulting in a reduction of herbaceous cover. Current year's, old and total herbage biomass decreased as shrub cover increased, but the same components of the woody and total (herbage and woody) biomass were increased. A strong parabolic correlation between production and shrub cover was found. On the contrary, the correlation between biomass of the two dominant woody species and their height and diameter was not strong suggesting that further research is needed to find out non-destructive methods of estimating biomass of woody species in Mediterranean rangelands.

Keywords: biomass, shrub cover, secondary succession, Mediterranean rangelands

## Introduction

The majority of Mediterranean rangelands have been derived from natural forests after removal of tree cover by human activities such as clearing, wildfires and overgrazing. If these activities are altered or become less intensive then natural succession is initiated which leads to the invasion of woody plants. In Greece, where the majority of grasslands are communally-grazed successional plant communities, any reduction of human intervention leads to a series of land use changes and eventually to woodlands (Papanastasis 2004). Such a development results in species composition changes (Papadimitriou *et al.* 2004) as well as in reduction of herbage and available forage production (Platis and Papanastasis 2003, Zarovali *et al.* 2004) but it is not known how total forage production is affected. The aim of this study was to investigate how shrub cover affects above-ground biomass and its components in Mediterranean rangelands.

## Materials and methods

The research was conducted in Lagadas county, northern Greece (40° 47' N, 23° 12' E), in June 2005. The study area amounts to 575 ha and is located at an altitude of about 500m. a.s.l. In a gradient of increased distance from a near by village reflecting a gradual extensification of human activities, mainly involving farming, goat grazing and fuelwood collection, four types of vegetation characterised by different amounts of shrub cover, namely an abandoned



arable field for at least 10 years, a grassland, open and dense shrublands, were identified. In each type, four 30 x 30 m plots (replications) were established. Herbage and woody biomass were harvested at the end of the growing season. Measurements were done in 16 quadrats of 1 m<sup>2</sup> in size within each type. Herbaceous and woody species were cut at the ground level. Maximum and mean heights and crown diameter at breast height of shrubs were also measured. Finally, shrub and total plant cover was ocularly estimated. In the laboratory, herbage and woody biomass was sorted out by hand into current year's and old growth components. All biomass was oven dried at 60° C for 48 h and weighed. Data were subjected to analysis of variance; if significant, the Duncan's multiple range test was applied. Regression analysis was used to determine the best linear and quadratic models fitted between production and shrub cover or allometric characters (maximum height, mean height and crown diameter) of the dominant shrubs.

## Results and discussion

Total plant cover (%) was found to be 80.25±19.23, 80.34± 6.26, 76.09±14.24 and 82.42±17.31 respectively for abandoned field, grassland, open and dense shrublands, indicating no substantial differences among the four types of vegetation. On the contrary, shrub cover differed substantially with 0, 6.09±4.28, 36.41±5.29, 60.47±6.40 respectively for the abandoned field, grassland, open and dense shrublands, suggesting four distinct shrub cover types. It is obvious therefore that with increase in shrub cover there was a corresponding reduction of herbaceous cover. Sibbald *et al.* (1991) reports that changes in woody cover significantly affects the cover of herbaceous species.

Current year's, old and total herbage biomass gradually decreased as shrub cover increased (Table 1). More specifically, current year's growth was significantly reduced from the abandoned field to grassland (by 21%) as well as from the grassland to open shrubland (by 50%), while the reduction from the open to dense shrubland (by 42%) was not significant. Old growth and total herbage biomass were significantly different only between the first two and the last two shrub cover classes.

Table 1. Herbage biomass (g DM m<sup>-2</sup>) in the four shrub cover classes.

Biomass class	Shrub cover (%)			
	0	6	36	60
Current year's	263.5a <sup>1</sup>	208.1b	103.4c	60.4c
Old	149.5ab	196.5a	101.1bc	38.6c
Total	413.0a	404.6a	204.5b	99.0c

<sup>1</sup>Means within the same class followed by the same letter are not statistically different at the 0.05 level.

As expected, woody biomass was substantially increased as shrub cover increased in the last three types that contained shrubs (Table 2). Specifically, current year's growth significantly increased from the grassland to the open shrubland (by 811%), while the increase from the open to dense shrubland (by 24%) was not significant. Similar but more impressive increases occurred in the other two woody biomass components (old and total). Total biomass (herbage and woody) was dominated by the woody component in the last two shrub cover classes and resulted in significant differences similar to the ones of the woody biomass alone (Table 3). Specifically, current year's growth significantly increased from the grassland to both shrubland types, while the other two components (old and total) also significantly increased from the open to dense shrubland.

Table 2. Woody biomass (g DM m<sup>-2</sup>) in the four shrub cover classes.

Biomass class	Shrub cover (%)		
	6	36	60
Current year's	76.3 b <sup>1</sup>	694.8a	860.3a
Old	587.1c	2000.9b	7451.3a
Total	663.4 c	2695.7b	8311.6a

<sup>1</sup>Means within the same class followed by the same letter are not statistically different at the 0.05 level.

Table 3. Total biomass (g DM m<sup>-2</sup>) in the four shrub cover classes.

Biomass class	Shrub cover (%)		
	6	36	60
Current year's	292.3b <sup>1</sup>	798.2a	920.8a
Old	844.4c	2101.9b	7489.9a
Total	1136.7c	2900.1b	8410.6a

<sup>1</sup>Means within the same class followed by the same letter are not statistically different at the 0.05 level.

Table 4 shows the relation between herbage and woody biomass with shrub cover. It is clear that although both linear and quadratic models produced strong correlations, the latter models resulted in higher coefficients of determination than the former ones indicating that the growth of herbage and woody biomass in relation to shrub cover is better expressed by a parabola than by a line. This means that production capacity of extensified rangelands may be reduced if shrub cover increases too much (Platis and Papanastasis, 2003).

Table 4. Relation between biomass parameters and shrub cover in the four shrub cover classes.

Biomass parameter(g DM m <sup>-2</sup> )	Equation	R <sup>2</sup>
Current year's herbage (H <sub>c</sub> )	H <sub>c</sub> = -2.549X* + 210.8	0.790***
	H <sub>c</sub> = 0.036X <sup>2</sup> -4.972X+228.2	0.818***
Total herbage (H <sub>t</sub> )	H <sub>t</sub> = -5.489X+426.4	0.816***
	H <sub>t</sub> = 0.090X <sup>2</sup> -11.48X+469.7	0.847***
Current year's woody (W <sub>c</sub> )	W <sub>c</sub> = 13.85X+68.30	0.767***
	W <sub>c</sub> = -0.396X <sup>2</sup> +39.70X-132.0	0.880**
Total woody (W <sub>t</sub> )	W <sub>t</sub> = 132.6X-661.4	0.828***
	W <sub>t</sub> = 1.650X <sup>2</sup> +38.77X+275.1	0.896***

\*\*\*: P<0.001, \*\*:P<0.01 \*X : shrub cover (%)

Table 5 shows the relation between current and total biomass of the shrubs *Quercus coccifera* and *Q. pubescens* with easily measured allometric parameters such as maximum height, mean height and crown diameter of the particular shrubs. It is clear the correlations produced for linear and quadratic models are not strong although some coefficients of determination are statistically significant. These results show that the allometric parameters used are not good enough to predict biomass of shrubs and that further research is needed to find out a better way of determining shrub biomass without having to employ costly destructive methods.

Table 5. Relation between biomass and allometric parameters of the shrubs *Quercus coccifera* and *Q. pubescens*.

Species	Biomass (Y) (g DM m <sup>-2</sup> )	Height (H) or crown diameter (D) (m)	Equation	R <sup>2</sup>	
<i>Q. coccifera</i>	Current	H <sub>max</sub>	Y= 303.2H <sub>max</sub> + 125.0 Y=-55.85H <sub>max</sub> <sup>2</sup> +580.0H <sub>max</sub> -165.9	0.106 0.111	
		H <sub>mean</sub>	Y=361.5H <sub>mean</sub> +311.2 Y=-159.7H <sub>mean</sub> <sup>2</sup> +910.4H <sub>max</sub> -73.77	0.088 0.104	
		D	Y=-1102D +973.9 Y=-26,007D <sup>2</sup> +7917.9D+606.8	0.006 0.030	
	Total	H <sub>max</sub>	Y=3129.9H <sub>max</sub> -3329.2 Y=734.5H <sub>max</sub> <sup>2</sup> -509.4H <sub>max</sub> +495.6	0.392*** 0.421***	
		H <sub>mean</sub>	Y=4309.3H <sub>mean</sub> -2352.3 Y=992.3H <sub>mean</sub> <sup>2</sup> +899.1H <sub>mean</sub> +39.98	0.431*** 0.453***	
		D	Y=-2303.7D+4854.3 Y=-377,204D <sup>2</sup> +128,518D-469.9	0.001 0.174	
	<i>Q. pubescens</i>	Current	H <sub>max</sub>	Y=218.0H <sub>max</sub> -70.73 Y=13.5 H <sub>max</sub> <sup>2</sup> +89.71H <sub>max</sub> +200.6	0.138 0.139
			H <sub>mean</sub>	Y=433.4H <sub>mean</sub> -205.8 Y=282.2H <sub>mean</sub> <sup>2</sup> -1036.7H <sub>mean</sub> +1449.1	0.213* 0.267
			D	Y=6306.4D+274.1 Y=-5576.6D <sup>2</sup> +7813.1D+192.0	0.162 0.163
Total		H <sub>max</sub>	Y=4479.7H <sub>max</sub> -12,047 Y=676.6H <sub>max</sub> <sup>2</sup> -1909.8 H <sub>max</sub> +1470.2	0.222* 0.231	
		H <sub>mean</sub>	Y=9221.4H <sub>mean</sub> -15,704 Y=7187.7H <sub>mean</sub> <sup>2</sup> -28,228H <sub>mean</sub> +26,456	0.367** 0.499**	
		D	Y=42,584D+5162.4 Y=-2E+06D <sup>2</sup> +509,012D-20,260	0.028 0.191	

\*\*\*: P<0.001, \*\*: P<0.01, \*: P<0.05

## Conclusion

Increased shrub cover as a result of extensification of management activities in semi-arid Mediterranean rangelands leads to increased woody biomass but decreased herbage yields.

## Acknowledgements

The senior author acknowledges the Greek State Scholarships' Foundation (IKY) for the financial help in this research as a part of the European Research Project 'VISTA'.

## References

- Papadimitriou M., Tsougrakis Y., Ispikoudis I. and Papanastasis V.P. (2004) Plant functional types in relation to land use changes in a semi-arid Mediterranean environment. Proceedings 10<sup>th</sup> MEDECOS Conference, April 25 - May 1 2004, Rhodes Greece, (Arianoutsou and Papanastasis, eds). Millpress
- Papanastasis V.P. (2004) Vegetation degradation and land cover changes in agrosilvopastoral systems. In: Schnabel S. and Ferreira A. (eds) Advances in GeoEcology, 37, 1-12.
- Platis P.D. and Papanastasis V.P. (2003) Relationship between shrub cover and available forage in Mediterranean shrublands, *Agroforestry Systems*, 57, 59-67.
- Sibbald A.R., Griffiths J.H. and Elston D.A. (1991) The effects of the presence of widely spaced conifers on under-story herbage production in the U.K. *Forest Ecology and Management*, 45, 71-77
- Zarovali M. P., Tsougrakis Y. and Papanastasis V. P. (2004) Herbage production in relation to land use changes in Mediterranean rangelands. *Grassland Science In Europe*, 9, 201-203. 20th General Meeting of European Grassland Federation, 'Land use systems in grassland dominated regions'. Luzern, Switzerland, 21-24 June 2004.

# Sward structure of meadows under different cutting and mulching managements

Gaisler J. and Pavlů V.

*Crop Research Institute, Department of Plant Ecology and Weed Science, CZ-460 01 Liberec, Czech Republic*

## Abstract

Sward structure and biomass accumulation were studied on an upland meadow in the Jizerské Mountains in 2000-2006. Five methods of grassland management (unmanaged control, two cuts of herbage biomass per year, mulched once, twice, or three times per year) were established on a meadow dominated by *Festuca rubra*. Botanical composition was recorded every year at the end of May. The total aboveground (yield, stubble, litter and/or mulch) and belowground plant biomass was sampled every year in October. The number of plant species was higher and legumes (mainly *Trifolium repens*) were spread in the meadows managed on more than one occasion per year. The lowest total aboveground biomass was recorded in the twice cut meadow whereas the highest aboveground biomass was in the unmanaged control meadow. However, there was an opposite response for belowground biomass. Mulching two times per growing season could be used as an alternative management practice for landscape maintenance of upland grassland areas without agricultural utilization.

Keywords: grassland, botanical composition, biomass, cutting, mulching

## Introduction

In the last decade of the 20<sup>th</sup> century a reduction in the number of cattle graziers decreased the importance of semi-natural grasslands for forage production in Europe. As a consequence many of the grasslands in mountain and upland areas were abandoned. If left to run wild these abandoned species-rich grasslands may change into species-poor degraded phases of tall herbs or grasses that are able to compete effectively for light and nutrients (Laser 2002, Pecháčková and Krahulec 1995). In many cases, unmanaged extensive meadows and pastures are invaded by shrubs and trees and are eventually altered into woodlands by natural progression. Consequently the biodiversity is often reduced and some rare or protected plant species disappear. The aim of our study was to reveal suitable alternative management practices to traditional cutting in grassland areas without agricultural utilization.

## Materials and methods

The study started in 1997 at an experimental area in the Jizerské hory Mountains, 420 m above sea level, with an average annual temperature of 7.2°C, annual precipitation of 803 mm and soil cambisol acid - pH 4.7. The following management treatments were applied to a meadow dominated by *Festuca rubra* L.:

- U: unmanaged control
- 2C: two cuts of herbage biomass per year (June, August)
- 1M: mulched once per year (July)
- 2M: mulched twice per year (June, August)
- 3M: mulched three times per year (May, July, September)

Each treatment plot of 3.5 m x 10 m was replicated four times. Mulching was made by the machine Uni maher UM 19, which crushes and breaks down plant biomass into an even layer on the surface of the sward. The percentage cover of all plant species growing in the plots was visually estimated. To reduce any edge effects of the plots a rectangular sampling area of 8.0 m x 2.5 m was estimated in the centre of each plot. Relevés recording was performed annually in May before the first application of the management regimes. Nomenclature followed Kubát *et al.* (2002). To study the plant biomass accumulation (in dry matter, DM) in the meadows the aboveground and belowground biomass were sampled randomly at the end of the growing season in 2000, 2002, 2004 and 2006. Aboveground plant biomass was estimated by cutting and weighing herbage from four replicate areas of 0.1 m<sup>2</sup> in each plot, and was sampled in two layers of 0-3 cm and >3 cm. Belowground plant biomass was estimated from four replicate soil cores with a diameter of 5 cm taken in each plot.

## Results and discussion

The number of plant species was higher in all of the meadows where cutting or mulching was applied two or three times per year compared to the unmanaged and once mulched meadows (Figure 1). The appropriate frequency of disturbance is one of the key factors for coexistence of a high number of plant species as is generally known in a number of studies (e.g. Bakker 1989, Ryser *et al.* 1995, Santrucek *et al.* 2002).

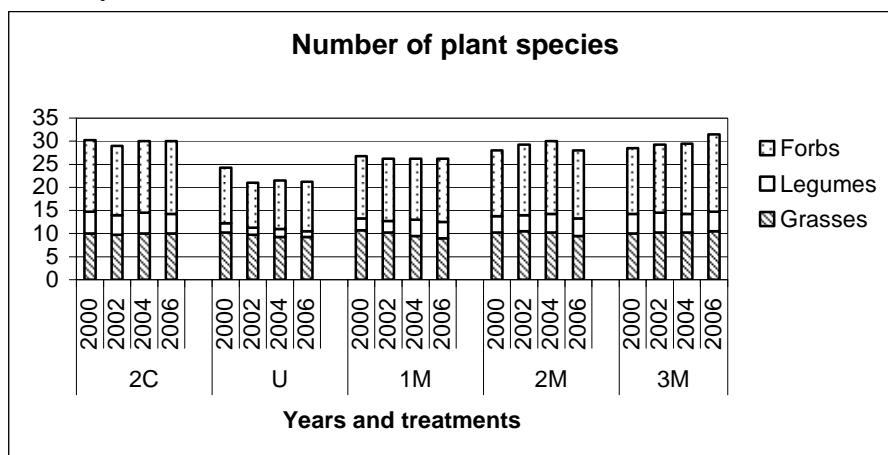

Figure 1. Number of plant species in meadows in the Jizerské hory Mountains in 2000, 2002, 2004 and 2006 either cut twice per year (2C), unmanaged (U), mulched once (1M), twice (2M) or three times (3M) per year.

Prostrate dicotyledonous species (*Trifolium repens*, *Taraxacum* spp., *Plantago lanceolata* and *Leontodon hispidus*) were supported by the frequently managed treatments during the experiment. The cover of legumes was represented mostly by *Trifolium repens* (Table 1) and responded to the defoliation frequency in a similar manner to that reported by Pavlu *et al.* (2006). The cover of legumes was about 20% in all frequently managed meadows.

Table 1. Cover of five functional groups (as percentages of the area sampled) in meadows in the Jizerské hory Mountains in 2000, 2002, 2004 and 2006 either cut twice per year (2C), unmanaged (U), or mulched once (1M), twice (2M) or three times (3M) per year.

Treatments	2C				U				1M				2M				3M			
Years	00	02	04	06	00	02	04	06	00	02	04	06	00	02	04	06	00	02	04	06
Short grasses	11	11	15	10	7	7	18	6	16	16	20	10	11	9	11	6	14	13	12	10
Tall grasses	36	29	26	32	50	41	37	48	40	45	35	44	39	35	35	42	33	28	23	27
Prostrate forbs	19	27	32	29	4	2	5	5	11	11	18	11	14	25	26	14	18	29	29	36
Tall forbs	4	2	3	3	12	10	14	16	5	4	5	8	5	6	6	7	7	4	4	5
Legumes	6	17	19	20	0	1	2	1	2	2	6	6	10	18	21	19	14	23	15	24

In the unmanaged meadows the cover of tall forbs increased (mainly *Anthriscus sylvestris*, *Cirsium arvense*, *Tanacetum vulgare* and *Galium album*) whereas white clover had virtually disappeared (Figure 2).

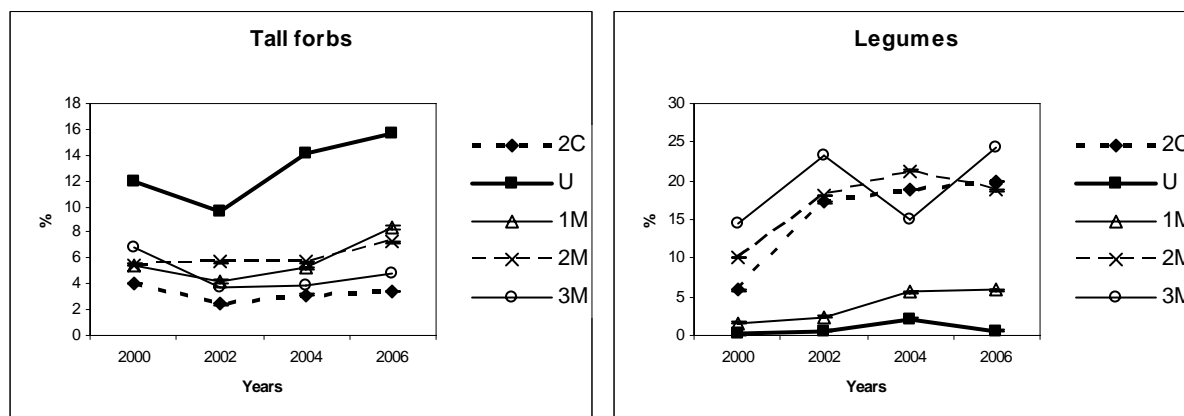

Figure 2. Cover of tall forbs and legumes (as percentages of the area sampled) in meadows in the Jizerské hory Mountains in 2000, 2002, 2004 and 2006 either cut twice per year (2C), unmanaged (U), or mulched once (1M), twice (2M) or three times (3M) per year.

The greatest aboveground plant biomass in the layer above 3 cm of 3-3.5 t DM ha<sup>-1</sup> was found in the unmanaged control meadow (Figure 3). It is possible that this layer of vegetative herbage did not allow light sensitive plant species and seedlings to reach the upper canopy of the meadow which intercepts most of the light. In all of the frequently managed meadows the aboveground plant biomass above 3 cm was relatively low at 0.5-1.0 t DM ha<sup>-1</sup>, whereas in the once-mulched meadow it was greater at 1-1.5 t DM ha<sup>-1</sup>.

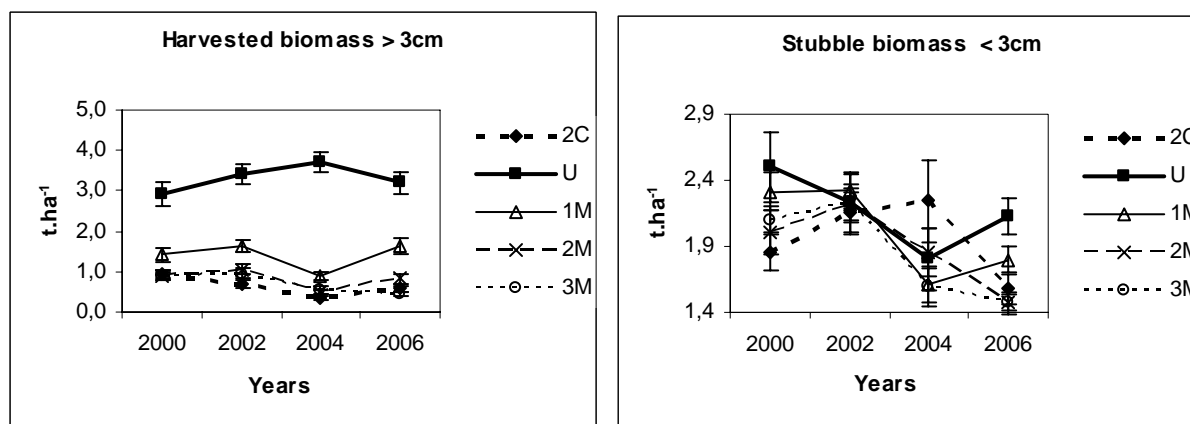

Figure 3. Harvested and stubble biomass (t of dry matter ha<sup>-1</sup>) in meadows in the Jizerské hory Mountains in 2000, 2002, 2004 and 2006 either cut twice per year (2C), unmanaged (U), or mulched once (1M), twice (2M) or three times (3M) per year. Standard errors of the mean are indicated by the vertical lines.

Similarly, Dierschke *et al.* (1991) reported that the greatest standing plant biomass was found in abandoned crops and frequent cutting and mulching reduced standing plant biomass. Also, Ryser *et al.* (1995) showed that the biomass of a standing crop and litter increased with decreasing frequency of cutting. In the present study the lowest belowground plant biomass was found in the unmanaged meadow, but due to high variation between samples the differences between treatments were not significant (Figure 4). A significantly higher proportion of dead material (plant litter or mulched material) was found in the unmanaged control meadow and in the once-mulched meadow. Frequent defoliation substantially reduced

the quantity of harvested biomass (Figure 3) and increased the rate of decomposition of the mulched material which was possibly due to the abundance of young rich nitrogenous plant tissue which can be rapidly degraded (Figure 4).

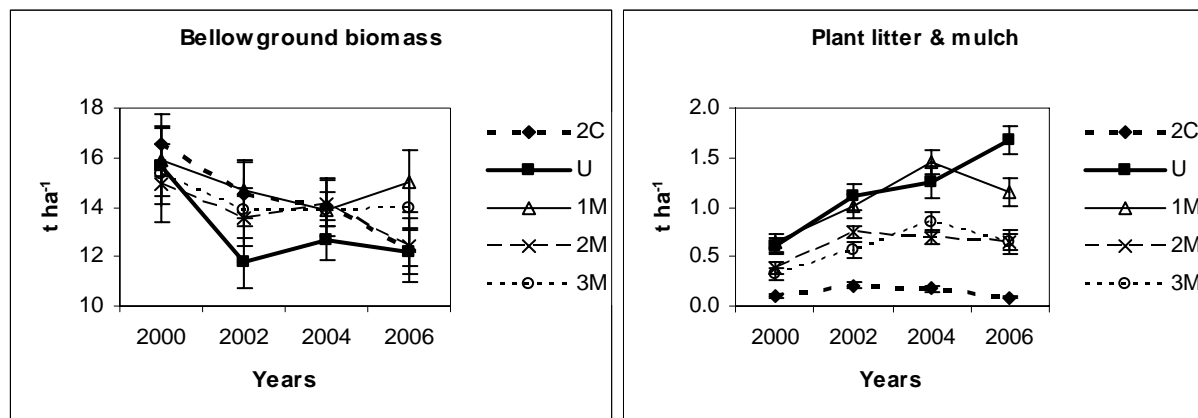

Figure 4. Belowground plant biomass and plant litter including mulched biomass (t of dry matter ha<sup>-1</sup>) in meadows in the Jizerské hory Mountains (abbreviations see Figure 3).

## Conclusions

To prevent ingress of weeds and a decrease of species diversity alternative management strategies should be practiced in areas without management of grasslands for forage production. The results of this study showed that mulching two times per growing season could be sufficient for landscape maintenance in upland grassland areas without agricultural utilization.

## Acknowledgements

This work was supported by the MACR 0002700601.

## References

- Bakker J.P. (1989) Nature Management by Grazing and Cutting. Kluwer Academic Publishers, *Geobotany* 14. Dordrecht, The Netherlands, 173-184.
- Dierschke H., Engels M., Esser G. and Overdieck D. (ed.) (1991) Response of a *Bromus erectus* grassland (*Mesobromion*) to abandonment and different cutting regimes. *Modern Ecology: Basic and Applied Aspects*. Amsterdam, The Netherlands, 375-397.
- Kubat K., Hrouda L., Chrtěk J. jun., Kaplan Z., Kirschner J. and Stepanek J. (eds.) (2002) Key to the flora of the Czech Republic. Academia, Praha, 928 pp.
- Laser H. (2002) Long-term and short-term effects of undisturbed plant succession, mulching, and meadow utilisation on the botanical diversity in a moist *Arrhenatherion elatioris*. *Grassland science in Europe*. 7, 806-807.
- Pavlu V., Hejzman M., Pavlu L., Gaisler J., Nežerková P. and Meneses L (2006) Changes in plant densities in a mesic species-rich grassland after imposing different grazing management. *Grass Forage Sci.* 61, 42-51.
- Pecháčková S. and Krahulec F. (1995) Efficient Nitrogen Economy: Key to the Success of *Polygonum bistorta* in an Abandoned Mountain Meadow. *Folia Geobot. Phytotax.* 30, 211-222.
- Ryser P., Langenauer R. and Gigon A. (1995) Species richness and vegetation structure in a limestone grassland after 15 years management with six biomass removal regimes. *Folia Geobot. Phytotax.* 30, 157-167.
- Santrucek J., Svobodova M. and Brant V. (2002) Changes of botanical composition of grass stands under different types of management. *Rostl. Vyr.* 48, 499-504.

## Stability of perennial grasses in sown swards on the ameliorated lands

Kulakovskaya T.<sup>1</sup>, Laidinen G.<sup>1</sup> and Larionova N.<sup>2</sup>

<sup>1</sup>*International Sakharov Environmental University, 23 Dolgobrodskaya Str., 220009, Minsk, Belarus*

<sup>2</sup>*Institute of Biology, Karelian Research Centre, RAS, 185000, Petrozavodsk, Russia*

### Abstract

The aim of our investigation was to select grass species adapted to reclaimed peat and mineral soils. The study was carried out in South Karelia during 16 years. Successions of monospecific stands of the following grasses were observed: *Festuca pratensis* Huds., *Phleum pratense* L., *Dactylis glomerata* L., *Alopecurus pratensis* L., *Phalaroides arundinacea* (L.) Rausch represented by foreign and local varieties as well as seeds of 30 wild populations. The stands were fertilized with NPK and cut two times per year. With systematic fertilizer application, sown varieties of perennial grasses can be the basis of the grass stand for the 15 years studied. During this period, the monospecific stands of the species studied became multispecific ones with a distinct floristic composition, which depended on the characteristics of the ecotope, the intensity of abiotic and biotic factors, and the ecological and biological characteristics of the species.

Keywords: stability, biodiversity, soil

### Introduction

The creation of long-term meadow communities is one of the ways for rational use of natural resources. The main problem is to increase the stability of the meadow grasses in the prevailing soil and climatic conditions. It is well known that the use of local plant species growing in the regional flora provides success in the recultivation of disturbed lands. Meadow communities undergo continuous changes (Shennikov, 1964; Rabotnov, 1974; Lopatin, 1988), and control of succession is the main problem in creating the optimum grass mixture. This can be done by the use of fertilizers and by grassland management and usage, but such an approach is at risk of being ineffective if the sown grasses are not well adapted to the conditions. In such circumstances, they are quickly replaced by the representatives of the local flora regardless of the fertilizer regime.

### Materials and methods

The aim of our studies was to compare grass species established as pure stands on ameliorated peat and mineral soils. Two experiments were carried out in South Karelia at the research stations of the Institute of Biology, Karelian RC RAS. The first experiment was set up on mineral soil and carried out for a period of 6 years (1987 – 1992). The second experiment was carried out on peat soil for over 16 years. Pure stands of the following grasses were compared: *Festuca pratensis* Huds., *Phleum pratense* L., *Dactylis glomerata* L., *Alopecurus pratensis* L., *Phalaroides arundinacea* (L.) Rausch. These grasses were represented both by local and foreign varieties as well as by thirty wild populations. The initial seed material of the wild gramineous populations was gathered on the meadows of the islands of Onega and Ladoga Lakes. The stands were cut two times per year. Mineral fertilizers were applied at the



following rates: 90 kg N, 60 kg P<sub>2</sub>O<sub>5</sub> and 60 kg K<sub>2</sub>O ha<sup>-1</sup> (mineral soil) or 90 kg N, 60 kg P<sub>2</sub>O<sub>5</sub> and 90 kg K<sub>2</sub>O ha<sup>-1</sup> (peat soil).

## Results and discussion

### *Sown species*

The behaviour of *F. pratensis* differs from that of *P. pratense* (Figure 1). Its mass abundance exceeded 60% until the sixth year and 30% until the ninth year. Then, competitiveness of *F. pratensis* falls abruptly, and its participation in the stand decreased to only 7.3% after 12 years. However, the competitive potential of *P. pratense* weakens from the 12<sup>th</sup> years when its participation in the grass stand decreases abruptly. The same pattern was observed in stands with the foreign varieties. It is necessary to note high aggressiveness of *E. repens* (L.) Nevski in the *F. pratensis* stands, which increased to 75.5% by the 15<sup>th</sup> years following some certain years, *A. pratensis* and *D. glomerata* appeared after some years, but they played no significant role in the phytocenosis. Some prostrate grasses, such as *Poa pratensis* L., *Festuca rubra* L., *Agrostis gigantea* Roth, and *Agrostis canina* L., became stable sward component. *Taraxacum officinale* Wiggs L. composed the main portion of the herbage.

*D. glomerata*, an erect grass has high vigour and was successful in competing with wild grasses during the first years after sowing. When fully fertilized, the content of *D. glomerata* remained rather high until the ninth year. However with the drained peat soils the introduction of *D. glomerata* into the foreign sowing is very slow. Thus, *D. glomerata* remained below 10% in *P. pratense* and *F. pratensis* stands. The content of *D. glomerata* was not stable. Nevertheless, *D. glomerata* maintained a significant presence (12.8 – 36.9%) in its own stands up to the 15<sup>th</sup> year (Fig. 1). This demonstrates high competitiveness of *D. glomerata*. With the increase in age of the *D. glomerata* sward, some of the species that developed in other treatments became established, but none of them had any stable position in the cenosis. *E. repens* abundance was rather high from the 9<sup>th</sup> year. *T. officinale* was more suppressed here than in the stands of *P. pratense* and *F. pratensis*. *T. officinale* spread out only during periods that were unfavourable for *D. glomerata*.

The investigation carried out on mineral oils, proved that humid weather conditions are favorable for the development of hydrophilic grasses such as *A. pratensis* v. *Silver* and *P. arundinacea* v. *Pervenets* (Fig. 2). These species comprised 66% and 54%, respectively, during the second year of the life of the swards in which they were sown. Low content of the sown species in *D. glomerata* v. *Neva* (30%) and *F. pratensis* v. *Suidinskaya* (35%) stands is explained by the unfavorable conditions for the winter survival. The winter season 1987–1988 had a considerable number of thaws which are seen as a casual factor in root decomposition and plant asphyxiation. The latter is responsible for the loss of *D. glomerata* and *F. pratensis* during winter (Raininco, 1968).

The behaviour of the wild populations of grasses differs from that of the varieties during the first years. Their abundance in the stands was determined by the rate of germination and early growth. Considering *A. pratensis* and *F. pratensis*, species with rapidly germinating seeds, the content of sown species is much higher (49.0 and 45.6%) than in *D. glomerata* (11.8%) and *P. arundinacea* (18.3%) which have seeds with slow germination.

Extraordinary behaviour of *F. pratensis* populations proves that they are more adapted to the local environment than the varieties v. *Suidinskaya* from a foreign region. Slow growth in the first years of life was a decisive factor which determined the abundance of the sown grass in the stands. Therefore, at the early stage of stand development, the contribution of the species sown is conditioned by the rate of the seeds' germination and early growth, as influenced by the environmental conditions, particularly water, air and feeding regimes.

Further, the behaviour of the grass stands follows a parabolic trend. First, content of the sown species increased, reaching maximum levels by the third year of the life for *F. pratensis* and the third or fourth year for *D. glomerata*. Then, the content of the sown grasses decreased, with the rate of decrease being more rapid for *F. pratensis* than for *D. glomerata*. *A. pratensis* showed gradual increase in its abundance, reaching maximum levels by the 5<sup>th</sup> year, although with some decrease during the period characterized by precipitation deficiency. By the 6<sup>th</sup> year there were large differences between the sown species in their contribution to the stands, with the content being highest for *A. pratensis* (60.8%), intermediate for *D. glomerata* (39.0%) and *P. arundinacea* (44.0%) and low for *F. pratensis* (12.1%).

### *Forbs*

During the first phases of stand development, active introduction of forbs which mainly consist of annual weeds and perennial wild grasses took place. Compared to the cultivated plants, the wild and weed plants are less vulnerable to the soil and climatic conditions. During the second year of life, the presence of forbs plants increased to maximal. At that stage, forbs participation correlates with the extent of early growth and tillering. The content of forbs was much lower with *A. pratensis* and *F. pratensis*, the species characterized by rapid development (29.8% - 32.7%) than that of the species whose seeds germinate slowly (*D. glomerata* and *P. arundinacea*, 58.5 – 62.4% as shown in Fig. 2). As the stands aged, the perennial grasses replaced the forbs.

During sward development, grasses both sown and unsown replace the forbs. Sown and unsown species are more competitive. The presence of unsown grasses was observed only from the third year and reached 21.2% – 25.8%. The dynamics of the grasses of this group varied. The increase was gradual for *P. arundinacea* and rapid for *F. pratensis*, whilst the content of unsown grasses fluctuated in *D. glomerata* and *A. pratensis*.

### *Unsown grasses*

It should be noted that unsown species developed with all treatments. In general, during the years of the observations, 11 unsown grasses were present. *E. repens* and *Poa trivialis* L. were constantly present in all of the stands. The rate of *E. repens* increased considerably by the 6<sup>th</sup> year. The only exception was *A. pratensis*. *E. repens* became co-dominant in the stands of *D. glomerata* (36.6%) and *P. arundinaceae* (40.0%) and dominant in the stands of *F. pratensis* (52.5%). The abundance of *P. trivialis* decreased in the course of time. The participation of the other unsown grasses not sown was not high during the years of observation (less than 10%). Some increase in their amount occurred as the swards aged. Thus, by the second year of the life, their amount in the stands fluctuated from 3% (*A. pratensis*) to 6% (*F. pratensis*) whilst their amount fluctuated from 5% (*A. pratensis*) to 9% (*F. pratensis*) by the 6<sup>th</sup> year.

## **Conclusion**

During development, the monospecific stands of the species studied became multispecific ones characterized by distinct floristic composition. The floristic composition could be related to the characteristics of the ecotopes sown with abiotic and biotic factors, together with ecological and biological characteristics of the species determining the development and composition of the stands. The stability of the loose-bunch grasses (*Festuca pratensis* and *Phleum pratense*) both in monospecific stands and grass mixtures depends primarily on the conditions of weather, particularly as it affects winter survival. These grasses are likely to dominate the grass stand during a 5–8 year period. *Dactylis glomerata* is likely to be a co-dominant in the swards for a 10-15 year period. For the period of 9-15 years, the presence of

*Alopecurus pratensis* on peat soils remains low (3.4 – 30%), but reasonably stable. With mineral soils, this species was dominant during the 6 years of observation. Stability of the rhizomatous grasses is much higher than that of the loose-bunch ones. Rhizomatous grasses become dominant in sowings from the third year and maintain this situation up to 16 years.

## References

- Lopatin V. D. (1988) Regulation of the meadow cenosis formation during syngeneses. *Botanical Journal*, 73, 3, 391 – 400.
- Rabotnov T. A. (1974) Meadow culture. M., 384 p.
- Shennikov A. P. (1964) Introduction to Geobotany. L., LGU, 447 p.
- Raininko K. (1968) The Effect of Nitrogen Fertilization and Number of Harvestings upon Leys Established with Various Seed Mixtures. Helsinki, 137 p.

## **Weed suppressive capacity of some perennial herbaceous mixtures – a possibility for nonchemical control of Canada thistle (*Cirsium arvense* L.)**

Dimitrova Ts. and Serafimov P.

*Institute of Forage Crops, 5800 Pleven, Bulgaria*

### **Abstract**

The objective of the study was to investigate the weed suppressive capacity of some perennial herbaceous species to reduce the degree of infestation with Canada thistle (*Cirsium arvense* L.) as a possibility for nonchemical control. A four-year study (2001 - 2004) was carried out under field nonirrigated conditions on slightly leached chernozem with the following variants: V<sub>1</sub> – lucerne (*Medicago sativa* L.); V<sub>2</sub> – lucerne + cocksfoot (*Dactylis glomerata* L.); V<sub>3</sub> – lucerne + tall fescue (*Festuca arundinacea* Schreb.); V<sub>4</sub> – lucerne + smooth brome grass (*Bromus inermis* L.); V<sub>5</sub> – lucerne + wheatgrass (*Agropyron desertorum* Fisch Schult.).

In this study the perennial herbaceous mixtures (lucerne + cocksfoot; lucerne+smooth brome grass; lucerne + wheatgrass) grown as a wedge in crop rotation had a high weed suppressive capacity and contributed to reduce the infestation with *Cirsium arvense* L. The phytosanitary role of the perennial herbaceous mixtures have a considerable share in the strategies of controlling *Cirsium arvense* L. in an ecological aspect, meeting the requirements of contemporary systems of organic farming.

Keywords: Canada thistle (*Cirsium arvense* L.), lucerne (*Medicago sativa* L.), perennial grasses, mixed stands, nonchemical control

### **Introduction**

Heavy infestation with Canada thistle (*Cirsium arvense* L.) becomes an increasing problem in the European countries. This perennial, root-shoot weed is on the list of the economically important pests of agricultural crops in Bulgaria characterized by large-scale spread and as a reservoir of bacteria and viruses. The high regenerative capacity of underground rhizomes and seed productivity are directly related to the high invasive capacity of the weed. Additionally, a high presence of labile carbohydrates in the roots enables the plant to regenerate from buds on root fragments as short as 10 mm (Hamdoun, 1972). According to studies of McAllister and Haderlie (1985) the amount of labile carbohydrates in the roots of *Cirsium arvense* L. varies throughout the season. In experiments undertaken under controlled conditions by Gustavsson (1997) the minimum dry weight of underground regenerative organs - the time when the plant is assumed to be most susceptible to removal of aboveground plant tissues- occurs when the aerial shoots have about 8 - 10 expanded leaves. Hence, control events aiming at weakening the regenerative capacity is expected to be most effective at this stage of the weed. However, according to the studies of Bourdot *et al.* (1998), late season mowing reduced the overwintering root biomass more than early or mid-season mowing. In spite of established possibilities for chemical control of this weed (Veljkovic *et al.*, 2005) the contemporary systems of organic farming require studies on environmentally friendly approaches. Within this scope, Graglia *et al.* (2006) studied the effect of repeated, but practical regimes of cultivation and mowing against *Cirsium arvense* L. and also the influence of a competitive crop (red clover) to suppress the regrowth of weed shoots.

According to Dimitrova and Tomov (1993), perennial grasses, after the first year of their growing, possess high competitive capacity with regard to weeds. The mixed stands of

perennial legumes and grasses use abiotic environmental factors more efficiently and are characterized by a lower degree of weed infestation (Vasilev, 2004, Dimitrova, 2005). The competitive interrelations among species in herbaceous associations in which the weed vegetation is also included, have not been sufficiently studied yet (Stancheva, 2000). The objective of the study was to determine the weed suppressive capacity of some perennial herbaceous species in order to reduce the degree of infestation with Canada thistle (*Cirsium arvense* L.) as a possibility for nonchemical control.

## Material and methods

The study was carried out during the period 2001 - 2004 in the experimental field of the Institute of Forage Crops, Pleven on slightly leached chernozem. The trial was conducted under nonirrigated conditions, by the long plot method, with a harvest plot size of 5 m x 2 m and with the following treatments: V<sub>1</sub> – lucerne (*Medicago sativa* L.); V<sub>2</sub> – lucerne+cocksfoot (*Dactylis glomerata* L.); V<sub>3</sub> – lucerne + tall fescue (*Festuca arundinacea* Schreb.); V<sub>4</sub> – lucerne + smooth brome grass (*Bromus inermis* L.); V<sub>5</sub> – lucerne + wheatgrass (*Agropyron desertorum* Fisch Schult.). The sowing was conducted in spring with the following varieties and sowing rates: lucerne Pleven 6 – 20 kg ha<sup>-1</sup> for pure stand; cocksfoot Dabrava – 12 kg ha<sup>-1</sup>; tall fescue Albena – 14 kg ha<sup>-1</sup>; smooth brome grass Nika – 18 kg ha; wheatgrass – local population – 11 kg ha<sup>-1</sup>. The component ratio was 1:1 in the mixed stands. The pure lucerne stand was mown at the early flowering stage. In the first year the mixed stands were mown at the same stage, but in the following years the first cut was taken at early heading of the grass component and the following cuts at lucerne budding. The swards were mown as follows: 2 cuts in 2001 (June and August); 4 cuts in 2002 (May, June, July and August); 3 cuts in 2003 (May, June and August) and 3 cuts in 2004 (May, June and July). Immediately before every cut a botanical analysis was performed with recording of *Cirsium arvense* L. infestation degree in permanent sampling plots (1m<sup>2</sup>) by the quantity-weight method and determination of dry biomass productivity of the swards. The results were processed statistically by the method of variance analysis.

## Results and discussion

It is evident from the analysis of weed infestation degree by years (Table 1) that it was highest in the year of stand establishment, varying from 12 to 15 stems/m<sup>2</sup> for the different treatments.

Table 1. Effect of some perennial herbaceous mixtures on the degree of infestation with *Cirsium arvense* L. (stems/m<sup>2</sup>)

Treatments	2001 stems/m <sup>2</sup>	2002 stems/m <sup>2</sup>	2003 stems/m <sup>2</sup>	2004 stems/m <sup>2</sup>	Reduced stems compared to 1 <sup>st</sup> year,%
V <sub>1</sub> - <i>Medicago sativa</i>	15	10	7	5	67
V <sub>2</sub> - <i>M.sativa</i> + <i>Dactylis glomerata</i>	12	8	5	2	83
V <sub>3</sub> - <i>M.sativa</i> + <i>Festuca arundinacea</i>	14	11	10	8	43
V <sub>4</sub> - <i>M.sativa</i> + <i>Bromus inermis</i>	14	10	7	3	79
V <sub>5</sub> - <i>M.sativa</i> + <i>Agropyron desertorum</i>	13	10	6	3	77
GD 5%	5.47	4.23	4.46	3.37	
GD 1%	7.96	6.16	6.48	4.90	
GD 0.1%	11.96	9.25	9.74	7.36	

This was due to the slow rate of growth and development of the components in the swards and hence the slight effect on the weed. During the next three years there was a suppressive

effect of the swards negatively reflecting on the number of formed shoots of *Cirsium arvense* L. In the fourth year their density considerably decreased within the range of 3 to 8/m<sup>2</sup>. This was due to the biological and morphological characteristics of the components – early and quick rate of growth, good leafiness, herbage length, high tillering capacity and multiple cuts. The weed stem reduction in late experimental period was different from the first year and varied within the range of 67% (for the pure lucerne stand - V<sub>1</sub>) to 83% (for the mixed stand of lucerne + cocksfoot – V<sub>2</sub>). This was mainly due to the density of formed swards, which depended on both component intertolerance and their aggressiveness. Among the studied grasses cocksfoot had the greatest aggressiveness followed by smooth brome grass and wheatgrass (Dimitrova, 2005). The lowest degree of *Cirsium arvense* L. stem reduction (43%) was observed in the mixture of lucerne+tall fescue due to the biological incompatibility between the two species. Lucerne strongly suppressed tall fescue, so its participation in the sward was insignificant and the empty spaces favoured weed development. The great aggressiveness of lucerne could be explained by its capacity to release a great quantity of inhibiting substances (Grant and Sallans, 1964). On the other hand, according to Gibson and Newman (2001) tall fescue has low competitive capacity due to the fact that it requires higher average diurnal temperatures for active growth in early and late vegetation. The data on the effect of perennial herbaceous mixtures on the formation of aboveground fresh biomass by *Cirsium arvense* L. (Table 2) followed the same relation as the number of stems.

Table 2. Effect of some perennial herbaceous mixtures on the formation of aboveground fresh biomass by *Cirsium arvense* L. (gram/m<sup>2</sup>)

Variants	2001	2002	2003	2004	Reduced fresh biomass compared to 1 <sup>st</sup> year,%
	g m <sup>-2</sup>	g m <sup>-2</sup>	g m <sup>-2</sup>	g m <sup>-2</sup>	
V <sub>1</sub> -Medicago sativa	1113	455	288	205	82
V <sub>2</sub> -M.sativa + Dactylis glomerata	967	105	58	36	96
V <sub>3</sub> -M.sativa + Festuca arundinacea	1057	502	320	166	84
V <sub>4</sub> -M.sativa + Bromus inermis	1118	131	90	51	96
V <sub>5</sub> -M.sativa + Agropyron desertorum	1090	143	94	58	95
GD 5%	3262	142	89	49	
GD 1%	4746	207	129	71	
GD 0.1%	7132	311	194	106	

My opinion: In this table figures after the comma are unimportant in comparison with the variation between treatments and within replicates: I suggest no figures after the comma. In the year of sward establishment, when they had a low competitive capacity, there was no mathematical significance of the differences with regard to the weight of aboveground fresh biomass of the weed. In the next years the competition between the cultivated components and the weed with regard to the important vital factors (nutrients, light, and living space) and the more frequent cuts (3 - 4 per growing season) resulted in a reduction of the aboveground shoot weight. The differences in shoot weight among the different variants of the mixed stands of lucerne with cocksfoot, smooth brome grass and wheatgrass were important compared to the pure lucerne stand. In the fourth year the reduction of aboveground weed biomass in these variants was 95 to 96%, whereas in the pure stand and the mixture of lucerne+tall fescue these values were between 82 to 84%. This fact, as in the previous case, could be explained by the biological and morphological characteristics of components and their interrelations in the sward. Based on the results from this study one might assume that the strategy for establishment and growing of lucerne in mixed stands with some perennial grasses as a separate wedge in the crop rotation provides a possibility for non-chemical control of *Cirsium arvense* L. The effect of the application of this strategy is many-sided and finds expression in the great reduction of weed shoot number and biomass, as well as in the

strong suppression of the weed in the lowest sward layer by which it does not reach the seed formation stage.

Table 3. Dry biomass productivity of lucerne in pure and mixed stands with perennial grasses, kg ha<sup>-1</sup>

Variants	2001	2002	2003	2004	average 2001-2004	
	kg ha <sup>-1</sup>	kg ha <sup>-1</sup>	kg ha <sup>-1</sup>	kg ha <sup>-1</sup>	kg ha <sup>-1</sup>	%
V <sub>1</sub> -Medicago sativa	2560	12010	8300	10260	8282	100
V <sub>2</sub> -M.sativa + Dactylis glomerata	1950	12400	12800	13100	10062	121
V <sub>3</sub> -M.sativa + Festuca arundinacea	1020	10320	10080	11120	8135	98
V <sub>4</sub> -M.sativa + Bromus inermis	1250	11710	12100	12700	9440	114
V <sub>5</sub> -M.sativa + Agropyron desertorum	1430	11030	10420	11900	8695	105
GD 5%	208	892	638	2849	1731	
GD 1%	303	1295	929	1396	4145	2427
GD 0.1%	456	1950		6229	3430	

This is a limiting factor of its multiplication. Besides their phytosanitary role, the mixed stands of lucerne with cocksfoot, smooth brome grass and wheatgrass also have higher productivity of dry biomass, as compared to the pure stands (Table 3). On average for the four-year period of study under the real conditions of the trial, DM yield was 5 to 21% higher with lucerne+cocksfoot as the best combination.

## Conclusions

The perennial herbaceous mixtures of lucerne with some grasses (cocksfoot, smooth brome grass and wheatgrass) grown as a wedge in crop rotation have a high weed suppressive capacity and contribute to the reduction of the infestation with *Cirsium arvense* L. Phytosanitary role of the perennial herbaceous mixtures has a share in the strategies of controlling *Cirsium arvense* L. in an ecological aspect meeting the requirements of the contemporary systems of organic farming.

## References

- Bourdôt GW, Leathwick DM, Hurrell GA, Savill DJ and O'Callaghan M (1998) Relationship between aerial shoot and root biomass in Californian thistle. In: *Proceedings of the Fifty First New Zealand Plant Protection Conference* (ed. MO'Callaghan), Hamilton, New Zealand, 28-32. New Zealand Plant Protection Society, Rotorua, New Zealand.
- Dimitrova Ts. (2005) Study of weed suppressive ability and productivity of Lucerne grown in pure and mixed stands with perennial grasses, *Plant Science*, 42, 461-468
- Dimitrova Ts., Tomov P. (1993) Studies on phytosanitary role of some perennial grasses, Proc. Scientific Works, HAI, Plovdiv, 38, 3.
- Gibson D.J. and Newman J.A. (2001) *Festuca arundinacea* Schreber (F.elatior L. ssp arundinacea Schreber and Hackel), *Journal of Ecology*, 89, 2, 304.
- Graglia E., Melander B. and Jensen R.K. (2006) Mechanical and cultural strategies to control *Cirsium arvense* in organic arable cropping systems, *Weed research*, vol. 4, 304-312.
- Grant EA and Sallans WG (1964) *J.Brit. Grassland Soc.*, 19.
- Gustavsson AMD (1997) Growth and regenerative capacity of plants of *Cirsium arvense*. *Weed Research* 37, 229-236.
- Hamdoun AM (1972) Regenerative capacity of root fragments of *Cirsium arvense*. *Weed Research* 12, 128-136.
- Mc Allister RS and Haderlie LC (1985) Seasonal variations in Canada thistle (*Cirsium arvense*) root bud growth and root carbohydrate reserves. *Weed Science* 33, 44-49.
- Stancheva I. (2000) Ecological bases of agriculture. Sofia, Pensoft.
- Vasilev E. (2004) Forage productivity of Bulgarian lucerne cultivars in mixtures with grasses. *Grassland Science in Europe*, vol.9, 401-403.
- Veljkovic, B., Vrbniaanin S. and Stevanovic Z.D., (2005) Biological properties of *Cirsium arvense* (L.) Scop. and possibilities of control, 13<sup>th</sup> EWRS symposium, Bari – Italy, 19-23 June 2005, CD-R.

# Control of broad-leaved dock on organic grassland farms

Poetsch E.M. and Griesebner C.

*Agricultural Research and Education Center for Agriculture, Raumberg-Gumpenstein, 8952  
Irdning, Austria*

## Abstract

Investigations are reported on different aspects of broad-leaved dock control, which is still the main weed on Austrian grassland. In view of the large number of organic and integrated farms, which are not allowed to use herbicides, the main focus was given on mechanical dock control. The Mini-WUZI, an Austrian innovation, was tested for performance characteristics and for efficiency. It was shown, that there is only a minor risk of regeneration from treated dock roots and root parts. Compared with manual methods, this promising motorised system indicates a high efficiency with the ability to remove up to 400 dock plants h<sup>-1</sup>.

Keywords: dock control, vegetative regeneration, forage quality, organic farming

## Introduction

Broad-leaved dock is still the main weed problem on European grassland. Measures for biological, mechanical and chemical weed control are used to regulate and fight against this very resistant herb, which has an inferior feed value with low digestibility and low energy concentration (Bohner, 2001). Organic and integrated farms, which take part in the Austrian programme for an environmentally friendly agriculture, are not allowed to use herbicides. These farms have therefore an increasing interest in preventive measures and in new and reliable treatments to reduce or to destroy broad-leaved dock (Poetsch, 2002; Poetsch, 2003). Some innovative technical solutions like the so called Mini-WUZI, a motorised milling cutter system, have been developed during recent years to increase the efficiency of mechanical dock control (Poetsch, 2004). In the meantime the Mini-WUZI is produced commercially on a small scale and available via a number of machinery rings in Austria.

## Materials and methods

In order to detect and to evaluate the dock contamination on a farm level, a simple pictorial scheme was developed and tested in practice (Figure 1). Each pasture and meadow of an organic test farm with a size of about 30 ha was assigned to the categories no docks, low, medium and high proportion of docks. The field recordings were then digitised and transformed into real area values by using GIS. A farm map, illustrating the different levels of the dock problem was created both to raise the farmer's awareness by identifying and pointing out the "hot dock spots" and to provide a basic tool for further control measures.



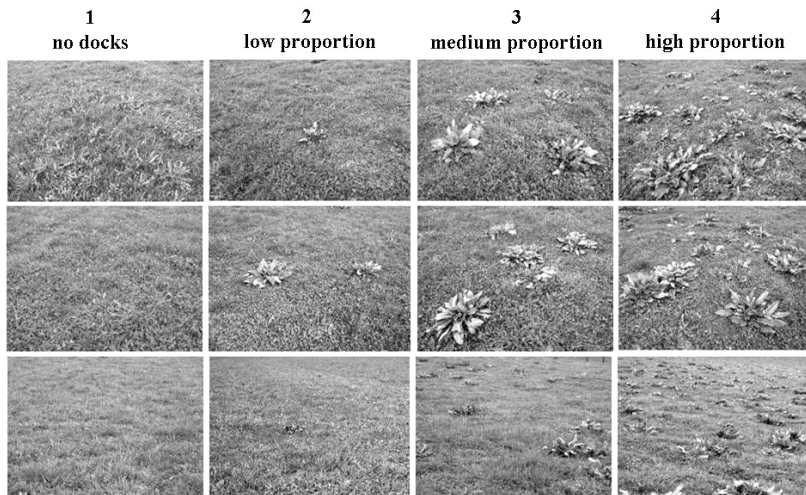

Figure 1: Simple pictorial scheme for different dock proportions

Special investigations have been carried out at HBLFA Raumberg-Gumpenstein to get detailed information about the performance characteristics and efficiency of the promising Mini-WUZI method (Figure 2). Attention was given to the possible risk from the vegetative regeneration of dock roots and root parts after the mechanical treatment. Residual parts of dock roots from the treated fields and roots, sliced to pieces with length from 0.5 to 5.0 cm, were collected and cultivated in boxes. After a period of four weeks the regeneration capacity of the dock roots and root parts was recorded and analysed.

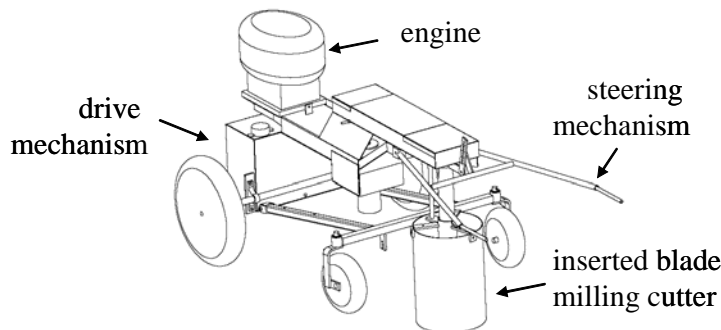

Figure 2: Schematic design of the Mini-WUZI, a motorised milling cutter system for mechanical dock control

## Results and discussion

About 18% of the total test farm area, which amounted to about 30 ha, was identified as affected by broad-leaved dock plants at different proportions. The visualised distribution clearly showed that there was a stronger concentration of docks on pastures and meadows near the farm and barn area as well as on fields which are frequently used for grazing (Figure 3, left part). All grassland areas far from the farm centre and therefore rarely used as pastures and mostly fertilized at a lower intensity showed significantly lower proportions of docks (Figure 3, right part). In combination with the specific management history of the farm, the visualization and quantification of the dock problem provide the farmers with basic information about the reasons for the appearance and spread of docks (overgrazing, sward damage, excessive nutrient supply, storage of solid manure etc.) and it allows them to prepare an adapted plan for dock control with different measures.

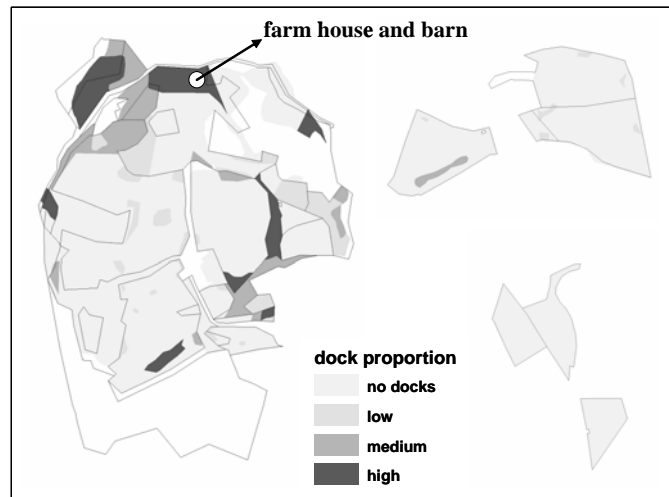

Figure 3: Proportion of broad-leaved dock on pastures and meadows of an organic test farm in Austria (30.4 ha )

For organic farms such a plan should include both preventive measures to avoid the spreading of docks within the farm and different biological and mechanical treatments. The activity of dock leaf beetles (*Gastrophysa viridula*) depends on many factors and can not be seen as a reliable and sustainable method to regulate docks (Hahn and Kromp, 2001). Therefore organic farmers concentrate on mechanical methods to dig out or to finely chop dock plants, after ploughing up grassland. These approaches are limited by the site conditions (steepness and shallow soil) and specific regulations in the Austrian environmental programme for agriculture.

Up to now special forks were mainly used to dig out dock plants by hand. This is both hard work and a time-consuming activity. In 1996 a very innovative Austrian organic farmer constructed a motorised dock extractor named Ampfer-WUZI. Some studies indicated the high capacity and efficiency of this prototype, which unfortunately has never reached the stage of a commercial production. In the meantime the so called Mini-WUZI has been developed and seems to be a promising and reliable method for the mechanical dock control. Some important technical characteristics of both machines are presented in Table 1. The high dock performance with up to 400 plants h<sup>-1</sup> makes it possible to treat even larger fields with higher proportion of dock. The prize for the Mini-WUZI is at €7,000,- but it is also available via a number of machinery rings at costs of €15,- per hour of operation.

Table 1: Basic technical characteristics of the Ampfer-WUZI and Mini-WUZI system

	Ampfer-WUZI	Mini-WUZI
engine output	29.4 kW	9.6 kW
total weight	3,700 kg	70 kg
milling head rotation	app. 1,000 min <sup>-1</sup>	app. 1,800 min <sup>-1</sup>
diameter of the milling hole	20 cm	20 cm
depth of the milling hole	15 cm	15 cm
dock performance	up to 600 dock plants h <sup>-1</sup>	up to 400 dock plants h <sup>-1</sup>

It is well known that besides their enormous seed productivity, docks are also able to regrow via regeneration buds on their strong root system (Kutschera und Sobotik, 1992; Poetsch and Krautzer, 2002). Farmers worry about this risk of regrowth, which can be noticed after ploughing and cultivation and may also occur after mechanical measures of dock control. Our study showed, that about 4% of the 300 cultivated roots/root parts regenerated again to produce viable dock plants. This regeneration activity was observed for all the tested root lengths, with the exception of the 0.5 cm root slices. The milling size of the dock roots should therefore be as small as possible to avoid a stronger dock spreading after a mechanical control treatment.

The results also indicated that the regeneration of dock roots only appeared at the upper part of the root system from 0 to about 12 cm. This confirms the practical recommendation which advises to remove or to destroy at least the first 12 to 15 cm of the dock root system. This basic requirement can be fulfilled by the Mini-WUZI-technique if the soil is deep enough and not too stony.

## Conclusions

The visualisation of the appearance and distribution of broad-leaved dock on a farm level can be an important tool to raise the farmer's awareness and to set up a plan for future control measures and treatments. The proposed pictorial scheme is a simple and realisable instrument to rapidly record the status quo of the dock problem.

Special investigations have been carried out to get detailed information about performance characteristics and efficiency of the so called Mini-WUZI, which seems to be a practical and efficient method for the mechanical control of docks. This Austrian innovation shows an impressive performance and is now available via a number of local machinery rings. The tests indicated that the degree of milling of the treated dock plants and dock roots is sufficient to avoid strong regeneration, a factor of major concern for farmers. The treated patches should be reseeded to close the sward gaps and to compete against other weeds.

## References

- Bohner A. (2001) Physiologie und futterbaulicher Wert des Ampfers. Bericht zum 7. Alpenländischen Expertenforum „Bestandesführung und Unkrautregulierung im Grünland – Schwerpunkt Ampfer“, BAL Gumpenstein, 39-44
- Hahn P. und B. Kromp (2001) Ampferregulierung mittels Ampferblattkäfer: erste Ergebnisse. Bericht zum 7. Alpenländischen Expertenforum „Bestandesführung und Unkrautregulierung im Grünland – Schwerpunkt Ampfer“, BAL Gumpenstein, 63-67
- Kutschera L. und Sobotik M. (1992) Wurzelatlas mitteleuropäischer Grünlandpflanzen. Band 2: Pteridophyta und Dicotyledoneae, Teil 2, Gustav Fischer Verlag, Stuttgart-Jena-New York, 261 pp.
- Poetsch E.M. (2002) So bekämpfen Sie den Ampfer erfolgreich. *top agrar Österreich Journal* (6), 36-39.
- Poetsch E.M. (2003) Möglichkeiten der mechanisch/biologischen Ampferbekämpfung. In: Tagungsband zu dem Expertenkolloquium „Strategien zur Regulierung von Wurzelunkräutern im ökologischen Landbau“. Braunschweig 18.-19.02.2003, Landbauforschung Völkenrode, Sonderheft 255, 63-67
- Poetsch E.M. (2004) Vom WUZI zum Mini-WUZI – das Erfolgskonzept der mechanischen Ampferbekämpfung. *Der fortschrittliche Landwirt* (20), 14-15
- Poetsch E.M. and B. Krautzer (2002) The influence of ruminal digestion and farm manure on the germination development of seeds of broad-leaved dock (*Rumex obtusifolius* L.). EGF-Symposium 2002. La Rochelle, 25.-30.05.2002, Volume 7, Grassland Science in Europe, 386-387

# Addition of humic substances improves yield and nutrient uptake efficiency of grasslands

Verlinden G.<sup>1</sup>, Mertens J.<sup>2</sup>, Pycke B.<sup>1</sup>, Debersaques F.<sup>1</sup>, Bries J.<sup>2</sup>, Baert G.<sup>1</sup> and Haesaert G.<sup>1</sup>

<sup>1</sup>*University College Ghent, Faculty of Biosciences and Landscape Architecture, Voskenslaan 270, B-9000 Ghent, Belgium,*

<sup>2</sup>*Soil Service of Belgium, W. de Croylaan 48 ,B-3001 Heverlee, Belgium*

## Abstract

As organic matter content of Flemish grasslands continues to decrease and as grassland organic matter contains a relatively low content of humic acids compared to organic matter of arable land, pot and field experiments were set up to investigate the effect of the addition of external humic acids preparates on the yield and nutrient uptake efficiency of grass. Therefore, concentrated solutions of humic and fulvic acids were either applied in combination with mineral fertilizers or were directly incorporated into the mineral fertilizers. In general, addition of humic substances in combination with mineral fertilizers resulted in a positive effect on the first cut mostly with repercussions on the yield of following grass cuts. The grass quality was hardly affected by the application of humic substances whereas nutrient uptake often increased with humic acid application.

Key words: humic acids, organic matter, fertilization, grassland production, grass quality

## Introduction

In Flanders, the organic matter content in more than 30% of the permanent grasslands is lower than the optimal value defined by the Soil Service of Belgium (Vandenauweele *et al.*, 2004). The organic matter status of a soil can be improved by the application of external sources of organic matter (manure, slurry, compost, ...) but due to Flemish legislation restrictions, the use of large amounts of these products is impossible because of their relatively high total nitrogen and phosphorous content. A lot of the beneficial characteristics of organic matter are associated with humic substances (i.e. humic and fulvic acids), which are formed during the humification process of organic material. Therefore, the application of biologically stable humic substances, extracted from natural organic sources can provide many of the advantages of conventional organic matter sources, without the problems of excessive nutrient supply as described above (Burns *et al.*, 1986). The purpose of this work was to determine the potential of humic substances (including both humic and fulvic acids) to affect yield, grass quality and nutrient uptake of Italian Raygrass under flemish fertilization regimes.

## Materials and methods

One pot experiment and two field experiments were conducted to study the effect of humic substances on grass yield and nutrient uptake. In all cases, a pure and stable commercial prepate named Humifirst was used, containing 12% humic acids and 3% fulvic acids extracted from leonardite. Humifirst was either applied as a liquid solution (50 l/ha) or either incorporated in mineral fertilizers (1,5 to 3,5% of Humifirst).

*Pot experiment:* A pot experiment with Italian Raygrass (cv. Meroa) was carried out in the growth chamber (22°C/ 14°C day/night temperature) to study the effect of liquid and

incorporated Humifirst on the yield and nutrient uptake of grass. Pots were filled with 1 kg of a sandy loamy soil from Bottelare (pH-KCl = 5,4, 0,8 % C, 700 ppm N, 331 ppm P, 202 ppm K, 141 ppm Mg, 3,31 meq/100g CEC). Mineral fertilization corresponding with 400 kg/ha 14-14-14 NPK with or without incorporated Humifirst was mixed into the upper soil layer before sowing. After sowing of the grass, the soil was wetted with water or a Humifirst solution and the pots were placed in the growth chamber. The three treatments (1: mineral fertilization without Humifirst, 2: mineral fertilization with 50 l/ha Humifirst liquid, 3: mineral fertilization with 1,5% Humifirst) were replicated four times. A dose of 50 l/ha Humifirst liquid corresponds with 8,25 kg/ha humic substances, while 400 kg/ha 14-14-14 with 1,5% Humifirst corresponds with 4,1 kg/ha humic substances. Three grass cuts were performed during the experiment and the fresh grass weight was measured. Grass samples were dried at 70°C for 24 h, weighed and ground for chemical analysis (N, P, K, Mg, Na, Ca, S, B, Mn, Zn, Cu).

*Field experiments:* Two field trials were carried out in 2006 to evaluate the results of the pot experiment under field conditions. The experiments were carried out on permanent grassland, one located in Bottelare near Ghent and one in Hoogstraten in the north of Belgium (30 km northeast of Antwerp). Fertilization was performed according to fertilization recommendations of the Soil Service of Belgium based on chemical soil analysis. Three treatments were installed on the field trial in Bottelare in a randomized block design with four replications: mineral fertilization, mineral fertilization plus foliar application of 50 l/ha Humifirst liquid (corresponding with 8,6 kg/ha humic substances), mineral fertilization with incorporated Humifirst at 3,5% (corresponding with 14,9 kg/ha humic substances). In the field trial at Hoogstraten, mineral fertilization as well as slurry were included in the experiment and following five treatments were installed in a randomized block design with four replications: mineral fertilization, mineral fertilization with incorporated Humifirst at 3,5% (corresponding with 5,6 kg/ha humic substances), slurry + mineral fertilization, slurry + mineral fertilization with incorporated Humifirst at 3,5%, slurry mixed with 50 l/ha Humifirst + mineral fertilization. The amount of grass cuts in the field trials depended on the weather and grass conditions on each field (2 grass cuts in Bottelare, 4 grass cuts in Hoogstraten). Fresh yield of each plot was determined by cutting a subplot of 13 m<sup>2</sup> and one grass sample per plot was taken to measure dry matter content and mineral composition. For a selection of treatments on the field trial in Bottelare, grass quality was measured as well.

The statistical package SAS (SAS Institute Inc. 1985) was used for analysis of variance on all data sets of the pot and field trials to determine significance of the treatment effects. A Tukey-test was then used to compare treatment means at the 0,05 probability level.

## **Results and discussion**

In general, humic acids (in combination with mineral fertilizers) generated the same effect on *grass yield* throughout the different pot and field experiments, irrespective of the use of liquid or incorporated humic acids. Application of humic acids before the first cut resulted in a clear response at the first cut and a regression in the second and third cut (Table 1). Special attention has to be made to the specific weather conditions of the summer of 2006: a very dry period in July was followed by a wet period in August. Grass cuts after the dry period in July, for ex. the fourth grass cut in Hoogstraten, clearly took advantage of the application of humic acids (+14% fresh weight). Total yield at the end of the experiments (Table 1) was increased in 5 out of the 7 treatments with application of humic acids (-1,6 to +21% fresh weight compared to control, with an average of + 8 %).

Table 1. Grass yield in the pot experiment and the field trials in Bottelare and Hoogstraten (2006)

	1st grass cut		2nd cut		3th grass cut		4th grass cut		Total	
	FMY	DMY	FMY	DMY	FMY	DMY	FMY	DMY	FMY	DMY
<i>Pot experiment</i>	<i>g/pot</i>	<i>g/pot</i>	<i>g/pot</i>	<i>g/pot</i>	<i>g/pot</i>	<i>g/pot</i>	<i>g/pot</i>	<i>g/pot</i>	<i>g/pot</i>	<i>g/pot</i>
control	12,7	1,5	12,0	1,4	12,3	1,0			36,3	4,1
HF liquid	17,0	1,6	13,2	1,3	11,9	1,2			42,0	4,1
HF incorp. 1,5%	15,8	1,6	12,0	1,3	10,5	1,1			37,2	3,7
<i>Field trial Bottelare</i>	<i>t/ha</i>	<i>t/ha</i>	<i>t/ha</i>	<i>t/ha</i>	<i>t/ha</i>	<i>t/ha</i>	<i>t/ha</i>	<i>t/ha</i>	<i>t/ha</i>	<i>t/ha</i>
control	23,8	3,42	26,4	5,71					50,2	9,13
HF liquid	25,9	3,84	25,2	5,36					51,1	9,20
HF incorp. 3,5%	24,9	3,53	24,5	5,09					49,4	8,61
<i>Field Hoogstraten</i>	<i>t/ha</i>	<i>t/ha</i>	<i>t/ha</i>	<i>t/ha</i>	<i>t/ha</i>	<i>t/ha</i>	<i>t/ha</i>	<i>t/ha</i>	<i>t/ha</i>	<i>t/ha</i>
control	12,4	2,53	11,8	2,18	7,0	1,70	10,9	1,71	42,1	8,11
HF incorp. 3,5%	21,5*	3,60	10,3	1,89	6,2	1,46	12,0	1,95	49,7	8,90
control slurry	10,8	2,17	10,6	1,98	6,2	1,52	12,8	1,94	40,4	7,60
slurry mixed with HF liquid	15,3	2,56*	8,5	1,83	5,0	1,29	11,8	1,94	40,4	7,63
slurry + HF incorp.	20,5*	3,61	9,4	1,78	6,9	1,57	12,1	1,94	48,8	8,90

FMY = Fresh matter yield, DMY = Dry matter yield, HF = Humifirst

\*significant difference between the control and humic acid treatment with  $\alpha = 0,05$

On the field trial in Hoogstraten, humic substances were applied in combination with slurry too. The general trend, as described above, was still observed. Incorporation of humic substances into the mineral fertilizer combined with the application of slurry resulted in a yield increase of 90% (fresh weight) or 66% (dry weight) for the first cut and 21% (fresh weight) or 17% (dry weight) during the whole growing season! When humic substances were mixed as a solution into the slurry, the effect was less pronounced: a yield increase of 41% (fresh weight) or 18% (dry weight) for the first cut and no effect during the whole growing season.

In line with the yield response and the dilution effect, the effect of humic acids on the *mineral composition* of the grass in the *pot experiment* was more pronounced for the second and third grass cut than for the first grass cut. The total macro-nutrient uptake of the grass during the experiment was clearly the highest for the humic acid treatments: N, P and K-uptake respectively increased with 10, 23 and 14% for the Humifirst liquid treatment and with 20, 12 and 9% for the incorporated Humifirst treatment. The effect of humic acids on the uptake of micro-nutrients was less pronounced. The uptake of Mn still increased with 13 to 30%, but the uptake of B, Fe and Zn was more or less the same for all treatments. The nutrient uptake after humic acid application *in the field* was different for the two field trials. In Bottelare, nutrient uptake was not affected by humic acid application but in Hoogstraten, a significant effect on nutrient uptake of the grass was measured (chemical analyses only for the first and third grass cut). While at the first grass cut the dry matter yield was 42% higher for the treatment with incorporation of 3,5% Humifirst in the mineral fertilizer compared to the control treatment, the nutrient uptake far exceeded this increase: 72%, 98% and 80% for N, K<sub>2</sub>O and P<sub>2</sub>O<sub>5</sub> uptake and 76%, 87% and 114% for Mn, Cu and Zn uptake (Figure 1). In the third grass cut, dry matter yield for the humic acid treatment was 14% less than the control but the nutrient uptake only decreased 3% (N) to 14% (MgO). Copper and Zinc uptake was even higher (+ 8 and 7%) for the humic acid treatment.

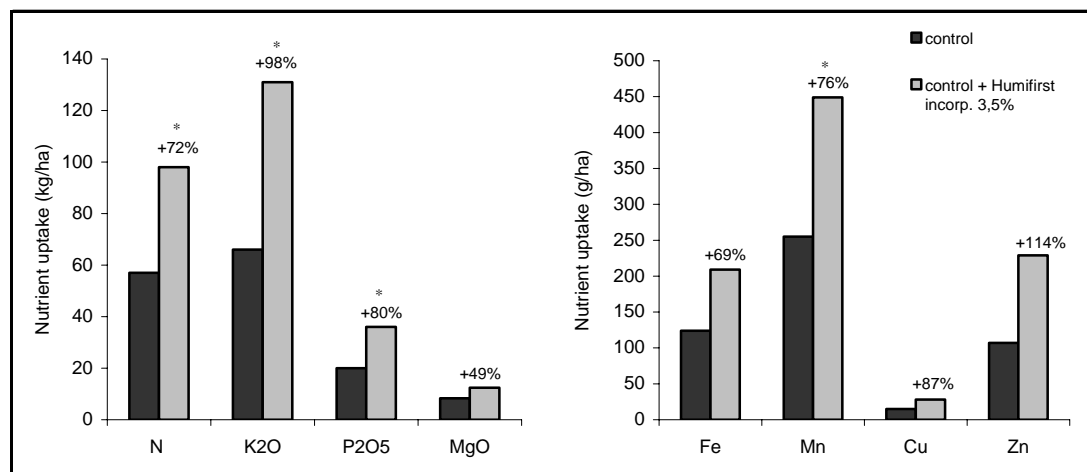

Figure 1 Nutrient uptake of the grass (first grass cut) on the field trial in Hoogstraten  
\* = this result is significant higher than the control ( $\alpha = 0,05$ )

In addition to the higher grass yield with humic acid application at the first grass cut, the *grass quality* was not decreased (Table 2). At the second grass cut, the grass quality was low for both treatments, but due to the lower crude fiber content the digestibility and VEM-value were somewhat better for the humic acid treatment than for the control treatment.

Table 2. Grass quality on the field trial in Bottelare (2006)

	Yield t/ha		Crude protein %		Crude fiber %		Ash % of DM		VEM per kg DM		Digestibility % of OM	
	C	HF	C	HF	C	HF	C	HF	C	HF	C	HF
1st cut	23,8	25,9	16,5	15,6	23,6	22,9	7,9	7,4	1006	1013	83,4	83,6
2nd cut	26,4	25,2	13,6	13,3	30,5	28,0	8,3	8,7	841	888	66,6	72,0

C: control treatment, HF: Humifirst liquid (50 l/ha), VEM: parameter used in Belgium and the Netherlands to indicate net energy lactation (1 liter of milk corresponds with 442 VEM)

For none of the parameters a significant difference between the control and humic acid treatment was noticed ( $\alpha = 0,05$ ).

## Conclusion

In general, application of humic substances in combination with mineral fertilizers or in combination with mineral fertilizers and slurry resulted in a clear yield increase at the first grass cut, with some repercussions in the second or third grass cut. In addition to the higher yields for the first grass cut grass quality was not affected. Nutrient uptake increased in most cases with application of humic acids.

## References

- Burns R., Dell'Agnola G., Miele S, Nardi S, Savoini G, Schnitzer M., Sequi P., Vaughan D and Visser S. (1986) Humic substances, effect on soil and plants. Edited by Reda, Milan. 170pp.
- Vanden Auweele W., Boon W., Bries J., Coppens G., Deckers S., Elsen F., Mertens J., Vandendriessche H., Ver Elst P. and Vogels N. (2004) De chemische bodemvruchtbaarheid van het Belgische akkerbouw- en weilandareaal 2000-2003. Bodemkundige Dienst van België, 138p.

# **Influence of mineral and organic fertilization on the productivity of permanent grassland from forest steppe in the north-eastern part of Romania**

Samuil C.<sup>1</sup>, Vintu V.<sup>1</sup> and Iacob T.<sup>1</sup>

*University of Agricultural Sciences and Veterinary Medicine Iasi, street M. Sadoveanu 3, Iasi 700490, Romania*

## **Abstract**

The permanent pasturelands from Romania measure a 4.934 mil. ha area, from which 340,000 ha are situated in forest and forest steppe zone, on low productive soils, eroded and with an inappropriate botanical composition, leading to small and low quality productions.

This paper presents the results obtained during 1998-2006 on a degraded pastureland with *Festuca valesiaca* L., improved through fertilization with medium doses of mineral and organic fertilizers and through rational use and mowing when the dominant gramineous species start flowering.

The *Festuca valesiaca* L. pasturelands from the Romania's forest steppe react positively at medium organic and mineral fertilization, through the improvement of botanical composition and structure and through the increase of the raw protein content in the fodder.

The best results were obtained at 10 t manure/ha applied associated annually with mineral fertilizers in doses of 50-100 kg N ha<sup>-1</sup>, 25-50 kg P<sub>2</sub>O<sub>5</sub> ha<sup>-1</sup> and 50-100 kg K<sub>2</sub>O ha<sup>-1</sup>.

The doses and the combinations between the fertilizers must be established regarding the economical and organizing possibilities of the beneficiary of the pastoral area and regarding the soil and climatic conditions of the pastureland.

Keywords: degraded pasturelands, organic fertilization, mineral fertilization, improved pastureland

## **Introduction**

Almost 65-70% of the permanent pasturelands from the Moldavian forest-steppe are placed, on slopes and they are damaged by erosion, which diminishes very much their productive potential (Vintu V. *et al.* 2003). The low efficiency of these pasturelands is due to the irrational exploitation, allowing too many animals for grazing on each hectare, and also to the absence of any improving measurements (Carlen C. *et al.* 1998). In many situations, the increase of the productive potential of these pasturelands can be realized through fertilization with different combinations and doses of organic and mineral fertilizers (Cardaşol V., 1994, Jeangros, B. *Et al.* 2003, Ryser J.P. *et al.* 2001, Samuil C. *et al.*, 2004).

In this paper we will present the obtained results during 1998-2006, on a permanent pasture land of *Festuca valesiaca* L., improved by fertilization with different doses and combinations of organic and mineral fertilizers.

## **Materials and methods**

This experiment was conducted on a permanent pastureland of *Festuca valesiaca* L, with a poor botanical composition, placed on a field with a 10% slope. The soil is a cernosium cambic type, lightly washed, with argile type texture and pH 6,5-6,7. The mobile phosphorus content is 25-30 ppm and the mobile potassium content is 300-350 ppm, at a 0-30 cm depth.



In order to improve this pastureland, by fertilization with different doses and combinations of organic and mineral fertilizers, we carried out a monofactorial type experiment, with the following variants: V<sub>1</sub> – unfertilized control; V<sub>2</sub> – 25 kg P<sub>2</sub>O<sub>5</sub> ha<sup>-1</sup> + 50 kg K<sub>2</sub>O ha<sup>-1</sup>; V<sub>3</sub> – 50 kg N ha<sup>-1</sup> + 25 kg P<sub>2</sub>O<sub>5</sub> ha<sup>-1</sup> + 50 kg K<sub>2</sub>O ha<sup>-1</sup>; V<sub>4</sub> – 100 kg N ha<sup>-1</sup> + 50 kg P<sub>2</sub>O<sub>5</sub> ha<sup>-1</sup> + 100 kg K<sub>2</sub>O ha<sup>-1</sup>; V<sub>5</sub> – 10 t ha<sup>-1</sup> manure annually; V<sub>6</sub> – 20 t ha<sup>-1</sup> manure once at two years; V<sub>7</sub> – 40 t ha<sup>-1</sup> manure once at four years; V<sub>8</sub> – 10 t ha<sup>-1</sup> manure + 50 kg N ha<sup>-1</sup> + 25 kg P<sub>2</sub>O<sub>5</sub> ha<sup>-1</sup> + 50 kg K<sub>2</sub>O ha<sup>-1</sup>; V<sub>9</sub> – 10 t ha<sup>-1</sup> manure + 100 kg N ha<sup>-1</sup> + 50 kg P<sub>2</sub>O<sub>5</sub> ha<sup>-1</sup> + 100 kg K<sub>2</sub>O ha<sup>-1</sup>. The manure, phosphorus and potassium were applied in autumn, while the nitrogen was applied in spring, before the beginning of the vegetation period (first decade of April). We harvested when the dominant grasses matured. The production was expressed in dry matter (DM).

## Results and discussion

The data presented in tabel 1 show the positive effect of fertilization on the DM production, with differences related to the applied doses and fertilizer types and to the climatic conditions during the experimentation period.

Table 1. The influence of the fertilization on the dry matter production (t DM ha<sup>-1</sup>)

Fertilization variant	1998-2000		2001-2003		2004-2006		1998-2006	
	t/ha	%	t/ha	%	t/ha	%	t/ha	%
nfertilized control	2.78	100	3.37	100	2.92	100	3.02	100
P <sub>25</sub> K <sub>50</sub>	3.43*	123	5.14**	153	4.97**	170	4.51**	149
N <sub>50</sub> P <sub>25</sub> K <sub>50</sub>	3.95***	142	5.30**	157	5.31***	192	4.85***	161
N <sub>100</sub> P <sub>50</sub> K <sub>100</sub>	4.65***	167	6.60***	196	5.46***	221	5.57***	195
10 t/ha manure annually	4.11***	148	5.68***	169	4.38*	150	4.72**	156
20 t/ha manure once at 2 years	4.46***	160	5.21**	155	5.19***	178	4.95***	164
40 t/ha manure once at 4 years	4.18***	127	5.43**	191	5.45***	187	5.02***	177
10 t/ha manure+ N <sub>50</sub> P <sub>25</sub> K <sub>50</sub>	4.68***	168	6.90***	205	5.24***	179	5.60***	185
10 t/ha manure + N <sub>100</sub> P <sub>50</sub> K <sub>100</sub>	4.94***	178	7.13***	212	5.86***	201	5.98***	198
Average	4.13		5.64		4.97		4.91	
DL 5%	0.55 t ha <sup>-1</sup>		0.75 t ha <sup>-1</sup>		1.27 t ha <sup>-1</sup>		1.04 t ha <sup>-1</sup>	
DL 1%	0.75 t ha <sup>-1</sup>		1.36 t ha <sup>-1</sup>		1.61 t ha <sup>-1</sup>		1.32 t ha <sup>-1</sup>	
DL 0,1%	0.99 t ha <sup>-1</sup>		2.14 t ha <sup>-1</sup>		2.10 t ha <sup>-1</sup>		1.74 t ha <sup>-1</sup>	

From the data obtained during 1998-2006 we can observe that the fertilization can conduct to relatively high productions, in relation with the applied fertilizer's types and doses. No matter the combinations of the applied fertilizers, the best productions were realized at the variants where the highest doses were applied.

The average production during 1998-2006 was of 3.02 t DM ha<sup>-1</sup>, for the unfertilized control and of 4.51-5.57 t DM ha<sup>-1</sup>, in the case of the variants fertilized with mineral compounds, realizing statistically assured increases of 49-95%. In the case of organic fertilized variants, the obtained productions were 4.72-5.02 t DM ha<sup>-1</sup>, realizing increases 56-77%, and for the variants where two combinations of fertilizers were applied the obtained productions were 5.60-5.98 t ha<sup>-1</sup> d.m., realizing increases of 85-98%.

During 1998-2006, the biggest production differences related to the control (tab. 2), were 2.55 t DM ha<sup>-1</sup> in the case of the variants fertilized with mineral compounds (N<sub>100</sub>P<sub>50</sub>K<sub>100</sub>), 2.0 t DM ha<sup>-1</sup> .. for the organic fertilized variants (40 t ha<sup>-1</sup> manure once at 4 years) and 2.96 t DM ha<sup>-1</sup> for the variants where mineral and organic fertilizers combinations were applied (10 t ha<sup>-1</sup> manure + N<sub>100</sub>P<sub>50</sub>K<sub>100</sub>).

The fertilization contributed also to the improvement of the structure of vegetal coverreasing the grass percentage from 56%, for the unfertilized control, at 72% for the fertilization with N<sub>100</sub>P<sub>50</sub>K<sub>100</sub> and 40 t ha<sup>-1</sup> manure once at 4 years, in detriment of other species. The share of the

legumes was between 11%, for the fertilization with N<sub>100</sub>P<sub>50</sub>K<sub>100</sub> and 25% for the fertilization with 20 t ha<sup>-1</sup> manure once in two years (tab. 2). Positive changes were observed in the sward composition as the increase of the participation percentage of some valuable fodder species: *Poa pratensis* L, *Festuca pratensis* Huds, *Arrhenatherum elatius* (L) Presl., *Medicago falcata* L.

Table 2. The evolution of the botanical composition of the sward (%)

Fertilization variant	1998			2006			Deviation		
	G	L	O	G	L	O	G	L	O
Unfertilized control	56	15	29	51	14	35	-5	-1	+6
P <sub>25</sub> K <sub>50</sub>	64	18	18	66	17	17	+2	-1	-1
N <sub>50</sub> P <sub>25</sub> K <sub>50</sub>	68	13	19	69	11	20	+1	-2	+1
N <sub>100</sub> P <sub>50</sub> K <sub>100</sub>	72	11	17	81	10	9	+9	-1	-8
10 t/ha manure annually	71	19	10	69	21	10	-2	+2	0
20 t/ha manure once at 2 years	65	25	10	61	27	12	-4	+2	+2
40 t/ha manure once at 4 years	72	17	11	70	19	11	-2	+2	0
10 t/ha manure + N <sub>50</sub> P <sub>25</sub> K <sub>50</sub>	70	12	18	72	13	15	+2	+1	-3
10 t/ha manure + N <sub>100</sub> P <sub>50</sub> K <sub>100</sub>	69	13	18	75	14	11	+6	+1	-7
Average	67	16	17	68	16	16	+1	0	-1

G – Grass; L – Legumes; O – other species

The changes induced by the fertilization in the floral structure of the sward also influenced the quality of the fodder, inducing a slightly increase of the crude protein percentage, from 6.6% to 7.5% for the fertilization with 10 t ha<sup>-1</sup> manure + N<sub>100</sub>P<sub>50</sub>K<sub>100</sub>, in the same time with a decrease of the crude cellulose percentage from 34.3% for the unfertilized control, to 29.5% for the fertilization with 40 t ha<sup>-1</sup> manure once in 4 years (tab. 3).

Table 3. The influence of fertilization on the fodder's chemical composition (2006)

Fertilization variant	Crude protein	Cellulose	Crude protein production kg/ha
Unfertilized control	6.6	34.3	199
P <sub>25</sub> K <sub>50</sub>	6.8	33.6	307
N <sub>50</sub> P <sub>25</sub> K <sub>50</sub>	6.8	33.8	330
N <sub>100</sub> P <sub>50</sub> K <sub>100</sub>	7.2	33.9	401
10 t/ha manure annually	6.9	33.3	326
20 t/ha manure once at 2 years	7.0	29.8	347
40 t/ha manure once at 4 years	7.0	29.5	351
10 t/ha manure + N <sub>50</sub> P <sub>25</sub> K <sub>50</sub>	7.4	33.4	414
10 t/ha manure + N <sub>100</sub> P <sub>50</sub> K <sub>100</sub>	7.5	33.2	449

The production of Crude protein was between 199 kg ha<sup>-1</sup>, for the unfertilized control, and 449 kg ha<sup>-1</sup>, for the fertilization with 10 t ha<sup>-1</sup> manure+ N<sub>100</sub>P<sub>50</sub>K<sub>100</sub>.

## Conclusions

The average productions during 1998-2006, for the permanent pastureland of *Festuca valesiaca* L. were influenced by the climate conditions, doses and combinations of applied mineral and organic fertilizers, having values between 3.02 and 5.98 t ha<sup>-1</sup>, with realized increases of 49-98%.

The highest average productions were realized during 2001-2003 (5.64 t ha<sup>-1</sup>), due to the higher quantities of rainfall and to the fact that these were much well spread during the whole growing period.

From the obtained data during 1998-2006 we observed that, considering the climate conditions, the fertilization can induce relatively high productions, related to the applied fertilizers doses and types.

The fertilization contributed also to the improvement of the botanical structure by increasing the grass percentage in the detriment of the legumes and other species.

## References

- Cardaşol V. (1994) Fertilization organique des prairies permanentes roumaines; synth de résultats d'essais multilocaux et de longue durée. *Revue Fourrages*, 139, Versailles, France.
- Carlen C., Gex P. and Rölliker R. (1998) Prairie permanente en montagne: effets de l'exploitation sur la qualité du fourrage, le rendement, la composition botanique et la variabilité génétique. *Revue Herba*, 11, 17-23.
- Jeangros, B., Sahli, A. and Jacot, P. (2003) Une fumure organique a-t-elle le meme effet qu'un fumure minérale sur une prairie permanente. *Revue suisse Agric.* 35 (4) 155-160.
- Ryser J.P., Walther U. and Flisch R., (2001) Données de base pour la fumure des grandes cultures et des herbages. *Revue suisse Agric.*, 33 (3), 80.
- Samuil C., Vîntu V., Iacob T. and Postolache Şt., (2004) The role of fertilization and overseeding in improving the productive potential of the degraded permanent pasturelands from the Moldavian forest steppe. *Scientific papers, Agronomical series*, vol. 47. Ion Ionescu de la Brad Press Iaşi. ISSN 1454-7414.
- Vintu V. et al. (2003) Improvement of the degraded rangelands of the Romanian forest steppe by organic and mineral fertilization. *The VII-th International Rangeland Congress*, Durban, South Africa. ISBN 0-958-45348-9, 1267-1269.

# Efficiency of mineral fertilization of legume-grass mixtures under climatic conditions of the Olsztyn Lakeland

Bałuch-Malecka A. and Olszewska M.

*Department of Grassland, UWM Olsztyn, Faculty of Environmental management and Agriculture, 10-718 Olsztyn, Poland*

## Abstract

The experiment was conducted under climatic conditions of the Olsztyn Lakeland (NE Poland), over the years 1998 - 2000. The aim of the study was to determine the efficiency of nitrogen fertilization of legume-grass mixtures, as well as the - protein yield per ha. The yield-forming efficiency of one kg of N was found to depend primarily on legume species in the mixture and experimental period. The highest nitrogen productivity was recorded in the second year. Both legume and grass species in the mixture affected agronomical efficiency. Slightly higher efficiency was observed at lower nitrogen rates. The protein yields attained under weather conditions of the Olsztyn Lakeland were generally high, and ranged from 522 kg ha<sup>-1</sup> in the first year to 3379 kg ha<sup>-1</sup> in the second year. Proper selection of mixture components contributed to high protein yields also in the third year.

Keywords: legume-grass mixtures, mineral fertilization, nutrients

## Introduction

After the withdrawal of animal meals, the improvement of protein balance of feedstuffs is seen only by means of the import of soybean meal, the price of which on world markets is observed to raise systematically. Meanwhile, an alternative – at least to some extent – can be feed mixtures with papilionaceous plants (Zastawny and Jankowska-Huflejt 2003). Nowadays, the role of grasslands in the production of safe and acceptable by consumers food is increasingly appreciated. As claimed by Jakubowski and Czyż (1999), in the rational fertilizer disposal on grasslands high significance is attributed to determination of the fertilization efficiency of nitrogen. Thus, the research undertaken was aimed at comparing the efficiency of mineral fertilization of four legume-grass mixtures under conditions of the Olsztyn Lake District as well as at determining which of the mixtures proposed would provide the highest protein yield.

## Materials and methods

The study was based on a three-year, two-variable field experiment established on the 12th of May 1998 at the Research Station in Tomaszkowo with the method of randomized blocks in 4 replications. Topsoil was characterized by a high content of available iron and manganese, a medium content of phosphorus and potassium as well as by a low concentration of - sodium, magnesium, zinc and copper. Humus content reached 1.58 %. Soil pH was basic (pH<sub>KCl</sub>- 7.3). The size area of a plot for harvest was 10 m<sup>2</sup>. The first experimental variable were 4 legume-grass mixtures (sown at a ratio of: 50 % a papilionaceous plant to 50 % of grassa):

- *Trifolium pratense* L. cv. Ulka with *Festuca pratensis* Huds. cv. Skrzyszowicka (Tp+Fp),
- *Lotus corniculatus* L. cv. Skrzyszowicka with *Dactylis glomerata* L. cv. Bepro (Lc+Dg),
- *Trifolium repens* L. cv. Astra with *Lolium perenne* L. cv. Anna (Tr+Lp),
- *Medicago lupulina* L. cv. Renata with *Festuca rubra* L. cv. Nakielska (Ml+Fr).

The second experimental variable was differentiated mineral fertilization: 1- control-  $N_0$ ,  $P_0$ ,  $K_0$  kg ha<sup>-1</sup>; 2-  $N_0$ ,  $P_{35}$ ,  $K_{100}$  kg ha<sup>-1</sup>; 3-  $N_{60}$ ,  $P_{35}$ ,  $K_{100}$  kg ha<sup>-1</sup>; and 4-  $N_{120}$ ,  $P_{35}$ ,  $K_{100}$  kg ha<sup>-1</sup>. Nitrogenous fertilizers were applied in the form of ammonium nitrate:  $N_{60}$  kg ha<sup>-1</sup> - 20 kg in the springtime, 20 kg after the harvest of I swath, 20 kg after harvest of II swath and  $N_{120}$  kg ha<sup>-1</sup> - 40 kg in the springtime, 40 kg after the harvest of I swath, 40 kg after the harvest of II swath. Phosphatic fertilizers were applied once in the springtime in the form of triple superphosphate, whereas potassium fertilizers – in two equal doses in the springtime and after the harvest of the first cut. At the harvest of forage, two 1-kg samples were collected that were later used for determination of dry mass content, species composition of sward and for chemical analyses. Nitrogen was assayed with the method of Kjeldahl. Protein yield was calculated as a quotient of dry matter yield to total protein ( $N \times 6.25$ ). Results obtained were elaborated statistically with the use of Statistica software.

Particular experimental years differed in terms of the course of weather conditions. Air temperatures in the periods since April till September were higher than the long-term means. High temperatures were recorded especially in April, May and June of 1998, June and July of 1999 as well as April, May and June of 2000. Precipitations were not evenly distributed in particular years of the study. Deficiency of precipitation in the year of experiment establishing was noted in July, especially in the first decade. In 1998, the sum of precipitation in the vegetative season was lower by 16.1 mm from the long-term mean, whereas in the period since April till July of 1999 the rainfalls were recorded at a level of 288.6 mm as compared to 166.1 mm noted for the long-term mean. The sum of precipitations in the vegetative season of 2000 (367 mm) was again lower (by 4.2 mm) than the long-term means (371.2 mm).

## Results and discussion

The agronomic efficiency expressed by an increase in the yield of dry mass of the mixtures examined, as a mean of the three experimental years, fluctuated from 3.7 kg DM to 18.8 kg DM ha<sup>-1</sup> (Table 1).

Table 1. Agronomic efficiency of nitrogen (kg DM ha<sup>-1</sup>).

	1998		1999		2000		Mean of the years 1998-2000	
	$N_{60}$	$N_{120}$	$N_{60}$	$N_{120}$	$N_{60}$	$N_{120}$	$N_{60}$	$N_{120}$
Tp+Fp	17.0	7.5	2.3	2.8	13.3	10.4	10.9	6.9
Lc+Dg	-2.5	7.1	21.5	17.1	-8.0	2.8	3.7	9.0
Tr+Lp	23.8	3.6	35.0	37.5	7.3	10.8	22.0	17.3
MI+Fr	-1.7	1.5	41.7	34.9	16.3	14.0	18.8	16.8
Mean	9.2	4.9	25.1	23.1	7.2	9.5	13.8	12.5

The highest efficiency, i.e. 41.7 kg DM, was reported in the second year of the study in plots with a mixture of *Medicago lupulina* and *Festuca rubra*, and the lowest one, i.e. -8.0 kg DM, in the third year in plots with a mixture of *Lotus corniculatus* and *Dactylis glomerata*. The research indicated vast differences in the agronomic efficiency of nitrogen in particular mixtures depending on the year of the study. They were mainly due to changes in the content of papilionaceous plants in the sward and the course of weather conditions. Kryszak (2003) emphasizes that the low nitrogen efficiency in legume-grass mixtures is likely to result from a considerable share of legumes in the sward as well as from beneficial soil conditions. Boller (1988) demonstrated that at a high content (ca. 70%) of common clover in the mixture and concomitant fertilization with nitrogen the activity of binding atmospheric nitrogen decreases, which may even decrease the yield. The agronomic efficiency of 60 kg nitrogen ha<sup>-1</sup> applied in the reported study ranged, on average, from 7.2 kg DM ha<sup>-1</sup> in the third year to 24.1 kg DM ha<sup>-1</sup> in the second year of cultivation. The application of a higher nitrogen dose only in the

third year caused an increase in dry mass yield by 2.3 kg ha<sup>-1</sup>, taking into account the mean of all mixtures. Frame (1992) emphasizes that an efficient dose of nitrogen should be high enough to yield at least 7.5 kg of dry mass per kilo of fertilizing nitrogen. In a study by Kryszak (2003), the efficiency of fertilization with a dose of 150 kg N ha<sup>-1</sup> for a tetraploid mixture of common clover with perennial ryegrass in the first year of the study reached 21 kg DM per kg of nitrogen applied. In our experiment, taking into account mean values of the three experimental years, the efficiency obtained at the lowest dose of nitrogen was higher by 1.3 kg DM ha<sup>-1</sup> as compared to the dose of 120 kg N ha<sup>-1</sup>. Only in one mixture, i.e. *Lotus corniculatus* with *Dactylis glomerata*, was the efficiency higher by 5.3 kg DM ha<sup>-1</sup> at a higher nitrogen dose. It results from an increased content of nitrophilous orchard grass in the sward. Grzegorzczuk and Olszewska (1997) emphasize that the higher fertilization efficiency of legume-grass mixtures results, to a great extent, from increased content of grasses in the sward at the expense of the papilionaceous plants. Jelinowska (1985) points to the fact that orchard grass demonstrates an increased yield at nitrogen doses reaching even up to 840 kg ha<sup>-1</sup> annually. In addition, she emphasized that the efficiency of 1 kg N administered on grasses is high and ranges from 22 to 30 kg DM. In evaluating nitrogen fertilization applied in the mixtures examined, vast differences were observed in experimental years. It results, probably, from the course of meteorological conditions over the experimental period. In the study of Jakubowski and Czyż (1999), in the years of reduced precipitation the utilization of nitrogen was lower than in the humid year. In addition, they emphasize that nitrogen fertilization applied under favorable conditions of soil moisture content contributes to a considerable yield increase. In our study, the highest efficiency was obtained in the year 1999, in which precipitations reported were higher than the long-term mean. In all experimental years, significantly the highest protein yield irrespective of fertilization level was obtained in plots with the mixture of *Trifolium pratense* and *Festuca pratensis* (Table 2).

Table 2. Protein yield (kg DM ha<sup>-1</sup>)

	Tp+Fp	Lc+Dg	Tr+Lp	MI+Fr	Mean
1998 year					Mean
N <sub>0</sub> P <sub>0</sub> K <sub>0</sub>	1460 cd	624 a	1394 bcd	1359 bc	1209 a
N <sub>0</sub> P <sub>35</sub> K <sub>100</sub>	1464 cd	656 a	1384 bc	1704 e	1302 b
N <sub>60</sub> P <sub>35</sub> K <sub>100</sub>	1650 e	522 a	1338 bc	1559 de	1267 ab
N <sub>120</sub> P <sub>35</sub> K <sub>100</sub>	1670 e	649 a	1285 b	1426 bcd	1257 ab
Mean	1561 c	613 a	1350 b	1512 c	1259
1999 year					Mean
N <sub>0</sub> P <sub>0</sub> K <sub>0</sub>	2950 g	1765 cd	2035 f	1292 b	2010 a
N <sub>0</sub> P <sub>35</sub> K <sub>100</sub>	3318 h	1811 cde	1964 ef	1197 ab	2073 a
N <sub>60</sub> P <sub>35</sub> K <sub>100</sub>	3343 h	1727 c	1932 def	1056 a	2015 a
N <sub>120</sub> P <sub>35</sub> K <sub>100</sub>	3379 h	1649 c	2055 f	1259 b	2085 a
Mean	3247 d	1738 b	1996 c	1201 a	2046
2000 year					Mean
N <sub>0</sub> P <sub>0</sub> K <sub>0</sub>	3027 fg	1806 e	1459 ab	1499 bc	1948 a
N <sub>0</sub> P <sub>35</sub> K <sub>100</sub>	2952 f	1812 e	1847 e	1756 de	2092 b
N <sub>60</sub> P <sub>35</sub> K <sub>100</sub>	3065 fg	1454 ab	1569 bcd	1427 ab	1879 a
N <sub>120</sub> P <sub>35</sub> K <sub>100</sub>	3224 h	1377 ab	1377 cde	1272 a	1883 a
Mean	3067 c	1613 b	1633 b	1488 a	1951

a, b, c- homogenous groups, P=0.05

statistical analyses were carried out separately for the means of mixtures and these of fertilization (NIR test)

In the first experimental year, alike yield was observed for the mixture of *Medicago lupulina* and *Festuca rubra*, and significantly the lowest yield – for the mixture of *Lotus corniculatus* and *Dactylis glomerata*. In turn, in the second and third year of the study, significantly the

lowest yields of protein were obtained on plots with the mixture of *Medicago lupulina* and *Festuca rubra*. Over the three experimental years, high yields were recorded on plots with the mixture of *Trifolium repens* and *Lolium perenne*. This has also been confirmed in a study by Dembek (1999). Taking into account the effect of mineral fertilization on protein yields, significantly the highest yields were observed in the first and third year of the study at the null dose of nitrogen and phosphorus-potassium fertilization. The results obtained in our study correspond with findings of Wolski (1998). In contrast, in the research by Kitczak (1997) increased nitrogen fertilization from 150 to 300 kg ha<sup>-1</sup> of a *Medicago sativa* and *Bromus unioloides* mixture evoked a significant increase in the yield of dry mass – by 20% and in that of total protein – by 29%. That author, however, points to the fact that the higher efficiency of fertilization with a dose of 300 kg N ha<sup>-1</sup> can be obtained under conditions of optimal water supply of the crop, e.g. through complementary irrigation.

## Conclusion

Under conditions of the Olsztyn Lake District, the agronomic efficiency of nitrogen was higher at a lower nitrogen dose and depended, to a great extent, on the species composition of the mixtures examined as well as on the experimental year. Appropriate selection of components of mixtures facilitated obtaining high protein yields. Considering the effect of mineral fertilization on protein yield, the most efficient appeared to be the null dose of nitrogen. The most important factor in the process of deintensification of feedstuff production appears to be the proper selection of species and cultivars of plants for habitat conditions which enables obtaining quantitatively and qualitatively satisfactory yields at the lowest inputs incurred on their acquisition.

## References

- Boller B. (1988) Biologische Stickstoff-Fixierung von Weis – und Rotklee unter Feldbedingungen. Landwirtschaft Schweiz 1(4), 251-253.
- Grzegorzczak S. and Olszewska M. (1997) Rośliny motylkowate w mieszankach z trawami jako czynnik ograniczający nawożenie azotowe. Zesz. Probl. Post. Nauk Rol., z. 453, 209-215.
- Dembek R. (1999) Ocena wiązania azotu przez koniczynę białą w siewach jednogatunkowych i mieszankach z życią trwałą. Zesz. Probl. Post. Nauk Rol., z. 453, 357-364.
- Frame J. (1992) Improved Grassland Management, Framing Press Books, Ipswich, UK, 351 pp.
- Jakubowski P. and Czyż H. (1999) Wpływ nawożenia wermikompostem na bilans oraz wykorzystanie azotu na łące wiechlinowej. Grassland Science in Poland, 2, 59-65.
- Jelinowska A. (1985) Produkcja pasz z połowych zasiewów traw w świetle wyników doświadczeń polskich. Zesz. Probl. Post. Nauk Rol., z. 293, 29-39.
- Kitczak T. (1997) Plonowanie lucerny siewnej (*Medicago sativa* L.) i stokłosa obiedkowej (*Bromus unioloides* Humb. et Kunth.) w siewie czystym i mieszanym w warunkach zróżnicowanego nawożenia azotowego i nawadniania. Biul. Oceny Odm., 29, 167-172.
- Kryszak J. (2003) Wartość gospodarcza mieszanek motylkowato-trawiastych w uprawie polowej. Roczn. AR Poznań Rozprawy naukowe, 338, 108 pp.
- Wolski K. (1998) Wpływ koniczyny łąkowej na plon, wartość energetyczną i masę białka ogólnego. Biul. Nauk., Nr 1, ART Olsztyn, 439-445.
- Zastawny J. and Jankowska-Huflejt H. (2003) Znaczenie pasz z użytków zielonych na tle współczesnych zagrożeń jakości zdrowotnej środków żywienia zwierząt i ludzi. Zasady produkcji i wykorzystania pasz łąkowo-pastwiskowych jako bezpiecznego ogniwa w łańcuchu pokarmowym. Falenty, Wydaw. IMUZ, 7-13.

# Pasture production in silvopastoral systems of NW Spain receiving sewage sludge or mineral fertilizer

López-Díaz M.L.<sup>1</sup>, Rigueiro-Rodríguez A.<sup>2</sup> and Mosquera-Losada M.R.<sup>2</sup>

<sup>1</sup>*Dpto Biología y Producción de los Vegetales, Centro Universitario de Plasencia, Univ. Extremadura, Avda. Virgen del Puerto, nº2, 10600 Plasencia-Cáceres (Spain)*

<sup>2</sup>*Dpto. Producción Vegetal, EPS Lugo, Univ. Santiago de Compostela, (Spain)*

## Abstract

In recent years, the European regulation about residual waste water implementation has produced an important increase in sewage sludge production in EU countries and a reduction in the usual methods of disposal which produced environmental problems. The use of sewage sludge as fertilizer that is regulated by European Directive 86/278, is being studied in different countries of Europe, because of its nutrient content, especially nitrogen, but always regarding the higher heavy metal levels than in soil. The objective of this experiment was to test the effect of sewage sludge and mineral fertilization on production of pasture developed under *Pinus radiata* during three years. The experiment was located in Lugo (NW Spain) on land abandoned from agriculture. In autumn 1997, a pasture mixture was sown (*Lolium perenne*, *Dactylis glomerata* and *Trifolium repens*). In winter 1997, a *Pinus radiata* plantation was established (density 1667 trees/ha) over the pasture. Fertilization treatments were applied during three years. Pasture production was highest in the second year due to climatic conditions. Since 1999, results obtained with organic and inorganic fertilization were similar.

Key words: sewage sludge, *Dactylis glomerata*, *Lolium perenne*, *Trifolium repens*.

## Introduction

In silvopastoral systems, tree, forage and livestock production are integrated into a farm management programme designed to simultaneously provide woody-plant commodities. Therefore, the farmer is able to generate income from the sheep, cattle or other stock, as the trees continue to grow in the pasture (Nair and Graetz, 2004). At the same time, grazing prevents accumulation of understorey woody plants and its associated fire risk, which is one of the more important environmental problems in forests in North Spain (Rigueiro-Rodríguez *et al.*, 2005). In September 2005, a Council Regulation on Support for Rural Development was published by the European Agriculture Fund for Rural Development (2005), which establishes that “measures targeting the sustainable use of forestry land through the first establishment of agroforestry systems on agricultural land” should be taken.

Spain has a temperate climate, with two different contrasting temperate and precipitation regimes, Atlantic and Mediterranean. Atlantic Spanish regions were dramatically deforested for centuries and an important effort was made during the last century to afforest mountain and agricultural land, mainly with fast-growing species, like *Pinus radiata*, *Pinus pinaster* and *Eucalyptus globulus*. *Pinus radiata* is a tree species which integrates well into silvopastoral systems in the humid area of Spain (Rigueiro-Rodríguez *et al.*, 2005). Galician soils are acidic, with low production and nutritive value of herbage due to soil factors. Increased total nutrient availability normally results in increased herbage production and nutritive value (Stevens and Laughlin, 1996). Applications of fertilizer to silvopastoral systems have been shown to increase both pasture and tree growth without harmful effects on trees (Sinclair *et al.*, 2000). Fertilizer can be applied as inorganic and organic fertilizer but the



effects of organic fertilizer on pasture production have been less extensively evaluated than the effects of inorganic fertilizer. There is little information on how sewage sludge inputs affect soil nutrient availability. Since the 1990s the implementation of the European Union (EU) Directive 91/271/CEE (European Commission, 1991) has led to a marked increase in sewage sludge production in EU countries. Studies in several European countries on the use of sewage sludge as a fertilizer, which is regulated by EU Directive 86/278/CEE (European Commission, 1986), have concluded that sewage sludge is a good fertilizer due to its high content of macronutrients, particularly N, and to a lesser extent of P, K, Ca and Mg. However, the use of sewage sludge also has to take into account the higher proportion of heavy metals in the sludge than in the soil, as these are toxic elements that can enter the food chain constituting a health risk (Smith, 1996).

## Materials and methods

The experiment was conducted in agricultural land at Lugo, in the north-west of Spain, at an altitude of 450 m and with a mean annual precipitation over 1000 mm. A pasture mixture was sown (25 kg ha<sup>-1</sup> *Lolium perenne* cv 'Brigantia', 10 kg ha<sup>-1</sup> *Dactylis glomerata* cv 'Artabro', 4 kg ha<sup>-1</sup> *Trifolium repens* cv 'Huia') in Autumn 1997. The experiment was on a sandy soil with a pH of 6.3, 31.5 g kg<sup>-1</sup> of N, a high available-phosphorus status (0.03 g kg<sup>-1</sup>) and a medium available-potassium status (K<sub>2</sub>O: 0.09 g kg<sup>-1</sup>). In January 1998, a plantation of *Pinus radiata* was established at a density of 1667 trees ha<sup>-1</sup>. Three treatments were applied following a randomised block design with three replicates. Treatments consisted of no-fertilization (NF), sewage sludge application (160 kg N total ha<sup>-1</sup>) and the inorganic fertilization usually used in the region (MIN: 80 kg N ha<sup>-1</sup>, 120 kg P<sub>2</sub>O<sub>5</sub> ha<sup>-1</sup> and 200 kg K<sub>2</sub>O ha<sup>-1</sup>). Heavy metal concentrations in soil and sewage sludge on the trial site were below the legal limits for using sewage sludge as fertiliser in the European Union (Directive 86/278/EEC) and in Spain (R.D. 1310/1990). These treatments were surface applied homogenously in the spring of 1998, 1999 and 2000, in plots of 24 m<sup>2</sup>. The sewage sludge application was based on total N (3.21, 3.21 and 4.23 % in 1998, 1999 and 2000, respectively) and mineral N concentrations in line with Environment Protection Agency recommendations (EPA, 1994), which assume that around 0.25 of total nitrogen applied with anaerobic-digested sewage sludge will be mineralized in the first year (Serna and Pomares, 1992). Plots were harvested twelve times during the experiment, in May, June, July and November in 1998, 1999 and 2000 3 years\*4 occasions = 12???. Before harvesting, four herbage samples (each of 0.09 m<sup>2</sup>) were taken from each plot using hand clippers at a height of 2.5 cm. Herbage samples were dried in an oven at 80°C for 48 h and annual pasture production was determined. Data were analysed as randomized block design with NPK treatments as the main factors by ANOVA with Duncan tests for pairwise comparison of means. All analyses were performed with the SAS package (SAS, 2001).

## Results and discussion

Annual pasture production with the different fertilization treatments in 1998, 1999 and 2000 can be observed in Figure 1. In most cases, these values were similar to those observed by Mosquera-Losada and González-Rodríguez (1999) in Galicia (6-12 t DM ha<sup>-1</sup>). In 1999, they were higher than those detected by these authors when organic or mineral fertilization was applied because the soil was more fertile. Significant differences ( $P=0.0001$ ) were detected between years. The highest level of pasture production was found in 1999 (11.29-13.69 t DM ha<sup>-1</sup>) and the lowest values were in 2000 (7.60-8.90 t DM ha<sup>-1</sup>). Variability in pasture production may depend on the specific weather conditions of the year of measurement, and is mainly explained by variability in summer precipitation (Mosquera-Losada and González-

Rodríguez, 1999). The high precipitation found in summer 1999 (320 mm) increased the growth period and, therefore, annual pasture production. However, summer drought in 2000 (144 mm) could explain the lower production in 2000 compared to the other years. Moreover, the productivity reduction in the last year could be caused by the competition between trees and pasture, as tree height and diameter were around 148-175 cm and basal diameter was 4.19-5.17 cm. During all the experiment, pasture production was significantly modified by fertilizer treatments. In 1998, pasture production was significantly increased by mineral fertilization (10.75 t DM ha<sup>-1</sup> compared to 9.24 and 9.48 t DM ha<sup>-1</sup> with no-fertilization and sewage sludge, respectively). But, since 1999, sewage sludge application (S) produced similar results (13.33 and 8.48 t DM ha<sup>-1</sup> in 1999 and 2000, respectively) to inorganic fertilization (13.69 and 8.90 t DM ha<sup>-1</sup> in 1999 and 2000, respectively) and, in 1999, than in no-fertilization (11.28 t DM ha<sup>-1</sup>). Positive effects of sewage sludge fertilization on pasture production in forest soils were found by different authors (e.g. Mosquera-Losada *et al.*, 2001, Lopez-Díaz *et al.*, 2007) in Spain when grasses are the dominant species in the pasture. However, in more fertile agricultural soils, the response depended on the effect of nitrogen fertilization on white clover. If the P and K soil content is adequate to allow white clover growth, *Rhizobium* nitrogen fixation can mask a positive fertilization effect on pasture production (Green *et al.*, 1999). This could explain the high pasture production with no-fertilization, that contained about 29% of *Trifolium repens* in June 2000, but there was also substantial quantities of *Trifolium repens* with organic and inorganic fertilization, with percentages about 25% and 14% of white clover respectively. In this experiment, the increment in pasture production was between 2%, 18% and 11% with sewage sludge and 16%, 21% and 17% with mineral fertilizer in 1998, 1999 and 2000, respectively. It is important to take into account that 25%, 12.5% and 7.5% of sewage sludge total N is mineralized in the first, second and third year after application (Serna and Pomares, 1992; EPA 1994). When this pattern is considered the predicted quantity of mineralized N provided by sewage sludge treatment was 80, 104 and 114.5 kg N ha<sup>-1</sup> in 1998, 1999 and 2000. This increase in mineralized N brought by organic fertilization could explain the improvement of pasture production with sewage sludge in the second and third year compared with the first year. In a silvopastoral system, in forest soils very acidic with similar fertilization treatments, Rigueiro-Rodríguez *et al.* (2007) showed that the increase of pasture production caused by sewage sludge compared with no fertilization was higher (40 and 35% the first two years) than in the present experiments.

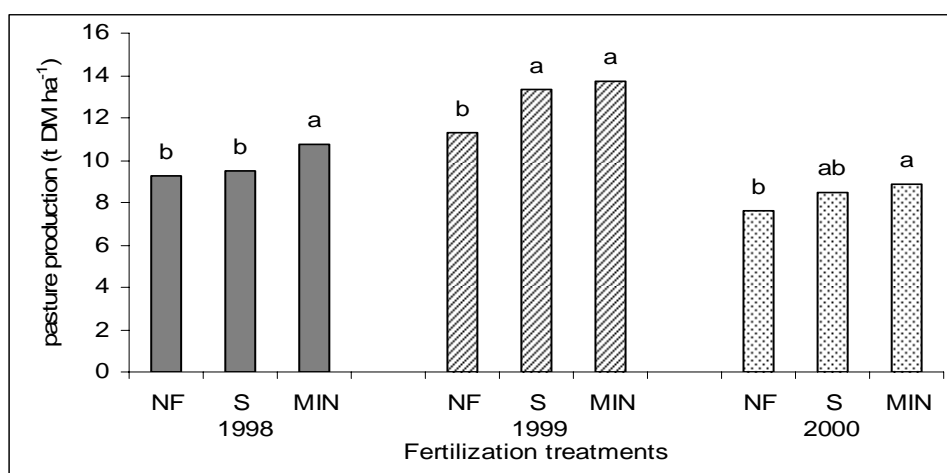

Figure 1.- Annual pasture production (t DM ha<sup>-1</sup>) with different fertilization treatments in 1998, 1999 and 2000. NF: no fertilization; S: sewage sludge (320 kg total N ha<sup>-1</sup>); MIN: mineral fertilization (80 kg N ha<sup>-1</sup>). Different letters indicate significant differences between fertilization treatments (P<0.05).

However, in other experiments the response of pasture production to fertilization has been limited by shade caused by trees (*Pinus radiata*, 8 years old) (Balocchi and Philips, 1997) and by mineralization speed (López-Díaz *et al.*, 2007). Moreover, in that experiment, mineral fertilization produced similar results to no-fertilization and significantly worse than organic fertilization, due to MIN increasing soil acidity and Al saturation in the interchange complex (López-Díaz *et al.*, 2007).

## Conclusions

Variability in pasture production may depend on the specific weather conditions of the year of measurement. During all the experiment, mineral fertilization improved pasture production respect to no-fertilization. Since 1999, the second year of the experiment, results obtained with organic and inorganic fertilization were similar.

## Acknowledgements

We are grateful to CICYT and XUNTA DE GALICIA for financial assistance; to Divina Vázquez Varela, Teresa Piñeiro López and José Javier Santiago-Freijanes for helping in processing, laboratory and field.

## References

- Balocchi O.A. and Phillips C.J.C. (1997) Grazing and fertiliser management for establishment of *Lotus uliginosus* and *Trifolium subterraneum* under *Pinus radiata* in southern Chile. *Agroforestry systems*, 37, 1-14.
- BOE (1990) Decree 1310/1990 of 29<sup>th</sup> October 1990 that regulates the use of sewage sludge. Madrid, Spain. Ministerio Agricultura, Pesca y Alimentación.
- Campbell C.D., Atkinson D., Jarvis P.G. and Newbould P. (1994) Effects of nitrogen fertiliser on tree/pasture competition during the establishment phase of a silvopastoral system. *Ann. Appl. Bio.*, 124, 83-96.
- Green J.J., Alifragis D., Baddeley J.A., Bagnaresi U., Bohne H. and Bulfin M. (1999) Impact of understorey vegetation on tree production in European agroforestry systems. In: Papanastasis V.P, Frame J. and Nastis A.S. (eds.). *Grassland and woody plants in Europe*, 171-176.
- Environment Protection Agency (1994) Land Application of Sewage Sludge. A Guide for Land Appliers on the Requirements of the Federal Standards for the Use of Disposal of Sewage Sludge, 40 CFR Part 503.
- López-Díaz M.L., Mosquera-Losada M.R. and Rigueiro-Rodríguez A. (2007) Lime, sewage sludge and mineral fertilization in a silvopastoral system developed in very acid soils. *Agroforestry systems* (in press).
- Mosquera M.R. and González A. (1999) Pasture production in Northern Spain dairy system. *New Zealand Journal of Agricultural Research*, 42, 125-132.
- Mosquera-Losada M.R., Rigueiro-Rodríguez A. and López-Díaz M.L. (2001) Sewage sludge fertilization of a silvopastoral system with pines in north-western Spain. *Agroforestry Systems*, 53, 1-10.
- Nair V.D. and Graetz D.A. (2004) Agroforestry as an approach to minimizing nutrient loss from heavily fertilized soils: The Florida experience. *Agroforestry Systems*, 61, 269-279.
- Rigueiro-Rodríguez A., Mosquera-Losada M.R., Romero-Franco R., González-Rodríguez M.P. and Villarino-Urtiaga J.J. (2005) Silvopastoral systems as a forest fire prevention technique. In: Mosquera-Losada MR, McAdam J, Rigueiro-Rodríguez A. (eds) *Silvopastoralism and Sustainable Land Management*, CABI Publishing, 380-387.
- Rigueiro-Rodríguez A., Mosquera-Losada M.R. and López-Díaz M.L. (2007) Soil and Forage N, P, K, Ca and Mg concentrations in a *Pinus radiata* silvopastoral system in North West Spain after sewage sludge and lime application. *Grass and Forage* 62 (in press).
- SAS (2001) User's Guide, Statistics. SAS Institute Inc. Cary NC.
- Serna M.D and Pomares F. (1992) Nitrogen mineralization of sludge-amended soil. *Bioresource technology*, 39(3), 285-290.
- Smith S.R. (1996) *Agricultural recycling of sewage sludge and the environment*. CAB International.
- Stevens R.J. and Laughlin R.J. (1996) Effects of lime and nitrogen fertilizer on two sward types over a 10-year period. *Journal of Agricultural Science*, 127, 451-461.

## Forage yield and quality potential of different white clover forms

Butkutė B., Paplauskienė V. and Sprainaitis A.

*Lithuanian Institute of Agriculture, LT-58344 Akademija, Kedainiai distr., Lithuania*

### Abstract

The objective was to evaluate accessions of white clover (*Trifolium repens* L.) forms *hollandicum*, *giganteum*, *hollandicum x giganteum* and *silvestre* for herbage yield, quality and bio-morphological properties. White clover varied with and within forms according to their morphological structure and biological properties: winter damage, time of flowering, profuseness of flowers, height of plants and other. Among the white clover forms, accessions of *hollandicum x giganteum* and *giganteum* produced the highest herbage DM yield. Data suggest that clover forms only slightly differed in the composition of the main components defining feeding value of herbage. Varieties and breeding lines differed more according to the concentration of toxic compounds - cyanogenic glycosides (HCN). The averaged data suggest that the accessions of *silvestre* form had the lowest concentration of HCN in herbage (281 mg kg<sup>-1</sup>), while those of *giganteum* - had the highest content (380 mg kg<sup>-1</sup>). Relationships between the values of herbage quality components and some bio-morphological properties were calculated. Concentrations of HCN correlated positively with plant winter damage, DM digestibility (DMD) - with time of flowering, modified acid detergent fibre (MADF) - with profuseness of flowers.

Keywords: white clover, forms, morphological traits, quality parameters

### Introduction

Emphasis on environmentally sustainable development with the use of renewable resources moves us to pay special attention to decrease amounts of N fertilisers through the biological nitrogen fixation. White clover (*Trifolium repens* L.) is one of the most important legume components in pastures of the 250-300 species in the genus *Trifolium* and can contribute significantly to N fixation in a sward. The interest in incorporation of clovers in the nutrition chain of animals is based on their good feeding value: white clover, in comparison with grasses, contains more protein, ash, less fibre and is characterised by higher intake (Dewhurst *et al.*, 2003), though poisonous compounds - cyanogenic glycosides are commonly found in *T. repens*. White clover populations exhibit high genetic and clonal diversity (Gustine and Elwinger, 2003). Accessions differ in both morphological and physiological properties and they are classified arbitrarily according to plant size (Sareen, 2003; Sprainaitis, Paplauskienė, 2002). The selection of varieties for hay and pasture is an important decision requiring knowledge of both agronomic characteristics and potential feeding value of forage plants.

### Materials and methods

The genetic collection of white clover of the Lithuanian Institute of Agriculture (LIA) including varieties, wild populations and breeding lines was assessed for quality over the period 2003-2006 on a sod gleyic, medium heavy, drained loam soil with a pH value in the arable layer varying from 6.4 to 7.2 and a humus content from 19 to 22 g kg<sup>-1</sup>. The white clover populations were sown on 10.0–12.5 m<sup>-2</sup> plots in the first half of June without a cover crop. The clover was tested for morphological or biological traits according to standard

methods (IPGRI, 1992; UPOV, 1985). The assessment is based on a 1-9 or a 3-7 point system, 1-3 being very low and low value of the trait, 5-medium, 7-9-high and very high value of the character. For chemical analyses composite samples were formed at grass heading stage of the first cut. Dried and ground by a mill with 1 mm sieve samples were analysed for crude protein (CP), modified acid detergent fibre (MADF), pepsine-cellulase DM digestibility (DMD) and water soluble carbohydrates (WSC) by near infrared spectroscopy and for cyanogenic glucosides (HCN) by mercurimetric method.

## Results and discussion

Study results revealed that white clover forms differed more in DM yield than in quality, and that there existed a variation within each form. The statistical mean over four years, range of values and coefficient of variation (CV%) of dry matter yield and concentrations of quality components in herbage DM of white clover forms are presented in Table 1. According to averaged data clover forms differed slightly in the composition of the main components defining feeding value, i.e. CP, MADF, WSC and DMD. The WSC concentration was found to be the most variable parameter among the rehearsed ones: the variation coefficient was as high as 12.22- 18.97 %.

Table 1. Mean and variation of herbage dry matter yield and quality of white clover forms, 2003-2006.

Indicator of Quality	Statistics	Systematic form			
		<i>hollandicum</i> n=16	<i>giganteum</i> n=12	<i>hollandicum x giganteum</i> n=12	<i>silvestre</i> n=19
Crude protein (CP)	Mean g kg <sup>-1</sup>	208	206	209	212
	Range g kg <sup>-1</sup>	182- 260	178-257	188-261	188-258
	Variation coefficient CV %	10.30	10.83	11.88	11.08
Modified acid detergent fibre (MADF)	Mean g kg <sup>-1</sup>	190	192	189	190
	Range g kg <sup>-1</sup>	164-227	175-216	167-216	161-218
	Variation coefficient CV %	9.77	6.42	9.14	10.06
Dry matter digestibility (DMD)	Mean g kg <sup>-1</sup>	849	843	849	845
	Range g kg <sup>-1</sup>	788- 904	789-871	809-902	797-908
	Variation coefficient CV %	4.21	2.80	3.57	3.70
Water soluble carbohydrates (WSC)	Mean g kg <sup>-1</sup>	167	170	165	156
	Range g kg <sup>-1</sup>	131-200	119-199	116-216	87-185
	Variation coefficient CV %	12.22	15.19	16.46	18.97
Cyanogenic glycosides (HCN)	Mean g kg <sup>-1</sup>	341	380	301	281
	Range g kg <sup>-1</sup>	154-819	220-539	224-457	143-550
	Variation coefficient CV %	54.94	37.17	36.07	43.89
Dry matter (DM) yield	Mean t ha <sup>-1</sup>	7.07	8.07	7.66	6.65
	Range t ha <sup>-1</sup>	6.13- 7.63	7.03-9.04	7.10-8.54	5.74-7.82
	Variation coefficient CV %	7.14	6.68	5.50	11.29

The herbage of the first cut of all white clover varieties tested contained quite high concentrations of CP (178-261 g kg<sup>-1</sup>) and were characterised by good DMD (788-908 g kg<sup>-1</sup>), but some varieties accumulated high contents of harmful substances - cyanogenic glycosides (HCN). The variation coefficient of HCN content ranged from 36.07% for *hollandicum x*

*giganteum* to 54.94% for *hollandicum* accessions. Averaged data indicate that the lowest content of HCN was accumulated by the individuals of *silvestre* form (281 g kg<sup>-1</sup>), the highest - by those of *giganteum* form (380 g kg<sup>-1</sup>). The concentration of these compounds depended not only on the variety and ecotype but also on the cut and varied in separate individuals of the variety or ecotype (Paplauskiene and Butkute, 2006). Large-leafed *giganteum* form was characterised by the highest DM yield of two cuts with mean 8.07 t ha<sup>-1</sup> and a range 7.03-9.04 t ha<sup>-1</sup>. Accessions of *silvestre* were noted for the lowest average DM yield and in individual samples it ranged from 5.74 to 7.82 t ha<sup>-1</sup>. The medium leaf-sized *hollandicum* form of white clover is most common in Lithuania. It is less-yielding, with a lower competitive power; however, it is noted for higher growth rate, profuseness of flowers and higher seed set than *giganteum* (Table 2).

Table 2. Mean and range of points of morphological attributes and biological traits in the forms of white clover. Assessed by IPGRI, 1992; UPOV, 1985.

Morphological attributes and biological traits	<i>hollandicum</i> n=21		<i>giganteum</i> n=5		<i>hollandicum</i> x <i>giganteum</i> n=14		<i>silvestre</i> n=16	
	Mean	Range	Mean	Range	Mean	Range	Mean	Range
Winter damage	2.1	1-5	3.0	3-3	1.3	1-3	1.1	1-3
Plant height	6.3	5-7	7.0	7-7	7.0	7-7	4.9	3-7
Profuseness of flowers	5.7	3-7	3.8	3-7	5.4	3-7	7.1	7-9
Growth rate	4.8	3-5	3.5	3-5	5.0	5-5	3.7	3-5
Bunch diameter	5.4	3-7	7.0	7-7	6.0	5-7	5.6	5-7
Time of flowering	4.6	3-7	7.0	7-7	5.3	5-7	3.4	1-5

Fine-leafed *silvestre* form, exhibiting good over winter survival, re-growth and the highest profuseness of flowers, is designed for intensive grazing. Some *silvestre* accessions are ornamental which makes it possible to breed them for amenity purposes. This is especially relevant seeking to reduce nitrogen fertilizer use. Research into morphological and biological traits of white clover forms suggests a great diversity not only between the forms but also within the forms.

White clover yield is determined by some morphological traits (Collins *et al.*, 1991). Among the many factors that affect clover herbage yield are growth rate, plant height, bunch diameter, and flowering time (Table 3). The relation of these traits to the yield is defined by respective correlation coefficients  $r$  0.544, 0.495, 0.487 and 0.461,  $P < 0.01$ . Significant correlations at  $P < 0.05$  were determined between individual morphological traits: less susceptible to winter damage plants start flowering earlier but form fewer inflorescences. Plant height is directly significantly related to flowering time ( $r = 0.680$ ,  $P < 0.01$ ). A relationship between plant earliness and abundance of inflorescences and between some quality indicators of white clover was identified: earlier flowering plants accumulate lower MADF contents and more abundantly flowering plants exhibit poorer DMD. Concentration of HCN was positively correlated with plants winter damage ( $r = 0.423$ ,  $P < 0.05$ ). The pairs of quality components MADF and WSC, MADF and DMD, like concentrations of CP and WSC were inversely related. Similar trends of relationships between forage quality components are well known.

Large variation in DM yield and forage quality of white clover forms which are associated with morphological and biological traits has important implications for future white clover breeding programmes, where these traits could be incorporated as selection criteria for the development of high yielding accessions, adapted to soil properties, local climatic conditions, a range of managements, and of good quality.

Table 3. Relationship between morphological attributes, biological traits and quality parameters of white clover, n=33.

Name of a character in comparable pairs		A and B in regression equation $Y=A+BX$		Coefficients of correlation r
X	Y	A	B	
Winter damage	Profuseness of flowers	6.719	-0.459	- 0.347*
Winter damage	Time of flowering	3.754	0.494	0.401*
Plant height	Dry matter yield	1.628	0.568	0.495**
Plant height	Bunch diameter	3.754	0.281	0.344*
Plant height	Time of flowering	0.013	0.771	0.680**
Profuseness of flowers	Time of flowering	7.808	-0.527	- 0.566**
Dry matter yield	Growth rate	2.666	0.349	0.544**
Dry matter yield	Bunch diameter	3.706	0.347	0.487**
Dry matter yield	Time of flowering	2.422	0.456	0.461**
Bunch diameter	Time of flowering	1.376	0.617	0.444**
Winter damage	HCN	25.68	6,677	0.423*
Profuseness of flowers	DMD	83.993	-0.437	- 0.389*
Profuseness of flowers	MADF	18.734	0.337	0.444**
Time of flowering	DMD	79.125	0.492	0.408*
Time of flowering	MADF	22.64	-0.412	- 0.506**
CP	WSC	30.41	-0.678	- 0.472**
DMD	MADF	66.243	-0.559	- 0.829**
MADF	WSC	24.103	-0.34	- 0.402*

Significant: \*\* at  $P<0.01$ , \* at  $P<0.05$

## Conclusions

White clover varies with and within forms according to their herbage DM yield, morphological and biological properties, the concentration cyanogenic glycosides, but only slightly differ in the concentration of the main components of herbage quality. The morphological and biological traits well correlate with the yield, some traits - with quality indicators.

## Acknowledgements.

We would like to thank the Lithuanian State Science and Studies Foundation and the Lithuanian Ministry of Agriculture for the support (grant M-06003).

## References

- Collins R.P., Glendining M.J. and Rhodes I. (1991) The relationships between stolon characteristics, winter survival and annual yields in white clover (*Trifolium repens* L.). *Grass and forage science*, 45, 51-61.
- Dewhurst R.J., Fisher W.J., Tweed J.K.S. and Wilkins R.J. (2003) Comparison of grass and legume silages for milk production. 1. Production responses with different levels of concentrate. *Journal of Dairy Science*, 86, 2598-2611.
- Gustine D. L. and Elwinger G. F. (2003) Spatiotemporal genetic structure within white clover populations in grazed swards. *Crop Science*, 43, 337-344.
- IPGRI. (1992) Descriptors for white clover (*Trifolium repens* L.). International Plant Genetic Resources Institute, Rome, Italy. pp.1 - 52.
- Paplauskienė V. and Butkutė B. (2006) The contents of feeding value components and cyanogenic glycosides in white clover forms and genotypes. *Agriculture. Scientific articles*, 93 (3), 158-171.
- Sprainaitis A. and Paplauskienė V. (2002) White clover breeding material and wild ecotypes for the formation of genetic collection. *Biologija*. 4, 15-18.
- Sareen S. (2003) Variability in white clover from the Indian Himalaya. (accessed Aug 2006).
- UPOV (International Union for the Protection of New Varieties of Plants) (1985) Guidelines for the conduct of tests for distinctness, homogeneity and stability. White clover (*Trifolium repens* L.) /UPOV/ TG/38/6, pp.1-11.

# **Influence of contrasting environments on forage quality of ryegrass and four legumes growing in binary swards**

Gierus M.<sup>1</sup>, van Dorland H.A.<sup>2</sup>, Elgersma A.<sup>3</sup>, Kreuzer M.<sup>2</sup>, Loges R.<sup>1</sup>, Poetsch E.M.<sup>4</sup>, Smit H.J.<sup>3</sup>, Steinshamn H.<sup>5</sup>, Taube F.<sup>1</sup> and Wachendorf M.<sup>6</sup>

<sup>1</sup>*Institute of Crop Science and Plant Breeding – Grass and Forage Science/Organic Agriculture, University of Kiel, D-24118 Kiel, Germany*

<sup>2</sup>*ETH Zurich, Institute of Animal Science, CH-8092 Zurich, Switzerland*

<sup>3</sup>*Crop and Weed Ecology Group, Plant Sciences, Wageningen University, 6709 RZ Wageningen, The Netherlands*

<sup>4</sup>*Research and Education Centre Raumberg-Gumpenstein, Department for Grassland Management and Cultural Landscape, A-8952 Irdning, Austria*

<sup>5</sup>*Bioforsk - Organic Food and Farming Division, N-6630 Tingvoll, Norway*

<sup>6</sup>*Department of Grassland Science and Renewable Plant Resources, University of Kassel, 37213 Witzenhausen, Germany*

## **Abstract**

Forage legumes are valuable alternatives for mineral N fertilizers in grassland, due to their N fixing capacity and the assumed increase in forage quality of the sward. However, forage quality of binary swards may differ in response to site and legume species. The objective of the present study, carried out within the frame of the COST Action 852, was to identify the influence of legume species growing in contrasting environments on legume proportion, crude protein (CP) and metabolisable energy (ME) contents. At each of the five participating sites the experiment was carried out as a completely randomized block design with three replications. Four legume species were tested: white clover, red clover, alfalfa and birdsfoot trefoil. The first cut was performed in spring after first node detection in grass and repeated 30±3 days afterwards (5-cut system). Legume proportion varied largely from 5% to 79%, with birdsfoot trefoil showing the lowest legume proportion in the swards across sites. Alfalfa had the highest N contents at all sites. Results show that, especially in ME content, legumes are less responsive to variation due to contrasting environments than the companion grass.

Keywords: forage legumes, companion grass, forage quality, contrasting environments

## **Introduction**

Although grassland based production systems account for half of the animal requirements for feed in Europe, large amounts of protein-rich concentrate feeds are imported and the demand for high quality vegetable protein is still increasing. Forage legumes are valuable protein sources, providing alternatives for ruminant nutrition. Additionally, they may reduce the need for mineral nitrogen fertilizer, and contribute to reduce nitrogen losses on the farm. However, feed quality of forage-legume based swards may differ between sites in Europe due to environmental constraints. The objective of the present study was to characterize the influence of legume species and site on feed quality of forage legumes and companion grass grown in binary swards. The study is part of the EU-COST Action 852.



## Materials and methods

The same cultivars of white clover (*Trifolium repens* L.), red clover (*Trifolium pratense* L.), alfalfa (*Medicago sativa* L.) and birdsfoot trefoil (*Lotus corniculatus* L.) were established at each site as binary swards with perennial ryegrass (*Lolium perenne* L.) in a randomized block design with three replications. White clover, red clover, alfalfa and birdsfoot trefoil were sown at rates of 4, 8, 16, and 8 kg/ha, respectively, with 15 kg/ha of perennial ryegrass, or 20 kg/ha in a pure grass stand. In the year after sward establishment, swards were cut first when the first grass node was detectable. Subsequent cuts took place every 30±3 days yielding a total of 5 cuts. Samples were separated into legume, grass and weed fraction. Feed quality analysis comprises the determination of the contents of crude protein (CP) and metabolisable energy (ME) separately for the grass and legume fraction. The CP was calculated as total N × 6.25 and the ME content was estimated from the cellulase method (De Boever *et al.*, 1988). The equations applied were as follows (Weissbach *et al.*, 1996):

$$ME_{\text{grass}} \text{ (MJ/kg DM)} = 13.98 - 0.0147*CA - 0.0102*RE - 0.00000254*RE^2 + 0.00234*CP$$

$$ME_{\text{legume}} \text{ (MJ/kg DM)} = 13.98 - 0.0147*CA - 0.0137*RE + 0.00234*CP$$

where CA = crude ash; RE = residue after enzymatic digestion; CP = crude protein

Data on a year basis were used for analysis of variance, and means were compared using Student's T-Test. The probabilities were adjusted using the Bonferroni-Holm test.

## Results

Table 1 shows the average weather data for the participating sites from March 31<sup>st</sup> to October 1<sup>st</sup>. Norway had the lowest global radiation and average temperature.

Table 1. Weather data of the experimental year at the participating sites

Site	Temperature, °C	Precipitation, mm	Global radiation, J/cm <sup>2</sup>
Norway	10.6	551	1274
Switzerland	15.3	722	1546
Netherlands	14.9	396	1568
Germany 2004*	13.8	418	1550
Germany 2005*	14.1	325	1551

\* In Germany the experiment was established separately in two subsequent years.

The results of the ME content of companion grass and legumes are shown in Tables 2 to 4. For the companion grass, the interaction site × sward type was significant (Table 2). The ME content of the companion grass was highest in Norway.

Table 2. Metabolisable energy content of the companion grass (perennial ryegrass)

Site/sward	White clover	Red clover	Alfalfa	Birdsfoot trefoil	Pure stand
Norway	11.8 <sup>a</sup>	11.5 <sup>a</sup>	11.6 <sup>a</sup>	11.9 <sup>a</sup>	11.9 <sup>a</sup>
Switzerland	10.7 <sup>b</sup>	10.4 <sup>b</sup>	10.8 <sup>b</sup>	10.4 <sup>b</sup>	10.6 <sup>bc</sup>
Netherlands	10.8 <sup>b</sup>	10.8 <sup>b</sup>	10.6 <sup>b</sup>	10.5 <sup>b</sup>	10.9 <sup>b</sup>
Germany 04	10.9 <sup>b*</sup>	10.7 <sup>b*</sup>	10.5 <sup>b</sup>	10.4 <sup>b</sup>	10.3 <sup>c</sup>
Germany 05	10.5 <sup>b</sup>	10.8 <sup>b</sup>	10.6 <sup>b</sup>	10.4 <sup>b</sup>	10.4 <sup>bc</sup>

SE=0.15; n=73

\* significantly different from pure grass stand ( $P<0.05$ ) within sites

<sup>a,b</sup> site means carrying no common superscript are significantly different ( $P<0.05$ )

For the ME content of forage legumes only the main effects were significant (Tables 3 and 4). White clover with 10.9 MJ ME/kg DM was the legume species with the highest ( $P<0.05$ ) ME content across sites. In Norway birdsfoot trefoil did not perform well.

Table 3. Metabolisable energy content of forage legumes – site effect

Site	ME, MJ/kg DM
Norway	10.5 <sup>c</sup>
Switzerland	10.3 <sup>c</sup>
Netherlands	10.9 <sup>a</sup>
Germany 04	10.4 <sup>c</sup>
Germany 05	10.7 <sup>b</sup>

SE=0.07; n=45;  $P<0.05$

Table 4. Metabolisable energy content of forage legumes – legume species effect

Species*	ME, MJ/kg DM
White clover	10.9 <sup>a</sup>
Red clover	10.5 <sup>b</sup>
Alfalfa	10.3 <sup>b</sup>

SE=0.05; n=45;  $P<0.05$

\* Birdsfoot trefoil was excluded due to missing values in Norway

The CP content of the companion grass is shown in Table 5. The interaction site × sward type was significant. The grass grown in Switzerland had the highest CP contents and that of Germany 05 showed the lowest contents. Grass grown with birdsfoot trefoil showed similar CP contents as the pure grass stand. In Norway, only grass growing with red clover showed higher CP contents compared to the pure stand.

Table 5. Crude protein content of the companion grass (perennial ryegrass)

Site/sward	White clover	Red clover	Alfalfa	Birdsfoot trefoil	Pure stand
Norway	13.2 <sup>c</sup>	14.2 <sup>b*</sup>	12.4 <sup>c</sup>	11.8 <sup>c</sup>	11.8 <sup>b</sup>
Switzerland	18.4 <sup>ab*</sup>	17.7 <sup>a*</sup>	19.4 <sup>a*</sup>	15.9 <sup>a</sup>	15.9 <sup>a</sup>
Netherlands	19.7 <sup>a*</sup>	18.6 <sup>a*</sup>	16.8 <sup>b*</sup>	14.2 <sup>b</sup>	13.2 <sup>b</sup>
Germany 04	17.4 <sup>b*</sup>	15.0 <sup>b*</sup>	15.6 <sup>b*</sup>	13.2 <sup>bc*</sup>	10.2 <sup>c</sup>
Germany 05	10.5 <sup>d*</sup>	11.3 <sup>c*</sup>	10.2 <sup>d*</sup>	8.5 <sup>d</sup>	7.2 <sup>d</sup>

SE=0.60; n=73

\* significantly different from pure grass stand ( $P<0.05$ ) within sites

<sup>a,b</sup> site means carrying no common superscript are significantly different ( $P<0.05$ )

The CP content of the forage legumes is shown in Table 6. The interaction site × sward type was significant. All legume species grown in Norway showed significantly lower CP contents than in the other sites. Considering legume species, alfalfa had the highest CP contents between all sites and red clover the lowest. An exception was Germany, where no differences for legumes species were observed.

Table 6. Crude protein content (% DM) of forage legumes at different sites

Site/species	White clover	Red clover	Alfalfa	Birdsfoot trefoil <sup>1)</sup>
Norway	20.4 <sup>cB</sup>	20.1 <sup>cB</sup>	22.4 <sup>cA</sup>	-
Switzerland	24.5 <sup>bA</sup>	22.3 <sup>bB</sup>	25.6 <sup>bA</sup>	25.2
Netherlands	26.0 <sup>aA</sup>	23.4 <sup>bB</sup>	27.1 <sup>aA</sup>	26.6
Germany 04	26.0 <sup>aA</sup>	25.1 <sup>aA</sup>	25.8 <sup>abA</sup>	26.1
Germany 05	23.4 <sup>bA</sup>	24.4 <sup>abA</sup>	24.5 <sup>bA</sup>	24.3

SE=0.39; n=45; <sup>1)</sup> Birdsfoot trefoil was excluded from calculations due to missing values in Norway

<sup>a,b</sup> site means within legume species carrying no common superscript are significantly different ( $P<0.05$ )

<sup>A,B</sup> legume species means within site carrying no common superscript are significantly different ( $P<0.05$ )

Table 7 shows the legume proportion at each site. The interaction site × sward type was significant. Low proportions of birdsfoot trefoil were observed at most sites, except in Germany 04.

Table 7. Average yearly legume proportion (%) of the swards at different sites on a DM basis

Site/sward	White clover	Red clover	Alfalfa	Birdsfoot trefoil
Norway	29.5 <sup>bB</sup>	44.8 <sup>bA</sup>	23.1 <sup>dB</sup>	4.9 <sup>cC</sup>
Switzerland	16.7 <sup>cB</sup>	46.6 <sup>bA</sup>	57.3 <sup>bA</sup>	8.2 <sup>cB</sup>
Netherlands	43.7 <sup>abAB</sup>	51.8 <sup>abA</sup>	38.5 <sup>cB</sup>	21.9 <sup>bC</sup>
Germany 04	38.6 <sup>bD</sup>	65.3 <sup>aB</sup>	79.0 <sup>aA</sup>	54.0 <sup>aC</sup>
Germany 05	53.4 <sup>aA</sup>	61.7 <sup>aA</sup>	59.6 <sup>bA</sup>	13.0 <sup>bcB</sup>

SE=3.4; n=60

<sup>a,b</sup> site means within legume species carrying no common superscript are significantly different ( $P<0.05$ )

<sup>A,B</sup> legume species means within site carrying no common superscript are significantly different ( $P<0.05$ )

## Discussion

Based on the results presented, the influence of sites on forage quality was most pronounced for the companion grass. The site effect was a result of different environmental conditions, as the grass growing in Norway had the lowest average temperature in the period, resulting in high ME contents. This confirms previous observations, as cell wall constituents deposited at lower temperatures are less lignified and higher in digestibility, and storage carbohydrates tend to accumulate in leaf tissue (Chatterton *et al.*, 1989). Although white clover was the legume species with the highest ME content, differences due to site were of minor magnitude, when compared to the companion grass.

Legume proportion varied largely from 5% to 79% for all species and sites, with birdsfoot trefoil showing the lowest legume proportion. This large variation in legume proportion affected the CP content of the companion grass. However, the differences in the increase in CP content in the companion grass with increasing legume proportion seems to be more pronounced for legume species than for contrasting sites.

The CP contents of forage legumes ranged from 20.4 to 27.1% DM considering sites and legume species. Differences in CP content between species were of minor magnitude. The frequent cutting each 30 days may have been one of the reasons for that, as legumes were always cut in an early development stage.

## Conclusions

In binary swards with legumes, the nutritional quality of the companion grass has to be considered especially in northern Europe as it may influence forage quality positively. The observed differences between sites and legume species for ME and CP contents in legumes are of marginal relevance for ruminants. The results suggest that, although grown in contrasting environments, any legume species could be used in binary swards in the first production year producing forage of similar CP and ME contents when cut every 30 days. The weak establishment of birdsfoot trefoil in most sites may limit its use, though.

## References

- Chatterton N.J., Harrison P.A., Bennett J.H. and Asay K.H. (1989) Carbohydrate partitioning in 185 accessions of Gramineae grown under warm and cool temperatures. *Journal of Plant Physiology* 134, 169-179.
- De Boever J. L., Cottyn B.G., Buysse F.X. and Vanacker J.M. (1988) The use of a cellulase technique to predict digestibility, metabolizable and net energy of forages. *Animal Feed Science and Technology* 19, 247-260.
- Weissbach F., Kuhla S. and Schmidt L. (1996) Estimation of the metabolizable energy in forages by a cellulase method. *Proceedings of the Society of Nutrition Physiology* 5, 115.

# Herbage quality and competitiveness of grassland legumes in mixed swards

Søgaard K. and Weisbjerg, M.R.

*Faculty of Agricultural Sciences, University of Aarhus, Research Centre Foulum, DK-8830 Tjele, Denmark*

## Abstract

A change from grazing to cutting on intensive managed grasslands has increased the interest for other grassland species than perennial ryegrass (*Lolium perenne*) and white clover (*Trifolium repens*). Lucerne (*Medicago sativa*), red clover (*Trifolium pratense*) and festulolium (*XFestulolium*) were therefore, together with perennial ryegrass and white clover, analyzed for competitiveness and herbage quality in different mixtures, each with one grass and one legume. Red clover was more competitive than the other legumes in mixtures with both grass species. Festulolium was more competitive than perennial ryegrass in mixtures with all legumes. Concerning cell wall characteristics, digestibility of organic matter and content of crude protein there was a big difference between leaves and stem of lucerne, whereas the difference was less in red clover. Changes in leaf/stem ratio was more important for the decrease in herbage quality with increased maturity than changes in quality within the fractions leaf and stem, respectively. Leaf/stem ratio in the legumes was not affected by the grass species, whereas the legume species affected the leaf/stem in the grasses.

Keywords: lucerne, red clover, white clover, festulolium, perennial ryegrass, herbage quality

## Introduction

The proportion of grasslands with a cutting-only regime is increasing primarily because the increase in farm size has declined the number of herds grazing. Therefore species as red clover, lucerne and festulolium are becoming more used in grass-leguminous stands. The expectation is that the yield potential is higher but that the energy value is lower for dairy cows in these species compared to the common used species, white clover and perennial ryegrass. However, knowledge is lacking on the possibilities for mixing species for optimizing both yield and quality. The aim of the experiment was to study the interactions between sward composition and herbage quality and the growth of the individual species in mixtures with one legume and one grass. Yield, botanical composition and herbage quality of leaves and stem are reported.

## Materials and methods

On a sandy clayey soil, white clover (c. Milo), red clover (c. Rajah), lucerne (c. Pondus), perennial ryegrass (c. Mikado) and festulolium (c. Perun, *Lolium multiflorum* type) were established in mixed stand with one legume and one grass with two replicates in 2005. In 2006 four cuts were harvested, and all plots were fertilized with 120 N ha<sup>-1</sup>; 42, 30, 24 and 24 kg N to the respective cuts. Spring growth and second regrowth were examined by harvesting plots at 7 cm stubble with one-week interval. Botanical composition was examined by hand separation. The species were separated into leaves, including laminae and petiole, and stems, including floral parts. The samples were dried at 60°C and analysed for *in vitro* organic digestibility (IVOMD; method of Tilley and Terry), fibre (neutral detergent fibre (NDF), acid

detergent fibre (ADF) and acid detergent lignin (ADL); Van Soest method) and N (Dumas-method).

## Results

The herbage mass and the legume proportions were generally higher in the red clover swards than in the lucerne and white clover swards both with perennial ryegrass (Figure 1A) and festulolium (data not shown). The proportion of perennial ryegrass was on average 20, 32 and 55 % of DM ( $P < 0.0001$ ) for the red clover, lucerne and white clover sward, respectively. Festulolium competed stronger and the proportions were significantly higher, on average 40, 63 and 74 % of DM ( $P < 0.0001$ ). The proportions of legumes were generally higher in second regrowth than in spring growth.

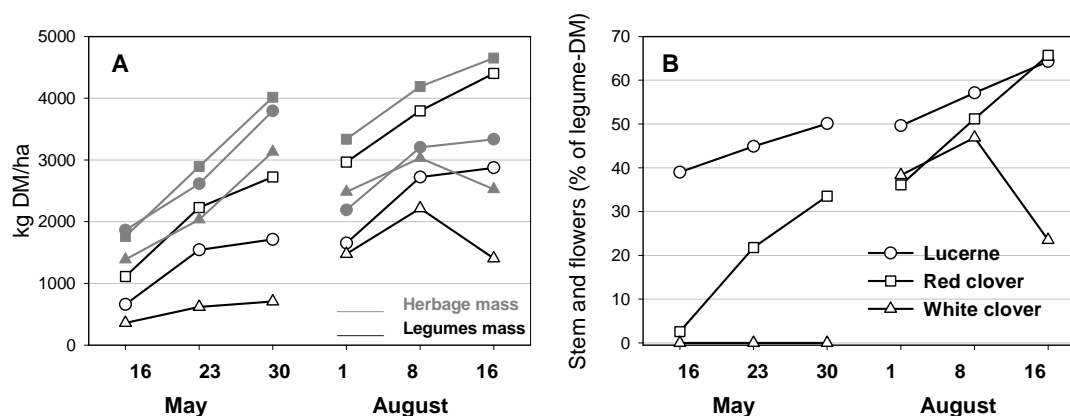

Figure 1. Yield of legume-perennial ryegrass mixtures during spring growth and second regrowth. Total herbage (legume+grass) and legume mass (A) and proportion of legume stem incl. flowers of legume DM (B).

The proportion of stem in red clover increased highly during the two periods (Figure 1B). Lucerne stem proportion was opposite relatively high from the beginning. For white clover there were no flowers in spring growth. The grass species did not affect the leaf/stem of legumes (data not shown), but the legumes affected on the other hand the leaf/stem of the grass species (Table 1). In spring growth the proportion of grass stem of both perennial ryegrass and festulolium was highest in lucerne swards and in second regrowth there was a significant higher stem proportion of perennial ryegrass in red clover swards.

Table 1. Grass stem proportion (% stem of grass-DM) in grass/legume swards.

Sward with legume:	Spring growth		Second regrowth	
	Per. ryegrass	Festulolium	Per. Ryegrass	Festulolium
Lucerne	43.8	53.0	15.8	62.3
Red clover	33.6	43.1	24.7	61.9
White clover	34.8	48.1	14.3	59.1
LSD <sub>0.05</sub>	2.1	6.0	8.2	8.7

The leaves of the different legumes had a very different content of hemicellulose (NDF-ADF) (Figure 2B). It was lowest in white clover and highest in red clover leaves, especially in the second regrowth, with an average content of 4.2 and 10.9% of DM ( $P < 0.0001$ ), respectively. The hemicellulose content in red clover leaves was approximately half of that in grass leaves, on average 20.2%. The hemicellulose content in the stems, including flowers, was lowest in white clover, whereas the contents in red clover and lucerne were on the same level. The cellulose (ADF-ADL) content was lowest in lucerne leaves and highest in lucerne stems

(Figure 2 C). In second regrowth there was on average 13.1 and 33.4% of DM ( $P < 0.0001$ ) cellulose in lucerne leaves and stems, respectively. The level for red and white clover was more similar. The lignin (ADL) content was high in lucerne and white clover stems/flowers, and considerably lower in red clover stems, especially in spring growth. The lignin content in the leaves was not significantly different between the legume species. With the exception of lucerne leaves, the content of cell wall (NDF), hemicellulose, cellulose and lignin, was higher in the summer than in spring, and the differences between the plant components was larger in summer than in spring. During both periods the cell wall composition did not change severely, although the herbage mass increased strongly. The main change was an increase in lignin content in the stems.

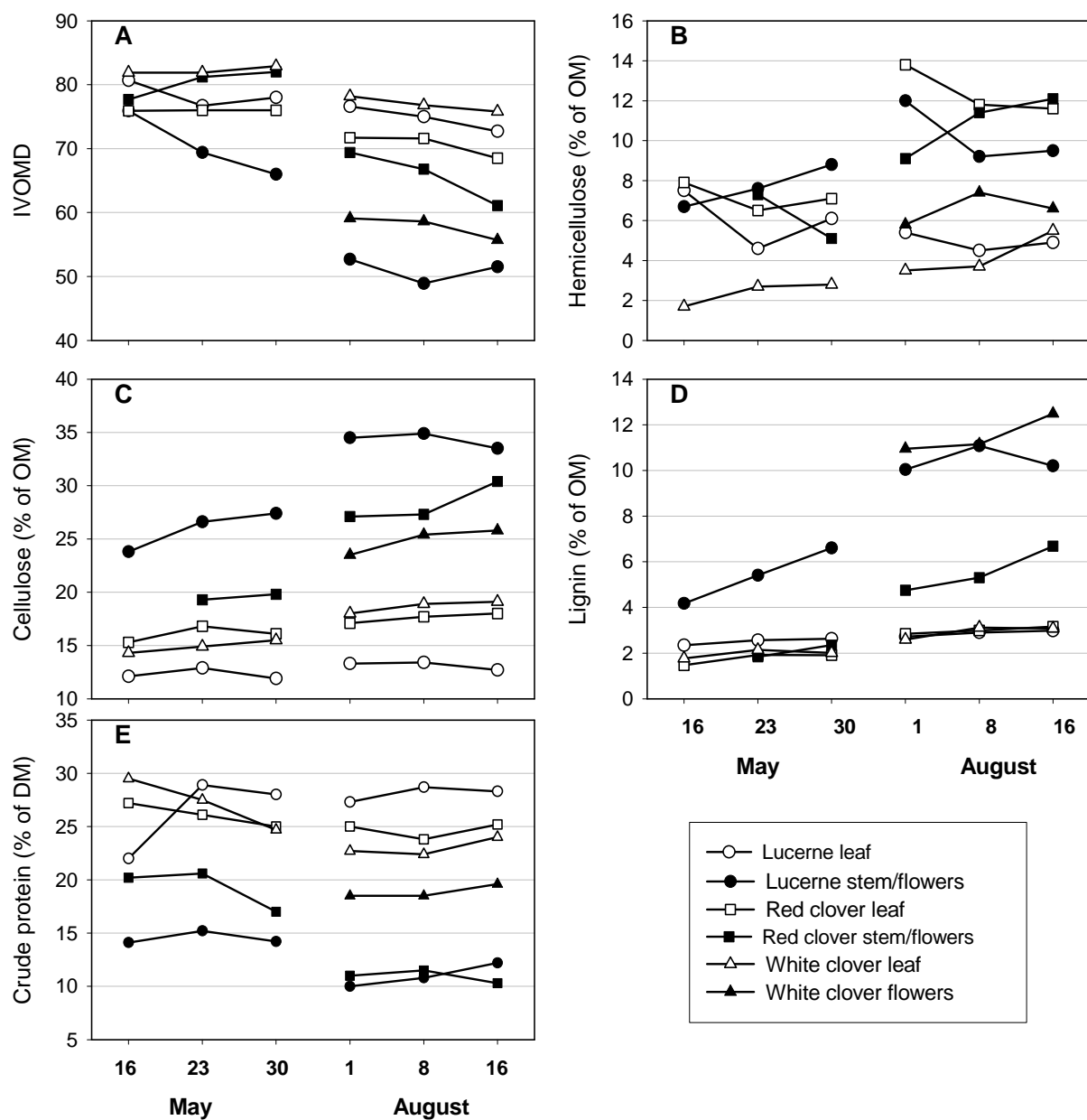

Figure 2. Herbage quality during spring growth and second regrowth. *In vitro* organic matter digestibility (A) and content of hemicellulose (NDF-ADF) (B), cellulose (ADF-ADL) (C), lignin (ADL) (D) and crude protein (E).

Cell wall composition was roughly reflected in IVOMD with a greater difference between the plant components in second regrowth (Figure 2 A). IVOMD was highest in white clover leaves and lowest in lucerne stem. The difference between red clover leaves and stems was not as high as for the other legumes. Lucerne leaves, in the two periods, were very similar concerning IVOMD, whereas other plant components were considerable lower in IVOMD in the second regrowth. The crude protein content was, with the exception of the first sampling date, highest in lucerne leaves and lowest in lucerne stems (Figure 2 E). In the second period the content in red clover stems was also low. There was a smaller difference between white clover leaves and flowers than between red clover leaves and stems incl. flowers.

## Discussion

Although the herbage mass highly increased during the two periods, there were limited changes in the quality parameters in the leaves and stems. The herbage quality of the whole sward therefore depended highly of the leaf/stem ratio, and effects on leaf/stem would therefore have an effect. However, leaf/stem ratio of legumes was not affected by the grass species in the sward. In spring growth, the proportion of grass stem was higher in the lucerne swards than in the other legume swards, and by that lucerne affected the herbage quality of the whole sward.

The largest change during the periods was found in lucerne stems especially for lignin content and IVOMD. The lignin content was relatively high in lucerne stems, which is confirmed by Couchman (1960) who found a three-time higher content in stem than in leaf. Lucerne was thus composed of two very different components, leaves and stems, and the cell wall characteristics of these would give a high and a low energy value, respectively. The same was valid for white clover in the summer period, as the lignin content was high and IVOMD was low in the white clover flowers. Red clover stems and leaves did not show that great differences in cell wall characteristics as the other legumes and was in that way a more homogeneous sward. Red clover leaves had a lower IVOMD and higher hemicellulose content than lucerne and white clover leaves. This lower digestibility was also found by Wilman and Altimimi (1984).

At the same amount of herbage mass, the energy value of lucerne would be lower than of red clover due to the higher proportion of lucerne stem and to the high lignin content and low IVOMD in lucerne stem. The higher energy value in red clover is in accordance with Cassida *et al.* (2000).

## Conclusion

The highest competitive strength was found in red clover and festulolium for the legume and grass species, respectively. For herbage quality parameters red clover crop fractions were more homogeneous than lucerne crop fractions, as lucerne showed a great difference between leaves and stem.

## References

- Cassida K.A., Griffin T.S., Rodriguez J, Patching S.C., Hesterman O.B. and Rust S.R. (2000) Protein degradability and forage quality in maturing alfalfa, red clover, and birdsfoot trefoil. *Crop Science* 40, 209-215.
- Couchman J.F. (1960) The distribution of carbohydrates, nitrogen and lignin in soluble fractions of the stems and leaves of lucerne hay. *Grass and Forage Science* 15, 169-173.
- Wilman D. and Altimimi A.K. (1984) The in-vitro digestibility and chemical composition of plant parts in white clover, red clover and lucerne during primary growth. *Journal of the Science of Food and Agriculture* 35, 133-138.

# Performance of alternative and novel forage legumes compared with white clover

Sölter U.<sup>1</sup> and Hopkins A.<sup>2</sup>

<sup>1</sup>*Institute of Crop and Grassland Science, Federal Agricultural Research Centre, Braunschweig, Germany.*

<sup>2</sup>*IGER North Wyke, EX20 2SB, UK, and GES-Consulting, 27 Brownings Mead, Dunsford, Exeter, EX6 7JJ, UK.*

## Abstract

At sites in northern Germany (site 1) and south-west England (site 2) production and botanical composition of different grass-legume swards were compared under cutting in small-plot experiments linked to adjacent grazing experiments on the same sward types. At site 1 a four-species grass mixture was sown with the legumes, and at site 2 perennial ryegrass (PRG, *Lolium perenne*) was chosen. Swards sown with white clover (WC, *Trifolium repens*) were compared with birdsfoot trefoil (BFT, *Lotus corniculatus*) at both sites, and with red clover (RC, *Trifolium pratense*) at site 1 and Caucasian clover (CC, *Trifolium ambiguum*) at site 2. Sowing was carried out in summer 2002 and production and botanical composition recorded during 2003 and 2004 (years 1 and 2). At site 1 in year 1, total annual production was not recorded but the legume in the WC- and RC-grass swards was 0.70 of total harvested DM, greater ( $P<0.01$ ) than BFT (0.37 of total DM). In year 2, total DM (and sown legume) production in t/ha from RC-grass swards was 7.3 t (5.0 t RC), greater than BFT-grass at 5.0 t (1.7 t BFT) ( $P<0.01$ ) and WC-grass at 5.5 t (2.0 t WC). Legume proportion of RC swards was 0.69 of total DM, which was greater ( $P<0.01$ ) than WC (0.37) and BFT (0.34) swards. At site 2 in year 1, total annual production (and sown legume production) in t DM/ha from BFT-PRG swards was 10.3 t (3.1 t BFT), greater than ( $P<0.01$ ) WC-PRG at 8.3 t (3.0 t WC), greater than ( $P<0.01$ ) CC-PRG at 5.4 t (0.6 t CC). In year 2 production from BFT-PRG swards at 9.6 t DM/ha, was greater ( $P<0.01$ ) than either CC-PRG (6.2 t) or WC-PRG (5.5 t). In the linked grazing experiments at site 1 similar production patterns for each of the three treatments were found, while the superior production of the BFT swards was also obtained at site 2.

Keywords: white clover, lotus, Caucasian clover, red clover

## Introduction

As a part of the EU-funded LEGGRAZE project (QL K5 CT-2001-02328) which provided a sound scientific basis for the use of legume-based swards in environmentally sustainable grazing systems, linked investigations to non-grazed plots under a cutting regime were carried out in 2003 and 2004. This paper reports results on the botanical composition and dry matter yield at the sites in northern Germany (site 1) and south-west England (site 2).

## Materials and methods

Field experiments were established in northern Germany, site 1, (52°N, 9°E) and south-west England, site 2, (50°N, 3°W) in 2002. The experiments were laid out as a randomised block design with three replicates. Soils were sandy loam and received no fertilizer during the experimental period. Treatment plots at site 1 were 50 m x 8 m, and at site 2 they measured 6 m x 4 m. At site 1 a grass mixture (*Lolium perenne*, *Festuca pratensis*, *Phleum pratense*,



*Poa pratensis*) was sown with the legumes and at site 2 perennial ryegrass (PRG, *Lolium perenne*) was chosen. Swards sown with white clover (WC, *Trifolium repens*) were compared with birdsfoot trefoil (BFT, *Lotus corniculatus*) at both sites, and with red clover (RC, *Trifolium pratense*) at site 1 and Caucasian clover (CC, *Trifolium ambiguum*) at site 2. Sowing was carried out in summer 2002 and dry matter production (DM) and botanical composition were recorded during 2003 and 2004 (years 1 and 2). The sward was mown and fresh weights recorded from each treatment plot. At site 1 these were taken on 3 occasions in year 1 and 6 times in year 2. At site 2 there were 4 cuts made in each year. Fresh weight samples (c. 1.5 kg) were taken from each plot for DM determination and were hand sorted to determine the proportion of sown legume in the harvested DM. In the statistical analysis data on legume proportion and DM yield were analysed for each experimental site using the GLM procedure and the Tukey-Test for least square means and significant differences between the treatments within a production year (SAS, 2004).

## Results and discussion

The proportion of legumes in the sward at site 1 in year 1 was greatest ( $P<0.01$ ) for white clover and red clover at 0.70 of the DM, compared with birdsfoot trefoil at 0.37 of the DM in the legume-grass mixtures, the total dry matter was not documented (Table 1). In year 2 the proportion of red clover and birdsfoot trefoil was similar to the previous year while the white clover proportion declined to 0.34 of the DM (significantly greater for red clover at  $P<0.01$ ). The total dry matter of the swards in year 2 was highest ( $P<0.01$ ) for red clover (7.3 t ha<sup>-1</sup>) compared to birdsfoot trefoil (5.0 t ha<sup>-1</sup>), while white clover was intermediate (5.5 t ha<sup>-1</sup>). The decline of the white clover proportion in the swards from year 1 to year 2 could be explained by the extreme drought conditions that occurred in year 1 (2003). Dry conditions might have affected the stolons, which appeared to be almost destroyed. This observation was also made at the linked grazing experiments at that site (Sölter *et al.*, 2007). Red clover and birdsfoot trefoil seemed to better withstand the dry weather conditions with a stable legume proportion in the sward in both years. Total DM yields of the legume-grass mixtures were lower than results from other experiments in Germany stated for white clover- and red clover-grass swards (Kleen *et al.*, 2006) and for birdsfoot trefoil-grass mixtures (Opitz von Boberfeld and Laser, 1999). A possible reason for the low DM yields in year 2 at site 1 might have been the cutting frequency (6 cuts) as a high cutting regime has been widely reported to have a negative influence on the regrowth of the legumes leading to reduced DM production (Frame, 2005).

Table 1. Total dry matter (DM) and proportion of legume (percentage of legume in brackets) in the total DM of the three treatments at site 1 in year 1 and year 2

	[t ha <sup>-1</sup> ]											
	white clover-grasses				birdsfoot trefoil-grasses				red clover-grasses			
	total DM	SD	legume DM	SD	total DM	SD	legume DM	SD	total DM	SD	legume DM	SD
year 1	n.d.	n.d.	(70a)	(8)	n.d.	n.d.	(37b)	(0)	n.d.	n.d.	(71a)	(2)
year 2	5.5ab	0.4	2.0b	0.8	5.0b	0.4	1.7b	0.3	7.3a	0.8	5.0a	0.6
			(37b)	(13)			(34b)	(2)			(69a)	(1)

n.d.: not determined, SD: standard deviation

values in the same row with different letters are significantly different at  $P<0.01$

At site 2 in year 1 the proportion of the legumes in the sward was greatest ( $P<0.01$ ) for the white clover and birdsfoot trefoil treatments (0.37 and 0.30 of the DM, resp.) compared with Caucasian clover (0.10 of the DM) (Table 2). The total DM yield in year 1 was greater

( $P < 0.01$ ) for birdsfoot trefoil-grass ( $10.3 \text{ t ha}^{-1}$ ) compared with white clover-grass ( $8.3 \text{ t ha}^{-1}$ ) and Caucasian clover-grass ( $5.4 \text{ t ha}^{-1}$ ). In year 2 the total DM yield declined rapidly for white clover-grass ( $5.5 \text{ t ha}^{-1}$ ) but Caucasian clover-grass achieved higher DM yield ( $6.2 \text{ t ha}^{-1}$ ) while birdsfoot trefoil-grass kept its high level of total DM yield ( $P < 0.01$ ) compared to the previous year. The DM production of the white clover-grass sward and its legume proportion are in the range of experimental yields in the United Kingdom (Frame, 2005).

The DM yields of birdsfoot trefoil-grass swards are in line with previously results reported by Hopkins *et al.* (1996) and Hopkins and Johnson (2004), although the legume proportion in their experiments was higher in the first year. Swards of Caucasian clover are well known to produce low levels of DM in the first years (Taylor and Smith, 1998) and the contribution of Caucasian clover to the DM yield in mixed swards has been reported in previous studies (Martin, 1989). The slow establishment of Caucasian clover was also observed in the linked grazing trials (Sölter *et al.*, 2007).

Table 2: Total dry matter (DM) and proportion of legume (percentage of legume in brackets) in the total DM of the three treatments at site 2 in year 1 and year 2

	[t ha <sup>-1</sup> ]											
	white clover-grass				birdsfoot trefoil-grass				Caucasian clover-grass			
	total DM	SD	legume DM	SD	total DM	SD	legume DM	SD	total DM	SD	legume DM	SD
year 1	8.3b	0.5	3.0a (37a)	0.1 (4)	10.3a	0.5	3.1a (30a)	0.2 (3)	5.4c	0.5	0.6b (10b)	0.2 (4)
year 2	5.5b	0.5	n.d.	n.d.	9.6a	1.0	n.d.	n.d.	6.2b	0.5	n.d.	n.d.

n.d.: not determined, SD: standard deviation

values in the same row with different letters are significantly different at  $P < 0.01$

## Conclusions

Birdsfoot trefoil-grass swards produced similar DM yields, with sufficient legume proportions in the herbage, to white clover-grass swards under the given experimental conditions at both sites. At site 1 (northern Germany) red clover-grass maintained a stable and high legume proportion in both years. The two-year experimental period was too short for full establishment of an adequate proportion of Caucasian clover in the sward at site 2 (south-west England).

## References

- Frame J. (2005) Forage legume profiles. Forage Legumes for Temperate Grasslands. FAO, Rome and Enfield, NH, USA: Science Publishers Inc.
- Hopkins A. and Johnson R.H. (2004) Forage production and persistency of Lotus-based swards under organic management. Hopkins A. (ed.) Organic Farming - science and practice for profitable livestock and cropping. British Grassland Society Occasional Symposium No. 37. Reading, UK, British Grassland Society, pp. 57-60.
- Hopkins A., Martyn T.M., Johnson R.H., Sheldrick R.D. and Lavender R.H. (1996) Forage Production by two *Lotus* species as influenced by companion grass species. Grass and Forage Science, 51, 343-349.
- Kleen J., Gierus M. and Taube F. (2006) Performance of several forage legumes submitted to different management systems. Grassland Science in Europe, 11, 381-383.
- Opitz v. Boberfeld W. and Laser H. (1999) Einfluss von *Lotus corniculatus* auf die Nutzungselastizität bestandsprägender Gräser der Extensiv-Weiden (Effect of *Lotus corniculatus* on the elasticity of forage utilization of dominant grass species in extensive pastures). Pflanzenbauwissenschaften, Verlag Eugen Ulmer GmbH and Co., Stuttgart, 3 (2), 88-93.
- SAS Institute Inc. (2004) SAS 9.1.2. Cary, NC: SAS Institute Inc.
- Sölter U., Hopkins A., Sitzia M, Goby J.-P. and Greef J. M. (2007) Herbage mass and herbage quality of a range of grazed legume swards under Mediterranean and cool temperate conditions. Grass and Forage Science (submitted).
- Taylor R.W. and Smith R.R. (1998) Kura clover (*Trifolium ambiguum* M.B.) breeding, culture, and utilization. Advances in Agronomy, 63, 153-178.

# Do sward quality and production depend more on grazing intensity or floristic composition?

Rossignol N., Bonis A. and Bouzillé J.-B.

*University of Rennes 1, UMR CNRS ECOBIO, Campus de Beaulieu, 35042 RENNES Cedex, France*

## Abstract

The aim of this study was to assess the impact of defoliation frequency on production and quality of the vegetation in wet grassland. In this permanent grassland, spatial variations of grazing intensity led to heterogeneity of the vegetation. This *in situ* study involves six plant patches with contrasted floristic composition, either from mesophilous or mesohygrophilous vegetation and usually submitted to three different intensities of grazing. Three treatments of defoliation frequency were applied to these patches. Results showed that defoliation stimulated plant nitrogen content of the patches while the impact of defoliation on plant production differed amongst patches. For the mesophilous patches, increasing defoliation frequency decreased plant production. This decrease was the lowest for the usually intensively-grazed patch. For the mesohygrophilous patches, low defoliation frequency stimulated the production of all the patches. The usually lightly-grazed patch showed the greatest production when defoliated while the usually intensively-grazed patch exhibited the lowest production whatever the defoliation treatment. For the mesophilous patches, the vegetation had adopted a strategy of tolerance to defoliation while grazing led to vegetation with grazing-avoidance characteristics on the mesohygrophilous community.

Keywords: defoliation frequency, floristic composition, grassland, primary production

## Introduction

In the humid grasslands of the Marais Poitevin (France), heterogeneous grazing and recurrent spatial variations of grazing intensity led to patchy structure of the vegetation (Loucougaray *et al.* 2004). This herbivore-driven heterogeneity of the vegetation led to variation of productivity and plant quality within the grazed plant communities (Bonis *et al.* 2005). It is known that differences in defoliation frequency can influence quantity and quality of plant production (Milchunas *et al.*, 1995; Ferraro and Oesterheld, 2002). It has been suggested that low intensity of defoliation can stimulate primary productivity (Dyer *et al.*, 1993). Grazing intensity influences floristic composition and plant strategies (Milchunas and Lauenroth, 1993). The impact of the defoliation exerted by herbivores on the vegetation could differ depending on whether grazing led to a grazing-tolerant vegetation or not (del-Val and Crawley, 2005). In this study we tested whether vegetation usually intensively grazed was less affected by defoliation than vegetation usually less or not grazed.

## Materials and methods

The study was conducted within an experimental design established in 1995 on a commonly grazed land (250 ha) situated in the Marais Poitevin (120 000 ha), a large wetland situated on the Atlantic coast of France. The studied wet grassland is a former salt-marsh, embanked during the 10<sup>th</sup> century and used for centuries for grazing with horses and cattle. The grazing season generally lasts from the end of April to December at the latest. A remnant

topographical gradient (up to 50 cm) from ancient salt-marshes distinguished three levels: low-lying depressions flooded 3 to 5 months per year; gentle slopes flooded 2 to 3 weeks a year, where clay-rich soils have remained saline; and flats that are never flooded (Bonis *et al.* 2005).

Table 1: Main characteristics of the plant patches, canopy height (cm), specific richness (S) and Shannon's index of diversity (H') at the beginning of the experiment (May 2004).

Previous grazing regime	Mesophilous community				Meso-hygrophilous community			
	Patch	Height	S	H'	Patch	Height	S	H'
Ungrazed	M0	49.11a	3.50a	0.47a	Mh0	38.28a	4.75a	0.78a
Low	M1	34.09b	6.92b	1.88b	Mh1	22.88b	7.42a	1.54b
High	M2	16.39c	7.50b	1.80b	Mh2	10.16c	7.25a	2.26c

Within each community, same letters show the absence of significant differences within each column (post-hoc Fisher's test).

We studied the mesophilous (M) plant community which occurs on the flats and the mesohygrophilous (Mh) one which occurs on the slopes. For each plant community, M and Mh, we chose one patch ungrazed since 1995 (M0 and Mh0), one patch previously grazed at low intensity (M1 and Mh1) and one patch previously grazed at high intensity (M2 and Mh2) (Table 1). Ungrazed patches were sampled from an enclosure (4 ha) that had not been grazed since 1995 and grazed patches were sampled from two enclosures (1 ha each) that had been grazed with 2 cattle ha<sup>-1</sup>. Within grazed enclosures heterogeneous grazing creates plant mosaic composed of lightly- and intensively-grazed patches. Patches were distinguished on the basis of their mean canopy height and floristic composition (Table 1).

There were four replicates for each of the six patches resulting in 24 experimental plots. Experimental plots (10 m<sup>2</sup>) were protected from herbivores and nine 25x25 cm<sup>2</sup> sub-plots were submitted to defoliation treatments for two months (May-June 2004). Defoliation treatments consisted of no defoliation, low-frequency defoliation (two defoliations) and high-frequency defoliation (four defoliations). Defoliation was performed by cutting the biomass at six cm above the soil. Primary productivity was calculated as the sum of the harvests plus the final biomass. Plant quality was estimated by the C/N ratio of the aboveground final biomass. The biomass cut at the beginning of the experiment was not included in the calculations of productivity.

## Results and discussion

The whole patch showed decreased C/N ratio of the aboveground final biomass for defoliated compared to undefoliated treatments and this decrease was significant for M patches ( $p < 0.01$ ) (Table 2). Defoliation thus enhanced plant quality and influenced plant production. The impact of defoliation on plant production differed however amongst the plant patches depending on the previous grazing regime and on the plant community (Table 2).

Considering the mesophilous plant community, Plant production was significantly decreased by defoliation ( $p < 0.01$ ) and this decrease was greater for higher defoliation frequency. This result is consistent with the work of Ferraro and Oesterheld (2002) who concluded that the negative impact of defoliation on plant production increases with defoliation frequency. We found that the negative impact of defoliation on production was less marked in the case of the M2 patch, previously intensively grazed, than in the previously ungrazed patch (M0).

Production from the defoliated M2 patch was nearly equal to undefoliated production while defoliation greatly decreased production of the M0 patch (Figure 1). Our results support the hypothesis that, in the mesophilous plant community, grazing led to the establishment of a grazing-tolerant vegetation with good ability to regrow under grazing.

Table 2. Aboveground primary production (g DM m<sup>-2</sup> d<sup>-1</sup>), and aboveground final biomass C/N ratio. For each community, the effects of the previous grazing regime and defoliation treatment on ANPP and C/N ratio were tested with two-way ANOVA analysis.

Previous grazing regime	Defoliation treatment	M		Mh	
		APP	C/N	APP	C/N
0-ungrazed	Undefoliated	3.46	19.95	3.57	26.61
	Low freq.	1.84	15.88	4.30	21.39
	High freq.	1.28	15.80	3.52	23.07
1-lightly grazed	Undefoliated	3.96	20.68	2.57	24.84
	Low freq.	3.03	19.21	5.14	21.18
	High freq.	2.54	17.29	3.34	21.83
2-intensively grazed	Undefoliated	3.39	21.16	1.78	21.54
	Low freq.	3.23	18.99	2.20	21.50
	High freq.	2.51	19.70	1.32	23.10
Grazing		*	*	***	NS
Defoliation		**	**	*	NS
Grazing*defoliation		NS	NS	NS	NS

\*\*\*: P<0.001, \*\*:P<0.01, \*:P<0.05 and NS: non significant.

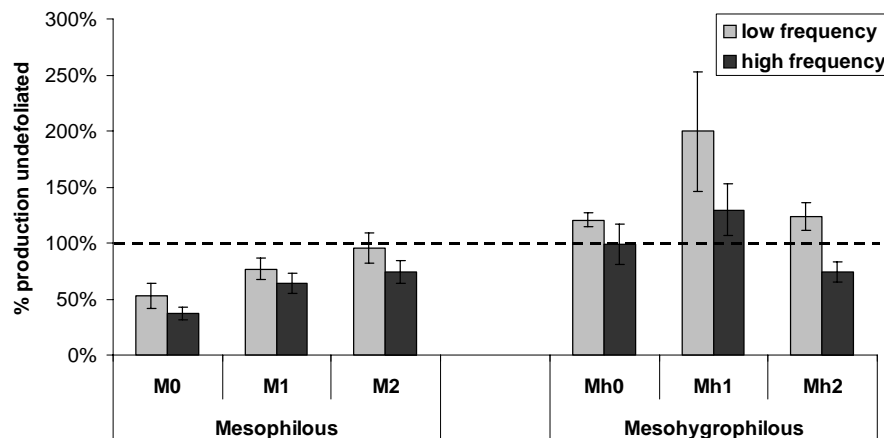

Figure 1. Aboveground production of the defoliated patches (% of undefoliated production ± SE) within the mesophilous and meso-hygrophilous communities.

Within the mesohygrophilous community, plant production was significantly affected by defoliation (p<0.05). But, in contrast to the results obtained within the mesophilous community, the low defoliation frequency enhanced plant production of the three patches (post-hoc Fisher's test) while higher defoliation frequency effects ranged from negative to positive depending on the patches. The positive effect of the low defoliation frequency was the highest in the case of the Mh1 patch, previously grazed at low intensity (Figure 1). Positive effects of defoliation on plant production were predicted to be more likely to occur at low intensity of defoliation (Dyer *et al.* 1993). Although Ferraro and Oesterheld (2002) stated that the impact of defoliation on plant production is generally negative, they observed that the impact of grazing is less negative than the impact of defoliation in controlled conditions. In our study, grazing was shown to stimulate N cycling (Rossignol *et al.* 2006). This increase of nutrient availability for grazed vegetation could then allow increased plant N uptake and increased growth rate. However, the previously intensively-grazed patch didn't show better

ability to regrow after defoliation than the previously-ungrazed patch (Figure 1). The low productivity of the intensively-grazed patch, associated with the observed occurrence of more frequent prostrate growth-forms suggested a grazing-avoidance strategy of this patch.

## Conclusion

Our study showed different patterns of response to defoliation frequency between the two plant communities occurring within the grassland. Floristic changes driven by long-term grazing patterns appeared to be of major importance in explaining the impact of grazing intensity on grassland productivity. In the mesophilous community, the establishment of a vegetation with a good ability to regrow after defoliation could lead to a neutral effect of grazing on the total production of the community. In contrast, floristic changes in the meso-hygrophilous community led to a decrease in the productivity of the vegetation. This decrease was compensated by the plant responses to defoliation in the lightly-grazed patch but not in the intensively-grazed one.

## References

- Bonis A., Rossignol N., Loucugaray G. and Bouzillé J.-B. (2005) Herbivore-driven spatial vegetation heterogeneity: consequence for forage quality, production and biodiversity in wet grasslands. In: Lillak R., Viiralt R., Linke A. and Geherman V. (eds) *Grassland Science in Europe*, vol. 10. EGS, Tartu, 247-250.
- del-Val E. and Crawley M. J. (2005) Are grazing increaser species better tolerators than decreasers? An experimental assessment of defoliation tolerance in eight British grassland species. *Journal of Ecology* 93, 1005-1016.
- Dyer M. I., Turner C. L. and Seastedt T. R. (1993) Herbivory and its consequences. *Ecological Applications*, 3, 10-16.
- Ferraro D. O. and Oesterheld M. (2002) Effect of defoliation on grass growth. A quantitative review. *Oikos*, 98, 125-133.
- Loucugaray G., Bonis A. and Bouzillé J.-B. (2004) Effects of grazing by horses and / or cattle on the diversity of coastal grasslands in western France. *Biological Conservation*, 116, 59-71.
- Milchunas D. G. and Lauenroth W. K. (1993) Quantitative effects of grazing on vegetation and soils over a global range of environments. *Ecological Monographs*, 63, 327-366.
- Milchunas D. G., Varnamkasti A. S., Lauenroth W. K. and Goetz H. (1995) Forage quality in relation to long-term grazing history, current-year defoliation, and water resource. *Oecologia*, 101, 366-374.
- Rossignol N., Bonis A. and Bouzillé J.-B. (2006) Consequence of grazing pattern and vegetation structure on the spatial variations of net N mineralisation in a wet grassland. *Applied Soil Ecology*, 31, 62-72.

# Evaluation of red clover yield in monoculture and in mixture with grasses and its comparison with grasses on arable land

Hejduk Stanislav<sup>1</sup>, Macháč Radek<sup>2</sup> and Pelikán Jan<sup>3</sup>

<sup>1</sup>*Mendel University of Agriculture and Forestry in Brně, Department of Animal Nutrition  
Grassland Management and Forage Production, Czech Republic*

<sup>2</sup>*OSEVA PRO, Ltd., Grassland Research Station Rožnov-Zubří, Czech Republic*

<sup>3</sup>*Research Institute of Fodder Crops, Ltd. Troubsko, Czech Republic*

## Abstract

Red clover is the most important forage legume in the Czech Republic. It is an unassuming species to climatic and soil condition, is suitable for mixtures with grasses and it is superior to other grassland species in forage quality.

Forage performance, persistence and competitive ability of red clover and selected grasses are verified under different soil and climatic conditions (3 sites) in two years. Red clover (7 varieties) is tested in monoculture and in mixture with 30% of grass. Varieties of perennial ryegrass (20 varieties), meadow fescue (10), timothy (5) and orchard grass (8) were being tested in continuous cropping.

The most yielding variety of red clover was Cyklon. Considerable differences were also found among the three sites. The highest forage production was realized from site on fertile chernozem with lower sum of precipitation and with higher temperatures. Conversely, the grass species production in this site was the lowest. Under Central European conditions, the pure grasses on arable land cannot be competitive in production to red clover, neither at a nitrogen fertilization level of 140 – 160 kg.ha<sup>-1</sup>. Probably frequent periods without precipitations, when growth of grasses with shallow root is restricted by drought, can be the explanation for this. Nevertheless, the clover-grass mixtures give the best yields in all conditions.

## Introduction

Red clover has been grown in the area of the Czech Republic for more than 200 years. This crop provides forage for cattle and it is utilised to increase soil fertility. But the area of perennial legumes is decreasing all over the world. According to Rochon *et al.* (2004), the area of perennial legumes in Europe decreased from 9.5 mil. ha in 1980 to 6.0 mil. ha in 2000. The reason for the decline of the red clover acreage in last 50 years is partly due to the regression of the classic crop rotation and partly in the better price of mineral nitrogen fertilizers (Taylor *et al.* Queesenberry, 1996). Grasses have number of advantages compared to legumes: faster growth, higher yield, lesser sensibility to low temperatures and too wet soil conditions.

Red clover is the most important legume in the Czech Republic, looking on seed consumption. In the business year 2005/06, 513.1 t of red clover seed on 4290 ha were produced (Fránová, 2006). The area of monocultures on arable land is smaller than lucerne, but in contrast to lucerne, red clover is used in short-time and temporary clover-grass mixtures. Red clover improves the quality of grass forages (high CP content and digestibility) and satisfactory supports the sward with nitrogen by symbiotic rhizobium fixation. This nitrogen is progressively available to companion grasses. Total amount of fixed nitrogen in red clover monocultures is the same as in red clover-grass mixtures.

In 70's the tetraploid varieties were introduced to praxis, they are characterised by slower maturing and higher fresh forage yield and exceed diploids in persistency (Jamriška *et al.*, 1998).

In the Czech Republic, red clover is also used for oversowing of permanent meadows and high productive (dairy) pastures. Even though at a low level of nitrogen fertilization, red clover significantly increases the forage yield and quality. The greatest problem of red clover in permanent grasslands is its lack of persistency; it is only 2 - 4 years crop (Hejduk, 2006).

## Materials and methods

The trial was established in spring 2004 in three localities with different climatic and soil conditions (see Table 1).

Table 1. Short characteristics of experimental sites

Locality	Altitude	Average temp.	Precipitations	Soil
Vatín	540 m	6,1 °C	736 mm	Acid Cambisol
Rožnov – Zubří	345 m	7,6 °C	903 mm	Cambisol doplň
Troubsko	270 m	8,4 °C	537 mm	Chernozem

The swards were sown with 20.0 kg ha<sup>-1</sup> of red clover in monoculture; for the clover-grass mixture 14.0 kg ha<sup>-1</sup> of clover was used (the same varieties as in monoculture) with 4.5 kg ha<sup>-1</sup> timothy (*Phleum pratense*) and 4.5 kg ha<sup>-1</sup> meadow fescue (*Festuca pratensis*).

7 varieties of red clover were tested. The following grasses were sown at the same time: *Phleum pratense* (5 varieties), *Festuca pratensis* (10), *Dactylis glomerata* (8), *Lolium perenne* (20). These grasses were cut 3 times per year, perennial ryegrass 5 times.

The monocultures of clover were not fertilised with nitrogen, the mixtures were fertilised with 30 kg N ha<sup>-1</sup> and grasses were fertilised with 140 kg N ha<sup>-1</sup> (3 cuts) or with 160 kg N ha<sup>-1</sup>. P and K were dosed in autumn according to the soil nutrient status (25 kg P and 33 kg K).

The plots had an area of 10 m<sup>2</sup> and each variant had 3 repetitions. The following characteristics were determined: fresh and dry forage yield, height of the swards before each harvest, share of weeds and empty places and diseases occurrence. In mixtures, the share of the variety (species) was measured.

## Results and discussion

When we compare the production of individual red clover varieties, the tetraploid variety Cyklon reaches the best results during two years. Because of different dry matter contents in, the ranking in fresh and dry matter is not the same. The only diploid variety Tábor was the worst in fresh yield, but showed a higher dry matter production (dry matter content is of 1 – 2% higher in diploids). The most widely known variety Kvara does not belong any more to the top varieties anymore.



Table 2. Yield characteristic of red clover varieties during two years (2005 and 2006; sowing year 2004)

Variety	Fresh forage yield (t ha <sup>-1</sup> )					Dry matter yield (t ha <sup>-1</sup> )				
	Locality					Locality				
monoculture	Troubsko	Zubří	Vatín	Aver.	stat.	Troubsko	Zubří	Vatín	Aver.	stat.
1 Cyklon	158,5	139,5	151,3	149,8	A	28,6	26,2	25,1	26,6	A
2 Dolly	161,2	124,9	152,9	146,3	ABC	28,9	23,3	25,2	25,8	AB
3 Vulkán	161,9	129,1	151,7	147,6	AB	27,9	23,3	24,0	25,1	ABC
4 Dolina	151,2	124,9	132,6	136,2	BCD	28,3	24,8	23,0	25,4	AB
5 Kvarta	136,2	112,1	114,9	121,0	E	25,6	23,0	20,9	23,1	BC
Radegas										
6 t	140,4	111,5	125,2	125,7	DE	24,7	20,7	22,3	22,6	C
7 Tábor	130,1	117,7	104,5	117,4	E	26,4	25,5	19,5	23,8	BC
100%=	148,5	122,8	133,3	t ha <sup>-1</sup>		27,19	23,81	22,87	t ha <sup>-1</sup>	
clover-grass	Troubsko	Zubří	Vatín	Aver.	stat.	Troubsko	Zubří	Vatín	Aver.	stat.
1 Cyklon	157,3	131,0	148,3	145,5	ABC	30,6	25,0	29,7	28,4	A
2 Dolly	163,0	136,9	148,9	149,6	A	31,1	25,7	28,0	28,3	AB
3 Vulkán	157,1	128,4	152,2	145,9	AB	29,6	24,6	28,0	27,4	ABC
4 Dolina	150,5	121,6	134,0	135,3	DE	29,4	24,3	26,2	26,6	BC
5 Kvarta	135,9	112,3	124,4	124,2	E	27,8	25,2	24,3	25,8	C
Radegas										
6 t	154,4	133,6	138,0	142,0	BC	30,5	25,4	28,4	28,1	AB
7 Tábor	137,5	118,1	128,0	127,9	E	29,6	24,9	28,2	27,6	AB
100%=	150,8	126,0	139,1	t ha <sup>-1</sup>		29,82	25,01	27,55	t ha <sup>-1</sup>	

Differences were not only found among the evaluated varieties, but also among the three sites. The highest forage production was realized in Troubsko on fertile chernozem with lower sum of precipitation and with higher temperatures (see table 2 and 3). Conversely, the grass species forage production in this site was the lowest. The results in table 2 confirm, that under Central European conditions, the pure grasses on arable land cannot be competitive in production to red clover, neither at a nitrogen fertilization level of 140 – 160 kg ha<sup>-1</sup>. The reason is probably that frequent periods without precipitations (drought), restrict the shallow root growth.

Table 3. Dry mater production (t.ha<sup>-1</sup>) of selected perennial forages in two years in three sites

Forage	2005				2006			
	T	Z	V	Aver.	T	Z	V	Aver.
Red clover	18,4	14,3	11,2	14,6	16,5	9,5	11,7	12,5
Clover-grass mix.	20,3	14,9	14,1	16,4	16,7	10,1	13,5	13,4
Timothy	11,0	13,5	12,2	12,2	7,4	14,4	10,8	10,9
Meadow fescue	8,8	10,6	13,2	10,8	5,9	12,6	9,6	9,4
Cocksfoot	11,2	24,3	14,1	16,5	8,8	15,0	8,1	10,6
Perennial ryegrass	7,1	11,0	9,5	9,2	5,6	9,0	8,1	7,6

T, Z and V = individual sites Troubsko, Zubří and Vatín

The results in table 4 show a markedly different production potential of individual perennial forage species, depending on soil and climatic conditions.

Table 4. Correlation between sum of precipitation and average temperature during vegetation period (2 years, three sites)

Agent	red clover	clover-grass mixture	timothy	cocksfoot	meadow fescue	perennial ryegrass
Temperature	0,59	0,49	-0,45	-0,20	-0,60	-0,65
Precipitation	-0,72	-0,84	0,76	0,45	0,57	0,53

Red clover provides the highest forage production in fertile and deep soils with smaller amount of precipitation due to deep tap roots. Conversely, in these conditions, the grass yields are lower than on shallow less fertile soils with higher sum of precipitation. Nevertheless, the clover-grass mixtures give the best yields in all conditions.

## Conclusions

Red clover is the most important forage legume in the Central Europe. Although it is grown most frequently on less fertile soils in higher altitudes, the highest forage production was reached on fertile and deep soils with smaller amount of precipitation. Due its deep tap roots, red clover is not dependent on regularly precipitations as grasses.

On the other hand, the grass species production of forage was the lowest on the chernozem site. Under Central European conditions, the pure grasses on arable land cannot be competitive in production to red clover, neither at a nitrogen fertilization level of 140 – 160 kg ha<sup>-1</sup>. Probably frequent periods without precipitations, when growth of grasses with shallow root is restricted by drought, can be the explanation for this. Nevertheless, the clover-grass mixtures give better yields in all conditions than pure grass or red clover swards.

## Acknowledgement

Result achieved were obtained and processed under the financial support of the Czech Ministry of Agriculture (NAZV), Research Plan No. QF4034.

## References

- Beare M.H., Curtin D., Fraser P.M. and Francis G.S. (2005) Chemical components and effects on soil quality in temperate grazed pasture systems. In: Jarvis, S.C., Murray, P.J., Roker, J.A. eds., *Optimisation of nutrient cycling and soil quality for sustainable grasslands* Proceedings of a satellite workshop of the XX<sup>th</sup> International Grassland congress, July 2005, Oxford, England, 25-36.
- Fránová S. (2006) Rozsah uznávacího řízení v ČR v roce 2005. ÚKZÚZ, písemné sdělení
- Hejduk S. (2006) The Persistency Evaluation of Czech Varieties of Red (*Trifolium pratense* L.) and Alsike Clover (*Trifolium hybridum* L.) Acta Universitatis Agriculturae et Silviculturae Mendelianae Brunensis, 54 (4), 133-138. (text in Czech)
- Jamriška P., Surovčík, J. and Zubal P. (1998) Growing of Perennial Legumes. *Výskumný Ústav Rastlinej Výroby Piešťany*, 67 p. (text in Slovak)
- Taylor N.L. and Queensberry K.H. (1996) Red Clover Science. *Kluwer Academic Publishers*, 226 p.

# Forage quality dynamics and productivity of fodder galega-grass swards

Adamovich A. and Adamovicha O.

*Latvia University of Agriculture, 2 Liela iela, Jelgava, Latvia, LV-3001*

## Abstract

Field trials (1986 - 2006) were carried out with the aim to study continuous green forage production from fodder galega-grass swards in the stage of intensive growth. The 30 mixed binary and multi-species swards were developed on Stagnic Luvisol and were fertilized with either 0 N or 90 kg N ha<sup>-1</sup>. The swards were composed of fodder galega (*Galega orientalis* Lam.) 'Gale' and thirteen grass species. Swards were cut two to four times during the growing season. Fodder galega in mixtures with grass of various growth patterns provided continuous green forage production during the whole summer season. The botanical composition and frequency of cutting affected the average productivity of a sward (6.16 to 11.0 t ha<sup>-1</sup> DM). The average content of net energy of lactation (NEL) of fodder galegas was 5.47-5.68 MJ kg<sup>-1</sup> DM. In mixed galega-grass stands it was 5.67 – 6.18 MJ kg<sup>-1</sup> DM. The swards receiving no fertilizer N were more productive and of high quality.

Key words: fodder galega, grass, mixtures, productivity, quality

## Introduction

Alfalfa and white clover are traditional forage crops in Latvia. Their sown area ranks in second place after red clover. In Latvian agricultural practice, fodder galega (*Galega orientalis* Lam.) is grown for a relatively short period. Recently introduced into Latvia, it is rousing ever-growing interest due to its persistency and high yielding ability.

Experiments on fodder galega show that this longlived legume survives in pure stands for 25 and more years and provides annual DM yields from 9.56 to 11.0 t ha<sup>-1</sup> (Adamovich, 2000, 2006; Driķis, 1995; Šlepetys, 2000). Pure fodder galega stands, compared to other legumes, are not thinning out during harvest years providing stable yields of green feed and seeds. Successful action of nodule bacteria is resulting in fixed atmospheric nitrogen from 200 to 453 kg ha<sup>-1</sup> (Driķis, 1995) thus eliminating the need to apply nitrogen as commercial fertilizer. The use of the symbiotic potential of fodder galega grown in mixtures with grass contributes to the production of ecologically safe forage and animal products.

The main aim of this study was to examine the optimum productivity of fodder galega/grass swards and determine the implications of the of cutting regime for the quality of forage.

## Materials and methods

In 1978, cultivation and research on fodder galega was started at Latvia University of Agriculture. Expensive field experiments were conducted during a 20 years period (1986-2006). They were carried out with the aim to study continuous green forage production from fodder galega-grass swards in the stage of intensive growth.

The 35 mixed (13 binary and 22 multi – species) swards were developed on stagnic – luvisol (pH<sub>KCl</sub> was 6.7, mobile P 52 and K 128 mg kg<sup>-1</sup> of soil). Pure swards, binary- and multi-species seed mixtures were composed of fodder galega cv. 'Gale' and 13 grass species:

*Alopecurus pratensis*, *Arrhenatherum elatius*, *Bromus inermis*, *Dactylis glomerata*, *Festuca pratensis*, *Festuca rubra*, *Festuca arundinacea*, *Phleum pratense*, *Lolium perenne*, *Phalaris arundinacea*, *Agrostis gigantea*, *Poa pratensis* and *Poa palustris*. Stands were sown in early May in 1980, 1986, 1990 and 1997. The total seeding rate was 1000 germinating seeds m<sup>-2</sup>. The ratio of fodder galega-grass seeds in 13 binary mixtures (1986) was 50:50. In all experiment series (1990 and 1997) the mixture contained 40% fodder galega and 60% grass seeds: 7 binary mixtures 40:60, 14 three – component mixtures 40:30:30, 5 four – component mixture 40:20:20:20, 1 five – component mixtures 40:15:15:15:15 and 2 six - component mixtures 40:12:12:12:12:12. The plots were fertilised with 40 kg P<sub>2</sub>O<sub>5</sub> /ha and 150 kg K<sub>2</sub>O ha<sup>-1</sup> and without or with N90 kg ha<sup>-1</sup> in 2 equal dressings. Swards were cut two to four times during the growing season. The plot size was 14 to 20 m<sup>2</sup>. Meteorological conditions greatly differed during the experimental period.

The botanical composition of the sward was determined at each cut for all treatments. The chemical composition of plants was determined only for the first cut by the following methods: dry matter (DM) – drying; crude protein (CP) – modified Kjeldahl; crude fibre (CF), neutral detergent fibre (NDF), acid detergent fibre (ADF) and nett energy of lactation (NEL) – Van Soest (1980); *in vitro* digestibility of the organic matter (IVOMD) – De Boever *et al.*(1994).

## Results and discussion

Without reseeding, in 25 production years of pure galega, the following average yields of DM and CP were obtained at early flowering: 8.97 t ha<sup>-1</sup> DM and 1.94 t ha<sup>-1</sup> CP on stagnic luvisol in a two-cutting management (Fig. 1).

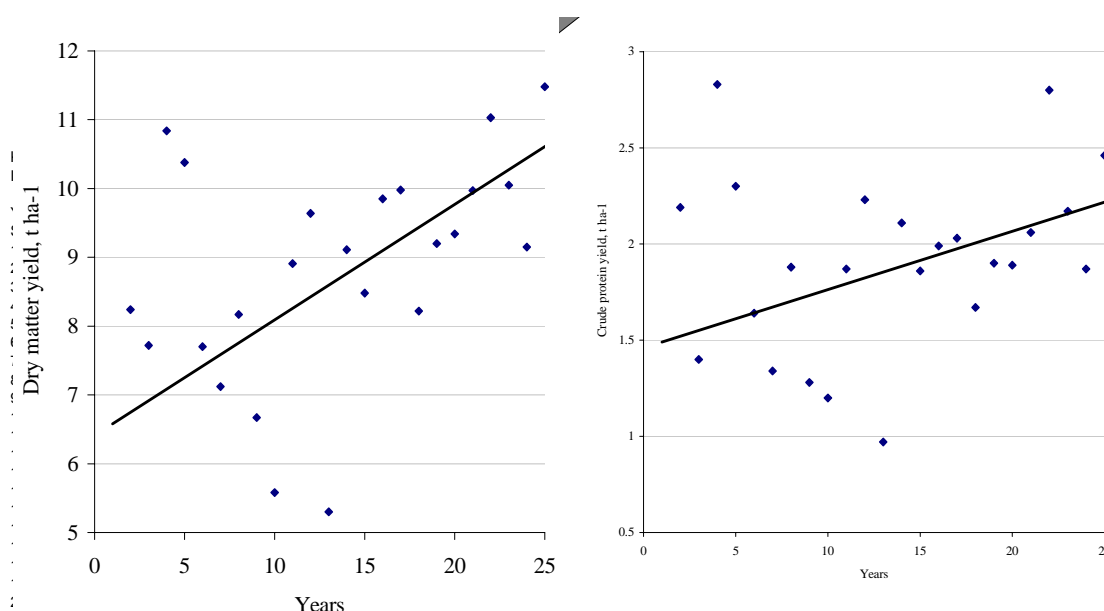

Fig.1. Dry matter and crude protein yields of fodder galega, t ha<sup>-1</sup> (1981-2005)

Fodder galega significantly surpassed other forage legumes in respect to productive longevity, and fluctuations in DM yield were insignificant between years of use. Inclusion of a grass species in a mixture resulted in yield increase by 28 to 36% already in the first production year. Split application of the 90 kg N fertiliser negatively affected the proportion of galega in a sward resulting in the decrease of DM yields by 1.04 t ha<sup>-1</sup> at two cutting management, compared to unfertilized plots. Frequently cutting (four times) had a declining effect on the

productivity of galega-grass mixtures. The total yield of DM decreased by 3.34 t ha<sup>-1</sup> or 35.2% in all experimental plots at a four-cutting management. **Significant** (P>95%) changes were observed in the productivity of galega-grass swards in all treatments, depending on N-fertilizer and frequency of cutting (Table 1).

Table 1. Dry matter yields of fodder galega/grass swards, t ha<sup>-1</sup> (1998-2006, nine production years on average)

Cutting frequency (F <sub>A</sub> )	Nitrogen fertilizer, kg ha <sup>-1</sup> (F <sub>B</sub> )	Composition of swards (F <sub>C</sub> )							Average (F <sub>A</sub> ) LSD <sub>0,05</sub> = 0.32	Average (F <sub>B</sub> ) LSD <sub>0,05</sub> = 0.21
		fodder galega	number of components in mixtures							
			two	three	four	five	six	Average		
Two - fold	N 0	9.70	9.92	11.07	10.26	9.80	10.12	10.14	9.50	8.35
	N 90	8.74	8.86	9.27	9.14	8.67	8.46	8.86		
Four - fold	N 0	6.48	6.82	7.24	6.63	6.26	5.96	6.56	6.16	7.31
	N 90	6.35	5.45	6.81	5.77	5.02	5.14	5.76		
Average (F <sub>C</sub> )			7.82	7.76	8.60	7.95	7.74	7.42	7.83	
LSD <sub>0,05</sub> = 0.19										
Trial LSD <sub>0,05</sub> =0.43										

In 9 production years average yields of dry matter and crude protein of pure galega stands obtained in the bud stage amounted to 9.50 t ha<sup>-1</sup> DM and 1.84 t ha<sup>-1</sup> CP at a two-cutting management and 6.16 t ha<sup>-1</sup> DM and 1.31 t ha<sup>-1</sup> CP at a four-cutting management respectively. Receiving no fertilizer N, highly productive binary and three species galega-grass swards were developed providing the following average yields of DM and CP - 9.80 t ha<sup>-1</sup> DM and 1.82 t ha<sup>-1</sup> CP at two- fold cutting treatments, and 6.56 t ha<sup>-1</sup> DM and 1.47 t ha<sup>-1</sup> CP at four- fold cutting regime.

The productivity of binary fodder galega-grass swards was the following: the average yield 9.92 t ha<sup>-1</sup> DM in swards receiving no fertiliser N, and 8.86 t ha<sup>-1</sup> DM in swards splitting the fertiliser into two applications at the beginning of the growing season and after cut 1. Fodder galega-grass swards contributed to the crop yield and made N available to the companion grasses. Depending on the cutting regime, highly productive binary swards were developed when growing fodder galega in association with *Arrhenatherum elatius*, *Dactylis glomerata*, *Festuca arundinacea*, *Phleum pratense* and *Lolium perenne*. In the first production years the companion grass, such as *Dactylis glomerata*, *Festuca arundinacea*, *Lolium perenne*, contributed to the total yield of the sward. The proportion of creeping grass, such as *Alopecurus pratensis*, *Bromus inermis*, *Phalaris arundinacea*, *Agrostis alba*, *Festuca rubra*, *Poa pratensis*, increased in 3rd, 4th and 5th production years.

Most productive fodder galega-grass mixtures were composed of three species providing the following average yields: 10.7512.36 t ha<sup>-1</sup> DM and 1.982.34 t ha<sup>-1</sup> CP. At three-fold cutting regime, three-component mixed swards excelled with CP and DM yields providing 1.86 and 10.01 t ha<sup>-1</sup>, respectively. The crop yield level in a sward was not significantly affected by the increase of the number of the species from 4 to 6 in a sward, compared to binary and three species mixed swards, but it ensured, stability of yields between production years.

The chemical composition and nutritive value dynamic of fodder galega were studied (Table 2). In branching and bud stages fodder galega excelled with high crude protein contents, 279 g kg<sup>-1</sup> DM. In mixed swards the CP content decreased to 253 g kg<sup>-1</sup> DM in the bud stage; at early flowering the average CP content was 226 g kg<sup>-1</sup> DM. This could be explained by the great proportion of plant leaves accounting for 536 ± 42g kg<sup>-1</sup> DM in the fodder galega yield.

The fixed atmospheric nitrogen fully met the demands necessary for the development of fodder galega and contributed to the growth of associate grasses in the swards receiving no mineral fertiliser N. The average content of nett energy of lactation (NEL) was 5.47-5.68 MJ kg<sup>-1</sup> DM of fodder galega, in mixed galegagrass stands it was 5.67 – 6.18 MJ kg<sup>-1</sup> DM (Table 2).

Table 2. Chemical composition and nutritive value dynamic of fodder galega/grass forage (mean of 5 full harvest years)

Stages of growth	Crude protein, g kg <sup>-1</sup> DM	NDF, G kg <sup>-1</sup> DM	ADF, g kg <sup>-1</sup> DM	NEL, MJ kg <sup>-1</sup> DM	IVOMD, %
Fodder galega in pure stands					
Stems branching	281.3	320.4	245.4	6.72	74.0
Bud beginning:					
whole plant	276.7	335.4	376.4	5.68	70.0
leaves	346.5	387.8	262.8	6.56	77.3
stems	232.8	476.2	368.3	5.37	59.6
Early bloom	257.2	511.7	393.8	5.47	63.0
Full bloom	218.4	527.4	428.4	5.23	58.2
Fodder galega / grass mixtures					
Stems branching	252.6	324.6	235.0	6.73	76.0
Bud beginning	226.0	367.9	276.4	6.18	71.2
Early bloom	202.0	487.5	369.5	5.67	65.0
Full bloom	173.3	552.8	399.7	5.42	61.0

Literature findings (Driķis, 1995; Moller, Hostrup, 1996) indicate that there is a rapid increase of the CF content, including NDF and ADF fractions when cutting fodder galega in early bloom and later. Our studies showed that in mixtures with grasses the average NDF content did not exceed 488 g kg<sup>-1</sup> DM, compared to NDF content 512 g kg<sup>-1</sup> DM in pure galega stands in early bloom. The average organic matter digestibility of pure galega stands harvested at early flowering was 63%, and in mixtures 65 percent. It is characteristic that digestibility of the fodder declines with maintenance of high protein content in dry matter even in full bloom.

## Conclusions

Fodder galega in pure stands or in mixtures with grass of various growth patterns is productive, of high quality and persists for long periods. Three species mixtures proved to be most productive. Competitive grasses in the mixtures reduce productive longevity of swards compared to pure galega stands. Dry matter of fodder galega has a high content of crude protein with a high concentration of non-replaceable amino acids.

## References

- Adamovich A. and Auzins V. (2006) Productivity, persistence and forage quality of fodder galega. *Bibliotheca Fragmenta Agronomica*, 11, (1), 25-26. .
- Adamovich A. (2000) Productive longevity of Fodder galega-grass sward / Grassland Farming. Balancing environmental and economic demands. *Grassland Science in Europe*, 5, 100-103.
- Driķis J. (1995) Fodder galega and alfalfa grown in pure stands and in mixtures, their yielding capacity and yield quality. Jelgava, 84.
- Moller E. and Hostrup S.B. (1996) Digestibility and feeding value of fodder galega (*Galega orientalis* Lam.) *Acta Agriculturae Scandinavica*. Section A-Animals Science, 46, (2), 97-104.
- Raig H. (1994) Advances in the research of the new fodder crop *Galega orientalis* Lam. Fodder galega (*Galega orientalis* Lam.) research in Estonia. Saku, 524.
- Šlepetys J. (2000) Fodder galega (*Galega orientalis* Lam.) is a valuable forage herb for organic farming/ Grassland Farming. Balancing environmental and economic demands. *Grasslands Science in Europe*, Denmark, 5, 536.-538.

# Research regarding the contribution of *Lotus corniculatus* L. to the increase of temporary grassland production and quality

Dragomir N., Pet I., Dragomir C., Pet E., Gaspar S., Mihaescu L., Sarbu A., Gaman L. and Fratila I.

University of Agricultural Sciences, USAMVB, 300645 Timisoara, Romania

## Abstract

This research work emphasizes the contribution of *Lotus corniculatus* to the increase of production and its quality in temporary meadows. The experimental conditions extended upon a trial of many factors, carried out on an eumezobasic, intensively gleyed, silty brown soil with a pH of 5.6. The results obtained prove the contribution of *Lotus corniculatus*, mixed with various perennial gramineous, to the gain in dry matter production. Applying more than 100 kg N ha<sup>-1</sup> on a mixture with 30/40% *Lotus corniculatus* resulted in an insignificant and small increase of the yield. In a mixture of *Lotus corniculatus* and grasses, a production, 1432-1883 kg/ha crude protein is realized, depending on the level of N-fertilisation. The birdsfoot trefoil contribution in nitrogen supply of meadows is reflected by the total amount of nitrogen contained in the biomass produced which, in the conditions studied, amounts 128 kg/ha. In this sense, each per cent of *Lotus corniculatus* participation in the medley corresponds with a quantity of 2.78 kg/ha nitrogen, depending on the factor taken into study.

Keywords: temporary grassland, contribution of *Lotus corniculatus*, nitrogen

## Introduction

Within the floristic structure of permanent and temporary pastures, located in areas with soils having a low natural fertility, the presence of birdsfoot trefoil can play an important role in dry matter production and quality (Dragomir *et al.*, 1992; Dale E, Farnham, J.R. George, 1994).

The leguminous species transfer a big part of the biological nitrogen fixed to the accompanying species, contributing in this way to the provision of pastures with symbiotically-fixed nitrogen (West and Wedin, 1985; Mallarino *et al.*, 1990; Elgersma and Schepers, 2001). Birdsfoot trefoil's capacity of fixing nitrogen depends upon the genotype, and natural and technological conditions. Furthermore, research performed by Heichel *et al.* (1985) highlighted that this leguminous fix annually about 60-120 kg N ha<sup>-1</sup>. (Razec *et al.*, 2001) reported that, each percentage of participation of birdsfoot trefoil in a temporary pasture 4 kg ha<sup>-1</sup> biological nitrogen.

The study intends to evaluate the contribution of birdsfoot trefoil to the increase of yield and quality in temporary grasses and the effect on N-fixation.

## Materials and methods

Researches has been done during three years at the Station of Research-Development for Pastures Timisoara, in South-West of Romania, under the conditions of an acid soil (pH = 5.60), slightly supplied with nutritive elements. The experience was a poly-factorial one, with the following graduations: A = gramineae way of cultivation (a<sub>1</sub> = pure crop; a<sub>2</sub> = crop mixed with birdsfoot trefoil); B = doses of nitrogen-based fertilization (N<sub>0</sub>, N<sub>50</sub>, N<sub>100</sub>, N<sub>200</sub>). The following and varieties were used: birdsfoot trefoil, var. Nico; orchard fescue (*Festuca*

*pratensis*), var Tâmpa; perennial ryegrass (*Lolium perenne*), var. Marta. Mixtures` floristic structure had an equal sowing proportion of birdsfoot trefoil and gramineae species. The surface of each experimental parcel was  $2 \times 7 = 14 \text{ m}^2$ . Every year, we determined: dry matter and crude protein yield, floristic composition`s evolution; N-exportation; estimated quantity of fixed nitrogen and birdsfoot trefoil`s contribution to the provision of temporary pastures with biological nitrogen. This work presents the mean values achieved during the experimental years.

## Results and discussion

Birdsfoot trefoil has an important contribution for the increase of dry matter in temporary pastures. So, the mixture crop of birdsfoot trefoil and perennial gramineae (*Festuca pratensis* or *Lolium perenne*) leads to an increase of yield with 30-50% compared to the perennial gramineae crop. Under the conditions provided by the nitrogen dose  $N_{100}$ , we have obtained a dry matter yield of only  $6.3 \text{ t ha}^{-1}$  in pure gramineae crop and  $9.6 \text{ t ha}^{-1}$  in the mixture crop of gramineae and birdsfoot trefoil. For this fertilization variant, we have also performed the optimal proportion of birdsfoot trefoil participation within the floristic structure (55%). If we apply bigger quantities of nitrogen-based fertilizers (over  $N_{200}$ ), then we may achieve a reduction of the yield difference between the two cultivation variants and, at the same time, a decrease of the birdsfoot trefoil`s participation amount.

Birdsfoot trefoil`s contribution was also assessed through the crude protein yield an increase from  $960 \text{ kg ha}^{-1}$  in the gramineae crop to  $1817 \text{ kg ha}^{-1}$ , in the mixture birdsfoot trefoil, gramineae (+ 89%, for  $N_{100}$ ). The application of more nitrogen leads to the same tendency of remarkable decrease, like in the dry matter yield, due to the decrease of the percentage birdsfoot trefoil within ther mixture (Figure 1).

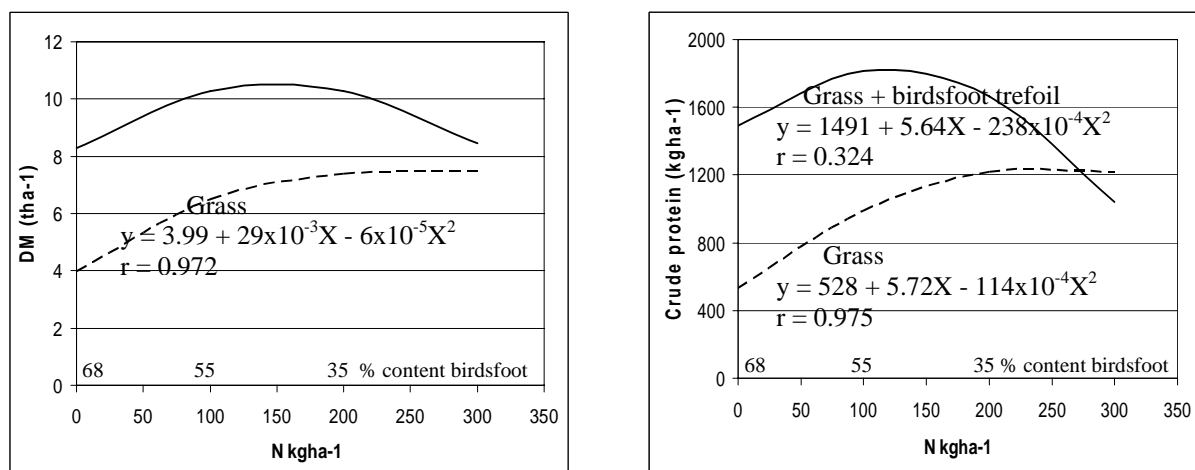

Figure 1. Possibilities for reducing nitrogen fertilizer requirement by cropping of birdsfoot trefoil and perennial grasses

The birdsfoot trefoil`s proportion within the mixture crop gets differentiated with the gramineae species. Concerning this aspect, studies have proved that the birdsfoot trefoil proportion is bigger in the case of the mixture with *Festuca pratensis* (with 5-10%) compared to the mixture with *Lolium perenne*, indifferently of the nitrogen dose applied. This remark may be due to the different capacity of competition exerted by the two gramineae species upon birdsfoot trefoil (Figure 2).



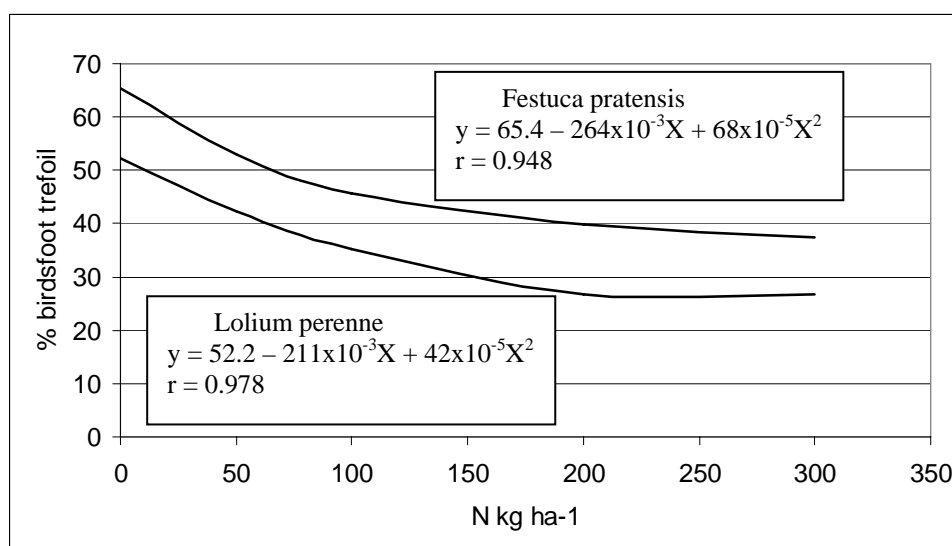

Figure 2. Relationship between nitrogen fertilization and percentage of birdsfoot participation in dependence of grass species in mixture

Table 1. Total N yield of pure grass and mixture with *Lotus c.*, and amount of N fixed per hectare and percent legume content (mean of 3 years)

Sward type	Treatment (kgN ha <sup>-1</sup> year <sup>-1</sup> )	N yield (kg ha <sup>-1</sup> )	Apparent N <sub>2</sub> fixation (kg ha <sup>-1</sup> )	Birdsfoot content (% of DM)	N <sub>2</sub> fixation (kg per % birdsfoot)
Festuca pratensis (pure grass)	0	79	-	-	-
	50	108	-	-	-
	100	151	-	-	-
	200	197	-	-	-
Festuca pratensis + Lotus corniculatus (mixture)	0	167	88	69	1.27
	50	223	115	55	2.09
	100	250	99	38	2.60
	200	279	82	24	3.41
Lolium perenne (pure grass)	0	78	-	-	-
	50	112	-	-	-
	100	157	-	-	-
	200	195	-	-	-
Lolium perenne + Lotus corniculatus (mixture)	0	146	68	67	1.01
	50	173	61	53	1.15
	100	237	80	32	2.50
	200	264	69	20	3.45

The capacity of N-fixation is a characteristic specific to leguminous species. In mixtures with temporary pastures, the leguminous species transfer important amounts of fixed nitrogen to the gramineae species. And so we can optimise the whole ecosystem of temporary pastures, because less chemical N fertilisers are used.

The results achieved regarding the balance of total nitrogen within the biomass harvested indicate that in the case of mixtures with gramineae and birdsfoot trefoil, we may achieve a total nitrogen yield of 146-279 kg ha<sup>-1</sup>, including an estimated quantity of fixed nitrogen of 61-115 kg ha<sup>-1</sup>, depending on the gramineae species, the nitrogen dose and the birdsfoot trefoil proportion within the mixture. About the level of N-fixation, we can conclude that each participation percentage of birdsfoot trefoil corresponds to a mean fixed nitrogen quantity of

2.34 kg ha<sup>-1</sup> year<sup>-1</sup>, in the case of the v *Festuca pratensis*-based mixture and 2.03 kg ha<sup>-1</sup> year, in the mixture with *Lolium perenne* (Table 1).

## Conclusions

Birdsfoot trefoil participation within mixtures with gramineae species for the achievement of temporary pastures contributes to the increase of dry matter yield with 30-50% and of crude protein with 30-90%, depending upon the birdsfoot trefoil's proportion within the floristic structure, on the partner-gramineae and on the nitrogen dose applied. Under experimental conditions, we concluded that birdsfoot trefoil fixes annually a nitrogen amount of 61-115 kg/ha, and for each percentage of participation within mixture, it leads to a quantity of fixed nitrogen of 2.03-2.34 kg ha<sup>-1</sup> year<sup>-1</sup>.

## Reference

- Dale E. Farnham and J. Ronald George (1994) Dinitrogen fixation and nitrogen transfer in birdsfoot trefoil – orchardgrass communities, *Agro. Journal*, 86, 690 – 694
- Dragomir N., Vintilescu C. and Cralov A. (1992) Cecetari privind W contributiia ghizdeiului la sporirea productiei si calitatii pajistilor temporare, *Lucr. St. I.C.P.C.P. Brasov*, vol XV, 139-150
- Elgersma A. and Schelplers H. (2001) N-use efficiency in grass-clover mixtures, *Science in Europe*, vol. 6, 73-75
- Heichel G.H., Vance P.C., Barnes K.D., Henjum J.K. (1985) Dinitrogen fixation, and N and dry matter distribution during 4 year stands of birdsfoot trefoil and red clover, *Crop Sci.*, 25, 101-105
- Mallariano A.P., Wedin W.I., Perdano R.C. and West C.P. (1980) Nitrogen transfer from white clover, red clover W and birdsfoot trefoil to associated grass, *Agro. Journal*, 82, 790-795
- Razec I., Razec Maria, Dragomir N. and Oprea G. (2001) Nitrogen fixation by *Trifolium repens* and *Lotus corniculatus* in mixtures with *Dactylis glomerata*, *Grassland Science in Europe*, vol. 6, 61-63
- West C.P. and Wedin F.W (1985) Dinitrogen fixation in alfalfa – Orchardgrass pastures, *Agro. Journal*, 77, 89-94

# Comparison of the development of two grassland legumes grown in different silt soils

Bernard F. and Fustec J.

*Plant Ecophysiology and Agroecology Lab., ESA, 55 rue Rabelais ,49007 Angers, France*

## Abstract

This research focuses on the influence of soil characteristics on the early development of four varieties of *Lotus corniculatus* and four varieties of *Trifolium hybridum*. Plants were sown in pots filled with five different silt soils collected from fields located in the west of France. They were grown in a greenhouse for nine weeks. At the end of the experiment, above ground organs were counted, measured, dried and weighed. Generally, within a species, the number of leaves and ramifications, leaf area, and dry weights did not differ between varieties. However, results differed markedly between soil types. All the birdsfoot trefoils produced many fewer leaves, ramifications and less dry matter in soil with more than 50% silt. For this species, highest yields were obtained in soils containing more than 30% sand. In soils with the highest CaO content, alsike clovers produced fewer leaves, less dry matter, and leaf area per plant was smaller than in the other soils. These preliminary results will help to direct further experiments aiming to better adapt choice of legume species to suit different silt soils.

Keywords: Birdsfoot Trefoil, Alsike Clover, development, edaphic constraints, poor soils

## Introduction

White clover, red clover and lucerne are commonly used in grassland mixtures in order to help reduce nitrogen inputs, but also to improve forage quality (Goh and Bruce 2005). However, these legume species are not well adapted to poor soils, such as silt soils commonly encountered in the west of France (in Pays-de-la-Loire). Birdsfoot trefoil (*Lotus corniculatus* L.) and alsike clover (*Trifolium hybridum* L.) are more adapted to poor agronomic conditions (Barlan *et al.*, 2002). Nonetheless, they currently play a minor role and have received little investigation in Europe, though they are recognized to be interesting forage legumes (Hopkins *et al.*, 1996). The aim of this preliminary study was to compare the early development of several varieties of birdsfoot trefoil and alsike clover grown in different kinds of silt soils, but under the same climatic and watering conditions.

## Materials and methods

Soils (A, B, C, D and E) were collected from the 20 cm upper layer of five fields located in different farms in the west of France. A sample of each soil was sent to the SAS Laboratory (FRANCE Analyse®) for textural and chemical analyses. Each soil was roughly blended to destroy bigger clods, and stones were not removed. Four varieties of birdsfoot trefoil (*L. corniculatus* L. cv. Albena, Leo, Gran san gabriele and Lotanova) and four varieties of alsike clover (*T. hybridum* L. cv. Dawn, Dixon, Buffalo and Ermo) were sown separately in 4 l pots filled with the different soils. In all pots, before sowing, 100 ml water was sprinkled onto the soil surface. For each variety and each soil ( $n = 4$ ), 12 seeds were carefully displayed and evenly distributed about a central circle drawn on the wet soil surface. The 160 pots were distributed at random on three culture tables in a greenhouse (mean temperature  $24.3^{\circ}\text{C} \pm \text{SE } 0.6$ ; mean hygrometry  $67.4\% \pm \text{SE } 1.5$ ). Throughout the experiment, they were

simultaneously watered by sub-irrigation twice a week. After the development of the first true leaf, seedlings were thinned to six plants per pot. Plants were harvested after nine weeks. For birdsfoot trefoil, the number of leaves and axes per plant were counted, and the longest axis measured. For alsike clover, the number of leaves and the maximum petiole length were recorded for each plant. The total leaf area of each plant was also measured with a planimeter. Then, above ground parts of plants of each pot were pooled and dried at 60°C before weighing. Roots were examined to make sure plants had produced nodules. For each variety within a species, we compared results obtained with the different soils using non parametric tests ( $n = 4$ ). Subsequent analyses were carried out *i*) after pooling results obtained with all varieties of a similar species grown on the same soil, or *ii*) after pooling results obtained on all soils for a particular variety.

## Results and discussion

The loams (A and B) were very similar in terms of their textural characteristics, while they differed by in their organic matter contents and chemical characteristics (P and Ca; Table 1). Both contained about 50% sand. C, D and E were all silt loams. However, with more than 65% silt, the texture of E differed markedly from that of C and D (about 50% silt).

Table 1. Main characteristics of the studied soils.

Soil	A Loam	B Loam	C Silt loam	D Silt loam	E Silt loam
% Clay	10.0	10.4	19.4	13.3	15.9
% Silt	39.5	35.6	47.9	49.4	66.5
% Sand	47.8	50.0	30.7	34.5	15.6
% Organic matter	2.5	4.0	1.9	2.8	2.0
CEC* (mEq 100 g <sup>-1</sup> )	6.2	13.2	8.3	10.0	9.8
pH <sub>KCl</sub> (pH <sub>H2O</sub> )	5.0 (5.8)	5.3 (6.2)	5.9 (6.6)	4.7 (5.8)	5.2 (6.1)
Olsen P (mg kg <sup>-1</sup> )	53.6	21.3	37.9	40.5	20.5
K (mg kg <sup>-1</sup> )	166.0	141.1	572.0	273.9	107.9
Mg (mg kg <sup>-1</sup> )	60.3	72.4	108.5	102.5	78.3
Ca (mg kg <sup>-1</sup> )	786.5	1708	1101	1058.2	1780.3

\*(CEC) Cation Exchange Capacity Metson.

Nodules were abundant in all pots. For all measured traits, few significant differences were found between varieties either for birdsfoot trefoil or alsike clover for a given soil. However, a very significant soil effect was observed for all varieties. In table 2, since the results between varieties within a species were similar, data have been pooled for each species.

Birdsfoot trefoil produced more organs and thus more dry matter (1.25 g plant<sup>-1</sup>) in the silt loam D than in the other soils (Table 2). In D, significant differences between varieties were observed: cv. Lotanova and Albena produced fewer leaves per plant (around 93 leaves plant<sup>-1</sup>) than San Gabriele and Leo (around 115 leaves plant<sup>-1</sup>;  $p < 0.05$ ). For this species, results obtained with loam A were not so different from those of loam B. *L. corniculatus* is known to perform better than other pasture legumes at low P levels (Davis, 1991). The lowest yields were observed in E, in which the percentage of sand did not reach 20. Such results may suggest that a too low proportion of sand (< 30%) in silt soils may not be suitable for birdsfoot trefoil. The percentage of organic matter may also be an important criterion to consider for this species ( $\geq 2.5\%$  in A, B and D ;  $< 2.5\%$  in C and E; Table 1). It is often mentioned that *L. corniculatus* is able to grow in a very wide range of soils (Jones and Turkington, 1986). However, Macel *et al.* (2007) have shown that plant growth seems more influenced by soil characteristics than by the climate.

Table 2. Size, number of organs and dry weight of above ground parts in *Lotus corniculatus* and *Trifolium hybridum* grown in different soils for nine weeks (Values are means)

Soil	A	B	C	D	E	<i>p</i>
<i>Lotus corniculatus</i>						
Number of axes per plant	7.79 <sup>bc</sup>	8.47 <sup>b</sup>	6.80 <sup>c</sup>	10.92 <sup>a</sup>	5.63 <sup>d</sup>	***
Number of leaves per plant	77.80 <sup>b</sup>	83.11 <sup>b</sup>	63.90 <sup>c</sup>	104.96 <sup>a</sup>	55.56 <sup>c</sup>	***
Size of the longest axis (cm)	44.70 <sup>b</sup>	51.39 <sup>a</sup>	39.23 <sup>c</sup>	52.09 <sup>a</sup>	42.68 <sup>bc</sup>	***
Dry weight per plant (g)	0.86 <sup>bc</sup>	0.89 <sup>b</sup>	0.74 <sup>c</sup>	1.25 <sup>a</sup>	0.54 <sup>d</sup>	***
<i>Trifolium hybridum</i>						
Number of leaves per plant	20.96 <sup>b</sup>	18.40 <sup>c</sup>	25.91 <sup>a</sup>	27.47 <sup>a</sup>	15.11 <sup>d</sup>	***
Leaf area per plant (cm <sup>2</sup> )	136.84 <sup>c</sup>	123.24 <sup>c</sup>	158.36 <sup>b</sup>	186.34 <sup>a</sup>	86.17 <sup>d</sup>	***
Maximum height (cm)	22.38 <sup>b</sup>	31.67 <sup>ab</sup>	22.60 <sup>b</sup>	27.67 <sup>a</sup>	20.60 <sup>c</sup>	***
Dry weight per plant (g)	0.72 <sup>c</sup>	0.59 <sup>d</sup>	0.84 <sup>b</sup>	1.08 <sup>a</sup>	0.46 <sup>e</sup>	***

Different letters indicate significant difference between means -  $n = 16$  for *L. corniculatus* and *T. hybridum* (pooled results of 4 varieties for each species). \*\*\* :  $p < 0.0001$

As for birdsfoot trefoil, all varieties of alsike clover grown in D produced the tallest plants with the largest numbers of organs, leaf areas and dry weights (Table 2). In all soils, maximum height of cv. Dawn was significantly greater ( $25.3 \text{ cm} \pm \text{SE } 1.1$ ) than that of cv. Buffalo ( $21.7 \text{ cm} \pm \text{SE } 0.5$ ;  $p < 0.05$ ). Furthermore, in D, cv. Dawn produced a larger number of leaves ( $33 \text{ leaf plant}^{-1}$ ) than the other varieties (23 to 26 leaves;  $p < 0.05$ ). In our experiment, the silt loams with 30% sand seemed most suitable for alsike clover. Dry weights obtained with B and E were about 50% lower than those of D. Among the five soils, B and E presented the lowest P and K contents, but the highest Ca contents. The P requirements of alsike clover are known to be lower than those of red clover and white clover, but higher than those of birdsfoot trefoil (Davis, 1991).

## Conclusions

The effect of the physical characteristics of soil on the development of *L. corniculatus* would require further investigation. *T. hybridum* seems more affected by the chemical characteristics of the soil than *L. corniculatus*. A better understanding of relationships between silt soils and these types of legume species would enable us to propose grass-legume mixtures better adapted to a diversity of silt soils.

## Aknowledgements

This study was a part of a 3-year project conducted with the *Groupe Prairie des Pays de la Loire*. It was supported by the Pays-de-Loire Region.

## References

- Barlan M., Breazu I., Oprea G. And Neagu M. (2002) Genetic diversity among accessions of perennial grasses and *Lotus corniculatus* varieties. *Grassland Science in Europe*, 7, 400-401.
- Davis M.R. (1991) The comparative phosphorus requirements of some temperate perennial legumes. *Plant and Soil*, 133, 17-30.
- Goh K.M. and Bruce G.E. (2005) Comparison of biomass production and biological nitrogen fixation of multi-species pasture (mixed herb leys) with perennial ryegrass-white clover pasture with and without irrigation in Canterbury, New Zealand. *Agriculture, Ecosystem and Environment*, 110, 230-240.
- Hopkins A., Martyn T.M., Johnson R. H., Sheldrick R. D. and Lavender R. L. (1996) Forage production by two *Lotus* species as influenced by companion grass species. *Grass and Forage Science*, 51, 343-349.
- Jones D. A. and Turkington R. (1986). Biological flora of the British Isles. *Lotus corniculatus* L.. *Journal of Ecology*, 74, 1185-1212.
- Macel M., Lawson C.S., Mortimer S.R., Smilauerova M., Bischoff A., Crémieux G., Dolezal J., Edwards A., Lanta V., Bezemer M., Ven der Putten W., Igual J.M., Rodriguez-Barrueco C., Müller-Schärer H. and Steinger T. (2007) Climate vs. soil factors in local adaptation of two common plant species. *Ecology*, in press.

# Seedling growth and development characteristics of perennial clover species compared with perennial ryegrass

Black A.D. and O'Kiely P.

*Teagasc, Grange Beef Research Centre, Dunsany, County Meath, Ireland*

## Abstract

Seedling growth and development characteristics of 12 contrasting pasture cultivars were examined after an autumn sowing in County Meath, Ireland. Six cultivars of red clover (RC) and two cultivars each of Caucasian clover (CC), white clover (WC) and perennial ryegrass (PRG) were compared. The thermal time required for the appearance of the first leaf on the main stem was lower for PRG (143 °Cd) than the clovers (229 °Cd). The phyllochron was lower for PRG (93 °Cd) and WC (104 °Cd) than RC (127 °Cd) and CC (151 °Cd). The appearance of the first axillary leaf, which marked the start of branching, occurred after 335 °Cd for PRG, 551 °Cd for WC and 584-657 °Cd for RC. CC did not develop axillary leaves before the final harvest at 670 °Cd. Consequently, the number of leaves, leaf area and shoot dry weight of individual seedlings 54 days after sowing was greatest for PRG (19.9 leaves, 20.0 cm<sup>2</sup> and 146 mg) and lowest for CC (3.8 leaves, 5.0 cm<sup>2</sup> and 32 mg).

Keywords: pasture establishment, leaf development, leaf area, *Trifolium*, *Lolium perenne*

## Introduction

Improving animal performance through increasing the legume content of grazed swards is a recurring theme in grassland research (Peeters *et al.*, 2006). Traditionally, white clover (*Trifolium repens* L.) and perennial ryegrass (*Lolium perenne* L.) have been the species used. However, red clover (*T. pratense* L.) and Caucasian clover (*T. ambiguum* M. Bieb) may be included in a seed mixture to increase the total legume content of the sward. In particular, red clover cultivars developed to persist in grazed conditions exist (e.g. Grasslands Broadway; Rumball *et al.*, 2003) but there is little information about the establishment of these cultivars relative to other pasture species. For most pasture species, establishment success can be attributed to the ability of seedlings to intercept light for photosynthesis at an early stage after sowing (Moot *et al.*, 2000). Light interception is driven mainly by canopy or leaf area expansion which is the product of growth (leaf size) and development (leaf appearance rate and branching) components of the plant. Plant development rate is linearly related to temperature up to an optimum and each development stage can be quantified in thermal time (Tt) (Arnold and Monteith, 1974).

The objective was to examine the early growth (shoot weight and leaf area) and development (leaf appearance and branching) of seedlings of contrasting pasture species after an autumn sowing. There were six cultivars of red clover, either more suited to cutting or grazing, and two cultivars each of Caucasian clover, white clover and perennial ryegrass.

## Materials and methods

The experiment was conducted at Teagasc Grange Beef Research Centre, County Meath, Ireland (53°30'N, 6°40'W, 92 m above sea level), on a moderately drained brown earth soil which was cultivated to produce a fine textured, firm seedbed using conventional methods. Soil test results in January 2006 indicated no pH, P and K deficiencies for pasture growth (pH

6.3, Morgan's P 12.9 mg L<sup>-1</sup> and K 269 mg L<sup>-1</sup>). A randomised complete block design was laid out with four replicates and 12 cultivars in 4 m × 5 m plots. There were six cultivars of red clover, either more suited to cutting (Britta, Maro and Merviot) or grazing (Grasslands Broadway, Grasslands Colenso and Grasslands Sensation), and two cultivars each of Caucasian clover (Endura and KTA202), white clover (Aran and Avoca) and perennial ryegrass (Cashel and Spelga). Seeds were hand-sown and raked into the soil on 8 September 2006. Seeding rates were calculated to sow 500 viable seeds m<sup>-2</sup> based on germination tests and 1000 seed weights. Caucasian clover seed was lime-coated and inoculated with the *Rhizobium leguminosarum* biovar *trifolii* strain ICC148 immediately before sowing.

Once emerged from the soil, three median plants in each plot were marked with coloured wires for detailed monitoring. The number of emerged leaves on the marked plants was recorded every 2-4 days until 54 days after sowing. Leaves were considered to have emerged when the petiole was first visible for the clovers and when the leaf tip was first visible for perennial ryegrass. The appearance of axillary leaves, which emerge in the axils of main-stem leaves, was also recorded. At 54 days after sowing, the shoots of three representative plants in each plot were harvested to ground level. The number and area of leaves that emerged from main stem and axillary nodes were measured for each main-stem node position. Leaf area was measured by taking digital images of detached emerged leaves and analysing the images using the software 'QUANT' (Vale *et al.*, 2003). Samples were then dried in a forced-air oven at 98 °C (24 h) to determine shoot dry weight.

Daily maximum (*T*<sub>max</sub>) and minimum (*T*<sub>min</sub>) air temperatures (1.5 m above ground) and rainfall were recorded from a meteorological station situated *ca.* 500 m east of the site (Figure 1). Thermal time (°Cd) was calculated daily using Equation 1 and daily Tt was summed to give accumulated Tt between successive plant development stages. A base temperature (*T*<sub>*b*</sub>) of 0°C was used for all 12 cultivars (Moot *et al.*, 2000; Black *et al.*, 2006). The phyllochron (°Cd), or leaf appearance interval, was calculated from the reciprocal of the slope of linear regressions between the number of main-stem leaves and accumulated Tt.

$$\text{Thermal time (°Cd)} = \sum \left[ \left( \frac{T_{\max} + T_{\min}}{2} \right) - T_b \right] \quad (1)$$

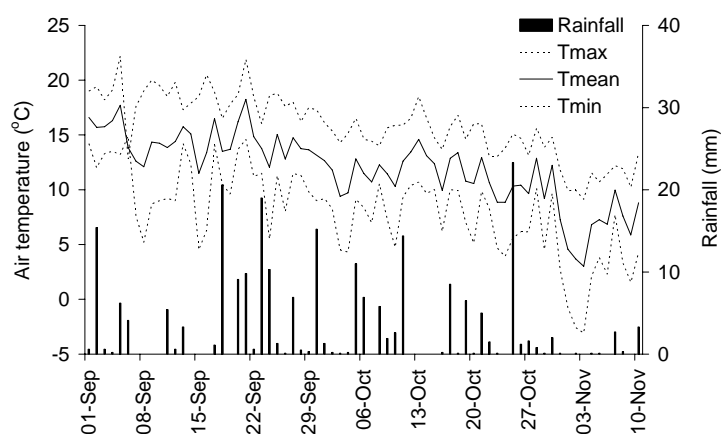

Figure 1. Daily maximum (*T*<sub>max</sub>), mean (*T*<sub>mean</sub>) and minimum (*T*<sub>min</sub>) air temperatures (1.5 m) and rainfall from September to November, 2006 at Grange Beef Research Centre.

Data were transformed (ln) when necessary to satisfy the requirements of normality and homogenous variances for parametric tests. Back-transformed data are presented. The null hypotheses that there were no differences between treatment means were tested by one-way ANOVA and significantly different (*P* = 0.05) treatment means were separated using Tukey's text. Associations between shoot dry weight and the area and number of leaves on each seedling were tested using Pearson's product moment correlation test.

## Results and discussion

The accumulated Tt required for the appearance of the first leaf on the main stem was lower ( $P < 0.001$ ) for the two perennial ryegrass cultivars at 143 °Cd than all of the clover cultivars at 229 °Cd (Table 1). The phyllochron was similar ( $P > 0.05$ ) for perennial ryegrass (93 °Cd) and white clover (104 °Cd), and greater ( $P < 0.05$ ) for the red clover (127 °Cd) and Caucasian clover (151 °Cd) cultivars. The appearance of the first axillary leaf, which marked the start of branching, occurred after 335 °Cd for perennial ryegrass and 551 °Cd for white clover ( $P < 0.05$ ). For red clover, it ranged between 584 °Cd for Grasslands Broadway and 657 °Cd for Merviot ( $P < 0.05$ ). In contrast, the Caucasian clover cultivars did not developed any axillary leaves before the final harvest at 670 °Cd after sowing, which was consistent with previous studies in temperate environments (Black *et al.*, 2006).

Table 1. Seedling growth and development of 12 cultivars of white clover (WC), Caucasian clover (CC), red clover (RC), or perennial ryegrass (PRG) up to 54 days after sowing.

Species	Cultivar	First leaf appearance (°Cd)	Phyllochron (°Cd)	Axillary leaf initiation (°Cd)	Shoot dry weight plant <sup>-1</sup> (mg)	Leaf area plant <sup>-1</sup> (cm <sup>2</sup> )	Number of leaves plant <sup>-1</sup>
WC	Avoca	236 <sup>cd</sup>	105 <sup>abc</sup>	551 <sup>b</sup>	25 <sup>e</sup>	4.2 <sup>d</sup>	8.9 <sup>b</sup>
	Aran	234 <sup>cd</sup>	104 <sup>abc</sup>	552 <sup>bc</sup>	34 <sup>cde</sup>	5.6 <sup>cd</sup>	7.3 <sup>bc</sup>
CC	Endura	248 <sup>d</sup>	154 <sup>f</sup>	>670 <sup>f</sup>	28 <sup>de</sup>	4.3 <sup>d</sup>	3.7 <sup>e</sup>
	KTA202	233 <sup>cd</sup>	148 <sup>f</sup>	>670 <sup>f</sup>	36 <sup>bcde</sup>	5.7 <sup>cd</sup>	3.8 <sup>e</sup>
RC	Broadway	229 <sup>cd</sup>	118 <sup>bcde</sup>	584 <sup>bcd</sup>	41 <sup>bcd</sup>	7.5 <sup>bc</sup>	7.0 <sup>bcd</sup>
	Britta	219 <sup>bc</sup>	130 <sup>cdef</sup>	623 <sup>de</sup>	43 <sup>bcd</sup>	7.3 <sup>bc</sup>	5.4 <sup>d</sup>
	Colenso	229 <sup>cd</sup>	109 <sup>abcd</sup>	605 <sup>cde</sup>	45 <sup>bc</sup>	8.8 <sup>bc</sup>	6.2 <sup>cd</sup>
	Merviot	229 <sup>cd</sup>	139 <sup>ef</sup>	657 <sup>e</sup>	48 <sup>bc</sup>	9.4 <sup>b</sup>	5.5 <sup>d</sup>
	Sensation	206 <sup>b</sup>	131 <sup>def</sup>	634 <sup>de</sup>	51 <sup>bc</sup>	9.8 <sup>b</sup>	5.3 <sup>d</sup>
	Maro	223 <sup>bc</sup>	134 <sup>def</sup>	632 <sup>de</sup>	57 <sup>b</sup>	9.6 <sup>b</sup>	5.7 <sup>cd</sup>
PRG	Spelga	143 <sup>a</sup>	89 <sup>a</sup>	326 <sup>a</sup>	130 <sup>a</sup>	18.8 <sup>a</sup>	19.6 <sup>a</sup>
	Cashel	143 <sup>a</sup>	97 <sup>ab</sup>	344 <sup>a</sup>	161 <sup>a</sup>	21.2 <sup>a</sup>	20.1 <sup>a</sup>
s.e.d.		7.3	8.0	16.7	1.1	1.15	1.08
<i>P</i> value		0.001	0.001	0.001	0.001	0.001	0.001

Means within columns with different superscripts are significantly different ( $P = 0.05$ ).

There was a highly significant difference ( $P < 0.001$ ) between the mean shoot weights which was largely accounted for by a greater ( $P < 0.05$ ) mean shoot weight of perennial ryegrass (146 mg) compared with the clover cultivars (Table 1). For the clovers, mean shoot weights were greatest for red clover, ranging between 57 mg for Maro and 41 mg for Grasslands Broadway, and lowest for Endura (28 mg) and Avoca (25 mg). Across all 12 cultivars, there was a strong positive correlation ( $r = 0.955$ ,  $P < 0.001$ ) between shoot weight and leaf area per plant, and a weaker positive correlation ( $r = 0.748$ ,  $P < 0.001$ ) between shoot weight and the number of leaves per plant. This weaker correlation was associated with white clover plants having twice the mean number of leaves ( $P < 0.05$ ) but similar ( $P > 0.05$ ) shoot weights (8.1 leaves and 30 mg) than Caucasian clover plants (3.8 leaves and 32 mg).

The differences between the mean leaf areas of the cultivars were associated with the mean area and number of leaves per main-stem node position, as illustrated for five contrasting cultivars in Figure 2. The mean number of main-stem leaves was greatest for Cashel with seven, and lowest for Endura with only four ( $P < 0.001$ ) main-stem leaves. For all cultivars except Endura, the development of axillary leaves was indicated by an increase above one in the number of leaves per main-stem node. The point of maximum axillary leaf development occurred at the first or second main-stem node position. Axillary leaf development was greatest for Cashel with 7.5 leaves on the first main-stem node compared with ( $P < 0.05$ ) 2.8 leaves for Avoca and *ca.* 2.0 leaves for Maro and Grasslands Broadway.



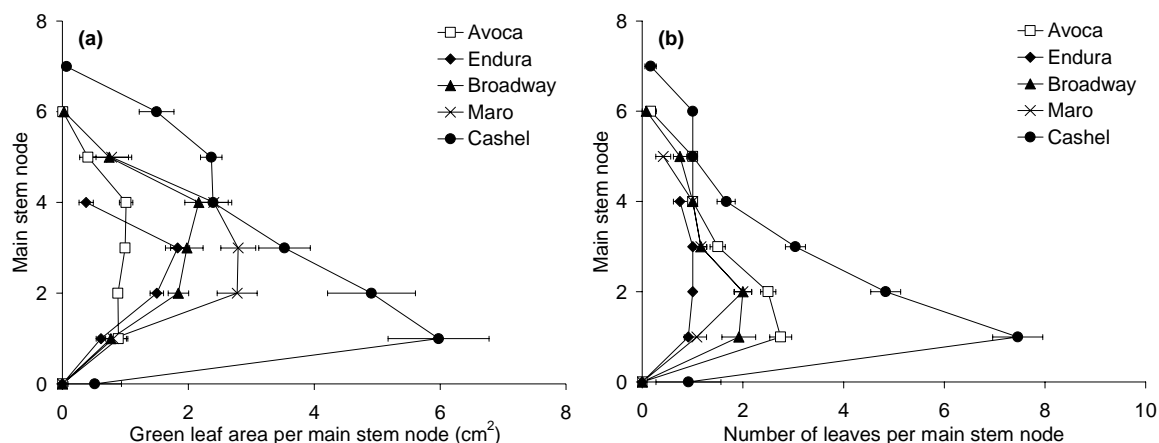

Figure 2. (a) Green leaf area and (b) number of leaves at each main-stem node position ( $\pm$  s.e.m.) for white clover cv. Avoca, Caucasian clover cv. Endura, red clover cv. Grasslands Broadway and cv. Maro, and perennial ryegrass cv. Cashel, 54 days after sowing.

These results demonstrate differences in seedling growth and development between pasture cultivars and suggest they need to be considered when making decisions on time of sowing and composition of pasture seed mixtures. For example, the red clover cultivars all had high rates of leaf area expansion and could therefore be sown in autumn with perennial ryegrass. In contrast, spring sowing of Caucasian clover in seed mixtures that do not include perennial ryegrass or red clover should be recommended, to minimise the interval in days to axillary leaf development and to reduce competition for light from other pastures species.

## Conclusion

There were significant differences between the growth and development of the 12 cultivars up to 54 days after sowing. The perennial ryegrass cultivars required less Tt for development and had greater leaf areas and shoot weights than the clovers, whereas Caucasian clover required the most Tt for development and had the lowest leaf areas and shoot weights.

## References

- Arnold S.M. and Monteith J.L. (1974) Plant development and mean temperature in a Teesdale habitat. *Journal of Ecology*, 62, 711-720.
- Black A.D., Moot D.J. and Lucas R.J. (2006) Development and growth characteristics of Caucasian clover and white clover seedlings, compared with perennial ryegrass. *Grass and Forage Science*, 61, 442-453.
- Moot D.J., Scott W.R., Roy A.M. and Nicholls A.C. (2000) Base temperature and thermal time requirements for germination and emergence of temperate pasture species. *New Zealand Journal of Agr. Research*, 43, 15-25.
- Peeters A., Parente G. and Le Gall A. (2006) Temperate legumes: key-species for sustainable temperate mixtures. In: Lloveras J., González-Rodríguez A., Vázquez-Yañez O., Piñeiro J., Santamaría O., Olea L. and Poblaciones M.J. (eds) Sustainable Grassland Productivity. *Proceedings of the 21<sup>st</sup> General Meeting of the European Grassland Federation, Badajoz, Spain, 2006*, 205-220.
- Rumball W., Keogh R.G. and Miller J.E. (2003) 'Crossway' and 'Grasslands Broadway' red clovers (*Trifolium pratense* L.). *New Zealand Journal of Agricultural Research*, 46, 57-59.
- Vale F.X.R., Fernandes E.I.F. and Liberto J.R. (2003) QUANT: A software for plant disease severity assessment. In: Solving Problems in the Real World. *Proceedings of the 8<sup>th</sup> International Congress of Plant Pathology, Christchurch, New Zealand, 2003*, 105.

# The role of seed rate of white clover and method of sod preparation in pasture overdrilling

Goliński P., Kozłowski S. and Golińska B.

*Department of Grassland Sciences, August Cieszkowski Agricultural University of Poznań, Wojska Polskiego 38/42, 60-627 Poznań, Poland*

## Abstract

An experiment was carried out during 2001-2002 to study the effect of different seed rates of white clover (3, 4, 5 and 6 kg ha<sup>-1</sup>) and the method of sod preparation (no treatment, sward 5 to 6 cm high; low cutting, 3 cm high; rototiller) on the success of overdrilling in spring using a Vredo drill on a pasture situated on Histosols soils. The following parameters were determined: number of seedlings per 1 m<sup>2</sup>, proportion of clover in sward, DM yield and herbage quality using commonly applied methods. It was found that increasing the seed rate of white clover, the average proportion of this species increased in the sward during the first year of utilization. The sod preparation of the old pasture, using a rototiller, guaranteed the best emergence as well as growth and development of seedlings. Increasing the seed rate of white clover did not significantly affect DM yields. However, this factor was found to have a significant effect on the quality of herbage, particularly in the treatment of sod preparation before overdrilling by rototiller.

Keywords: white clover, forage quality, overdrilling, pasture renovation, seed rate

## Introduction

Central Poland is characterised by periodic shortages of precipitation, which causes white clover (*Trifolium repens*) to disappear rapidly from the swards sown with grass-clover mixtures. In sustainable forage production systems, it is also becoming necessary to restore a higher proportion of this species in the sward. The best method of the re-introduction of white clover into pastures is overdrilling (Hrazdira, 1989). Many factors affect the success of this undertaking (Sheldrick, 2000). One, easily adjustable factor is that of seed rate. However, despite the use of direct drills on Histosols soils, the effectiveness of overdrilling with white clover on pastures dominated by *Poa pratensis* and *Poa trivialis* is unsatisfactory. In this situation, it is possible that, as suggested by Gos and Czyż (1995), appropriate sod preparation before overdrilling may be of crucial importance.

The aim of the performed investigations was to assess the impact of different seed rates of white clover and methods of sod preparation on the effects of pasture overdrilling.

## Materials and methods

A study was carried out during 2001-2002, at Brody Experimental Station (52° 26' N, 16° 18' E) of the August Cieszkowski Agricultural University, Poznań, to evaluate the effect of different seed rates (factor I: 3 vs. 4 vs. 5 vs. 6 kg ha<sup>-1</sup>) of white clover cv. Barbian in the conditions of different methods of sod preparation (factor II: no treatment, sward 5 to 6 cm high; low cutting, 3 cm high; rototiller followed by rolling) on the success of overdrilling. The pasture used in the experiment was situated on poorly mineralised Histosols soils (pH<sub>KCl</sub> – 6.5, N<sub>t</sub> – 0.62%, P<sub>2</sub>O<sub>5</sub> – 67.9 mg 100 g<sup>-1</sup>, K<sub>2</sub>O – 30.0 mg 100 g<sup>-1</sup>, Mg – 7.1 mg 100 g<sup>-1</sup>). Plot size was 8 m × 2.5 m and each treatment was replicated four times in a plot block-design. The

botanical composition of the experimental sward at the time of overdrilling was: *Poa trivialis* – 26.5%, *Poa pratensis* – 20.5%, *Agropyron repens* – 17.5%, *Festuca pratensis* – 3.8%, *Lolium perenne* – 5.2%, *Trifolium repens* – 2.3%, other grasses and herbs – 24.2%. The seeds were sown in spring (early April 2001) using a Vredo drill. Weather conditions were favourable for the growth and development of seedlings following overdrilling. The monthly mean temperature and amount of precipitation (mm) for April, May and June 2001 was 8.1, 14.8, 15.3 °C and 37.3, 34.7, 75.6 mm respectively. The yearly average temperature and total of precipitation for 2001 and 2002 was 9.0, 9.7 °C and 648.2, 750.5 mm respectively. Fertiliser was applied each year at a rate of: N – 80 kg ha<sup>-1</sup>, P<sub>2</sub>O<sub>5</sub> - 80 kg ha<sup>-1</sup>, K<sub>2</sub>O - 140 kg ha<sup>-1</sup> and 3-4 regrowths were harvested. The effectiveness of overdrilling was evaluated on the basis of the number of seedlings per 1 m<sup>2</sup> after 25 and 50 days from sowing as well as the proportion of introduced clover in the sward (samples were separated and the fractions were weighed). Dry matter (DM) yield was measured on an area of 15 m<sup>2</sup>. The herbage was dried in a forced-draught oven at 60 °C. Crude protein (CP) and acid detergent fibre (ADF) were also measured on selected plots using commonly accepted methods (Kjeldahl and Soest and Marcus (1964), respectively). Tests of the main effects were performed by F-tests. Averages were separated by the LSD and were declared different at the p<0.05 level.

## Results and discussion

Increasing the seed rate of white clover resulted in a greater number of seedlings per unit area, 25 days after overdrilling with greater seed rates leading to greater seedling numbers (Table 1). Although seedling number dropped by an average of 30% by the time the second seedling measurement was taken (fifty days after overdrilling), differences in the number of seedlings per unit area continued to be very clear. In comparison with the treatment where 3 kg ha<sup>-1</sup> of seed was sown, the doubling of this seed rate, irrespective of the methods of sod preparation, resulted in 131% increase of white clover seedlings. After overdrilling, the best seedling emergence results of white clover were observed in the rototiller treatment which destroyed the sod surface and exposed soil and, in so doing, created better conditions for the growth and development of seedlings.

Table 1. Effect of seed rate of white clover and method of sod preparation in pasture overdrilling on the number of seedlings per 1 m<sup>2</sup>.

Seed rate (kg ha <sup>-1</sup> )	After 25 days from sowing				After 50 days from sowing			
	Method of sod preparation*			average	Method of sod preparation*			average
	NT	LC	RT		NT	LC	RT	
3	102	171	225	166	73	121	153	116
4	124	252	323	233	92	142	276	170
5	141	310	458	303	108	198	424	243
6	188	472	627	429	134	219	450	268
LSD <sub>0.05</sub>	11.8	21.7	40.8	51.8	13.9	17.6	23.3	44.1

\* NT – no treatment, LC – low cutting, RT – rototiller

In each treatment of sod preparation, particularly when the rototiller was used, increasing the seed rate from 3 to 6 kg ha<sup>-1</sup>, also increased the proportion of this species in the sward with the effects of 32.4% and 24.4% in the sowing year and the first year of utilisation, respectively (Table 2). A similar relationship was found in our earlier investigations on the increased seed rates used to improve pastures with perennial ryegrass and meadow fescue (Goliński and Kozłowski, 2004). The better growth and development of seedlings in the rototiller treatment resulted in a higher proportion of white clover in the sward when

compared with low cutting and no preparation before overdrilling which averaged 26.8% in the year of sowing and 21.8% in the first year of utilisation. White clover replaced in the sward mainly *Poa trivialis* and other annual weeds. A lower proportion of white clover in the sward 13.8% and 10.8%, respectively, was recorded in the low cutting treatment. No preparation of the sod before overdrilling limited the incidence of this species in the sward to the level of 9.9% in the sowing year and only 6.6% in the first year of utilisation. In both investigation years, in the case of this treatment, the impact of the applied seed rate on this parameter was negligible and non significant.

Table 2. Effect of seed rate of white clover and method of sod preparation in pasture overdrilling on the proportion of white clover in the sward (%).

Seed rate (kg ha <sup>-1</sup> )	Sowing year				First year of utilization			
	Method of sod preparation*			average	Method of sod preparation*			average
	NT	LC	RT		NT	LC	RT	
3	9.5	12.4	23.8	15.2	5.9	9.4	19.3	11.5
4	10.2	13.5	24.4	16.0	7.2	10.5	20.5	12.7
5	9.8	14.1	27.4	17.1	6.3	11.2	23.5	13.7
6	9.9	15.2	31.5	18.9	7.0	12.0	24.0	14.3
LSD <sub>0.05</sub>	ns	1.13	1.26	1.35	ns	ns	0.74	0.83

\* NT – no treatment, LC – low cutting, RT – rototiller

Increasing the seed rate of white clover did not have a significant effect on sward yields (Table 3). In comparison with the treatment where 3 kg ha<sup>-1</sup> of seed was sown, the seed rate of 6 kg ha<sup>-1</sup>, irrespectively of the methods of sod preparation, resulted in 3.4% increase of DM yield in the first year of utilization. A similar result was found in our earlier investigations (Goliński and Kozłowski, 2004). Also, the method of sod preparation did not have a significant effect on the yielding of sward.

Table 3. Effect of seed rate of white clover and method of sod preparation in pasture overdrilling on DM yield (t ha<sup>-1</sup> y<sup>-1</sup>).

Seed rate (kg ha <sup>-1</sup> )	Sowing year				First year of utilization			
	Method of sod preparation*			average	Method of sod preparation*			average
	NT	LC	RT		NT	LC	RT	
3	4.82	4.91	4.70	4.81	8.05	7.69	7.86	7.87
4	4.95	4.75	4.57	4.76	8.12	8.12	8.07	8.10
5	4.78	4.86	4.75	4.80	8.08	8.45	7.98	8.17
6	4.87	4.81	4.57	4.75	8.17	8.22	8.03	8.14
LSD <sub>0.05</sub>	ns	ns	ns	ns	ns	ns	ns	ns

\* NT – no treatment, LC – low cutting, RT – rototiller

The improvement of the sward botanical composition obtained following the introduction of white clover exerted a significant impact on herbage quality, above all, on the CP content, as corroborated by Taube *et al.* (1991) and others. Over the two-year period of investigations, it was found that increasing the seed rate from 3 to 6 kg ha<sup>-1</sup> resulted in a significant increase in protein concentrations (from 159.2 to 173.8 g kg<sup>-1</sup> DM) and a decline in ADF content (Table 4). It is worth emphasizing that much better herbage quality was obtained when the rototiller for sod preparation was used than low cutting and no preparation before overdrilling. Herbage from the rototiller treatment was characterised by the highest CP content – average for all seed rates – 188.8 g kg<sup>-1</sup> DM which was 24.0% higher than the control. Herbage from this

treatment was further characterised by the lowest content of ADF – 241.4 g kg<sup>-1</sup> DM, which was by 8.0% less than the control.

Table 4. Effect of seed rate of white clover and method of sod preparation in pasture overdrilling on quality of herbage (average from two years of pasture utilisation).

Seed rate (kg ha <sup>-1</sup> )	CP (g kg <sup>-1</sup> DM)				ADF (g kg <sup>-1</sup> DM)			
	Method of sod preparation*			average	Method of sod preparation*			average
	NT	LC	RT		NT	LC	RT	
	142.5	152.0		159.2	271.5	260.8		262.7
3			183.0				255.8	
4	151.0	161.1	191.5	167.9	260.2	252.5	250.3	254.3
5	156.7	166.2	188.5	170.5	258.5	245.1	237.1	246.9
6	158.5	171.0	192.0	173.8	259.7	248.3	222.5	243.5
LSD <sub>0.05</sub>	4.09	4.60	2.82	2.76	ns	3.33	5.22	5.61

\* NT – no treatment, LC – low cutting, RT – rototiller

The effects of pasture overdrilling with white clover using higher seed rates (5-6 kg ha<sup>-1</sup>) and rototiller for sod preparation before slot seeding show that the introduction of this species into the sward of pasture situated on Histosols soils is possible.

## Conclusions

Increasing the seed rate of white clover used in pasture overdrilling from 3 to 6 kg ha<sup>-1</sup> increased number of seedlings per unit area. It was also found that increasing the seed rate of this species, the average proportion of white clover increased in the sward during the first year of utilization. The sod preparation of the old pasture situated on Histosols soils, using a rototiller, guaranteed the best emergence as well as growth and development of seedlings. Increasing the seed rate of white clover did not significantly affect DM yields. However, this factor was found to have a significant effect on the quality of herbage, primarily with regard to concentrations of CP and ADF, particularly in the treatment of sod preparation before overdrilling by rototiller.

## References

- Gos A and Czyż H (1995) Estimation of sward control methods of meadows situated on peat-muck soil and destined for sod seeding. *Annales UMCS, Sectio E*, 50, 153-156. (in Polish)
- Hrazdira Z (1989) Grassland improvement by clover direct drilling. *Proceedings of the XVI International Grassland Congress*, Nice, France, 563-564.
- Goliński P. and Kozłowski S. (2004) The role of seed rate of *Festuca pratensis* and *Lolium perenne* in pasture overdrilling. *Grassland Science in Europe*, 9, 553-555.
- Sheldrick R.D. (2000) Sward establishment and renovation. In: Hopkins A. (ed.) *Grass. Its production and utilization*. Blackwell Science, Oxford, UK, 13-30.
- Soest P.J. van and Marcus W.C. (1964) Method for the determination of cellwall constituents in forages using detergent and the relationship between this fractions and voluntary intake and digestibility. *Journal of Dairy Science*, 47, 704-714.
- Taube F, Kornher A, Südekum K H, Wörner M and Pabst K (1991) Slot seeding of white clover into a permanent pasture: impact on botanical composition, dry matter yield and quality of herbage. *Report of the EGF-Symposium*, Graz, Austria, 18-21.

## Effect of the fertilization on the feed value of permanent grassland

Rodrigues A.<sup>1,3</sup>, Andueza D.<sup>1</sup>, Violleau S.<sup>2</sup>, Fefeu B.<sup>2</sup>, Picard F.<sup>1</sup>, Cecato U.<sup>3</sup> and Baumont R.<sup>1</sup>

<sup>1</sup>INRA-URH Centre de Clermont-Ferrand 63122 Saint Genès Champanelle France

<sup>2</sup>Chambre Départementale d'Agriculture (63) 11 r Pierre de Fermat 63170 Aubière France

<sup>3</sup>Universidade Estadual de Maringa Av. Colombo, 5790 CEP 87020-900 Maringa-Pr. Brazil

### Abstract

A field trial was carried out in the Central Massif of France in order to evaluate the effect of the fertilization and the type of fertilization (organic vs. mineral) on the botanical composition (proportion of grasses, legumes, forbs and senescent material), morphological composition (percentage of leaves within grasses and forbs), chemical composition (crude ash (CA), crude protein (CP), neutral detergent fibre (NDF), acid detergent fibre (ADF) and acid detergent lignin (ADL)) and feed value (organic matter digestibility and ingestibility) of a permanent grassland. Samples were collected at two harvest dates along the first cycle of growth during 2005 and 2006 (heading and flowering of *Dactylis glomerata* respectively). The treatments included mineral fertilization (120 kg ha<sup>-1</sup> of N 60 kg ha<sup>-1</sup> of P and 150 kg ha<sup>-1</sup> of K), organic fertilization (10 t ha<sup>-1</sup> of cattle compost) and control (without fertilization). Chemical composition analyses and feed value were estimated by NIRS. No differences between fertilization treatments were found for the proportion of grasses, forbs, senescent material, leaves percentage, CA, NDF, ADF, ADL, organic matter digestibility and ingestibility. Legumes proportion under mineral fertilization decreased significantly by 86% and 51% as compared to the control and organic fertilization respectively.

Keywords: permanent grassland, floristic composition, morphological composition, digestibility, ingestibility

### Introduction

Fertilization is one of the more important factors that influences forage production in temperate areas. Fertilizers application is a common practice used to increase the productivity of grasslands. Its effects are well known. Nowadays, the agricultural policies suggest the diminution of chemical fertilization and promote the use of other sources. The use of the organic fertilizers can be an alternative to the use of soluble fertilizers. However, their effects on the nutritive value of forages are not so well known.

This communication aims to assess the effect of the fertilization and the type of fertilization (organic vs. mineral) used in practical conditions, on the botanical composition morphological composition and feeding value of permanent grassland.

### Material and methods

The trial was carried out in permanent grassland located at Picherande, in the Central Massif of France (1000 m asl) in a volcanic soil. The annual mean temperature is 7.6 °C and the annual precipitation is 1404 mm year<sup>-1</sup>.

In 2004, three fertilizing treatments were applied on plots of 42 m<sup>2</sup> according to a randomized block design with four replicates. The following treatments were applied: mineral fertilization (MF), organic fertilization (OF) and no fertilization (NF). MF consisted of the application of an annual dose of 120, 60 and 150 kg ha<sup>-1</sup> of nitrogen, phosphorus and potassium

respectively. The nitrogen dose was fractionated in two times; 67% at the end of March and 33% in the middle of June. OF treatment consisted of topdressing 10 t of cattle compost ha<sup>-1</sup>. It was equivalent to 46, 22 and 96 kg ha<sup>-1</sup> of nitrogen, phosphorus and potassium, respectively. Treatments have been applied each year from the implantation of the trial.

The meadow is usually cut once at the end of spring, then another harvest is made at the end of July and finally it is grazed by milk cows at the end of September.

In 2005 and 2006 plots were sampled at two dates along the first growth cycle (heading and flowering of *Dactylis glomerata* respectively). Two 0.5 x 0.5 m<sup>2</sup> samples were taken randomly in each plot. They were clipped at 5 cm stubble height. After weighting the forage obtained and transported to the laboratory, two subsamples were taken. A subsample was dried at 60°C during 72h, and then was ground in a hammer mill through a 0.8 mm sieve. The second subsample was stored at -20 °C and was used to characterize the botanical composition. This was determined by hand separation and weighing the samples of the different species. Senescent material (Sm) was considered globally for all plants. Samples of different grasses, legumes and forbs were then regrouped.

Ground samples were analyzed for crude ash (CA), crude protein (CP) according to AOAC (1990) and for neutral detergent fibre (NDF), acid detergent fibre (ADF), acid detergent lignin (ADL) according to Van Soest *et al.* (1991). Analyses were made using the near infrared spectroscopy (NIRS) technique. NIR spectra were obtained with a monochromator (FOSS-NIRSystems 6500, Silver Spring, MD, USA) which scans the spectral range of 400 – 2500 nm. *In vivo* organic matter digestibility (OMD) and ingestibility (ING) data were also estimated by NIRS. The statistical parameters of the calibration models are shown in Table 1.

Table 1: NIR statistics for crude ash (CA) (g kg<sup>-1</sup>), crude protein (CP) (g kg<sup>-1</sup>), neutral detergent fibre (NDF) (g kg<sup>-1</sup>), acid detergent fibre (ADF) (g kg<sup>-1</sup>), acid detergent lignin (ADL) (g kg<sup>-1</sup>), *in vivo* organic matter digestibility (OMD) and ingestibility (ING) (g kg PV<sup>0.75</sup>).

	N	Mean	Std	Range	SEP	R <sup>2</sup>
CA	54	8.7	2.07	2.06 - 14.98	0.79	0.85
CP	55	11.09	2.48	3.64 - 18.52	0.71	0.92
NDF	54	58.9	6.58	6.57 - 78.53	0.79	0.95
ADF	54	33.6	5.43	5.42 - 49.89	1.57	0.87
ADL	54	5.90	2.56	2.56 - 13.59	1.89	0.87
OMD	60	68.9	6.80	48.20 - 89.01	1.91	0.92
ING	90	65.9	13.3	21.10 - 110.10	5.28	0.76

N: Number of samples; Std: standard deviation; SEP; Standard error of prediction; R<sup>2</sup>: Coefficient of determination.

Data of grasses, legumes, forbs, and NIRS estimates of chemical composition and feed value were submitted to an analysis of variance according to a repeated measurement design. Analyses of botanical data were performed on transformed data by arcsine of the square root. The Mixed procedure of SAS statistical package (SAS, 1998) was used to perform the statistical analyses.

## Results and discussion

The mean herbage yield was 7.0, 7.7 and 8.5 t ha<sup>-1</sup> for NF, OF and MF respectively. The increase of dry matter yield caused by the mineral fertilization was much higher in the flowering cut than in the heading cut (data not shown). Results of grasses, legumes, forbs proportions, and senescent material are shown in Table 2. The fertilization effect was not significant for the grasses and forbs proportions. However, the percentage of legumes, decreased significantly when comparing MF to NF treatment. The decline of legumes by effect of the fertilization has been reported by several authors (Carlen *et al.*, 1998). In relation

to morphological composition, no differences between fertilizing treatments were found for the proportion of forbs leaves, but the percentage of grasses lamina (GF) decreased by the effect of fertilization ( $P=0.07$ ) (Table 2). Calvière and Duru (1999), reported a decrease of leaf/stem ratio of grasses and dicotyledons when a meadow was fertilized with several doses of nitrogen and phosphorus. They suggest an adjustment of grasses towards the reproductive mode according to the nutrient availability.

Table 2: Grasses, forbs and legumes proportions, senescent material (SM), grasses leaves (GF) and forbs leaves (FF) of a permanent grassland at heading (HC) and flowering (FC) in 2005 and 2006.

	HC			FC			SEM	Y	F	D	Y*D
	NF	OF	MF	NF	OF	MF					
Grasses	53.5	59.6	56.0	65.4	71.3	67.0	0.70	0.895	0.757	0.094	0.215
Forbs	41.8	37.6	41.0	26.8	17.4	23.3	0.63	0.965	0.640	0.007	0.176
Legumes	2.4	0.8	0.5	2.1	2.1	0.2	0.08	0.089	0.001	0.836	0.555
SM	1.1	1.6	1.6	4.0	7.0	7.1	0.07	0.024	0.135	0.001	0.103
GF	46.1	36.8	38.2	37.1	29.8	34.9	0.13	0.001	0.070	0.030	0.630
FF	43.9	57.4	53.1	47.4	74.9	71.1	0.98	0.870	0.110	0.110	0.970

NF = non-fertilized control; OF = Organic fertilized; MF = Mineral fertilized

Y = Year; F = Fertilization; D = Date of harvest; SEM = Standard error of means.

MF plots had higher CP concentrations than OF and NF (Table 3). The higher nitrogen dose of MF compared to NF and OF can explain this result (Demarquilly, 1970).

No differences between fertilization treatments ( $p>0.05$ ) were found for the cell wall content, and *in vivo* OMD (Table 3). These results agree with those obtained by Peyraud *et al.* (1997), working with ryegrass and with those of Demarquilly (1970), working with permanent grasslands.

Table 3: Crude ash (CA) ( $\text{g kg}^{-1}$ ), crude protein (CP) ( $\text{g kg}^{-1}$ ), neutral detergent fibre (NDF) ( $\text{g kg}^{-1}$ ), acid detergent fibre (ADF) ( $\text{g kg}^{-1}$ ), acid detergent lignin (ADL) ( $\text{g kg}^{-1}$ ), *in vivo* organic matter digestibility (OMD) and ingestibility (ING) ( $\text{g kg PV}^{0.75}$ ) of a permanent grassland at heading (HC) and flowering (FC) of cookfost (*Dactylis glomerata*) in 2005 and 2006.

	HC			FC			SEM	Y	F	D	Y*D
	NF	OF	MF	NF	OF	MF					
CA	76.2	86.9	88.4	71.1	71.4	75.3	0.40	0.374	0.090	0.002	0.664
CP	119.5	121.1	142.0	90.5	85.7	103.3	0.38	0.001	0.001	0.001	0.002
NDF	475.0	494.2	477.0	594.0	601.0	600.0	1.88	0.061	0.763	0.001	0.002
ADF	265.2	270.0	266.0	332.3	340.6	343.1	0.76	0.001	0.618	0.001	0.001
ADL	36.2	34.7	32.6	51.0	51.3	54.1	0.18	0.001	0.969	0.001	0.001
OMD	0.77	0.78	0.79	0.64	0.64	0.65	1.24	0.001	0.606	0.001	0.001
ING	66.0	67.9	74.1	65.6	62.8	64.9	2.03	0.598	0.094	0.006	0.728

NF = Non-fertilized control; OF = Organic fertilized; MF = Mineral fertilized

Y = Year; F = Fertilization; D = Date of harvest; SEM = Standard error of means.

Plots fertilized with mineral fertilization showed higher values of ING than that of NF and OF ( $P=0.09$ ). This result is difficult to explain. Demarquilly (1970), reported variable results depending on the type of forage (ryegrass or permanent grassland), but concerning the permanent grasslands the ingestibility of forages obtained from the second and third regrowths of the low fertilized meadows was higher than that topdressed with a high nitrogen dose. In agreement to this author, differences between grasses and forbs composition of different fertilization treatments could partially explain our results.



## Conclusions

From these results it can be concluded that the change of fertilization strategy has only a moderately effect on the feed value of the permanent grassland. A longer period of time may be needed to confirm these results. The floristic composition could be altered by effect of fertilization and therefore the nutritive value of different plots.

## Acknowledgements

We wish to thank the GAEC Edelweiss for his kind permission to conduct the trial on his farm.

## References

- AOAC (1990) Official Methods of Analyses, 15th ed., Association of Official Analytical Chemists, Arlington, V.A. (USA).
- Carlen C., Darbellay C. and Gex P. (1998) Effets a long terme de la fumure et de la fréquence des coupes sur une prairie permanente en montagne. *Revue Suisse d'Agriculture* 30, 215-221.
- Calvière I. and Duru M. (1999) The effect of N and P fertilizer application and botanical composition on the leaf/stem ratio patterns in spring in Pyrenean meadows. *Grass and Forage Science* 54, 255-266
- Demarquilly C. (1970) Influence de la fertilization azotée sur la valeur alimentaire des fourrages verts. *Annales de Zootechnie* 19, 423-437.
- Peyraud J.L., Astigarraga L., Faverdin P. (1997) Digestion of fresh perennial raygrass fertilized at two levels of nitrogen by lactating dairy cows. *Animal Feed Science and Technology* 64, 155-171.
- SAS (1998) SAS/SAT User' Guide, Version 6.12. SAS Institute, Inc., Cary, NC, USA.
- Van Soest P.J., Robertson J.B. and Lewis B.A. (1991) Methods for dietary fiber, neutral detergent fiber, and non starch polysaccharides in relation to animal nutrition. *Journal of Dairy Science* 74, 3583-3597.

# Management strategies in hill pastures of Central Italy grazed by rotational-stocked cattle

D'Ottavio P. and Santilocchi R.

*Dipartimento di Scienze ambientali e delle Produzioni vegetali, Facoltà di Agraria, Università Politecnica delle Marche, Ancona, Italy*

## Abstract

The aim of this article is to examine different management strategies for beef cattle grazing in a multi-paddock rotational stocking unit on hilly areas. As the clay soils remain very wet during late spring, the beginning of the grazing period is delayed in order to avoid heavy sward damage. The management problems that occurred in 2004 (high forage waste, low duration of grazing events in the paddocks during summer and intense grazing during the summer feeding) led to the adoption of several management modifications during 2005. These changes involved: increasing the area used for hay production to minimise the spring forage surplus; the reduction of the paddock number in order to increase individual area and the duration length of grazing events in the paddocks during summer; and the use of a “summer feeding paddock” allocated to the cattle during summer periods when supplementary hay feeding is required or during long periods of rain in order to reduce the risk of sward damage.

Keywords: clay soil, hill pastures, grazing, rotational stocking, cattle

## Introduction

The continuation of farming in many rural marginal areas of Italian high-hill and mountain land is currently linked to the reintroduction of livestock breeding (Santilocchi *et al.*, 2005). Therefore, a revision of traditional management systems is required. Systems that are mainly based on grazing must be promoted, as they are able to produce positive effects on management costs, animal welfare, product quality and prevention of soil erosion, etc.

The increased spread of these systems throughout the internal hills of the Marche region, after the abandonment of the traditional cropping in the marginal areas caused by the recent CAP reform (INEA, 2004), requires the consideration of different management aspects. The main problems are due to the high diffusion of clay soils that remain very wet during late spring, therefore compelling the beginning of the grazing period to be delayed in order to avoid heavy soil and sward damage (Mulholland and Fullen, 1991; Menneer *et al.*, 2005). This research aims to identify management strategies that can be applied to minimise the negative effects caused by the delayed start of the grazing period in the hill pastures of Central Italy used by rotational-stocked cattle of local Marchigiana breed.

## Materials and methods

The experiment was performed on ‘Putido’ farm in the Fabriano municipality (Ancona province, latitude: 43°28’N, longitude: 12°54’E), on clay soils characterised by varying morphology and gradient located at a mean altitude of around 500 m a.s.l.. The average annual temperature of the study area is of 12.6 °C with a mean annual precipitation of 945 mm. The climate of the study period is represented in Figure 1.

The experiment was performed on a pasture drill-sown with a mixture of *Festuca arundinacea* (42%), *Dactylis glomerata* (22%), *Lolium perenne* (22%), *Lotus corniculatus* (8%) and *Trifolium repens* (6%) at a seed rate of 50 kg ha<sup>-1</sup>, with the addition of about 3 kg ha<sup>-1</sup> of *Medicago sativa*. The seedbed was prepared by ploughing to a depth of 40 cm in autumn 2002, grubbing and harrowing, following the distribution of N fertilizer at around 50 kg ha<sup>-1</sup>. To reduce the risk caused by high intensive early cold temperature commonly occurring in the study area, sowing was performed in spring (middle April 2003).

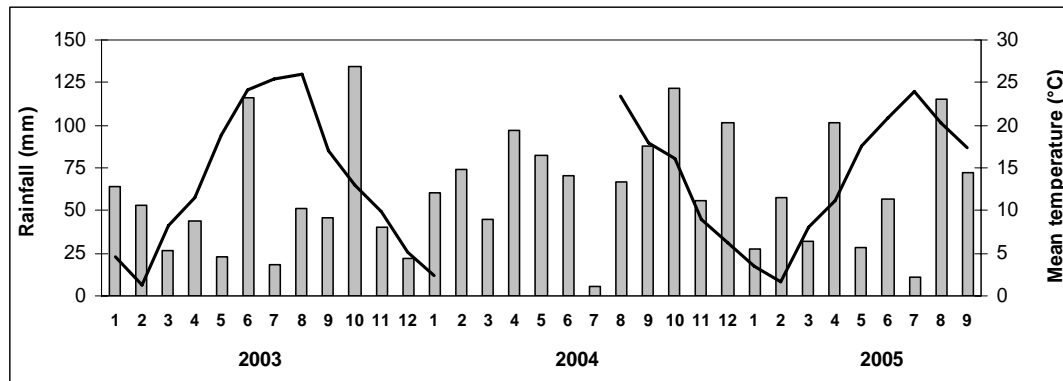

Figure 1. Mean monthly rainfall and temperature of the study period (2003-2005) recorded at Fabriano (ASSAM, 2006). Temperature data missing from 7<sup>th</sup> January to 9<sup>th</sup> August 2004.

Mainly due to the very warm and dry conditions that occurred during the following spring-summer, which caused rooting problems of the main forage species, a reseeding was performed at the beginning of September 2003, adopting the same methods and mixture used in the previous spring.

Grazing started from late spring 2004. The pasture area of about 19 ha was divided into paddocks by electric fences with the provision of 2 mobile water-points. The pasture was rotationally grazed by a herd of about 30 cows and 10 calves. The more productive areas were allocated for hay production when grass growth exceeded livestock requirements. After the harvest (generally undertaken by the end of May), these areas were introduced into the stocking rotation. In each paddock, the dry matter (DM) yield was assessed before, during and after the utilisation period throughout the 2004 and 2005 grazing periods on six 1 m<sup>2</sup>-plots randomly chosen as sample areas to estimate the available and residual forage mass.

## Results and discussion

In the 2004 grazing season, some management problems occurred. Despite the allocation of around one third of the pasture for hay production, a high level of forage wastage was recorded during the first grazing cycle (in paddock 2 up to 76%) (Figure 2), but not in the subsequent ones. This was due to the high availability of DM yield and to the advanced phenology of the main forage grasses that were not intensively grazed. These conditions were caused by the delayed grazing start, adopted to avoid intensive trampling on the pasture soil that was still very wet during May.

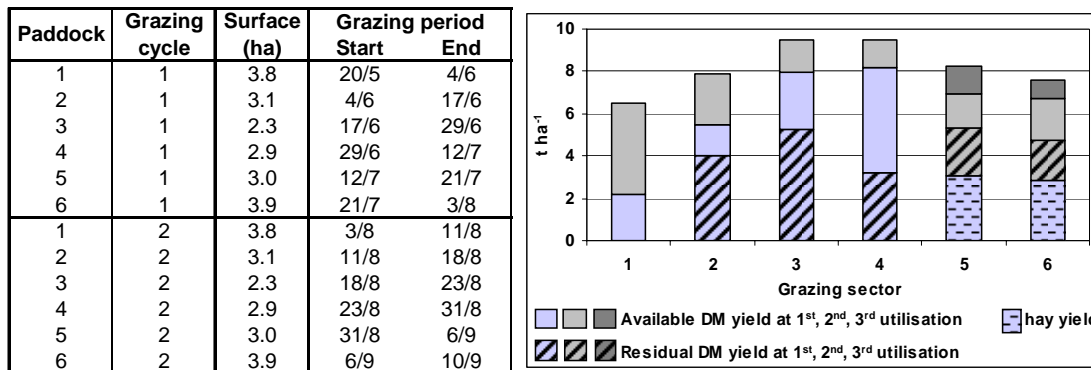

Figure 2. Available and residual forage DM yield during the 2004 grazing season.

The forage production and yield distribution had a strong influence on the grazing management. Despite the large area allocated for hay production, the first grazing cycle of 2004 had a double duration compared to the following cycles (Fig. 3) due to high forage availability.

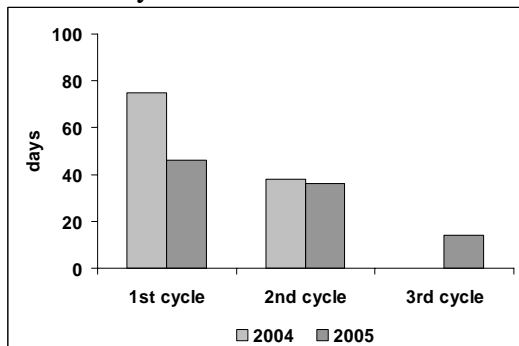

Fig. 3. Duration of grazing cycles during 2004 and 2005.

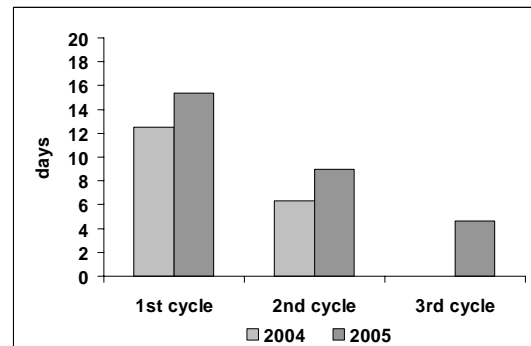

Fig. 4. Mean duration of grazing in the paddocks during the cycles of 2004 and 2005.

The forage production trend also greatly influenced the duration of the grazing events in the paddocks. They decreased on average from a duration of 12 days during the first grazing cycle to about 6 days in the second cycle (Fig. 4), thus determining the need of more frequent herd movements between the paddocks with low available forage.

Throughout the periods of low forage availability during the second grazing cycle of 2004, the hay feeding of cattle was performed by carrying the bales of hay into the paddocks. During these periods the animals still continued to graze the grass regrowth in those pastures that had very low residual forage after grazing. Based on direct observations in the present experiment and those of some other authors (Menneer *et al.*, 2005), the continuous and intensive grazing of pastures already highly utilised could compromise the long term duration of the sward due to stress conditions to which the plants are subjected.

The management problems that occurred during the 2004 grazing season (high forage waste, low duration of the grazing events in the paddocks during the second grazing cycle and intense grazing during the summer feeding) led to the adoption of several management modifications in 2005.

The changes adopted involved the increase in the area used for hay production (from 6.8 ha in 2004 to about 10.0 ha in 2005) to minimise the spring forage surplus, the reduction of the paddock number (from 6 in 2004 to 4 in 2005) in order to increase their individual area, and the use of a “summer feeding paddock” allocated to the cattle during summer periods when supplementary hay feeding is required or during long periods of rain in order to reduce the risk of sward damage. These changes gave rise to several important advantages. These included: an increased area for hay production in 2005, producing a strong reduction in the duration of the

first grazing cycle (Fig. 3) without negative consequences; an increase in herbage use efficiency and a high reduction of forage waste (Fig. 5) as the pasture was mainly grazed before an advanced phenology of the main grasses occurred; and an improvement in herd movement due to the increased paddock area adopted during the grazing cycles after the first utilisation - in 2005 the duration of grazing events in the paddocks during the second cycle were never lower than 7 days (Fig. 4) with positive effects on management costs.

The utilisation of a “summer feeding paddock” allowed a simpler feeding regime to be followed during the suspension of grazing, which avoided pasture grazing without an adequate forage production and to reduce potential sward damage also during long periods of rain during the grazing season.

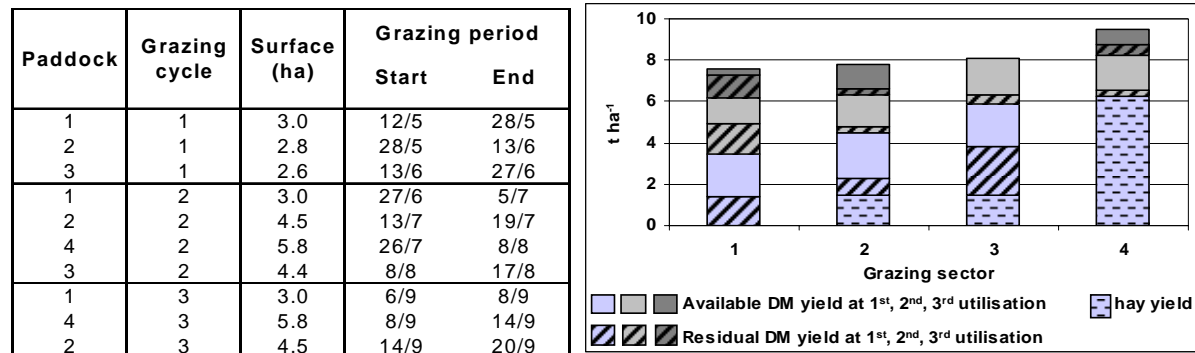

Figure 5. Available and residual forage DM yield during the 2005 grazing season.

The management adjustments adopted also allowed an increase in the hay yield (from 1.98 t in 2004 to 4.41 t in 2005) and the reaching of a level of full self-sufficiency for winter feeding, which was not achieved in 2004.

## Conclusions

The strategies adopted to minimise the negative effects caused by the delayed start of the grazing period, in order to reduce risk of sward damage during wet conditions of the soil in late spring, led to improvements in both grazing and pasture management. However, the results show that in neither year, not even during the favourable 2005 season, fresh forage was never sufficiently available to ensure continued grazing.

Based on these results and considering the pedoclimatic conditions of the study area, an increase of area should be adopted and used for hay production (the surplus of which can then be sold) along with an increase of fresh forage production for grazing during the summer period.

## References

- ASSAM (2006) Dati climatici della stazione di Fabriano. Ancona.
- Santilocchi R., Claps N. and D'Ottavio P. (2005) Aspetti gestionali del pascolamento a rotazione per l'allevamento di bovini di razza marchigiana in collina. *Proceedings of XXXVI Meeting of Società Italiana di Agronomia: "Ricerca ed innovazione per le produzioni vegetali e la gestione delle risorse agro-ambientali"*. Sept. 20-22, 2005, Foggia (Italy), 432-433.
- INEA (2004) L'impatto della riforma Fischler della PAC sull'agricoltura marchigiana - Uno studio dell'INEA per la Regione Marche. Menner J. C., Ledgard S. F., McLay C. D. A. and Silvester W. B. (2005) The effects of treading by dairy cows during wet soil conditions on white clover productivity, growth and morphology in a white clover-perennial ryegrass pasture. *Grass and Forage Science* 60, (1), 46-58.
- Mulholland B. and Fullen M. A. (1991) Cattle trampling and soil compaction on loamy sands. *Soil Use and Management*, 7 (4), 189-193.

## Grazing sulla and/or ryegrass forage for 8 or 24 hours daily. Effects on ewes feeding behaviour

Bonanno A.<sup>1</sup>, Di Grigoli A.<sup>1</sup>, Vargetto D.<sup>1</sup>, Tornambè G.<sup>1</sup>, Di Miceli G.<sup>2</sup>, Giambalvo D.<sup>2</sup>

<sup>1</sup>Dipartimento SENFIMIZO, sezione di Produzioni Animali,

<sup>2</sup>Dipartimento di Agronomia Ambientale e Territoriale, Università degli Studi di Palermo, viale delle Scienze, 90128 Palermo, Italy

### Abstract

This experiment aimed to examine the effects of the utilization of monocultures of ryegrass (R), sulla (S) or both of them (RS), and the prolongation of daily grazing from 8 h (8:00-16:00) to 24 h, evaluating behaviour, selectivity, intake and milk yield of ewes at pasture. The experiment involved 42 Comisana ewes divided into 6 homogeneous groups which, since 19<sup>th</sup> April for 42 d, continuously grazed under a stocking rate of 34 ewes/ha. Ewes involving in eating activity were higher in R and for 24-h grazing, in relation to lower intake rate. RS ewes reduced eating time and increased lying activity. During daytime, the eating gradually decreased in R and RS, whereas was constant in S; during night, eating was concentrated at sunset, especially in R. In RS, ewes showed higher selectivity for sulla than ryegrass. DM intake and corrected milk yield were favoured by S and the 24-h permanency at pasture.

Keywords: ewes, sulla, ryegrass, daily grazing time, feeding behaviour

### Introduction

The timing and duration of grazing are management practices greatly affecting the performance of animals. Accordingly, 24-h grazing showed to improve body condition of animals, reduce heat stress, increase DM intake, digestibility of selected herbage and milk production (Iason *et al.*, 1999). Despite of these benefits, manpower constraint, insecurity or damage to vegetation by animals are conditions that could suggest avoiding night grazing. In a recent experiment (Di Miceli *et al.*, 2005), positive effects emerged on milk yield from ewes when grazing sulla pasture compared with ryegrass. The sulla forage, widespread in the southern Italy, is known for its positive impact on animals productivity (Molle *et al.*, 2003), attributed to its high protein content and ratio between degradable and structural carbohydrates (Burke *et al.*, 2004), and also to its moderate presence of condensed tannins (CT) that decreases protein degradation in the rumen (Min *et al.*, 2003). In the same experiment (Di Miceli *et al.*, 2005), 24-h grazing, respecting the more common daily time of 8 h, improved milk yield from ewes utilizing sulla or ryegrass forage. However, in that study, the behaviour and feed intake of ewes were not taken into account. For this reason, another experiment was planned with the aim to investigate the effects of grazing ryegrass, sulla or both of them, for 8 or 24 h, on behaviour, selectivity, intake and milk yield of ewes at pasture.

### Materials and methods

The field experiment was carried out in a semi-arid hilly area of Sicily (37°37'N; 13°29'E; 178 m a.s.l.). Three adjacent plots, each of 4080 m<sup>2</sup>, were fenced and sown with Italian ryegrass (R) (*Lolium multiflorum* Lam. subsp. *Westerwoldicum*, var. *Elunaria*), sulla (S) (*Hedysarum coronarium*, L.) or the association of both of them (RS); in this last case, half of the plot surface was occupied by ryegrass (R<sub>S</sub>) and the other part by sulla (S<sub>R</sub>), without any

fence. A total of 42 ewes of Comisana breed, averaging  $146 \pm 55$  days in milk and  $44.6 \pm 7.3$  kg of live weight, were blocked on milk yield and live weight and randomly assigned to 6 groups. For 42 days from 19<sup>th</sup> April 2005, every plot was continuously grazed by two groups, one for 8 h, during the interval between morning and afternoon hand-milking (8:00-16:00), and the other one for 24 h. Twice weekly measurements and sampling were executed, regarding forage (available mass and botanic composition) and ewes (live weight, BCS, behaviour, selected herbage, feed intake, individual milk yield). Ewes' behavioural activities (eating, specifying if R<sub>S</sub> or S<sub>R</sub> for the RS groups, ruminating, walking, standing, lying and other) were monitored continuously over 24 h by direct observations and recorded every 15 min, both at pasture and in box for groups grazing 8 h. DM intake of ewes was assessed by the *n*-alkane technique, using simultaneous equations equating the amount of each species consumed to produce 1 kg of faeces to estimate botanical composition and digestibility (Dove and Mayes, 1991).

Analyses for DM, CP, fat, ash and structural carbohydrates were carried out on available and selected forage. The net energy for lactation (NE<sub>L</sub>) of forage was calculated using the estimated digestibility and the equations proposed by Van Soest and Fox (1992). Milk samples were analysed for fat and protein, and milk corrected for fat (6.5%) and protein (5.8%) (FPC milk) was calculated according to the equation of Pulina and Nudda (2002).

Data were statistically analysed by GLM procedure of SAS 9.1.2 software, using models including the effects of period (P), forage species (F) and interaction P\*F for data regarding available forage, and the effects of P, F, grazing time (T) and interaction F\*T for behavioural activities of ewes. For ewes performance, a randomized complete block model was used, including the effects of block, F, T and F\*T. Treatments means were compared by Student's t-test.

## Results and discussion

On average, the biomass availability was lower in R than RS and S (2.6, 4.2 vs. 4.2 t DM/ha;  $P < 0.001$ ); in RS, S<sub>R</sub> vegetation was predominant over R<sub>S</sub> (61 vs. 39 %). The contribution to RS botanic composition was higher from sulla species than other components (53.4, 30.7, 13.0 vs. 3.2 % from sulla, ryegrass, dead matter and other species, respectively).

Available herbage was more proteic and less fibrous ( $P < 0.001$ ) in S plots (14.5 and 13.9 % CP, 47.7 and 49.2 % NDF in S and S<sub>R</sub>) than in R plots (8.3 and 7.0 % CP, 55.0 and 57.0 % NDF in R and R<sub>S</sub>).

Eating and ruminating activity involved mainly R ewes (Table 1), that reduced time spent in standing and lying respect to other groups. RS ewes spent less time eating and increased lying activity, presumably because they needed a major rest as consequence of the longer movements for passing from one forage species to other one. Obviously, the longer permanency at pasture increased the incidence of ewes eating and reduced all other activities.

Table 1. Effects of forage species (R=ryegrass; S= sulla; RS=ryegrass and sulla) and grazing time (8 or 24 h) on behavioural activities of ewes over 24 h (% of observations).

	Forage species (F)			Grazing time (T)		Significance (1)			
	R	RS	S	8 h	24 h	Period	F	T	F*T
Eating	32.9 Aa	27.1 Bc	29.3 Bb	23.2	36.3	***	***	***	*
Ruminating	9.5 Aa	7.8 Bb	8.1 ABb	10.6	6.4	***	**	***	NS
Walking	1.3	1.2	1.5	1.2	1.5	***	NS	NS	NS
Standing	11.5 B	14.3 A	14.6 A	15.7	11.3	***	***	***	NS
Lying	43.4 B	46.5 A	44.8 AB	47.3	42.6	***	**	***	NS
Other	1.3 B	3.0 A	1.7 B	2.1	1.9	***	***	NS	+

(1) += $P \leq 0.10$ ; \*= $P \leq 0.05$ ; \*\*= $P \leq 0.01$ ; \*\*\*= $P \leq 0.001$ ; NS=not significant. A, B:  $P \leq 0.01$ ; a, b, c:  $P \leq 0.05$ .

With regard to eating activity (Figure 1), during daytime it decreased for R and RS groups, whereas remained constant for S ewes. This almost uniform trend of eating on sulla forage is presumably connected to its CT content that seems to favour a decreasing time spent in main meals and an increasing number of small meals (Landau *et al.*, 2000). Night grazing was concentrated at sunset, as reported in other studies (Penning *et al.*, 1997), and it was particularly intense for R 24 h ewes. In RS plot, both ewes grazing 8 h or 24 h spent more time over the day to assume sulla herbage (55.5 vs. 44.5 % in RS 8 h and 54.3 vs. 45.7 % in RS 24 h), whereas ryegrass was more preferred in the evening (59.2 vs. 40.8 %), as similarly found by Harvey *et al.* (2000); this pattern of preference was probably a result of exigency to balance diet with higher fibrous intake.

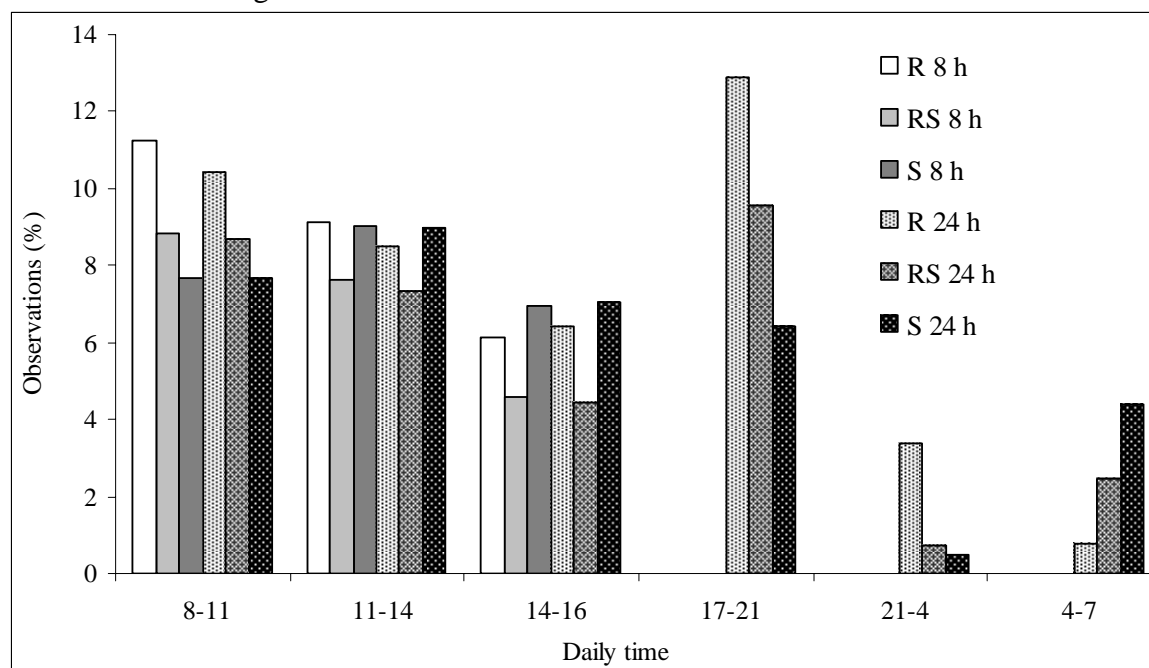

Figure 1. Effects of forage species (R=ryegrass; S= sulla; RS=ryegrass and sulla) and grazing time (8 or 24 h) on the eating activity pattern of ewes over 24 h (% of observations).

Table 2. Effects of forage species (R=ryegrass; S= sulla; RS=ryegrass and sulla) and grazing time (8 or 24 h) on botanical composition and intake of selected herbage, and FPC milk yield (LSM).

	Forage species (F)			Grazing time (T)		Significance (1)	
	R	RS	S	8 h	24 h	F	T
Ryegrass (% DM)	95.2	23.9		58.3	60.9	***	NS
Sulla (% DM)		63.3	100.0	83.6	79.7	***	NS
Other species (% DM)	4.8	12.8		5.4	6.3	***	NS
DM intake (g day <sup>-1</sup> )	1126 B	1210 B	1464 A	1184	1349	***	***
CP intake (g day <sup>-1</sup> )	175 C	243 B	373 A	249	279	***	*
NDF intake (g day <sup>-1</sup> )	498 A	413 B	388 B	401	464	***	**
EN <sub>L</sub> intake (Mcal d <sup>-1</sup> )	1.8 B	1.8 B	2.2 A	1.8	2.1	***	**
Intake rate (IR) (g DM min <sup>-1</sup> )	2.7 B	3.8 A	4.0 A	4.1	2.9	***	***
FPC milk yield (g day <sup>-1</sup> )	593 Bc	706 Ab	791 Aa	645	748	***	***

(1) \*= $P \leq 0.05$ ; \*\*= $P \leq 0.01$ ; \*\*\*= $P \leq 0.001$ ; NS= not significant. A, B, C:  $P \leq 0.01$ ; a, b, c :  $P \leq 0.05$ . (1) F\*T= NS.

According to botanical composition of selected herbage (Table 2), the RS ewes consumed more sulla than ryegrass, preference confirmed by selectivity indexes of, being 1.2 and 0.9, respectively, whereas the grazing duration had no effects. Intake of S ewes was higher in DM, CP and EN<sub>L</sub>, and lower in NDF than R ewes, being herbage selected by S grazing ewes more proteic (15.5, 19.5 vs. 25.2% DM for R, RS and S ewes;  $P < 0.001$ ) and less fibrous (NDF: 44.4, 36.1 vs. 28.2% DM for R, RS and S ewes;  $P < 0.001$ ), whereas RS group showed intermediate levels. Ewes had lower intake rates (IR) of R than RS and S, since grass was



shown to require most bites for unit mass (Orr *et al.*, 2001). In RS, IR was analogous to S as a result of decreasing IR in R<sub>S</sub> (2.4 g DM/min) and increasing IR in S<sub>R</sub> (5.1 g DM/min). Grazing 24 h instead of 8 h (Table 2) increased DM intake but reduced IR, confirming that ewes are able to regulate IR according to time allowance at pasture (Iason *et al.*, 1999). Similarly to the DM intake trend, grazing S and 24 h improved FPC milk yield (Table 2), as well as increased variation in body condition score of ewes (+0.12, +0.21 vs. +0.30 for R, RS and S,  $P < 0.01$ ; +0.12 vs. +0.31 for 8 h and 24 h,  $P < 0.001$ ).

## Conclusion

With regard to the grazed species, a major preference of ewes emerged for sulla forage, the intake of which was almost constantly diluted over diurnal grazing and occurred with higher intake rate than ryegrass forage. Moreover, sulla forage allowed the grazing ewes to increase feed intake and milk yield, demonstrating as it may constitute an exclusive forage source in the diet. When ewes grazing 24 h instead of 8 h, they spent more time for eating; accordingly, despite to lower intake rate, they increased feed intake and milk yield and improved body condition.

## Acknowledgements

Research financially supported by the Sicilian Regional Government (project SiForMe) and the Italian Ministry of University and Research (MIUR 2005075887) .

## References

- Burke J.L., Waghorn G.C., McNabb W.C. and Brookes I.M. (2004) The potential of sulla in pasture-based system. *Animal Production in Australia*, 25, 25-28
- Di Miceli G., Stringi L., Scarpello C., Iudicello P., Bonanno A. and Di Grigoli A. (2005) The timing of daily grazing on annual ryegrass or sulla forage: the effects on the milk yield and composition of Comisana ewes. *XX International Grassland Congress*, Dublin, Wageningen Academic Publishers, 511.
- Dove H. and Mayes R.W. (1991) Use of plant wax alkanes as marker substances in studies of the nutrition of herbivores: a review. *Aust. J. Agric. Res.*, 42, 913-952.
- Harvey A., Parson A.J., Rook A.J., Penning P.D. and Orr R.J. (2000) Dietary preference of sheep for perennial ryegrass and white clover at contrasting sward surface height. *Grass and Forage Science*, 55, 242-252.
- Iason G.R., Mantecon A.R., Sim D.A., Gonzalez J., Foreman E., Bermudez F.F. and Elston D.A. (1999) Can grazing sheep compensate for a daily foraging time constraint? *Journal of Animal Ecology*, 68, 87-93.
- Landau S., Silanikove N., Nitsan Z., Barkai D., Baram H., Provenza P.D. and Perevolotsky A. (2000) Short-term changes in eating patterns explain the effects of condensed tannins of feed intake in heifers. *Appl. Anim. Beh. Sci.* 69, 199-213.
- Min B.R. Barry T.N., Attwood G.T. and McNabb W.C. (2003) The effect of condensed tannins on the nutrition and health of ruminants feed fresh temperate forages: a review. *Animal Feed Science and Technology*, 106, 3-19.
- Molle G., Decandia M., Fois N., Ligios S., Cabiddu A. and Sitzia M. (2003) The performance of Mediterranean dairy sheep given access to sulla (*Hedysarum coronarium L.*) and annual ryegrass (*Lolium rigidum Gaudin*) pastures in different time proportions. *Small Ruminant Research*, 49, 319-328.
- Orr R.J., Penning P.D., Rutter S.M., Champion R.A., Harvey A. and Rook A.J. (2001) Intake rate during meals and meal duration for sheep in different hunger states, grazing grass or white clover swards. *Applied Animal Behaviour Science*, 75, 33-45.
- Penning P.D., Newman J.A., Parsons A.J., Harvey A. and Orr R.J. (1997) Diet preferences of adult sheep and goats grazing ryegrass and white clover. *Small Rum. Res.*, 24, 175-184.
- Pulina G. and Nudda A. (2002) Milk production. In "Dairy sheep feeding and nutrition", Pulina G. Ed., Avenue media, Bologna, Italy, 11-27.
- Van Soest P.J. and Fox D.G. (1992) Discounts for net energy and protein - fifth revision. *Proceed. Cornell Nutrition Conference*, Ithaca, New York, 40-68.

# Herbage and milk productivity and quality when grazing different legumes and herbs

Eriksen J.<sup>1</sup>, Sjøgaard K.<sup>1</sup>, Kristensen T.<sup>1</sup>, Fretté X.C.<sup>2</sup>, Wiking L.<sup>2</sup> and Holm Nielsen J.<sup>2</sup>.

<sup>1</sup>Department of Agroecology, Aarhus University, PO Box 50, 8830 Tjele, Denmark

<sup>2</sup>Department of Food Science, Aarhus University, PO Box 50, 8830 Tjele, Denmark

## Abstract

In order to evaluate how different legumes and herbs affect the quality of organic milk, a grazing study was performed at the organic research station Rugballegaard with 48 dairy cows. Swards with Lucerne (*Medicago sativa*), red clover (*Trifolium pratense*), white clover (*Trifolium repens*) and white clover together with chicory (*Cichorium intybus*), respectively, were established in 2005 together with perennial ryegrass (*Lolium perenne*) in two replicates. The study was carried out in 2006 over three two-week periods during the season. Generally, the proportion of legumes and chicory was high in the four species mixtures. Sward composition highly affected grazing behaviour. Sward height measurements indicate that the white clover mixture was eaten without much selection, the red clover was partly avoided in some areas, and in contrast lucerne seemed to be eaten selectively. In chicory swards selection occurred in a patchy way.

Keywords: legumes, herbs, grazing, sward structure

## Introduction

It is known that the botanical composition of the fodder affects the composition of milk and subsequent the flavour (Collomb *et al.*, 2002). Pasture contains high levels of  $\alpha$ -tocopherols and carotenoids, and an on-going survey of the composition of organic milk in Europe (QLIF-project) indicates that it is possible to reach extremely high levels of conjugated linoleic acids,  $\alpha$ -tocopherols and carotenoids, which all are expected to contribute positively to the nutritional value, when dairy cows are entirely fed on pasture (Nielsen, pers. comm.).

The hypothesis of this work was that it is possible to produce milk with a distinct flavour and composition using feeding concepts with high levels of pasture. Specifically, it was the aim to analyse the effect on herbage production, composition, intake, selection and milk quality of large proportions of different legumes and herbs in the pasture. Here are presented only results on herbage composition, productivity and selection during grazing. Kristensen *et al.* (this issue) will report on milk productivity and quality.

## Materials and methods

A grazing study was performed at the organic research station Rugballegaard with 48 dairy cows. Swards with Lucerne, red clover, white clover and white clover together with chicory, respectively, were established in 2005 together with perennial ryegrass in two replicate paddocks. The study was carried out in 2006 over three two-week periods during the season, where the herd was split into four groups before each period according to stage of lactation, parity and milk yield. The cows grazed the two replicates alternately with one day in each. The swards were unfertilized and irrigated at high drought stress. Before each period the sward biomass was determined and the grazing area adjusted to equal herbage allowance. Registrations were made on herd and sward productivity, herbage quality, botanical

composition and intake during grazing with special attention to selection. Sward height was determined before and after each grazing period by 50 and 100 measurement, respectively, using a rising-plate meter. Sward productivity was estimated indirectly in an area fenced off during the period. At start and after one week of grazing the herbage mass and the botanical composition were determined in 0.5 m<sup>2</sup> samples in the grazed area and in the fenced area. Furthermore the grassland species were analysed in order to calculate the feeding value and for components affecting the quality of the milk including fatty acid composition, tocopherols and carotenoids and further for content of potential flavour compounds that can be transferred to the milk (not reported here). The cows were on pasture 20 hours daily and supplemented with 6.2 kg dry matter cow<sup>-1</sup> day<sup>-1</sup> (oats 82%, hay 16%, mineral mix 2%) fed restrictively twice daily after milking.

## Results and discussion

### *Herbage composition, productivity and selection during grazing*

Generally, the proportion of legumes and chicory was high in the four species mixtures included in the study (Table 1). The exception was only 12% lucerne in the two-week period in June caused by a too short rest period from the previous period in May. Lucerne requires a longer rest period in-between grazing than the two weeks offered in this experiment.

Table 1. Proportion of the main component of the species mixtures and herbage mass at the beginning of each period; and growth rate during the 2-week experimental period.

Sward type	Proportion of main component (%)			Herbage mass kg DM ha <sup>-1</sup>			Herbage growth rate kg DM ha <sup>-1</sup> d <sup>-1</sup>		
	May	Jun.	Aug.	May	Jun.	Aug.	May	Jun.	Aug.
White clover mix	80	46	41	1799	1670	904	134	109	43
Red clover mix	68	47	42	2383	2178	907	82	122	57
Lucerne mix	27	12	39	2476	1249	1462	106	124	11
Chicory mix	72	52	39	1738	1609	886	123	102	62

Differences in sward structure indicated different grazing behaviour of cows on different sward types (Fig. 1). Prior to grazing, sward height did not vary much except in the lucerne mixture. After two weeks of grazing the sward with white clover still had a relatively even height, lucerne was much more even than before grazing and both the red-clover and the chicory mixture were more variable in height than before. Especially the chicory mixture was very unevenly grazed. Altogether the height measurements indicate that the white clover mixture was eaten without much selection, the red clover was partly avoided in some areas, and in contrast lucerne seemed to be eaten selectively. In chicory swards selection occurred in a patchy way in the May and June grazing periods as the sward was grazed down in some patches and in others it was untouched. We could not explain this selection that was outside that of species.

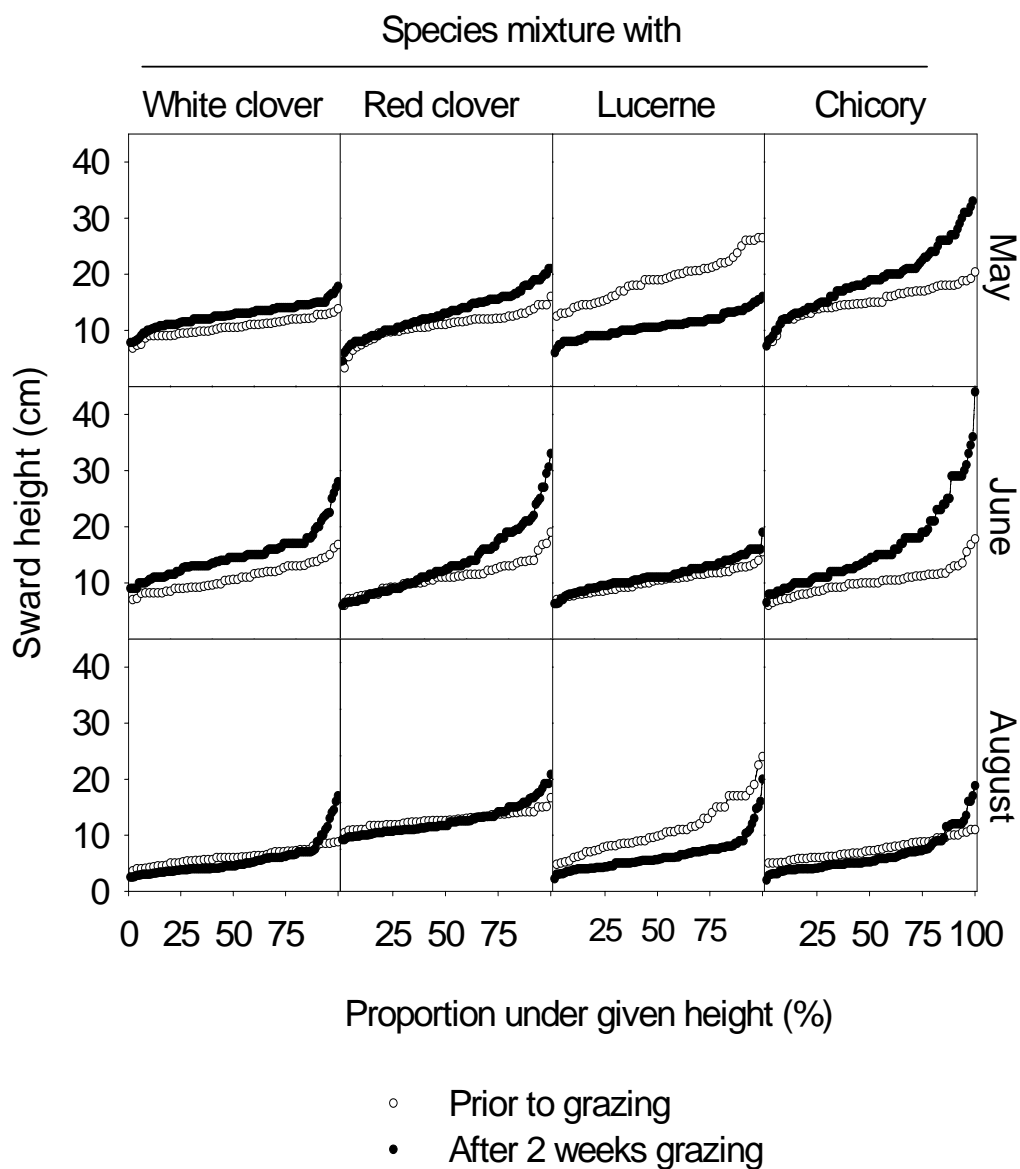

Figure 1. Sward structure of the four species mixtures previous to and at the end of each two-week grazing period. Percent of measurements below a given height is shown in relation to the height.

## Conclusions

Here were presented some results from an ongoing study on how grazing of different legumes and herbs affects the quality of organic milk. The results of the grass crop are discussed in this paper. Generally, the proportion of legumes and chicory was high in the four species mixtures. Sward composition highly affected grazing behaviour: the white clover mixture was eaten without much selection, the red clover was partly avoided in some areas, and in contrast lucerne seemed to be eaten selectively. Analysis of the quality of herbage and milk in this study are in progress.

## References

Collomb M., Buetikofer U., Sieber R, Jeangros B. and Bosset J.O. (2002) Correlation between fatty acids in cow's milk fat produced in lowlands, mountains and highland of Switzerland and botanical composition of the fodder. *International Dairy Journal* 12: 661-666.

# Liveweight gains were similar in steers grazing perennial ryegrass cultivars bred for elevated or normal concentrations of water-soluble carbohydrates

Black A.D., O'Kiely P. and Moloney A.P.

*Teagasc, Grange Beef Research Centre, Dunsany, County Meath, Ireland*

## Abstract

Perennial ryegrass (*Lolium perenne* L.) cultivars with high concentrations of water-soluble carbohydrates (WSC) are potentially beneficial to enhance the efficiency of dietary nitrogen (N) use by ruminant livestock. However, there is little information about the performance of beef cattle grazing high WSC cultivars. This study examined the performance of steers grazing the perennial ryegrass cultivar AberDart, bred for an elevated concentration of WSC, compared to Fennema, an intermediate WSC perennial ryegrass, in Ireland from April to September, 2004. There were no differences ( $P > 0.05$ ) in mean liveweight gains ( $1.01$  v.  $0.98$  kg day<sup>-1</sup>) and carcass weights ( $337$  v.  $336$  kg) between the AberDart and Fennema treatments. The corresponding mean WSC concentrations were  $151$  and  $139$  g kg DM<sup>-1</sup>, organic matter digestibility values were  $767$  and  $758$  g kg<sup>-1</sup>, crude protein concentrations were  $189$  and  $187$  g kg DM<sup>-1</sup>, pre-grazing herbage masses were  $2584$  and  $2775$  kg DM ha<sup>-1</sup>, and herbage allowances were  $15.4$  and  $13.5$  kg DM steer<sup>-1</sup> d<sup>-1</sup>. The results show that the small differences in the WSC concentrations between AberDart and Fennema were not sufficient to cause any measurable differences in the performance of grazing beef steers.

Keywords: *Lolium perenne*, water-soluble carbohydrate, grazing, steers, liveweight gain

## Introduction

Perennial ryegrass (*Lolium perenne* L.) cultivars bred to express high concentrations of water-soluble carbohydrates (WSC) have been evaluated in Europe for sustainable livestock production systems (Südekum, 2005). High concentrations of forage WSC help to capture nitrogen (N) released from forage proteins degraded in the rumen. This potentially reduces the amount of N excreted in the urine (Miller *et al.*, 2001) which would be environmentally beneficial. There are also reports of increases in liveweight gains in lambs (Lee *et al.*, 2001) and beef steers (Marley *et al.*, 2005a) and milk yields in dairy cows (Miller *et al.*, 2001) when fed high WSC cultivars compared to intermediate WSC cultivars. High WSC cultivars have been developed in the UK where they have expressed 10-60% higher WSC concentrations compared to standard UK cultivars (Lee *et al.*, 2001; Miller *et al.*, 2001; Marley *et al.*, 2005a; Marley *et al.*, 2005b). However, other reports suggest that the high WSC trait may not be consistently expressed (Parsons *et al.*, 2004) or may not result in livestock production benefits (Marley *et al.*, 2005b) in certain environmental and grazing management conditions.

The objective of this study was to examine the liveweight gains and carcass weights of beef steers when grazing the perennial ryegrass cultivar AberDart, bred to express elevated concentrations of WSC, compared to a control, Fennema, with an intermediate concentration of WSC, under rotational grazing in Ireland.

## Materials and methods

The experiment was conducted at Grange Beef Research Centre, County Meath, Ireland (53°30'N, 6°40'W, 92 m above sea level), on an imperfectly drained brown earth soil with a loam to peat-loam texture. Long-term (1971-2001) mean (s.d.) annual rainfall was 849 (81.6) mm and daily air temperature was 9.1 (0.64) °C. AberDart and Fennema were in September 2001 each sown separately in 1.29-2.48 ha plots arranged in a block design with seven replicates. Swards were maintained by cutting and grazing in 2002 and 2003. In March 2004, four plots of each cultivar were divided into three subplots using electric fences.

Sixty-two Charolais or Limousin crossbred steers, with a mean (s.d.) age of 24 (0.6) months and live weight of 487 (36.6) kg, were blocked into 31 uniform live weight and breed groups and one steer from each block was assigned at random to each cultivar, giving two balanced groups of 31 steers. However, early in the experiment one steer was removed from the AberDart group due to illness and was not replaced. All steers were treated for parasites at the start of the experiment. Steers rotationally grazed the plots from 28 April to 28 September, 2004. Sward height was measured before and after grazing using a rising plate meter. Steers grazed the swards to a height of *ca.* 6-7 cm (usually 3-5 days residence time per subplot) before moving to the next subplot in the rotation. Grazing area adjustments were used to alter rotation length to maintain the pre-grazing height of the sward at *ca.* 12-16 cm. Plots excluded from the grazing rotation were cut for silage. Fertiliser (0.27 N, 0.025 P, 0.05 K) at 40 kg ha<sup>-1</sup> was generally applied after each plot was grazed or cut for silage.

All steers were weighed every 3 to 4 weeks until the day before slaughter on 29 September. The liveweight gain of each steer was calculated as the difference between successive live weights divided by the number of days between weight measurements and plotted at the mid-point date of each measurement interval. Herbage mass was estimated before grazing by cutting four 1.5 m x 5.0 m strips to 4 cm above ground level using a Haldrup plot harvester. These samples were weighed and a sub-sample (100 g) dried at 98°C (16 h) to determine dry matter (DM) concentration, pre-grazing herbage mass (kg DM ha<sup>-1</sup>) and pre-grazing herbage allowance (kg DM steer<sup>-1</sup> d<sup>-1</sup>) estimated above 4 cm. Post-grazing herbage mass (kg DM ha<sup>-1</sup>) was estimated from relationships between sward height and herbage mass. Chemical composition was determined from a second sub-sample (*ca.* 200 g) of the cut herbage dried at 40°C (48 h) and ground in a mill with a 1 mm sieve. The milled samples were bulked within each plot and used to determine concentrations of WSC (Lee *et al.*, 2001), *in vitro* organic matter digestibility (OMD) (Tilley and Terry, 1963), crude protein (total N × 6.25; AOAC, 1990) and ash (muffle furnace at 550°C for 5 h).

The null hypothesis that there were no differences in mean liveweight gains and carcass weights between the two cultivars was tested using ANOVA and the PROC GLM procedure of SAS, with a model that accounted for treatment and blocking (Littell *et al.*, 2002). Differences in mean herbage chemical composition, herbage mass and intake between cultivars were tested using *z* tests. Assumptions of normality and homogenous variance were confirmed.

## Results and discussion

There were no significant differences ( $P > 0.05$ ) in the mean liveweight gains and carcass weights between the steers grazing AberDart and Fennema (Table 1, Figure 1a). There were also no significant differences ( $P > 0.05$ ) in the mean chemical composition between the two cultivars, with only a 0.09 increase (12 g kg DM<sup>-1</sup>) in the mean WSC concentration of AberDart relative to Fennema. There were small differences ( $P < 0.05$ ) in the mean DM concentration, pre-grazing herbage mass and pre-grazing sward height, but the values were

greater for Fennema than AberDart and did not result in any significant differences ( $P > 0.05$ ) in herbage allowance, post-grazing sward height, or post-grazing herbage mass between the two cultivars. Therefore, these data do not support the hypothesis that an increase in the liveweight gain of steers is achieved when grazing the perennial ryegrass cultivar AberDart compared to Fennema.

Table 1. Animal performance, chemical composition and herbage supply characteristics of the perennial ryegrass cultivars AberDart and Fennema grazed by steers at Grange Beef Research Centre, Ireland, from 28 April to 28 September, 2004.

Variable	AberDart	Fennema	s.e.d.	F or z	P value
Liveweight gain ( $\text{kg d}^{-1}$ )	1.01	0.98	0.038	0.44	NS
Final live weight (kg)	639	637	10.9	0.04	NS
Carcass weight (kg)	337	336	6.2	0.06	NS
Dry matter ( $\text{g kg}^{-1}$ )	181	190	0.3	3.01	<0.01
Water-soluble carbohydrates ( $\text{g kg DM}^{-1}$ )	151	139	14.3	0.86	NS
Organic matter digestibility ( $\text{g kg}^{-1}$ )	767	758	11.1	0.87	NS
Crude protein ( $\text{g kg DM}^{-1}$ )	189	187	7.2	0.25	NS
Ash ( $\text{g kg DM}^{-1}$ )	99	96	2.0	1.07	NS
Pre-grazing herbage mass ( $\text{kg DM ha}^{-1}$ )	2584	2775	91.6	2.09	<0.05
Post-grazing herbage mass ( $\text{kg DM ha}^{-1}$ )	1127	1134	27.0	0.29	NS
Pre-grazing sward height (cm)	14.7	15.8	0.35	2.94	<0.01
Post-grazing sward height (cm)	6.6	6.7	0.15	0.43	NS
Herbage allowance ( $\text{kg DM steer}^{-1} \text{d}^{-1}$ )	15.4	13.5	1.39	1.36	NS

s.e.d., standard error of the difference between means; for animal variables,  $F_{\text{critical}} = 4.00$ , for all other variables,  $z_{\text{critical}} = 1.96$  ( $P = 0.05$ ); NS, not significant.

The non-significant difference in the mean WSC concentration between AberDart and Fennema was not sufficient to cause any differences in steer performance. Lee *et al.* (2001) reported increases in liveweight gains of lambs when the difference in the mean WSC concentration of their two experimental perennial ryegrass cultivars was approximately 40-50  $\text{g kg DM}^{-1}$ , but not when the difference was small (8  $\text{g kg DM}^{-1}$ ). Marley *et al.* (2005a) reported increases in liveweight gains of beef steers in the UK when grazing 'upland' swards of AberDart and Fennema with a difference in mean WSC concentration of 22-26  $\text{g kg DM}^{-1}$ . In our study, both cultivars were able to meet the nutrient requirements of steers with a mean liveweight gain of 1.0  $\text{kg d}^{-1}$ , and both cultivars produced about 700  $\text{kg}$  of live weight  $\text{ha}^{-1}$ .

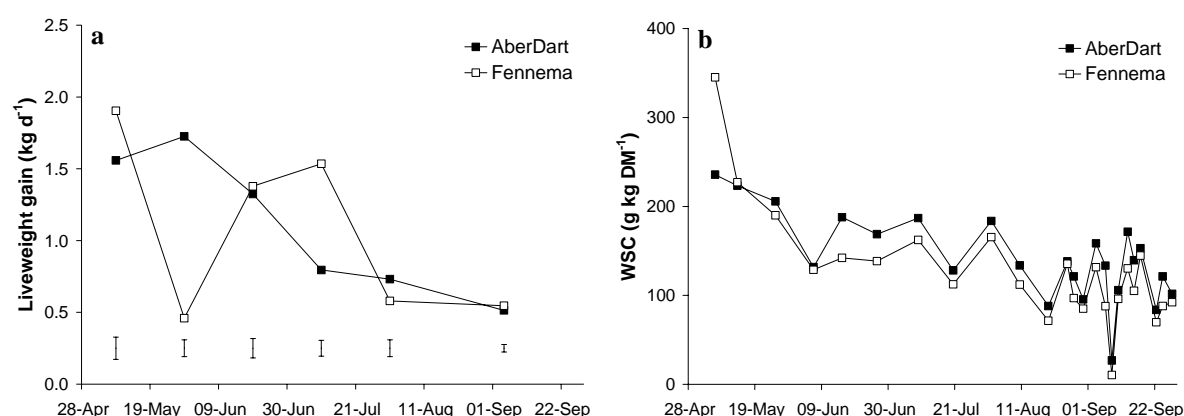

Figure 1. Mean (a) liveweight gains of steers and (b) concentrations of forage water-soluble carbohydrates (WSC) from perennial ryegrass cultivars AberDart and Fennema grazed at Grange Beef Research Centre, Ireland, from 28 April to 28 September, 2004. Bars represent standard error of the difference between means.

The concentrations of WSC measured in AberDart and Fennema varied throughout the grazing season, but WSC concentrations and liveweight gains tended to be higher in spring than in summer/autumn (Figures 1a and 1b). In UK studies, the greatest differences in WSC concentrations between high WSC cultivars and controls were expressed in leaves produced throughout spring and early summer (e.g. Orr *et al.*, 2003; Lee *et al.*, 2001). In our study, the differential in WSC between the cultivars was inconsistent and, with the exception of the first datum for Fennema (possibly an outlier), ranged between -4 and +46 g kg DM<sup>-1</sup> (Figure 1b). This was unexpected since AberDart was developed in Wales, which has a cool, moist climate similar to County Meath, Ireland. A consistent expression of the high WSC trait, particularly in summer and autumn, is required if high WSC perennial ryegrass cultivars are to have any preferential relevance to pasture-based beef production systems in Ireland.

## Conclusion

The small difference in mean WSC concentration between the perennial ryegrass cultivars AberDart and Fennema in grazed swards was not sufficient to cause a measurable difference in the performance of beef steers. This was associated with similar levels of herbage supply for the two cultivars, and a similar chemical composition.

## Acknowledgements

EU Framework V (QLK5-CT-2001-0498) for partial funding.

## References

- AOAC (Association of Official Analytical Chemists) (1990) *Official methods of Analysis*, 15<sup>th</sup> edn. Arlington, Virginia, USA: AOAC International.
- Lee M.R.F., Jones E.L., Moorby J.M., Humphreys M.O., Theodorou M.K., MacRae J.C. and Scollan N.D. (2001) Production responses from lambs grazed on *Lolium perenne* selected for an elevated water-soluble carbohydrate concentration. *Animal Research*, 50, 441-449.
- Littell R.C., Stroup W.W. and Freund R.J. (2002). *SAS for Linear Models*, 4<sup>th</sup> edn. Cary, NC, USA: SAS Institute Inc.
- Marley C.L., Davies D.A., Vale J.E., Evans J.G., Scollan N.D., Moorby J.M., MacRae J.C. and Theodorou M.K. (2005a) Effects of upland pastures sown with two contrasting *Lolium perenne* varieties on the performance of beef steers when compared to steers grazing permanent pastures. *Proceedings of the British Society of Animal Science, York, UK, 2005*, pp. 194.
- Marley C.L., Fisher W.J., Davies D.W.R., Moorby J.M., MacRae J.C. and Theodorou M.K. (2005b) Effect of two contrasting ryegrass varieties and their management on the performance of finishing lambs. *Proceedings of the British Society of Animal Science, York, UK, 2005*, pp. 142.
- Miller L.A., Moorby J.M., Davies D.R., Humphreys M.O., Scollan N.D., MacRae J.C. and Theodorou M.K. (2001) Increased concentration of water-soluble carbohydrate in perennial ryegrass (*Lolium perenne* L.): milk production from late-lactation dairy cows. *Grass and Forage Science*, 56, 383-394.
- Orr R.J., Cook J.E., Champion R.O., Penning P.D. and Rook A. (2003) Intake characteristics of perennial ryegrass varieties when grazed by sheep under continuous stocking management. *Euphytica*, 134, 247-260.
- Parsons A.J., Rasmussen S., Xue H., Newman J.A., Anderson C.B. and Cosgrove G.P. (2004) Some 'high sugar grasses' don't like it hot. *Proceedings of the New Zealand Grassland Association*, 66, 265-271.
- Südekum K.-H. (2005) N flows and N efficiency in legume-based systems – implications for ruminant nutrition. In: Wachendorf M., Helgadóttir Á. and Parente G. (eds) *Sward dynamics, N-flows and forage utilisation in legume-based systems. Proceedings of the 2<sup>nd</sup> COST 852 workshop, Grado, Italy, 2005*, 211-218.
- Tilley J.M.A. and Terry R.A. (1963) A two-stage technique for the *in vitro* digestion of forage crops. *Journal of the British Grassland Society*, 18, 104-111.



## **Milk production and quality when feeding different legumes and herbs either as pasture or as silage.**

Kristensen, T.<sup>1</sup>, Eriksen, J.<sup>1</sup>, Søgaard, K.<sup>1</sup>, Fretté, X.C.<sup>2</sup>, Wiking, L.<sup>2</sup>, Holm Nielsen, J.<sup>2</sup> and Vestergaard, J.<sup>3</sup>

<sup>1</sup>*Department of Agroecology and Environment, University of Aarhus, Faculty of Agricultural Sciences, PO Box 50, 8830 Tjele, Denmark. Phone: +45 8999 1233. Fax: 8999 1200.*

<sup>2</sup>*Department of Food Science, University of Aarhus, Faculty of Agricultural Sciences, PO Box 50, 8830 Tjele, Denmark.*

<sup>3</sup>*Department of Food Science, University of Copenhagen, Faculty of Life Sciences, Rolighedsvej 30, DK-1958, Frederiksberg, Denmark*

### **Abstract**

Swards with lucerne (*Medicago sativa*), red clover (*Trifolium pratense*), white clover (*Trifolium repens*) and white clover together with chicory (*Cichorium intybus*) were established in 2005 together with perennial ryegrass (*Lolium perenne*). The effect on intake, milk production and quality of the four different pastures when supplemented with concentrates (6.2 kg DM), was examined over three two-week periods during the summer and the effect of the same types of herbage as silage supplemented with concentrates and maize silage (12.2 kg DM) was examined during one two-week period in the following winter using 4 times 12 Holstein Frisian cows in both experiments. Milk yield was recorded individually, and milk samples for analysis of composition were collected, over one day three times during each feeding period. Results of intake, milk production and composition showed clear effects of herbage type on several parameters.

Keywords: Lucerne, red clover, white clover, chicory, dairy cows, milk composition

### **Introduction**

It has been shown that the use of legumes, both under conventional and organic production systems, is essential for creating a profitably dairy production (Doyle and Topp, 2004). Besides this have the legume-based grazing systems the ability to increase the efficiency of nitrogen use at farm level (Rochon *et al.*, 2004), stimulate the silage intake and milk yield in the herd (Dewhurst *et al.*, 2003) and legumes are positive selected by grazing livestock (Rutter (2006). Moreover, it has been reported that milk from cows fed grass silage has a different flavour compared to the milk from cows fed maize silage (Frandsen *et al.* 2003) and Collomb *et al.* (2002) has described how the botanical composition of the fodder affects the composition of the milk and subsequent the flavour. A recent study by Lund-Nielsen *et al.* (2005) showed that the composition of organically produced Danish milk differs significantly from the conventionally produced milk with regard to fatty acid composition and the content of antioxidants. These identified differences in composition of organic and conventional produced milk are suggested to be a result of differences in the feeding regimes used in the present production of organic and conventional milk in Denmark, where maize products are becoming the major feed components in the conventional dairy production. Preliminary studies on feeding of dairy cows by either maize silage or grass silage clearly show that milk from cows fed grass silage contains a significantly higher concentration of alfa-tocopherols and carotenoids. At the same time the milk based on feeding grass silage also possesses a

higher concentration of unsaturated fatty acids, which make the derived dairy products more susceptible to oxidation (Havemose *et al.* 2004).

The hypothesis of this work was that it is possible to produce milk with a distinct flavour and composition by feeding high levels roughage both as pasture and silage. Specifically, it was the aim to analyse the effect on milk production and milk quality of large proportions of different legumes and herbs either in the pasture or in the grassland before harvesting as silage. In this paper the production data is presented.

## Material and methods

Swards with lucerne (*Medicago sativa*), red clover (*Trifolium pratense*), white clover (*Trifolium repens*) and white clover together with chicory (*Cichorium intybus*), respectively, were established with spring barley as cover crop in 2005 together with perennial ryegrass (*Lolium perenne*) in two replicates. No fertilizer was given to the area, other than the deposition of manure during grazing. The grazing study was carried out in 2006 over three two-week periods during the season (May, June and August) with identical herbage allowance by adjustment of the area before start of the grazing period. Forty-eight Holstein Frisian cows were split into four groups of 12 cows before each period according to stage of lactation, parity and milk yield. Pasture was supplemented with 6.2 kg drymatter (DM) cow<sup>-1</sup> day<sup>-1</sup> (oats 82%, hay 16%, mineral mix 2%) fed in equally amounts twice daily after milking.

After the end of the first period the remaining area of herbage (buffer area not used for grazing) was ensiled in bales, and used in an indoor experiment during a two-week period the following winter. The herbage was wilted for one day before ensiled in bales. The feeding was planned to provide identical proportions of each feedstuff (oats 25%, blue lupin 13%, maize silage 14%, hay 3%, mineral mix 1% and 44% of DM from one of the four silage type under investigation) in the total mixed ration fed *ad libitum*. The mix was defined in kg of each component based on the dry matter content found before the trial, for silage in average of samples from five bales.

In both studies individual milk samples were collected three times during the last week of each feeding period. Results from the summer period are presented as average of the three periods, although there were some variations in sward characteristics, but the variation in milk production was affected by season only for few parameters. Detailed information about the sward (composition, selection and growth rate) is given by Eriksen, *et al.* (2007).

## Results and discussion

The cows, 30.7 ± 5.8 kg energy corrected milk (ECM) and 140 ± 68 days in milk at the beginning of the experiments were at pasture for 20 hours daily during the three summer periods. Milk yield was unaffected by treatment and at the same high level in all three periods (Table 1). The milk protein content was also identical between treatments on average for the three periods, but with a general reduction during the season (data not shown). Milk-urea content was clearly lowest in the milk from the cows grazing chicory irrespectively of period, while the ranking of the other treatments changed during the season, with red clover being highest in the first two periods and white clover in the last period.

Table 1. Composition of the four sward types and the effect on milk production and composition in average of three grazing periods.

	Sward type – main component				SEM
	White clover	Red clover	Lucerne	Chicory	
<i>Sward</i>					
Main component, % of DM	56	52	26	54	
Herbage mass, kg DM ha <sup>-1</sup>	1458	1823	1729	1411	
Crude protein, % in DM	23.2	24.0	22.0	18.2	
<i>Milk production</i> <sup>1</sup>					
Milk, kg	31,9	31,7	31,0	31,5	0,6
Protein, g	1049	1038	1009	1023	17
Fat, g	1186	1182	1164	1218	29
<i>Milk content</i>					
Protein, %	3.31	3.28	3.28	3.26	0.03
Fat, %	3.78	3.72	3.80	3.90	0.09
Urea, mmol	5.43a	5.50a	5.05a	2.77b	0.16
Somatic cell count, 1000 (log)	4.59	4.69	4.58	4.73	0.13

ab: Different letters indicate significant ( $P < 0,05$ ). Figures are lsmeans model  $y = \text{yield at start, parity, days in milk, period and treatment}$

1: Pasture supplemented with 6,2 kg DM.

Table 2. Quality of the silage from four sward types and the effect on milk production and composition.

	Silage type – main component				– SEM white clover
	White clover	Red clover	Lucerne	Chicory	
<i>Silage</i>					
Dry matter, average %	42	22	39	26	
” , min-max %	34 – 55	19 – 24	26 – 53	24 – 28	
DOM, %	78.0	76.0	79.6	79.9	
Crude protein, % in DM	15.6	22.3	17.6	15.6	
pH	4.3	4.3	4.2	4.1	
<i>Feeding – mixed ration</i>					
Energy, NEL kg DM <sup>-1</sup>	6.64	6.59	6.70	6.63	
Crude protein, % in DM	16.7	20.0	17.7	16.7	
Dry matter intake, kg cow <sup>-1</sup>	25.3	21.9	27.1	24.5	
Silage, % of DM intake	54	46	57	48	
<i>Milk production</i>					
Milk, kg	30.2	31.5	29.3	31.5	0.9
Protein, g	980	982	983	1030	34
Fat, g	1211	1204	1316	1222	52
<i>Milk content</i>					
Protein, %	3.30	3.32	3.37	3.28	0.03
Fat, %	3.99a	3.98a	4.39b	3.89a	0.08
Urea, mmol	5.43a	6.86b	5.86a	4.72c	0.23
Somatic cell count, 1000 (log)	4.88	4.83	5.16	4.41	0.25

ab: Different letters indicate significant ( $P < 0,05$ ). Figures are lsmeans model  $y = \text{yield at start, parity, days in milk and treatment}$

During feeding in the winter experiment it was observed that there was some variation in the dry matter content both within and between bales of different type herbage (Table 2). The actual proportion of DM, based on daily amount used and the average dry matter content from every fourth bale during the experiment, showed some variation from the plan, as the amount of DM from the four type of silage under investigation varied from 46 to 57% of the DM intake. The total DM intake was from 21.9 kg when red clover was used to 27.1 kg DM when lucerne was the silage type given. The protein content in DM for the rations varied from 16.7% in both the white clover and chicory rations to 20.0% in the red clover ration, due to the high content in red clover silage compared to the three other types. The production from the cows (29.8 +- 6.3 kg ECM and 127+- 78 days in milk at start of the experiment) was

unaffected by the variation in type of silage. The milk protein content was also identical between treatments, while milk fat content was significantly higher in the milk from the cows fed lucerne than the three other types of roughage. As in the pasture period, milk-urea content was lowest in the milk from the cows given chicory.

The feed conversion in terms of kg energy corrected milk per kg silage DM was 2.2; 3.0; 1.9 and 2.6 in each of the four treatments respectively, which are at the same level as found by Dewhurst *et al.* (2003), but the variation was larger and the ranking of the type of legumes is different. The variation in efficiency is primarily a result of large variation in DM intake, which is calculated with some uncertainty due to the problem with variation in DM content between the bales.

## Conclusion

These experiments confirmed the positive perspective for high milk yield from several grass-legumes based silages and has also given positive indication for development of systems with grazing of lucerne and red clover based pastures.

## References

- Collomb M., Buetikofer U., Sieber R., Jeangros B. and Bosset J.O. (2002) Correlation between fatty acids in cow's milk fat produced in lowlands, mountains and highland of Switzerland and botanical composition of the fodder *International Dairy Journal* 12, 661-666
- Dewhurst R.J., Fisher W.J., Tweed J.K.S. and Wilkins R.J. (2003) Comparison of grass and legume silage for milkproduction. 1. Production responses with different levels of concentrates. *J. Dairy Sci.* 86, 2598-2611.
- Doyle C.J. and Topp C.F.E. (2004) The economic opportunities for increasing the use of forage legumes in north European livestock systems under both conventional and organic management. *Renewable Agriculture and Food Systems*, 19, 15-22
- Eriksen J., Sjøgaard K., Kristensen T., Fretté X.C., Wiking L. and Holm Nielsen J. (2007) Herbage and milk productivity and quality when grazing different legumes and herbs. *This Volume*.
- Frandsen L.W., Dijksterhuis G., Brockhoff P., Nielsen J.H. and Martens M. (2003) Subtle Differences in Milk: Comparison of an Analytical and an Affective Test *Food Quality and Preference* 14, 515-526
- Havemose M.S., Weisbjerg M.R., Bredie W.L.P. and Nielsen J.H. (2004) The influence of feeding different types of roughage on the oxidative stability of milk *International dairy Journal* 14, 563-570
- Lund-Nielsen T., Skibsted L. and Nielsen J.H. (2005) Comparison of the composition of conventional and organic milk (In manuscript)
- Rochon J.J., Doyle C.J., Greef J.M., Hopkins A., Molle G., Sitzia M., Scholefield D, Smith C.J. (2004) Grazing legumes in Europe: a review of their status, management, benefits, research needs and future prospects. *Grass and Forage Sci.* 59, 197-214.
- Rutter S.M. (2006) Diet preference for grass and legumes in free-ranging domestic sheep and cattle: Current theory and future application. *Applied Animal Behavior Science* 97, 17-35.

# The impact of grazing on sward characteristics and milk yield on a sub-mountain dairy farm

Frelich J., Šlachta M., Čermák B., Vávrová L., Rost M., Sýkorová Z. and Hakrová P.

*University of South Bohemia in České Budějovice, Faculty of Agriculture, Studentská 13, CZ-37005, České Budějovice, Czech Republic*

## Abstract

Grazing by cattle is a traditional grassland management practiced in the sub-mountain area of the Czech Republic. The choice of the most convenient breed of cattle and pasture management is a prerequisite of sustainable multifunctional farming. Although there has been a rising interest in beef breeds in the last two decades, the dairy breeds of Holstein and Czech Pied with good beef and dairy performance have been largely used for grazing in the Less Favoured Areas (LFA) of the Czech Republic. The vegetation characteristics of swards grazed by cows of these two breeds and their milk yields were measured on a model farm in the foothills of the Novohradské Hory Mountains, 600-650 m above sea level. A total vegetation cover of between 85% and 95% of the area was found for pastures grazed at a mean stocking rate of 0.9 livestock units ha<sup>-1</sup>. On average, from 2000-2006 the multiparous Holstein and Czech Pied cows produced an additional 3.5 and 3.2 kg of milk per day, respectively, during the grazing season compared with housing season. The results from the model farm suggest that both a well preserved sward and good milk productivity can be achieved by an appropriate pasture management of Holstein and Czech Pied breeds.

Keywords: grazing, cattle, fibre content, milk yield

## Introduction

Permanent grasslands make up 23% of the agricultural land in the Czech Republic. For the most part they are located in sub-mountain and mountain areas, which are considered as LFA with a lower production capacity than agricultural land at lower altitudes. The traditional management of the permanent grasslands is cattle grazing and the production of forage. However, more than a 50% reduction of cattle numbers in the Czech Republic during last two decades has made the management of permanent grasslands difficult. Although there has been an increased interest in beef breeds, the dairy breeds of Holstein and Czech Pied with good beef and dairy performance have been largely used for grazing in the Czech Republic. In 2006, the total population of dairy cows of 424 000 comprised mostly of Holstein and Czech Pied breeds in nearly equal proportions, while the total population of beef cattle included 140 000 cows (Kvapilík *et al.*, 2006). The choice of the most convenient breed of cattle and pasture management is a prerequisite of ecologically and economically sustainable multifunctional farming. The objective of this study was to survey two aspects of intensive cattle grazing on a sub-mountain dairy farm: (1) the plant species composition and fibre content of swards either grazed or cut for silage and then grazed by cows in 2006, and (2) the milk production of Holstein and Czech Pied breeds of primiparous and multiparous cows during the grazing season compared to the housing season between 2000 and 2006.

## Materials and methods

Surveys of sward vegetation were carried out in 2006 on a farm located in the foothills of the Novohradské Hory Mountains at an altitude of 600-650 m above sea level. The seasonal rotational grazing of Holstein and Czech Pied cattle has been practised on for 30 years, primarily for milk production. The grazing season in 2006 started on the 12<sup>th</sup> May and lasted until the end of October. The herd consisted of 50 Holstein and 62 Czech Pied cows which grazed in 4 cycles on a total area of 132 ha and were milked twice per day. A proportion of the farm was harvested for grass silage in late May and grazing on the pastures prepared for silage was delayed until late June. During the grazing season pasture herbage accounted for 60-80% of the feed ration. Cows were offered an additional grain concentrate with mineral supplements during milking. During the housing season they were offered grass silage, hay and grain concentrates with mineral supplements.

The vegetation of the pastures was examined using standard phytocenological methods based on scanning (Moravec, 1994). Two transects with five fixed stands each at 30 m intervals were used for long term monitoring of two pastures that were managed either by grazing from early May to late October (“grazed”) or cut for silage in late May and then grazed (“cut + grazed”). Scans of 16 m<sup>2</sup> areas were sampled at each stand. The plant species composition and the total vegetation cover in the two pastures were surveyed. Herbage from a 10 m<sup>2</sup> area was collected from the grazed and cut + grazed pastures in July 2006 and September 2006 and analysed for fibre content. The content of acid detergent fibre (ADF) and neutral detergent fibre (NDF) in the dry matter was determined using an *in vitro* method (Van Soest and Wine, 1967). A two-way analysis of variance was used to test for differences in fibre content of the herbage between the two plots and sampling dates.

The milk yields (kg of liquid milk day<sup>-1</sup>) of individual Holstein and Czech Pied cows were recorded once a month from 2000 to 2006. A total of 298 Holstein and 300 Czech Pied cows were recorded for primiparous (1<sup>st</sup> lactation) and multiparous (subsequent lactations) cows during the grazing season. Linear regression analysis was applied in order to evaluate trends in milk production in the grazing and housing seasons (Frelich *et al.*, 2006). Days in milk and a dummy “season” variable were used as explanatory variables. The significance of the best suited model was evaluated by analysis of variance. The significance of the “season” variable was evaluated by the Wald’s test and served as an estimate of the difference in seasonal milk productivity.

## Results and discussion

The vegetation of the pastures consisted mostly of *Lolio-Cynosurelion* suballiance. The potential natural vegetation was identified as *Luzulo albidae – Quercetum petraeae* and *Abieti – Quercetum*. These species are typical of sub-mountain regions of the Czech Republic and are suited to the grazing management of pastures dominated by *Lolio-Cynosurelion* (Frelich *et al.*, 2006). There was an average of 17 plant species recorded in the scans. The species with a cover higher than 5% of the areas surveyed were *Lolium perenne*, *Festuca rubra*, *Agrostis capillaris*, *Dactylis glomerata*, *Phleum pratense*, *Poa pratensis*, *Taraxacum* sect. *Ruderalia*, *Trifolium repens*, *Achillea millefolium* and *Trifolium pratense*. A partial degradation of the pasture was indicated by the occurrence of nitrophyl species of *Rumex obtusifolius*, *Cirsium arvense*, *Persicaria maculata*, *Artemisia vulgaris*, *Chenopodium album* and *Tripleurospermum maritima*.

The herbage composition of a pasture is strongly affected by cultivation and utilization by grazing or cutting. Among other factors the stocking rate of ruminant livestock plays a key role in modifying the botanical composition and structure of a grazed sward. For example, a

low grazing intensity leads to selective defoliation of some areas of pasture and results in the creation of patches where an undesirable succession of species may progress. In contrast, a high stocking rate causes a disruption of herbage cover due to intensive defoliation and trampling by livestock (Sanderson *et al.*, 2004, Pavlů *et al.*, 2006). In the present study the mean stocking on the model farm of 0.9 livestock units (LU) ha<sup>-1</sup> (1 LU = 500 kg of body weight, 1 cow = 550 kg of body weight) resulted in a median total vegetation cover of 85% in May and 95% in July and September for both surveyed pastures. The cover of mosses was less than 1%.

A higher ADF content in the herbage was found on the cut + grazed pasture compared to the grazed pasture in July and September (Table 1). The ADF content of the herbage from both pastures increased towards the end of season. Therefore, the cutting of silage could have resulted in a lower digestibility of the pasture herbage during the subsequent grazing period. The difference between NDF and ADF accounts for a content of fibre digestible by rumen micro-organisms, which play an essential role in metabolism of ruminants (Ball *et al.*, 2002). However, no significant differences in the “utilisable fibre” content of the herbage (NDF - ADF) were found between the grazed and cut + grazed plots (Table 1).

Table 1. The mean content of acid detergent fibre (ADF) and neutral detergent fibre (NDF) in the dry matter of pasture herbage and the difference between NDF and ADF, or “utilisable fibre” content.

Date of sampling	Plot	ADF (%)		NDF (%)		NDF-ADF (%)		N
		Mean	S.D.	Mean	S.D.	Mean	S.D.	
July 2006	Grazed	28.6	1.7	45.4	2.7	16.8	2.4	5
	Cut + grazed	30.0	1.3	46.3	3.1	16.3	2.0	3
September 2006	Grazed	30.1	2.3	46.0	3.6	16.0	5.1	6
	Cut + grazed	32.7	1.0	49.1	2.8	16.4	2.9	3
Date		*		NS		NS		
Plot		*		NS		NS		
Date x Plot		NS		NS		NS		

N> number of 10 m<sup>2</sup> samples; S.D.: Standard deviation; \*: P<0.05; and NS: non significant (P> 0.05).

The average milk production per lactation was 6463 kg cow<sup>-1</sup> for the Holstein cows and 5613 kg cow<sup>-1</sup> for the Czech Pied cows. These yields correspond to 82% and 94% of the average milk production per lactation for the Czech population of these breeds respectively. A positive effect of grazing on individual milk yields was found in both breeds. On average, the Holstein and Czech Pied breeds of primiparous cows produced additional 1.9 and 1 kg milk per day, respectively, and the multiparous cows produced an additional 3.5 and 3.2 kg milk per day, respectively, during the grazing season compared with the housing season (Table 2). Apart from a higher milk yield capacity of the Holstein breed due to its genetic potential, both of the breeds responded similarly to grazing management practised. This indicated a good adaptation of both breeds to the grazing conditions in the sub-mountain area of the Czech Republic.

Table 2. Characterization of the best suited linear regression model for individual milk yields with two explanatory variables (days in milk and “season” variable) and significance of “season” variable regression coefficient.

Breed		R <sup>2</sup>	DF	P (model)	Season coefficient	P (coef.)
Holstein	Primiparous	0.36	678	P<0.001	1.9	P<0.001
	Multiparous	0.56	1631	P<0.001	3.5	P<0.001
Czech Pied	Primiparous	0.39	831	P<0.001	1.0	P<0.05
	Multiparous	0.54	2180	P<0.001	3.2	P<0.001

## Conclusions

Well preserved swards were achieved by grazing or silage cutting and grazing by Holstein and Czech Pied dairy cows at an average stocking rate of 0.9 LU ha<sup>-1</sup>. A higher ADF content was identified in the herbage of cut + grazed swards in comparison with grazed swards and it increased towards the end of season under both managements. The average milk production corresponded well with the national average, which indicated a good efficiency of grazing management on the surveyed farm. The Holstein and Czech Pied cows responded similarly to the pasture management in terms of milk yields.

## Acknowledgements

The work was supported by the Ministry of Education, Youth and Sports, the research project No. MSM 6007665806, and by the NAZV project No. QF 3018 of the Ministry of Agriculture of the Czech Republic.

## References

- Ball D.M., Hoveland C.S. and Lacefield G.D. (2002) Southern Forages. Potash and Phosphate Institute, 322 pp.
- Frelich J., Pecharová E., Klimeš F., Šlachta M., Hakrová P. and Zdražil V. (2006) Landscape management by means of cattle pasturage in the submountain areas of the Czech Republic. *Ekologia-Bratislava*, 25, 116-124.
- Kvapilík J., Pytloun J., Bucek P. and Suchánek B. (2006) Yearbook-Cattle breeding in the Czech Republic (in Czech). ČMSCH, 110 pp.
- Moravec J. (ed.) (1994) Phytocenology. Academia, Prague, 403 pp.
- Pavlu V., Hejcman M., Pavlu L., Gaisler J. and Nežerková P. (2006) Effect of continuous grazing on forage quality, quantity and animal performance. *Agriculture, Ecosystems and Environment*, 113, 349-355.
- Sanderson M.A., Skinner R.H., Barker D.J., Edwards G.R., Tracy B.F. and Wedin D.A. (2004) Plant species diversity and management of temperate forage and grazing land ecosystems. *Crop Science*, 44, 1132-1144.
- Van Soest P.J. and Wine R.H. (1967) Use of detergents in the analysis of fibrous feeds. IV. Contamination of plant cell-wall constituents. *Journal of Association of Analytical Chemists*, 50, 50-55.



## Session 2

# Impact of grassland management systems on environment



# Short-term and cumulative effects of grassland cultivation on nitrogen and carbon cycling in ley-arable rotations

Vertès F.<sup>1</sup>, Hatch D.<sup>2</sup>, Velthof G.<sup>3</sup>, Taube F.<sup>4</sup>, Laurent F.<sup>5</sup>, Loiseau P.<sup>6</sup> and Recous S.<sup>7</sup>

<sup>1</sup>*INRA UMR Sol Agronomie Spatialisation - 4 rue de Stang Vihan, F-29000 Quimper*

<sup>2</sup>*IGER, North Wyke, Okehampton, Devon, EX20 2SB, UK*

<sup>3</sup>*Alterra, PO Box 47, 6700 AA Wageningen, The Netherlands*

<sup>4</sup>*Institute for Crop Science and Plant Breeding, University of Kiel, 24098 Kiel, Germany*

<sup>5</sup>*ARVALIS - Institut du Végétal, F- 91720 Boigneville, France*

<sup>6</sup>*INRA – Agronomie-Ecosystèmes herbagers, avenue du Brézet, F-63100 Clermont-Ferrand*

<sup>7</sup>*INRA, UR1158 Unité d'Agronomie Laon-Reims-Mons - rue Fernand Christ, F-02000 Laon*

## Abstract

Ley-arable rotations, common in dairy systems, have been established for many years and are used to ensure good productivity, facilitate control of weeds and diseases, and limit the decrease in SOM frequently observed under permanent arable cultivation. This paper deals with the short- and long-term effects on SOM of ley-arable rotations with widely different grass:crop ratios to answer the following questions: i) how are the carbon and nitrogen cycles affected by grassland cultivation (or renovation); ii) are the amounts and quality of SOM affected by the grass:crop ratio; iii) can we predict short-term N and C losses in leaching and gaseous emissions; iv) can we predict the SOM dynamics?

Keywords: Nitrogen and carbon, mineralisation, grassland, tillage, ley-arable rotations, soil quality

## Introduction

In Europe, intensive dairy production systems are often based on ley-arable rotations. The development of ley farming (Stapledon, 1935), an approach that is also fundamental to many modern day organic farming systems, was based on the recognition that soil organic matter (SOM) accumulates over time and that soil nitrogen (N) also accumulates in proportion to SOM.

Ley-arable rotations present both benefits and risks:

- they ensure good productivity, facilitate control of weeds and diseases and limit the decrease of SOM frequently observed in permanent arable land (Sebilotte, 1980; Conijn *et al.*, 2002)
- grassland soils fulfil important functions for humans, protecting water and air quality, conserving biodiversity (plants, micro/meso/macro-fauna and flora), and reducing some physical risks (e.g. storing water, preventing soil erosion)
- a characteristic of grasslands is their wide distribution in different soil types and climate. Thus, a large variation in physical, chemical and biological soil characteristics may be expected as a result of the effects of cultivation on native soil conditions
- the consequences of grassland cultivation are also now becoming increasingly important because of their environmental impacts. The assessment of soil N mineralisation has long been a concern for scientists who wished to control both productivity and nutrient losses. At present, the accumulation of soil C is becoming a major interest: faced with rising concentrations of CO<sub>2</sub> in the atmosphere, scientists have proposed that efforts are made to promote C sequestration in soils (considered as

a sink) by converting arable cropping systems to perennial vegetation, grassland or forest.

As pointed out by Janzen (2006), the dilemma is that organic matter is most useful biologically when it decays. Destruction of grassland vegetation results in increased mineralisation that is useful to the following crops, but often leads to losses of the major nutrients. The first General Meeting of the EGF held in Wageningen in 1965 had N in grassland as its main topic, with papers on soil N and ley farming (Van Burg and Arnold, 1966). More recently, two reports of the EGF working group on *Grassland re-sowing and grass-arable rotations* reviewed the advantages and limitations of carrying out reseeded (Conijn *et al.*, 2002; 2003). Agricultural practices were compared between countries and losses were quantified according to practices during the grassland phase (e.g. sward age, management of crop, type of vegetation) and on cultivation interactions with soil characteristics and climatic conditions (e.g. season, cultivation techniques, following crops). To decrease the risk of losses, a better insight into soil processes during the lifetime of the sward and after cultivation of grassland is required.

This paper reviews the effects of grassland renovation on N and C cycles, soil quality, and the risks of N losses (i.e. leaching to ground and surface waters and/or as nitrous oxide emissions). We first shall report on the currently available information on N and C storage and turnover in grassland, according to grassland management, and examine the fluxes following grassland destruction, describing the methods available to measure and quantify them. We then consider the long-term effects on SOM of ley-arable rotations that differ widely in the ratio of grass/grass+crops (G/G+C) and examine the possibility of predicting SOM dynamics in grasslands. To conclude, we shall point to areas where a lack of knowledge requires more research and examine potential management options to develop sustainable ley-arable systems that combine good agricultural performance with reduced risks to the environment.

## **1. Organic matter in grassland soils**

### ***1.1 N and C inputs***

Nitrogen enters the soil via symbiotic fixation, organic and chemical fertilizers, and via animal excretions and senescent plant material. The main outputs of N are from exported crops leaving the field and losses in drained water (as nitrate or dissolved organic N) or to air ( $N_2$ ,  $NO_x$  and  $NH_3$ ). The balance between inputs and outputs determines the net accumulation of N and C in soils as humified, aggregated organic matter (AOM) or fine through to coarse particulate organic matter (POM).

The key processes involved in C cycling in agricultural soils are light interception by leaves, C assimilation via photosynthesis, allocation of assimilates to above- and below-ground plant parts, biomass removal by grazing animals or harvesting, senescence, and death of leaves and roots that are returned to the soil. Large amounts of fresh organic matter are returned to soils during the grassland phase. Carbon inputs to soils come from photosynthesis via exudates, dead leaves and roots, and indirectly via excretions and remains of micro through to macro fauna. The main outputs of C are plant exportation from the field, soil erosion, respiration of  $CO_2$  and gaseous losses (principally  $CH_4$ ) from plants, soil biomass and fauna.

Several factors contribute to N and C dynamics under grassland (Arrouays *et al.*, 2002):

- the level of organic input is high because of the perennial nature of the plants. Whilst there is reasonable agreement concerning the estimates of C inputs derived from wheat and maize crops (e.g. NGuyen, 2003), those from grasslands are quite variable, depending on the method of measurement, the diversity of grassland type and management, and the OM pools considered. If we include dead leaves and roots, rhizodeposition (Warembourg *et al.*, 2003), and animal excretions, OM inputs may vary from 1 to >5 t C ha<sup>-1</sup>yr<sup>-1</sup> (Paustian *et al.*, 1990). Lemaire (1999) considered that up to 40% of above-ground biomass production (i.e. 1 to 3 t C ha<sup>-1</sup> yr<sup>-1</sup>) will return to the soil, in agreement with other findings (Parsons *et al.*, 1991; Scholefield *et al.*, 1991; Loiseau *et al.*, 1995; Kusyakov *et al.*, 2001). In addition, approximately 50-60% of C assimilated by young plants can be transferred below ground (Gill *et al.*, 2002; Rees *et al.*, 2005). In grazed grassland, quantifying inputs from different processes has proved difficult, and the relative importance of exudation and root death under field conditions remains uncertain.
- the main input of OM is from roots (exudates and dead roots), which contribute to C storage because their location in the soil matrix provides good physical protection (Balesdent and Balabane, 1996; Six *et al.*, 2002).
- in the absence of soil tillage, readily decomposable fresh organic matter stimulates the microbial biomass, which improves aggregation and soil structural stability. In turn, the retention of SOM improves C storage (Six *et al.*, 2002).
- root biomass and the amounts of POM derived from root litter usually increase with grassland age over several years until an equilibrium is reached (Whitehead *et al.*, 1990).
- OM inputs from grassland are generally more resistant to degradation than those from annual crops because of their higher content of lignin and aromatic compounds.

The protection provided by the soil matrix results not only in a slower rate of root-litter transformation when compared with tilled soils, but also in a higher proportion of C being stabilised.

The quality of plant tissues has been largely investigated for total N content and C:N ratio according to plant species, grass management (in particular, fertilisation), and plant parts. These factors partly explain the decomposition rate and dynamics (Trinsoutrot *et al.*, 2000; Personeni, 2004). Fewer data have been collected on the biochemical qualities of plant residues that may influence their fate, in particular lignin content combined with N content (Eriksen and Jensen, 2001). White clover (*Trifolium repens*) residues are more readily degradable than ryegrass (*Lolium* spp.) with lower C:N ratios, a larger soluble fraction and less hemicellulose, while lignin and cellulose fractions are similar for the two species (see Table I), although this is not always the case (Eriksen and Jensen, 2001).

Table 1: Mean biochemical composition of plant residues at grassland destruction according to Van Soest (1963). Each value is the mean of 6 sites/treatments for ryegrass and 2 sites for clover in mixed swards (1 standard deviation in parentheses, unpublished data).

<i>Plant</i>	<i>Treatment</i> (kg N ha <sup>-1</sup> )	<i>Lignin</i> (% DM)	<i>Hemicellulose</i> (% DM)	<i>Cellulose</i> (% DM)	<i>Soluble</i> C (% DM)	<i>C:N</i>
Ryegrass	0-400	9.1 (1.4)	32.1 (1.6)	29.3 (4.0)	29.5 (2.8)	22.5 (4.2)
White clover	0-50	9.2	17.0*	24.9	49.0*	14.5*

\* significant ( $P=0.01$ )

Loiseau *et al.* (2005) studied how variation in SOM quality is linked to botanical composition, grassland management, and age of herbage, through the evolution of leaf/stem/root proportions and chemical composition. They classified some parameters of C dynamics for their rates of decomposition (linked to N content) and their humification coefficient according

to microbial and detritic pathways in six main fodder systems. Much of the variation in litter quality was due to botanical composition: mainly the relative abundance of competitive versus conservative species (Personeni, 2004). Grassland management therefore could modify C turnover both through direct, immediate and indirect, long-term (botanical) effects, both of which influence amplification or regulation of net flux dynamics.

### 1.2 OM accumulation

High OM inputs under conditions of low degradability result in the accumulation of N and C, generally starting soon after grassland establishment. The balance is always positive in young grassland, usually declining asymptotically with age (Figure 1) but continuing for up to 100 years (Jenkinson *et al.*, 1994; Arrouays *et al.*, 2002). Annual fluxes of C storage over 20 years varied from +0.1 to +0.5 t C ha<sup>-1</sup>yr<sup>-1</sup> (i.e. apparently less than 10% of inputs) in relation to changes in agricultural practices in fodder crops and grasslands, with lower values for poorly fertilised temporary pastures.

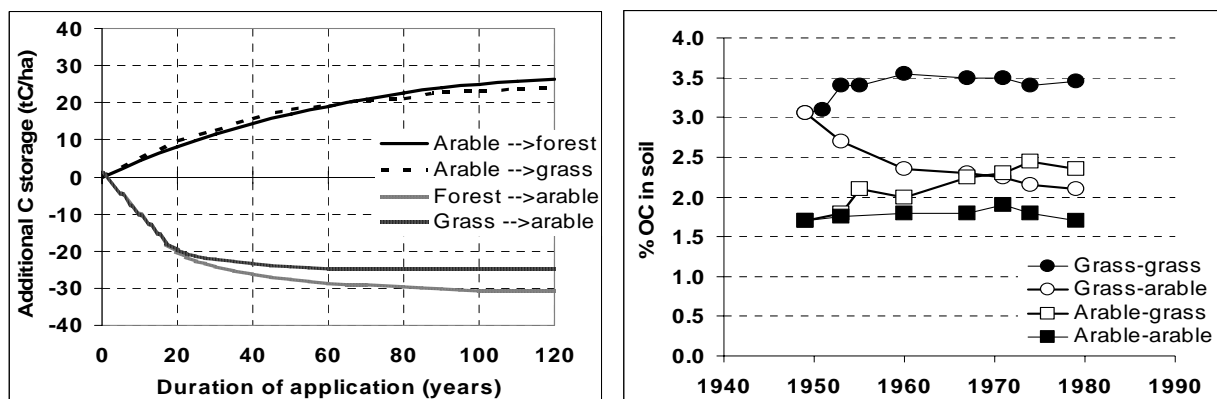

Figure 1. a) Carbon accumulation in soils associated with practices that enhance sequestration (0.5 t C ha<sup>-1</sup> yr<sup>-1</sup> for the first 20 years) or release (1 t C ha<sup>-1</sup> yr<sup>-1</sup>). Based on modal values for France, with confidence interval about 40% (from Arrouays *et al.*, 2002). b) Organic content accumulation in soils from the long-term Rothamsted trial according to changes in land use (from Johnston *et al.*, 1994).

The rate and duration of OM accumulation depend partly on initial N and C contents. Hoogerkamp (1984) (in Velthof and Oenema (2001)) observed that N accumulation in young grassland swards was larger in soils with a low initial N content than with a high N content and higher in a clay soil than in a sandy soil (130 and 70 kg N ha<sup>-1</sup> yr<sup>-1</sup>, respectively). A large range in N accumulation is reported in the literature. Tyson *et al.* (1990) recorded an annual rate of 75 kg N ha<sup>-1</sup> yr<sup>-1</sup>, approximately linear for the first 10 years under pasture on a loamy soil over chalk at Hurley (UK). Similar rates of N accumulation were recorded by Hatch *et al.* (2000b) in a long-term pasture on a silty clay loam over clay at North Wyke (UK). They concluded that only one-third of the 3000 kg N ha<sup>-1</sup> applied as fertilizer over 15 years was retained in the soil, an amount proportional to C accumulation in a 10:1 ratio. Carbon and N accumulation occur mainly in the upper 10 cm of soils, where up to 80% of below-ground plant biomass develops. As measured by Davies *et al.* (2001), 84-89% of organic N was found in the upper 10 cm of soil under 8-year-old grass/clover and pure grass swards. N and C generally are closely linked, but their accumulation dynamics may differ. In a crop-rotation experiment, the organic C content of soil increased 10% over six years in crop rotations with 2-3 years of grassland, compared with rotations without grassland (Søgaard, 1988), but the soil organic N content did not increase. This discrepancy was observed in several studies and should be taken into account in models that simulate mineralisation.

The time required to reach an equilibrium SOM content varies from a few years to more than one century (Johnston *et al.*, 1994) and depends on the initial SOM content and other soil characteristics (e.g. texture), though comprehensive data are lacking. Models usually consider constant rates of input and degradation to determine maximum SOM content, but recent research (Fontaine *et al.*, 2003) indicates that soil biomass may adapt to a lack of nutrients by decomposing older, more recalcitrant SOM. These recent studies try to understand the dynamic relationship between SOM content, fresh SOM inputs, and decomposer activity by taking into account amounts, quality, and spatial distribution in soils of the labile through to recalcitrant OM, as well as its sequence in the activity of decomposing soil microflora (Recous, 2005). Novel  $^{13}\text{C}$  labelling techniques (e.g. Loiseau and Soussana, 1999a, b ;Bol *et al.*, 2005) have improved the description of the accumulation of new OM inputs derived from plant residues and characterized their residence time, which increases with decreasing particle size.

Several sources of variability in the magnitude and duration of net positive accumulation may be considered:

- all processes that determine OM inputs are subject to variability (Lemaire, 1999). For example, photosynthesis efficiency and distribution of C between leaves and roots vary between season and according to the N status of soil.
- a large natural spatial variability is observed for soil N content and, to a lesser extent, for soil C content (Walter *et al.*, 2003). To cope with this crucial issue in SOM studies, most authors consider that accurate estimates of changes in N and C soil contents can be obtained only with long-term field experiments (Jenkinson and Rayner, 1977; Paustian *et al.*, 1995; Katterer and Andren, 1999), or by using isotope tracing (Andriulo *et al.*, 1999a).
- changes in plant rhizodeposition and senescence (above- and below-ground) over time are quite difficult to measure, especially with grazing animals present and not yet well simulated by models.
- some variability is due to difficulties in measuring soil organic pools (e.g. soil depth, bulk density, sieve size).

### ***1.3. N and C mineralisation-immobilisation turnover (MIT)***

Soil microbes are the main facilitators of N and C cycling in soils as they are involved in the processes of humification, immobilisation, and mineralisation. Their activity is particularly important and variable in grassland (Booth *et al.*, 2005). Using  $^{15}\text{N}$  tracing, Mary and Recous (1994) found net mineralisation, gross immobilisation and mineralisation in the ratio 1:2:3 for arable systems; in grasslands it is about 1:6:7 (Tlustos *et al.*, 1998; Hatch *et al.*, 2002; Booth *et al.*, 2005). Accoe *et al.* (2004) investigated the relationship between grassland age, SOM characteristics, and gross fluxes. They showed that gross N mineralisation, nitrification, and gross N immobilization rates tended to increase with increasing age of swards and were positively correlated to total N and C, though not fully explained by this factor due to changes in soil fractions. The relationship between long-term net and gross N mineralisation rates could be fitted to a logarithmic equation, which suggests that the ratio of gross N immobilization:mineralisation tended to increase with increasing SOM contents. Microbial demand for N tended to increase with increasing SOM content in grassland soils, indicating that potential N retention in soils through microbial N immobilization tends to be limited by C availability.

Measuring and predicting mineralisation in grassland is thus difficult, and much work has been done to answer these questions. There is a wide variety of methods for estimating net mineralisation of N and C in grasslands, fields, or the laboratory, without any agreement on a standard method. One group of methods measures plant uptake from unfertilized plots as an

indicator of soil N supply, while another is based on incubation studies under controlled conditions in the laboratory or under field conditions. Both types of measurement are used to calibrate models that are more or less mechanistic (e.g. Thornley and Verberne, 1989; Scholefield *et al.*, 1991). The large differences observed between these methods are due mainly to differences in OM content, which explains a large part of the variability among sites. Mineralisation rates are also influenced by soil pH, drainage status and climatic conditions. However, an important part of the variability among incubation results is linked to the choice of soil sampling depth. For example, a strong decrease in N mineralisation rates with increasing depth (i.e. three-fold difference between 0-10 and 10-20 cm) has been observed by several authors (Velthof and Oenema, 2001).

#### ***1.4 Plant residues after grassland destruction***

Grassland cultivation induces the death of most of the living biomass that forms the grass sward, which then becomes an OM input to the soil. Amounts of plant biomass and their N and C content have been measured by several authors (Table 2).

Table 2. Quantification of plant residue biomass and composition after grassland destruction

Treatment	Grassland age (yrs)	DM plant residues (t ha <sup>-1</sup> )	N in plant residues (kg ha <sup>-1</sup> )	C:N ratio	Reference
Grass/clover	4	13.0 <sup>a</sup>	330	16.5 <sup>c</sup>	<i>(Djurhuus and Olsen, 1997)</i>
Grass/clover	3	10.8 <sup>a</sup>	300	15.2 <sup>c</sup>	
Grass/clover	3	7.5 <sup>a</sup>	177	17.8 <sup>c</sup>	
Ryegrass	5-7	10.6 <sup>a</sup>	180	21.2	<i>(Laurent et al., 2004)</i>
Grass/clover	5-7	6.3 <sup>a</sup>	131	18.0	
Ryegrass	8	20.3 <sup>b</sup>	312	29.3 <sup>c</sup>	<i>(Davies et al., 2001)</i>
Grass/clover	8	18.8 <sup>b</sup>	260	32.5 <sup>c</sup>	
Ryegrass	3	12.1	298	14.5	<i>(Eriksen and Jensen, 2001)</i>
Grass/clover	3	9.4	174	20.0	
Ryegrass	1	7.1 <sup>b</sup>	120	26.0 <sup>c</sup>	<i>(Whitehead et al., 1990)</i>
Ryegrass	3	8.0-8.5 <sup>b</sup>	140-190	19.0-22.0 <sup>c</sup>	
Ryegrass	8	14.5 <sup>b</sup>	340	17.9 <sup>c</sup>	
Ryegrass	15	15.0 <sup>b</sup>	360	17.5 <sup>c</sup>	

<sup>a</sup> leaves + stubbles + roots, extracted by sieving and washing soil with water

<sup>b</sup> plant tops, living and dead roots, and part of the macro-organic matter pool (soil dispersion with hexametaphosphate)

<sup>c</sup> based on the hypothesis that %C = 0.42 x DM

#### ***Conclusions***

Grasslands are characterized by large OM pools and fluxes, with a large spatial and temporal variability in their amounts and qualities depending on the period of the year, the age of grassland, and the type of management. The separate effects of these factors cannot, at present, be quantified because of a lack of suitable experimental data combining them.

In most cases, N and C accumulation is approximately linear in young grassland soils. The process of OM accumulation is governed by the amounts and chemical quality of inputs, which will influence their fate during interactions with soil and especially the microbial biomass characteristics. This fresh OM pool, specific to grasslands, is a key factor in understanding and modelling OM fluxes during and after sward destruction. The age of grassland has only a weak effect on yearly inputs, but affects macro-organic matter accumulation by humification and detritic pathways. The destruction of grassland will supply the soil with large amounts of plant residues with a relatively low C:N ratio and recently



accumulated and rather labile sources of POM. As a result, large net mineralisation of N and C can then be expected.

## 2. N and C mineralisation after destruction

When a grassland sward is cultivated, the large gross mineralisation is no longer balanced by high immobilisation, at least until the following crop develops. High N and C net mineralization occurs due to large inputs of easily degradable dead organic matter (C:N ratio between 15 and 25) and exposure of the SOM to microbial decomposition, increased aeration, and disruption of soil aggregates (Six *et al.*, 2002).

### 2.1 Amounts

Direct measurements of CO<sub>2</sub> flux have shown that cultivation of grassland was followed by a total emission of 2.6 t C ha<sup>-1</sup> during the first 3 months after cultivation, compared with only 1.4 t ha<sup>-1</sup> emitted from untilled soil (Eriksen and Jensen, 2001). Measurements can be obtained by dynamic chamber methods (Reicosky *et al.*, 1997), but large temporal and spatial variation in flux rates suggest that integration over time requires continuous measurements. A large CO<sub>2</sub> flux was observed during the first hours following tillage, coming from air previously present in soil pores (Reicosky *et al.*, 1997). Loiseau (unpublished data) trapped CO<sub>2</sub> fluxes with soda during one year under bare soil following 20 years of crops, permanent grass, and ley-arable rotations. They observed a lag period of about 50 days, followed by a large increase in CO<sub>2</sub> fluxes up to 15 kg C ha<sup>-1</sup> d<sup>-1</sup> after grassland compared with 7 kg C ha<sup>-1</sup> d<sup>-1</sup> after crops, corresponding to the decomposition of labile fresh organic matter. Total respiration under bare soil during the first year was 1.1, 3.2 and 3.8 t C ha<sup>-1</sup> after crops, ley-arable rotations, and permanent grass, respectively, and were well correlated with soil microbial biomass (Alvarez *et al.*, 1998). Carbon mineralisation is more often measured in incubated soils, which allows estimation of the proportion of fresh plant residues in total C mineralised. For example, Vertès *et al.* (2001) measured C mineralisation which varied from 400-500 mg CO<sub>2</sub>-C kg<sup>-1</sup> dry soil in unamended 'control' soil and from 900-1100 mg CO<sub>2</sub>-C kg<sup>-1</sup> dry soil in the same soil that had received fresh plant residues in the same proportion as in a ploughed grassland. These high values for short-term losses demonstrate that a large part of recently accumulated OM remains highly mineralisable.

Nitrogen mineralisation is commonly measured by several methods using *in situ* or incubated soils (Hatch *et al.*, 2000a). Results in the literature show a wide range of total N mineralisation rates in the first year after ploughing out temporary grasslands, ranging from 100-500 kg N ha<sup>-1</sup> (Johnston *et al.*, 1994; Whitehead *et al.*, 1990; Loiseau *et al.*, 1994 ; Van Dijk *et al.*, 1996 ; Djurhuus and Olsen, 1997; Aarts *et al.*, 2001; Shepherd *et al.*, 2001; Vertès *et al.*, 2001). These data generally include both N mineralisation from SOM and the biomass added from ploughed swards. The wide range is due to differences in experimental conditions (soil type, soil OM content, N management, sward age, crop type and management) and in the method of estimating N mineralisation (N balance, models, N uptake, and *in-situ* or laboratory incubations).

The simplest and more frequently used indicator of soil N supply after grassland destruction is measurement of N uptake by the following crop. In fields of newly sown unfertilized ryegrass established after 20 years of extensive permanent grassland (15 sites in the UK) or 5-12 years of permanent intensively managed ryegrass (7 experimental sites), Hopkins *et al.* (1990) found large variability between sites (55-150 kg N ha<sup>-1</sup> yr<sup>-1</sup>: mean of years 1-3 after grass destruction) and could find no strong relationship between N uptake and either OM or clay content of soils. Similar variability was observed in a network of 45 unfertilized maize fields

in Brittany, France, with 60% of N uptake values between 200-300 kg N (maximum = 520 kg N ha<sup>-1</sup>) and no strong relationship between N uptake and OM content or grassland age. Nevertheless, Antil *et al.* (2001) showed that the percentage of total organic N released annually varied from 2-10% of the total organic N content in soil, depending on the clay content that protected OM from microbial decomposition. When considered collectively, much of the available experimental data may help to provide a better understanding of N and C mineralisation factors and their interactions.

## 2.2 Short-term mineralisation kinetics

Knowledge of mineralisation kinetics is required to attempt to synchronise peak N uptake by the following crops with N mineralization so as to optimize N-use efficiency and minimize nitrate leaching. The kinetics of N and C mineralisation are discussed below and estimates of the contribution of plant residues and other pools to mineralisation, followed by an examination of the duration of the 'grassland-ploughing effect' and how factors that influence it can be assessed.

The potential for N mineralisation is often measured in soils during short-term incubation as a way to compare situations rather than to obtain absolute values. Few studies describing mineralisation kinetics are available in the literature. Laurent *et al.* (2004) estimated *in situ* mineralisation rates with the LIXIM model based on successive soil mineral N profiles from a large variety of treatments (grassland types, locations, cut:grazed ratio, fertilisation rates, season of destruction). In all cases, N mineralisation kinetics consisted of a first phase with rapid mineralization over a period of 160-230 standardized days (at 15°C and soil at 90% water capacity) followed by a second phase with a mineralization rate ( $V_{p2}$ ) 2-7 times smaller

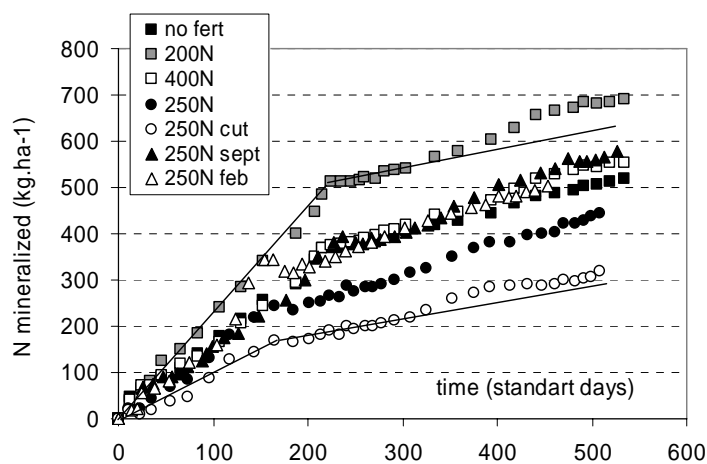

than in phase 1 ( $V_{p1}$ ) and similar to the basal mineralization rate of SOM (Figure 2). Incubation measurements of the same soils, with and without plant residues, showed that C mineralisation was high during the first weeks but almost ceased after 4 months, whereas N mineralisation was fairly constant during a first phase of 4-6 months in most treatments, then was lower during a second phase, as observed by Johnston *et al.* (1994) and Djurhuus and Olsen (1997).

Figure 2. Nitrogen mineralization kinetics in bare soils after ryegrass destruction calculated from *in situ* soil nitrogen and water profiles with the LIXIM model. (from Laurent *et al.*, 2004 ; 6 grazed + 1 cut grasslands, open and close symbols refer to 3 trials)

The main interpretations of these findings are:

- the high mineralisation rates during the first months following grassland destruction could be explained partly by the rapid decomposition of plant residues. However, N and C mineralisation from plant residues assessed in a parallel experiment was about 20 and 25-30% of total N and C mineralisation, respectively (Vertès *et al.*, 2001).
- the N and C mineralisation rates of grassland plant residues mineralised were 20% of N and 50% of C inputs, respectively, which are rather low values (Trinsoutrot *et al.*, 2000).

- net soil N mineralisation was always positive even in unfertilized grass swards, due to the low C:N ratio of plant residues in grasslands, which differ from the residues of most other crops.

In our experiments, N mineralisation in the laboratory appeared to be a good indicator of *in situ* N mineralisation, with a linear relationship explaining 80% of the variability (unpublished results). This is not always the case (Hatch *et al.*, 2000a), for three reasons: i) continuous mineralisation and immobilisation processes involved *in situ* cannot be reproduced in incubated soils (Mary and Recous, 1994), and soil layers display a high gradient in mineralisation activity that does not correspond to sieved soil in incubated jars (Hoogerkamp, 1973, in Velthof and Oenema, 2001); ii) the high temperature and water contents usually used to optimize mineralisation processes in incubated soils may induce the development of soil microorganisms that differ from those adapted to the *in situ* climatic conditions. Moreover, a succession of dry and wet conditions *in situ* can induce a flush that may not be observed under constant controlled conditions; iii) the parameters used to model the effect of temperature and soil water content on mineralisation (Rodrigo *et al.*, 1997 ; Mary *et al.*, 1999) can still be questioned.

No simple indicator can predict C and N mineralisation. Total C or N in soils, microbial biomass, C and N inputs as plant residues or their C:N ratio were not well correlated to C and N mineralisation *in situ* or in the laboratory. Thus C and N mineralisation of macro-organic matter accumulated during the grassland phase appears more important than that of plant residues, as previously shown (Whitehead *et al.*, 1990; Loiseau *et al.*, 1994; Assman *et al.*, 2002) or modelled (Bhogal *et al.*, 2001; Katterer and Andren, 2001).

### 2.3 Duration of the 'grassland -ploughing effect'

The previous results, concerning ley-arable rotations, show that most of the increased mineralisation due to grassland destruction is achieved during the first few months following ploughing. There is a good agreement among authors for similar situations, as shown in Figure 3 (Davies *et al.*, 2001; Velthof and Oenema, 2001; Laurent *et al.*, 2004; Young *et al.*, 1986). Using the response of the following crop to N as an indicator of soil N supply in the years following grass destruction, other authors show a similar rapid decrease with time of N availability to crops (Eriksen, 2001; Johnston *et al.*, 1994; Nevens and Reheul, 2002).

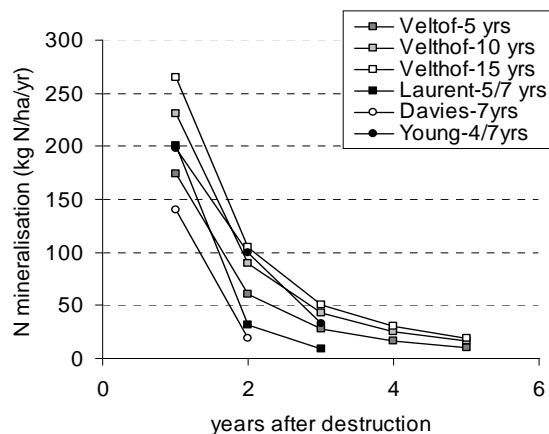

Figure 3. Duration of the effect of grassland cultivation on nitrogen mineralisation in several studies from northwest Europe.

Schils *et al.* (2006) and Shepherd *et al.* (2001) found no effect of cut grassland cultivation on nitrate leaching in the second winter after reseeding a new sward. Nevertheless, Loiseau *et al.* (1994) and Djurhuus and Olsen (1997) observed a slow decrease in N leaching for 3 years after destruction of a 3 to 4 year-old grassland (in long-term trials). In any case, results may vary with the amounts of nitrate leached. Lloyd (1992) recorded a strong decline in leaching over time after destruction of a highly fertilized grass, while N leaching was lower and similar during the first two winters after the destruction of moderately fertilized grassland.

This confirms that the delayed effect of grassland age at destruction is due more to the macro-organic matter accumulated than to fresh plant residues (for which the major part of decomposition is achieved in less than 1 year). These observations raise questions about the residence time of 'grassland-linked' organic matter. Several authors (Boiffin and Fleury, 1974; Loiseau *et al.*, 2005; Patra *et al.*, 1999) concluded that macro-organic matter, mainly partly decomposed, dead fibrous material, constituted the main source of N and C mineralisation compared with fresh plant litter. Considering even longer time scales, Springhob *et al.* (2003) concluded that historical grasslands may still have an impact on current N and C turnover, even decades after conversion to arable. More information about this effect is needed to determine the contribution made to gross and net mineralisation fluxes within and following grassland, for inclusion in predictive models.

### **3. N and C losses after ploughing**

Enhanced N mineralization increases the risk of leached and gaseous N losses through denitrification, when the amount of mineralized N exceeds the N uptake of the following crop. A N leaching risk results from a combination of available nitrate in soil at field capacity and the absence of an alternative sink for nitrate (e.g. plant or microbial immobilisation). Usually these conditions occur in late autumn and winter.

#### **3.1 Nitrate Leaching**

Nitrogen leaching losses have been quantified in several studies (e.g. Loiseau *et al.*, 1994; Djurhuus and Olsen, 1997; Webster *et al.*, 1999; Shepherd *et al.*, 2001; Schils *et al.*, 2006) and range from less than 60 kg N ha<sup>-1</sup> yr<sup>-1</sup> after ploughing out 1 year old leys to 250 kg N ha<sup>-1</sup> yr<sup>-1</sup> after ploughing out 6 year old leys. Factors such as management, soil type, crop type, and ploughing time differed among the studies and may have strongly affected N leaching. The effects of a single factor, however, may vary with site: Lloyd (1992) found a large effect of the previous N status of grass on nitrate leaching, while Laurent *et al.* (2004) found similar losses in highly fertilized (400 kg N ha<sup>-1</sup> yr<sup>-1</sup>) or unfertilized grazed ryegrass. The risk of N losses increases with increasing age of the sward, especially when short-term and medium-term grassland are compared (1 year < 3-4 yrs < 7-10 yrs). For an organic farm in Denmark, Eriksen *et al.* (2004) showed that ploughing a 2 year old grass/clover ley led to moderate N leaching risks (about 40 kg N ha<sup>-1</sup> yr<sup>-1</sup>) after barley, whereas Johnston *et al.* (1994) calculated more than 100 and 250 kg N ha<sup>-1</sup> yr<sup>-1</sup> after 1 year old and 6 year old grasslands, respectively, were cultivated. In a study of leaching losses from organic farms in England and Wales (Stopes *et al.*, 2002), nitrate losses of 45 kg ha<sup>-1</sup> N were measured during the organic ley phase, including the winter of ploughing out. Spring incorporation prior to spring sowing, where possible, has been shown to minimise leaching loss (Watson *et al.*, 1993), which could be related to increased immobilisation in soil biomass.

Leaving the soil fallow after ploughing grassland resulted in high leaching losses (100-300 kg N ha<sup>-1</sup> yr<sup>-1</sup>) (Loiseau *et al.*, 1994; Adams and Jan, 1999; Davies *et al.*, 2001; Laurent *et al.*, 2004). Lloyd (1992) showed residual effects of grassland ploughing on leaching losses during the second winter, which probably can be attributed to bare soils during winter. Sowing a cover crop during winter could decrease N leaching by up to 60%. Lloyd (1992) and Francis (1995) also indicated that ploughing grassland and converting it to arable land in spring instead of the preceding autumn, decreased N leaching losses by 10-50 kg N ha<sup>-1</sup> yr<sup>-1</sup>. Shepherd *et al.* (2001) showed that the effect of spring ploughing for reseeded was relatively short-term (in contrast to repeated annual cultivations in arable rotations) and did not cause increased leaching the following autumn, whereas autumn ploughing and reseeded leached 60-350 kg N ha<sup>-1</sup> yr<sup>-1</sup>. However in both swards, losses the next winter (when swards had been

established for at least 1 year) were no different from undisturbed swards. The effect on nitrate leaching of postponing grassland cultivation from early to late autumn or spring in combination with spring or winter cereals was also studied by Djurhuus and Olsen (1997), who found the least leaching when ploughing was postponed until spring, and by Besnard *et al.* (this volume) who found higher losses after autumn ploughing (winter wheat > rape) than after spring ploughing in grass/maize rotations.

**Cumulated leaching**  
(3 years, kg N ha<sup>-1</sup>)

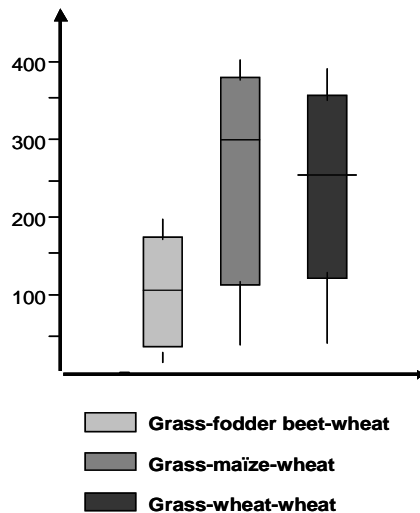

Morvan *et al.* (2000) combined simulated and experimental plant and soil data to assess and compare N leaching risks in 3 typical ley-arable rotations (Figure 4). Lower and less variable risks were associated with late-winter destruction of grassland followed by fodder beet, which may take up about 400 kg N ha<sup>-1</sup> yr<sup>-1</sup> compared with less than 200 for maize. Risk reduction was particularly high on shallow soils, the variability in simulation results being explained by drainage (a function of soil depth and rainfall conditions). Late harvest of maize and winter wheat-sowing limit the ability of any catch crop to use the mineral N in soil, which explains the high loss risks from fodder systems in Brittany.

Figure 4. Effect of grassland destruction according to following crop rotations on leaching losses: result of simulation for 3 ley-arable rotations (from Morvan *et al.*, 2000)

The impact on nitrate leaching of methods of ploughing or otherwise switching from grass to arable crops was tested in some field trials at Coates Farm (UK) by Leach *et al.*, (2002). An unploughed ley leached 5 kg N ha<sup>-1</sup> yr<sup>-1</sup>, winter wheat direct-drilled into the sprayed-off ley leached 35 kg N ha<sup>-1</sup> yr<sup>-1</sup>, and conventionally sown winter-wheat (ploughed, cultivated, sown) leached 70 kg N ha<sup>-1</sup> yr<sup>-1</sup>. Thus, the environmental impacts of ploughing out grass can be alleviated by good management practice.

Most applied research has tried to find indicators of risk. We saw previously that no simple indicator could predict N mineralization and N leaching risks in all situations, nevertheless a more sophisticated indicator was tested with some success. Stockdale *et al.* (2002) found a strong correlation between leaching losses and the N saturation index (i.e. the nitrification:N immobilization ratio) Soils with an index >1 became increasingly 'leaky'. This index could be used as one measure of sustainability to assess the recovery of soils taken out of agricultural production. Decisions on the timing of cultivation also have other environmental implications besides N leaching, including effects on gaseous emissions, C sequestration, and soil erosion.

### 3.2 Gaseous losses

There is relatively little information available on gaseous losses related to grassland destruction. Since both N and C fluxes are important, denitrification may be expected under anaerobic soil conditions. Results from Davies *et al.* (2001) in the UK showed that ploughing of grassland increased N losses via leaching, N<sub>2</sub>O emission, and denitrification when the soil was left fallow. Ploughing, followed by reseeding, considerably decreased N losses, especially from denitrification. Thus, N leaching losses were much higher than those of N<sub>2</sub>O emission and denitrification. Drury *et al.* (2004) demonstrated that both the size distribution of natural soil aggregates and soil grinding can have substantial impacts on CO<sub>2</sub> and N<sub>2</sub>O

production through denitrification. This suggests that grassland tillage may increase denitrification by modifying aggregate size and soil structure. In a study in the UK, differences in methane and N<sub>2</sub>O emissions from ley and arable phases of the rotation were found to be less marked in organic systems than in conventional systems (Vinten *et al.*, 2002).

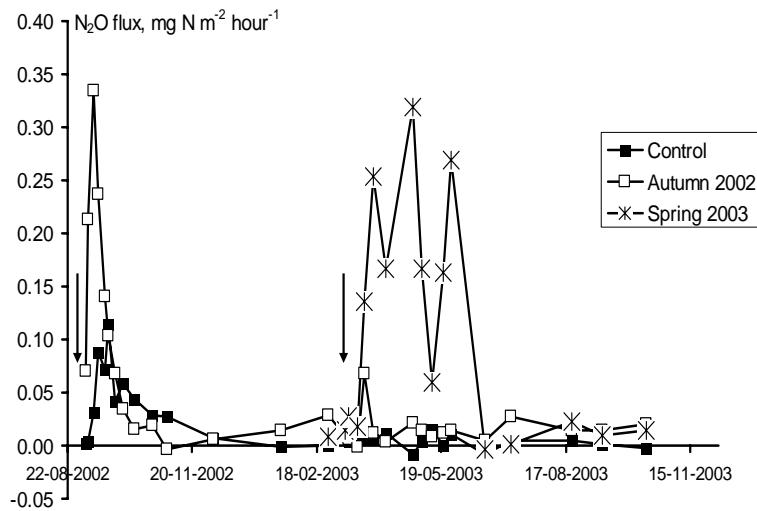

Velthof *et al.* (in prep.) showed that N<sub>2</sub>O emission was high after both autumn and spring grassland destruction (Figure 5), but few differences were observed linked to the intensity of soil cultivation. More generally, N<sub>2</sub>O emission in the Netherlands shows high emissions after ploughing grasslands (Velthof *et al.*, 2000 ; Vellinga *et al.*, 2004), especially during wet and relatively warm periods in summer, more importantly on clay soils vs. sandy soils (about 10 vs. 5 kg N<sub>2</sub>O-N ha<sup>-1</sup> yr<sup>-1</sup>).

Figure 5. Nitrous oxide emission after autumn or spring grassland destruction.

The high concentration of available C in grasslands, especially in the topsoil, causes a difference between grassland and arable land in the potential for denitrification (Table 3), which increases the risk of denitrification losses and nitrous oxide emission. Moreover, in rotations of grassland and arable land, a temporal variation in denitrification potential may be expected, but this has not been shown experimentally.

Table 3. Potential denitrification rates (mg N per kg dry soil per day) in grassland and maize fields on different soils in the Netherlands (from Munch and Velthof, 2007).

Soil layers	Grassland				Maize land	
	Peat (n=3)	Clay (n=3)	Loam (n=2)	Sand (n=3)	Loam (n=2)	Sand (n=3)
0 - 20 cm	267	151	65	26	20	11
20 - 40 cm	317	125	30	4	9	4
40 - 60 cm	116	5	1	0.1	1	0.1
60 - 80 cm	61	0.9	0.3	0.5	0.3	0
80 - 100 cm	39	0.6	0.2	0.2	0.1	0

<sup>1</sup>denitrification under anoxic conditions at 20 °C with excess of NO<sub>3</sub><sup>-</sup>

With regard to ammonia, it is well known that it can be formed during decomposition of crop residues. Larson *et al.* (1998) showed that ammonia losses from a herbage mulch of grass rich in N were substantial (i.e. 39% of the N in applied grass). This also suggests that ammonia may be lost after grassland cultivation, but no results have been found in the literature.

### **Carbon losses**

Carbon losses are mainly in the form of CO<sub>2</sub> from respiration by the soil microbial biomass decomposing large amounts of available fresh organic matter after sward destruction. Few studies have quantified dissolved organic C losses after ploughing out grassland (e.g. Kalbitz *et al.*, 2000). Chantigny (2003) reported an increase in water-extractable organic carbon from 1-19 kg C ha<sup>-1</sup> yr<sup>-1</sup>, depending upon ploughing depth. In lysimeters, Loiseau (unpublished data) measured organic C losses of about 2 kg ha<sup>-1</sup> yr<sup>-1</sup> under bare soil after ploughing. Bhogal *et al.* (2000) showed that significant leaching of organic N may occur after ploughing of grassland, and that soluble organic C is also leached to deeper layers. Soluble organic C is a possible energy source for denitrifying bacteria, and positive correlations have been found between potential denitrification and soluble organic C. The denitrification potential in soil layers below the rooting zone is generally low, thus leaching of organic C may increase the denitrification potential of these layers. If these soil layers become anaerobic (e.g. because of a rise in groundwater), denitrification occurs and less nitrate leaches to the groundwater.

### **4. Soil quality and long-term SOM dynamics in ley-arable rotations**

The concluding part of this paper considers the cumulative effects of long-term ley-arable rotations on soil quality and SOM dynamics. Physical properties, such as rooting capacity, water holding capacity, bearing capacity, and susceptibility to soil compaction are linked to SOM characteristics. The effects of grassland cultivation on these physical components are variable, usually difficult to quantify, and vary with soil type. Schils *et al.*, in Conijn *et al.*, (2002) showed that the renovation of permanent grassland has positive effects on the soil quality of sandy and clay soils, but a negative effect on peat soils. The main causes of grassland degradation, such as soil compaction and infestation by annual weeds or resistant species, often result from treading or scorching damage. A better understanding of the capacity of soil to resist compaction or to recover previous porosity and associated processes would, therefore, help to prevent soil and grassland degradation. One of the key factors influencing changes in soil physical properties is biological activity: effects of rotations on abundance and structure of earthworm populations was shown by Lamandé *et al.* (2003) comparing arable (maize), ley-arable (3 years grass – 1 year maize), and permanent grass fields. A significant difference in earthworms populations resulted in higher effective soil porosity and water circulation in the ley-arable rotation, but the compaction induced in the 7-10 cm layer by repeated cattle treading in permanent pasture was not reversed by earthworm activity. Large differences in the functional diversity of microbial communities between soils of grassland and arable crops has been observed (Booth *et al.*, 2005; Hatch *et al.*, 2000), (2002)), with a decrease in microbial diversity after grassland cultivation. Moreover, some indirect positive effects of grassland cultivation on following crops, such as better resistance to fungal diseases (Eriksen, 2001), may be linked partly to soil structural modifications.

After nearly 30 years of continuous experiment, the accumulated effect of 6 maize-grass rotations (presenting a G/G+C ratio varying from 0-1) on SOM dynamics was recently compared and modelled by Vertès and Mary (2007). The size of N and C stocks decreased only slightly under permanent grass, while a larger decrease (30%) was observed under continuous maize. The C/G+C ratio (Vertès *et al.*, 2005) was well correlated with SOM decrease (Figure 6). Nevertheless, the ability of this ratio to predict the evolution of SOM has to be tested in other long-term trials.

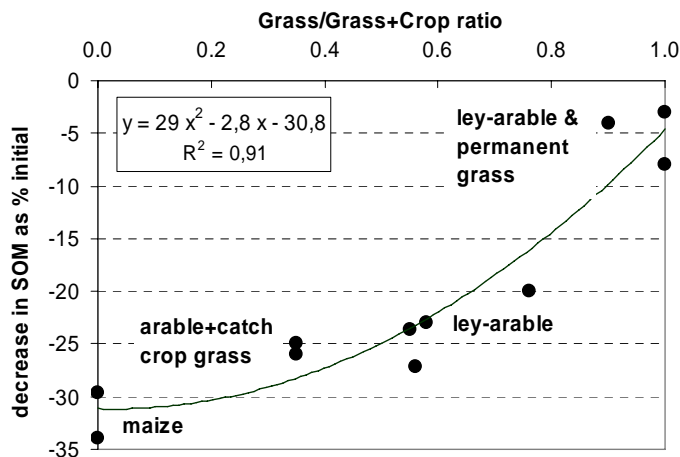
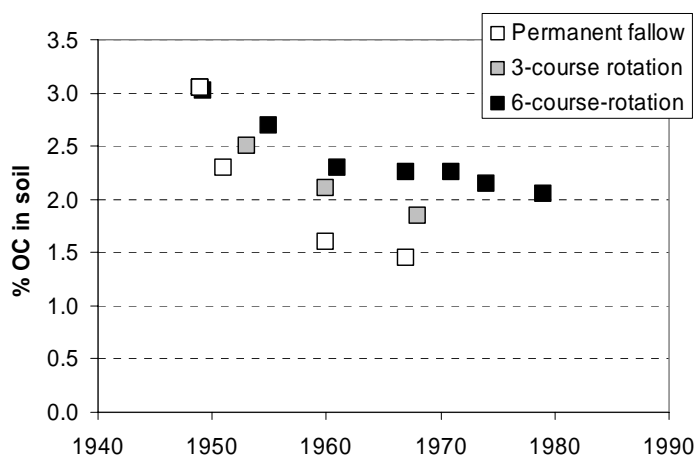

Figure 6. Relationship between SOM decrease and the proportion of grass in ley-arable rotations in a long-term trial (from Vertès *et al.*, 2005).

The environmental performance of ley-arable rotations is now more often considered at the farm level to optimise production and limit the risk of N and C losses. System analyses are needed to evaluate the entire system of grass-arable rotations from both the environmental and agricultural viewpoint. Relatively high losses in the arable phase may be compensated by low losses in the grassland phase. To perform these system analyses, data from permanent



grassland, permanent arable land, and grass-arable rotations are required. Figure 7 illustrates that 6-course rotations (usually practised in Danish systems) preserve soil organic C better than shorter rotations. Nevertheless, the introduction of even short-term grassland in arable rotations has improved agronomic performance of organic and conventional crop farms in northern Europe (Conijn *et al.*, 2003).

Figure 7. Effect of three farm systems (rotations) on soil carbon content (Johnston, 1986).

Tools developed to aid decision making at several scales are increasingly needed. For example, comprehensive models of N and C fluxes at the field scale could improve N use efficiency, decrease the risk of N and C losses and help determine the ability of agricultural soils to store C. The need and interest in gathering long-term experimental data to model N and C fluxes was well established by Smith *et al.* (1997), who compared several models (e.g. CENTURY, SOILN, DAISY). Ma and Shaffer (2001) and McGechan and Wu (2001) reviewed models that consider a few key processes (e.g. AMG for long-term SOC evolution (Andriulo *et al.*, 1999b), DNDC for gaseous emissions ; Li *et al.*, 2000) or several processes (Kelly *et al.*, 1997; Smith *et al.*, 1997), but few have been applied for ley-arable rotations (Bhogal *et al.*, 2001). Additionally, stochastic models (e.g. NGAUGE) have been developed to help decision-making at the farm scale (Brown *et al.*, 2005).



## Conclusions

This synthesis has discussed our current knowledge about N and C cycles in ley-arable rotations. Managing N fluxes (e.g. by maximising N-use efficiency and minimising N losses) requires understanding the underlying processes. Likewise, understanding C fluxes can help improve N management, increase C sequestration in soils, and limit greenhouse gas emissions. Two main approaches have been adopted by researchers, one trying to identify and quantify processes determining N and C cycles in agro-systems, the other based on researching relationships in the available data. Few authors have tried to evaluate their results by gathering data from all available experiments, though an increasing interest in this approach has been shown for modelling and by international working groups (e.g. EGF WG on ‘grassland renovation’, Conijn *et al.*, 2002; 2003).

The main knowledge gaps remaining include:

- Theoretical models are currently unable to explain fully the integration of ‘new’ OM in the SOM pool and the decay of the ‘old’ OM. The factors associated with this are important, not only when OM accumulates, but also when changes occur, e.g. following cultivation. Theoretical compartments are needed to describe measurable SOM fractions. Although significant results have been obtained from SOM fractionation, there is no general agreement on methodology. Finally, most SOM models are additive, and little is known about interactions between SOM compartments under field conditions
- Changes in SOM quality are suggested by the higher proportion of N and C in the coarser SOM fractions under grass-based rotations. These results have allowed the prediction that N and C mineralization rates should be more than proportional to total N and C content of soil, but this hypothesis must be better tested using natural isotope <sup>13</sup>C-tracing experiments
- Root turnover in grasslands in terms of both rooting morphology and architecture is poorly understood, though the spatial location of ‘new’ SOM is known to affect N and C dynamics and soil structural stability. The effect of litter quality on residue decomposition is poorly understood.
- There are some methodological problems that cannot be explored fully with laboratory tests, e.g. to what extent can soil incubation results be used to understand field processes? Moreover, more research is needed on the role of living roots in determining: i) N uptake and competition with microbial N immobilization; ii) root exudation, which is likely to interact with other OM substrates for microbial activity; and iii) extension of the rhizosphere and interaction with the soil-surface litter layer
- Biological activity (by microbes and fauna) performs functions that not only influence N and C fluxes, OM transformations, and nitrification and denitrification potentials, but also explains the status and fate of mineral N. As all these components depend partly on farming practices (e.g. C inputs from cattle excreta), the accuracy of C budgets must be improved to accommodate the requirements of environmental policies

One of the challenges now is to develop a widely applicable scheme with measures to maintain or increase soil quality and decrease nutrient losses from grass-arable rotations under different conditions, using the ideas and results of studies in different countries. One requirement should be to optimize the length of the grass and arable period in a rotation, according to production needs and environmental considerations.

The interest in ley-arable rotations remains large in most European intensive dairy-production systems. As the average size of dairy farms increases with time, there is an increased risk of losses from the polarized use of fields (permanent grasslands near animal houses and arable rotations in the most distant fields). This trend requires new solutions for finding the best ley-arable rotations to meet several objectives: preserve soil quality and production potential, minimize N and C losses and environmental impacts, optimize nutrients and energy input efficiency, and preserve landscapes and biodiversity. System analyses are needed to evaluate the agronomic and environmental consequences of the type of arable crop in grass-arable rotations and to optimize all components of sustainable agriculture.

## References

- Aarts H.F.M., Conijn J.G. and Corré W.J. (2001) Nitrogen fluxes in the plant component of the 'De Marke'; farming systems, objectives and results. *Netherlands Journal of Agricultural Science* 49, 153-162.
- Accoe F., Boeckx P., Busschaert J., Hofman G., Cleemput O.V. (2004) Gross N transformation rates and net N mineralisation rates related to the C and N contents of soil organic matter fractions in grassland soils of different age. *Soil Biology and Biochemistry* 36, 2075-2087.
- Adams W.A., Jan M.T. (1999) Utilization of nitrogen accumulated by a clover containing ley following cultivation. *Soil Use and Management* 15, 247-253.
- Alvarez G., Chaussod R., Loiseau P. and Delpy R. (1998) Soil indicators of C and N transformations under pure and mixed grass-clover swards. *European Journal of Agronomy* 9, 157-172.
- Andriulo A., Guerif J., Mary B. (1999a) Evolution of soil carbon with various cropping sequences on the rolling pampas. Determination of carbon origin using variations in natural  $^{13}\text{C}$  abundance. *Agronomie* 19, 349-364.
- Andriulo A., Mary B., Guerif J. (1999b) Modelling soil carbon dynamics with various cropping sequences on the rolling pampas. *Agronomie* 19, 365-377.
- Antil R. S., Lovell R D., Hatch D. J., Jarvis S. C. (2001) Mineralization of nitrogen in permanent pastures amended with fertilizer or dung. *Biology and Fertility of Soils* 33, 132-138.
- Arrouays D., Balesdent J., Germon J. C., Jayet P. A., Soussana J. F., Stengel P. (2002) "Increasing carbon stocks in French agricultural soils ?" INRA et MED, Paris.
- Assman T. S., Loiseau P., Delpy R., Ollier J. L. (2002) White clover content modifies soil N mineralization in grasslands in relation with N accumulation in the SOM fractions. Durand J.L., Huyghe C., and G. Lemaire (eds), *Grassland Science in Europe*, 7, 652-653.
- Balesdent J. and Balabane M. (1996) Major contribution of roots to soil carbon storage inferred from maize cultivated soils. *Soil Biology and Biochemistry* 28, 1261-1263.
- Bhogal A., Bhogal A., Shepherd M. A., Hatch D. J., Brown L., Jarvis S. C. (2001) Evaluation of two N cycle models for the prediction of N mineralization from grassland soils in the UK. *Soil Use and Management* 17, 163-172.
- Bhogal A., Murphy D.V., Fortune S., Shepherd M.A., Hatch D.J., Jarvis S.C, Gaunt J.L., Goulding K.W.T. (2000) Distribution of nitrogen pools in the soil profile of undisturbed and reseeded grasslands. *Biology and Fertility of Soils* 30, 356-362.
- Boiffin, J., Fleury, A., (1974). Some agronomic consequences of the cultivation of permanent grassland. *Annales Agronomiques* 25, 555-573.
- Bol R., Eriksen J., Smith P., Garnett M. H., Coleman K., Christensen B. T. (2005) The natural abundance of  $^{13}\text{C}$ ,  $^{15}\text{N}$ ,  $^{34}\text{S}$  and  $^{14}\text{C}$  in archived (1923-2000) plant and soil samples from the Askov long-term experiments on animal manure and mineral fertilizer. *Rapid Communications in Mass Spectrometry* 19, 3216-3226.
- Booth M. S., Stark J. M., Rastetter E. (2005) Controls on nitrogen cycling in terrestrial ecosystems: a synthetic analysis of literature data. *Ecological Monographs* 75, 139-157.
- Brown L., Scholefield D., Jewkes E. C., Lockyer D. R., del Prado A. (2005) NGAUGE: A decision support system to optimise N fertilisation of British grassland for economic and environmental goals. *Agriculture, Ecosystems and Environment* 109, 20-39.
- Chantigny M.H. (2003) Dissolved and water-extractable organic matter in soils: a review on the influence of land use and management practices. *Geoderma* 113, 357-380.
- Conijn J. G. and Taube F. (eds) (2003) Grassland resowing and grass-arable crop rotations. Consequences for performance and Environmental. 2<sup>nd</sup> meeting of the EGF working group, Kiel, Germany, PRI report 80, 78 pp.
- Conijn J. G., Velthof G. L. and Taube F., (eds) (2002) Grassland resowing and grass-arable crop rotations. International workshop on agricultural and environmental issues", Wageningen, the Netherlands PRI report 47, 128 pp.

- Davies M.G., Smith K.A. and Vinten A.J.A. (2001) The mineralisation and fate of nitrogen following ploughing of grass and grass-clover swards. *Biology and Fertility of Soil* 33, 423-434.
- Djurhuus J., Olsen P. (1997) Nitrate leaching after cut grass/clover leys as affected by time of ploughing. *Soil Use and Management* 13, 61-67.
- Drury C.F., Yang X.M., Reynolds W.D. and Tan C.S. (2004) Influence of crop rotation and aggregate size on carbon dioxide production and denitrification. *Soil and Tillage Research* 79, 87-100.
- Eriksen J. (2001) Nitrate leaching and growth of cereal crops following cultivation of contrasting temporary grasslands. *Journal of Agricultural Science* 136, 271-281.
- Eriksen J. and Jensen L. S. (2001) Soil respiration, nitrogen mineralization and uptake in barley following cultivation of grazed grasslands. *Biology and Fertility of Soils* 33, 139-145.
- Eriksen J., Askegaard M. and Kristensen K. (2004) Nitrate leaching from an organic dairy crop rotation: the effects of manure type, nitrogen input and improved crop rotation. *Soil Use and Management* 20, 48-54.
- Fontaine S., Mariotti A. and Abbadie L. (2003) The priming effect of organic matter: a question of microbial competition? *Soil Biology and Biochemistry* 35, 837-843.
- Francis G.S. (1995) Management practices for minimizing nitrate leaching after ploughing temporary leguminous pastures in Canterbury, New Zealand. *Journal of Contaminant Hydrology* 20, 313-327.
- Gill R. A., Kelly R. H., Parton W. J., Day K. A., Jackson R. B., Morgan J. A., Scurlock J. M. O., Tieszen L. L., Castle J. V., Ojima D. S., Zhang X. S. (2002) Using simple environmental variables to estimate below-ground productivity in grasslands. *Global Ecology and Biogeography* 11, 79-86.
- Hatch D. J., Boghal A., Lovell R. D., Shepherd M. A., Jarvis S. C. (2000a) Comparison of different methodologies for field measurement of net nitrogen mineralization in pasture soils under different soil conditions. *Biology and Fertility of Soils* 32, 287-293.
- Hatch D. J., Lovell R. D., Antil R. S., Jarvis S. C. and Owen P. M. (2000b) Nitrogen mineralization and microbial activity in permanent pastures amended with nitrogen fertilizer or dung. *Biology and Fertility of Soils* 30, 288-293.
- Hatch D. J., Sprosen M. S., Jarvis S. C., Ledgard S. F. (2002) Use of labelled nitrogen to measure gross and net rates of mineralization and microbial activity in permanent pastures following fertilizer applications at different time intervals. *Rapid Communications in Mass Spectrometry* 16, 2172-2178.
- Haynes R. J. (2005) Labile organic matter fractions as central components of the quality of agricultural soils: An overview. *Advances in Agronomy* 85, 221-268.
- Hoogerkamp M., (1973) Accumulation of organic matter under grassland and its effects on grassland and on arable crops. Agricultural Research Report 806, PUDOC, Wageningen.
- Hopkins A., Gilbey J., Dibb C., Bowling P. J., Murray P. J. (1990) Response of permanent and reseeded grassland to fertilizer nitrogen. 1. Herbage production and herbage quality. *Grass and Forage Science* 45, 43-55.
- Janzen H. H. (2006) The soil carbon dilemma: Shall we hoard it or use it? *Soil Biology and Biochemistry* 38, 419-424.
- Jenkinson D. S. and Rayner J. H. (1977) The turnover of soil organic matter in some of the Rothamsted classical experiments. *Soil Science* 123, 298-305.
- Jenkinson D. S., Bradbury N. J. and Coleman K. (1994) How the Rothamsted Classical Experiments have been used to develop and test models for the turnover of carbon and nitrogen in soil. In "Long-term Experiments in Agricultural and Ecological Sciences" (R. A. Leigh and A. E. Johnston, eds.), pp. 117-138. CAB International.
- Johnston A. E. (1986) Soil organic matter, effects on soils and crops. *Soil Use and Management*, 2 (3), 97-105
- Johnston A.E., McEwen J., Lane P.W., Hewitt M.V., Poulton P.R., Yeoman D.P. (1994) Effects of one to six years old ryegrass-clover leys on soil nitrogen and on the subsequent yields and fertilizer nitrogen requirements of the arable sequence winter wheat, potatoes, winter wheat, winter beans grown on a sandy loam soil. *Journal of Agricultural Science* 122, 73-89.
- Kalbitz K., Solinger S., Park J. H., Michalzik B. and Matzner E. (2000) Controls on the dynamics of dissolved organic matter in soil: A review. *Soil Science* 165, 277-304.
- Katterer T. and Andren O. (1999) Long-term agricultural field experiments in Northern Europe: analysis of the influence of management on soil carbon stocks using the ICBM model. *Agriculture, Ecosystems and Environment* 72, 165-179.
- Katterer T. and Andren O. (2001) The ICBM family of analytically solved models of soil carbon, nitrogen and microbial biomass dynamics -- descriptions and application examples. *Ecological Modelling* 136, 191-207.
- Kell R. H., Parton W. J., Crocker G. J., Grace P. R., Klir J., Korschens M., Poulton P. R. and Richter D. D. (1997) Simulating trends in soil organic carbon in long-term experiments using the century model. *Geoderma*, 81, 75-90.
- Kuzyakov Y., Ehrensberger H. and Stahr K. (2001) Carbon partitioning and below-ground translocation by *Lolium perenne*. *Soil Biology and Biochemistry* 33, 61-74.

- Larson J. A., Roberts R. K., Tyler D. D., Duck B. N., Slinsky S. P. (1998) Nitrogen-fixing winter cover crops and production risk: a case study for no-tillage corn. *Journal of Agricultural and Applied Economics* 30 (1), 163-174
- Lamandé M., Hallaire V., Curmi P., Pérès G. and Cluzeau D. (2003) Changes of pore morphology, infiltration and earthworm community in a loamy soil under different agricultural managements. *Catena*, 54, 637-649.
- Laurent F., Kerveillant P.B. A., Vertès F., Mary B. and Recous S. (2004) Effet de la destruction de prairies pâturées sur la minéralisation de l'azote : approche au champ et propositions de quantification. Synthèse de 7 dispositifs expérimentaux. *Research Report Arvalis - INRA - Chambres d'agriculture de Bretagne*, 76 pp.
- Leach K. (2002) The Coates Farm Study II: Nitrogen flows in a changing mixed farming system. 1st Annual Report to DEFRA, unpublished, 26 pp.
- Lemaire G. (1999) Les flux de tissus foliaires au sein des peuplements prairiaux. Eléments pour une conduite raisonnée du pâturage. *Fourrages* 159, 203-222.
- Li Y. (2000) Modeling trace gas emissions from agricultural systems. *Nutrient Cycling in Ecosystems*, 58, 259-276.
- Lloyd A. (1992) Nitrate leaching under arable land ploughed out from grass. *Proceedings Fertilizers Society*, 330, 32 pp.
- Loiseau P. and Soussana J. F. (1999a) Elevated [CO<sub>2</sub>], temperature increase and N supply effects on the accumulation of below-ground carbon in a temperate grassland ecosystem. *Plant and Soil* 212, 123-134.
- Loiseau P. and Soussana J. F. (1999b) Elevated [CO<sub>2</sub>], temperature increase and N supply effects on the turnover of below-ground carbon in a temperate grassland ecosystem. *Plant and Soil* 210, 233-247.
- Loiseau P., Chaussod R., Delpy R. (1994) Soil microbial biomass and *in situ* nitrogen mineralization after 20 years of different nitrogen fertilization and forage cropping systems. *European Journal of Agronomy* 3, 327-332.
- Loiseau P., Louault F., Le Roux X. and Bardy M. (2005) Does extensification of rich grasslands alter the C and N cycles, directly or via species composition? *Basic and Applied Ecology* 6, 275-287.
- Loiseau P., Soussana J. F., Casella E. and Chaussod R. (1995) Evolution des stocks de matières organiques sous prairies : quantification, évolution, modélisation *Les Dossiers de l'Environnement, INRA* 10, 57-77.
- Ma L., Shaffer M.J. (2001) A review of carbon and nitrogen processes in nine U.S. soil nitrogen dynamics models. In "Modeling carbon and nitrogen dynamics for soil management", M.J. Shaffer, L. Ma and S. Hansen (eds) Boca Raton, US, Lewis publishers, 55-102.
- Mary B., Recous S. (1994) Measurement of nitrogen mineralization and immobilization fluxes in soil as a means of predicting net mineralization. *European Journal of Agronomy* 3, 291-300.
- Mary B., Beaudoin N., Justes E. and Machel J. M. (1999) Calculation of nitrogen mineralization and leaching in fallow soil using a simple dynamic model. *European Journal of Soil Science* 50, 549-566.
- McGechan M.B. and Wu L. (2001) A review of carbon and nitrogen processes in European soil nitrogen dynamics models. In "Modeling carbon and nitrogen dynamics for soil management", M.J. Shaffer, L. Ma and S. Hansen (eds) Boca Raton, US, Lewis publishers, 103-171.
- Morvan T. and Alard V., Ruiz L. (2000) Intérêt environnemental de la betterave fourragère. *Fourrages* 163, 315-322.
- Munch J.C. and Velthof G. L. (2007) Denitrification and agriculture, "Biology of the nitrogen cycle", Bothe, H., Ferguson, S., Newton, V. (eds.), Elsevier, p.331- 343.
- Nevens F. and Reheul D. (2002) The nitrogen- and non-nitrogen-contribution effect of ploughed grass leys on the following arable forage crops: determination and optimum use. *European Journal of Agronomy* 16, 57-74.
- NGuyen C. (2003) Rhizodeposition of organic C by plants: mechanisms and controls. *Agronomie* 23, 375-396.
- Parsons A. J., Harvey A. and Woledge J. (1991) Plant-animal interactions in a continuously grazed mixture. I. Differences in the physiology of leaf expansion and the fate of leaves of grass and clover. *Journal of Applied Ecology* 28, 619-634.
- Patra A. K., Jarvis S. C. and Hatch D. J. (1999) Nitrogen mineralization in soil layers, soil particles and macro-organic matter under grassland. *Biology and Fertility of Soils* 29, 38-45.
- Paustian K., Andren O., Clarholm M., Hansson A. C., Johansson G., Lagerlof J., Lindberg T., Pettersson R. and Sohlenius B. (1990) Carbon and nitrogen budgets of four agro-ecosystems with annual and perennial crops, with and without N fertilization. *Journal of Applied Ecology* 27, 60-84.
- Paustian K., Elliott E. T., Collins H. P., Cole C.V. Paul, E. A. (1995) Use of a network of long-term experiments for analysis of soil carbon dynamics and global change: the North American model. *Australian Journal of Experimental Agriculture* 35, 929-939.
- Personeni E. L., P. (2004) How does the nature of living and dead roots affect the residence time of carbon in the root litter continuum? *Plant and Soil* 267, 129-141.
- Recous S. (2005) Soil microbial biomass: its role in nitrogen cycling and efficiency. *Proceedings of the International Fertiliser Society Conference*, 14-16 December 2005, vol. 566, pp. 1-20.
- Rees R. M., Bingham I. J., Baddeley J. A., Watson C. A. (2005) The role of plants and land management in sequestering soil carbon in temperate arable and grassland ecosystems. *Geoderma* 128, 130-154.

- Reicosky D. C., Dugas W. A. and Torbert H. A. (1997) Tillage-induced soil carbon dioxide loss from different cropping systems. *Soil and Tillage Research* 41, 105-118.
- Rodrigo A., Recous S., Neel C., Mary B. (1997) Modelling temperature and moisture effects on C-N transformations in soils: comparison of nine models. *Ecological Modelling* 102, 325-339.
- Schils R. L. M., Verhagen A., Aarts H. F. M., Kuikman P. J. and Sebek L. B. J. (2006) Effect of improved nitrogen management on greenhouse gas emissions from intensive dairy systems in the Netherlands. *Global Change Biology* 12, 382-391.
- Scholefield D., Lockyer D. R., Whitehead D. C. and Tyson K. C. (1991) A model to predict transformations and losses of nitrogen in UK pastures grazed by beef cattle. *Plant and Soil* 132, 165-177.
- Sebillotte M. (1980) The role of grasslands in crop rotations. *Fourrages* 83, 79-124.
- Shepherd M. A., Hatch D. J., Jarvis S. C. and Bhogal A. (2001) Nitrate leaching from reseeded pasture. *In Soil Use and Management*, Vol. 17, 97-105.
- Six J., Feller C., Denef K., Ogle S. M., Moraes Sa J. C. d. and Albrecht A. (2002) Soil organic matter, biota and aggregation in temperate and tropical soils - Effects of no-tillage. *Agronomie* 22, 755-775.
- Smith P., Smith J.U., Powlson D.S., McGill W.B., Arah J.R.M., Chertov O.G., Coleman K., Franko U., Froking S., Jenkinson D.S., Jensen L.S., Kelly R.H., Klein-Gunnewiek H., Komarov A.S., Li C., Molina J.A. E., Mueller T., Parton W.J., Thornley J.H.M., Whitmore A. P. (1997) A comparison of the performance of nine soil organic matter models using datasets from seven long-term experiments. *Geoderma* 81, 153-225.
- Soegaard K., Jorgensen V., Thomsen P. C. (1988) Irrigation, nitrogen and cutting management in grass and clover/grass. Proceedings of the 12th General Meeting of the European Grassland Federation, Dublin, Ireland, July 4-7, 262-266.
- Springhob G., Kirchmann H. (2003) Organic C and N stocks and their long term changes in sandy soils of North Germany. In Conijn J. G., Taub, F. (eds) Grassland resowing and grass-arable crop rotations, PRI report 80, 41-47.
- Stockdale E. A., Hatch D. J. M., Daniel V., Ledgard S. F and Watson C. J. (2002) Verifying the nitrification to immobilisation ratio (N/I) as a key determinant of potential nitrate loss in grassland and arable soils. *Agronomie* 22, 831-838.
- Stapledon R. G. (1935) *The Land-Now and Tomorrow*. Faber and Faber.
- Stopes C., Lord E.I., Philipps L. and Woodward L. (2002) Nitrate leaching from organic farms and conventional farms following best practice. *Soil Use and Management* 18, 256-263.
- Thornley J. H. M. and Verberne E. L. J. (1989) A model of nitrogen flows in grassland. *Plant, Cell and Environment* 12, 863-886.
- Tlustos P., Willison T. W., Baker J. C., Murphy D. V., Pavlikova D., Goulding K. W. T., and Powlson D. S. (1998) Short-term effects of nitrogen on methane oxidation in soils. *Biology and Fertility of Soils* 28, 64-70.
- Trinsoutrot I., Recous S., Bentz B., Lineres M., Cheneby D., Nicolardot B. (2000) Biochemical quality of crop residues and carbon and nitrogen mineralization kinetics under nonlimiting nitrogen conditions. *Soil Science Society of America Journal* 64, 918-926.
- Tyson K.C., Roberts D.H., Clement C.R. and Garwood E.A. (1990) Comparison of crop yields and soil conditions during 30 years under annual tillage or grazed pasture. *Journal of Agricultural Science* 115, 29-40.
- Van Burg P.F.J., Arnold G.H. (eds), (1966). Nitrogen and Grassland. Proceedings of the 1<sup>st</sup> general meeting of the European Grassland Federation, Wageningen, 1965.
- Van Dijk W., Hofman T.B., Nijssen K., Everts H. , Wouters A.P., Lamers J.G., Alblas J. and Bezooijen J. (1996) Effecten van mais-gras Vruchtwisseling. Verslag Proefstation voor de Akkerbouw en de Groenteteelt in de Vollegrond No. 217, 140 pp.
- Van Soest P. J. (1963) Use of detergents in the analysis of fibrous feeds. II. A rapid method for the determination of fiber and lignin. *Journal of the A.O.A.C.* 46, 829-835
- Vellinga T.V., Pol-van Dasselaar A.V.D., Kuikman P.J. (2004) The impact of grassland ploughing on CO<sub>2</sub> and N<sub>2</sub>O emissions in the Netherlands, *Nutrient cycling in Agroecosystems* 70, 33-45.
- Velthof G. L. and Oenema O. (2001) Effects of ageing and cultivation of grassland on soil nitrogen. *Alterra-rapport* 399, 1-53.
- Velthof G. L., van Groenigen J. W., Gebauer G., Pietrzak S., Jarvis S. C., Pinto M., Corre W. and Oenema O. (2000) Temporal stability of spatial patterns of nitrous oxide fluxes from sloping grassland. *Journal of Environmental Quality* 29, 1397-1407.
- Vertès F., Mary B. (2007) Modelling the long term SOM dynamics in fodder rotations with a variable part of grassland. *In "Organic Matter Symposium"*, 17-19 July 2007, Poitiers, France.
- Vertès F., Laurent F., Recous S., Leterme P. and Mary B. (2001) Nitrogen mineralization under bare soils after the destruction of grazed pastures. *In "Sustainable management of soil organic matter"*. Rees, R.M., Ball .B.C., Campbell C.D. and Watson C.A. (eds), CABI publishing, London. 240-246.

- Vertès F., Menasseri S. and Morvan T. (2005) Long term effect of the length of the grass period in ley-arable rotations on the quality of soil organic matter. In "14th N workshop" (J. J. Schröder and J. J. Neeteson, eds.), Vol. 116, pp. 219-222. PRI, Maastricht, NL.
- Vinten A. J. A., Ball B. C., O'Sullivan M. F., Henshall J. K., Howard R., Wright F. and Ritchie R. (2002) The effects of cultivation method and timing, previous sward and fertilizer level on subsequent crop yields and nitrate leaching following cultivation of long-term grazed grass and grass-clover swards. *Journal of Agricultural Science* 139, 245-256.
- Walter C., Rossel R. A. V. and McBratney A. B. (2003). Spatio-temporal simulation of the field-scale evolution of organic carbon over the landscape. *Soil Science Society of America Journal* 67, 1477-1486.
- Warembourg F. R., Roumet C. and Lafont F., (2003) Differences in rhizosphere carbon-partitioning among plant species of different families. *Plant and Soil* 256, 347-357.
- Watson C.A., Fowler S.M. and Wilman D. (1993) Soil inorganic-N and nitrate leaching on organic farms. *Journal of Agricultural Science, Cambridge* 120: 361-369.
- Webster C. P., Poulton P. R and Goulding K. W. T. (1999) Nitrogen leaching from winter cereals grown as part of a 5-year ley-arable rotation. *European Journal of Agronomy* 10, 99-109.
- Whitehead D. C., Garwood E. A. and Ryden J. C. (1986) The efficiency of nitrogen use in relation to grassland productivity. *Research review*.
- Whitehead D. C., Bristow A. W. and Lockyer D. R. (1990) Organic matter and nitrogen in the unharvested fractions of grass swards in relation to the potential for nitrate leaching after ploughing. *Plant and Soil* 123, 39-49
- Young C.P. (1986) Nitrate in groundwater and the effects of ploughing on release of nitrate. In "Effects of land use on fresh waters: agriculture, forestry, mineral exploitation, urbanisation. Ellis Horwood Series in Water and Wastewater Technology", de L.G. Solbe (ed.), 221-237.

# Soil biota in grassland, its ecosystem services and the impact of management

van Eekeren N.<sup>1</sup>, Murray P.J.<sup>2</sup> and Smeding F.W.<sup>1</sup>

<sup>1</sup>*Louis Bolk Institute, Dept. Organic Agriculture, Hoofdstraat 24, NL-3972 LA Driebergen, The Netherlands*

<sup>2</sup>*Cross-Institute Programme for Sustainable Soil Function, Institute of Grassland and Environmental Research, North Wyke Research Station Okehampton Devon, EX20 2SB, UK*

## Abstract

In the search for sustainable grassland systems, self-regulating processes in the soil become increasingly important. Soil biota play an important role in these processes and in the provision of various ecosystem services. For grassland systems important ecosystem services are supply of nutrients, soil structure maintenance and water retention. For developing and optimising sustainable grassland systems, insight is needed into the mechanisms by which soil biota are influenced by management and what it means for the functioning of the soil-plant system. Interactions between soil and plants can be represented by a cyclic conceptual framework including plant/roots, soil biota and soil properties. The challenge for sustainable grassland is to allow this cycle to function optimally with a minimum of external inputs. In these systems the soil food web is probably bacterial-based with a high density of earthworms. The impacts of grassland management on soil biota are discussed on the basis of two cases: use of grass-clover mixtures and a ley-arable crop rotation versus permanent grassland and continuous arable land.

Keywords: grassland, management, soil biota, ecosystem services

## Introduction

In intensive grassland systems, the importance of soil organisms has often been ignored, as physical manipulation of the soil and nutrient supply have been increasingly provided by human inputs rather than by natural processes (Brussaard *et al.*, 1997). In the search for sustainable agricultural grassland systems, self-regulating processes in the soil become more and more important (Yeates *et al.* 1997). Soil biota play an important role in these processes and in the provision of various ecosystem services: supply of nutrients, maintenance of soil structure, water regulation and, more generally the resistance and resilience of the belowground system (Brussaard *et al.*, 1997; Mulder *et al.*, 2006). For developing and optimising sustainable grassland systems, insight is needed into the mechanisms by which soil biota are influenced by management and what these mean for the functioning of the plant-soil system (Bardgett, 1996). This would allow us to make better use of the ecosystem services provided by soil biota and compensate for grassland systems that are developed in one direction (e.g. nitrogen use efficiency), with possible adverse effects on soil biota. This paper aims to outline the causal relations between grassland management, soil food web and ecosystem services. Therefore first information on the soil food web and ecosystem services will be reviewed briefly. Subsequently a conceptual framework is proposed in regard to cyclic plant-soil interactions under a grassland system. The application of this concept is shown by means of two examples of management measures: the use of grass-clover mixtures and a ley-arable crop rotation versus permanent grassland and continuous arable land.

## Soil biota

The living biomass of soil biota on conventional dairy farms in the Netherlands is on average 2656 kg soil biota ha<sup>-1</sup> in sandy soils and 3908 kg soil biota ha<sup>-1</sup> in clayey soils (Schouten *et al.*, 2000; Schouten *et al.*, 2002). These quantities exceed the weight of the livestock kept aboveground on these grasslands. According to Schouten *et al.* (2000; 2002) the live biomass of soil biota in sandy soils consisted of 81% bacteria and 13% earthworms and in clay soil data were 77% and 22% respectively. The remainder was made up of enchytraeids, mites, collembola and nematodes. Fungi and protozoa were not measured. However, recent analysis of organic dairy farms on sandy soils demonstrated that fungi contribute to 22 % of the total microbial biomass (De Vries *et al.* 2007).

Table 1. Soil biota in the soil (layer 0-10 cm, 0-15 cm earthworms) of 19 conventional dairy farms on sandy soil and 20 on clayey soil (Schouten *et al.*, 2000; Schouten *et al.*, 2002)

Classification	Biota	Units	Sand (n=19)	Clay (n=20)
Microflora	Bacteria	$\mu\text{g C g dry soil}^{-1}$	169	233
	Fungi		Not analysed	
Microfauna <200 $\mu\text{m}$	Protozoa	$\text{n } 100\text{g soil}^{-1}$	Not analysed	
	Nematodes		5464	4629
Mesofauna 100 $\mu\text{m}$ -2mm	Mites+Collembola	$\text{n m}^{-2}$	39722	37900
	Enchytraeids	$\text{n m}^{-2}$	17877	24908
Macrofauna > 2mm	Earthworms	$\text{n m}^{-2}$	148	318

Size relationships play an important role in biological interactions in soil, because the habitat is composed of differently-sized pores (Brussaard *et al.*, 1997). Soil biota can be classified by means of body width into microfauna, mesofauna and macrofauna (Table 1). In regard to feeding relations soil biota can be classified in functional groups. The interrelationships of the different functional groups are complex and can be seen more clearly in the context of the food chains or the soil food web (De Ruiter, 1993).

## Ecosystem services of soil biota

Important ecosystem services of soil biota for grassland systems are nutrient cycling, soil structure maintenance and water regulation. In grassland, the focus is on soil structure maintenance and water regulation, because of the perennial nature of the crop with no regular cultivation coupled with the compaction from animal trampling and tractor usage. In this paragraph, the contribution of microflora, nematodes and earthworms to these three ecosystem services in grassland is reviewed.

### Nutrient cycling

For the ecosystem service of nutrient cycling all groups of soil biota are involved. Bacteria and fungi directly govern this service, via nutrient mineralization and immobilisation. De Ruiter *et al.* (1993) estimated that the contribution by bacteria to N-mineralization is 20 to 140 kg N ha<sup>-1</sup> yr<sup>-1</sup>. The lower contribution by fungi to N-mineralization (1 to 24 kg N ha<sup>-1</sup> yr<sup>-1</sup>) is partly compensated for by a more efficient nutrient uptake of plants through the symbioses with mycorrhizal fungi. For example, Van der Heijden *et al.* (1998) measured positive effects on shoot phosphorous concentrations and shoot biomass of mycorrhizal species on grasses such as *Bromus* spp. and *Festuca* spp.

Nematodes and protozoa, affect nutrient cycling processes indirectly through the grazing of the soil microbial biomass and through excretion of nutrient rich waste. Griffiths (1989)



observed that the nitrogen content of ryegrass increased by 14% when nematodes or protozoa were added to microcosms with bacteria. Ingham *et al.* (1985) found increased grass and root growth when nematodes were added to a microcosm with bacteria. Not only microbivorous nematodes are involved in nutrient cycling. In experiments with clover, low levels of root infestation by clover cyst nematode (*Heterodera trifolii*) positively influenced the rhizosphere microbial community in the soil (Yeates *et al.*, 1998a; Denton *et al.*, 1999) and increased the root growth of white clover and perennial ryegrass with 141% and 219% respectively (Bardgett *et al.*, 1999a). Associated with this improvement in root production was a 322% increase in uptake of white clover derived <sup>15</sup>N. Similar results have been demonstrated for larger invertebrates, for example the larvae of the clover root weevil (*Sitona lepidus*) have been shown to facilitate the transfer of nitrogen from clovers to companion ryegrass (Murray and Hatch, 1994; Murray and Clements 1998).

Mesofauna and macrofauna affect nutrient cycling processes directly by fragmentation and transport of organic and mineral particles, and indirectly by regulating the microbial population and stimulating the microbial activity. Earthworms stimulate microflora in the structures that they create (Brown, 1995). Especially in grassland the function of fragmentation of organic matter by earthworms is important for breaking down the turf matt. Hoogerkamp *et al.* (1983) observed that, after the introduction of earthworms on reclaimed polder soils, in approximately three years a dark-coloured top soil started to develop. In an experiment of Clements *et al.* (1991) the most apparent effect of a pesticide treatment that excluded earthworms, was the accumulation of litter. Next to fragmentation, the transport and mixing of organic and mineral particles is an important function of earthworms. In a glasshouse study with perennial ryegrass and phosphate rock, it was shown that a treatment with earthworms had a higher yield, not only through the mixing of the phosphate rock but also by an increased extractability of P (Mackay *et al.*, 1982).

### Soil structure

In regard to the ecosystem service of soil structure maintenance, there is evidence that bacteria produce compounds that bind aggregates and that fungal hyphae attach particles to aggregates. Mäder *et al.* (2002) found in arable crops a positive correlation between aggregate stability and microbial biomass. Specific for mycorrhizal fungi, Tisdall and Oades (1979) measured under perennial ryegrass and white clover a positive relation between hyphal length and water stable aggregates.

Cole *et al.* (2006) concluded from their research at Sourhope that the macrofauna, particularly earthworms, has a more profound effect on the soil structure than the microflora. Earthworms affect soil structure through the production of faecal pellets, promotion of humification and creation of pores for movement of air, water and nutrients. An apparent example for the effect of earthworms on soil structure is the effect of artificially introduced earthworms in grasslands on reclaimed land (Hoogerkamp *et al.*, 1983). Here earthworm presence related to an increased infiltration capacity, an improved permeability and aeration of the upper soil layers and a considerable decrease in soil penetration resistance. Similar effects were reported in an experiment by Clements *et al.* (1991) in which the 20 years' absence of earthworm and other invertebrates, due to a pesticide treatment, increased soil bulk density, penetrability and reduced soil organic matter content, initial infiltration rate, pH and soil moisture content.

## Water regulation

The function of water regulation is closely linked to the above described functions of soil structure maintenance and nutrient cycling. For example, a better aggregate stability improves the water retention or through an improved nutrient intake of plants by mycorrhizal fungi, plants become less vulnerable to the first drought stress (Smith and Read, 1997). An example of the effect of soil biota on water regulation is the increased water logging in Scottish grasslands due to the flatworm predation on earthworms (Haria *et al.*, 1998). Water infiltration through burrows and stable crumb formation are two key soil factors strongly affected by earthworms. Bouché and Al-Addan (1997) correlated infiltration rate to earthworm biomass and calculated a mean rate of 150 mm water h<sup>-1</sup> per 100 g m<sup>-2</sup> earthworms. Earthworm activity may attribute to improvement of infiltration resulting in a reduced runoff. However, these effects on macropore formation can also lead to an increased bypass flow and greater leaching of nutrients. (Edwards *et al.*, 1992).

The rooting depth of grass roots is especially important for the drought resistance of grassland. Earthworm burrows create pathways for the penetration of roots through the soil. Channels of the deep-burrowing, surface-feeding earthworms (*Lumbricus terrestris* and *Aporrectodea longa*) are generally vertical and may penetrate a hard pan. In several pot and field studies increased root growth has been measured in response to earthworm inoculation (Logsdon and Linden, 1992).

## **Plant-soil interactions**

The influence of grassland management on soil biota can not be seen apart from effects on the grass sward. There is an intimate link between soil organisms and the grass plant. In this paragraph different plant-soil interactions are illustrated and elaborated in a conceptual framework.

Through root exudates and litter from roots and aboveground parts, grasses supply nutrients to the soil food web. Deinum (1985) calculated that from a perennial ryegrass sward 4500 kg organic root mass ha<sup>-1</sup> is decomposed on a yearly basis. According to Whipps (1990) approximately 35-80% of the net fixed C in perennial grasses is transferred below ground. The quantity and quality (including plant secondary metabolites) of root exudates and plant litter are the major factors which determine the soil food web and its diversity under a specific plant species and even different grass species (Bardgett, 2005). These effects can be illustrated with various experiments in which was shown that single species of grassland plants differed markedly in their impact on soil microbes (Bardgett *et al.*, 1999b), nematodes (Wasilewska, 1995) and enchytraeids (Griffiths *et al.*, 1992). Next to a source of food, grass roots are a host for many soil organisms such as root pathogens, root herbivores, and symbiotic soil biota. Therefore the rhizosphere is one of the “hot spots” for biological activity (Beare, 1995). In turn, soil biota, influence grass production and quality through their ecosystem services and antagonistic relations from root herbivores. By means of these processes, the soil biota also influence the composition of grassland plant communities. For example Grime *et al.* (1987) showed in a microcosm experiment, that the presence of mycorrhizal fungi lead to a shift in plant composition.

With this the circle is accomplished; plants influence, through the quantity and quality of root exudates and litter, the soil biota and its diversity. The soil biota in turn influence with their ecosystem services and antagonistic relations, the plant production, plant quality and diversity

of the plant community. In regard to earthworms, Syers and Springett (1983) concluded that these plant-soil relationships concerning earthworms are interactive, cyclical and complex. Bardgett and Wardle (2003) elaborated the links between grazers, plants and soil for the decomposer organism. An illustrative example for these links is revealed by an experiment of Hamilton and Frank (2001) in which grazing of *Poa pratensis* promoted root exudation. This stimulated microbial biomass in the root zone which in turn increased soil N availability and plant N acquisition, which resulted in grass growth. Brussaard (1998) combined the soil-plant interactions from “decomposers” in a diagram with the interactions of “root-biota” including the root herbivores and “ecosystem engineers” including the earthworms. In this diagram Brussaard (1998) considered plant roots as ecosystem engineers since they create habitats for other organisms. A conceptual framework is proposed in which the diagram of Brussaard (1998) is worked out in a cyclical process according to Syers and Springett (1983) for a grassland sward (Figure 1). Through plants and roots, and interactions with soil biota, food and habitat for biota is delivered to the soil. Through the improvement of nutrient cycling, soil structure and water retention by soil biota, plant rooting is increased and the intake of nutrient and water through plants is increased. Finally this results in a greater plant yield which means again an increase in litter and root exudates in quantity and quality. The challenge for sustainable grassland management is to allow this cycle to function optimally with a minimum of external inputs. It can be compared to cranking up of an engine, once the flywheel is turning, the engine can continue at a low speed with minimal inputs and even sustain minor disturbances. For a grassland the grassroots are a major link between the aboveground and belowground system. When the roots fail to grow the cycle shuts down.

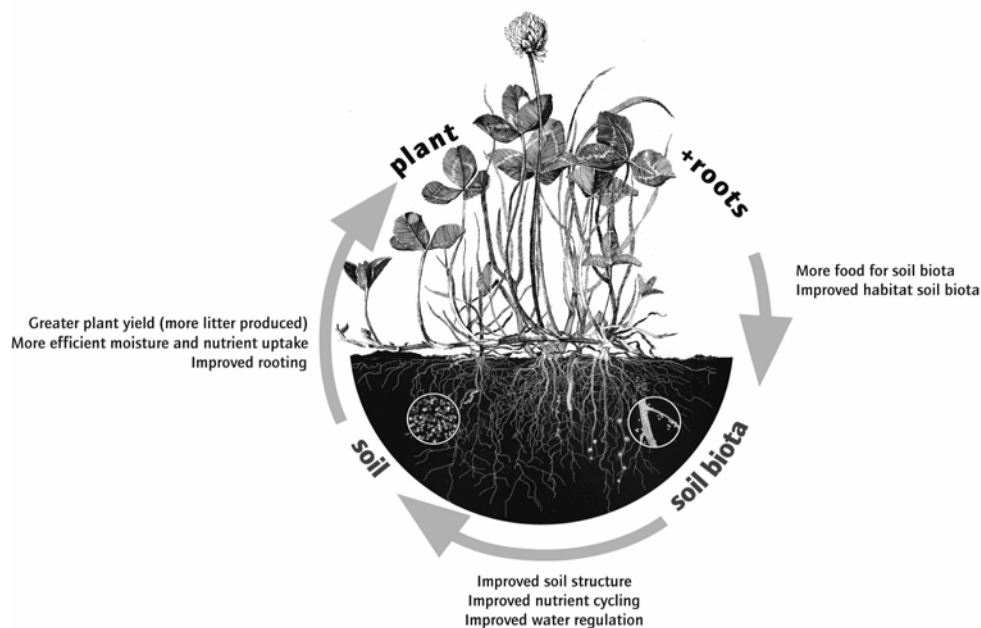

Figur 1. Cyclic interactions between plant/roots, soil biota (root biota, decomposers and ecosystem engineers) and soil properties (chemical and physical).

In agreement with Wardle *et al.* (2004) it is assumed that the bacterial-based soil food web with a high density of earthworms, delivers the ecosystem services that go together with the optimal functioning of these plant-soil cycle. More precisely this means a fast nutrient cycling process, maintenance of soil structure and water regulation. In the comparison of ecological interactions between aboveground and belowground biota, Wardle *et al.* (2004) make a distinction between fertile systems that support high herbivory and infertile habitats that support low herbivory. Ecosystems dominated with plant species adapted to fertile conditions

('mull sites'), have a high litter quantity and quality, and support soil food webs with a bacterial-based energy channel, microfauna (nematodes and protozoa) and a high density of earthworms. On the contrary infertile soils ('mor sites'), support plants with low litter quantity and quality, and tend to support soil food webs dominated by fungi and arthropods such as mites and collembolans (Wardle, 2002). The interaction between the aboveground and belowground biota in the infertile, unproductive ecosystems are negative and in the fertile, productive ecosystems positive (Wardle *et al.*, 2004). These positive interactions are just the cyclic aspects needed for a sustainable agricultural grassland.

### **Impact of grassland management on soil biota and its services**

In this paragraph the effect of two common grassland management measures on soil biota and its services are discussed. Management affects soil biota directly (e.g. via soil qualities) and indirectly (e.g. via the cycle plant-soil interactions). For example in an upland grassland in the Scottish Borders, lime application had both direct effects on the enchytraeid community structure by soil chemical qualities as well as on the nematode community structure by an increased plant production and root turn-over (Cole *et al.*, 2006; Murray *et al.* 2006).

#### Use of grass-clover mixtures

The primary motive to use clover is its ability for N-fixation, in order to reduce the reliance on artificial fertilizer. However, indirectly white clover possibly alters the soil biota through the quality and quantity of litter and root exudates. At one side the root density of white clover is considerably lower than from grass (Evans, 1977; Tisdal and Oades, 1979; Schortemeyer *et al.*, 1997). This suggests that the quantity of litter from roots is lower. On the other hand the litter quality of white clover is better than grass, because of a lower C/N ratio (Neergaard *et al.*, 2002). Leaf litter from a *Trifolium* species showed a higher Substrate Induced Respiration (SIR, a relative measure of active microbial biomass) compared to litter from a grass (Beare *et al.*, 1990). In a microcosm study, with comparable root weights for grass and white clover, a higher microbial biomass for clover was found (Mawdsly and Bardgett, 1997). Tisdal and Oades (1979) reported in a pot experiment that white clover roots had a higher infection with mycorrhiza fungi (50.8%) compared with ryegrass roots (13.3 %). However, because the ryegrass had eight times the length of root of white clover, the total length of infected root of ryegrass was twice that of white clover.

In a field study with pure grass and grass-white clover mixtures, De Vries *et al.* (2006) found a higher microbial biomass with a higher fungal:bacterial ratio in pure grass. Elgersma and Hassink (1997) determined no difference between microbial biomass under grass or grass-clover but the amount of active microbial biomass was higher under mixtures. Salamon *et al.* (2004) found at the Swiss BIODDEPTH site an increase in the number of collembola in the presence of legumes, benefiting from high litter quality and increased microbial biomass in the rhizosphere of these plants. In different field experiments, a higher biomass of earthworms was found in grass-clover mixtures compared to pure grass (Sears, 1950; Yeates *et al.*, 1998b; Baars, 2002; Van Eekeren *et al.*, 2005). Here also specific litter quantity can play a profound role.

What would the increase in the number of earthworms mean for the ecosystem services in the plant-soil cycle when clover is introduced? Possible this could enhance the plant-soil cycle with the function of soil structure maintenance and water regulations under grasslands. Mytton *et al.* (1993) tested the hypothesis that clover is more effective than ryegrass in

developing rapid improvements in soil structure. Significant differences in drainage rates supported the hypothesis whereas no differences in bulk density, porosity or aggregate stability between the treatments were found. Soil moisture characteristic curves indicated that a more free-draining-structure develops under clover than under grass due to a higher ratio of macro- to micropores.

In conclusion, the results suggest that introduction of white clover in a grass sward reduces the root density but due to the better litter quality, the differences in microflora between grass and grass-clover mixtures in the field are small. However, the biomass of earthworms seems to increase which has, together with other soil biota, a positive impact on the ecosystem service of water regulation. Herewith, the introduction of white clover can be a tool to enhance the cycle of plant-soil interactions.

#### Ley-arable crop rotation versus permanent grassland and permanent cropping

Conventional and organic dairy farms, with grass and maize, show an increasing interest for ley-arable crop rotations, because of an improved nitrogen use efficiency (Neuens and Reheul, 2002). Also improved conditions for clover as well as the opportunity for mechanical weed control are motives (Younie and Hermansen, 2000). However, what is the impact on soil biota, its services and the plant-soil cycle, when on farm level permanent grassland and continuous maize cropping is changed to ley-arable cropping?

The soil food web under permanent grassland is completely different from continuous arable land. Fromm *et al.* (1993) showed that the type of land use (grassland versus arable land) even had more influence on soil biota than different soil types with the same land use. In the Dutch Soil Quality Monitoring Network the bacterial biomass was 50-100% higher in grassland than in arable land while the bacterial activity was higher in arable land (Bloem *et al.*, 2006). In the same study higher numbers of nematodes in grassland compared to arable land were measured (Schouten *et al.*, 2004). Juma and Mishra (1988) assessed a dominance of herbivorous nematodes under a perennial crop and bacterivorous nematodes under arable land. Different authors (Low, 1972; Yeates *et al.*, 1998b; Lamandé *et al.*, 2003) found earthworms to be more abundant under long-term pasture than under long-term cropping. Low (1972) reported that after 25 years of regular cultivation, the number of earthworms were only 11-16% of those in old grassland. An important explanation for the difference in soil food web under grassland and arable land is the availability in resources (e.g. total soil carbon and living roots). In addition to food supply, the mechanical damage and predation after cultivation play an important role, especially for meso- and macrofauna (Wardle, 1995). The difference in soil food web under grassland and arable land, influences the deliverance of ecosystem services supplied by the soil biota. Particularly the absence of earthworms in arable land has its impact on the services of soil structure maintenance and water regulation.

For a ley-arable crop rotation the following questions arise: How are the soil biota and its services restored in a grass ley after arable cropping, compared to a permanent grassland? How are these services, after restoration in the ley phase, conserved into the arable phase?

Concerning the recovery of microflora after tillage, Buckley and Schmidt (2001) found that the soil microbial community structure of an old arable field, 7 years after cultivation had been abandoned, still remained more similar to nearby cultivated sites than to fields which had never been cultivated. Similarly, Steenwerth *et al.* (2002) showed distinct differences in Phospholipid ester-linked fatty acid (PLFA) profiles of old permanent pastures compared to

profiles of fallow grasslands. They suggested that the soil environment and the associated microbial community may take decades to recover from cultivation effects. For nematodes, Villenave *et al.* (2001) determined that full restoration was not achieved within 10 years of fallow. Wasilewska (1994) showed that nematode taxa known to be colonizers or r-strategists dominated in younger meadows while persisters or K-strategists taxa dominated in older meadows. Yeates *et al.* (1998b) found that earthworm biomass increased after 5 years perennial pasture on sites formerly under arable cropping but not reached the level of permanent pastures. These data suggest that when cultivation is stopped and a grass fallow or grass ley is established changes in the soil biota composition takes place but restoration to the level of permanent grassland takes years.

Less information is available on the effect of ploughing a ley for arable land. Hatch *et al.* (2002) showed that the SIR and BIOLOG profiles of a ley resembled already the first year after cultivation those from arable land. For nematodes, Sohlenius and Sandor (1989) measured that it will take longer than one year before a ploughed ley resembles a continuous arable land. Concerning the functioning, Anderson and Domsch (1990) showed that the soil microbial biomass in a crop rotation had a more efficient respiration than from the microbial biomass in continuous cropping. This would suggest that, a ley-arable crop rotation could improve the ecosystem services of soil biota above continuous cropping.

In conclusion, results show that it takes years to restore the soil food web and its services in a grass ley to the level of permanent pasture. When the plant-soil cycle in a permanent pasture is running smoothly, ploughing up a permanent pasture for ley-farming should be avoided. A ley-arable crop rotation could benefit from ecosystem services of soil biota above continuous cropping. When a ley-arable crop rotation is practised, the length of the ley phase should be minimized. This, in order to reduce the pressure on permanent grassland on farm level and to overcome that lack of soil structure maintenance and water regulation by soil biota in the ley phase is decreasing the production. Since the number of earthworms is low at the start of the ley and restoration of the earthworms takes years, the services of soil structure maintenance and water regulation lag behind. In a young ley, this could possibly create difficulties in keeping the perennial cycle of plant-soil interactions running after the effects of soil cultivation on soil structure and water regulation are faded away. To stimulate these services earthworms could possibly be stimulated by sowing clover (Paragraph 5.1).

## Conclusions

For developing and optimising sustainable grassland systems, insight is needed into the mechanisms by which soil biota are influenced by management and what these mean for the functioning of the plant-soil system. The causal relations between grassland management, soil food web and its ecosystem services can be clarified in a cyclic conceptual framework with plant/roots, soil biota (root biota, decomposers and ecosystem engineers) and soil chemical properties (chemical and physical). The challenge for sustainable grassland management is to let this cycle function optimally with a minimum of external inputs. The basis of this cycle is a productive grassland with a good litter quantity and quality and a good functioning root system. It is assumed that the basal soil food web for sustainable agricultural grassland, is a bacterial-based food web taking care of a fast nutrient cycling process and a high density of earthworms taking care of, amongst others, the maintenance of soil structure and water regulation.

The introduction of white clover in a grass sward reduces the root density but due to the better litter quality, the differences in microflora between grass and grass-clover mixtures are variable. However, the biomass of earthworms seems to increase which has, together with other soil biota, a positive impact on the ecosystem service of water regulation. Herewith the introduction of white clover can be a tool to improve the cycle of plant-soil interactions.

For ley-farming, it takes years to restore the soil food web and its services in a grass ley to the level of permanent pasture. Ploughing up permanent pastures for ley-farming means a loss of soil biota and its services. A ley-arable crop rotation could benefit from ecosystem services of soil biota above continuous cropping. When a ley-arable crop rotation is practised, the ley phase should be only two to three years. This, in order to minimize the pressure on permanent grassland on farm level and to overcome that lack of soil structure maintenance and water regulation by soil biota in the ley phase is decreasing the production. To stimulate earthworms and their ecosystem services in the ley phase, a grass-clover mixture could be sown.

In the light of the plant-soil cycle, results show that use of clover is a sustainable measure but the introduction of ley-arable farming on a dairy farm should not be practised at the cost of permanent grasslands with its soil biota and its ecosystem services.

## References

- Anderson T.H. and Domsch K.H. (1990) Application of eco-physiological quotients ( $qCO_2$  and  $qD$ ) on microbial biomass from soils of different cropping histories. *Soil Biology and Biochemistry*, 22, 251-255.
- Baars T. (2002) Reconciling scientific approaches for organic farming research. Part II. Effects of manure types and white clover cultivars on the productivity of grass-clover mixtures grown on a humid sandy soil. PhD-thesis Wageningen University, 346 pp.
- Bardgett R.D. (2005) *The Biology of Soil: A community and ecosystem approach*. Oxford University Press, New York, 242 pp.
- Bardgett R.D. (1996) Potential effects on the soil mycoflora of changes in the agricultural policy for upland grasslands. In: J.C. Frankland, N. Magan and G.M. Gadd (eds) *Fungi and Environmental Changes. British Mycological Society Symposium of Cambridge* University Press, pp. 163-183.
- Bardgett R.D. and Wardle D.A. (2003) Herbivore-mediated linkages between aboveground and belowground communities. *Ecology*, 84(9), 2258-2268.
- Bardgett R. D., Cook R., Yeates, G. W. and Denton C. S. (1999a) The influence of nematodes on below-ground processes in grassland ecosystems. *Plant and Soil*, 212, 23-33.
- Bardgett R.D., Mawdsley J.L., Edwards S., Hobbs P.J., Rodwell J.S. and Davies W.J. (1999b) Plant species and nitrogen effect on soil biological properties of temperate upland grasslands. *Functional Ecology*, 13, 650-660.
- Beare M.H., Coleman D.C., Crossley Jr. D.A., Hendrix P.F. and Odum E.P. (1995) A hierarchical approach to evaluating the significance of soil biodiversity to biogeochemical cycling. *Plant Soil*, 170, 5-22.
- Beare M.H. et al (1990) A substrate-induced respiration (SIR) method for measurement fungal, bacterial and total microbial biomass on plant residues. *Agriculture, Ecosystems and Environment*, 34, 65-73
- Bloem J., Schouten A.J., Sørensen S.J., Rutgers M., van der Werf, A. and Breure A.M. (2006) Monitoring and evaluating soil quality. In: J. Bloem, A. Benedetti and D.W. Hopkins (eds) *Microbiological Methods for Assessing Soil Quality*. CABI, Wallingford, UK, pp. 23-49.
- Bouché M.B. and Al-Addan F. (1997) Earthworms, water infiltration and soil stability: some new assessment. *Soil Biology and Biochemistry*, 29, 441-452.
- Brown G.G. (1995) How do earthworms affect microfloral and faunal community diversity? *Plant and Soil*, 170, 209-231.
- Buckley D.H. and Smidt T.M. (2001) The structure of microbial communities in soil and the lasting impact of cultivation. *Microbial Ecology*, 42, 11-21.
- Brussaard L. (1998) Soil fauna, functional groups and ecosystem processes. *Applied soil ecology*, 9, 123-135.
- Brussaard L., Behan-Pelletier V.M., Bignell D.E., Brown V.K., Didden W.A.M., Folgarait P.J., Fragoso C., Freckman D.W., Gupta V.V.S.R., Hattori T., Hawksorth D.L., Klopatek C., Lavelle P., Walloch D., Rusek J., Söderström B., Tiedje J.M. and Virginia R.A. (1997) Biodiversity and ecosystem functioning in soil. *Ambio*, 26(8), 563-570.

- Clements R.O., Murray P.J. and Sturdy R.G. (1991) The impact of 20 years' absence of earthworms and three levels of N fertilizers on a grassland environment. *Agriculture Ecosystems and Environment*, 36, 75-85.
- Cole L., Bradford M.A., Shaw P.J.A. and Bardgett R.D. (2006) The abundance, richness and functional role of soil meso- and macrofauna in temperate grassland- A case study. *Applied Soil Ecology*, 33, 186-198.
- Deinum B. (1981) Root mass of grass swards in different grazing systems. *Netherlands Journal of Agricultural Science*, 33, 377-384.
- Denton C.S., Bardgett R.D., Cook R. and Hobbs P.J. (1999) Low amounts of root herbivory positively influence the rhizosphere microbial community in a temperate grassland soil. *Soil Biology and Biochemistry*, 31, 155-165.
- De Ruiter P.C., Van Veen J.A., Moore J.C., Brussaard L. and Hunt H.W. (1993) Simulation of nitrogen mineralization in soil food webs. *Plant and Soil*, 157, 263-273.
- De Vries F.T., Bloem J., Van Eekeren N., Brussaard L. and Hoffland E. (2007) Fungal biomass in pastures increase with age and reduced N input. *Soil Biology and Biochemistry* in press.
- De Vries F.T., Hoffland E., Van Eekeren N., Brussaard L. and Bloem J. (2006) Fungal/bacterial ratios in grasslands with contrasting nitrogen management. *Soil Biology and Biochemistry*, 38, 2092-2013.
- Edwards W.M., Shipitalo M.J., Traina S.J., Edwards C.A. and Owen L.B. (1992) Role of *Lumbricus terrestris* (L.) burrows on the quality of infiltrating water. *Soil Biology and Biochemistry*, 21, 1555-1561.
- Evans P.S. (1977) Comparative root morphology of some pasture grasses and clovers. *N.Z. Journal Agricultural Research*, 20, 331-335.
- Fromm H., Winter K., Filser J., Hantschel R. and Beese F. (1993) The influence of soil type and cultivation system on the spatial distribution of the soil fauna and micro organisms and their interactions. *Geoderma*, 60, 109-118.
- Griffiths B.S. (1989) The role of bacterial feeding nematodes and protozoa in rhizosphere nutrient cycling. *Aspects of Applied Biology*, 22, 141-145.
- Griffiths B.S., Welschen R., van Arendonk J.J.C.M. and Lambers H. (1992) The effect of nitrate-nitrogen supply on bacteria and bacterial-feeding fauna in the rhizosphere of different grass species. *Oecologia*, 91, 253-259.
- Grime J.P., Mackey, J.M., Hillier, S.H. and Read, D.J. (1987) Floristic diversity in a model system using experimental microcosmos. *Nature*, 328, 420-422.
- Hamilton E.W. and Frank D.A. (2001) Can plants stimulate soil microbes and their own nutrient supply? Evidence from a grazing tolerant grass. *Ecology*, 82(9), 2397-2402.
- Haria A.H. et al (1998) Impact of the New Zealand flatworm (*Artoposthia triangulate*) on soil structure and hydrology in the UK. *Science of the Total Environment*, 215, 259-265.
- Hatch D., Easson L., Goulding K., Haygarth P., Shepherd M. and Watson C. (2002) Grassland resowing and grass-arable rotations in the United Kingdom: agricultural and environmental issues. In: J.G. Conijn, G.L. Velthof and F. Taube (eds) *Grassland resowing and grass-arable crop rotations. International workshop on Agricultural and Environmental Issues*, Wageningen, The Netherlands, pp. 93-104
- Hoogerkamp M., Rogaar H. and Eysackers H.J.P. (1983) Effects of earthworms on grassland on recently reclaimed polder soils in the Netherlands. In: Satchell, J.E. (eds) *Earthworm Ecology: from Darwin to vermiculture*. Chapman and Hall, London, pp. 85-105.
- Ingham R.E., Trfymow J.A., Ingham E.R. and Coleman D.C. (1985) Interactions of bacteria, fungi and their nematode grazers: effects on nutrient cycling and plant growth. *Ecological Monographs*, 55, 119-140.
- Juma N. G. and Mishra C. C. (1988) Effect of an annual and a perennial crop on trophic group dynamics of nematodes. *Canadian Journal of Soil Science*, 68, 101-109.
- Lamandé M., Hallaire V., Curmi P., Pérès G. and Cluzeau D. (2003) Changes of pore morphology, infiltration and earthworm community in a loamy soil under different agricultural managements. *Catena*, 54, 637-649.
- Logsdon S.D. and Linden R.D. (1992) Interactions of earthworms with soil physical conditions influencing plant growth. *Soil Science*, 154(4), 330-337.
- Low A.J. (1972) The effect of cultivation on the structure and other physical characteristics of grassland and arable soils (1945-1970). *Journal of Soil Science*, 363-380.
- Mackay A.D., Syers J.K., Springett J.A. and Gregg P.E.H. (1982) Plant availability of phosphorus in superphosphate and a phosphate rock as influenced by earthworms. *Soil Biology and Biochemistry*, 14, 281-287.
- Mäder P., Fliessbach A., Dubois D., Gunst L., Fried P. and Niggli U. (2002) Soil fertility and biodiversity in Organic farming. *Science*, 296, 1694-1697.
- Mawdsley J.L. and Bardgett R.D. (1997) Continuous defoliation of perennial ryegrass (*Lolium perenne*) and white clover (*Trifolium repens*) and associated changes in the microbial population of a upland soil. *Biology and Fertility of Soils*, 24, 52-58
- Mulder C. (2006) Driving force from soil invertebrates to ecosystem functioning: the allometric perspective. *Naturwissenschaften*, 93, 467-479.
- Murray P.J. and Clements R.O. (1998) Transfer of nitrogen between clover and wheat: Effect of root herbivory. *European Journal of Soil Biology*, 34, 25-30.



- Murray P.J. and Hatch D.J. (1994) *Sitona* weevils (Coleoptera, Curculionidae) as agents for rapid transfer of nitrogen from white clover (*Trifolium repens* L) to Perennial Ryegrass (*Lolium perenne* L). *Annals of Applied Biology*, 125(1), 29-33.
- Murray P.J., Cook R., Currie A.F., Dawson L.A., Gange A.C., Grayston S.G. and Treonis A.M. (2006) Interactions between fertilizer addition, plants and the soil environment: Implications for soil faunal structure and diversity. *Applied Soil Ecology*, 33, 199-207.
- Mytton L.R., Cresswell A. and Colbourn, P. (1993) Improvement in soil structure associated with white clover. *Grass and Forage Science*, 48, 84-90.
- Neergaard A.D, Hauggaard-Nielsen H., Jensen L.S. and Magid J. (2002) Decomposition of white clover (*Trifolium repens*) and ryegrass (*Lolium perenne*) components: C and N dynamics simulated with the DAISY soil organic matter submodel. *European Journal of Agronomy*, 16, 43-55.
- Nevens F. and Reheul D. (2002) The nitrogen- and non-nitrogen-contribution effect of ploughed grass leys on the following arable forage crops: determination and optimum use. *European Journal of Agronomy*, 16, 57-74.
- Salomon et al (2004) Effects of plant diversity on Collembola in an experimental grassland ecosystem. *Oikos*, 106, 51-60
- Schortemeyer M., Santruckova H. and Sadowsky M.J. (1997) Relationship between root length density and soil microorganisms in the rhizospheres of white clover and perennial ryegrass. *Communications in Soil Science and Plant Analysis*, 28, 1675-1682.
- Schouten T., Breure A.M., Mulder C. and Rutgers M. (2004) Nematode diversity in Dutch soils, from Rio a biological indicator for soil quality. *Nematology Monographs and Perspectives*, 2, 469-482
- Schouten A.J., Bloem J., Didden W., Jagers op Akkerhuis G., Keidel H. and Rutgers M. (2002) *Bodembiologische Indicator 1999. Ecologische kwaliteit van graslanden op zandgrond.*, RIVM Report 607604003.
- Schouten A.J., Bloem J., Breure A.M., Didden W.A.M., van Esbroek M., de Ruiter P.C., Rutgers M., Siepel h. and Velvis H. (2000) *Pilot project Bodembiologische Indicator voor Life Support Functies van de bodem.* RIVM rapport 607604001.
- Sears, P.D. 1950. Soil fertility and pasture growth. *Journal of the British Grassland Society* 5: 267-280.
- Smith S.E. and Read D.J. (1997) *Mycorrhizal symbiosis*. Second edition. The University press, Cambridge.
- Sohlenius B. and Sandor A. (1989) Ploughing of a perennial grass ley – effect on the nematode fauna. *Pedobiologia*, 33, 199-210.
- Steenwerth K. L., Jackson L. E. Cakderón F. J., Stromberg M. R. and Scow, K. M. (2002) Soil microbial community composition and land use history in cultivated and grassland ecosystems of coastal California. *Soil Biology and Biochemistry*, 34, 1599-1611.
- Syers J.K. and Springett J.A. (1983) Earthworm ecology in grassland soils. In: *Earthworm ecology: from Darwin to vermiculture*. Satchell, J.E (eds) Chapman and Hall. London: pp 67-105.
- Tisdall J.M. and Oades J.M. (1979) Stabilisation of soil aggregates by root systems of ryegrass. *Australian journal of soil research*, 17, 429-441.
- Van der Heijden M., Klironomos J.N., Ursicvan M., Moutoglis P., Streitwolf-Engel R, Boller T., Wiemken A. and Sanders I.R. (1998) Mycorrhizal fungal diversity determines plant biodiversity, ecosystem variability and productivity. *Nature* 396, 69-72.
- Van Eekeren N., Smeding F.W., De Vries F.T. and Bloem J. (2005) Analysis of the soil food web structure under grass and grass-clover. In: Wachendorf, M., Helgadóttir, A., Parente, G. (eds) *Sward dynamic, N-flows and forage utilisation in legume-based systems*, Proceedings of the 2<sup>nd</sup> COST 852 workshop in Grado, pp. 37-40.
- Villenave C., Bongers T., Ekschmitt K., Djigal D. and Chotte J. L. (2001) Changes in nematode communities following cultivation of soils after fallow periods of different length. *Applied Soil Ecology*, 17, 43-52.
- Wardle D.A. (2002) *Communities and Ecosystems: Linking the Aboveground and Belowground Components. Monographs in Population Biology 34.* Princeton University Pres, NJ, 392 pp.
- Wardle D.A. and Bardgett R.D., Klironomos J.N., Setälä H., van der Putten W.H. and Wall D.H. (2004) Ecological Linkages between aboveground and belowground biota. *Science*, 304, 1629-1633.
- Wardle D.A. (1995) Impact of disturbance on detritus food-webs in agro-ecosystems of contrasting tillage and weed management practices. *Advances in Ecological Research*, 26, 105-185.
- Wasilewska L. (1995) Differences in the development of soil nematode communities in single- and multi-species grass experimental treatments. *Applied Soil Biology*, 2, 53-64.
- Wasilewska L. (1994) The effect of age of meadows on succession and diversity in soil nematode communities. *Pedobiologia*, 38, 1-11.
- Wasilewska L. (1979) The structure and function of soil nematode communities in natural ecosystems and agrocenoses. *Polish Ecological Studies*, 5, 97-145.
- Whipps J.M. (1990) Carbon economy. In: Lynch J.M. (eds) *The rhizosphere*, 59-97.

- Yeates G.W., Saggat S., Denton C.S. and Mercer C.F. (1998a) Impact of the clover cyst nematode (*Heterodera trifolii*) infection on soil microbial activity in the rhizosphere of white clover (*Trifolium repens*)-a pulse labelling experiment. *Nematologica*, 44, 81-90.
- Yeates G.W., Shepherd T. G. and Francis G. S. (1998b) Contrasting response to cropping of populations of earthworms and predacious nematodes in four soils. *Soil Tillage Research* 48, 255-264.
- Yeates G.W., Bardgett R.D., Cook R., Hobbs P.J., Bowling P.J. and Potter J.F. (1997) Faunal and microbial diversity in three Welsh grassland soils under conventional and organic regimes. *Journal of Applied Ecology*, 34, 453-470.
- Younie D. and Hermansen J. (2000) The role of grassland in organic livestock farming. In: Sørensen, *et al.* (eds), Grassland Farming-Balancing environmental and economic demands. *Proceedings of the 18 th General Meeting of the European Grassland Federation*, Aalborg, Denmark, 22-25 may 2000, 493-509.

# Grassland microbial community shifts in relation to management and elevated CO<sub>2</sub>

Denef K.<sup>1</sup>, Wilasini M.<sup>1</sup>, Bubenheim H.<sup>2</sup>, Lenhart K.<sup>2</sup>, Müller C.<sup>2</sup>, Van Cleemput<sup>1</sup>, O. and Boeckx P.<sup>1</sup>

<sup>1</sup>*Ghent University, FBW, Coupure Links 653, 9000 Gent, Belgium*

<sup>2</sup>*Justus-Liebig-University Giessen, Heinrich-Buff-Ring 26-32, 35392 Giessen, Germany*

## Abstract

With the aim to identify the microbial groups most sensitive to grassland management and increased greenhouse gas concentrations, we analysed <sup>13</sup>C signatures in microbial biomarker phospholipid fatty acids (PLFA) from two <sup>13</sup>CO<sub>2</sub> pulse-labelling experiments: one was performed in managed grasslands in Merelbeke (Belgium) with three N-fertilization levels and two mowing frequencies. The second took place in the GiFACE (Giessen Free-Air Carbon dioxide Enrichment) grasslands in Giessen (Germany) with ambient and elevated CO<sub>2</sub> treatments. An increase in N fertilization caused a decrease in the proportion of new (pulse-label derived) PLFA-C for the arbuscular mycorrhizal fungal (AMF) PFLA (16:1ω5), and an increase for the gram-positive bacterial PLFAs. Mowing frequency did not significantly affect the distribution of new PLFA-C among the biomarker PLFAs. At the GiFACE experiment, <sup>13</sup>C-PLFA measurements over time indicated a rapid transfer of plant-C to fungi and a much slower transfer to bacteria. Elevated CO<sub>2</sub> caused an increase in the proportion of new PLFA-C for the saprotrophic fungal biomarker 18:2ω6,9 and AMF biomarker 16:1ω5, but a decrease for the saprotrophic fungal biomarker 18:1ω9, suggesting enhanced rhizodeposit-C assimilation by selected fungal communities under elevated CO<sub>2</sub>.

Keywords: PLFA, soil microbial community, <sup>13</sup>CO<sub>2</sub> pulse-labelling, grassland, mowing, fertilizer, elevated CO<sub>2</sub> (FACE)

## Introduction

Soil microbial communities in grassland ecosystems can be highly responsive to management practices and climate change (e.g. Bardgett *et al.*, 1996; Drissner *et al.*, 2007). Shifts in microbial community structure as a result of land-use or climate change could have drastic effects on biogeochemical processes such as carbon and nutrient transformations, as these processes are differently regulated by different soil microbial communities. Increases in the abundance of bacteria relative to fungi in the soil microbial community are typically associated with an increase in rates of C and nutrient cycling (Wardle *et al.*, 2004). So far, contrasting results have been reported on the impacts of elevated CO<sub>2</sub> and grassland management practices on the composition, abundance and function of microorganisms. Microbial community composition is frequently assessed through in situ analyses of PLFAs. The combination of stable isotope probing of PLFAs (PLFA-SIP) and <sup>13</sup>C-PLFA analysis through gas chromatography – combustion – isotope ratio mass spectrometry (GC-C-IRMS) has made it possible to study the ‘metabolically-active’ microbial communities. The main objective of this study was to investigate which microbial communities are actively assimilating rhizosphere-C in grassland ecosystems and which communities are most sensitive in their activity to elevated CO<sub>2</sub>, N fertilization and mowing.

## Materials and methods

The GiFACE experiment is located on a grassland at the “Environmental Monitoring and Climate Impact Research Station Linden” near Giessen in Germany. The soil is a Fluvic Gleysol with a sandy clay loam texture. The vegetation was dominated by an *Arrhenatheretum elatioris* (Br.-Bl.) *Filipendula ulmaria* sub-community vegetation. In September 2005, a pulse-labelling was conducted on one site exposed to ‘ambient’ CO<sub>2</sub> concentrations (~370 ppm) and one exposed to ‘elevated’ CO<sub>2</sub> (~555 ppm). The pulse-labelling consisted of an automated 6 h supply of <sup>13</sup>CO<sub>2</sub> (99 atom%) to photosynthesizing grasses inside a plexiglass chamber. Within each chamber, soil samples were taken from the 0-7.5 cm depth prior to, 3 and 10 h after the start of pulse-labelling, as well as after 11 months. The managed grassland sites were located at the experimental research area of the Institute for Agricultural and Fisheries Research (ILVO) near Merelbeke in Belgium. The following mineral N fertilization and mowing combination treatments were selected, each with 4 replicates: (1) 0N, 3x (i.e. 0 kg N ha<sup>-1</sup> yr<sup>-1</sup> and 3 cuts yr<sup>-1</sup>); (2) 225N, 3x; (3) 225N, 5x; (4) 450N, 3x; (5) 450N, 5x. The vegetation was composed of *Lolium perenne* “Ritz”, *Lolium perenne* “Pandora”, *Phleum pratense* “Erecta”, *Festuca pratensis* “Merifest” and *Poa pratensis* “Balin”. After mowing, hay was removed on all sampling sites. In August 2006, a similar pulse-labelling experiment was performed on each plot. Soil samples were taken prior to and 24 h after the start of the pulse-labelling from 0-5, 5-10 and 10-20 cm depths. PLFAs were extracted from soil samples cfr. Bossio and Scow (1995) and analysed for <sup>13</sup>C by GC-C-IRMS. The proportion of new (i.e. pulse-label derived) PLFA-C was calculated for each individual PLFA. Carbon-13 enrichment was calculated by subtracting the pre-labelling from the post-labelling  $\delta^{13}\text{C}$  values of the individual biomarker PLFAs.

## Results and discussion

At the GiFACE experimental grasslands, a significant incorporation of <sup>13</sup>C was observed in the saprotrophic fungal (18:1 $\omega$ 9, 18:2 $\omega$ 6) and AMF (16:1 $\omega$ 5) biomarker PLFAs after 10 h, while remaining very low for the bacterial PLFAs (Figure 1). While <sup>13</sup>C enrichment in fungal PLFA significantly decreased after 11 months, in particular in the AMF fungal biomarker, <sup>13</sup>C enrichment in all fungal PLFAs remained large (Figure 1). After 11 months, significant amounts of <sup>13</sup>C were also found in bacterial PLFA.

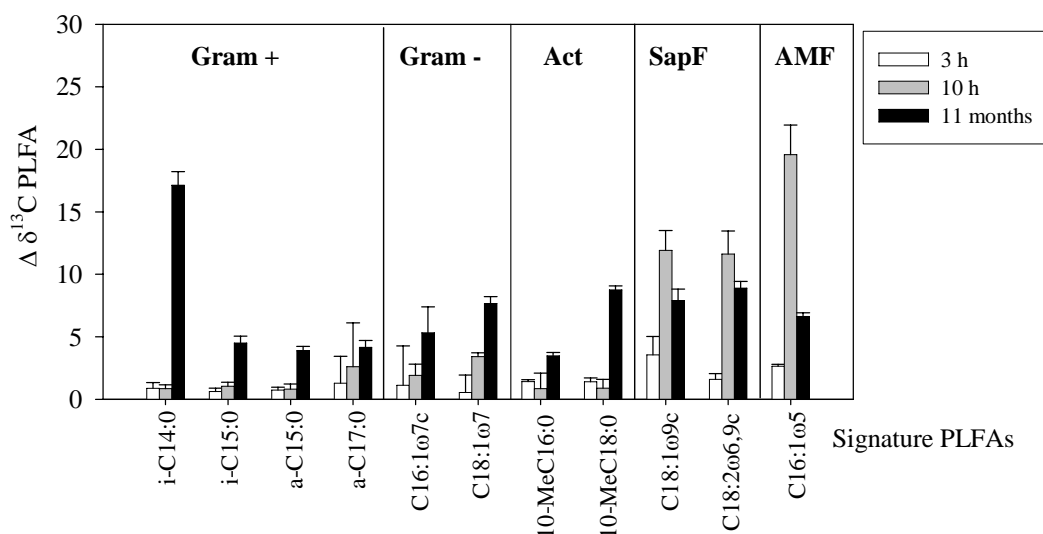

Figure 1:  $\delta^{13}\text{C}$  enrichment ( $\Delta\delta^{13}\text{C}$ ) of biomarker PLFAs at 3 h, 10 h and 11 months after the start of <sup>13</sup>CO<sub>2</sub> pulse-labelling at GiFACE. Gram - = gram-negative bacterial PLFAs; Gram + = gram-positive bacterial PLFAs; Act = actinomycete PLFAs; SapF = saprotrophic fungal PLFAs; AMF = arbuscular mycorrhizal fungal PLFAs.

Other pulse-labelling studies in grasslands have also reported a much faster incorporation of  $^{13}\text{C}$  into fungal compared to bacterial PLFA (e.g. Treonis *et al.*, 2004) suggesting that these populations are most rapidly assimilating rhizosphere-C in grassland ecosystems. The distribution of new (i.e., pulse-label derived) PLFA-C among the different biomarker PLFAs also greatly differed from that of total PLFA-C (Figure 2a,b), suggesting that a different subset of the microbial biomass, in this case the fungal community, was primarily responsible for assimilating new rhizodeposit-C. Fungal communities were therefore expected to be most sensitive in their activity to plant responses to management or elevated  $\text{CO}_2$ .

A greater proportion of PLFA-C was found in the saprotrophic fungal biomarker 18:2 $\omega$ 6 under elevated vs. ambient  $\text{CO}_2$  (Figure 2b). Stimulated fungal activities under elevated  $\text{CO}_2$  have been attributed to the greater substrate use efficiency of fungi in N-limited ecosystems (Klironomos *et al.*, 1996), such as the GiFACE grasslands. However, other studies were unable to detect shifts between bacterial and fungal communities or showed an increase in the proportion of gram-negative bacteria under elevated  $\text{CO}_2$  (e.g. Drissner *et al.*, 2007). These studies only examined total C distributions among PLFAs which do not provide information on the activity of microbial communities. Our pulse-labelling PLFA-SIP approach provided, for the first time, information on the response of metabolically-active microbial communities in situ to elevated  $\text{CO}_2$ . Under elevated  $\text{CO}_2$ , a greater proportion of new PLFA-C was found in the saprotrophic fungal 18:2 $\omega$ 6 and AMF 16:1 $\omega$ 5 biomarkers, while the opposite was observed for the saprotrophic fungal 18:1 $\omega$ 9 (Figure 2a). Since PLFA analysis does not allow the detection of individual microbial species, it is possible that different fungal species were differently affected by the elevated  $\text{CO}_2$ .

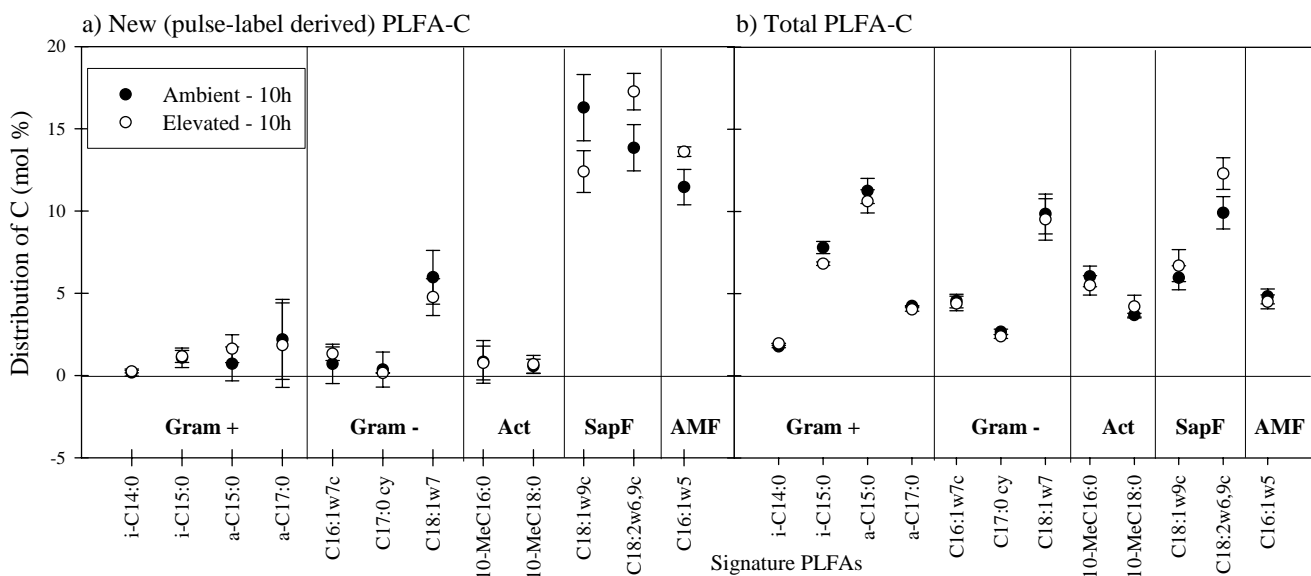

Figure 2: The proportional distribution (mol %) of new (pulse-label derived) PLFA-C (a) and total PLFA-C (b) among biomarker PLFAs in surface (0-7.5 cm) soil at GiFACE. Abbreviations cfr. Figure 1.

At the managed grassland sites in Merelbeke, the total mol% distributions of PLFA-C among biomarker PLFAs did not drastically differ among grassland fertilizer and mowing treatments (data not shown). In contrast, clear differences between the fertilizer treatments were found in the proportions of new PLFA-C (Figure 3a). Increased N fertilizer application significantly reduced the proportion of new PLFA-C in the AMF biomarker 16:1 $\omega$ 5, but did not affect the proportion of new PLFA-C in the saprotrophic biomarker PLFAs (Figure 3a). For the bacterial communities, the proportions of new PLFA-C were increased with N fertilization for the gram-positive bacterial communities, but not for the gram-negative bacterial communities. Shifts in grassland microbial community structure from one favouring fungi to one favouring

bacteria with increasing fertilization have been documented by others (e.g., Bardgett *et al.*, 1996) and attributed to the direct inhibitory effect of fertilizer on saprotrophic and mycorrhizal fungi. In this study, the negative effects of fertilization on fungi were only observed in the AMF community. Stimulated microbial activity due to increases in plant productivity and root-C inputs with N fertilization could have outweighed the negative effects of mineral N additions on the saprotrophic fungi.

Mowing has received less attention with regard to its effect on soil microbial community composition. Biomass removal could result in an increase in root respiration and exudation, which could stimulate microbial growth (Bardgett *et al.*, 1996). Bardgett *et al.* (1996) showed that biomass removal by grazing favoured the presence of fungi, but they attributed this to the input of faeces from the grazing animals. Our data suggests that an increase in mowing frequency from 3 cuts yr<sup>-1</sup> to 5 cuts yr<sup>-1</sup> did not significantly alter the structure of the metabolically-active microbial community (Figure 3b).

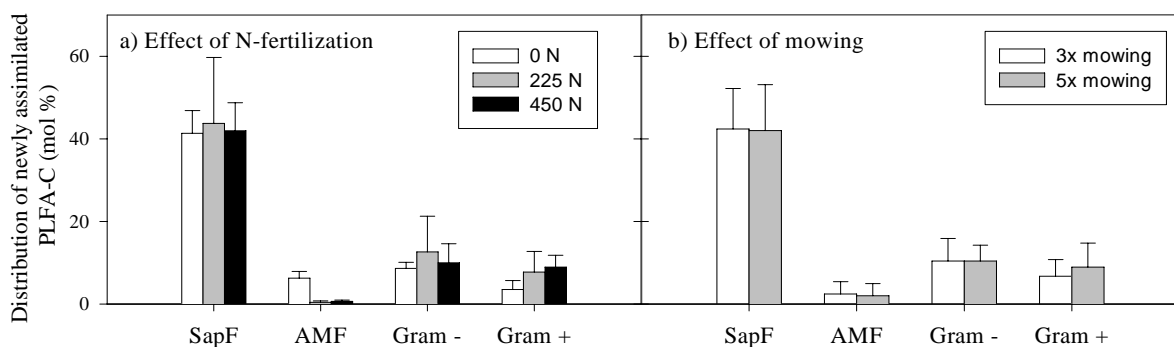

Figure 3: The proportional distribution (mol %) of new (pulse-label derived) PLFA-C among biomarker PLFAs in surface (0-5 cm) soils at Merelbeke. The average effect of mowing (b) was shown for the 225N and 450N fertilizer treatments. Abbreviations cfr. Figure 1.

## Conclusion

The use of PLFA-SIP at GiFACE demonstrated a stimulated activity of selected fungal communities under elevated CO<sub>2</sub>. At Merelbeke, PLFA-SIP provided evidence to support the view that mycorrhizal fungi are more sensitive to the application of mineral fertilizer than saprotrophic fungi. However, responses of soil microbial communities to grassland management are likely to be strongly regulated by long-term changes in plant productivity.

## References

- Bardgett, R.D., P.J. Hobbs, and A. Fröstegard (1996) Changes in soil fungal: bacterial biomass ratios following reductions in the intensity of management of an upland grassland. *Biology and Fertility of Soils*, 22, 261-264.
- Bossio, D.A., and K.M. Scow (1995) Impact of carbon and flooding on the metabolic diversity of microbial communities in soils. *Applied and Environmental Microbiology*, 61, 4043-4050.
- Drissner, D., H. Blum, D. Tschirko, and E. Kandeler (2007) Nine years of enriched CO<sub>2</sub> changes the function and structural diversity of soil microorganisms in a grassland. *European Journal of Soil Science*, 58, 260-269.
- Klironomos, J.N., M.C. Rillig, and M.F. Allen (1996) Below-ground microbial and microfaunal responses to *Artemisia tridentata* grown under elevated atmospheric CO<sub>2</sub>. *Functional Ecology*, 10, 527-534.
- Treonis, A.M., N.J. Ostle, A.W. Stott, R. Primrose, S.J. Grayston, and P. Ineson (2004) Identification of groups of metabolically-active rhizosphere microorganisms by sTable isotope probing of PLFAs. *Soil Biology and Biochemistry*, 36, 533-537.
- Wardle, D.A., R.D. Bardgett, J.N. Klironomos, H. Setälä, W.H. van der Putten, D.H. Wall (2004) Ecological linkages between aboveground and belowground biota. *Science* 304, 1629-1633.
- Williams, M.A., D.D. Myrold, , and P.J. Bottomley (2006) Carbon flow from <sup>13</sup>C-labeled straw and root residues into the phospholipid fatty acid of a soil microbial community under field conditions. *Soil Biology and Biochemistry*, 38, 759-768.

# The effects of a moderate long-term Free Air CO<sub>2</sub> Enrichment (FACE) on soil aggregation and soil organic carbon content of a temperate grassland soil

Lenhart K.<sup>1</sup>, Kammann C.<sup>1</sup>, Argüello-Montserrat E.<sup>1</sup>, Six J.<sup>2</sup>, Boeckx P.<sup>3</sup>, Jäger H.-J.<sup>1</sup> and Müller C.<sup>1</sup>

<sup>1</sup>Dept. of Plant Ecology, University of Giessen, 35392 Giessen, Germany

<sup>2</sup>Dept. of Plant Sciences, Univ. of California, Davis, CA 956162

<sup>3</sup>Laboratory of Applied Physical Chemistry –ISOFYS, Ghent University, Belgium

## Abstract

Plants play a major role in the global carbon (C) cycle via uptake of atmospheric CO<sub>2</sub> and subsequent transfer of C into the soil. We examined the effects of 6 years of elevated atmospheric CO<sub>2</sub> concentrations on soil aggregation and soil organic carbon (C<sub>org</sub>) in the Gießen-FACE study on temperate grassland soil. During the experimental period a C<sub>org</sub> loss in several soil aggregate fractions (i.e. large and small macroaggregates, microaggregates and silt and clay) was observed, both under elevated and ambient atmospheric CO<sub>2</sub> conditions. The average decrease of C<sub>org</sub> in the top 15 cm between 1998 and 2004 was 0.88 kg C m<sup>-2</sup> for the ambient plots and 1.22 kg C m<sup>-2</sup> for the elevated CO<sub>2</sub> plots. An increase of ecosystem respiration (R<sub>eco</sub>) during the investigation period as a result of increased labile C<sub>org</sub> availability and concomitant enhanced decomposition may explain these observations.

Keywords: elevated CO<sub>2</sub> (FACE), soil C, aggregates, temperate grassland

## Introduction

In light of the rising atmospheric CO<sub>2</sub> concentrations and its adverse effects on the global climate, suitable mitigation strategies are urgently needed. One of the hopes is that soils may sequester some of the additional C. Enhanced soil C sequestration would, in the long term, lead to increasing C<sub>org</sub> concentrations in the soil. However, this prediction is in contrast to the observed C loss over the last 30 years in most ecosystems in the United Kingdom (Bellamy *et al.* 2005). In order to better predict the long-term effects of elevated CO<sub>2</sub> on C sequestration we need to improve our understanding of the processes controlling C sequestration and how they are affected under elevated CO<sub>2</sub>. Soil aggregation plays an important role in the long-term storage of C in the soil (van Veen and Paul 1981; Jastrow 1996; Six *et al.* 2002). Aggregation of soil is influenced by elevated CO<sub>2</sub> (Six *et al.* 2001), plant species (Eviner and Chapin III 2002), fertilisation (Latif *et al.* 1992), and tillage intensity. In this paper we present results on soil aggregation and soil carbon content of a semi-natural, extensively managed grassland ecosystem under ambient and six years of elevated CO<sub>2</sub> concentrations.

## Materials and methods

Data were obtained from the Environmental Monitoring and Climatic Impact Research Station Linden at 50°32'N and 8°41.3'E located near Giessen, Germany, on a permanent semi-natural grassland with fertilization of 40 kg N ha<sup>-1</sup> yr<sup>-1</sup>. The soil is a Fluvisol with a texture of sandy clay loam over a clay layer (FAO classification). Since 1993 the average annual air temperature and precipitation were 9.3°C and 586 mm. We observed C<sub>org</sub> content and soil aggregation on three ring pairs, each consisting of one control plot (A) at ambient atmospheric CO<sub>2</sub> concentration (≈367 ppm) and one FACE plot E, at +20% above ambient

CO<sub>2</sub> concentration ( $\approx 440$  ppm) (Jäger *et al.* 2003). Soil samples collected between 1997 and 2003 were taken from 0-5, 5-10 and 10-15 cm depth as 14 sub samples per ring and homogenised to one composite sample. In 2004 three soil samples per plot were taken in 0-7.5 and 7.5-15 cm depth (soil sampler: Ejkelkamp, Giesbeek, The Netherlands). Soil samples were air-dried and all visible roots were removed manually with tweezers. Soil samples from 1998 and 2004 were separated in four aggregate size classes by wet sieving on a 8 mm sieved air dried 100g sub sample using the method described by Six *et al.* (1998). A series of three sieves (2000  $\mu\text{m}$ , 250  $\mu\text{m}$  and 53  $\mu\text{m}$ ) was used to obtain the four aggregate size classes:  $>2000$   $\mu\text{m}$  (large macroaggregates; LM), 250-2000  $\mu\text{m}$  (small macroaggregates; SM), 53-250  $\mu\text{m}$  (microaggregates; Mic) and  $<53$   $\mu\text{m}$  (silt and clay; SC). For the C content analysis of the samples collected in June 2004 the three fractionated sub samples per plot were mixed up to one composite sample. For the samples taken in 1998 all values were calculated as weighted averages for 0-7.5 and 7.5-15 cm. To remove any soil carbonates the soil samples were fumigated with hydrochloric acid (12M) for 6h (Harris *et al.* 2001). The C content of the soil samples was measured at the UC Davis Stable Isotope Facility using a CN elemental analyser. Data are presented separately for each ring as averages  $\pm$  standard deviations, except for the root biomass values where the standard error is given.

## Results and discussion

The average fraction of large macroaggregates in 0-7.5 cm depth was  $58.2 \pm 7.1\%$  and  $58.1 \pm 6.2\%$  in 1998 for the plots A1-A3 and E1-E3, respectively. Between 1998 and 2004, this fraction decreased by 17.5% and 13.6% in A and E plots, respectively, for the benefit of the SM (14.5 and 12.8%) and the Mic fraction (4.6 and 2.3%) (Figure 1). In the deeper soil layer (7.5-15 cm) we observed both, a decrease and an increase of the LM fraction (Figure 1). A conspicuous decrease of the LM fraction occurred in the plots A1 (-18.2%) and A2 (-17.3%), whereas the LM content of E1 and E2 remained nearly unaltered.

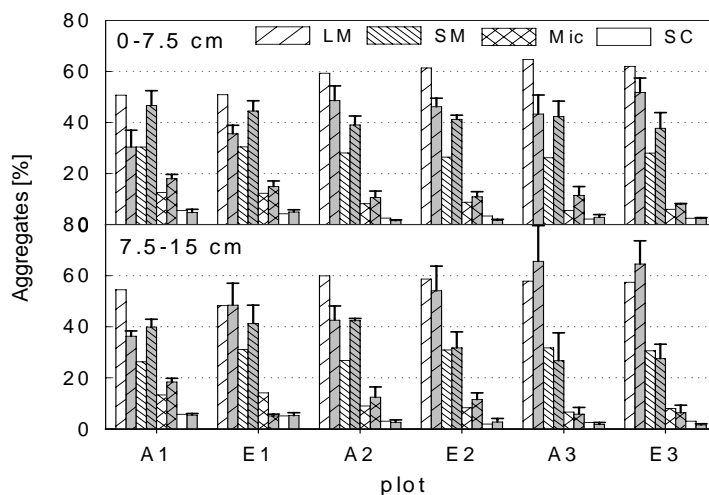

Figure 1. Distribution of soil aggregates in the years 1998 (white) and 2004 (grey) in 0-7.5 and 7.5-15 cm depth of a temperate grassland soil under ambient (A) and elevated (E) CO<sub>2</sub> (data are presented as averages  $\pm$  standard deviation).

In ring pair three the LM fraction increased about 7.7% (A3) and 7.2% (E3). Therefore, factors other than CO<sub>2</sub> must have been responsible for the observed structural change between 1998 and 2004. Also no correlations

were found between the structural change and the abiotic factors temperature (soil and air temperature), moisture (volumetric water content, rainfall, ground water Table), and the amount of N-fertilizer.

In a parallel study at the GiFACE sites, Janze (2006) observed a decline of plant biodiversity between 1998 and 2005 under both CO<sub>2</sub> treatments. The decline was lower under elevated CO<sub>2</sub> (from 16.2 to 11.2 species) than under ambient CO<sub>2</sub> conditions (from 18.2 to 10.3 species); this decline was also reflected by a decrease of root biomass from  $639 \pm 39$  g m<sup>-2</sup> to  $325 \pm 12$  g m<sup>-2</sup> (A plots) and  $595 \pm 79$  g m<sup>-2</sup> to  $407 \pm 12$  g m<sup>-2</sup> (E plots) in the Ah-horizon (0-12 cm). A CO<sub>2</sub>-induced species shift effect has also been observed in calcareous grassland



(Leadley *et al.* 1999). However, annual aboveground biomass yield did not decrease during the investigation period (Kammann *et al.* 2005), but was on average 0.716 (E1-E3) and 0.690 kg m<sup>-2</sup> (A1-A3) for the years 1998 to 2004, indicating only a minor CO<sub>2</sub>-induced aboveground biomass increase.

Soil aggregates are stabilized by various binding agents; the macroaggregates are stabilized by roots and fungal hyphae, whereas the stabilization of microaggregates depends on persistent organic materials, crystalline oxides and aluminosilicates (Tisdall and Oades 1982). Consequently, the shift in plant species composition together with a concomitant decrease of root biomass may have adversely affected soil aggregation and possibly led to a break up of LM. A dependency between aggregate stability and plant species is well known (Eviner and Chapin III 2002). Also an increase of soil aggregation under elevated CO<sub>2</sub> in the Swiss-FACE study was positively correlated to root biomass (Six *et al.* 2001). Moreover, the plant species richness influences the soil microbial activity and composition (Chung *et al.* 2007), which in turn affects the aggregation of soil. In our study, a likely positive effect of CO<sub>2</sub> on soil aggregation was counterbalanced by a general large soil aggregation change.

While the C<sub>org</sub> content of the macroaggregate fractions decreased or remained unaltered, a small increase was observed in the Mic fraction (Figure 2). In the LM and SM fractions C<sub>org</sub> decreased on average for all plots (A1-E3) by 7.0 g C kg<sup>-1</sup> agg and 3.7 g C kg<sup>-1</sup> agg, respectively. Together with the change in soil aggregate structure this led to a mean decrease in LM associated C<sub>org</sub> of 1.09 kg C m<sup>-2</sup> for the uppermost 15 cm, whereas the total amount of C<sub>org</sub> stored in the SM and Mic fractions increased about 0.34 and 0.02 kg C m<sup>-2</sup>, respectively. The total C<sub>org</sub> content decreased by about 1.22 and 0.88 kg C m<sup>-2</sup> for E and A, respectively. Thus the soil lost within 6 years on average 2.6% C<sub>org</sub> per year in the top 15 cm, which corresponds to the rate of C loss in soils with carbon contents higher than 100 g kg<sup>-1</sup> analyzed by Bellamy *et al.* (2005). The redistribution of C<sub>org</sub> from the largest aggregate size class (LM) into the smaller aggregate size classes (SM and Mic) together with the redistribution of the

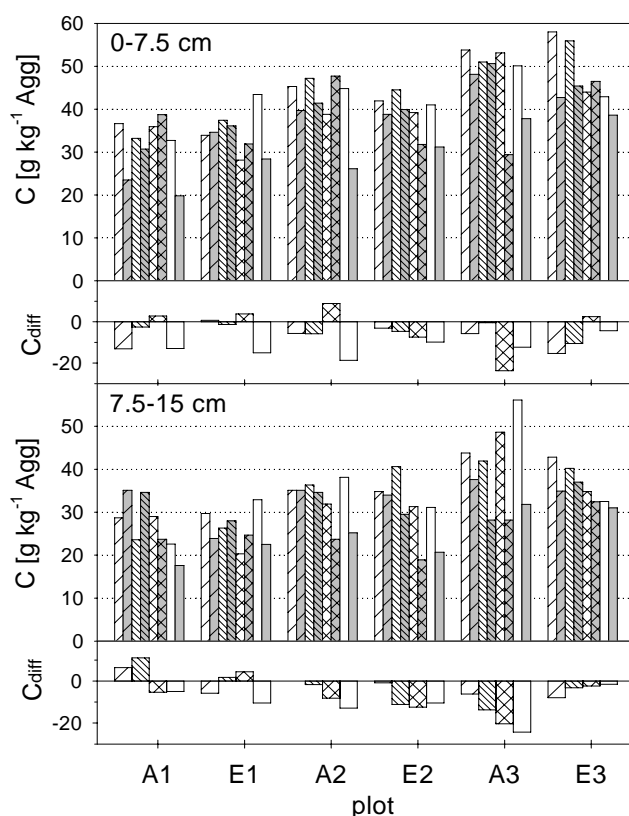

aggregate size classes (see above) indicates a shift in soil structure and C storage. Because long-term C storage in the soil is linked to aggregate stability via mechanisms that protect C from rapid decomposition (Six *et al.* 2002), a decrease in aggregates stability could lead to a soil C loss.

Figure 2. C<sub>org</sub> content of the soil fractions in April 1998 and June 2004 and C content difference (Cdiff) between those years in a temperate grassland soil. Legend as Figure 1.

Breakdown of macroaggregates results in a release of labile SOM (Elliott 1986) which is more readily available for microbial decomposition and could lead to enhanced soil respiration. Assuming that respiration was responsible for the C loss, we converted the mean C loss in the uppermost 15 cm between the 4<sup>th</sup> April 1998 and the 16<sup>th</sup> June 2004 observed on A- (0.88 kg C m<sup>-2</sup>) and E-plots (1.22 kg C m<sup>-2</sup>) to CO<sub>2</sub>-C equivalents on an

hourly basis. This corresponded to an average CO<sub>2</sub> efflux of 16.89 and 12.11 mg C m<sup>-2</sup> h<sup>-1</sup> for E and A plots, respectively. Giving that the average measured ecosystem respiration (R<sub>eco</sub>) rates between 1998 and 2006 were 188.94 mg C m<sup>-2</sup> h<sup>-1</sup> for the E plots and 163.43 mg C m<sup>-2</sup> h<sup>-1</sup> for the A plots, this corresponds to 8.9 and 7.4% of the CO<sub>2</sub> fluxes for E and A plots, respectively. Within the high spatial and temporal variation of respiration a possible additional CO<sub>2</sub> efflux caused by the respiration of C<sub>org</sub> would be masked in the comparatively high R<sub>eco</sub> rates.

## Conclusion

In this paper we hypothesis that a shift of plant community structure within six years caused a structural change in soil aggregation and subsequent C losses via mineralization of labile SOM. More C was lost in the CO<sub>2</sub>-enriched plots, indicating a shift from old to more labile C with a higher turnover rate under elevated CO<sub>2</sub>. The mean difference of R<sub>eco</sub> between A and E plots from 1999 to 2005 was 0.24 kg C m<sup>-2</sup> yr<sup>-1</sup>; which indicates that in the CO<sub>2</sub> enriched plots more C was available for rapid decomposition. The higher R<sub>eco</sub> is in line with the higher loss of C<sub>org</sub> in the E plots, which was on average 0.34 kg C m<sup>-2</sup> higher than in the A plots. The recently published findings of a carbon loss from various soils types in Great Britain (Bellamy *et al.* 2005) shows that significant C losses occur on a grand scale. Here we show for the first time that these C losses may be explained by a plant species shift which alters the soil aggregate structure. Further studies are needed to address in more detail if only enhanced respiration or other processes such as C transfer into ground water (Bellamy *et al.* 2005) are responsible for the decrease in C<sub>org</sub>.

## References

- Beare, M. H., M. L. Cabrera, *et al.* (1994) "Aggregate-Protected and Unprotected Organic Matter Pools in Conventional- and No-Tillage Soils." *Soil Science Society of America Journal* 58: 787-795.
- Chung, H., D. R. Zak, *et al.* (2007) "Plant species richness, elevated CO<sub>2</sub>, and atmospheric nitrogen decomposition alter soil microbial community composition and function." *Global Change Biology* 13: 01313.
- Bellamy, P. H., P. J. Loveland, *et al.* (2005) "Carbon loss from all soils across England and Wales 1978-2003." *Soil Science Society of America Journal* 50: 627-633.
- Elliott, E. T. (1986) "Aggregate Structure and Carbon, Nitrogen, and Phosphorus in Native and Cultivated Soils." *Soil Science Society of America Journal* 50: 627-633.
- Eviner, V. T. and F. S. Chapin III (2002) "The influence of plant species, fertilization and elevated CO<sub>2</sub> on soil aggregate stability." *Plant and Soil* 246: 211-219.
- Harris, D., W. R. Horwath, *et al.* (2001) "Acid Fumigation of Soils to Remove Carbonates Prior to Total Organic Carbon or Carbon-13 Isotopic Analysis." *Soil Science Society of America Journal* 65: 1853-1856.
- Jäger, H. J., S. W. Schmidt, *et al.* (2003) "The University of Giessen Free-Air Carbon Dioxide Enrichment Study: Description of the Experimental Site and of a New Enrichment System." *Journal of Applied Botany*
- Janze, S. (2006) Auswirkungen von erhöhtem CO<sub>2</sub> auf die Vegetation eines Grünlandes. Dissertation. Department of Plant Ecology. Justus-Liebig University, Gießen, p.135.
- Jastrow, J. D. (1996) "Soil aggregate formation and the accrual of particulate and mineral-associated organic matter." *Soil Biology and Biochemistry* 28(4/5): 665-676.
- Kammann, C., L. Grünhage, *et al.* (2005) "Response of aboveground grassland biomass and soil moisture to moderate long-term CO<sub>2</sub> enrichment." *Basic and Applied Ecology* 6: 351-365.
- Latif, M. A., G. R. Mehuys, *et al.* (1992) "Effects of legumes on soil physical quality in a maize crop." *Soil Science Society of America Journal* 56: 103-108.
- Leadley, P. W., P. A. Niklaus, *et al.* (1999) "A field study of the effects of elevated CO<sub>2</sub> on plant biomass and community structure in a calcareous grassland." *Oecologia* 118: 39-49.
- Six, J., A. Carpentier, *et al.* (2001) "Impact of elevated CO<sub>2</sub> on soil organic matter dynamics as related to changes in aggregate turnover and residue quality." *Plant and Soil* 234(1): 27-36.
- Six, J., R. T. Conant, *et al.* (2002) "Stabilization mechanisms of soil organic matter: Implications for C-saturation of soil." *Plant and Soil* 241: 155-176.
- Six, J., E. T. Elliott, *et al.* (1998) "Aggregation and soil organic matter accumulation in cultivated and native grassland soils." *Soil Science Society of America Journal* 62: 1367-1337.
- Tisdall, J. M. and J. M. Oades (1982) "Organic matter and water-stable aggregates in soils." *Journal of Soil Science* 33: 141-163.
- van Veen, J. A. and E. A. Paul (1981) "Organic carbon dynamics in grassland soils. 1. background information and computer simulation." *Canadian Journal of Soil Science* 61: 185-201.

# Nitrate leaching and mineralization of N from soil and manure for an Italian ryegrass crop under Mediterranean conditions

Domingo Olivé F.<sup>1</sup>, Roselló Martínez A.<sup>1</sup>, Serra Gironella J.<sup>1</sup>, Salvia Fuentes J.<sup>1</sup> and Teixidor Albert N.<sup>2</sup>

<sup>1</sup>*Pla per la millora de la fertilització nitrogenada. IRTA- Experimental Agrícola Mas Badia, Mas Badia, E-17134 La Tallada d'Empordà, Catalonia-Spain*

<sup>2</sup>*Departament d'Agricultura, Alimentació i Acció Rural. Government of Catalonia, Mas Badia, E-17134 La Tallada d'Empordà, Catalonia-Spain*

## Abstract

N budget method was used to quantify N mineralization from soil and previous dairy manure or pig slurry applications on different ryegrass (*Lolium multiflorum* Lam. ssp. *alternativum*) trials carried out in 2001-02, 2002-03, 2003-04 and 2005-06, with different rates of mineral N and types of N and manure application. Trials were located in north-east of Catalonia on *Calcic Haploxeralf* (loamy to loamy-clay textured) and *Typic Xerofluvent* (loamy to loamy-sand textured) soils. The field was rainfed (600 mm average annual rainfall) under Mediterranean climatic conditions. Crop was sown early September each year and cut three times (end of December, mid March and mid May). Soil and manure N mineralization ranged from 204 to 372 kg N ha<sup>-1</sup> for the whole cropping period. First and second cutting period (autumn and winter) would account for more than 74% of this mineralization, suggesting that N mineralization is hardly limited on very mild winter areas. Unaccounted N in the N budget increased as N rate did. Soil and manure N mineralization contributed to ryegrass N nutrition with 45 to 75% of the amount of N taken up by the crop (450 kg N ha<sup>-1</sup> yr<sup>-1</sup>, interannual average). Due to the early sowing for ryegrass and its rapid growth at the start, this crop can avoid drainage caused by heavy autumn rainfall events on Mediterranean climate.

Keywords: N budget, pig slurry, lysimeters, ammonium volatilization, temporary grassland

## Introduction

Ryegrass crop is usually linked to mixed farms with animal and crop production. This crop usually is grown on fields where manure is periodically applied. Prediction of N mineralization from recently and in-previous-years manure applied may help to better adjust N fertilization of this crop. The N budget method is a good tool to estimate N mineralization that occurred in the field. Other techniques involving removing soil from its usual conditions may produce important changes in the soil and, consequently, vary N mineralization estimates. On the other hand, under Mediterranean conditions, with important rainfall events occurring during autumn when ryegrass is just recently established in the field, N mineralized from manure and soil may be leached and contribute to water Table enrichment with nitrate N. Direct measurements of this variable may reduce uncertainty in the use of other tool where most parameters are estimated but not measured.

## Materials and methods

Two types of trials on N fertilization of rainfed Italian ryegrass (*Lolium multiflorum* Lam. ssp. *alternativum* cv. Trinova) were carried out at two sites in the north-east area of Catalonia under Mediterranean climatic conditions (600 mm average annual rainfall).

First type consisted of four mineral N rates (0, 40, 80 and 120 kg N ha<sup>-1</sup>) applied at dressing after the 1<sup>st</sup> and 2<sup>nd</sup> cut (end of December and mid March respectively) on ryegrass. Those trials were conducted on commercial fields, so following usual agricultural practices other than mineral N fertilization, in years 2001-02, 2002-03 and 2003-04. Trials were located in Monells on *Calcic Haploxeralf* soils (loamy to loamy-clay textured). Dairy manure had been applied on previous crops and years as it is usually done on practice. It was also applied before ryegrass sowing on years 2001 and 2002, but not on year 2003. Crop was sown on early September each year and was last (3<sup>rd</sup>) cut at mid May.

The second type, involving organic and mineral N application, was carried out in 2005-06 on an experimental field at la Tallada d'Empordà on a *Typic Xerofluvent* soil (loamy to loamy-sand textured). Trial treatments were: pig slurry where 3,4-dimethyl pyrazole phosphate (DMPP), a nitrification inhibitor (NI), had been added, a mineral fertilizer (ENTECC 26 ®) which includes this NI, and the same treatments without NI (pig slurry and ammonium nitro sulphate) plus a control without any N application. Treatments were applied before sowing (mid September-05) and after the 1<sup>st</sup> cut (start of January-06) as dressing fertilization at the rates showed on Table 1. Crop was also cut (2<sup>nd</sup> and 3<sup>rd</sup>) at end March and mid May, after a very dry growing period (62.4 mm between February and May).

Table 1. Rate of N applied (kg N ha<sup>-1</sup>) at each treatment and moment of application for experiment on organic and mineral N at la Tallada d'Empordà, 2005-06.

Application date	Control	Treatments*		
		ENTECC 26 and ANS	PS and PS+DMPP Total-N	PS+DMPP NH <sub>4</sub> <sup>+</sup> -N
Presowing (29-9-05)	0	100	98	87
After 1 <sup>st</sup> cut (12-01-06)	0	150	174	110
After 2 <sup>nd</sup> cut	-	-	-	-
Total	0	250	272	197

\*ANS: Ammonium nitro sulphate; ENTECC 26 ®: NSA with DMPP; PS: Pig slurry; PS+DMPP: Pig slurry with DMPP (see text).

Yield and N uptake were recorded at the three cutting moments for all treatments and trials. Also soil (0 to 0.9 m deep) was sampled at presowing and after each cutting moment, and mineral N content determined in each sample. In the second type trial deep drainage was measured by installing passive capillary lysimeters (Gee *et al.*, 2003) in each plot. Each lysimeter records continuously the amount of drainage and allows the extraction of drainage water from a sampling reservoir. Nitrate-N content can be determined in each of the drainage water sample obtained and therefore the amount of N leached calculated. Also volatilization of ammonium was measured (Schjoerring and Mattson, 2001) for all treatments in this trial during 25 days after fertilizer applications.

N budget method was used to quantify N mineralization (on the unfertilized plots for first type of experiments and for all plots on the second type) from soil and previous dairy manure applications in all trials.

## Results and discussion

N budget on the unfertilized plots allowed calculations of minimum amount of N mineralization from soil and manure in each cutting period for trials on mineral N applications (Table 2). Soil and manure N mineralization ranged from 204 to 372 kg N ha<sup>-1</sup> for the whole cropping period. First and second cutting period (autumn and winter) would account for more than 74% of this mineralization, suggesting that N mineralization is hardly

limited on very mild winter areas. Soil and manure N mineralization accounted for 45 to 75% of the amount of N taken up by the crop ( $450 \text{ kg N ha}^{-1} \text{ yr}^{-1}$ , interannual average).

Table 2. N budget for trials on mineral N fertilization of ryegrass at Monells (north-east of Catalonia).

<i>Period considered</i>	<i>Rainfall (mm)</i>	<i>Mineral N fertilization rate (kg N ha<sup>-1</sup>)</i>	<i>Mineral soil N content variation (kg N ha<sup>-1</sup>)</i>	<i>Crop N uptake (kg N ha<sup>-1</sup>)</i>	<i>N mineralized from soil and applied manure OM (kg N ha<sup>-1</sup>)</i>	<i>Unaccounted for N (kg N ha<sup>-1</sup>)</i>
<b>2001-02 cropping period</b>						
Sowing to 1st cut	109		-71	196	123	-
		0	-56	203		0
1st to 2nd cut	93	40	-59	224	144	22
		80	-63	234		55
		120	-44	230		80
		0	-20	129		0
2nd to 3rd (last) cut	200	40	-16	116	105	50
		80	-18	138		69
		120	-25	160		95
<b>2002-03 cropping period</b>						
Sowing to 1st cut	201		-131	187	99	-
		0	-76	120		0
1st to 2nd cut	106	40	-77	128	42	33
		80	-74	138		60
		120	-75	150		89
		0	10	108		0
2nd to 3rd (last) cut	102	40	14	90	116	54
		80	24	105		70
		120	23	123		92
<b>2003-04 cropping period</b>						
Sowing to 1st cut	468		-141	129	-	22
		0	-13	161		0
1st to 2nd cut	105	40	-23	176	146	35
		80	-10	180		59
		120	-15	190		93
		0	3	64		0
2nd to 3rd (last) cut	354	40	-2	60	58	48
		80	-1	65		82
		120	3	61		123

No N was leached (Table 3) from the ryegrass crop on the second type trial, despite important rainfall events occurred, concentrated in autumn and early winter, suggesting that due to the early sowing for ryegrass and its rapid growth on Mediterranean climate, this crop can avoid drainage caused for heavy autumn rainfall events. Volatilization of ammonium (Table 3) from slurry application at presowing (quickly buried) and after 1<sup>st</sup> cut (not buried) was not agronomically significant (especially at presowing) and no differences were found with N volatilization from mineral fertilizers. Low amounts of N losses from this trial may suggest that results from N budget applied to the first type trials, where N leaching and volatilization were not measured and, therefore, were not considered, may be a good estimation of N mineralization from soil and manure organic matter on those conditions.

N mineralization pattern for the second type trial (Table 3) differed from the first type one. Soil and manure N mineralization is negative (immobilization) during the sowing to 1<sup>st</sup> cut period. The very low soil water content during preceding summer and spring time did not allow the decomposition of buried straw from preceding winter cereal crop. It occurred when

autumn rainfall events allowed it, producing the immobilization of N in the soil and N mineralized during this period. In this trial, mineralization occurred mainly during 2<sup>nd</sup> to 3<sup>rd</sup> cut period, despite the relatively dry soil due to low rainfall occurred, accounting for on average two thirds of N mineralization occurred after 1<sup>st</sup> cut (131 kg N ha<sup>-1</sup>).

Table 3. N budget parameters for experiment on organic and mineral N fertilization of ryegrass at la Tallada d'Empordà (north-east of Catalonia), 2005-06.

<i>Period considered</i>	<i>Rainfall (mm)</i>	<i>Treatment*</i>	<i>Mineral soil N content variation (kg N ha<sup>-1</sup>)</i>	<i>Crop N uptake (kg N ha<sup>-1</sup>)</i>	<i>N leached below root zone (kg N ha<sup>-1</sup>)</i>	<i>N volatilized as ammonium (kg N ha<sup>-1</sup>)</i>	<i>N mineralized from soil OM and pig slurry (kg N ha<sup>-1</sup>)</i>
Sowing to 1st cut	252	Control	55	29	0	3	-23
		ANS	43	58	0	4	-82
		ENTEC 26	66	64	0	6	-96
		PS	25	71	0	6	-33
		PS+DMPP	55	64	0	8	-66
1st to 2nd cut	169	Control	62	97	0	3	38
		ANS	36	225	0	4	44
		ENTEC 26	42	189	0	5	3
		PS	53	213	0	11	61
		PS+DMPP	36	199	0	21	73
2nd to 3rd (last) cut	23	Control	-27	84	0	-	111
		ANS	-15	77	0	-	92
		ENTEC 26	-11	79	0	-	90
		PS	-12	64	0	-	76
		PS+DMPP	-8	58	0	-	66

\*NSA: Ammonium nitro sulphate; ENTEC 26 @: ANS with DMPP; PS: Pig slurry; PS+DMPP: Pig slurry with DMPP (see text).

This total amount after 1<sup>st</sup> cut is not basically different from the mineralization occurred on the first type trials for the same period, although rainfall distribution may differ considerably. Valé et al (2007) suggest that mineralization on soils where water stress is frequent (i.e.: Mediterranean conditions) may not decrease as much as in other soils where microbial biomass is not adapted to that situation.

## Conclusions

Soil and manure N mineralization contributes with 45-75% to ryegrass N nutrition, with N mineralization ranging from 204 to 372 kg N ha<sup>-1</sup> for the whole cropping period. N losses through leaching, during the cropping period, and volatilization, when mineral or organic N is applied, are very low under the conditions of the experiments.

## References

- Gee G.W., Zhang Z.F. and Ward A.L. (2003) A modified vadose zone fluxmeter with solution collection capability. *Vadose Zone journal*, 2, 627-632.
- Schjoerring J.K. and Mattson M. (2001) Quantification of ammonia exchange between agricultural cropland and the atmosphere: Measurements over two complete growth cycles of oilseed rape, wheat, barley and pea. *Plant and Soil*, 228, 105-115.
- Valé M., Laurent F., Mary B., Justes E. and Mangin M. (2007) Effets de la température et de l'humidité du sol sur la minéralisation de l'azote organique. *Perspectives agricoles*, 331, 46-49.

# Indicators to predict biodiversity quality of low intensity grazing areas in Switzerland

Walter T., Grünig A., Schüpbach B. and Schmid W.

*Agroscope Reckenholz-Tänikon Research Station ART  
PÖL, Projekte Ökologie und Landwirtschaft, Schinznach-Dorf*

## Abstract

The Swiss Federal Office for Agriculture (FOAG) aims at promoting permanent pastures used at low intensity and therefore bearing high quality of biodiversity by means of a new incentive programme. The launch of the programme is in 2008. Therefore, FOAG commissioned in 2003 Agroscope Reckenholz-Tänikon (ART) to elaborate indicators, enabling a reproducible assessment of low intensity grazing areas in terms of biodiversity which qualify for incentive payments. Vascular plants, butterflies, grasshoppers as well as the occurrence of landscape features such as hedgerows, single trees, small streams, dry stone walls, etc. have been selected as indicator groups. In 2004, a field survey was conducted involving a stratified random sample of 184 pasture areas. Subsequently, the vegetation relevés and the fauna assemblages were evaluated individually by trained vegetation and fauna experts based on their own appreciation system deliberately without instruction. These experts scored 1 for good quality or 0 for poor quality individually each of the vegetation relevés or fauna assemblages. Based on these scores we were able to identify both floristic and faunistic indicator species representing overall high biodiversity quality of grazing areas. In addition, we correlated the fauna quality scores with the proportion of occurring landscape elements. The results were used to evaluate statistically a biodiversity-quality key consisting of about 30-50 flora, 7 fauna taxa and 6 landscape features for ongoing field tests. Moreover, information on the grazing management of the surveyed grazing areas will enable us to gain more evidence for the association between biodiversity and land use.

Keywords: biodiversity, pasture, grazing, indicator value, vascular plants, grasshopper, butterfly, ecological compensation

## Introduction

Switzerland's farmland area (= Used Agricultural Area) comprises approximately 1 Mio ha or one-quarter of the country's surface, of which, approximately 600000 ha is intensive permanent grassland and less than 20000 ha is unfertilised rough grazing. Additionally, there are another 600000 ha of Summer Grazing Areas. By means of a new incentive programme, the Swiss Federal Office for Agriculture (FOAG) aims to maintain and promote permanent unfertilised pastures used at low intensity and therefore bearing high biodiversity. The launch of the programme is 2008. However the programme will exclude the Summer Grazing Area. As a consequence, FOAG commissioned in 2003 ART to elaborate an expert system, enabling a reproducible assessment of grazing areas in terms of biodiversity (flora, fauna, landscape elements). As science has given so far considerable attention to the analysis of the impact of grazing on both vegetation and flora, only little is known about the fauna.

## Material and methods

Vegetation (1-5 vascular plant species list, depending on the size and heterogeneity of the grazing area, each on a 25 m<sup>2</sup> plot, once between the end of May and the end of July), fauna (mainly butterflies and grasshoppers, species list and frequency on transects, three times between the end of May and the end of July), and the proportion of occurring landscape elements (such as hedgerows, single trees, shrubs, small streams, ponds, dry stone walls, outcrop boulders, etc.) were selected as indicator groups providing the information needed to predict the biodiversity-quality of grazing areas, which justify an incentive-payment. In 2004, a field survey was conducted involving a stratified random sample of 184 areas, which were grazed regularly for the last 10 years at least. To construct a representative sample of nearly 200 grazing areas, the population of the regularly grazed areas as provided by the Swiss Federal Statistical Office - were grouped into 3 strata comprising

- 5 main biogeographical regions (Jura Mountains, Central Plateau, Wet Central Alps, Dry Central Alps, Southern Alps),
- 2 grazing types (cattle, sheep),
- and 3 types of nutrient status (poor, intermediate, rich).

Subsequently, the flora and fauna data were evaluated by 2 groups of 5 trained vegetation experts and 5 experienced fauna scientists, respectively. These experts examined individually and eventually scored, i.e. 1 for quality and 0 for non-quality, based on their own appreciation system deliberately without instruction each of the 457 vegetation relevés or each of the 184 fauna assemblages. Thereupon, the five 0/1 expert-scores of each vegetation relevé and each fauna assemblage, respectively, were summed up to a final quality score spanning from 0 to 5 (5 being the best score). In addition, to identify the best flora and fauna taxa indicating a quality score higher than 3 (quality taxa), the Dufrène and Legendre (1997) method was used. Furthermore, we correlated the fauna quality scores with the frequency of occurrence of landscape elements such as hedges and groves; single shrubs and single trees; bare ground with cobbles, gravel, or sand; dry stone walls; small streams.

Both the expert's quality scores and the number of taxa indicating a quality score higher than 3 for the vegetation or the fauna were correlated with the grazing intensity (Pearson's *r*). Grazing intensity was measured by the live stock units per hectare multiplied with the grazing duration (LSU/ha)\*dd. Furthermore, we used one-way ANOVA to test whether fauna quality score depended on pasture type (cattle vs. sheep). Pearson's *r* correlations were also used to examine the relationship between grazing rotation, grazing duration, hedge proportion and stream length, and the number of fauna quality taxa. For testing, fauna quality taxa were square root transformed to achieve normality.

## Results and discussion

Flora and fauna: There was a quite good agreement among experts in their scoring of quality at proportions of 86% for vegetation relevés and 80% for fauna assemblages (scores 0, 1, 4, and 5 in Figure 1). This clear outcome, reflected by the u-shape of the score distribution, suggested setting the quality threshold for both flora (vegetation) and fauna at a level of >3 expert scores. The subsequent calculation of indicator values according to Dufrène and Legendre (1997) yielded a hierarchical list comprising the top 30 flora taxa indicators for flora quality: *Helianthemum spec.*; *Cirsium acaule* Scop. and *Carlina acaulis*; *Hippocrepis spec.* incl. *Coronilla spec.* and *Medicago falcata*; *Trifolium montanum* L.; *Scabiosa spec.*; *Prunella grandiflora* (L.) Scholler; small *Carex spec.*; *Polygala spec.*; *Anthyllis spec.*; *Pimpinella spec.*; *Briza media* L.; *Centaurea spec.*; *Hieracium pilosella* L.; *Teucrium spec.*; *Globularia spec.*; *Buphthalmum salicifolium* L.; *Onobrychis spec.*; *Orchidaceae spec.*; *Asperula cynanchica* L.;



*Festuca ovina* aggr. incl. *Nardus stricta*; *Gentiana spec.*; *Brachypodium spec.*; *Campanula spec.*; *Galium verum* L.; *Koeleria spec.*; *Potentilla neumanniana* Rchb; *Linum spec.*; *Thymus spec.*; *Euphorbia cyparissias* L.; *Salvia spec.*

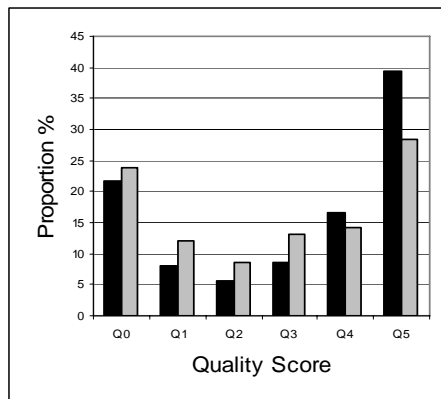

Figure 1: Evaluation of the ecological quality of a representative sample of low-intensity pastures in Switzerland. Distribution of 457 vegetation relevés (black bars) and 184 fauna records (grey bars) according to 6 quality score classes. Q0 (= Mark 0 by all 5 experts) being the poorest and Q5 (= Mark 1 by all 5 experts) the best class.

Fauna-taxa indicating a good fauna quality are: Grasshoppers with red or blue coloured back-wings such as *Oedipoda spec.*, *Calliptamus spec.*, *Psophus stridulus*, *Sphingonotus spec.*; the blue butterfly *Lysandra bellargus*; *Zygaenidae* with red colour on their wings; Red and dark-brown cross-hatched butterflies

*Boloria spec.*, *Brenthis spec.*, *Clossiana spec.*, *Fabriciana spec.*, *Mellicta spec.*, *Melitaea spec.*, *Mesoacidalia aglaja*; Fritillary-butterflies with white spots *Carcharodus spec.*, *Pyrgus spec.*, *Spialia sertorius*; Brown bush-crickets with long wings *Platycleis spec.*; the bush-cricket *Decticus verrucivorus*. These and more taxa are eligible for the use in a valuation key. Based on these results we have first proposed 64 flora and 34 fauna taxa for the valuation key which should also be easily recognisable by the field advisors. For a better practical use reduced taxa – numbers, 30-50 flora and 7 fauna taxa were also proposed. The reduction of the taxa number in the valuation key may lead to it being more practical to use, but of course the stability of the valuation-key will decrease.

Landscape elements: The box plots show that a woody plant-proportion > 15% of grazing surface area (Figure 2) or a natural small stream-length of at least 50 m coincides well with the number of fauna quality taxa (hedge proportion:  $r = 0.37$ ,  $p < 0.001$ ; stream length:  $r = 0.27$ ,  $p < 0.001$ ). Thus such landscape element threshold-values are suitable indicators for fauna quality and are suitable for the use in a valuation key.

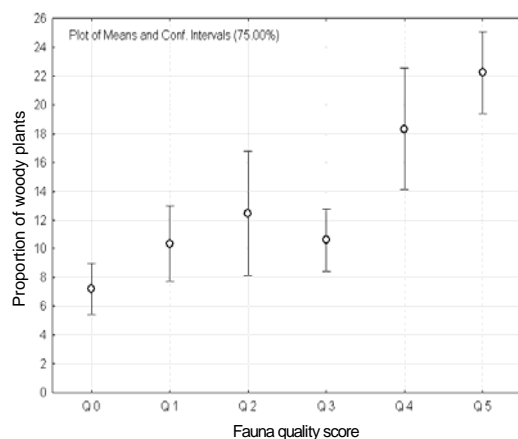

Figure 2: Proportion of pasture area covered by woody plants (trees, groves, hedges, scrub, etc.) vs. fauna quality scores (0=poorest quality, 5=best quality).

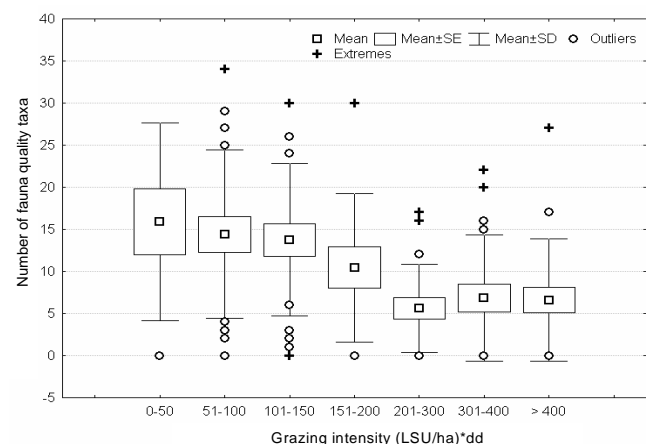

Figure 3: Number of fauna quality taxa vs. grazing intensity showing a swing between 150 and 200 (LSU/ha)\*dd.

Grazing management: There is a negative correlation between the grazing intensity, and the fauna-quality ( $r = -0.37$ ,  $p < 0.001$ ). The swing of quality (more than 12 fauna quality taxa) to non-quality occurs at about 150-200 (LSU/ha)\*dd (Figure 3). This value is confirmed by

Boschi and Baur (2006) for gastropod-communities or Gonth (1994) for butterflies in the Swiss Jura Mountains. No difference in quality was found between sheep and cattle pastures (ANOVA,  $F = 0.54$ ,  $p = 0.46$ ). Moreover the quality of fauna is more negatively correlated with the grazing rotation frequency ( $r = -0.51$ ,  $p < 0.001$ ) than with the grazing duration ( $r = -0.23$ ,  $p = 0.014$ ). Thus we recommend a low grazing intensity of  $< 150$  (LSU/ha)\*dd and low rotation frequencies (maximum 2 rotations) to maintain or achieve quality.

Regional differences: There are large quality-differences between the 5 regions Jura Mountains, Central Plateau, Wet Central Alps, Dry Central Alps and Southern Alps (Figure 4). In the Southern Alps 90% of the extensively used pastures achieve a flora quality score  $> 3$  and a 100% have a fauna quality score  $> 3$ . The opposite is the case in the Central Plateau where 60% of flora quality is  $< 3$  and more than 90% of fauna quality is  $< 3$ . These differences can not be explained by chorological (vertical and horizontal) differences of the quality taxa, which is almost the same for all regions. The lack of pastures with quality in the Central Plateau must be recognised as a consequence of recent and past management practices and the low resiliency of the requested qualities. Thus, it is much easier and more efficient to maintain rather than restore quality. We strongly recommend the implementation of the same threshold-value for quality in all the regions and not, for example, a weaker threshold in the Central Plateau and a stronger value in Southern Alps. In addition it would be even more appropriate to change the actual yes-no-payment system into a continuous quality oriented one.

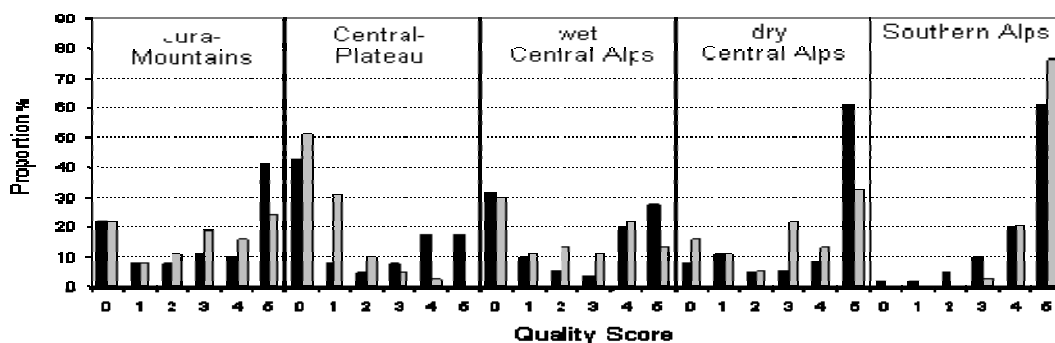

Figure 4: Biodiversity assessment of 184 extensively used pastures according to the 5 main regions of Switzerland. Quality scores are based on both 457 vegetation (black bars) and 184 fauna records (grey bars) which hence have been evaluated individually by 2 teams of 5 vegetation and fauna experts (0=poorest, 5=best quality).

## Conclusion

There is evidence that representative field surveys of both flora and fauna – after evaluation by a group of experts – may provide appropriate means to assess consistently the biodiversity quality of grazing areas. In addition to the selection of characteristic fauna and flora taxa, also various landscape elements such as the length of hedgerows or streams of a given area were taken into account. Eventually, parameters describing the grazing management in terms of stocking rate, stocking period, and rotation frequency, turned out to be very useful indicators to predict the pastures' biodiversity quality.

## References

- Boschi C. and Baur B. In press. Effects of management intensity on land snails in Swiss nutrient-poor pastures. *Agriculture, Ecosystems and Environment*, in press.
- Dufrène M. and Legendre P. (1997) Species assemblages and indicator species: The need for a flexible asymmetrical approach. *Ecological Monographs*, 67(3), 345-366.
- Gonth Y. (1994) La faune des Lépidoptères diurnes (*Rhopalocera*) des pâturages, des pelouses sèches et des prairies de fauche du Jura neuchâtelois. *Mitt. Ent. Ges.*, 67, 17-36.

# Effect of unguarded mixed grazing on Atlantic mountain heathlands

Mandaluniz N., Ruiz R. and Oregui, L.M.

*NEIKER A.B. Box 46 E-01080 Vitoria-Gasteiz (Spain)*

## Abstract

The current trends observed in livestock systems in Europe (intensification, lesser grazing practices, etc) will obviously exert important effects upon the environment. This paper focuses on the effect of livestock on the dynamic of Atlantic mountain heathlands. The study was carried out between spring 2003 and autumn 2005 to assess the evolution of both, sward (height, biomass and dead matter) and shrub (cover and biomass) components under two treatments: livestock presence and absence. According to the collected data, the presence of livestock helped to maintain sward height, biomass and dead matter content (3.2 cm, 1200 kg DM/ha and 27%, respectively) as well as shrub cover and biomass (14% and 132 kg DM/ha, respectively). Contrarily, livestock absence during 3 grazing seasons, involved a significant increase of sward height, biomass and dead matter percentage (13.6 cm, 2850 kg DM/ha and 67%, respectively) and shrub cover and biomass (38.5% and 950 kg DM/ha, respectively). According to these results, keeping livestock grazing systems in such areas is crucial to maintain these Atlantic open heathlands. In the short term, livestock presence would reduce vegetation degradation and the exposure to fire risks. Livestock absence in short-term, contrarily, would increase both, sward and shrub content. Longer monitoring studies are necessary to study the long-term dynamics of these communities in order to propose more sustainable management practices.

Keywords: mountain pastures, livestock grazing effect on vegetation, sward and shrubs, dead matter, biomass

## Introduction

Eastern European countries own huge extensions dominated by open heathlands (Alonso, 2004), protected by the European Habitat Directive (Habitat Directive 97/62/EU). Most of these communities are located in mountain areas where traditionally livestock has played a determinant role in modelling the ecosystem (San Miguel, 2003).

However, current trends observed in livestock systems in Europe (intensification, lesser grazing practices, etc.) will obviously exert important effects upon the structure and composition of these rangelands. Thus, the understanding of the effect of livestock on these communities becomes very important when managing these areas.

Previous studies carried out in these latitudes in Atlantic and Pyrenean mountains (Bartolome *et al*, 2000; López, 2006, Riedel *et al*, 2005), demonstrate that the decline of livestock pressure on these areas has caused a process of secondary vegetation succession towards shrub invasion. During the first stages of this succession a beneficial effect for animal production and conservation is observed, while in the second stages, vegetation biodiversity and livestock accessibility decrease, and fire risk increase dramatically (Bartolome *et al*, 2000; Casassus *et al*, 2005; Riedel *et al.*, 2005). Due to all these considerations, this paper focuses on the effect of livestock on the dynamics of Atlantic mountain open heathlands.

## Materials and methods

The current study was carried out in the Natural Park of Gorbeia (43°N 2.5°W) (Atlantic region of the Basque Country, Northern Spain). In this area, grasslands and heathlands are combined in different covers in altitudes above 800 m, shaping a particular environment that has traditionally been ranged by mixed and unguarded livestock (Casasus *et al*, 2005).

Three locations, representative of the different areas of the Park were selected for the study. In spring 2003, five plots (10x10m) were fenced to avoid grazing. These plots were located in open heathlands composed mainly by shrubs as heather (mainly *Erica vagans*, followed by *E. cinerea*, *E. ciliaris* and *E. tetralix*) and gorse (*Ulex europaeus*). Every individual shrub (n=243) was identified along two types of fixed transect previously defined (1x10m): one out and another one inside the plots.

Transects were monitored in spring and autumn of 2003 and 2005, before and after the grazing season. The following measurements were taken to assess the effect of grazing on both the sward (pasture height, biomass and dead matter content) and the shrub (volume and cover) component of these open heathlands.

### 1. Effect of grazing on the sward component

Pasture height was measured by means of a manual stick (H.F.R.O., 1979), 0.5 cm of precision, to be used later as an indirect estimator of sward biomass (Mandaluniz *et al*, 2005). Biomass accumulation was corrected by the percentage of sward cover in each case.

Sward samples were cut by scissors and dried to estimate sward dead matter (SDM). Samples were separated (dead/green) manually in the laboratory, dried in the oven (60°C/48h) and weighted to estimate percentage of each one expressed in DM.

### 2. Effect of grazing on the shrub component

Shrub cover was estimated measuring the longitudinal and transversal diameter of the shrubs and considering as the interior area of an ellipse of each transect.

Shrub volume was estimated measuring the longitudinal and transversal diameters, as well as the maximum height (Torrano, 2001). Finally, shrub biomass accumulation was related to volume for the 2 predominant species, heather (*E. vagans*) and gorse (*U. europaeus*), representing the 69% of total number of shrubs, developing prediction equations (heather n=23; and gorse n=18).

All data were analysed by a general linear model considering the following fixed effects: grazing management (grazed vs. non-grazed), year (2003 vs. 2005), season (spring vs., autumn) and their interactions.

## Results and discussion

Studied open heathlands were composed by  $85 \pm 2\%$  of sward. Average sward height, dead matter and corrected biomass were  $4.1 \pm 0.8$  cm,  $7.6 \pm 4.5\%$  SDM and  $1400 \pm 450$  kg DM/ha, respectively. The shrub component covered the rest of the surface of the heathlands, which means an average accumulation of  $27.5 \pm 21.5$  kg MS/ha. According to previous data, these communities had quite a good quality pasture (Mandaluniz *et al*, 2005) and a livestock pressure of 1.5 LU/ha, similar to that in grasslands (Casasus *et al*, 2005).

### 1. Effect of grazing on the sward component

Average sward height was  $7.4 \pm 4.8$  cm, similar to other mountain pastures of Atlantic mountains (Riedel *et al*, 2005; Torrano, 2001). According to the statistical analysis, grazing management, year and their interaction showed significant differences upon average sward height (Table 1). Obviously, the initial sward height was similar in both grazing management and it was maintained in grazed areas. However, sward height was

significantly increased in non-grazed ones, but more significantly after 2 seasons as a consequence of exclusion from livestock, with coincides with the results obtained by Riedel *et al.*, 2005.

Sward biomass evolution, corrected by sward cover, was parallel to the height: contrarily to what happened in grazed areas, where no significant differences were observed in terms of biomass, a total accumulation of 1350 kg DM biomass/ha was estimated in non-grazed areas (Table 1). Finally, average SDM was  $26.5\% \pm 22.4$ , with significant differences according to grazing management, year and season and the interaction MxY (Table 1). Being initial SDM similar, lower than 10%, SDM of the grazed areas was maintained while it was significantly cumulated in non-grazed areas, up to a maximum of 67%. As a consequence of the higher accumulation of organic matter in non-grazed plots, a lower microbial activity is observed (Parton and Risser, 1982), as well as a lower decomposition rate.

## 2. Effect of grazing on shrub component

Average shrub cover and volume values were  $21.2\% \pm 11.3$  and  $3.1 \text{ dm}^3 \pm 2.6$ .

The *in-situ* developed equations relating shrub volume and biomass for *E. vagans* (1) and *U. europaeus* (2) were:

$$(1) \text{ Biomass (kg DM)} = 196.78 \times \text{volume (dm}^3) \text{ (R}^2 = 0.90)$$

$$(2) \text{ Biomass (kg DM)} = 368.71 \times \text{volume (dm}^3) \text{ (R}^2 = 0.95)$$

Considering these equations, shrub cover and biomass were significantly affected by the grazing management, year and their interaction. Both parameters tended to be maintained in grazed areas (14% and 132 kg DM/ha, respectively) while a significant ( $P < 0.05$ ) increase was observed in non-grazed ones (38% and 946 kg DM/ha, respectively) (Table 1). This tendency coincides with the results obtained by Casaus *et al.* (2003) in a similar mountain area, where grazing effect maintained shrub biomass. Nevertheless, Bartolome *et al.* (2000) and Riedel *et al.* (2005) observed that grazing tended to reduce but did not stop the increment of shrub biomass in similar rangelands but lower stocking rate (0.15 LU/ha vs 1.5 LU/ha).

Table 1. Lsmeans of the effect of the grazing management (M), year (Y) and season (S) and their interactions on sward height (cm), sward dead matter percentage (SDM), sward biomass (kg/ha) and shrub cover (%), height (cm), volume (dm<sup>3</sup>) and biomass.

	Grazed				Non-grazed				P values					
	2003	2005	2003	2005	2003	2005	2003	2005	M	Y	S	MxY	MxS	YxS
	Spring		Autumn		Spring		Autumn							
Sward component of heathlands														
Height	3.7	4.7	2.6	3.2	4.4	14.9	9.1	13.6	***	***	ns	**	*	*
SDM	8.8	6.0	32.6	26.6	6.4	44.8	31.5	67.2	***	***	***	***	ns	ns
Biomass	1330	1010	1614	1208	1510	2689	2997	2854	***	***	ns	**	*	*
Shrub component of heathlands														
Cover	14.5	17.0	13.7	13.9	15.0	40.6	17.0	38.5	**	**	ns	**	ns	ns
Volume	1.52	1.86	1.67	1.56	1.47	6.81	2.21	7.66	**	**	ns	**	ns	ns
Biomass	125	130	127	132	130	234	148	946	***	***	ns	**	*	*

\*:  $P < 0.05$ ; \*\*:  $P < 0.01$ ; \*\*\*:  $P < 0.001$

M: grazing management (grazed and non-grazed); Y: year (2003 and 2005); S: season (spring and autumn)

## Conclusions

According to the results, the current stocking rates registered in the study area helps to maintaining the sward/shrub ratio, sward height and SDM, avoiding shrub expansion in these Atlantic mountain open heathlands.

In the absence of livestock, these heathlands are ecosystems characterized by a strong dynamics of secondary vegetation succession towards shrub invasion, sward biomass and dead matter accumulation in the short-term.

These tendencies should be confirmed in longer temporal monitoring studies in order to have information that helps to advise and organize the management of these communities, integrating livestock management as an important tool to preserve the natural resources and landscape values in these protected mountain rangelands.

## References

- Alonso (2004) La conservación de los brezales en Inglaterra. Ecosistemas, [www.aeet.org/ecosist](http://www.aeet.org/ecosist)
- Bartolome, J. Franch J. Plaixat J. and Seligman NG (2000) Grazing alone is not enough to maintain landscape diversity in the Montseny Biosphere Reserve. Agriculture, ecosystems and environment, 77, 267-273.
- Casasus I., Bernues A., Sanz A., Riedel J.L. and Revilla R (2003) Utilization of Mediterranean forest pastures by suckler cows: animal performance and impact on vegetation dynamic. In: Animal production and natural resources utilisation in Mediterranean mountain areas. XII Symp. HSAP-FAO, 5-7 June, Ioannina, Greece.
- Casasus I., Mandaluniz N., Ascensio M.A., Perez de Arenaza A., Igarzabal A., Bernues A., Oregui L.M. (2005) Habitat use of livestock ranging in 2 natural parks in northern Spain. *Proc. of the 13th Meeting of the FAO-CIHEAM mountain pastures subnetwork*, Udine, Italy (15-17 September), 127-134 pp.
- H.F.R.O. (1979) Science and hill farming. HFRO 1954-79. Hill Farming Research Organisation. Penicuik, Scotland.
- Lopez Z.G. (2006) Colonización de pastos por arbustos en el Parque Natural del Montseny e influencia de sus características físico-químicas en la preferencia o rechazo por el ganado ovino y caprino. Doctoral Thesis, University of Barcelona.
- Mandaluniz N., Igarzabal A., García A., Oregui L.M. (2005) Forage offer (nutritive value and pasture height) of pastures occurring in the grazing ranges of the Natural Park of Gorbeia (Northern Spain). *Proc. of the 13th Meeting of the FAO-CIHEAM mountain pastures subnetwork*, Udine, Italy (15-17 September), 325-332.
- San Miguel A. (2003) Gestión silvopastoral y conservación de especies y espacios protegidos. In: A. Robels et al (eds.). Pastos, Desarrollo y Conservación. Reunión Anual de la SEEP, 409-421.
- Parton WJ and Risser P.G. (1982) Impact of management practices on the tallgrass prairie. *Oecologia*, 52, 370-375.
- Riedel J.L., Casasus I., Garcia A., Sanz A., Blanco M., Revilla R. and Bernues A. (2005) Effects of livestock grazing on the shrub vegetation biomass in the Sierra de Guara Natural Park (Spain). *XX International Grassland Congress*, 538.
- Torrano L. (2001) Utilización por el ganado caprino de espacios forestales invadidos por el matorral y su impacto sobre la vegetación del sotobosque. Doctoral Thesis, Zaragoza University, Spain.

## Environmental impact of sheep-cattle association under grazing

Decruyenaere V., Hennart S. and Stilmant D.

*Farming Systems Section, Walloon Agricultural Research Centre, 100, rue du Serpont, B-6800 Libramont (Belgium)*

### Abstract

The association of sheep and cattle under grazing leads to more perennial swards and reduces the pressure of gastro-intestinal parasites. However, what is the environmental impact under such a grazing scheme?

To answer this question five grazing systems were compared during two seasons: cattle alone (rotational, as reference and continuous grazing), sheep (continuous grazing), cattle and sheep in a rotational grazing system with mixed and leader-follower schemes. During the first season, the same stocking rate was applied. During the second year, the same cattle stocking rate was applied and sheep came in supplement.

Stocking rates, nitrogen inputs (fertilisers, nitrogen fixation...) and outputs (animal's live weight gains, silage production...) were recorded to calculate nitrogen balance. At the end of the season, soil nitrogen residues were quantified.

Over both seasons, soil nitrogen residues appeared higher for heifers in continuous grazing system (65.6 vs 21.0 kg N-NO<sub>3</sub><sup>-</sup> ha<sup>-1</sup> for the reference). Ewes and heifers association led also to an increase of nitrate leaching risk (40.0 kg N-NO<sub>3</sub><sup>-</sup> ha<sup>-1</sup>). For the second year, autumn grazing days appears as a good indicator of nitrate leaching risk. The link between nitrogen balances and nitrate residues at the end of the season seems to be less relevant.

Keywords: pasture, mixed grazing, nitrate leaching risk, nitrogen balance

### Introduction

To add sheep breeding in a suckling cattle farm is interesting at different points of view. The association of sheep and cattle at pasture leads to more perennial swards and increases pasture productivity. Indeed, at pasture, sheep behaviour is different and complementary to cattle one's. According to their smaller bite size, sheep have the ability to select their diet and so could exploit smaller sward height. Moreover, this association, in a mixed grazing system, leads to a better pasture productivity due to the consumption of cattle refusals by sheep. The management of gastro-intestinal parasites appears also easier. Indeed, sheep clean the pasture from cattle parasites in reason of the specificity of such host-parasite relationship (Hoste *et al.*, 2003). Finally, such diversification has economical advantages: using of existing infrastructure, low starting investment.... But what is the environmental impact of such an association?

The present trial studies the impact of the introduction of sheep aside from cattle herd on the evolution of different indicators aiming to quantify nitrogen lossing risk under grazing. To do so, two grazing systems associating sheep and cattle were compared to cattle or sheep grazing alone during two grazing seasons. For each grazing scheme, nitrogen leaching risk was obtained from soil analysis at the end of the grazing season and nitrogen balance was calculated from nitrogen inputs and outputs quantified during the grazing season.

## Materials and methods

The trial was held during 2004 and 2005 grazing seasons, in Libramont (Belgium), on a permanent pasture, for the most part composed of good digestibility grass (68%) and white clover (30.5%). This pasture was divided in five grazing blocks.

The treatments compared were: cattle (Belgian Blue Heifers, 14 months old for 357 kg live weight at the start of the grazing season) grazing alone in a rotational (CR) and in a continuous (CC) systems; sheep (Swifter ewes with lamb, 53 kg of live weight and 1.95 lambs per ewe at the start of the grazing season) grazing alone in a continuous system (SC); cattle with sheep under a simultaneous (CSS) and a leader-follower (CSLF) grazing system. In 2004, rotational grazing systems are organized on 3 paddocks for CR and on 6 paddocks for CSS and CSLF. In 2005, all rotational grazing systems are organized on 4 paddocks. For the CSLF scheme, cattle were followed by sheep. In 2004, the same total stocking rate was applied for all grazing systems ( $3.0 \text{ Livestock Units (LU) ha}^{-1}$ ), ewes have taken the place from  $0.84 \text{ cattle LU ha}^{-1}$ . In 2005, the same cattle stocking rate was applied ( $2.9 \text{ LU ha}^{-1}$ ). In the mixed grazing systems, ewes came in supplement to reach  $3.7 \text{ LU ha}^{-1}$ .

Nitrogen inputs came from nitrogen fertilizers applied on an organic (manure compost;  $\text{N} = 5.6 \text{ kg ton}^{-1}$ ) and/or a mineral form and from nitrogen fixation by white clover.

Compost was applied once, at the end of March. For the year of first application, direct effect of nitrogen from compost was estimated to 30%. However, after more than 5 years of yearly application, due to the post-effects, we can consider that more than 85% of applied nitrogen was used by the plant (Limbourg, 2001). Applications of mineral fertilizers were fractioned with a maximum of  $27 \text{ kg ha}^{-1}$  per fraction. The nitrogen fixation due to legumes was estimated at  $2.12 \text{ kg ha}^{-1}$  per percent of white clover cover in the sward.

Nitrogen outputs came from mowed swards (spring surplus harvested as silage) and from cattle and sheep growths. Animal growths were obtained by weighing cattle and sheep every six weeks along the grazing season. For BBB heifers and according to De Campeneere *et al.* (2000), one kilogram of growth fixed 32 g nitrogen. In sheep the value of 24 g nitrogen per kilogram of growth was selected for ewes and lambs (Greenhalgh, 1986). Nitrogen balance was obtained by subtracting the outputs from the inputs. Soil nitrate residues ( $\text{N-NO}_3^- \text{ kg ha}^{-1}$ ) were quantified in the 0-30 cm superficial soil layer through the analysis of a pooled sample including 30 soil samples per paddock. Finally, nitrogen balance and grazing pressure in autumn, calculated in term of LU multiplied by the number of grazing days on a given paddocks since the 15<sup>th</sup> of August, were compared to soil nitrate residues to test the opportunity to use these parameters as indicator of nitrate leaching risk.

## Results and discussion

Over the two grazing seasons, soil nitrogen residues ( $\text{kg N-NO}_3^- \text{ ha}^{-1}$ ) appears higher when compost is the unique fertilizer applied ( $47.5 \text{ vs } 29.2 \text{ kg N-NO}_3^- \text{ ha}^{-1}$  respectively for organic and mineral fertilizers). Likewise, nitrogen balance is higher with compost application ( $93.8 \text{ vs } 77.7 \text{ kg N ha}^{-1}$  respectively for organic and mineral fertilization).

Results concerning N cycling at the pasture scale are summarized in Table 1. At the grazing system level, CC system leads to higher soil N residues both in 2004 and 2005 ( $65.6 \text{ kg N-NO}_3^- \text{ ha}^{-1}$  across the two seasons;  $F_{(4,21)} = 4.0$ ;  $P = 0.013$ ) while SC scheme leads to smaller soil nitrogen residues with a mean value of  $8.2 \text{ kg N-NO}_3^- \text{ ha}^{-1}$  across the two seasons. Indeed, according to Di and Cameron (2004), N returns in animal urine have a major impact on nitrate leaching in grazed pasture. Now, for an equivalent stocking rate, we can draw the hypothesis that the pasture area covered by cattle urine is smaller than the one's covered by sheep urine. At a given point, the volume of produced urine is also different and lower for sheep. The consequence is a greater  $\text{N-NO}_3^-$  leaching risk below cattle urine patches.



Table 1. Nitrogen inputs and outputs (kg ha<sup>-1</sup>), Nitrogen balance and Nitrate residues in soil. Study of the impacts of grazing systems and stocking rates.

Grazing systems	N-Inputs (kg ha <sup>-1</sup> )		N-Outputs (kg ha <sup>-1</sup> )		N balance (kg ha <sup>-1</sup> )	N-NO <sub>3</sub> soil residues (kg ha <sup>-1</sup> )
	Fertilizers	Legumes fixation	cutting	animal growths		
Year 2004						
CC	27.0	86.7	81.8	20.5	59.5	53.8
CR	38.7	77.2	64.6	16.6	77.7	16.3
SC	/	49.6	/	18.8	30.8	10.9
CSS	43.6	71.3	33.3	22.6	86.7	27.6
CSLF	45.1	56.2	36.9	22.6	72.6	43.3
Year 2005						
CC	63.4	78.9	/	17.6	124.7	77.4
CR	58.9	68.7	/	19.7	107.8	24.6
SC	99.4	29.5	/	17.1	111.8	5.5
CSS	65.5	54.1	/	21.6	98.0	52.2
CSLF	65.5	65.7	/	23.1	108.1	41.3

For rotational grazing (CR, CSS and CSLF), sheep and cattle association tends to increase nitrogen residues in soil even if stocking rates were similar between grazing schemes (year 2004). Compared to 2004, to increase stocking rate with sheep in 2005 led to an increase of N-NO<sub>3</sub><sup>-</sup> content in soil only for CSS system. Across the two grazing seasons, nitrogen outputs linked to animals production were 24% higher for mixed systems (CSS = 1.24 and CSLF = 1.24 in comparison to CR system). These results confirm those of Murphy *et al.* (1994), there are a better herbage utilisation when sheep and cattle are associated.

Nitrogen balance was significantly higher for the 2005 grazing season (75.2 vs 106.6 kg N-NO<sub>3</sub><sup>-</sup> ha<sup>-1</sup> respectively for 2004 and 2005;  $F_{(1,21)} = 19.1$ ;  $P = 0.0003$ ). This increase could be explained by the suppression of the mowing and the increase of nitrogen fertilization. Compared to CR, the cattle-sheep association didn't alter nitrogen balance nor in 2004 neither in 2005. As illustrated in Figure 1, nitrogen balance and grazing pressure in autumn are positively, even if weakling, correlated to nitrogen leaching risk ( $r = 0.29$ ,  $N=31$ ,  $F_{(1,29)} = 2.6$ ;  $P = 0.1$  for nitrogen balance and  $r = 0.40$ ,  $N=31$ ,  $F_{(1,29)} = 5.6$ ;  $P = 0.03$  for the grazing pressure quantified by the number of LU multiplied by the number of grazing days on a given paddock since the 15th of August). In 2005 and for the rotational grazing systems, the relation between grazing pressure and nitrogen leaching in autumn is particularly strong ( $R^2 = 0.67$ ,  $N = 12$ ;  $F_{(1,10)} = 20.5$ ;  $P = 0.001$ ) (Figure 2).

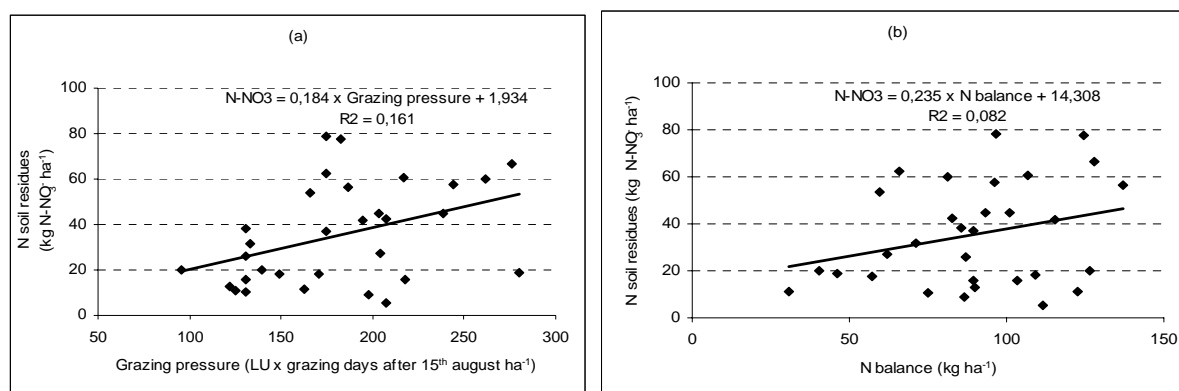

Figure 1: Relation between N soil residues and grazing pressure in autumn (a) or N balance (b)

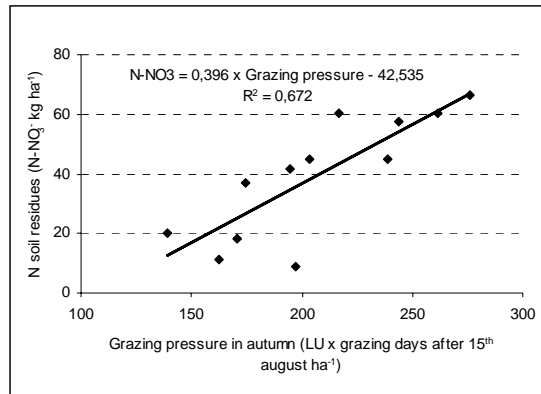

Figure 2: Rotational grazing schemes: relation between soil N- NO<sub>3</sub><sup>-</sup> residues and grazing pressure in autumn (year 2005)

## Conclusions

Sheep and cattle mixed grazing leads to a better herbage utilisation through the consumption of cattle refusals by sheep. On the environmental point of view, soil N- NO<sub>3</sub><sup>-</sup> residues in autumn are higher when sheep graze with cattle whatever the year. Nitrogen balance is positive for all grazing systems and don't appear higher for the mixed grazing. Poor correlations existing between soil N- NO<sub>3</sub><sup>-</sup> residues and both nitrogen balance and grazing pressure illustrate the difficulty to find an indicator adapted to characterize the environmental impact linked to different grazing management.

## Acknowledgements

We would like to thank the Walloon Region, General Direction of Agriculture, Development and Extension Direction for their financial contribution.

## References

- De Campeneere S., Fiems L.O., De Paepe M., Vanacker J.M. and Boucqué C.V. (2000) Compositional data of Belgian Blue double muscled bulls. *Anim. Res.*, 50,43-55.
- Di H.J. and Cameron K.C. (2004) Nitrate leaching in temperate agroecosystems: sources, factors and mitigating strategies. *J. Nutrient Cycling in Agroecosystems*, 64, 3 237-256.
- Greenhalgh J.F.D. (1986) Recent studies on the body composition of ruminants. *Proc. Nutr. Soc.*, 45,119-130.
- Hoste H., Guitard J.P. and Pons J.C. (2003) Pâturage mixte entre ovins et bovins : intérêt dans la gestion des strongyloses gastro-intestinales. *Fourrages* 176, 425-436.
- Limbourg, P. (2001) Phytotechnie de la prairie permanente répondant aux nouvelles exigences écologiques et économiques. Rapport final. CRAW-Section systèmes agricoles.
- Murphy W.M., Mena Barreto A.D. and Silman J.P. (1994) Sward dynamics of a smooth-stalked meadowgrass-dominant white clover sward rotationally grazed by cattle and/or sheep. *Grass and Forages Sci.*, 50, 3, 183-190.
- Williams P.H. and Haynes R.J. (1994) Comparison of initial wetting pattern, nutrient concentrations in soil solution and the fate of 15N-labelled urine in sheep and cattle urine patch areas of pasture soil. *J. Plant Soil*, 162, 1, 49-59.

# The effect of “gyimesi racka” sheep grazing on permanent grassland biodiversity

Szemán L.<sup>1</sup>, Kádár I.<sup>2</sup> and Kovács P.<sup>3</sup>

<sup>1</sup>SzIE, Faculty of Agricultural and Environmental Sciences, Institute for Crop Production, Department of Grassland Management, Gödöllő, Hungary

<sup>2</sup>Research Institute For Soil Science And Agricultural Chemistry Of The Hungarian Academy Of Sciences (RISSAC), Budapest, Hungary

<sup>3</sup>Sárrét KHT, Bakonszeg, Hungary

## Abstract

Grazing has a favorable effect on animals – however, grazing also has a major effect on the plant stock of pastured grasslands. Sheep do not feed plants from urine patches, which may result in a change in the diversity of plants on the pasture.

One of the aims of our research was to examine the effect of animal excreta coverage on sustaining the biodiversity of grasslands. The research took place in Bakonszeg, on nature conservation areas, pasturing “gyimesi racka” ewes. We analyzed the effect of urine induced lush patches on sustaining the diversity of plant species. Results showed that lush patches were grazed unevenly. The outer circle, app. 15% of the patches has been grazed, a further 15-20% has been somewhat grazed, while the middle of the patch, 60-70% remained ungrazed.

In the first growth, grass species in the middle of the lush patch seed heads (40-150 patch<sup>-1</sup>) while on the outer edge of the patch, rhizomatous plants advanced.

The diversity of species on grasslands in nature conservation areas can be sustained by grazing according to good agricultural practice, grazing the appropriate number of animals and using professional grazing methods.

Keywords: sheep grazing, biodiversity, urine patch, nature conservation grassland

## Introduction

The analysis of grazing is important to maintain the plant diversity of pastures on nature conservation areas.

According to Frame (1992), dump excretion is about 1-1,5 kg sheep<sup>-1</sup>, as a total of 0,1-0,2 kg of dump defecated 6-8 times day<sup>-1</sup>. This amount, when added up for the whole grazing period, is app. 300-700 kg (app. 200 - 400 kg dry matter). The expected dump coverage of the pasture is about 0,05-0,07 m<sup>2</sup> / animal. The amount of urine is 1-2 liter sheep<sup>-1</sup> day<sup>-1</sup> as a total of 15-20 excretions. A sheep's urination covers an area of 0.03 – 0.05 m<sup>2</sup> (Haynes and Williams 1993). According to Bristow *et al.* (2006) in the sheep urine, total N ranged from 3.0 to 13.7 g litre<sup>-1</sup> of which an average of 83% was present as urea. Herbage species vary in their tolerance to or recovery from urine scorch or dung smother. Clovers are more susceptible to urine scorch than grasses. Herbage growth rates in and around the patch are stimulated. Herbage response to urine has been attributed to its N concentration and can last for 2 to 3 months (Ledgard *et al.*, 1982).

## Materials and methods

Our grazing experiment was conducted with Hungarian „gyimesi racka” ewes on an alkaline soil nature conservation grassland in 2005/2006, using a grazing method. The aim of the experiment was to analyse the effects of ewe’s dump on the change of the diversity of plant species on the pasture after a spring grazing period. We also examined the effects of urine patches on yield growth, and the feeding behaviour of ewes, by analysing the yields of grazed and partially grazed parts of urine patches. We monitored the number of generative tillers on the non-grazed parts, in order to sustain biodiversity and nature conservation effect. We monitored the change of the ratio of plant species, and examined the effect of grazing on the change of botanical cover of different species.

Grazing was started in early spring to ensure that sheep graze a large area due to the small amount of grass available. Urine scorch patches were marked. The effect of dump on the decay and regeneration of plants, on the grazing of the next growth, and on the generative phase of grasses were monitored.

While grazing the primary growth, sheep consumed only parts of the urine induced lush patches. Plants not grazed could reach generative phase, which supports grassland biodiversity. We also measured the area of urine induced lush patches and the weight of grazed and un-grazed herbage.

The grasses turned dark green on dumped patches therefore they were easy to separate. Based on the grazing effect, patches were divided into three parts: the grazed outer border, where both the shoots and the stems of the grass were grazed; the mildly grazed area, where only the top of the shoots were grazed, resulting in the prevention of flowering; and the un-grazed inner circle, where grasses and other species generated reproductive structures and seed. Generative shoots of the ungrazed plants were collected and counted by species. Each time an analysis of the botanical composition was conducted. Plant coverage and the change of size of uncovered area was also determined.

## Results and discussion

In grazed pasture systems, grazing animals deposit urine and dung causing high nutrient loading to relatively small proportion of the total grazed area.

Grazing was started in early spring. Urine scorch patches were marked. The height of grass enabled the sheep to graze on a certain area only for one day; grazing was repeated on the same area 30 days later. Grazed grasses started flowering. Sheep fully grazed grasses on areas not dumped, while urine patches were only partially grazed.

We analyzed the effect of urine induced lush patches on the diversity of plant species. Results showed that lush patches were unevenly grazed. The outer circle, app. 15% of the patches has been grazed, a further 15-20% has been somewhat grazed, while the middle of the patch, 60-70% remained ungrazed.

Based on the darker green colour of grass, we measured the size of patches and the weight of the ungrazed herbage after grazing. Urine induced lush patches were divided into four groups based of their size (Table 1.). We assumed that the smaller the patch, the greater the ungrazed yield is. We found that this assumption was true only for the biggest areas, while there was no significant difference between the remaining yields. That can be explained by the heterogeneity of grass species’ coverage. The grazing of leguminous plants showed that sheep left more plants on smaller size patches. Plants grazed on the borders of the patches could have grown outside the urine covered area, with only their roots reaching into richer soil, therefore the lack of odour enabled their intense grazing similar to not dumped areas.

The generative tiller number was determined at grasses flowering on the lush patches. Only the species *Alopecurus pratensis*, *Festuca pseudovina* and *Poa pratensis* have grown flowering stems. Flowering *Festuca pratensis* was found only in some of the lush patches. We assumed that generative stems were eaten by the early grazing, which may have resulted in a lack of flowering.

Table 1. Mean herbage biomass (DM g patch<sup>-1</sup>) and flowering tiller number after urine patch (area cm<sup>2</sup>) grazing

Different size urine patch area of grasses	<i>Alopecurus pratensis</i>	<i>Festuca pseudovina</i>	<i>Poa pratensis</i>	Legumes fresh weight	Herbage Dry matter
flowering tiller number					
cm <sup>2</sup>	head patch <sup>-1</sup>			g patch <sup>-1</sup>	
2826	32	-	12	1,4 g	38,2
1923	82	-	9	5,9 g	67,1
1425	49	91	7	4,8 g	54,6
1374	54	-	13	30,4 g	42,4
Patch/head	NS		NS		
Patch/yield				**	NS

\*\* : P < 0.01 and NS: non significant.

There is no explainable difference between the number of shoots and the size of lush patches. *Alopecurus pratensis* had the least (32) shoots on the biggest area, outnumbered by the number of shoots (82) on a smaller area.

Non-grazed area and generative tiller number indicate that grazed pastures are able to renew themselves through a generative way, as an indirect effect of grazing. This indirect effect assumes that urine induced patches are not grazed, and grasses can grow seeds in the primary growth. There are no generative shoots developed in later growths, because the physiological effect of vernalisation end with the grazing of the primary growth, and grasses do not develop a seed stems. In this period, vegetative reproduction comes into forefront on the ungrazed areas of lush patches.

The diversity of grasslands on nature conservation areas can be sustained by grazing according to good agricultural practice.

## Conclusion

Grazing has an effect on the diversity of plants - not only through the pasturing itself, but also through the dumping of sheep. The aim of the experiment was to analyse the effects of ewe's dump on the change of the diversity of plant species on the pasture after a spring grazing period.

Sheep do not eat plants from urine patches, which may affect the diversity of plants on the pasture.

Sheep fully grazed grasses on areas not dumped, while urine patches were only partially grazed. The outer circle, app. 15% of the patches has been grazed, a further 15-20% has been somewhat grazed, while the middle of the patch, 60-70% remained ungrazed.

We assumed that the smaller the patch, the greater the ungrazed yield is. We found that this assumption was true only for the biggest areas, while there was no significant difference between the remaining yields. That can be explained by the heterogeneity of grass species' coverage. The grazing of leguminous plants showed that sheep left more plants on smaller size patches.

Plants not grazed could reach generative phase, which supports grassland biodiversity. There is no explainable difference between the number of shoots and the size of lush patches. *Alopecurus pratensis* had the least (32) shoots on the biggest area, outnumbered by the number of shoots (82) on a smaller area. In the first growth, grass species in the middle of the lush patch seed heads (40-150 patch<sup>-1</sup>) while on the outer edge of the patch, rhizomatous plants advanced.

Non-grazed area and generative tiller number indicate that grazed nature conservation pastures are able to renew themselves through a generative way, as an indirect effect of grazing.

## References

- Bristow A.W., Whitehead C.D. and Soskburn E.J. (2006) Nitrogenous constituents in the urine of cattle, sheep and goats. *Journal of the Science of Food and Agriculture*, 59. 3.387-397
- Frame J. (1992) Improved Grassland Management. *Farming Press* 181-185
- Haynes R. J. and Williams P.H. (1993) Nutrient cycling and soil fertility in the grazed pasture ecosystem. *Advances in Agronomy*, 49. 119-199
- Ledgard S.F., Steele K.W. and Saunders W.M.H. (1982) Effect of urine and its major constituents on pasture properties. *New Zealand Journal of Agricultural Research*, 25 61-68

# Environmental aspects of folding with sheep at permanent grassland

Ondrasek L., Gonda L., Martincova J. and Balcar J.

*Slovak Agricultural Research Centre - Grassland and Mountain Agriculture Research Institute, Mladeznicka 36, 974 21 Banska Bystrica, Slovakia*

## Abstract

Over the 2003 – 2005 growing seasons, effects of folding with sheep on biological and chemical properties of soil (ammonification, nitrification,  $\text{NH}_4^+\text{-N}$ ,  $\text{NO}_3^-\text{-N}$ ,  $\text{C}_{\text{ox}}$ ,  $\text{N}_t$ , P, K, Mg, pH) and on botanical and chemical composition of grassland (crude protein,  $\text{NO}_3^-$ , P, K, Mg) were investigated. Emissions of  $\text{NH}_3$  in the air, and  $\text{NH}_4^+$ ,  $\text{NO}_3^-$  and  $\text{PO}_4^{3-}$  in local surface waters were monitored. The research site (Donovaly, central Slovakia) is the drinking water resource area included in the official Hygienic Protection Zone, Degree 2. The old areas (the phytocoenological sward type - a ruderal nitrophilous community) where animals walked or stayed while having regular rests were still a source of possible mineral N accumulation, mainly as nitrates, because of increased mineralisation ability of soil. While in the new fold (in 2003), animals destroyed sward by poaching, trampling and excreta accumulation. Consequently, intensive nitrogen mineralisation, nitrification and excessive amount of mineral N in soil affected the chemical composition of regenerating sward. An increased  $\text{NH}_3$  content was measured in the air near the folded areas. Nitrogen mineralisation was stimulated also during the two years after folding, but any excessive accumulation of mineral N forms in soil was not found, owing to good sward regeneration. The chemical composition of local surface waters was not influenced due to the long distance from the folded areas.

Keywords: folding, soil properties, permanent grassland, air quality, surface waters

## Introduction

Folding – one of the oldest methods of grassland fertilising – is used mainly in remote sites at high altitudes. However, it should be applied to grassland in compliance with good management practice respecting an appropriate stocking rate at folded sites. If overstocked with animals, excreta accumulation and sward damage by poaching and trampling result in the typical environmental pollution of isolated small areas, especially by mineral nitrogen forms (Ondrasek *et al.*, 2000). Moreover, botanical composition of pasture develops in a negative way, because sward biodiversity decreases and aggressive ruderal species expand (Opitz von Boberfeld, 1994, Novak, 1997). The objective of the presented research was to investigate the dynamics of mineral N content in soil at the sites folded with sheep at the present time and also at the old areas where animals walked and stayed while having regular rests. The agrochemical properties of soil, N mineralisation, changes in the botanical composition and the environmental situation at the adjacent areas were assessed.

## Materials and methods

The research site (Donovaly-Misuty, altitude 970 – 980 m) has been and still is folded with sheep. The area is near an underground drinking water resource (Jergaly) included in the official Hygienic Protection Zone, Degree 2. Effects of folding on soil and sward were investigated at four areas within the research site, namely: Area 1 - folded on 17 May 2003; Area 2 – folded on 5 July 2003; Area 3 – the regular resting place of 500-head sheep flock

during 1987 - 1989; Area 4 – control, zero folding. Areas 1 and 2 were folded with 260-head flock of ewes and ewe lambs in 2003. The folds sized 9 x 9 m were moved to another place every other day. Soil was sampled at depths of 0 – 100 mm, 100 – 200 mm and 200 – 300 mm, respectively, in 2003 (8 July, 9 September, 4 November), in 2004 (19 May, 8 July, 6 October) and in 2005 (13 May, 28 June, 4 August, 14 November). Fresh soil samples with natural moisture content were passed through a 2 mm sieve, then the instantaneous content of  $\text{NH}_4^+\text{-N}$  and  $\text{NO}_3^-\text{-N}$  was measured spectrophotometrically (SKALAR), and also an intensity of total N mineralisation (TMN) as well as the rate of nitrification (NIT) were determined (after 14-day incubation of soil at 25 °C). The dried soil samples were analysed to determine  $\text{C}_{\text{ox}}$  (Tjurin),  $\text{N}_t$  (Kjeldahl), P, K, Ca and Mg (Melich III). The botanical composition was determined in 5 x 5 m plots at the areas using the method of Braun-Blanquet (1964). The content of  $\text{NH}_3$  was monitored in the air. The contents of  $\text{NH}_4^+$ ,  $\text{NO}_3^-$  and  $\text{PO}_4^{3-}$  were analysed in adjacent surface waters.

## Results and discussion

At folding, the high stocking rate results in severely damaged sward by animals trampling and poaching. Consequently, the bio-filtering capacity of sward is disturbed, and in extreme cases, there may be nutrient leaching (mainly mineral N) from soil. The mineral N forms supplied to the folded area from animal excreta are accumulating, because the damaged sward is not able to utilise them and so the mineralisation of nitrogen is stimulated in soil. This was found also at the Donovaly research site. The contents of  $\text{NH}_4^+\text{-N}$  and  $\text{NO}_3^-\text{-N}$  (Table 1) as well as TMN and NIT (Table 2) were high and also the agrochemical properties of soil changed at the freshly folded areas in 2003. An increase in Mg and K content was found. This situation was different in 2004 and 2005 when the content of mineral N forms in soil markedly decreased (Table 1). It can be attributed not only to the decreased intensity of TMN and NIT, but also to nitrogen uptake by the re-grown and well-established sward. High content of mineral N was recorded at the long-term folding with 500 sheep during 1985 – 1987 (Ondrasek *et al.*, 2000). After 17 years (Table 2), TMN and NIT were notably higher at this area than at the control, what is in correspondence also with the increased mineral N forms (Table 1) and with the results of agrochemical analysis (Table 2).

Table 1. Mean content of mineral N forms in the soil horizon over 2003 – 2005

Sampling areas	Soil layers (mm)	Year/Index								
		2003			2004			2005		
		$\text{NH}_4^+\text{-N}$	$\text{NO}_3^-\text{-N}$	$\Sigma$	$\text{NH}_4^+\text{-N}$	$\text{NO}_3^-\text{-N}$	$\Sigma$	$\text{NH}_4^+\text{-N}$	$\text{NO}_3^-\text{-N}$	$\Sigma$
Non-folded control	0 - 100	2.0	0.4	2.4	3.3	1.1	4.5	4.5	0.4	4.9
	100-200	4.1	6.6	10.7	9.0	2.2	11.2	4.1	0.8	4.8
	200-300	5.0	4.4	9.5	5.8	0.9	6.7	5.3	0.4	5.6
Folded on 5 July 2003	0 - 100	33.8	167.0	200.8	5.8	10.8	16.6	4.6	8.0	12.6
	100-200	12.4	63.3	75.8	11.3	7.5	18.8	3.2	4.5	7.7
	200-300	11.9	42.5	54.4	8.0	5.3	13.3	4.4	3.8	8.2
Folded on 17 May 2003	0 - 100	9.9	161.2	171.1	3.9	10.9	14.8	2.3	8.5	10.9
	100-200	10.3	93.1	103.4	8.5	11.0	19.5	2.8	8.9	11.7
	200-300	5.9	44.5	50.4	12.0	11.6	23.6	3.7	6.3	10.0
The animal resting place in 1987 - 89	0 - 100	1.1	16.8	18.0	2.6	17.7	20.3	1.9	15.1	17.0
	100-200	2.0	21.9	23.9	5.3	13.5	18.7	2.6	10.5	13.1
	200-300	1.7	20.6	22.3	6.7	12.7	19.4	4.3	7.0	11.3

$\text{NH}_4^+\text{-N}$  and  $\text{NO}_3^-\text{-N}$  as mg N  $\text{kg}^{-1}$



Table 2. Means of total mineralisation of nitrogen (TMN), nitrification (NIT) and agrochemical analysis of soil, respectively

Sampling areas	Years	Index						
		TMN	NIT	C <sub>ox</sub>	N <sub>t</sub>	P	K	Mg
Non-folded control	2003	5.7	4.8	45.6	4.8	10.2	675.3	443.0
	2004	6.7	6.6	46.8	5.9	5.3	472.9	478.2
	2005	3.8	3.5	45.8	4.6	2.4	244.2	390.6
Folded on 5 July 2003	2003	84.1	68.6	45.0	3.0	11.1	700.4	470.7
	2004	15.5	19.4	47.0	5.0	10.7	556.8	473.8
	2005	20.7	25.5	48.4	5.2	4.4	278.0	455.2
Folded on 17 May 2003	2003	68.3	58.7	44.9	4.7	6.2	205.9	392.5
	2004	17.9	17.8	41.9	5.0	1.8	199.7	388.6
	2005	22.8	23.0	46.2	4.4	1.7	155.1	399.3
The animal resting place in 1987 - 89	2003	36.4	36.8	54.2	5.8	30.1	704.5	508.6
	2004	23.7	26.1	45.6	6.1	20.1	596.3	516.2
	2005	30.2	32.1	45.3	4.8	25.0	749.1	487.5

TMN—total mineralisation of nitrogen (mg NH<sub>4</sub><sup>+</sup>-N kg<sup>-1</sup> 14 days<sup>-1</sup>)

NIT – nitrification rate (mg NO<sub>3</sub><sup>-</sup>-N kg<sup>-1</sup> 14 days<sup>-1</sup>)

C<sub>ox</sub>, N<sub>t</sub> as g kg<sup>-1</sup>

P, K, Mg as mg kg<sup>-1</sup>

The botanical composition was also influenced by folding. The original sward was completely destroyed and the soil was barren at the freshly folded areas in 2003. However, the sward started regenerating very soon. At the area folded on 17 May 2003, ground cover was 40% after 30 days and 80% after 80 days when the animals were moved away. At the area folded on 5 July 2003, the sward regenerated more slowly (due to a period of dry weather) and full canopy was reached as late as in 2004. The non-folded sward was dominated by meadow species (*Agrostis capillaris*, *Hypericum maculatum*, *Centaurea phrygia*, *Alchemilla vulgaris*, *Trifolium pratense*), but the forage species (*Dactylis glomerata*, *Festuca pratensis*, *Trisetum flavescens*, *Trifolium repens*, *Taraxacum officinale*) expanded on the folded areas. In the second year however, the sward was largely infested with weed (*Cirsium arvense*, *Rumex obtusifolius*, *Heracleum sphondylium*) at the area folded on 17 May 2003. This situation indicates an inappropriate way of folding, namely a very high stocking rate and neglected sward management afterwards (cutting, grazing). After many years, a ruderal nitrophilous community (*Urtica dioica*, *Cirsium arvense*, *Heracleum sphondylium*) is still dominating at the long-term animal resting place and because the sward is not cut, the ruderalisation process continues.

In 2003, the increased content of mineral N, P, Mg and especially K in soil resulted in changes in the chemical composition of herbage at the recently folded areas as well as at the long-term animal resting place. The content of crude protein (CP), K and nitrates markedly increased in herbage (Table 3).

The chemical composition of adjacent surface waters did not deteriorate very much because these were rather far away from the folded area (the animal drinking place was 200 m below and a small lake was 200 m above the fold). The content of NH<sub>4</sub><sup>+</sup> was 0.06 – 0.71, NO<sub>3</sub><sup>-</sup> was 0.08 – 5.77 and PO<sub>4</sub><sup>3-</sup> was 0 – 0.05 mg l<sup>-1</sup>, respectively. However, ammonia emissions in the air markedly increased, especially during the summer months (Table 4).

Table 3. Chemical analysis of herbage – data averaged over 2003 - 2005

Sampling areas	Years	CP	NO <sub>3</sub> <sup>-</sup>	P	K	Mg
Non-folded control	2003	89.0	97.7	1.2	11.9	2.2
	2004	157.6	344.4	2.3	22.6	2.6
	2005	122.6	37.3	1.9	19.5	2.5
Folded on 5 July 2003	2003	222.8	4566.6	2.7	35.3	2.9
	2004	176.1	477.6	3.6	28.5	2.1
	2005	136.1	205.2	2.7	25.0	2.0
Folded on 17 May 2003	2003	170.5	4431.8	2.0	26.9	1.8
	2004	170.7	593.7	3.1	29.1	2.2
	2005	138.0	315.7	2.7	25.2	2.1
The animal resting place in 1987 - 89	2003	141.4	1802.7	2.7	27.8	2.2
	2004	175.8	1146.9	3.3	31.1	2.8
	2005	150.8	567.2	3.5	39.7	2.7

CP, P, K, Mg as g kg<sup>-1</sup> DMNO<sub>3</sub><sup>-</sup> as mg kg<sup>-1</sup> DM)Table 4. Emissions of NH<sub>3</sub> as μg m<sup>-3</sup>

Position of samplers	Sampling dates								
	2004						2005		
	19 May	17 June	15 July	13 Aug.	16 Sep.	19 Oct.	27 May	30 June	17 Aug.
Above the folded area	1.96	23.66	12.68	7.87	2.88	1.11	3.50	6.85	3.36
In the middle of the folded area	5.33	21.36	30.36	45.36	2.57	18.43	6.11	25.75	84.54
50 m below the folded area	-	54.79	61.89	79.88	2.64	22.57	4.64	9.43	73.20

## Conclusions

In the year of folding, TMN and NIT were stimulated as a result of excessive stocking rate and consequently, the accumulation of mineral N forms dominated by nitrates was high in soil. The ammonia content increased in the air, especially in the summer. The composition of surface waters was not affected. The new sward had established well in the year of folding already and grass species (*Dactylis glomerata*, *Festuca pratensis*, *Trisetum flavescens*) were dominant. In the second year however, weeds (*Cirsium arvense* a *Heracleum sphondylium*) invaded the sward as a result of over-folding and neglected management (cutting, grazing). Moreover, high contents of nitrates, CP and mainly K were found in herbage. The ruderal nitrophilous community with dominance of *Urtica dioica*, *Heracleum sphondylium* and *Cirsium arvense* is still prevailing at the old long-term resting place of animals where folding with sheep was applied more than 17 years ago.

## References

- Braun-Blanquet J. (1964) *Pflanzensoziologie. Grundzüge der Vegetationskunde*, Springer-Verlag Wien, 865 pp.
- Novak J., Cernusko K. and Tyr S. (1997) Regulacia burinových druhov herbicidmi v ruderalnom travnom poraste. In *Rostlinna výroba*, roc. 43, (9), 439 - 448
- Ondrasek L., Krajcovic V. and Seifert G. (2000) Environment pollution by mineral nitrogen in the zones of hygienic protection of drinking water resources under rough grazing and folding with sheep. *Zeshtyty problemowe popstepow nauk rolniczych*, 2000, 472, 565-572.
- Opitz V. and Boberfeld W. (1994) *Grünlandlehre*. Verlag Eugen Ulmer, Stuttgart, 336 pp.

## **Analysis of a set of indicators to assess pastoral ecosystems utilised at different level**

Messeri A., Staglianò S., Pazzi G. and Argenti G.

*Department of Agronomy and Land Management, University of Florence, P.le Cascine 18, 50144 Firenze, Italy*

### **Abstract**

In Italy, such as in other parts of Europe, the progressive reduction of pastoral activity and of agricultural practices caused remarkable changes on floristic composition of several herbaceous association. This is especially clear in marginal mountain areas, both on the Alpine and on the Apennines chains. Modifications of the herbaceous components affect, in the long period, the whole ecosystem and macroscopically also the landscape. The passage from intensive to extensive forms of pasture exploitation without an appropriate planning causes the formation of vegetal associations characterised by oligotrophic species (like *Brachypodium* sp.) and by a remarkable number of shrubby species. In this study, conducted during the whole vegetative season in a mountain area in Tuscany (Central Italy), five nearby sites characterised by the same environmental conditions but with a different gradient of utilisation were identified. In each site the degree of evolution of vegetal communities has been evaluated through the collection of a series of biological and ecophysiological indicators, such as botanical composition and some characteristics of litter (thickness and weight). Results showed high difference in some studied parameters that can be properly used to predict the changes in the environment and to create a set of indicators that can be used as management tools.

Keywords: botanical composition, pastures, utilisation, litter

### **Introduction**

The reduction and the progressive extensification of pastoral activities determine deep modifications in natural herbaceous vegetations. This phenomenon is particularly clear in marginal areas, which are the firsts to be abandoned in favour of more productive ones. However, the dynamics of vegetation towards climax phase very rarely leads to the taking over of the wood in short times. In the majority of the situations the evolutive dynamics seems very uncertain (Tappeiner and Cernusca, 1993) especially where the pastoral activity, even if with a strong reduction, is made in an extensive way, without a spatial and temporal plan of the exploitation of the resources. Both in the Alps and in the Apennines there are remarkable examples of pastoral areas colonized by oligotrophic species, such as those belonging to genus *Brachypodium*, and by shrubs, with a consequent reduction of pastoral value and floristic variety of the canopy. Thus, it is clear the necessity to foresee these situations to avoid extreme degradation of the environment and to know the right moment for a productive and an ecological recovery of these areas. For these reasons a study was carried out in order to assess the changes in vegetation in relation to reduced utilisation and to evaluate some parameters that can easily be affected by level of exploitation.

## Materials and methods

The place of the study is located on Italian North Apennines, in the area of Mugello (Tuscany), at an height of about 700 m a.s.l., where 5 sites have been individuated. They presented the same environmental conditions but different level of utilisation and so a different grade of settlement of oligotrophic and shrubby species was observed. Type of resources varied from a natural grassland mowed once a year (site 1) to a pasture abandoned more than 30 years ago (site 5). Sites 2, 3 and 4 presented an intermediate level of utilisation mainly constituted by animal grazing with a very low and irregular stocking rate.

In each site 2 sample areas of 100 m<sup>2</sup> (25 x 4) were identified. Inside them a series of vegetational analysis has been made and repeated in spring, summer and autumn). To assess the vegetation of the places, for each site and for each relief time, the botanical composition has been calculated through linear analysis according to Daget and Poissonet method (Daget and Poissonet, 1969), with 25m transect and 50 samples along the line. The floristic biodiversity has been evaluated trough Shannon index (Ludwig and Reynolds, 1988). Moreover, some physical characteristics of the litter have been measured, such as thickness, fresh weight, dry weight and density, by taking three random samples for each time of data collection previously defined from a sample area of 625 cm<sup>2</sup> wide (25 x 25 cm). Samples collection has been made with previous cut of the all actual green phytomass and the samples, preserved in plastic bags to prevent humidity losses, have been weighed in laboratory with analytical balance to determine the fresh weight and consequently dried in 60° C stove for 48 hours up to the getting of a constant weight (dry weight).

Data have been analyzed with ANOVA using Tukey test to make all pairwise comparisons among treatments.

## Results and discussion

Botanical data showed the presence of three dominant grasses species: *Brachypodium genuense*, *Bromus erectus* and *Festuca gr. rubra* that were present in all sites. Table 1 reports average specific contributions (SC) of these species and the average values of the Shannon Index for each of the 5 studied sites.

Table 1. Specific contributions (SC %) of the dominant grasses species and Shannon index (H') for the studied sites (average of three period of data collection)

Site	<i>Brachypodium genuense</i>	<i>Bromus erectus</i>	<i>Festuca gr. rubra</i>	H'
1	7.4 b	15.0 ab	5.3 ns	2.88 ab
2	8.7 b	16.6 a	13.2 ns	2.67 bc
3	13.8 ab	12.3 ab	5.9 ns	2.72 abc
4	13.6 ab	8.3 b	7.1 ns	2.96 a
5	19.4 a	9.5 b	10.3 ns	2.46 c

Data in a column followed by the same letter are not significantly different for p<0.05 (Tukey test)

Observing the Table we can note that the SC of *Brachypodium genuense* tends to increase in a remarkable way in place 5, with a highly significant difference in comparison with the sites 1 and 2 while there are not substantial variations among the first four places. As to *Bromus erectus* we can highlight significant differences comparing the second place with the places 4 and 5 and so confirming the trend to the decrease of the SC values in the areas characterised by a reduced level of exploitation. *Festuca gr. rubra*, in opposite trend to other grasses, seems not to benefit by the mowing and the grazing, not showing statistically significant differences among the places. The trend of the grade of biodiversity is very noTable too and we can

observe from the analysis of the variance that some differences emerge among Shannon index values calculated inside the studied test areas. Data show that higher values are present in places 4, 1 and 2, while lower value is recorded in place 5, with a high significance of the test in the comparison of the means between the first and the last place. So we can suppose that the floristic diversity of the canopy does not suffer substantial variations during the first phases of reduction of the intensity of utilisation on the resource, but then, after a temporary increase determined by the colonization of new shrubby species, there is a noticeable simplification of the canopy, testified by a strong decrease of the Shannon index value to 2,46 in site 5. The highest value of biodiversity examined in place 4 is probably due to a particular situation of undergrazing with a mosaic vegetation, not examined in other places, characterised by a mixture among areas with high presence of infesting and shrubby species (particularly *Rubus* sp., *Crataegus monogyna* and *Rosa canina*) and parts of pasture not yet grazed, so there are both species indicative of evident undergrazing and species of a still very good pastoral value, as *Dactylis glomerata* and *Lotus corniculatus*.

The reduction of intensity of utilisation on the resource causes a high increase in the presence of highly competitive species as *Brachypodium* that thanks to its rapidity of removing of nutritional components when leaves die in the roots and rhizomes (Werner, 1986), to the competitiveness opposite to the light (Mitchley, 1988) and to the large production of litter, tends to overhang other species and to become the exclusive or the dominant one. This is confirmed by the inverse proportional ratio between the two most represented grasses, with a gradual passage from grassland dominated by *Bromus erectus* (place 1) to abandoned pastures dominated by *Brachypodium genuense* (place 5).

The extensification of the pastoral activities and the consequent reduction of the pressure on the herbaceous resource causes, with the passing of the vegetative seasons, an increase of the phytomass and the accumulation of necromass and litter at the ground level (Louault, 1999). Concerning this, some physical characteristics of the litter have been examined to find out possible correlation with the level of exploitation, the grade of invasion of oligotrophic and shrubby species and the floristic richness. The sites with a reduced level of exploitation and so with a higher SC of oligotrophic species present a great amount of litter, mostly in terms of thickness (Figure 1), with value in place 5 which is about ten times higher than those of place 1 and 2, with an analysis of the variance that highlights significance differences among the means.

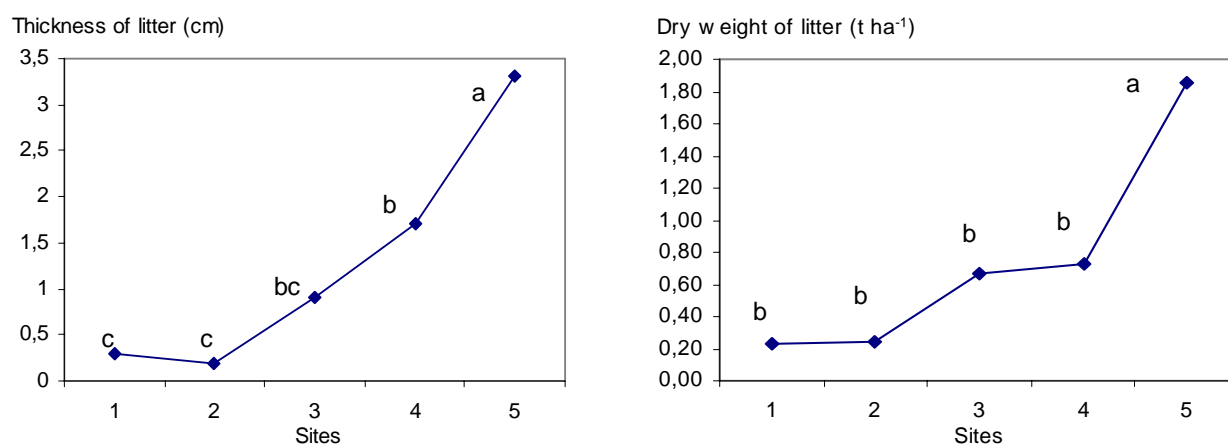

Figure 1. Thickness (cm) and dry weight (t ha<sup>-1</sup>) of the litter for the studied sites. Values with the same letter are not significantly different for  $p < 0.05$  (Tukey test)

In terms of dry weight we do not note statistically significant variations among the firsts four places while we observe a high increase of the litter mass in the not exploited area. In site 5 the value of 1,86 t ha<sup>-1</sup> of litter is reached in comparison to 0.24 t ha<sup>-1</sup> of site 1. This large accumulation of organic substance, mostly decomposed at ground level, prevents the direct contact between seeds and soil and it makes difficult the germination and the settlement of new species. The excessive accumulation of litter causes high changes in the microclimate in the superficial layers of the canopy, reducing the level of the light that can penetrates (Aerts, 1999). Thus, it seems in this contest that this is one of the main reasons which determine a floristic reduction and an unsuccessful evolution of the pasture towards more complex coenosis.

## Conclusions

This study shows the remarkable changes that occur in vegetation in relation to different management practices on natural herbaceous resources. We can state that the different gradient of exploitation inside the 5 analysed places is highly reflected on the botanical composition, on the floristic diversity of the canopy and the biodiversity of the whole studied landscape. The litter, with the botanical composition, seems to be a good parameter, simply collectable and analysable, to foresee the vegetational evolution of a herbaceous coenosis and the changes in the environment, even if more studies are needed in order to create a more complex set of indicators that can be used as management tools to make a correct management of the pastoral areas.

## References

- Aerts R. (1999) Interspecific competition in natural plant communities: mechanism, trade-offs and plant-soil feedbacks. *J. Exp. Bot.*, 50, 29-37.
- Daget P. and Poissonet J. (1969) Analyse phytologique des prairies. CNRS, Cepe de Montpellier, document, 50, 67 pp.
- Louault F. (1999) Dynamics of dead and living plant material in grassland under non- intensive use. *Proceedings of 6<sup>th</sup> Int Rangeland Congress*, 19-23 July, 1999, Townville, 274-275.
- Ludwig J. A. and Reynolds J.F. (1988) Statistical ecology: a primer on methoda and computing. John Willey and sons, New York, 27, 7pp.
- Mitchley J. (1988) Control of relative Abundance of Perennials in Chalk grassland in Southern England, II. Vertical Canopy Structure. *Journal of Ecology*, 76, 341-350.
- Tappeiner U. and Cernusca A. (1993) Rapporti dinamici fra pascoli abbandonati e bosco. *Comunicazione di Ricerca ISAFSA*, 1, 67-80.
- Werner W. (1986) Biomass development and nitrogen movement of hemicryptophytes of various growth forms in the field and in cultures. *Dissertation Abstract International*, 47, 4.

# The impact of grassland management systems on a *Festuca rubra* mountain pasture

Sima N. and Rotar I.

University of Agricultural Sciences and Veterinary Medicine, 3400 Cluj Napoca, Romania

## Abstract

The purpose of this research was to identify some technological variants with low level of external inputs (fertilization, liming) which can assure the sustainable production of forages on *Festuca rubra* mountain pastures (R 3803 habitat, Nature 2000-6510) from Cindrel Mountains (Romania). Thus, starting in 1998, the impact of management (N / P / K fertilization; P / K fertilization; sheep folding; over sowing with *Trifolium repens*; liming; cutting) on some soil chemical features, on nutritional status with N / P / K of plants, on floristic composition of sward and on forage production has been studied. Moderate chemical fertilization (100 / 22 / 83 kg N / P / K ha<sup>-1</sup> year<sup>-1</sup>) and liming soil influenced positively the soil chemical features, the nutritional status of plants, the level of forage yields and the organic carbon content of soil. The influence of amendments on the floristic composition of sward is obviously just after eight years.

Keywords: *Festuca rubra*, management, floristic composition, yield, soil organic carbon

## Introduction

In Romania, pastures represent about 33% of the agricultural land and 51% of the arable land; 25% of the 4.9 10<sup>6</sup> ha of pastures are placed in the mountain area, their status being partly influenced by soil acidity. Soil erosion and soil acidity are the most important restrictive factors. Because of this reason the improvement of some soil chemical features (pH, soil supply status with mobile P and K, *et al.*) represents an important solution for the sustainable forage production in the mountain area.

## Materials and methods

The research was conducted on a *Festuca rubra* mountain pasture from Cindrel Mountains at 1348 m a.s.l. The climate in this region is characterized by an annual mean temperature of 4.5 °C and an annual rainfall over 900 mm. The experiment's area included a Dystric cambisol type of soil, with an acid pH and a low level of mobile P and K supply. The experiment was organized in randomized blocks with four replicates and included the following treatments: 1) *Festuca rubra* – *Agrostis capillaris* natural pasture as control; 2) 100 / 22 / 83 kg N / P / K ha<sup>-1</sup> y<sup>-1</sup>; 3) sheep folding during 3 nights (one sheep m<sup>-2</sup>); 4) 0 / 22 / 83 kg N / P / K ha<sup>-1</sup> y<sup>-1</sup> + over sowing with *Trifolium repens* (at the beginning of the experiment in 1998); 5) 0 / 22 / 83 kg N / P / K ha<sup>-1</sup> y<sup>-1</sup>. The variants were combined without liming (V1-V5) and with liming (V1'-V5' one receiving 5.5 t ha<sup>-1</sup> CaCO<sub>3</sub>). The botanical composition was determined by Braun-Blanquet method and the yield was determined by weighing. The nutritional indicators (IN) of plants for nitrogen (INN), phosphorus (INP) and potassium (INK) were determined through the relations elaborated by Lemaire (1997) and Balent *et al.* (1997), which for N, P, K represent the content of plant in respective element. The statistical interpretation of results was realized by using a Duncan test.

## Results and discussions

As can be observed from Table 1 the grasses were dominant during 1998-2002 in absence of liming. *Festuca rubra* occupied the first place in the sward of all treatments. The domination of *Festuca rubra* indicates a poor soil with low levels of N, P, K.

Table 1. The influence of treatments on the sward and the most important modifications of species ratio: *Festuca rubra* (F.r.) and *Agrostis capillaris* (A.c.) – 1998, 2002 and 2006

Treatments	without liming			liming		
	V1 - natural pasture control			V1' - natural pasture		
Year	1998	2002	2006	1998	2002	2006
Floristic composition %						
Total grasses (%)	70 F.r. 60; A.c. 5;	65	70	70 F.r. 60; A.c. 5;	70	75 F.r. 15; A.c. 60;
Legumes (%)	+	-	-	+	+	+
Other botanical families (%)	20	5	5	15	5	5
Treatments	V2 - 100 / 22 / 83 kg N / P / K			V2' - 100 / 22 / 83 kg N / P / K		
Floristic composition %						
Total grasses (%)	85 F.r. 65; A.c. 15;	85	100 F.r. 25; A.c. 75	85 F.r. 60; A.c. 15;	85 F.r. 20; A.c. 65	95 F.r. 5 A.c. 90
Legumes (%)	+	+	-	+	+	+
Other botanical families (%)	15	10	+	15	10	5
Treatments	V3 - sheep folding			V3' - sheep folding		
Floristic composition %						
Total grasses (%)	65	50	70	70 F.r. 55; A.c. 10;	70	65
Legumes (%)	+	+	+	+	5	15
Other botanical families (%)	15	10	5	20	10	10
Treatments	V4 - 0 / 22 / 83 kg N / P / K + <i>T. repens</i>			V4' - 0 / 22 / 83 kg N / P / K + <i>T. repens</i>		
Floristic composition %						
Total grasses (%)	70	70	85	80	20 F.r. 5; A.c. 15;	85
Legumes (%)	+	15	+	+	75	5
Other botanical families (%)	15	5	+	15	+	5
Treatments	V5 - 0 / 22 / 83 kg N / P / K			V5' - 0 / 22 / 83 kg N / P / K		
Floristic composition %						
Total grasses (%)	70%	70%	85%	75%	80%	75% F.r. 20%; A.c. 55%;
Legumes (%)	+	5%	5%	+	5	15
Other botanical families (%)	15	+	5	15	10	5

+ indicates a ratio value under 1% in the sward;

Where the percentage values for F.r. and A.c. are not indicated, the ratio is plainly dominant for F.r. while the A.c. proportion is under 5%.

Proofs in this meaning are the results of soil analyses (Table 2) and the small values of the plant nutritional indicators obtained in 2002 (Table 3).



The soil analyses indicated for almost all of the variants a poor soil with low level of mobile P (excepting V2' with average supply). Mineral fertilized variants placed on liming soil (V4' and V5') recorded upper values of mobile P in soil in comparison with the similar variants placed on without liming soil.

The soil analyses indicated a poor soil with low level of mobile K on without liming soil for the majority of treatments (excepting V4 with an average supply). The soil content in mobile K was average in case of mineral fertilized variants (2', 4', 5') placed on liming soil.

The nutritional status of plants in N, P, K, expressed by nutritional indicator's values, in case of without liming soil, was poor regardless of the applied treatment (Table 3).

Table 2. Mobile P and K content of soil as influenced by used inputs.– Measured in 2002

<b>P<sub>AL</sub> ppm</b>	<b>K<sub>AL</sub> ppm</b>		<b>Treatment</b>		<b>P<sub>AL</sub> ppm</b>	<b>K<sub>AL</sub> ppm</b>
21	120	without liming	1 control	with liming	20	116
20	156		2 100/22/83 N/P/K		27	179
18	130		3 sheep folding		19	134
14	200		4 0/22/83 N/P/K + oversowing <i>T.repens</i>		23	223
16	158		5 0/22/83 N/P/K		22	221

A nutritional status of plants near by those normal (IN-80) was recorded just for K and just for the variants fertilized with P / K (V4-75 and V5-74). The nutrition of plants with N, P, K was poor for the majority of variants placed on liming soil. As an exception V5' variant – 0 / 22 / 83 N / P / K can be remarked, which for a normal nutrition of plants with P and K (INP-80 and INK-85) was recorded. More near values among INN, INP, INK and by normal (IN-80) was observed in case of V2' and V4' variants.

Table 3. The nutritional indicators with N, P, K – 2002 year, I<sup>st</sup> cycle

<b>INN</b>	<b>INP</b>	<b>INK</b>		<b>Treatment</b>		<b>INN</b>	<b>INP</b>	<b>INK</b>
53	60	34	without liming	1 control	with liming	46	54	34
63	55	69		2 100/22/83 N/P/K		78	66	69
42	58	25		3 sheep folding		48	71	35
42	56	75		4 0/22/83 N/P/K + oversowing <i>T.repens</i>		56	75	65
38	70	74		5 0/22/83 N/P/K		47	80	85

- INN, INP, INK values included between 80 – 120 indicates a normal nutrition of plants with N, P, K;
- INN, INP, INK values included between 50 – 80 indicates a poor nutrition of plants with N, P, K;
- INN, INP, INK values under 50 indicates a severe poor nutrition of plants with N, P, K;
- INN, INP, INK values over 120 indicates an excessive nutrition of plants with N, P, K.

The increase of mobile K content of soil and the improvement of nutritional status of plants for this element as influenced by annual fertilization (V5) determined in 2002 the increase of legumes ratio in the sward with 5% (Table 1). The average mobile K content of soil and over sowing (V4) determined in 2002 the increase of legumes ratio with 15%.

A strong influence of some soil chemical feature's modification on the floristic composition was observed in 2002. An average soil content in mobile P and K determined in V2' an increase of *A. capillaris* ratio (65%), a more valuable specie than *F. rubra*, which became dominant (Table 1). An average K content of soil, respectively a P content of soil very closed

by average (Table 2), determined in V4' an increase of legumes ratio (*T. repens*), which represent 75% from the sward (Table 1).

Table 4: The influence of N, P, K fertilization combined with liming on dry matter yield ( $t\ ha^{-1}$ ) and organic carbon content of soil (SOC %) - 2006

Variant	Treatments	DM yield $t\ ha^{-1}$	Var.	Treatments	SOC (%)
V1	natural pasture control	2.70 <sup>A</sup>	V1	natural pasture control	5.70 <sup>A</sup>
V3	sheep folding	3.00 <sup>A</sup>	V5'	0/22/83 N/P/K / liming	6.17 <sup>AB</sup>
V1'	natural pasture / liming	3.26 <sup>AB</sup>	V1'	natural pasture / liming	6.25 <sup>AB</sup>
V3'	sheep folding / liming	3.41 <sup>AB</sup>	V3'	sheep folding / liming	6.32 <sup>AB</sup>
V5	0/22/83 N/P/K	3.74 <sup>ABC</sup>	V3	sheep folding	6.33 <sup>AB</sup>
V4	0/22/83 N/P/K + T.repens	4.49 <sup>BCD</sup>	V4'	0/22/83 N/P/K + T.repens / liming	6.36 <sup>AB</sup>
V5'	0/22/83 N/P/K / liming	4.99 <sup>CDE</sup>	V4	0/22/83 N/P/K + T.repens	6.38 <sup>AB</sup>
V2	100/22/83 N/P/K	5.32 <sup>DE</sup>	V5	0/22/83 N/P/K	6.39 <sup>AB</sup>
V4'	0/22/83 N/P/K + T.repens / liming	6.02 <sup>EF</sup>	V2	100/22/83 N/P/K	6.41 <sup>B</sup>
V2'	100/22/83 N/P/K / liming	7.25 <sup>F</sup>	V2'	100/22/83 N/P/K / liming	6.45 <sup>B</sup>

Different superscript indicates significant difference ( $p < 0.05$ )

In 2006 on without liming soil the most important modification of sward floristic composition was recorded in V2, which for *A. capillaris* had a ratio about 75% (Table 1). *Agrostis capillaris* specie became dominant on liming soil representing 60% in V1', 90% in V2' and 55% in V5'. The floristic composition analyze, in 2006, indicated an increase of legumes ratio in the sward of V3' (with 10%) and V5' (with 10%) treatments, respectively a very strong decrease of them in V4' (with 70%) treatment, in comparison with 2002.

The best forage yield in 2006 was obtained in V2' variant followed by V4' both on liming soil. Yield efficiencies obtained through the use of chemical fertilizers were significant in comparison with experimental control and the result of each treatment differentiated from the others (Table 4).

The organic fertilization in the absence of liming determined insignificant yield efficiencies.

The improvement of pasture management determined the increase of yield, without to record compulsory an identical strong increase of organic carbon content of soil (Table 4).

## Conclusion

The moderate chemical fertilization and liming (V2' and V5') influenced positively the soil chemical features, the plants nutritional status and the level of forage yields. The effect of over sowing was maxim in the fifth year. The effect of annual organic fertilization (sheep folding) on the presence of valuable grasses and legumes in the sward was positive but slowly. Moderate fertilization with nitrogen favored the organic carbon accumulation in soil.

## Acknowledgments

This work was realized with help of the National University Research Council – Romania.

## References

- Balent G., Duru M., Gibon Annick, Magda D. and Theau J. P. (1997) Outils de diagnostic agro - écologique et guide pour leur utilisation. INRA, Toulouse
- Cardaşol V., Daniliuc D., Pop M., Razec I. and Brezan I. (1987) Creşterea potenţialului productiv al pajiştilor naturale prin amendare şi fertilizare. Revista Zootehnie şi Medicină Veterinară, nr. 4, p.
- Lemaire G. (1997) Diagnosis of the nitrogen status in crops. Printed in Germany.

# Changes in habitats and meadow communities in relation to the soil type and moisture

Kozłowska T. and Kwiecień R.

*Institute for Land Reclamation and Grassland Farming at Falenty, 05-090 Raszyn, Poland*

## Abstract

Studies were carried out in the years 1991-1999 in meadows situated on mineral and organic soils. Type of the soil, its biological activity, ground water level, meadow communities and groups of meadow habitats according to their moisture were determined in 31 representative sites. In the beginning of the 1990s conservation of particular reclamation facilities on grasslands was abandoned. Consequently, ground water Table and moisture increased in most meadow habitats located on organic soils. Nitrifying activity depended on the type of soil and moisture. In the beginning of this study analysed sites were split into four groups of habitat moisture, finally divided into six groups. Species typical for the latter (mainly sedges) appeared in meadow communities.

**Keywords:** nitrifying activity, moisture numbers of meadow communities, changes in habitat

## Introduction

There are c. 3.5 million ha of permanent grasslands in Poland. In the 1950s to 1970s most of grasslands were reclaimed and managed and all were relatively well used and fertilised. They were overgrown by multi-species communities of the class *Molinio-Arrhenatheretea*. In the beginning of the 1990s conservation of particular reclamation facilities was abandoned. Consequently, moisture increased in part of meadows on organic soils situated at the edge or in the spring stretches of river valleys. situated at the edge or in the spring stretches of river valleys. Meadows on mineral soils usually occur in the middle part of valleys, on local elevations and near conserved basic ditches. Meadows on mineral soils usually occur in the middle part of valleys, on local elevations.

The study was aimed at analysing diverse response of meadow habitats differing in soils, their moisture and nitrifying activity to abandoned conservation of particular reclamation facilities and altered habitat conditions.

## The study area and methods

The study was carried out in central Poland during 1991-1999 on reclaimed meadows situated in river valleys. Eleven representative sites on mineral soils and 20 on organic soils were selected for this study. The soil (taken from soil pits), ground water level (in spring and during the I and II cut) and botanic composition (with the Klapp's method) were analysed. Soil samples were collected from 0-20 cm soil layer. Biological activity was determined in fresh soil samples. The following tests for nitrifying activity were using: momentary content of N-NO<sub>3</sub> in the non-vegetation period, N-NO<sub>3</sub> content after aerobic incubation and an increment of N-NO<sub>3</sub> as a result of aerobic incubation (Frąckowiak, Wesołowski, Durkowski, 1986). Moisture of meadow communities was calculated based on their plant species indicative values (Klapp 1965, Oświt 1994).

## Results and discussion

Dry, periodically wetted habitats were found only on very light mineral soils underlined with sand (tab. 1) like moorshy (Mi), moorshous (Me) and alluvial soils (F). Sites of fresh habitats occurred on more compact mineral soils (moorshous – Me, deluvial – E and black earths – D) and on organic soils (mineral -moorsh – Mr and peat – moorsh – Mt). Moist habitats were mainly represented by sites on mineral-organic soils (Mr) and one on mineral soils (black earths – D). Heavily moist and wet habitats were found on organic soils (Mr, Mt). All meadows on organic soils were the post-paludic meadows of various degrees of decomposition and organic layer thickness. Increasing moisture in habitats was accompanied by decreasing bulk density of soils as a result of higher content of organic matter.

Table 1. Bulk density ( $\text{g cm}^{-3}$ ) and nitrifying activity  $\text{N-NO}_3$  (momentary, after incubation and increase) during the non-vegetation period ( $\text{mg dcm}^{-3}$ ) in soil layer 0-20 cm in 1994 year

Humidity habitat	Number of sites	Symbol of soil	Bulk density ( $\text{g cm}^{-3}$ )	Nitrifying activity $\text{N-NO}_3$ ( $\text{mg dcm}^{-3}$ )		
				momentary	after incubation	Increase
I. Dry-periodically moist	4	Mi, Me, F	1,31	14,7	38,3	23,6
II. Fresh:						
mineral soil	6	Me, E, D	1,06	29,9	61,2	31,3
organic soil	7	Mr, Mt	0,68	32,0	105,9	73,9
III. Moist:						
mineral soil	1	D	1,40	22,2	67,3	45,1
organic soil	7	Mr, Mt	0,43	29,0	98,1	69,1
IV. Heavily moist and wet	6	Mr, Mt	0,24	18,3	62,3	44,0

Ground water levels were differentiated in studied habitats (Figure 1). In sites from the same group of habitats the ground water level was always higher in organic than in mineral soils.

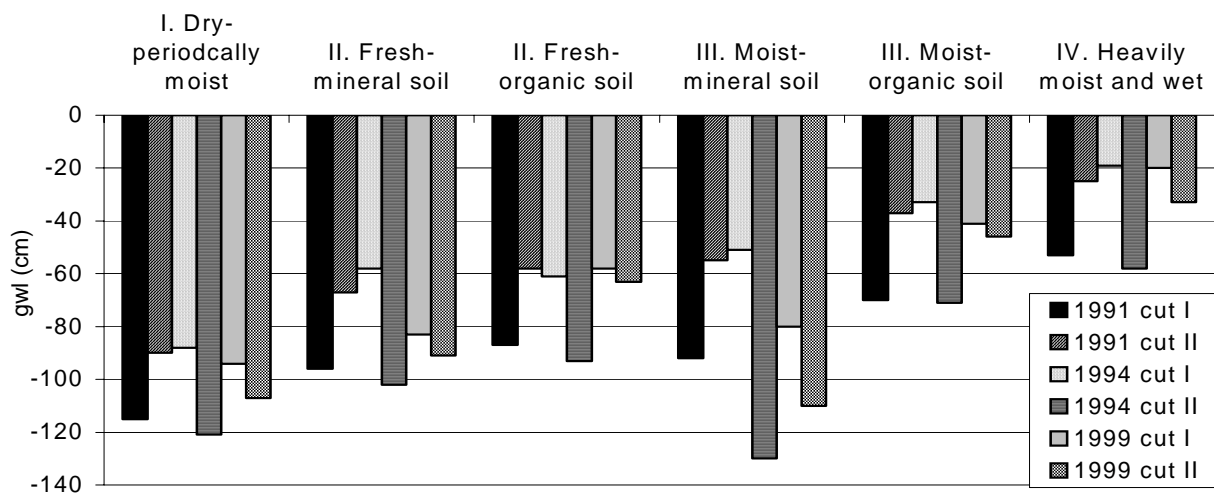

Figure 1 Mean groundwater level (in cm) in four humidity habitat groups in 1991, 1994, 1999

The levels were lowest in all sites during dry periods (1991 – I cut, 1994 – II cut, 1999 – II cut). In sites of the II and III group the ground water level decreased to 46 – 87 cm in organic soils and to less than 90 cm in mineral soils. During other periods the ground water levels were higher in sites of the II and III group (33-61 cm in organic soils and 51 – 83 cm in mineral soils). In sites of group IV the ground water level decreased to 58 cm in 1994 but remained high in the next years inundating the root zone and often flooding.

Biological activity of soils was estimated with nitrifying bacteria whose ecologic demands are similar to those of higher plants. All types of nitrifying activity were highest in sites of group II and IV in organic soils and slightly lower in mineral soils of these habitats (Table 1). The lowest nitrifying activity was found in dry habitat I. In heavily moist and wet habitat IV momentary activity was low, similarly to soils in dry habitats, and N-NO<sub>3</sub> content after incubation and the increments of N-NO<sub>3</sub> were similar to respective values in mineral soils of habitats from groups II and III. High (habitat IV) as well as low (habitat I) soil moisture restricted momentary nitrifying activity. High contents of N-NO<sub>3</sub> after incubation and high N-NO<sub>3</sub> increments in soils of habitat IV suggest, however, a possibility of increasing the nitrifying activity in this habitat after a decline of ground water levels. Nitrifying activity depended mainly on moisture and the type of soil.

Reclaimed and agriculturally used grasslands were chiefly overgrown by grass communities, sometimes by herb-grass or sedge grass communities usually of the class *Molinio-Arrhenatheretea*. Abandoning conservation of reclamation facilities and less intensive grassland management were followed by changes in soil moisture and species structure of meadow communities. Contribution of superior and fine quality grasses (and of all grasses) decreased to the benefit of medium and inferior grasses in all communities irrespective of the habitat (Table 2). The share of eutrophic species like *Dactylis glomerata*, *Alopecurus pratensis* and *Poa pratensis* decreased in majority of habitats. Meadow communities on organic soils (habitats III and IV) showed a low percentage of superior and fine quality grasses in the beginning of the study. At the end, the share of medium and inferior grasses (mainly of *Deschampsia caespitosa* which expanded 5-fold in habitat III) increased by c.70%. The share of legumes was small (1-2%) but increased during the study period to 1-4% on mineral soils. An increase of moisture in sites from the IV group caused the retreat of legumes and increased the contribution of sedges by 39%. Extensive management enriched many meadow communities in the number of species (from 2 to 8). Low nutrient content in soils favours the occurrence of more species (Janssens *et al.* 1997). Species richness decreased only in habitat III on organic soil in a community dominated by *Deschampsia caespitosa*. Most sTable were the communities in fresh habitat II on both mineral and organic soils.

Table 2. Changes in plant communities of different habitat humidity groups in the years 1991-1999 (%)

Plant groups and species	Humidity habitat											
	I dry-periodically moist soil		II fresh soil		II fresh soil		III moist soil		III moist soil		IV heavily moist and wet soil	
	mineral	organic	mineral	organic	mineral	organic	mineral	organic	mineral	organic	mineral	organic
	1991	1999	1991	1999	1991	1999	1991	1999	1991	1999	1991	1999
Superior and fine quality grasses	41	30	76	58	74	54	72	47	44	32	38	14
<i>Alopecurus pratensis</i>	10	4	13	12	21	12	15	6	10	8	4	1
<i>Poa pratensis</i>	20	15	24	22	30	21	20	14	19	11	19	4
Medium and inferior	31	38	11	21	12	26	18	31	24	41	15	26
<i>Deschampsia caespitosa</i>	-	-	+	2	2	3	1	7	5	25	3	14
Total grasses	72	68	87	79	86	80	90	78	68	73	53	40
<b>Legumes</b>	1	2	1	3	1	1	1	5	2	2	2	0
Sedges	1	2	-	r	r	1	1	1	8	9	28	39
Herbs and weeds	26	28	12	18	13	18	8	16	22	16	17	21

Four groups of habitats were distinguished in the beginning of the study depending on moisture numbers of meadow communities (Figure 2). In most communities (55%) growing on organic soils the moisture numbers increased and consequently fell into more humid group of habitats. In only one site the number decreased and in 40% of sites it remained constant. Continuous elevation of the ground water level in organic soils (mainly in group IV) caused

the appearance of additional two groups of habitats at the end of the study: heavily wet and paludifying (V) and occasionally drying marshes (VI). In the beginning of the study these meadows were classified to group IV. An increase of moisture and a switch of habitats to more humid group took place in part of meadows of the III group on organic soils. Communities growing on mineral soils were more stable, 64% of them did not change their moisture group, drying and a switch to drier group was noted in 27% of sites and only in one – to more humid group. The increase of meadow moisture on organic soils was found in sites situated in spring stretches and at the edge of river valleys and in more compact mineral soils.

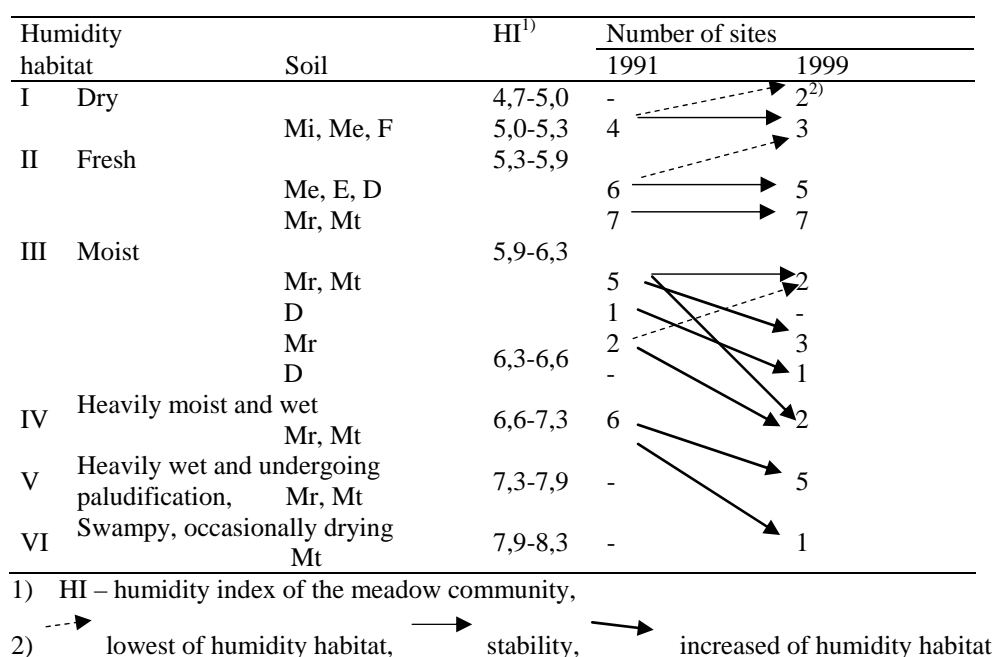

Figure 2. Changes in the type of humidity habitat of studied sites in 1991-1999

## Conclusions

Cessation of the conservation of reclamation facilities resulted in an increase of moisture in part of post-paludic meadows situated in spring stretches and at the edges of river valleys. Under similar moisture conditions all types of nitrifying activities were higher in organic than in mineral soils. Higher moisture limited biological activity of soils (momentary nitrification) and enabled to form wet and marshy habitats. Habitats on mineral soils situated on local elevations tended to become drier. Extensive use decreased the contribution of superior and fine grasses in the sward but increased the number of species in plant communities.

## References

- Frąckowiak H., Wesołowski P., Durkowski T. (1986) Wpływ zabiegów agromelioracyjnych na zmiany biologicznej aktywności gleb mineralno-murszowych i plonowanie użytków zielonych. *Rocz. Nauk Rol.* Ser. F t. 81 z. 2 p. 37-49.
- Janssens F. (1997) Relationship between soil nutrients and plant diversity in grasslands; definition of limits for maintenance and the reconstruction of species-rich communities. In: *Proc. Inter.Occasional Symp. EGF*, Warszawa-Lomża vol. 2 s. 315-322.
- Klapp E. (1965) *Grunlandvegetation und Standort*. Berlin/Hamburg, pp. 384.
- Oświt J. (1994) Identification of humidity conditions in meadow sites, using vegetation index. In: *Taxonomy of hydrogenic soils and sites used in Poland*. Bibl. Wiad. IMUZ 84, p. 101-130.

# Forecasting the development of plant diversity in grazed pastures: Possible with nutrient balances?

Wrage N.<sup>1</sup>, Şahin Demirbağ N.<sup>1,2</sup>, Röver K.-U.<sup>1</sup>, Hofmann M.<sup>1,3</sup> and Isselstein J.<sup>1</sup>

<sup>1</sup> *Georg-August-University Goettingen, Department for Crop Sciences, von-Siebold-Str. 8, 37075 Goettingen, Germany*

<sup>2</sup> *present address: University of Ankara, Faculty of Agriculture, Department of Field Crops, 06110 Dışkapı, Ankara, Turkey*

<sup>3</sup> *present address: Saechsische Landesanstalt für Landwirtschaft, Referat 64, Christgruen 13, 08543 Poehl, Germany*

## Abstract

Plant diversity in grasslands is influenced by the availability of nutrients. Nutrients in grazed pastures are patchily distributed. We tested the hypothesis that split plot balances for areas affected by dung (not grazed in the same year), urine (grazed), or grazing (no excretal input), are a tool allowing to forecast the development of plant diversity. For plots grazed with low or moderate intensity by Simmental cattle since 2002, split plot balances were calculated for the main plant nutrients N, P and K and predictions for plant diversity development made. These predictions were tested against the measured developments of biodiversity on the plots. First results indicate that split plot balances together with calculations of temporal dynamics of nutrient concentrations seem to allow meaningful predictions of the development of plant diversity on grazed grassland. This could help in forecasting the effect of management options on plant diversity.

Keywords: biodiversity, grazing, nutrients

## Introduction

Plant biodiversity develops in relation to several factors, among others the availability of nutrients (Critchley *et al.*, 2002; Janssens *et al.*, 1998). Conventional nutrient balances, e.g. soil surface balances, assume a uniform distribution of nutrient input and output. However, this is not realistic for grazed systems. Therefore, we calculated balances for different grazing areas: areas with cow pats (not grazed in the same year), areas with urine patches (grazed normally), and those without excreta (grazed normally). We investigated whether such split balances are a better basis for predicting the development of plant diversity in grazed pastures.

## Materials and methods

The basis of calculations was a permanent pasture experiment with steers that was started in 2002 within the framework of the EU project FORBIOBEN at the experimental farm of Goettingen University at Relliehausen, Solling, Germany (Röver, 2006; Sahin, 2005). Two treatments were compared: a moderately intensive grazing treatment with a target compressed sward height of 6 cm (MC, approximately 4 Simmental steers per hectare) and an extensive one with a target compressed sward height of 12 cm (LC, approximately 2 Simmental steers per hectare). Treatments were established in triplicate, the plot area being one hectare. The grazing season normally lasted about 180 days, from the beginning of May to the beginning of October.

'The animals' nutrient uptake was estimated from their energy requirement (Baker, 2004) and the energy supplied by the herbage (Schmidt *et al.*, 2004). The excretion of nitrogen (N), phosphorus (P) and potassium (K) with faeces or urine was calculated following a range of methods as fractions of the amounts of nutrients taken up or from literature data (Wrage *et al.*, in prep.). Data on the amount of nutrient deposition was obtained from the NLWKN (network of long-term deposition sampling stations in Lower Saxony, Germany). N fixation was estimated following the method by Weissbach (1995). The results of the spatial and temporal distribution of nutrients were compared with investigations of the botanical composition of the plots, measured on 10 subplots (1 m<sup>2</sup> each) per plot, three times per year (Sahin, 2005).

## Results and discussion

Soil surface balances showed for the first three years of the experiment for both treatments surpluses for N (35 to 83 kg N ha<sup>-1</sup> a<sup>-1</sup>), but deficits for P and K (0.3 to -6 kg P ha<sup>-1</sup> a<sup>-1</sup> and -25 to -36 kg K ha<sup>-1</sup> a<sup>-1</sup>, respectively). There were no significant differences between treatments. The split balances showed significant differences between pasture areas with cow pats, with urine patches and the grazed only area. When calculated per hectare, the largest N surpluses were found under cow pats (800 to 1180 kg N ha<sup>-1</sup> a<sup>-1</sup>), followed by urine patches (650 to 950 kg N ha<sup>-1</sup> a<sup>-1</sup>). The grazed areas had either N surpluses or deficits, depending on the surface cover of legumes (-40 to +30 kg N ha<sup>-1</sup> a<sup>-1</sup>). The picture was similar for K, but with largest surpluses under urine patches and a clear deficit in areas not affected by excreta (300 to 450 kg K ha<sup>-1</sup> a<sup>-1</sup> under cow pats, 970 to 1500 under urine patches and -30 to -150 kg K ha<sup>-1</sup> a<sup>-1</sup> for the rest of the area). Split balances for P were different from the other balances in that they were negative also for areas under urine patches (400 to 700 kg P ha<sup>-1</sup> a<sup>-1</sup> under cow pats, -14 to +5 under urine patches and -4 to -22 kg P ha<sup>-1</sup> a<sup>-1</sup> for the rest of the area). For split balances, there were significant differences between treatments, with both larger surpluses and larger deficits in more intensively grazed plots.

The similarity of the soil surface balances for the two treatments would suggest that the development of the vegetation should be similar, if other influences like selective grazing or treading are being neglected. In contrast with this, from the split balances, differences would be expected. For example, the area affected by excreta was larger on intensively grazed plots than on the others (Table 1). This would suggest a larger similarity on the more intensively grazed plots. Indeed, vegetation investigations showed a larger similarity (Bray-Curtis Index) between subplots on the more intensively grazed plots.

Table 1: Area covered by dung or urine per grazing season in percent of the total area (total area = 1 ha), calculated with minimum values from König (2002). The area affected by grazing was defined as the remaining pasture area where no excreta were deposited. MC: moderately intensive grazing, LC: lenient grazing

	Treatment	2002	2003	2004
Dung	MC	4.0	2.4	3.8
	LC	2.3	1.0	1.9
Urine	MC	10.1	6.1	9.6
	LC	5.9	2.5	4.8

Since both inputs and outputs were larger on intensively used plots and the time between excreta deposition events is shorter (Figure 1, after (Petersen *et al.*, 1956)), it is expected that the vegetation on these plots should develop more dynamically than on the extensively used plots. A first indication of this is a larger surface cover of r- and cr-strategists in more intensively grazed plots. This development will be checked by vegetation analyses over the coming years.



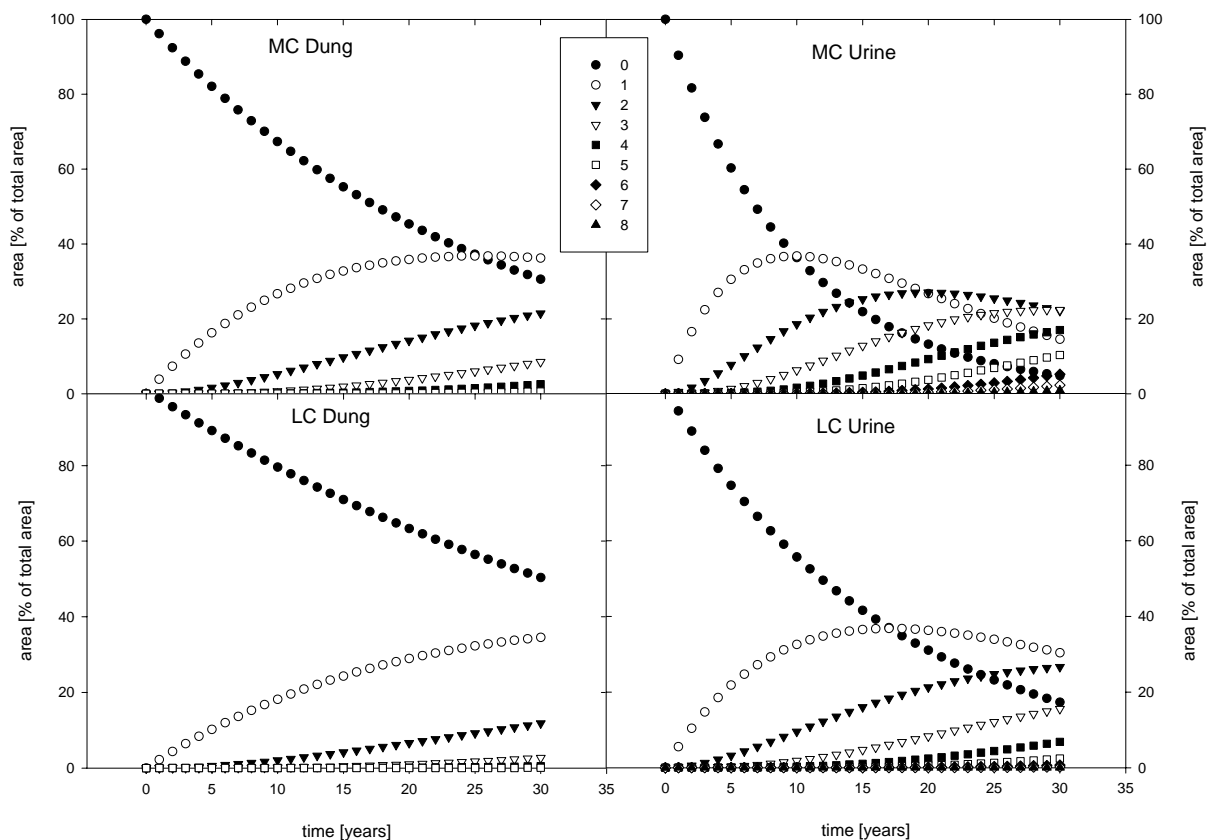

Figure 1: Temporal distribution of dung (left-hand side) and urine (right-hand side) on the pastures, depending on the grazing intensity (moderate intensity: upper half, low intensity: lower half), calculated after (Petersen *et al.*, 1956). Numbers in the legend describe the amount of excretion events affecting one spot.

Whether grazing leads to a decrease of P (in large areas but small amounts) as well as K and N (in small areas but larger amounts) depends on the grazing intensity as well as on the spatial distribution of excreta on the plots. Split balances for pasture areas with cow pats, urine patches or without excreta are better bases for making predictions on this and on the development of plant diversity than soil surface balances.

## Conclusions

Split plot nutrient balances combined with calculations of temporal dynamics of nutrient concentrations seem to allow meaningful predictions of the development of plant diversity on grazed grassland. For these heterogeneous systems, split plot balances for areas affected either by dung, urine or pure grazing seem to be better suited than plot-scale balances.

## References

- Baker R.D. 2004. Estimating herbage intake from animal performance, 191, *In* P. D. Penning, ed. *Herbage Intake Handbook*. British Grassland Society, Reading.
- Critchley C.N.R., B.J. Chambers J.A. Fowbert A. Bhogal S.C. Rose, and R.A. Sanderson. 2002. Plant species richness, functional type and soil properties of grasslands and allied vegetation in English Environmentally Sensitive Areas. *Grass and Forage Science* 57, 82-92.
- Janssens F., A. Peeters, J.R.B. Tallwin, J.P. Bakker, R.M. Bekker, F. Fillat and M.J.M. Oomes. 1998. Relationship between soil chemical factors and grassland diversity. *Plant and Soil* 202, 69-78.

- König H.P. 2002. Stickstoffumsatz und  $N_{min}$ -Anreicherung auf Grünland während des Winters bei ganzjähriger Außenhaltung von Fleischrindern. PhD thesis, Georg-August University Göttingen.
- Petersen R.G., H.L. Lucas, and J. Woodhouse W.W. 1956. The distribution of excreta by freely grazing cattle and its effect on pasture fertility: I. Excretal distribution. *Agronomy Journal* 48, 440-444.
- Röver K.-U. 2006. Grazing behaviour and performance of beef cattle on grassland managed for biodiversity benefits. PhD thesis, Georg-August-Universität Göttingen, Göttingen.
- Sahin N. 2005. Vegetationsentwicklung und Weideleistung von Grasland bei extensiver Beweidung mit Ochsen. PhD thesis, Georg-August University Göttingen.
- Schmidt L., T. Hoppe, and F. Weissbach. 2004. Anwendung der Kotstickstoff- und der n-Alkan-Methode zur Ermittlung der Futter- und Energieaufnahme von Jungrindern auf der Weide. *Landbauforschung Völkenrode* 54, 35-44.
- Weissbach F. 1995. Über die Schätzung des Beitrags der symbiontischen  $N_2$ -Fixierung durch Weißklee zur Stickstoffbilanz von Grünlandflächen. *Landbauforschung Völkenrode* 45, 67-74.
- Wrage N., N. Sahin, K.-U. Röver, M. Hofmann, and J. Isselstein. in prep. Sward diversity in grazed pastures: What can we learn from nutrient balances?

# Grassland acreage: a key factor for estimating dairy cattle's N-excretion

Wustenberghs H.<sup>1</sup>, Fernagut B.<sup>1</sup>, Lauwers L.<sup>1</sup> and Overloop S.<sup>2</sup>

*Institute for Agricultural and Fisheries Research (ILVO), Social Sciences Unit, Burg. Van Gansberghelaan 109, box 2, B-9820 Merelbeke, Belgium*

*Flemish Environment Agency (VMM), Environment Report Flanders (MIRA), Van Benedenlaan 34, 2800 Mechelen, Belgium*

## Abstract

Animal nutrient excretion is a key factor in manure legislation and environmental monitoring. Because it can not be measured directly, total emissions are usually estimated using flat-rate coefficients. This is also the case for dairy cows, whose productivity has constantly increased over the past decade. It thus seems odd to use constant, flat-rate coefficients for estimating their N-excretion, as e.g. Flemish manure legislation has been doing (97 kg N cow<sup>-1</sup> year<sup>-1</sup>). N-excretion/cow is proportional to milk production/cow. For environmental monitoring, however, it is not easy to get milk production data at farm level. As milk production in turn is closely correlated to feed uptake, estimating nutrient excretion indirectly, by means of fodder acreage available, was explored. A significant relation was found between N-excretion per cow and the grassland and maize acreages per cow, in which the effect of grassland acreage is over 2,5 times larger than that of maize. Although average N-excretion has increased to 118 kg N/ (cow x year) on specialised dairy farms, at the regional level, the cows' increasing productivity predominates, resulting in an increased eco-efficiency.

Keywords: N-excretion coefficients, dairy cattle, fodder acreage

## Background and objectives

Social concerns about negative externalities from agricultural production exist for decades and become ever more important. Especially in regions with intensive animal husbandry, nitrates in surface and groundwater are a major element of concern. The European Nitrate Directive and local manure legislation in regions such as Flanders, the Netherlands or Brittany, that is becoming stricter with each consecutive version, both illustrate and respond to these concerns. Nutrient balances on farm or regional level have thus become important environmental monitoring and even policy instruments. A key factor in drawing up nutrient balances is animal nutrient excretion. This, however, can not be measured directly, so emissions are usually estimated through flat-rate coefficients per animal.

This is also the case for dairy cattle. However, over the past decade, dairy cattle's productivity has constantly increased. It thus seems odd to use constant, flat-rate coefficients, both over farms and over time, for estimating their N-excretion, as e.g. Flemish manure legislation has been doing over the past decade (97 kg N cow<sup>-1</sup> year<sup>-1</sup>).

From zoo technical trials it is known that there is a close relation between milk production and N-excretion. For drawing up farm gate N-balances, dairy cow's N-excretion can thus be linked to their productivity, as for instance the new Flemish Manure Decree is doing (Decree of 22/12/2006). When scaling up the individual farm level data to a regional level though, e.g. in environmental monitoring, the problem arises that it is not obvious to get sufficient data on milk production, especially when monitoring starts from Farm Structure Survey (FSS) data. Therefore an indicator for variable N-excretion was sought within the FSS-data.

## Materials and methods

For the calculation of N-excretion data were used on highly specialised dairy farms from the Flemish Farm Accountancy Data Network (FADN). Farms with suckler or fattening activities, farms that imported other animals' manure and some other outliers were eliminated. This resulted in a sample of 135 dairy farms.

For these farms the "cattle N-balance" was calculated. This differs from the farm gate balance in so far that only animal husbandry is considered - separately from crop production- and the mineral flow from the farm's own fodder production is taken into account in the same way as purchased feeds (by estimating their production and N-content).

Excretion per livestock unit was thus calculated as

$$N_{excretion} = \frac{(\sum N_{inputs} - N_{milk} - N_{animals} - metabolism)}{LU}$$

In which the N-inputs into the dairy production system are purchased milk products; purchased animals; concentrates; purchased or farm grown roughage (maize silage, fodder beets, sugar beet pulp, beer draff), grass (grazed or mowed) and straw.

N-excretion estimations were made using the environmental module of the SEPALÉ-model ([http://www.ilvo.vlaanderen.be/Social\\_sciences/Sepale\\_sector\\_model.htm](http://www.ilvo.vlaanderen.be/Social_sciences/Sepale_sector_model.htm)), which allowed including farmers' preferences. The model optimises at farm level, with opportunities to simulate exchange of intermediates, production factors and production rights.

### Estimation of farm-specific excretion coefficients

Starting point is the relation between N-excretion and productivity. N-excretion by dairy cows could be estimated through the equation:

$$N_{excretion} = 60 + 0.008 (milk\ production) \text{ [equation 1]}$$

In which both the dependent and the explanatory variable are expressed in kg N LU<sup>-1</sup> year<sup>-1</sup> (Figure 1). However, milk production is not available in the FSS data.

Therefore, for extrapolation and regional monitoring purposes, variables were sought that are available both in the FADN and in the FSS data, as explanatory variables for N-excretion. Keeping the close correlation between milk production and feed uptake in mind, the dependence was explored of N-excretion from grassland, maize, total fodder acreage (each expressed per livestock unit) and agricultural area (linked to soil type).

In a stepwise regression analysis the grass acreage available per livestock unit was found to be the key determining factor: 71% of the variation in N-excretion/LU between the farms in the sample could be explained by grassland/LU. This relation can easily be explained: space-intensive dairy farms tend to keep their cows indoors for longer periods, which means that they have better control over the cows' daily ration and they probably manage their feeding better, by which they can limit manure excretion.

A similar positive, but less strong relationship was found with maize acreage/LU. Total fodder acreage and agricultural area were no significant explanatory variables. Thus N-excretion per livestock unit could be estimated by following equation:

$$N_{excretion} = 38.23 + 265.45(grass) + 101.19(maize) \text{ [equation 2]}$$

In which N-excretion= kg N /LU  
grass = ha grassland /LU  
maize = ha silage maize /LU

Over the period 1995-2003 N-excretions per cow estimated from this equation were similar to N-excretions calculated from milk production according to the equation 1 (Figure 1) and

average N-excretion was found to have increased to 118 kg N cow<sup>-1</sup> year<sup>-1</sup> on specialised dairy farms by 2001-2003.

Figure 1 also shows that in spite of the non-decreasing excretion coefficients calculated by either equation, the farm gate N-balance clearly decreases over time.

### Sensitivity of excretion to grassland productivity

An important factor in estimating the “cattle N-balance” and the N-excretion from the fodder acreages is the productivity of the fodder crops. Silage maize productivities can be taken from the FADN data, for grassland productivity needs to be estimated, as part of it is grazed. The importance of a correct estimation can be seen from Figure 1.

The evolution of 6.2 till 7 ton DM /ha, calculated by the Belgian FPS Economy’s Directorate-general Statistics (<http://statbel.fgov.be>), clearly underestimates Flemish grassland productivity, which results in N-excretions per livestock unit that are clearly not up to date.

For estimating equation 2 an average constant productivity of 11 ton DM /ha was assumed over the 1995-2003 period, according to Coomans *et al.* (2000). It was argued that a more judicious fertilisation countered the effect of stricter manuring regulations and decreasing fertilizer use. Currently though, as the vulnerable zones water, in which manuring is limited to 170 kg N/ha, are expanded and the acreage of grassland under management agreement is increasing an average productivity of 10.5 ton DM /ha seems more realistic. When estimating N-excretion through fodder acreage (equation 2) this would entail a decrease of about 4 kg per cow and per year.

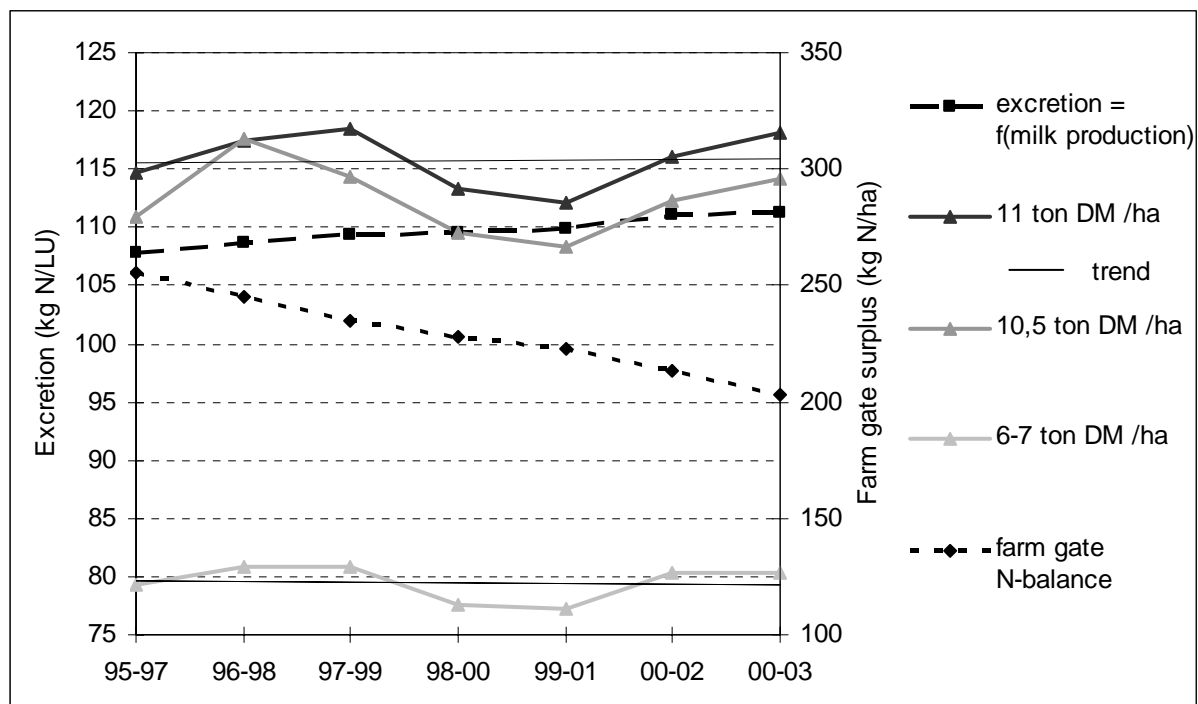

Figure 1: Farm gate N-balance on the sample farms (1996-2002) and evolution of N-excretion per livestock unit calculated from milk production or from fodder acreage, with different assumptions for grassland production (ton DM/ha).

Farm gate balance is exclusive NH<sub>3</sub>-emission.

## Implementation of variable N-excretion factors for dairy cattle

When extrapolating this relation to the entire population and over the past decade, it becomes clear that N-excretion/cow in Flanders has increased by almost 8% between 1995 and 2004 (Figure 2). However, at the regional level this increasing trend is shown to be less important than the cows' increasing productivity: over the same period milk production/cow increased by 21%. Thus, an almost constant level of milk production was achieved with 31% less cows, which adds up to a total N-excretion by dairy husbandry that is down by 11.4%. This means that on the regional level there has been a decoupling between the 'driving factor', milk production, and the environmental 'pressure', N-excretion, and that eco-efficiency of dairy husbandry has clearly increased.

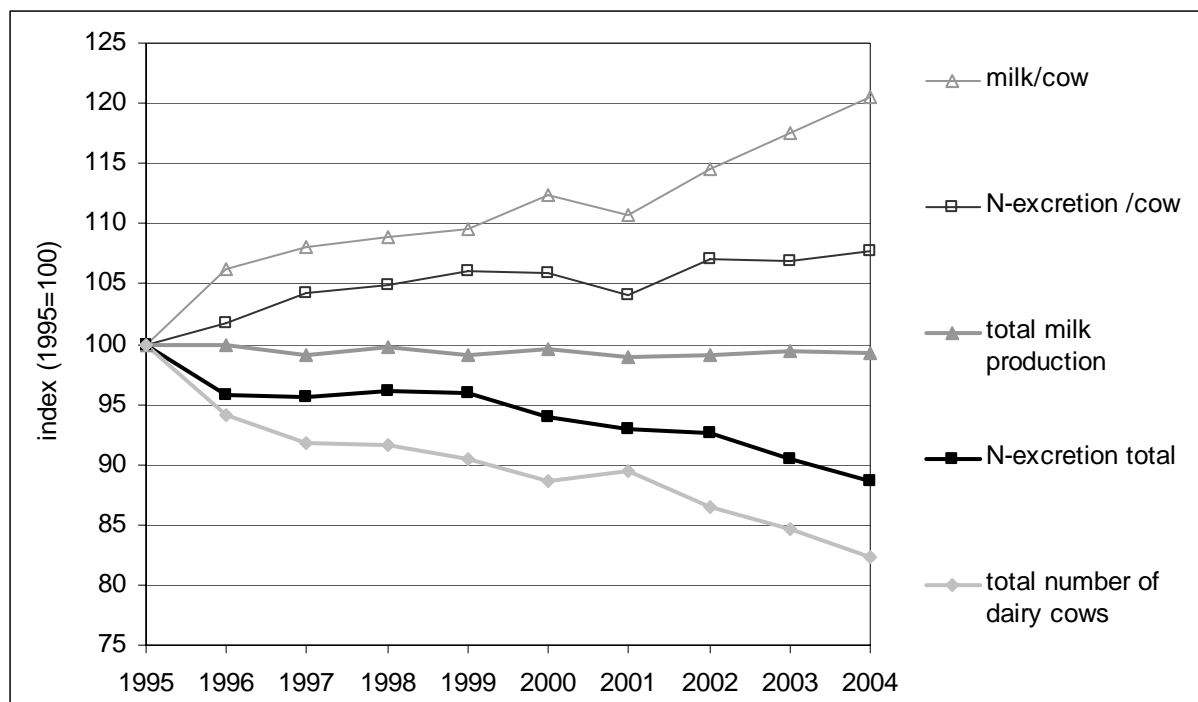

Figure 2: Eco-efficiency of milk production (Flanders, 1995-2004)

Milk production was calculated as deliveries to milk factories, which cover about 99 % of total production.

## Conclusions

It was shown that variable N-excretion coefficients for dairy cattle that are consistent with the cows' productivity can also be estimated through fodder acreages. Both at farm and at regional level grassland acreage is the key factor in this estimation.

At the regional level, the cows' increasing productivity predominates their increasing N-excretion, resulting in an increased eco-efficiency of the sector.

## References

Coomans D., Rombouts G., De Brabander D., De Vliegheer A., Melengier M., Sonck B., Van Bockstaele E., Vervaeke V., Verbruggen I., Van Nieuwerburgh G., Dewilde J., Audenaert D., Vandepoel G., De Smet G., Standaert O., Bries J., Beke M. (2000). *Kostprijsraming ruwvoerders 2000*. Ministerie van Middenstand en Landbouw, Brussel.

Decree 22.12.2006, Decreet houdende de bescherming van water tegen verontreiniging door agrarische bronnen. *Belgisch Staatsblad - Moniteur Belge* 29.12.2006.

# **N-balances and model calculated N-losses from typical intensive dairy farms in Northern Europe**

Kristensen I.S. and Kristensen T.

*Uni. of Aarhus, Fac. of Agri. Sc., Res. Centre Foulum, Dep. of Agroecology, PO Box 50, DK-8830 Tjele, Denmark*

## **Abstract**

Bases on the approved balancing principles of the EGF working group “Dairy Systems and environment”, coherent herd and field/soil N-balances of common intensive dairy systems in northern Europe have been calculated. The results are initially based on the data presented at the Quimper meeting held in 2003 (Bos *et al.*, 2005). The discussion at the meeting showed inconsistencies underneath the farm gate balance. For example, inputs for the herd were not always equal to output from the field, and visa versa. An approved model of Schröder *et al.* (2005) has been used to present representative data from each country in a consistent way, making it possible to make meaningful comparisons. Inconsistencies are identified and should be studied across countries in order to evaluate the possibilities of improvements based on common approved methods.

Keywords: N-balances of farm gate, herd and field/soil, standard N-losses

## **Introduction**

At the Quimper meeting it became clear that different countries used different methods for quantifying the average N-losses from their dairy sectors. In order to make strict comparisons between environmental losses in north European intensive dairy regions the model of Schröder *et al.* (2005), has been used to establish N-balances on the typical dairy farms data presented at the Quimper meeting in 2003 (Bos *et al.*, 2005). At that meeting farm gate balances were published for each country. Farm gate N-surplus represents the potential N-losses (Halberg *et al.*, 1995), but in order to calculate the different losses it is necessary to establish the internal N-flows on the dairy farm. The internal flows are important in order to understand the management and to suggest possible ways of improvement. This paper presents a method for calculating the environmental losses, which makes it possible to make strict comparisons between countries.

## **Materials and methods**

In order to calculate the internal N-flows on dairy farms the output from the field is defined being equal to N-uptake in the dairy herd plus N in straw for bedding, and the manure N-production from the herd minus aerial N-losses is equal to manure N-input to the fields. This simplification means that storage losses of crops are included in the field balance, and if these net yields are to be compared to yields harvested (gross yield) the field and storage losses have to be included.

Different countries have given different data for herd and field balances. If net yield of homegrown feed were missing, the yields were calculated from manure applied to the field, assuming 10% aerial N-loss of animal manure. If manure was missing, the manure for the fields was calculated from manure excreted from the herd. If data from both yields and manure production were missing, these data are calculated from produced animal products,

assuming an N-efficiency in the herd of 20%. The result of the assumptions is that homegrown feed and manure are equal in the herd and field balance. In Table 1 the data used for calculation of missing data are marked with<sup>1</sup>. The herd N-balance inputs is shown without bedding in order to evaluate the feed utilization, an herd roughage inputs is sum of imported (farm gate) and homegrown (field) feed.

In order to break the farm gate N-surplus into losses, the ammonia losses in stall and storage are assumed to be 10% of excreted N, and spreading losses 8% of applied N ([www.Alfam.dk](http://www.Alfam.dk)). Denitrification is calculated with SimDen, ver. 2.0 UK (Vinther and Hansen, 2004). SimDen calculates denitrification from N-inputs of inorganic N, manure N and fixation, soil types and “prehistory”. Soil-N changes are calculated with C-tool (Berntsen and Petersen, 2005). C-tool calculates soil-N changes from C-inputs from manure and plant residues in the soil. The soil-N changes are calculated with typical Danish initial soil-N and – C contents in the root zone.

## Results and discussion

In Table 1 the main characteristics are shown. National Figures of LSU (Livestock Units) are used in order to show the different proportions of heifer, sucker cow and bull production. The Netherlands in 1995 (NL) had a high milk production per cow and high importation of external feed, whereas Ireland (Ir) had a low production level per cow. In Ir and UK the production is based on nearly 100% grassland forage, whereas other countries have considerable maize areas. In countries with low milk production per ha crops for sale are produced on 20-34% of the farm area, primarily in DK where grain production is compensated by a high importation of concentrates per cow.

The farm gate N-balance is from Bos *et al.* (2005), and the herd and field N-balances are partly calculated (see Materials and methods for assumptions). The countries are ranked by increasing farm gate N-balances.

The N-efficiency in herds shows no clear relationship to external feed imports or to grazing intensity. Surprisingly Ireland (Ir) has a high efficiency of grazing utilization, indicating that high grass-yield and/or low protein content have been assumed. Again detailed data could be valuable in order to understand and explain the different efficiencies. If for example a standard LSU could be defined the herd balance could be evaluated per LSU.

The field N-surplus expresses the same trend as the farm gate N-surplus, because of relatively low ammonia N-losses in stalls and manure storage (10% of excretion). N-efficiency in the field is only 34-42% in UK and NL, corresponding with very high inputs. Other countries have 48-61% N-efficiency in the field. Without data for yield and N-content in roughage fodder it is not possible to do further judgements of the efficiencies. For example the protein content can switch between high and low efficiency between herds and fields: High protein content in grass results in high N-efficiency in the field and a corresponding low N-efficiency in the herd. The published representative farm gate N-balance (Bos *et al.*, 2005) is shown with the calculated losses. On specialized dairy farms with major outputs as milk and meat the surplus is primarily affected by fertilizer and feed inputs. The farm gate N-efficiency (% output/input) is also decreasing with increasing N-surplus. If only animal products are included in the output and the sales of cash crops is deducted from feed imports, the N-efficiency of dairy production (Halberg *et al.*, 1995) can be calculated showing low efficiencies in UK and in NL. The published ammonia losses (Bos *et al.*, 2005) vary considerable between countries as different methods are used for quantification. A standardized method could be valuable, but is only possible if climate, stall, storage and spreading systems are considered, like the Alfam-model for calculating spreading ammonia losses, ([www.Alfam.dk](http://www.Alfam.dk)) The national differences become even worse when denitrification and soil-N changes are considered. In Ir



denitrification and soil-N changes are given in the same Figure adding up to 173 kg N ha<sup>-1</sup>. In NL the denitrification is calculated as the unaccounted rest of 213 kg N ha<sup>-1</sup> assuming no soil-N changes. In UK Jarvis (2003) assume both denitrification (63 kg N ha<sup>-1</sup>) and soil-N changes (133 kg N ha<sup>-1</sup>) as high and still have 56 kg N ha<sup>-1</sup> as unaccounted.

**Table 1.** Main characteristics, N-balances and estimated N-losses of typical intensive dairy farms in Northern Europe around year 2000.

Country <sup>3)</sup>	Fr	DK	Ge	Be	Ir	UK	NL
Farm area, [ha/farm]	26	84	82	32	52	87	27
Dairy cows, [cows/farm]	28	72	71	54	107	121	48
Herd, [LSU/farm]	38	113	105	96	136	169	74
Kg delivered ECM/cow	6420	7755	8049	5827	6000	5883	7290
Kg delivered ECM per ha	6000	7095	6922	9643	12300	8128	12778
Concentrate for cows, kg/cow	580	2557	1586	1132	722	1360	2234
Crops, pct. of total farm area							
Grass/clover, total	54%	36%	56%	63%	100%	91%	79%
-with permanent grass	50%	12%	34%	40%	100%	80%	65%
-used for grazing	30%	36%	39%	32%	57%	38%	46%
Maize, whole crop	26%	31%	23%	16%	0%	0%	21%
<b>Herd N-balance, [kg N/ha]</b>							
Concentrates, incl. grain	43	97	86	76	35	68	125
Forage crops, incl. import	188	121 <sup>1)</sup>	137 <sup>1)</sup>	283	308 <sup>1)</sup>	177	287
<i>Total N-inputs</i>	<i>231</i>	<i>218</i>	<i>224</i>	<i>359</i>	<i>343</i>	<i>245</i>	<i>412</i>
Milk	33	37	34	49	67	43	64
Meat	8	9	7	16	8	6	14
<i>Total N-outputs</i>	<i>41</i>	<i>46</i>	<i>41</i>	<i>65</i>	<i>75</i>	<i>49</i>	<i>78</i>
<b>Herd N-balance=N ab animal</b>	<b>190</b>	<b>172</b>	<b>182</b>	<b>294</b>	<b>268</b>	<b>196</b>	<b>335</b>
<i>Neff<sub>Herd</sub>, [% of inputs]</i>	<i>17,8%</i>	<i>21,1%</i>	<i>18,5%</i>	<i>18,1%</i>	<i>22,0%</i>	<i>20,0%</i> <sup>2)</sup>	<i>18,9%</i>
<b>Field/soil N-balance, [kg N/ha]</b>							
Manure-N from own herd	171 <sup>1)</sup>	155	164	264	241	176	302
Manure imported	42	4	0	31	0	0	50
Artificial fertilizer	78	63	131	128	330	324	242
N-fixation	25	27	0	6	0	10	0
Precipitation	15	16	30	48	10	15	48
<i>Total N-inputs</i>	<i>331</i>	<i>265</i>	<i>325</i>	<i>477</i>	<i>581</i>	<i>525</i>	<i>642</i>
Forage crops	188	121	137	266	308	177	268
Cash crops	15	9	19	2	0	0	0
<i>Total N-outputs</i>	<i>203</i>	<i>130</i>	<i>156</i>	<i>268</i>	<i>308</i>	<i>177</i>	<i>268</i>
<b>Field/soil N-balance</b>	<b>128</b>	<b>134</b>	<b>168</b>	<b>209</b>	<b>273</b>	<b>344</b>	<b>374</b>
<i>Neff<sub>Field</sub>, [% of inputs]</i>	<i>61%</i>	<i>49%</i>	<i>48%</i>	<i>56%</i>	<i>53%</i>	<i>34%</i>	<i>42%</i>
<b>Farm gate N-balance, [kg N/ha]</b>							
Artificial fertilizer	78	63	131	128	330	324	242
Manure imported	42	4	0	31	0	0	50
Concentrates	43	97	86	76	35	68	125
Precipitation & fixation	40	43	30	54	10	25	48
Roughage & straw	5	5	0	17	0	0	20
<i>Total N-inputs</i>	<i>208</i>	<i>212</i>	<i>247</i>	<i>306</i>	<i>375</i>	<i>417</i>	<i>485</i>
Animal products	41	46	41	65	75	49	78
Cash crops	15	9	19	2	0	0	0
<i>Total N-outputs</i>	<i>56</i>	<i>55</i>	<i>60</i>	<i>67</i>	<i>75</i>	<i>49</i>	<i>78</i>
<b>Farm gate N-balance, [kg N/ha]</b>	<b>152</b>	<b>157</b>	<b>186</b>	<b>238</b>	<b>300</b>	<b>367</b>	<b>407</b>
<i>Neff<sub>Farm</sub>, [% of inputs]</i>	<i>27%</i>	<i>26%</i>	<i>24%</i>	<i>22%</i>	<i>20%</i>	<i>12%</i>	<i>16%</i>
<i>Neff<sub>Dairy</sub>, [% of net inputs], see text</i>	<i>21%</i>	<i>23%</i>	<i>18%</i>	<i>21%</i>	<i>20%</i>	<i>12%</i>	<i>16%</i>
<b>Standard N-losses, [kg N/ha]</b>							
Total amm.-N, DK	46	39	36	58	54	40	68
Denitrification, SimDen	42	16	29	71	73	88	37
Soil-N changes, C-tool.	-3	14	27	11	30	25	60
N-leaching, national values	42	74	124	125	50	48	124
Unaccounted	26	15	-29	-27	93	166	118

1) Data from Bos et al. (2005) used for calculating yield of forage or manure production. 2) Assumed.

3) Fr=North Vest France- Quimper, DK=Denmark, Ge=North Germany, Ir=Ireland, UK=South Vest England, NL=Netherlands, sandy soil.

In order to compare the losses equally two Danish models are used for quantifying denitrification (SimDen) and soil-N changes (C-tool). If the Danish models are used the unaccounted for remainder is still big in countries with a high N-surplus: Ir, UK and NI, showing how difficult it is to get comparable Figures between countries. However the models indicate considerable denitrification taking place in wet climate on soils with high clay content like in UK and Ir. In NI on sandy soil the SimDen calculated that denitrification is probably underestimated because of high ground water.

The C-tool model was used for calculating soil-N changes in all the north European countries using the Danish Figures for initial soil C- and N-content. In warmer climate (Fr) the turnover is expected up to 30% faster and in Ir and UK the initial soil-C and -N are higher than the used Danish initial values. For this reason the calculated Figures of soil-N changes shall be used by causes. Although C-tool still suggests N accumulation in most countries, this contradicts the published country Figures, where only soil-N accumulation is assumed only in UK, DK and Ir. In contrast, soil-N is assumed in steady state in other countries.

If a common method for a simple separation of the farm gate N-balance into herd and field/soil N-balance and losses/soil-N changes could be established across Europe, a good basis for evaluating present levels of pollution could be established. Also, the effects of improvements in different countries could be evaluated on a sound basis. The above method only includes a minimum of assumptions and could be used as the first suggestion for discussion. In order to achieve a common agreed basis it is important to include experts in animal feeding, roughage production and quantification of N-losses/soil-N changes. The first step would be to quantify roughage production and net feed uptake of homegrown feed in order to establish a sound basis for calculating N-efficiency in herds, which seems incomparable in Table 1. Further work in the EGF working group 'Dairy Farming Systems and Environment' will progress this topic.

## Conclusions

N-balances of farm gate, herd and field/soil has been modelled consistently in order to compare model calculated N-losses from typical intensive dairy farms in Northern Europe. A suggestion has been given for setting output from herd equal to input to field/soil and visa versa. In order to calculate N-losses consistently soil-N changes has to be included and multinational cooperation of experts is necessary in order to develop agreed models and assumptions.

## References

- Berntsen J. and Petersen B.M. (2005) C-TOOL, Danish version, see <http://web.agrsci.dk/jbe/bin/ctool.html>.
- Bos J., Pflimlin A., Aarts F. and Vertés F. (2005) Nutrient management on farm scale. How to attain policy objectives in regions with intensive dairy farming. *Report of the first workshop of the EGF Working Group "Dairy Farming System and Environmental"*. Quimper, France, 23-25 June 2003. Wageningen, The Netherlands, Plant Research International. 83, 1-270.
- Halberg N., Kristensen E.S. and Kristensen I.S. (1995) Nitrogen turnover on organic and conventional mixed farms. *Journal of Agricultural and Environmental Ethics* 8[1], 30-51.
- Jarvis S.C. (2003) N balances on farms. Hang out paper from presentation of farm cases at the Quimper meeting 23-26 June 2003: Nutrient management on farm scale. How to attain policy objectives in regions with intensive dairy farming. Page 1-4.
- Schröder J.J. Vertés F., Chadwick D.R. and Kristensen I.S. (2005) How to compare the nutrient use efficiency of dairy farms? Offered at "Second meeting EGF-working group "Dairy farming systems and environment". Sunday 23 Oct. 2005. Maastricht. Pp. 13.
- <http://www.agrsci.dk/var/agrsci/storage/original/application/2631bb7eb1dad7bc866028fe6c9e51e5.pdf>.
- Vinther F.P. and Hansen S. (2004) SimDen - en simpel model til kvantificering af N<sub>2</sub>O-emission og denitrifikation. *Danmarks JordbrugsForskning. Rapport Markbrug*. 104, 1-47. See [www.agrsci.dk/SimDen](http://www.agrsci.dk/SimDen) for English version.

# Production and nitrogen losses from dairy farms using an extended grazing management system

Jewkes E.C.<sup>1</sup>, Webb, J.<sup>2</sup>, Butler, M.R.<sup>1</sup> and Scholefield, D.<sup>1</sup>

<sup>1</sup>IGER, North Wyke, Okehampton, Devon, EX20 2SB, UK

<sup>2</sup>(Formerly) ADAS Research and Development, Woodthorne, Wergs Road, Wolverhampton, UK

## Abstract

A 3-year study was established in order to investigate the flows of nitrogen through and from dairy farms using an extended grazing management system. Measurements of herbage dry matter yield, herbage N yield, soil mineral N, denitrification, ammonia volatilisation and leaching /runoff were carried out on each farm. The computer models NGAUGE and MAST were used to compare the measured results with a theoretical conventional management. Herbage yields were mostly in the range of 8.7 – 10 t ha<sup>-1</sup> yr<sup>-1</sup>, with N yields corresponding to DM and fertiliser use. Denitrification losses were generally modest, but some peak values were observed after rainfall and occasionally following late season fertiliser applications. Volatilisation rates were similar to those expected in conventional managements. Leaching losses were high, with rates commonly of 100-150 kg N ha from the 3 sites with permeable soils. Comparing the measured throughputs with a modelled conventional scenario showed that DM and denitrification did not differ between the systems. Total ammonia losses were smaller from the extended grazing system in 3 out of 4 cases but leaching was increased.

Keywords: extended grazing, nitrogen, herbage yield, ammonia volatilisation, leaching

## Introduction

Grazed grass has long been recognised as the cheapest source of food for dairy cows. As milk prices have declined in the UK, there has been a corresponding increase in interest in the “extended grazing” management, as commonly practiced in the Republic of Ireland and New Zealand. Under this system, grazed grass provides the primary food source for the dairy herd for as much of the year as possible, with grazing often continuing for 9 or 10 months, or all year round in some cases. This compares to the “conventional” 6 to 7 months grazing season on most dairy farms. In the extended grazing system, conserved or purchased forages are used to supplement the diet when the available grass is not sufficient; whilst concentrate feeds are used, the amounts are usually minimised and are commonly 500 kg per cow or less.

Whilst there are a number of studies examining the herbage and animal or yield responses to early and late grazing in the year (*e.g.* Laidlaw and Maine 2000, Dillon *et al.*, 1998), there have been few, particularly in the northern hemisphere, which have sought to characterise the nutrient throughputs and environmental impacts of the system. A desk ADAS / IGER study (Webb *et al.*, 2004) suggested that losses of ammonia to the atmosphere were likely to be reduced as a result of the shorter housing period, whilst nitrate leaching might increase, relative to a conventional management. However, this study was essentially model-based, and there was awareness that few field data sourced specifically from extended grazing managements existed. Subsequently, we established a 3-year field trial in order to provide what is currently one of the most comprehensive datasets for nitrogen flows in an extended grazing management under UK conditions.

## Materials and methods

Four farms were identified in early 2002, encompassing a broad geographical spread and different soil types, as well variations in management (*ie* fertiliser and feeding regimes) within the remit of the extended grazing principle. One paddock per farm was used for the study.

A suite of field measurements was undertaken at each farm, including: herbage dry matter (DM) yield, herbage N yield, Soil mineral N (SMN), denitrification, ammonia volatilisation and nitrate leaching or runoff (as appropriate to soil type). Herbage yield was measured by cutting 20 replicate strips of 100 x 10 cm, using clippers adapted to cut at a known height, before and after each grazing rotation on the trial paddock, with DM yield taken as the *pre-graze yield minus the previous after-graze yield*. Herbage N yield was assessed from the pre-graze samples. SMN to 30 cm depth was determined every 4-6 weeks.

Denitrification was assessed using a method of soil core incubation with acetylene blocking (after Ryden and Skinner, 1987). Measurements were made prior to and on 2 days following fertiliser application. Ammonia volatilisation measurements were carried out using the micrometeorological mass balance method described by Misselbrook and Hansen 2001. Measurements were carried out in response to grazing, slurry spreading and urea fertiliser applications. There were few slurry and urea applications so data for these were limited.

Leaching and runoff losses of NO<sub>3</sub>-N were measured using ceramic cup samplers at the sites with freer draining soils (farms 1-3), whilst the site on a clay soil (farm 4) was instrumented with 3 lysimeters, each draining to a flow-proportional water sampler ("tipping bucket"). The ceramic cups and lysimeters were sampled according to rainfall throughout the winter drainage periods.

The decision support system NGAUGE (Brown *et al.*, 2005) and the ammonia mass-balance model MAST (Ross *et al.*, 2002) were used to estimate the losses and production of theoretical equivalent conventional farms, in order to compare the two managements.

## Results and discussion

Herbage DM yields over the 3 grazing seasons ranged from 5.8 to 10.5 t DM ha<sup>-1</sup>, although most were in the range 8.7 to 10 t DM ha<sup>-1</sup> (Table 1). Yields were lowest at Farm 1, which was a site of low rainfall with a very sandy soil, whilst the remaining 3 sites were more similar in output. Although Farm 3 had the highest overall fertiliser N use, here was no difference in DM yield between the 3 more productive sites; this is likely to reflect a combination of factors such as climate, rainfall and site growth class, as well as pasture and fertiliser management. Herbage N yields tended to follow DM yield and fertiliser use, and are thus much as expected.

Table 1. Herbage DM yield and means

	Farm 1	Farm 2	Farm 3	Farm 4	
Year 1	8419	8940	10082	9991	
Year 2	5856	9119	10563	8708	
Year 3	7192	9245	8786	10092	
Mean	7156	9101	8786	10092	Grand mean 8916

Soil mineral N values were generally modest, with most measurements being <50 kg ha<sup>-1</sup>, and many being well below this. Accumulations of SMN during the summer months, as have been measured in studies on conventional farms (unpublished data), were not routinely observed, although in the drought year of 2003 Farm 2 showed a substantial rise towards late summer, as growth and thus N uptake diminished.

The denitrification values measured following fertiliser applications were mostly modest (Figure 1a), and within the range of values recorded in routine measurements made at North Wyke (unpublished data). Some peak values were observed; these mostly occurred during the normal fertiliser use period and appeared to be triggered by rainfall close to application. There were 2 occasions at Farm 3 where peaks were observed following late season applications (Figure 1b), highlighting the risks involved with fertiliser use at these times.

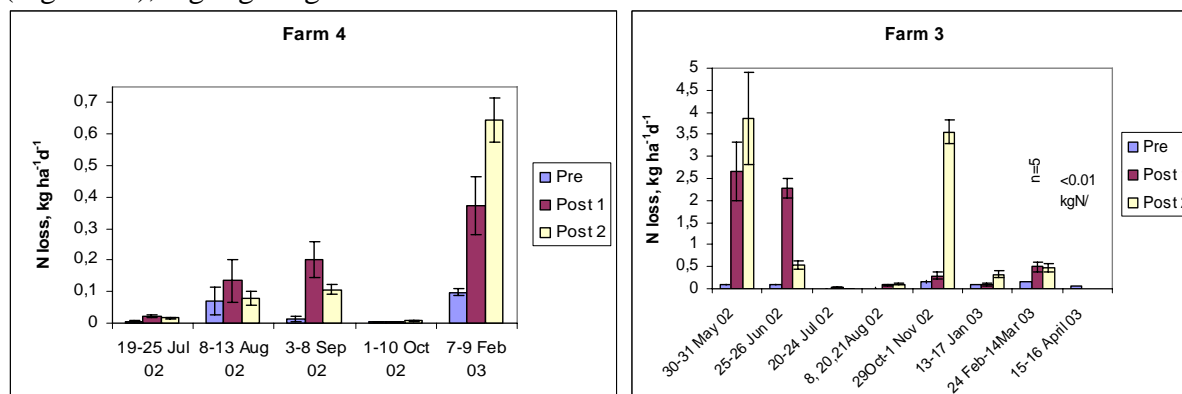

Figure 1 a) and b). Moderate and peak denitrification measurements on farm 3 and 4.

Ammonia emissions during grazing fell into the range predicted by the UK Ammonia Emissions Inventory – ie similar values to those expected in a conventional grazing system. Using the mean fertiliser application rate for all 3 farms to calculate expected emissions resulted in a Figure of 22 g N LU<sup>-1</sup> d<sup>-1</sup>, whereas the mean measured Figure was 17 g N LU<sup>-1</sup> d<sup>-1</sup>. For most farms the predicted rate was close to the measured, but the rate was over-predicted at Farm 4 where the clay soil is likely to be more retentive of NH<sub>3</sub>.

Leaching losses (Table 2) were high at the 3 sites with more permeable soils. Losses over the 3 measured drainage periods ranged from 100 to 300 kg N ha<sup>-1</sup>, although most were in the region of 100-160 kg ha<sup>-1</sup>. The largest loss was recorded at Farm 2 following the drought summer of 2003, when an accumulation of SMN was also observed. Generally, however, the high leaching losses did not appear to correspond to SMN values. The results here find some agreement with Laidlaw *et al.*, (2000), who found no link between early or late season grazing and SMN levels; our study, however, demonstrates that this does not necessarily preclude large leaching losses. These are assumed to be due to the heterogeneity of urinary returns to the soil, causing substantial losses but being difficult to detect within a normal sampling regime. In contrast to Farms 1-3, Farm 4 showed much more modest N losses from the lysimeters at 16-25 kg N ha<sup>-1</sup>. Peak concentrations of N were high at all 4 sites; at Farm 4 these occurred towards the end of the drainage period at low flows and thus made little difference to the total loss, whereas at Farms 1-3 they tended to occur early in the drainage period and made a more substantial contribution.

Table 2. Leaching/runoff losses and peak concentrations (Farm 4, year 1, no data)

Farm	Year	NO <sub>3</sub> -N loss, kg ha <sup>-1</sup>	Peak NO <sub>3</sub> -N conc, mg l <sup>-1</sup>
1	1	130	44.7
	2	109	68.3
	3	281	181.8
2	1	159	47.3
	2	30	103.7
	3	225	96.2
3	1	101	18.3
	2	161	54.6
	3	193	61.1
4	2	25	80.9
	3	16	48.2

Using models to compare field production and losses to the environment from analogous but theoretical conventional farms showed no difference in DM yield or denitrification. Ammonia losses from grazing alone were lower from the conventional system because of the shorter grazing period whilst those from *grazing + housing* (calculated to equate to the 177d housed period of the conventional system) were lower from the extended grazing system in 3 out of 4 cases (Table 3). This is as expected, as losses are known to be greater from housing, relative to grazing, and the housed period is shorter in the extended grazing system. The magnitude of difference in ammonia loss was consistent with the estimations of Webb *et al.*, (2004), who suggested a 7-9% reduction per month of extra grazing. Our results suggested a 3-month extension of grazing would occur in most cases, with a mean reduction of 25% in emission. A comparison of leaching losses showed that total N loss and average concentration would be greater from the extended grazing system, which befits the high losses observed in the study. Peak N concentration, however, did not differ between the two managements.

Table 3. Calculated ammonia losses (kg farm<sup>-1</sup>) from conventional management housed period and equivalent *grazed + housed* period in extended grazing system

Farm	Mean (housed + grazing) for 177d	Conventional housed (177d)
1	452	1317
2	1113	1535
3	1493	1473
4	1299	1372

## Conclusions

Extended grazing thus appears to offer good levels of production in a grazed sward, but with different patterns of loss to a more conventional management with a longer housed period. Ammonia losses appear to be reduced under extended grazing whilst leaching losses are enhanced. Both processes are important with regard to EU environmental legislation, meaning that it is difficult to suggest a preference for one management over the other, and that studies to investigate potential mitigation strategies to reduce leaching would be worthwhile.

## References

- Brown, L., Scholefield, D., Jewkes, E.C., Lockyer, D.R. and del Prado, A. (2005) NGAUGE: a decision support system to optimise N fertilisation of British grassland for economic and environmental goals. *Agriculture, Ecosystems and Environment* 109, 20-39
- Dillon, P., Crosse, s and Roche, JR. (1998) The effect of grazing intensity in late summer/autumn on sward characteristics and milk production of spring-calving dairy cows. *Irish Journal of Agricultural and Food Research* 37, 1-15
- Laidlaw, A.S. and C.S. Mayne (2000) Setting management limits for the production and utilization of herbage for out-of-season grazing. *Grass and Forage Science* 55, 14-25
- Laidlaw, A.S., C.J. Watson and C.S. Mayne (2000) Implications of nitrogen fertilizer applications and extended grazing for the N economy of grassland. *Grass and Forage Science* 55, 37-46
- Misselbrook, T. H., Chadwick, D. R., Chambers, B. J., Smith, K. A., Webb, J., Demmers, T. and Sneath, R. W. (2006) Inventory of Ammonia Emission from UK Agriculture, 2004. Inventory submission report to Defra (Project AM0127).
- Misselbrook, T. H. , Hansen, M. N. (2001) Field evaluation of the equilibrium concentration technique (JTI method) for measuring ammonia emission from land spread manure or fertiliser. *Atmospheric Environment* 35 (22), 3761-3768
- Ross, C.A., D. Scholefield and S.C. Jarvis (2002) A model of ammonia volatilisation from a dairy farm: an examination of abatement strategies. *Nutrient Cycling in Agroecosystems* 64 (3),273-281
- Ryden, J.C and Skinner, J.H. (1987) Soil core incubation system for the field measurement of denitrification using acetylene inhibition. *Soil Biology and Biochemistry* 19 (6),753-757
- Webb, J, Anthony, S.G, Brown, L, Lyons-Visser, H, Ross, C, Cottrill, B, Johnson, P and Scholefield, D. (2004) The impact of increasing the length of the cattle grazing system on emissions of ammonia and nitrous oxide and on nitrate leaching in England and Wales. *Agriculture, Ecosystems and Environment* 105 (1-2), 307-321

# Fertiliser recovery of different N-sources on grassland as studied by difference and isotope method

Nannen D.U.<sup>1</sup>, Dittert K.<sup>2</sup>, Loges R.<sup>1</sup> and Taube F.<sup>1</sup>

<sup>1</sup>*Institute of Crop Science and Plant Breeding, -Grass and Forage Science/Organic Agriculture-, Christian Albrecht University Kiel, Germany*

<sup>2</sup>*Institute of Plant Nutrition and Soil Science, Christian Albrecht University Kiel, Germany*

## Abstract

A field experiment was conducted on permanent grassland in Schleswig-Holstein/Germany, for a comparative study of fertiliser nitrogen recovery based on apparent nitrogen recovery (ANR) and the <sup>15</sup>N isotope method (FNR). In a first part, <sup>15</sup>N-labelled mineral nitrogen (N<sub>MF</sub>) was applied to a ryegrass-clover sward in a cut-and-carry-system at rates of 100, 200 and 300 kg mineral N ha<sup>-1</sup> combined with unlabelled slurry (N<sub>SL</sub>; 70 kg N ha<sup>-1</sup>). In a second part, <sup>15</sup>N-labelled slurry was applied (70 kg N ha<sup>-1</sup>) in a mixed system (2 cuts, subsequent grazing) in combination with unlabelled mineral N (0, 100, 200, 300 kg N ha<sup>-1</sup>). Accumulated over all defoliations (DEF), annual FNRs for mineral fertiliser nitrogen ranged between 52% and 54%. Annual ANRs were 69% to 76%. In the slurry experiment, total FNRs of total slurry N were 14-18%, depending on the rate of additional mineral N-fertiliser; total ANRs ranged between -20% and +29%. In the mineral fertiliser experiment the differences between both methods were significantly influenced by DEF, indicating that there was no linear relationship of FNR and ANR over time. In the slurry experiment the differences were not significant, however a Bartlett-Test proved FNR to be more precise than ANR.

Keywords: <sup>15</sup>N, difference method, grassland, mineral fertiliser, slurry

## Introduction

Northwest European intensive dairy farms are characterized by high inputs of organic and mineral nitrogen fertilisers inducing high surpluses of farm gate balances (Van der Meer, 2002; Westhoek *et al.*, 2004). Whilst in former days these circumstances did not attract much interest, today's farmers are liable to economical, legislative and ecological frameworks. Therefore optimal fertiliser efficiency has to be aspired.

Recovery rates of mineral and organic N-fertilisers can be gained by tracer studies (fertiliser nitrogen recovery, FNR) or by N-yield differences (apparent nitrogen recovery, ANR). Both methods are subject to errors (Rao, 1992) which can be more pronounced on humus-rich soils. Aim of this study was an evaluation of methods for a quantification of N-fluxes in the plant-soil-system under permanent grassland in order to estimate nitrogen use efficiency of mineral and organic N-fertilisers.

## Materials and methods

The field experiment was set up on the research farm Karkendamm in Schleswig-Holstein/North Germany (14m A.S.L.; 8.4°C annual mean temperature; 823 mm annual rainfall). The soil was a peaty podzol with coarse sand texture, a clay content of 5-7% and pH of 4.5-5.0.

The recovery study was carried out in 2000-2001 on permanent grassland which was ploughed and resown in 1995 with a ryegrass dominated clover-ryegrass seeding mixture

(*L.perenne* L., *T.repens* L.). Different defoliation systems were established; further details are given in Trott *et al.* (2004). <sup>15</sup>N-labelled cow slurry (N<sub>SL</sub>; 2000: 67 kg N ha<sup>-1</sup>, 0.7224 at % <sup>15</sup>N; 2001: 81 kg N ha<sup>-1</sup>, 0.7181 at % <sup>15</sup>N) and <sup>15</sup>N-labelled mineral fertiliser (N<sub>MF</sub>; 0/100/200/300 kg N ha<sup>-1</sup>; 1.4426 at % <sup>15</sup>N) were applied in a mixed system (2 cuts and subsequent grazing) and in a cut-and-carry-system (4 cuts), respectively; mineral fertiliser was applied in up to 4 dressings, slurry was applied in spring (Table 1). In addition to the labelled slurry, unlabelled mineral fertiliser was applied and *vice versa* unlabelled slurry to labelled mineral fertiliser. Unlabelled mineral fertiliser and slurry were applied at same rates and dressings as labelled sources (Table 1).

At harvest dates (DEF) the aboveground biomass was cut in the centre 0.25 m<sup>2</sup> of each plot

Table 1: N-dressings during the vegetation period (kg N ha<sup>-1</sup>)

mineral N [kg ha <sup>-1</sup> ]	defoliation			
	1	2	3	4
0	.	.	.	.
100	70	30	.	.
200	100	50	50	.
300	130	70	50	50
slurry	67/81	.	.	.

leaving a stubble height of 5 cm. Samples were dried (70°C) and homogenized in a ball mill (MM200 Retsch, Haan Germany). The <sup>15</sup>N-content was measured with a mass spectrometer (delta C, ThermoFinnigan, Bremen, Germany) coupled with an elemental analyser. Total N content was determined by NIRS (near-infrared-spectroscopy); the calibration was based on wet chemical analysis according to Kjeldahl method (Naumann and Bassler, 1976). Fertiliser recovery rates obtained with the isotope method (FNR) were calculated

according to Hauck and Bremner (1976). Apparent nitrogen recovery rates (ANR) were similarly calculated as in Wagner (1954). However in our study it was not possible to differentiate between N recovery of the latest application and N recovery of previous fertiliser dressings in regrowths. Therefore the apparent nitrogen recovery was calculated on a cumulative basis (ANRc). Furthermore the biological nitrogen fixation (BNF) was considered. It was calculated according to Trott *et al.* (2004). So the cumulative BNF-corrected ANR in defoliation n was calculated as

$$\text{ANRcc}(n)[\%] = [(\sum N_{Y_{\text{fert}}} - \sum \text{BNF}_{\text{fert}}) - (\sum N_{Y_{\text{unfert}}} - \sum \text{BNF}_{\text{unfert}})] / \sum F_{\text{appl}} * 100$$

with  $N_{Y_{\text{fert}}}$  = nitrogen yield of fertilized plot [kg N ha<sup>-1</sup>];  $N_{Y_{\text{unfert}}}$  = nitrogen yield of unfertilized plot [kg N ha<sup>-1</sup>];  $\text{BNF}_{\text{fert}}$  = biological N fixation in fertilised plots [kg N ha<sup>-1</sup>];  $\text{BNF}_{\text{unfert}}$  = biological N fixation in unfertilised plots [kg N ha<sup>-1</sup>];  $F_{\text{appl}}$  = fertiliser applied until defoliation n [kg N ha<sup>-1</sup>].

For a comparison of ANRcc and FNR, FNR was also calculated on a cumulative basis by dividing the amount of recovered fertiliser until defoliation n ( $N_{\text{dff}}(n)$  [kg]) by the applied fertiliser until defoliation n:

$$\text{FNRC}(n)[\%] = (\sum N_{\text{dff}}(n) / \sum F_{\text{appl}})$$

with  $N_{\text{dff}}(n) = (N_{\text{dff}}\%_1 + \dots + N_{\text{dff}}\%_j) * N_Y(n)$  where  $N_{\text{dff}}\%_j$  is recovered fertiliser N in total biomass N (%) derived from dressing j;  $N_Y(n)$  = nitrogen yield in defoliation n.

Statistical analysis was performed with the SAS programme PROC MIXED coupled with an autoregressive covariance structure. P-values of main effects were corrected by Tukey-Test whereas P-values of interactions were adjusted according to Bonferroni-Holm. The given data are Least Square Means (LS Means). The critical probability value was  $\alpha=0.05$ .



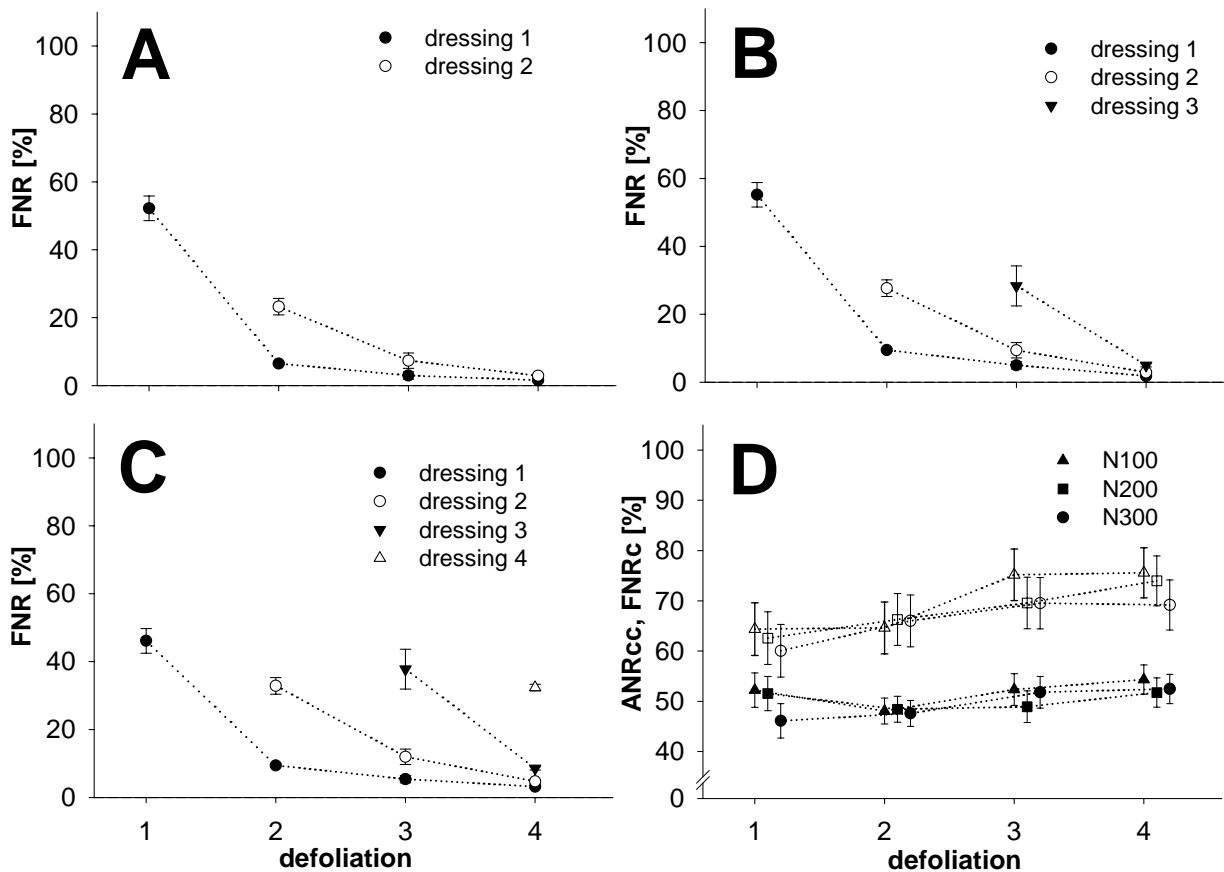

Figure 1: FNR [%] of dressings within the vegetation period in (A) N100, (B) N200, (C) N300; dressings are listed in Table 1. (D) Cumulative FNR (filled symbols) and cumulative corrected ANR (open symbols) for the respective mineral fertiliser treatments within the year. Figures are means of two slurry levels and years. Bars indicate Standard Errors.

## Results and discussion

Annual FNR of mineral fertiliser were 54.3%, 51.7% and 52.5% for N100, N200 and N300 (Figure 1D), but the amount of applied fertiliser and additional slurry did not affect FNR ( $p > 0.05$ ). Highest rates were achieved in the first defoliation (49.7%) and distinctly smaller figures in subsequent regrowths (14.6%, 10.7%, 4.7% in defoliation 2 to 4), differing from each other significantly ( $p < 0.05$ ). This is in accordance to former studies (Jenkinson *et al.*, 2004). But absolute figures in the present study were higher due to the application in split dressings that matched with the demand of the sward. However splitting N rates did not always cause higher recovery rates. When comparing total FNR of the N100 treatment (70/30/./.) with the first dressing of N200 (100 kg N ha<sup>-1</sup>) and the after effect (fig 1A-C), higher FNR for the single dressing of N200 was observed within the year. A similar situation was found with the first two dressings of the N300 treatment compared to the complete dressings of N200. These findings indicate that fertiliser applied in the last two regrowths is less exploited than dressings at the beginning of the vegetation period. Furthermore our data indicate that even initial dressings of 130 kg N ha<sup>-1</sup> did not exceed the demand of a highly productive sward.

Annual ANRcc of mineral fertiliser was higher than FNRC and ranged between 69.2-75.6% with firm effects of DEF and N<sub>SL</sub> (Figure 1D). Differences of both methods were tested and revealed firm effects of DEF as main effect and in interaction indicating that there is no linear relation of ANRcc and FNRC over time.

FNR of slurry was not influenced by mineral fertiliser ( $p > 0.05$ ) and showed highest rates in the first defoliation (9.3-12.2%) (Figure 2).

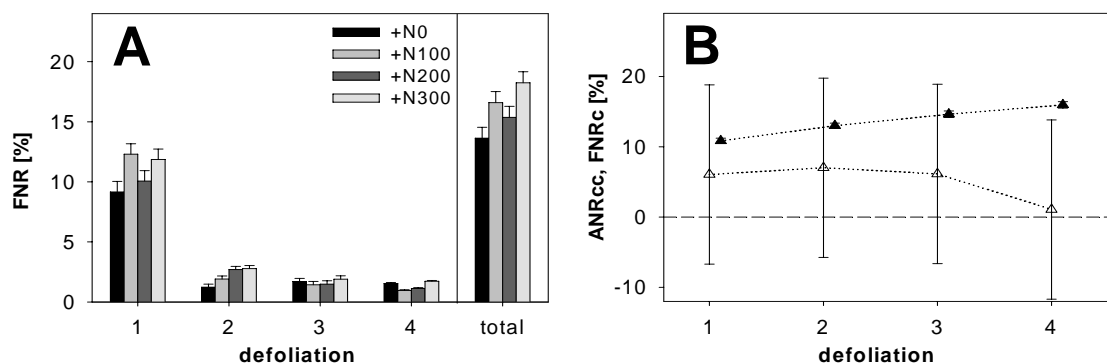

Figure 2: (A) FNR [%] of slurry combined with additional unlabeled mineral fertiliser within the vegetation period and annual recovery rates. (B) Cumulative FNR (filled symbols) and cumulative corrected ANR (open symbols) for slurry over the year. Figures are means of 4 N-treatments. Bars indicate Standard Errors. Standard Errors of FNRc were smaller than symbols.

In subsequent defoliations a sharp decrease occurred with mean recovery rates of 2.2%, 1.6% and 1.3% for defoliation 2 to 4 leading to an annual mean recovery rate of 13.6-18.3% (fig 2A).

Annual ANRcc of slurry ranged between -20% and +29% resulting in an average of 1.1% which is lower than FNRc Figures (Figure 2B). Differences of both methods were tested showing no influences of tested effects which can be led back to high standard errors of ANRcc (Figure 2B). Thus a Bartlett-test proved FNRc to be more precise than ANRcc ( $p < 0.001$ ) for slurry and mineral fertiliser recovery rates.

## Conclusions

According to  $^{15}\text{N}$  data, fertiliser recovery rates of mineral fertiliser and slurry were neither affected by N rate nor by additional N-sources. For slurry, recovery rates of both methods were distinctly lower than assumed in the German Fertiliser Ordinance (Anonymous, 2006). But the long-term build-up of an organic N pool and thus the long-term release of nutrients derived from slurry have to be taken into account.

## References

- Anonymous (2006) Verordnung über die Anwendung von Düngemitteln, Bodenhilfsstoffen, Kultursubstraten und Pflanzenhilfsmitteln nach den Grundsätzen der guten fachlichen Praxis beim Düngen (Düngeverordnung - DüV). Bundesgesetzblatt Jahrgang 2006 Teil 1 Nr.2, ausgegeben zu Bonn am 13. Januar 2006.
- Hauck R.D. and Bremner J.M. (1976) Use of tracers for soil and fertiliser nitrogen research. *Advances in Agronomy*, 28, 219-266
- Jenkinson D.S., Poulton P.R., Johnston A.E., and Powlson, D.S. (2004) Turnover of Nitrogen-15-labeled fertilizer in old grassland. *Soil Science Society of America Journal*, 68, 865-875
- Naumann K. and Bassler R. (1976) Die chemische Untersuchung von Futtermitteln. Methodenbuch Band III. VDLUFA-Verlag, Darmstadt
- Meer van der H.G. (2002) Reducing inputs and losses of nitrogen and energy on dairy farms. Final Report Project AIR3 CT92-0332. 2002. Plant Research International B.V. Wageningen.
- Rao A.C.S., Smith J.L., Parr J.F., and Papendick R.I. (1992) Considerations in estimating nitrogen recovery efficiency by the difference and isotopic dilution methods. *Fertiliser Research*, 33, 209-217
- Trott H.T., Wachendorf M., Ingwersen B., and Taube F. (2004) Performance and environmental effects of forage production on sandy soils. I. Impact of defoliation system and nitrogen input on performance and N balance of grassland. *Grass and Forage Science*, 59, 41-55
- Wagner R.E. (1954) Legume nitrogen versus fertiliser nitrogen in protein production of forage. *Agronomy Journal*, 46, 233-237
- Westhoek H., Berg van den R., Hoop de W., and Kamp van der A. (2004) Economic and environmental effects of the manure policy in The Netherlands: synthesis of integrated ex-post and ex-ante evaluation. *Water Science and Technology*, 49, 109-116.

## Development of indicators to quantify nitrogen rejections of grazing dairy cows according to fertilisation types

Meura S.<sup>1</sup>, Lambert R.<sup>2</sup>, Dufrasne I.<sup>1</sup>, Cabaraux J.-F.<sup>1</sup>, Istasse L.<sup>1</sup> and Hornick J.-L.<sup>1</sup>

<sup>1</sup>*Nutrition Unit, University of Liège, Boulevard de Colonster, 4000 Liège Belgium*

<sup>2</sup>*Ecology Unit, Catholic University of Louvain, Place Croix du Sud, 5 bte1, 1348 Louvain-la-Neuve, Belgium*

### Abstract

Nitrogen (N) rejections are a problem of importance in cattle production. In pasture, the amounts of N rejected by the cattle are large since grass N content exceeds the 'animals' requirements. The present study aims to quantify, with dairy cows in a rotational system, N rejections from urine. The trial paddocks were fertilized with compost, slurry or mineral N and grazed during 7 days by 35 dairy cows in late lactation. Milk urea concentration was determined in tank milk samples every day. Urine samples were taken from each cow at the 3rd and the 5th day after the entry in the grazing plot. Urine N and creatinin were determined to quantify urine N excretion. These observed values were compared to urine N excretion data obtained from dry matter intake and grass N content. The mean observed urine N excretion of 312 g N day<sup>-1</sup> was similar to the mean calculated urine N excretion of 330 g N day<sup>-1</sup>. The correlation between calculated urinary N excretion and observed urinary N excretion was significant (P<0.001; r<sup>2</sup>= 22.4%) and the correlation between observed urinary N excretion and milk urea content tended to be significant (P<0.10; r<sup>2</sup>=60%). From these data, it appears that urine N excretion prediction can be more precise with tank milk urea than with urine N excretion calculated from N intake. This research has to be continued and to be repeated during other grazing periods and with cows at different lactation periods to validate the results.

Keywords: Nitrogen, urine, excretion, grazing, dairy cows

### Introduction

Nitrogen (N) rejections are a problem of importance in cattle production. In pasture, the amounts of N rejected by the cattle are large since grass N allowances are in excess of the animal requirements. The European Community aims to decrease these rejections in order to reduce the generated pollution. The data related on N excretion are important and useful for CAP but can change according to the country. There is a lack of studies with grazing animals to objective N rejection indicators. This is surprising since cows grazed nearly during half of the year.

The present study aims to quantify urine rejections from data obtained on a unique urine sample per cow collected daily at two different days with dairy cows grazed in a rotational system. There were three fertilisation techniques [(slurry (S), compost (C) and mineral N (Min N)]. The obtained urine N rejection was compared with theoretical data.

## Materials and methods

This experiment was carried out in September 2006 on permanent pastures located in the area of Liege in Belgium. A total of 35 cows in late lactation grazed 6 paddocks in a rotational system. Three of these paddocks were used for this trial. Since 2001, the first paddock was fertilized with cattle C, the second with pig S and the third with Min N. During the trial, each paddock was grazed during 1 week. Grass yields were measured just before entry at day 1. Grass height was measured at the entry and the exit of the animals. Grass samples were taken at day 1 and day 4. The cows were milked twice per day and milk productions recorded at each milking. Milk samples were taken at each milking in order to determine N and urea contents. The cows received 1 kg dry sugar beet pulp per day in the milking parlour. The cows were weighed before and after each paddock grazing at day 1 and day 7. A sample of urine was taken between 9 and 10 am on each cow on days 3 and 5. Urinary creatinin was used to estimate daily urinary volume since creatinin is secreted proportionally to the muscular mass at a rate of 100 mg kg<sup>-1</sup>. Creatinin was determined by Jaffe colorimetric method in fresh urine. N was determined in urine by Kjeldahl method and in grass samples by NIRS. The amount of urinary N was calculated from urinary volume and content in urine.

Dry matter intake (DMI) was calculated on basis of energy requirements for maintenance, grazing, milk production and bodyweight change. N excretions in urine were estimated by difference from N intake and excretions by milk and by faeces in order to compare the calculated data to urinary N data observed in this trial. Faeces N was considered as constant and estimated at 7.75 g kg<sup>-1</sup> DMI (Whitehead, 1970; Peyraud *et al.*, 1995).

The data were analysed with a mixed model (proc mixed, SAS, 1999) allowing the inclusion of an autocorrelation between successive measurements made on the same animal within a treatment. The effects of the treatments, the repetition and the interaction between the treatments and repetitions were taken into account in the model.

## Results and discussion

The mean fertilisation inputs per year of N, P<sub>2</sub>O<sub>5</sub> and K<sub>2</sub>O<sub>3</sub> were respectively at 169, 107 and 135 kg ha<sup>-1</sup> in C, 170, 76, 93 kg ha<sup>-1</sup> in S and 102, 31 and 45 kg ha<sup>-1</sup> in Min N. The grass yields per ha before the entry was 1334 kg DM in Min N, 1228 kg DM in S and 1211 kg DM in C. The grass heights are given in Table 1. DM content was lower at day 1 than at day 4 except in C. Grass N content decreased from day 1 to day 4. According to these results, herbage allowances seemed to be lower in C and S as compared with Min N but grass N content was similar between the three fertiliser techniques.

Table 1. Grass heights, DM and N contents in grass and milk urea content in grazed pastures fertilized with different techniques.

	Compost		Slurry		Mineral Nitrogen	
	Day 1	Day 4	Day 1	Day 4	Day 1	Day 4
Height (cm)	11.1	5.7	12.7	8.8	14.6	10.2
DM (g kg <sup>-1</sup> )	17.4	16.8	11.4	16.9	11.2	15.3
N (g kg <sup>-1</sup> )	40	34	44	33	44	36
Milk urea (mg l <sup>-1</sup> )	480	350	415	400	470	490

Daily milk yields were not significantly different (Table 2). The effects of the fertiliser techniques, day and their interactions on N intake were significant but there were no effects on milk N content. Calculated urinary N excretion was significantly different according to the fertilisation techniques, the day and the interaction. Urine volumes and urine N content were also different. The lowest urinary volume was observed in S and was compensated by a

higher N content. By contrast, the highest urinary volume in C corresponded to the lowest N content. The effects of fertilisation techniques and day on observed urinary N excretion were significantly different but the interaction was not significant. The mean observed urinary N excretion from a single sample at  $312 \pm 80$  g N day<sup>-1</sup> was similar to the mean calculated urinary N excretion at  $330 \pm 69$  g N day<sup>-1</sup>. The correlation between calculated urinary N excretion and observed urinary N excretion was significant (Figure 1,  $P < 0.001$ ;  $r^2 = 22.9\%$ ,  $y = 0.5628x + 126.9$ ). From these first results, the prediction of urinary N excretion in grazing dairy cows is possible from calculated DMI and milk N but appeared to be of rather low precision owing to low correlation. The correlation between observed urinary N excretion and tank milk urea content (one value per urine sampling date) tended to be significant (Figure 2,  $P < 0.10$ ;  $r^2 = 51.6\%$ ,  $y = 1,1505x - 141, 6$ ). Tank milk urea concentration, that reflect rumen ammonia concentration and that can be considered as an N rejection indicator, appeared to be a better parameter to predict urinary N excretion.

Table 2. Daily milk yield and N intake in grazed pastures fertilized with different techniques

	C	S	Min N	Day 3	Day 5	Fertiliser effect	Day effect	Interaction effect	AIC
Daily milk yield (kg)	14.2	15.1	15.9	15.1	15.1	NS	NS	NS	870
N intake (g day <sup>-1</sup> )	494	543	570	590	482	***	***	*	1848
Milk N (g day <sup>-1</sup> )	88	91	97	92	92	NS	NS	NS	1476
Urinary N excretion (g day <sup>-1</sup> ) <sup>1</sup>	298	340	358	385	277	***	***	***	1630
Urinary volume (l day <sup>-1</sup> )	49	30	42	47	34	***	***	***	1364
Urinary N content (g l <sup>-1</sup> )	6.3	9.3	9.9	8.0	8.9	***	***	*	669
Urinary N excretion (g day <sup>-1</sup> ) <sup>2</sup>	251	285	388	323	293	***	*	NS	1742

\*\*\*:  $P < 0.001$ , \*:  $P < 0.01$  and NS: non significant.

<sup>1</sup> calculated urinary N excretion from N intake, N faeces and milk N

<sup>2</sup> observed urinary N excretion from urinary volume and urinary N in samples

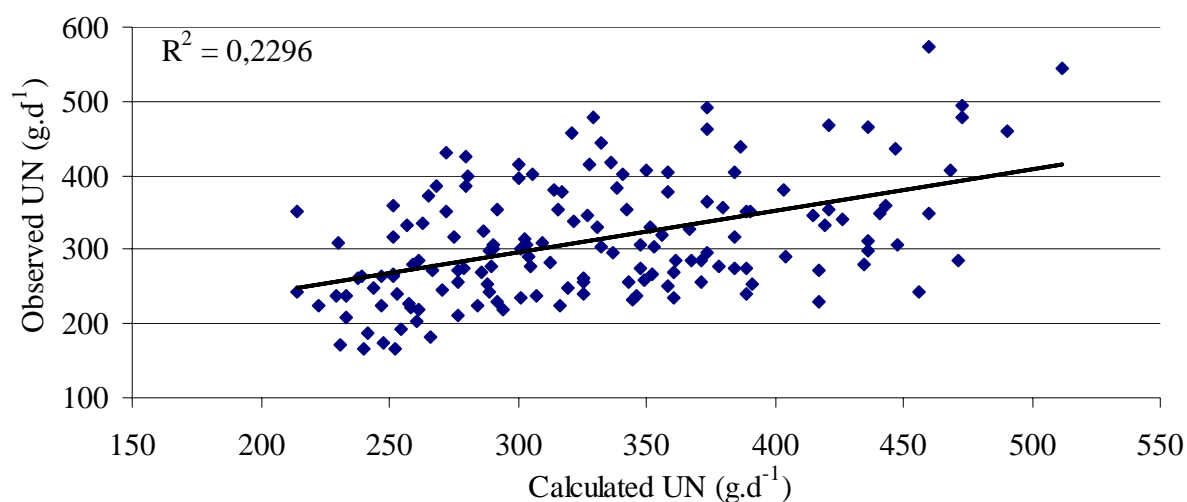

Figure 1. Relationship between calculated N and urinary N excretions (UN: excretion of urinary N)

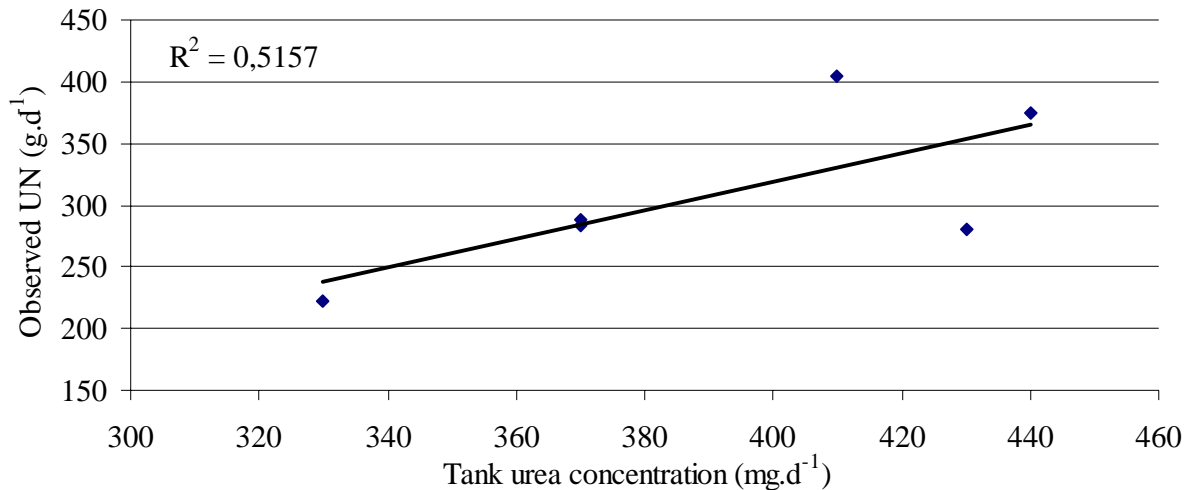

Figure 2. Relationship between tank urea concentration and urinary N excretion (UN)

## Conclusion

From these results, it can be concluded that the data obtained from a unique urine sample per day and per cow can be compared to calculated urinary N excretion from the DMI. The prediction accuracy seems to be low and tank milk urea concentration appears to be a better predictor of observed urinary N for a group of grazing animals. This research has to be continued and to be repeated to validate the results during other grazing seasons and with cows at different lactation periods.

## References

- Peyraud J.L., Vérité R. and Delaby L. (1995) Rejets azotés chez la vache laitière: effets du type d'alimentation et du niveau de production des animaux. *Fourrages*, 142, 131-144.
- Whitehead D.C. (1970) The role of nitrogen in grassland productivity. Bulletin 48, *Commonwealth Agricultural Bureaux*, Farnham Royal Buchs, United Kingdom. 202 pp.

# Residual effects of different organic matters compared with mineral nitrogen on a mown permanent grassland.

Knoden D.<sup>1</sup>, Godden B.<sup>2,3</sup>, Destain J.-P.<sup>3</sup>, Stilmant D.<sup>4</sup> and Luxen P.<sup>1,2</sup>

<sup>1</sup>*Fourrages Mieux, rue du Carmel 1, 6900 Marloie, Belgium*

<sup>2</sup>*Agra-Ost, Klosterstrasse 28, 4780 St-Vith, Belgium*

<sup>3</sup>*Centre Wallon de Recherches Agronomiques Département de Production Végétale, rue du Bordia 4, 5030 Gembloux Belgium*

<sup>4</sup>*Centre Wallon de Recherches Agronomiques Section Systèmes Agricoles, rue de Serpont 100, 6800 Libramont, Belgium*

## Abstract

The effect of four slow acting organic fertilisers (SA: cattle manure, farmyard manure compost, compost of separately collected green refuse and sewage sludge) and three fast acting organic fertilisers (FA: cattle slurry, deep litter fermentation of pig and poultry droppings) was compared with increasing level of mineral nitrogen fertilisation (0, 50, 100, 150, 200 kg N ha<sup>-1</sup> y<sup>-1</sup>). Applications of fertilisers were performed during seven years (1993-2000), on a permanent grassland from the Eastern part of Belgium. In this paper, we focus our attention on the analysis of the residual effects, observed in 2001, i.e. one year after the last application, on forage yield and plant species occurrence. Compared to mineral fertilisation of 200 kg N ha<sup>-1</sup> y<sup>-1</sup> (100%), SA have a better back effect on yield (141%) than FA (135%). After seven years of application, plant species composition was in general better with SA than FA organic fertilisers or mineral fertilisers.

So, using SA organic fertilisers, regularly on grassland, secure the productivity even if there's no fertiliser application during one year.

Keywords: organic fertilisation, residual effect, grassland, nitrogen, yield

## Introduction

In reaction to the evolution of the agricultural market, farmers are looking for alternatives to lower the costs of their productions. In herbivore systems, this means more especially for forage production costs (Szewczyk *et al.*, 2004). To do so, some breeders reduce the use of expensive mineral fertiliser through a better valorisation of organic fertilisers produced on farm or out of it. One potential drawback is that the organic fertilizer, depending of its nature, may not release enough of its principal nutrients when the plant needs them. So it is important to be able to define its effects as a fertiliser in order to take it into account in the global fertilisation scheme, to adjust the applications to the plant needs.

In spite of this difficulty, there is a huge interest to apply organic matters on grasslands as this crop allows several applications per year and are able to export more nutrients than annual crops (Bittman *et al.*, 2004).

In such a context, the objective of this experiment was to compare in the long run, the effectiveness and the residual effects of different organics fertilisers on a mown permanent grassland. The references are the effectiveness and the residual effects observed following the use of different levels of mineral fertilisers.

## Material and methods

This trial was carried out between 1993 and 2001, on a permanent grassland dominated by perennial ryegrass, in the Eastern part of Belgium (about 600 m above sea level, in average (1995-2000) 580 mm of rainfall during the growing season (April-September). An oversowing, with 44 kg/ha of different perennial ryegrass varieties, was carried out in April 1994. The experiment was set up in a randomised block design with 4 replicates. Each experimental plot had a size of 75 m<sup>2</sup> (5 m x 15 m). Four slow acting organic fertilisers (SA: cattle manure (M), composted cattle manure (CM), compost of separately collected green refuse (GC) and sewage sludge (SS)) and three fast acting organic fertilisers (FA: cattle slurry (S), deep litter fermentation of pig (PL) and poultry droppings (PD)) were compared to increasing levels of mineral nitrogen fertilisation (0, 50, 100, 150, 200 kg N ha<sup>-1</sup> y<sup>-1</sup>). Sewage sludge and poultry droppings were only applied since 1996.

The objective was to apply, for each of the organic matter, a total amount of 200 kg N ha<sup>-1</sup> y<sup>-1</sup>, until 2000. To do so, each organic matter was analysed to adjust the N input for the different treatments. Per year, in average for all the organic treatments, 147 kg P<sub>2</sub>O<sub>5</sub> ha<sup>-1</sup> and 90 kg K<sub>2</sub>O ha<sup>-1</sup> were applied under a mineral form to complete organic fertilizers supplies. All mineral treatments received, in average, per year, 155 kg P<sub>2</sub>O<sub>5</sub> ha<sup>-1</sup> and 201 kg K<sub>2</sub>O ha<sup>-1</sup> each year (Table 1). No fertilisation was applied in 2001. Three to four cuts were performed each year. In 2001, dry matter yield (DM) and grass nutritive value were measured for each plot, at each cut for DM and for the 1<sup>st</sup>, 2<sup>nd</sup>, 3<sup>rd</sup> cuts for nutritive value. Botanical composition and species cover were recorded during each year, in September, using B% method (DeVries *et al.*, 1959). Statistical analyses were performed using a two ways ANOVA, with a mixed model (proc GLM – SAS). The two factors taken into account were the ‘treatment’ and the ‘block’. The factor treatment was tested against the interaction ‘treatment\*block’. Multiple means comparisons were performed with Student-Newman-Keuls test.

Table 1: Average annual fertilisation (organic + mineral), during the 1993-2000 period

Treatment	N (kg.ha <sup>-1</sup> .y <sup>-1</sup> )	P <sub>2</sub> O <sub>5</sub> (kg.ha <sup>-1</sup> .y <sup>-1</sup> )	K <sub>2</sub> O
M (SA)	192	257	321
GC (SA)	186	280	241
MC (SA)	202	267	326
SS (SA)	146	338	229
PD (FA)	144	239	220
S (FA)201	213	288	
PL (FA)	225	409	398
N0	0	154	197
N50	50	156	197
N100	101	156	197
N150	150	154	206
N200	197	154	206

## Results and discussion

There were significant DM Yield differences between the treatments during the 2001 season (Table 2). Except for PL, all the Slow Acting fertilisers (SA) give better DM yield than FA and mineral fertilisers. In 2001, SA fertilizers keep or even increase their 7 years (1993-2000) average DM yield (6829 kg.ha<sup>-1</sup> vs 6705 kg.ha<sup>-1</sup>). When comparing the treatments M and S, the most widely used on grassland, to the mineral fertilisation schemes of 150 and 200 kg N ha<sup>-1</sup> y<sup>-1</sup> (100%), we observed that M has the better back effect on DM (149%) (F(1,33) =



44.22;  $p < 0.001$ ) and on energy (146%) [ $F(1,33) = 41.84$ ;  $p < 0.001$ ] yields while S has an intermediate position with, respectively, 125% [ $F(1,33) = 9.85$ ;  $p < 0.005$ ] and 122% [ $F(1,33) = 8.23$ ;  $p < 0.005$ ] of the performances observed with mineral fertilisation schemes.

These results could be explained by the increase of the efficiency of the organic dressings from year to year, especially for the SA. To explain the big DM yield drop of N200 treatment, we draw the hypothesis of a  $K_2O$  sub-fertilisation during 7 years (Table 1). A second observation supporting this hypothesis is the weak protein value of N200 ( $104 \text{ g kg}^{-1}$ ) and N150 ( $109 \text{ g kg}^{-1}$ ) compared to the organic treatments. An future analysis of the N, P and K nutritive indexes (Lemaire *et al.*, 1997) will allow to test this hypothesis.

There is no significant difference between treatments in terms of energy content in the grass. So, the differences observed in term of energy production result from the difference recorded for DM yield.

Table 2: Annual dry matter yield [DM] ( $\text{t ha}^{-1}$ ), energy production ( $10^6 \text{ VEM}$ ) and crude protein content ( $\text{g kg}^{-1} \text{ DM}$ ) from the different treatments for 2001. Value marked by different letters within the same column are significantly different ( $p < 0.05$ ).

Treatment ( $\text{t.ha}^{-1}$ )	DM (% of N200)	DM ( $10^6 \text{ VEM ha}^{-1}$ )	Energy ( $\text{g kg}^{-1} \text{ DM}$ )	Protein
PL (FA)	7600 <sup>a</sup>	157	7.26 <sup>a</sup>	122 <sup>a</sup>
M (SA)	7194 <sup>ab</sup>	149	6.74 <sup>ab</sup>	119 <sup>a</sup>
GC (SA)	6953 <sup>abc</sup>	144	6.62 <sup>abc</sup>	122 <sup>a</sup>
MC (SA)	6678 <sup>abcd</sup>	138	6.39 <sup>abc</sup>	121 <sup>a</sup>
SS (SA)	6491 <sup>bcd</sup>	134	6.07 <sup>bc</sup>	113 <sup>ab</sup>
N0 6399 <sup>bcd</sup>	132	6.07 <sup>bc</sup>	118 <sup>ab</sup>	
PD (FA)	6062 <sup>bcd</sup>	125	5.71 <sup>bcd</sup>	110 <sup>ab</sup>
S (FA) 6041 <sup>bcd</sup>	125	5.64 <sup>bcd</sup>	111 <sup>ab</sup>	
N50 5922 <sup>cde</sup>	122	5.65 <sup>bcd</sup>	121 <sup>a</sup>	
N100 5713 <sup>def</sup>	118	5.50 <sup>cd</sup>	113 <sup>ab</sup>	
N150 5178 <sup>ef</sup>	107	4.92 <sup>de</sup>	109 <sup>ab</sup>	
N200 4843 <sup>f</sup>	100	4.60 <sup>e</sup>	104 <sup>b</sup>	

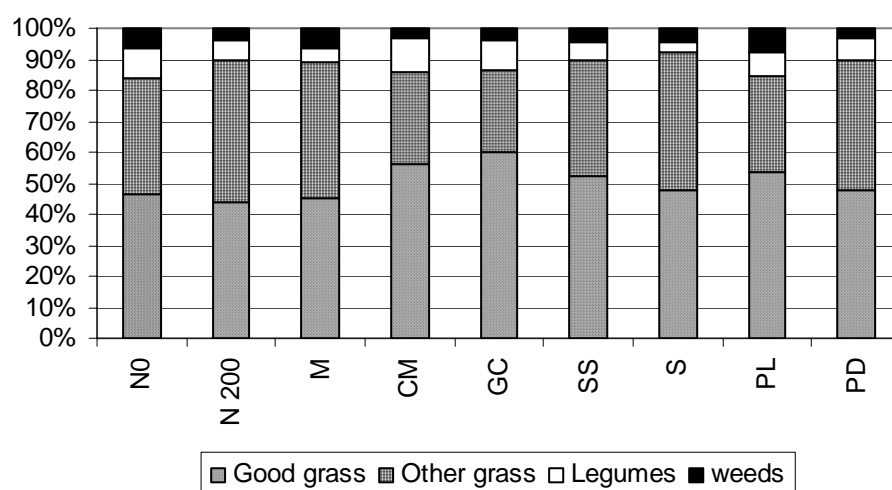

Figure 1 : Botanical composition (B%) in 2001 for SA, FA, N0 and N200 treatments

In Figure 1, classification of the botanical composition was made with De Vries method (1942). In this case, *Lolium perenne*, *Festuca patrensis*, *Phleum patrense* and *Poa patrensis* are considered as good grass. After 7 years of application of the different fertilisation schemes, the percentage of good grass and legumes is the highest for the 2 composted

matters: CM and GC. Legumes percentage is not higher in N0 treatment (10%) than in the CM and GC (11.5 vs 10%). The application of M and furthermore of S does not stimulate the development of legumes (5% vs 3.8%). These results underline the real interest to compost manure before its application on grassland. Compare to M, the flora observed following the application of CM integrates 11% more of good grass, 6.5% more of legumes, essentially white clover, and 3.3% less weeds.

## **Conclusions**

These results confirm that organic fertilizers have a larger residual effect than mineral ones. This is especially true for SA fertilizers. So, a regular dressing of organic matter on mown permanent grasslands secure DM and protein yields through an increase of nitrogen supplying by the soil, in comparison to mineral fertilisation schemes. In addition, botanical composition of the sward is the same and even better following organic fertilisation schemes especially for composted organic matters, at least if the applications are done under good conditions.

## **Acknowledgement**

This research was supported by the Ministry of the Walloon region (MRW-DGA).

## **References**

- Bittman S., Kowalenko C.G., Hunt E., Bounaix F., Forge T. (2004) Effect of multi-year surface-banding of dairy slurry on grass. *Proceedings of the 11<sup>th</sup> International conference of F.A.O. ESCORENA, Sustainable organic waste management for environmental protection and food safety*, Murcia, 47-51.
- De Vries D.M. et De Boer (1959) Methods used in a botanical grassland research in the Netherlands and their applications. *Herbage Abstracts*, 29 (1).
- Lemaire G. (1997), *Diagnosis of the nitrogen status in crops*, Springer Verlag, Berlin, 3-44.
- Szewczyk W., Kasperczyk M. and Kacorzyk P. (2004) Role of farmyard manure on upland meadows. *Proceedings of the 20<sup>th</sup> General Meeting of the EGF, Land use systems in grassland dominated regions*, British Grassland Society, Luzern, 714-716.

# Effect of legume catch crops management on the dynamics of soil mineral nitrogen and nitrate leaching

Arlauskienė A. and Maikštėnienė S.

*Joniškėlis Research Station of the Lithuanian Institute of Agriculture,  
Joniškėlis, LT-39301 Pasvalys District, Lithuania*

## Abstract

Seeking to estimate the effects of biological measures – various legume catch crops in combination with incorporation of cereal straw on the reduction of soil nitrogen leaching, complex research was conducted at the Lithuanian Institute of Agriculture's Joniskėlis Research Station on an *Endocalcari* – *Endohypogleyic Cambisol* during the period 2003-2005. In the autumn with a high rainfall rate during the post-harvest period of primary crops, undersown red clover (*Trifolium pratense* L.) and mixture of white clover (*Trifolium repens* L.) and Italian ryegrass (*Lolium multiflorum* Lamk.) reduced  $N_{\min}$  content in the soil as well as the risk of leaching by 13.7 and 17.1%, respectively compared with the treatment without catch crops. Low contents of  $N_{\min}$  are found in heavy-textured *Cambisols* in spring, higher contents of  $N_{\min}$  in the soil and filtration water were found in the treatments where nitrogen-rich biomass of legume crops was incorporated in the autumn, having incorporated it together with straw,  $N_{\min}$  content in the soil significantly declined.

Keywords: clay loam *Cambisol*, legume catch crop, soil mineral nitrogen, leaching

## Introduction

Numerous studies have been done and recommendations have been provided on the most suitable fertiliser forms and rates, application timing and methods. However, research on the effects of the technologies used on nutrient, especially nitrogen, immobilisation in the soil after harvesting of main crops, when the soil during the post-harvest period stays without any plant cover for a long time, is rather scarce. Seeking to reduce environmental pollution, very important is adequate selection of preventive measures when including the nutrients not utilised by plants into biological turnover cycle (Hansen *et al.*, 2000; Antil *et al.*, 2005). With this end in view, technologies with catch crops that accumulate and localize in the soil the nutrients left in biomass at the end of summer – during the autumn (winter) period, and during the most intensive leaching complex prevent the nutrients from being leached, are widely used in Western Europe. Under the effect of biological transformation the incorporated biomass in the following year becomes nutrient source for crops grown (Thorup-Kristensen *et al.*, 2003; Farthofer *et al.*, 2004).

## Materials and methods

Two bi-factorial trials designed to explore the feasibility of reducing nitrogen leaching through cultivation of catch crops and straw utilisation, were carried out at the Lithuanian Institute of Agriculture's Joniskėlis Experimental Station (trials period 2003-2004 and 2004-2005). The soil of the northern part of Central Lithuania's lowland *Endocalcari* – *Endohypogleyic Cambisol* (*Cmg-n-w-can*), according to texture- heavy loam on silty clay with deeper lying sandy loam (*p2/m2/p1*). The soil agrochemical properties in the 0–20 cm layer were as follows:  $pH_{KCl}$  – 6.4; humus – 2.1-2.2%; plant available  $P_2O_5$  and  $K_2O$  – 118-

120 and 240-265 mg kg<sup>-1</sup> of soil respectively. Experimental design: Factor A: Straw management methods: I. Straw - removed from the field; II. Straw - chopped and incorporated. Factor B: Stubble breaking and catch crops: 1. Stubble not broken; 2. Stubble broken by combined stubble breakers; 3. Undersown catch crops – red clover (*Trifolium pratense* L.; 4. Undersown catch crops – mixture of white clover (*Trifolium repens* L.) and Italian ryegrass (*Lolium multiflorum* Lamk.); 5. Undersown catch crops – white mustard (*Sinapis alba* L.) broadcast-sown into winter wheat at wax maturity stage; N45 was applied after winter wheat harvesting for optimal growth and development of white mustard. In order to create optimal conditions for the mineralization of incorporated straw, 8 kg ha<sup>-1</sup> of nitrogen was applied after straw chopping and spreading. Mineral nitrogen (NO<sub>3</sub> + NH<sub>4</sub>) (layer 0-40 cm) was measured by distillation and colorimetry method (in 1 N KCl extraction). In water samples N-NO<sub>3</sub> and N-NH<sub>4</sub> contents were determined calorimetrically by the analyser 'FIA Star 5012 system', NH<sub>4</sub>-N – by gas diffusion and N-NO<sub>3</sub> – by cadmium reduction methods.

## Results and discussion

Cultivation of catch crops as undersowings or postcrops and their incorporation into the soil as green manure makes it possible to include mineral nitrogen into biological nutrient turnover cycle by retaining it in the ploughlayer (Table 1).

Table 1. Mineral nitrogen content (mg kg<sup>-1</sup> soil) in the soil before incorporation (0-40 cm) of biomass of catch crops.

Stubble breaking and catch crops (B)	Straw management methods (A)					
	without straw			addition of chopped straw		
	NO <sub>3</sub>	NH <sub>4</sub>	N <sub>min.</sub>	NO <sub>3</sub>	NH <sub>4</sub>	N <sub>min.</sub>
Stubble not broken	3.3	3.7	7.0	3.2	4.4	7.6
Stubble broken by combined breakers	3.0	3.6	6.6	3.6	4.0	7.6
Catch crops – red clover	2.8	3.3	6.1	3.0	3.5	6.5
Catch crops – white clover+Italian ryegrass	2.9	3.4	6.3	2.7	3.1	5.8
White mustard broadcast - sown	3.3	3.3	6.6	2.8	3.8	6.6
Average	3.1	3.4	6.5	3.1	3.7	6.8
LSD <sub>05</sub> fact. A	0.18	0.27	0.30			
LSD <sub>05</sub> fact. B	0.33	0.51	0.57			
LSD <sub>05</sub> fact. AB	0.47	0.72	0.80			

Experiments carried out early in October before incorporation of catch crops into the soil show that the content of mineral nitrogen in the upper (0-40 cm) soil profile was on average through all experimental treatments 6.7 mg kg<sup>-1</sup>soil. Nitrate and ammonia nitrogen accounted for 46.3 and 53.7% of its content. On the field with straw, having spread mineral nitrogen fertiliser for its more rapid mineralization, N<sub>min.</sub> tended to increase. Having incorporated cereal roots and stubble at 10-12 cm by stubble breakers, the contents of both nitrate and ammonia nitrogen declined, which determined a reduction in mineral nitrogen content of 5.7 %, compared with that in the treatment with unbroken stubble. On both fields (without straw and with added straw) undersown legumes significantly increased revivification of mineral nitrogen (NO<sub>3</sub> and NH<sub>4</sub>) in the soil profile. Undersown grasses grown as catch crops have a well-developed root system, as a result, after cereal harvesting they better utilised nitrogen remaining in the soil compared with white mustard as postcrop, moreover they do not need mineral nitrogen fertilisers. Before incorporation of catch crops biomass there was less mineral nitrogen on both fields of straw management methods where red clover and mixture of white clover and ryegrass was grown, which made up 13.7 and 17.1% less, compared with the check treatment. White mustard undersown at cereal milk maturity (and having incorporated the start dose of mineral nitrogen fertiliser), was at intensive nutrient utilisation

stage, therefore better utilised both soil and mineral fertiliser nitrogen and reduced  $N_{\min}$  in the soil by average 9.6%, compared with the check treatment.

In spring after incorporation of catch crops biomass and straw the content of nitrogen in heavy-textured soil at the 0-40 cm layer was found to be almost the same as in autumn – 6.9 mg kg<sup>-1</sup> soil or 27.2 kg ha<sup>-1</sup> (Table 2). In spring ammonia nitrogen accounted for the larger share (59.1 %) than nitrate nitrogen (40.9%) in total mineral nitrogen. At the beginning of the plant growing season mineral nitrogen varied in a slightly different way than in autumn. The greatest increase in  $N_{\min}$  content in the soil occurred after incorporation of red clover and mixture of white clover and ryegrass. This results from the fact that during the period of autumn, winter and early spring during the breakdown of incorporated biomass of legumes, higher content of nitrogen is released compared with that after incorporation of non-legume catch crops.

Table 2. The effect of various catch crops and incorporation their biomass and straw on the accumulation of mineral nitrogen in the soil (mg kg<sup>-1</sup>) in spring (0-40 cm).

Stubble breaking and catch crops (B)	Straw management methods (A)					
	without straw			addition of chopped straw		
	NO <sub>3</sub>	NH <sub>4</sub>	N <sub>min.</sub>	NO <sub>3</sub>	NH <sub>4</sub>	N <sub>min.</sub>
Stubble not broken	3.1	4.4	7.5	2.9	4.0	6.9
Stubble broken by combined breakers	3.0	3.8	6.8	2.7	4.2	6.9
Catch crops – red clover	3.0	4.1	7.1	2.7	4.0	6.7
Catch crops – white clover+Italian ryegrass	2.9	4.5	7.4	2.4	3.7	6.1
White mustard broadcast - sown	2.5	3.7	6.2	2.6	3.9	6.5
Average	2.9	4.1	7.0	2.7	4.0	6.7
LSD <sub>05</sub> fact. A	0.18	0.19	0.23			
LSD <sub>05</sub> fact. B	0.34	0.35	0.42			
LSD <sub>05</sub> fact. AB	0.48	0.49	0.60			

After incorporation of biomass red clover, white clover and ryegrass mixture,  $N_{\min}$  increased by 16.4 and 17.5%, compared with analogous data in autumn. Straw incorporation reduced its content by 5.6 and 17.6 %. Having incorporated non-legume crop – white mustard the content of mineral nitrogen declined on both fields of straw management methods, which is indicated by other authors (Reents *et al.*, 2000). After straw incorporation a significant reduction in nitrate nitrogen and  $N_{\min}$  contents occurred compared with the treatments where straw was removed. Here the content of mineral nitrogen was by 4.3% lower. Non-legume catch crop, white mustard, significantly reduced (11.1%) mineral nitrogen content in the soil, whereas legumes tended to increase mineral nitrogen.

Mineral nitrogen content in the soil profile in spring had some effect on nitrogen concentration in soil filtration water (Table 3).

Table 3. Nitrogen leaching (mg l<sup>-1</sup>) from the soil occupied with various catch crops (0-80 cm)

Stubble breaking and catch crops (B)	Straw management methods (A)					
	without straw			addition of chopped straw		
	NO <sub>3</sub>	NH <sub>4</sub>	N <sub>min.</sub>	NO <sub>3</sub>	NH <sub>4</sub>	N <sub>min.</sub>
Stubble not broken	6.1	0	6.1	7.8	0.9	8.7
Undersown legume catch crops	15.5	0.8	16.3	12.0	0.9	12.9
Aftercrop catch crops - white mustard	13.0	0	13.0	8.2	1.5	9.7
Average	11.5	0.3	11.8	9.3	1.1	10.4
NO <sub>3</sub> LSD <sub>05</sub> fact. A-2.65; fact. B-3.25; fact. AB-4.59						
N <sub>min.</sub> LSD <sub>05</sub> fact. A-2.33; fact. B-2.85; fact. AB-4.03						

On both fields of straw management methods nitrate nitrogen content was significantly increased by the biomass of legume crops incorporated in the autumn. As literature sources indicate, nitrate nitrogen depends on the nitrogen content accumulated in catch crops biomass, and according to nitrogen content in soil solution the plants can be ranked in the following order: legumes > legume-non-legume mixture > non-legumes (Rinnofner *et al.* 2005). The use of straw for fertilisation reduced (11.9%) nitrate nitrogen content in filtration soil solution. Having incorporated straw, after legume crops, the content of mineral nitrogen in filtration water declined by 20.9% and after white mustard by 25.4%, compared with analogous treatments without straw. This nitrate nitrogen concentration in soil filtration water is not high. The data of long-term experiments conducted in Lithuania suggest that average nitrate nitrogen concentration in lysimetric water of different soils ranged from 49.2 to 83.7 mg l<sup>-1</sup> (Tyla, 1995).

## Conclusions

Catch crops with legume crops are an important preventive agromeans against nitrogen accumulation in the soil, and consequently, against its leaching into ground water. Undersown legume crops red clover (*Trifolium pratense* L.), white clover (*Trifolium repens* L.) and Italian ryegrass (*Lolium multiflorum* Lamk.) mixture during the post-harvest period gave the largest reduction in mineral nitrogen in the soil. In spring higher contents of N<sub>min</sub> in the soil and filtration water were found in the treatments where nitrogen-rich biomass of legume crops was incorporated in the autumn, having incorporated it together with straw, N<sub>min</sub> content in the soil significantly declined.

## References

- Antil R. S., Gerzabek M. H., Haberhauer G. and Eder G. (2005) Long-term effects of cropped vs. fallow and fertilizer amendments on soil organic matter II. Nitrogen. *Journal of Plant nutrition and Soil Science*, 168 (2), 212-218.
- Farthofer R., Friedel J.K., Pietsch G., Rinnofner T., Loiskandl W. and Freyer B. (2004) Plant biomass nitrogen and effects on the risk of nitrate leaching of intercrops under organic farming in Eastern Austria. In: Prüß A. (ed.):Eurosoil. *Conference Proceeding*, Sept. 4-12, 2004, Freiberg, Germany
- Hansen B., Kristensen E.S., Grant R., Høgh-Jensen H., Simmelsgaard S.E. and Olesen J.E. (2000) Nitrogen leaching from conventional versus organic farming system – a systems modelling approach. *European Journal of Agronomy*, 13 (1), 65-82.
- Rinnofner T., Farthofer R., Friedel J.K., Pietsch G., Loiskandl W. and Freyer B. (2005) Stickstoffaufnahme und Biomasseertrag von Zwischenfruchten und deren Auswirkungen auf Bodennitratgehalte und die Folgekultur unter den Bedingungen des Ökologischen Landbaus im pannonischen Klimagebiet. In: Heß J., Rahmann G. (hrsg.) Ende der Nische. *Beitrag zur 8. Wissenschaftstagung Ökologischer Landau, März 1-4, Kassel, Germany*, ss. 249-252.
- Thorup-Kristensen K., Magid J. and Jensen L.S. (2003) Catch crops and green manures as biological tools in nitrogen management in temperate zones. *Advances in Agronomy*, 79 pp. 227-301.
- Tyla A. (1995) Cheminių medžiagų migracija įvairiuose Lietuvos dirvožemiuose. *Žemdirbystė: mokslo darbai*, 50, 65-73.

## Effect of timing of grassland destruction on nitrogen mineralization kinetics

Besnard A.<sup>1</sup>, Laurent F.<sup>2</sup>, Hanocq D.<sup>3</sup>, Vertès F.<sup>4</sup>, Nicolardot B.<sup>5</sup> and Mary B.<sup>6</sup>

<sup>1</sup>ARVALIS - Institut du Végétal, La Jaillière, 44370 La Chapelle St Sauveur, (France)

<sup>2</sup>ARVALIS - Institut du Végétal, 91720 Boigneville, (France)

<sup>3</sup>Pôle Agronomie Production Végétale, Chambres d'Agriculture de Bretagne, 8 rue Jean - Marie Le Gall, 29393 Quimperlé Cedex, (France)

<sup>4</sup>INRA UMR Sol Agronomie Spatialisation - 4 rue de Stang Vihan, 29000 Quimper (France)

<sup>5</sup>INRA - Unité d'Agronomie de Laon-Reims-Mons - 2, esplanade Roland Garros, 51686 Reims Cedex 2 (France)

<sup>6</sup>INRA - Unité d'Agronomie de Laon-Reims-Mons – rue Fernand Christ, 02007 Laon Cedex (France)

### Abstract

The objectives of this study (located in Kerlavic (Brittany, France)) were: i) to compare two methods for assessing N mineralization: monitoring soil mineral N and modelling vs. establishing a N balance during three following crops, and ii) to test whether the timing of destruction of grassland (autumn vs. late winter) modifies N mineralization kinetics.

Method 1. The crop successions compared were: rapeseed-wheat-rapeseed, wheat-rapeseed-wheat, maize + catch crop. They followed grassland, destroyed in August 2002, October 2002 and February 2003, respectively. No N fertilizer was applied to the crops.

Method 2. Soils were kept bare after the grassland was destroyed (in September 2002 or February 2003) until March 2005. During this period water and mineral nitrogen contents in soil were measured monthly. These measurements were used in the LIXIM model to calculate N mineralization and leaching fluxes.

N mineralization kinetics determined by both methods were in good agreement. They showed two-phase kinetics (confirming previous results): an intense mineralization for about one year, followed by a much slower mineralization rate. N mineralization was not affected by the date of grassland destruction and reached 500-600 kg N/ha after 2 years.

Keywords: grassland destruction, N mineralization, N fertilisation, ley-arable rotations

### Introduction

In sustainable agriculture it is important to understand the kinetics of nitrogen mineralization after destruction of grassland in order to adapt nitrogen fertilisation rates for the following crop so as to reduce the risk of nitrogen leaching. In earlier experiments (BESNARD *et al.*, 2004), we established the kinetics of nitrogen mineralization after destruction at the end of winter from monthly measurements of soil mineral nitrogen in plots maintained under bare soil for two years. The objectives of this new experiment were: i) to compare two methods of measuring mineral nitrogen after destroying the grass (method 1: monitoring soil mineral nitrogen and calculation of the leaching and the nitrogen mineralization with the LIXIM model ((Mary *et al.*, 1999) v.s. method 2: calculation of the nitrogen balance during the three following crops. ii) to measure the effect of the timing of the destruction of the grass (autumn vs end of winter) on the soil organic nitrogen mineralization kinetics.

## Materials and methods

The experiment is situated at the experimental station at Kerlagic (Brittany, France). The soils are sandy silt loams with free drainage. The perennial ryegrass pasture (*Lolium perenne L.*) was 6 years old when ploughed up. The experiment included 5 treatments (3 replicates), all equipped with ceramic cups to measure nitrate leaching. Table 1 gives details of the treatments.

Table 1 : Experimental treatments after destroying the grass.

Treatment number	Date of grassland destruction	Crop succession			End of trial
		2002-2003	2003-2004	2004-2005	
T1	14/09/2002		bare fallow		
T2	07/09/2002	rapeseed	wheat	rapeseed	11
T3	11/10/2002	wheat	rapeseed	wheat	March
T4	21/02/2003		bare fallow		2005
T5	21/02/2003		maize + catch crop	maize + catch crop	

Grassland destruction was performed chemically with glyphosate. For T1 and T4 the plots were then kept bare until March 2005 by the addition of herbicides 4 times per year, without any soil disturbance. The crops (T2, T3 and T5) were planted after ploughing and received no nitrogen fertilizer. In order to minimise nitrogen losses by leaching, the volunteer rape plants were left until sowing the wheat and a catch crop (Italian ryegrass) was sown after harvesting the maize and destroyed on the following 15 February.

Method 1: To measure the nitrogen mineralization in the plots under bare soil (T1 and T4) 8 soil cores were taken every 3 or 4 weeks to a depth of 80 or 90 cm. Three layers (0-25, 25-50 and 50-80 cm) were distinguished and analysed for NO<sub>3</sub>, NH<sub>4</sub> and water content in triplicate. We then used these results as input data for the LIXIM model in order to calculate the rates of N mineralization and leaching, assuming that these are the dominant processes affecting N in bare soil. LIXIM is a layered, functional model, with a daily time step. Input data also include weather conditions and simple soil characteristics. The variations in N mineralization with temperature and moisture are accounted for, providing calculation of the 'normalized time'. An optimization routine is used to estimate the actual evaporation and the N mineralization rates that provide the best fit between observed and simulated values of water and nitrate contents in all measured soil layers.

Method 2: For the cropped plots (T2, T3 et T5) the net mineralization is calculated at each measurement date from the residual soil mineral N as follows:

MIN net (N-NO<sub>3</sub>) = variation in the mineral N store in the soil + variation of the leached N + variation of the N absorbed by the crop.

The kinetics of mineralization were fitted using a bilinear model to take the two observed mineralization phases into account:

$$M = Rp1.D1 + Rp2.(Dn - D1)$$

where: M : net cumulative mineralization; Rp1, Rp2: respectively, mineralization rates during phase 1 and 2 in kg N ha<sup>-1</sup> ND<sup>-1</sup> with ND = normalized days; Jn, J1: respectively, dates (in normalized days ) after grassland destruction and during phase 1.

## Results and discussion

The LIXIM model was able to reproduce accurately the water content and the mineral N in soil during the two years' experiments (results not shown). The mean RMSE between observed and simulated values were 12.9 and 18.9 kg N ha<sup>-1</sup> for autumn and late winter destruction, respectively. For the bilinear model the mean RMSE between observed and



simulated values (method 1 or method 2) fell between 14.5 and 17.3 kg N ha<sup>-1</sup>. They were comparable to the standard errors of the measurements.

The kinetics of N mineralization obtained by the two methods were fairly similar (Figure 1 a and b). The kinetics were composed of two successive phases (confirming previous results) (BESNARD *et al.*, 2004): rapid mineralization during phase 1 over a period of 87-237 'normalized' days; slow mineralization in phase 2, the mineralization rate (*Rp2*) being 2 to 3 times smaller than in phase 1 (*Rp1*) (Table 2). Comparing the mineralization rates *Rp1* and *Rp2* with those calculated in other fields without grassland during the last 20 years suggested that phase 2 could correspond to a return to the 'basal' mineralization of the soil organic matter.

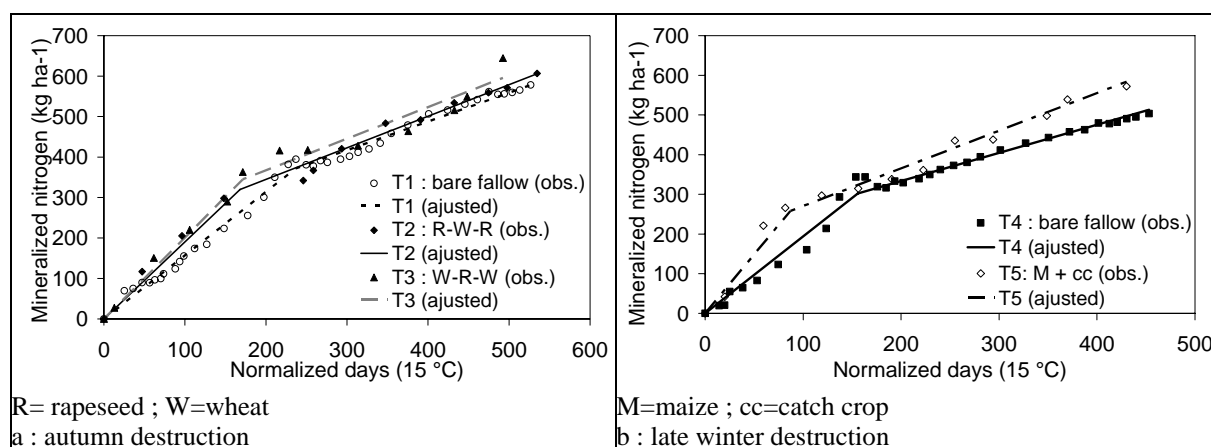

Figure 1: Nitrogen mineralization kinetics established using two methods

Table 2 : Values of fitting variables of the kinetics

	Autumn destruction			Late winter destruction	
	T1	T2	T3	T4	T5
	bare fallow	rapeseed wheat rapeseed	wheat rapeseed wheat	bare fallow	maize + catch crop
Rp1 (kg N ha <sup>-1</sup> ND <sup>-1</sup> )	1.57	1.90	2.01	1.94	2.96
Rp2 (kg N ha <sup>-1</sup> ND <sup>-1</sup> )	0.71	0.78	0.78	0.71	0.95
J1 (ND)	237	168	171	156	87

ND : normalized day

The values obtained in this experiment were in agreement with all the values obtained previously at 7 sites ( LAURENT *et al.*, 2003).

After destruction in the autumn the quantities of nitrogen mineralized over 2,5 years, calculated with method 1 (bare soil) or with method 2 (balance under crop) are similar (557 and 600 kg N ha<sup>-1</sup> respectively). Likewise the quantities of mineralized N resulting from the destruction of the grassland [(*Rp1* - *Rp2*) \* duration *phase 1*] calculated by the two methods are fairly similar: 204 kg N ha<sup>-1</sup> with method 1 and 189 and 211 kg N ha<sup>-1</sup> with method 2, for the rape-wheat-rape (T2) and the wheat-rape-wheat (T3) successions respectively.

After destruction at the end of winter, the quantity of nitrogen mineralized over 2 years with method 1 is 80 kg N ha<sup>-1</sup> less than that calculated with method 2. This results from a

mineralization rate calculated with method 1 which is  $1 \text{ kg N ha}^{-1}$  less than that calculated with method 2, even though the duration of this phase is only about half as long and the mineralization rate in phase 2 calculated with method 1 is 25% less than that calculated with method 2. On the other hand the quantities of mineralized N arising from the destruction of the grassland calculated by the two methods are fairly similar:  $191 \text{ kg N ha}^{-1}$  with method 1 and  $175 \text{ kg N ha}^{-1}$  with method 2. Figure 2 summarises the kinetics of mineralization obtained with method 1 after destruction in the autumn and at the end of winter.

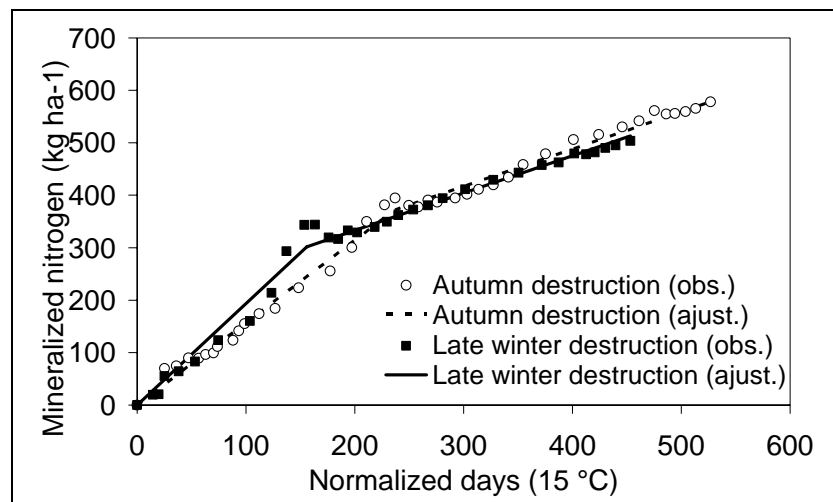

Figure 2 : Nitrogen mineralization kinetics in bare fallows after autumn or late winter destruction

The quantities of mineralized N arising from the destruction of the grassland are quite similar:  $204 \text{ kg N ha}^{-1}$  after autumn destruction and  $191 \text{ kg N ha}^{-1}$  after destruction at the end of winter. However the rates of mineralization are different: after autumn destruction the rate in phase 1 is less than after destruction at the end of winter, but the duration of phase 1 is longer.

## Conclusion

Finally, the results obtained during this present experiment will provide good references to adjust N fertilisation in ley-arable rotations and consequently to reduce the risks of nitrate losses after grassland destruction.

## References

- Besnard A., Laurent F., Kerveillant P., Vertès F., Mary B. and Recous S. (2004) Nitrogen mineralization kinetics after destruction of grazed swards : effects of preceding grassland management.
- Laurent F., Kerveillant P. and Besnard A. (2003) Effet de la destruction de prairies pâturées sur la minéralisation de l'azote: approche au champ et propositions de quantification. Synthèse de 7 dispositifs expérimentaux. ARVALIS - Institut du Végétal, F, 72 pp.
- Mary B., Beaudoin N., Justes E. and Machet J.M. (1999) Calculation of nitrogen mineralization and leaching in fallow soil using a simple dynamic model. *Eur. J. Soil Science*, 50: 549-566.

# Decomposition of cut and returned grass in turfgrass and grass-clover sward

Kauer K., Köster T., Raave H., Viiralt R. and Selge A.

*Estonian University of Life Sciences, Institute of Agricultural and Environmental Sciences, Kreutzwaldi 64, 51014 Tartu, Estonia*

## Abstract

The aim of this research was to study the decomposition of turfgrass clippings and returned grass material of grass-clover laid on the sward and its effect on the sward's productivity at different nutrition regimes.

The study was carried out on turfgrass (seed mixture composition *Festuca rubra* 50% and *Poa pratensis* 50%) and grass-clover sward (*Phleum pratense* 34%, *Lolium perenne* 38% and *Trifolium repens* 28%). Experimental treatments for turfgrass sward were N<sub>0</sub>P<sub>0</sub>K<sub>0</sub>, N<sub>80</sub>P<sub>11</sub>K<sub>48</sub>, N<sub>160</sub>P<sub>22</sub>K<sub>96</sub> and N<sub>400</sub>P<sub>56</sub>K<sub>240</sub> and for grass-clover sward N<sub>0</sub>P<sub>0</sub>K<sub>0</sub> and N<sub>80</sub>P<sub>26</sub>K<sub>50</sub>. The turfgrass sward was cut 15-20 times and grass-clover sward 3-5 times at a height of 5 cm during the growing season. The clippings of the turfgrass and the cut grass of grass-clover were either removed after cutting or returned to the plots.

The speed of decomposition varied; the weight loss of plant material of turfgrass increased from 43.9% (by end of week 2) to 61.9% (by end of week 8) while the weight loss of plant material of grass-clover increased from 20.8% (by end of week 2) to 47.8% (by end of week 8). Fertilization of swards did not affect the decay of returned grass.

Keywords: turfgrass, grass-clover sward, clippings, decomposition, litterbags method

## Introduction

The returning of grass clippings provides a biodegradable source of organic N to the turfgrass ecosystem (Busey and Parker, 1992). The decomposition rate of grass clippings varies with a number of factors, including the nature of the plant material, the available decomposer microbe community, temperature and moisture conditions (Mary *et al.*, 1996). The initial concentration of N is the main factor limiting the growth of the decomposer populations (Berg *et al.*, 1987). The rate of decomposition is controlled by C/N and lignin/N ratios (Taylor *et al.*, 1989). The critical C/N ratio varies with climate and organic matter composition, but N immobilization has been reported in plant residue where the C/N ratio was above 25-30 (Blair, 1988). Plant residue components with a high C/N ratio and/or low initial N content showed slow release or high N immobilization (Rutigliano *et al.*, 1998). An increase in soil temperature (Domisch *et al.*, 2006) and moisture (Donnelly *et al.*, 1990) generally results in greater rates of microbial activity, and thus increased rates of mass loss from plant residue.

The objective of this research is to determine decomposition rate and patterns of plant residue of cool-season turfgrass clippings and grass-clover material returned to the sward and its influence on the sward. The differences in productivity between the plots with mowed grass remaining at its growing place and those with grass yield being removed by different nutrition regimes of the sward were discussed in this paper.

## Material and methods

The experiment was conducted at the Estonian University of Life Sciences in Tartu and was arranged as a randomized complete block with four replicates. The site had been seeded in 2003 with a turfgrass mixture (*Festuca rubra* 50% and *Poa pratensis* 50%) and with grass-clover mixture (*Phleum pratense* 34%, *Lolium perenne* 38% and *Trifolium repens* 28%). Experimental treatments for turfgrass sward were N<sub>0</sub>P<sub>0</sub>K<sub>0</sub>, N<sub>80</sub>P<sub>11</sub>K<sub>48</sub>, N<sub>160</sub>P<sub>22</sub>K<sub>96</sub> and N<sub>400</sub>P<sub>56</sub>K<sub>240</sub> and for grass-clover sward N<sub>0</sub>P<sub>0</sub>K<sub>0</sub> and N<sub>80</sub>P<sub>26</sub>K<sub>50</sub>. The turfgrass sward was cut 15-20 times and grass-clover sward 3-5 times at a height of 5 cm during the growing season. The clippings of turfgrass and grass-clover cut grass were either removed or returned to the plots.

Litterbags were used in 2006 to study the rate of organic matter weight loss during decomposition of turfgrass sward (15 May-10 July) and of grass-clover sward (30 May-25 July). The turfgrass clippings and grass-clover cut grass were harvested from the field plots and placed into seven litterbags (20 g fresh plant material per bag) and placed into the thatch layer of each plot. The bags were retrieved from the field after weeks 2, 3, 4, 5, 6, 7 and 8 to measure the changes in plant material weight. The plant residue in each bag was oven dried at 105°C for eight hours, then weighed to calculate the weight loss. Plant residue loss at each sampling was expressed as a percentage of the initial biomass.

The data were statistically analyzed by main effects and factorial ANOVA to test the effects of year, sward management treatment and fertilizers application on the total aboveground living plant biomass.

## Results and discussions

The analysis of variance showed that cut and returned grass decomposition rate was high ( $p < 0.00001$ ) during the first two weeks of decomposition especially in turfgrass sward. The speed of decomposition slowed after the third week and variances of decomposition rates between subsequent weeks were not significant. The weight loss after two weeks of turfgrass sward (43.9%) differed significantly ( $p < 0.05$ ) from that of grass-clover (20.8%) (Figure 1). Weight losses had, by the end of week eight increased up to 61.9% for turfgrass and to 48.7% for grass-clover. High variability of weight loss in grass-clover material probably depended on plant material heterogeneity in litter bags that is size and species of residues. The most important factors influencing the early phase of decomposition were the water-soluble nutrient content in the grass, followed by the lignin content, which is resistant to decay (McClaugherty and Berg, 1987). Our results indicated that compounds that decay easily decomposed in two weeks, whereas the relevant loss of weight in the following weeks is due to the lignin content. The different decomposition rates could therefore be related to the initial C/N and lignin/N ratios in fresh grass.

The fertilization of the swards did not, in this research trial, have a significant effect ( $p > 0.05$ ) on the decomposition of the different sward grasses which is in contrast to some other studies showing that the addition of mineral nutrients accelerate the decomposition of nutrient-limited substrates (Newell *et al.*, 1996). Nutrient uptake by plants, therefore, could conceivably reduce activities of decomposers. Moorhead *et al.* (1997) argued that growing plants can have a significantly negative effect on plant residue decay, possibly by reducing the availability of nitrogen for microbial immobilization to support decomposition.

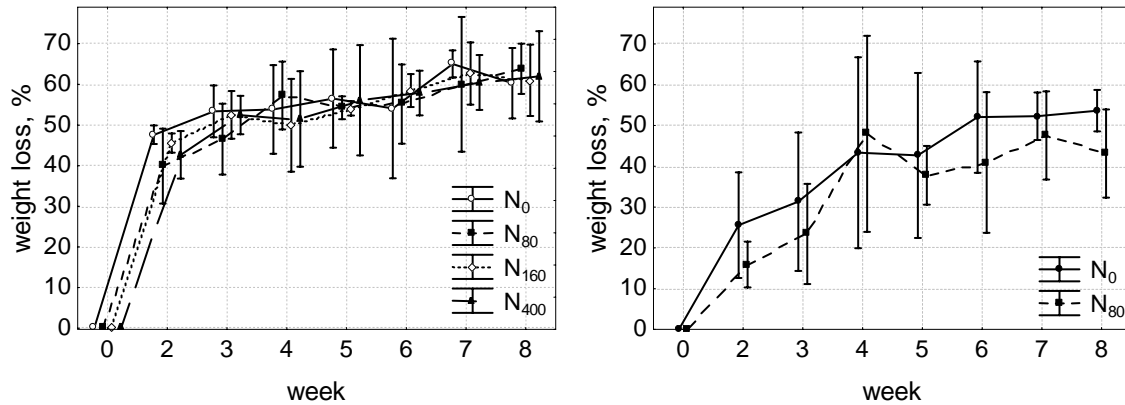

Figure 1. Plant residue loss (as percentage of the initial dry weight) in turfgrass and grass-clover swards (mean±SE p<0.05).

The influence of returned grass on the productivity of turfgrass and grass-clover swards was variable. The productivity of turfgrass sward in the first year after seeding (2004) was not significantly affected but in the following year productivity of plots treated with clippings produced on average 24.7 g m<sup>-2</sup> more than those plots that did not receive clippings, which is an approximate 15% increase (p<0.05). An excessively dry summer in the third year (2006) negated the benefits gained through the clipping treatment in the spring (Table 1).

Table 1. Dry matter yield (g m<sup>-2</sup>) of turfgrass and grass-clover swards with and without clipping addition by testing years and N fertilization rates. Different letters within each column indicate significant difference of the mean values at p<0.05.

	2004		2005		2006	
Fertilization rate	Without clipping	With clipping	Without clipping	With clipping	Without clipping	With clipping
Turfgrass						
N <sub>0</sub>	11.2a	8.7a	8.7a	8.6a	8.6a	8.5a
N <sub>80</sub>	15.1ab	16.5b	15.7b	18.0b	17.6b	17.3b
N <sub>160</sub>	20.6b	20.8b	19.5b	23.2c	22.0c	23.4c
N <sub>400</sub>	34.6c	33.5c	40.2c	48.8d	29.8d	27.5d
Grass-clover						
N <sub>0</sub>	14.4a	18.7a	13.2a	20.4a	12.4a	15.2a
N <sub>80</sub>	17.5b	22.5b	18.3b	22.1a	13.5a	16.2a

The effect of returning the clippings to grass-clover productivity was significant (p<0.05) throughout all three years, increasing the yield by 18-35% and performing as N addition equivalent of 110-200 kg N ha<sup>-1</sup>.

## Conclusions

The trial data indicates that slowly decayed grass-clover plant material influenced productivity more than turfgrass clippings. The results of this study do however vary with the findings of other studies. Whereas the data concurs that the speed of decomposition of plant material is defined by the quality of material and caused primarily by the content of water-soluble substances in decomposable material it is in conflict in the inference that the speed of decomposition is not affected by the rate of fertilization. We therefore suggest that due to these variances further research into the impact of decomposing material to sward productivity is required.

## Acknowledgements

The study was supported by Estonian Science Foundation grant No. 5751.

## References

- Berg B., Staaf H. and Wessen B. (1987) Decomposition and nutrient release in needle litter from nitrogen-fertilized Scots pine (*Pinus sylvestris*) stands. *Scandinavian Journal Forest Research*, 2, 399-415.
- Blair J.M. (1988) Nitrogen, sulfur and phosphorus dynamics in decomposing deciduous leaf litter in the southern Appalachians. *Soil Biology and Biochemistry*, 20, 693-701.
- Busey P. and Parker J.H. (1992) Energy conservation and efficient turfgrass maintenance. (Eds. Waddington, *et al.*). Turfgrass. Agronomy Monograph 32. ASA, CSSA, SSSA, Madison, WI., pp. 473-500.
- Domisch T., Finer L., Laine J. and Laiho R. (2006) Decomposition and nitrogen dynamics of litter in peat soils from two climatic regions under different temperature regimes. *European Journal of Soil Biology*, 42, 74-81.
- Donnelly P.K., Entry J.A., Crawford D.L. and Cromack Jr. K. (1990) Cellulase and lignin degradation in forest soils: response to moisture, temperature and activity. *Microbial Ecology*, 20, 289-295.
- Mary B., Recous S., Darwis D. and Robin D. (1996) Interactions between decomposition of plant residues and nitrogen cycling in soil. *Plant and Soil*, 181, 71-82.
- McClaugherty C. and Berg B. (1987) Cellulose, lignin and nitrogen concentrations as rate regulating factors in late stages of forest litter decomposition. *Pedobiologia*, 30 (2), 101-112.
- Moorhead D.L., Westerfield M.M. and Zak J.C. (1998) Plants retard litter decay in nutrient-limited soil: a case of exploitative competition? *Oecologia*, 113, 530-536.
- Newell S.Y., Arsuffi T.L. and Palm L.A. (1996) Misting and nitrogen fertilization of shoots of a saltmarsh grass: effects upon fungal decay of leaf blades. *Oecologia*, 108, 495-502.
- Rutigliano F.A., Alfani A., Bellini L. and Vizo De Santo A. (1998) Nutrient dynamics in decaying leaves of *Fagus sylvatica* L. and needles of *Abies alba* Mill. *Biology Fertility of Soils*, 27, 119-126.
- Taylor B.R., Parkinson D. and Parsons W.F.J. (1989) Nitrogen and lignin content as predictors of litter decay rates: a microcosm test. *Ecology*, 70, 97-104.

# **Nitrogen balance and nitrate residues in pastures grazed by dairy cows and fertilised with mineral fertiliser, pig slurry or cattle compost**

DufRASNE I., Meura S., Cabaraux J.F., Istasse L. and Hornick J.L.

*Nutrition Unit, University of Liège, Boulevard de Colonster, 4000 Liège, Belgium*

## **Abstract**

A code of good practices was established by each European member state according to the nitrate directive. In Belgium, the nitrogen (N) inputs from slurry or compost are limited to 230 kg N/ha in pastures. Larger amounts can be applied when a program of additional measurements, including soil nitrates analysis, is followed by the farmer. This trial aims to measure nitrogen balance and soil nitrates in pastures fertilised with mineral nitrogen fertiliser (min N), pig slurry (S) or cattle compost (C). The pastures were grazed by dairy cows and the fertilisation allowed similar efficient N levels.

N inputs by fertilisation were different at 169, 170 and 102 kg N/ha in C, S and min N plots respectively. The use of pig slurry and cattle compost as compared with mineral N fertiliser increased N balance and reduced apparent N efficiency. The nitrogen, potassium and phosphorus nutrition indexes, the number of grazing days and the milk yields per ha were not different. The soil nitrate contents were not increased by use of slurry or compost. The overall low nitrate contents suggested a low nitrate leaching with the three types of fertilisation.

Keywords : fertilisation, dairy cows, nitrogen, slurry, compost

## **Introduction**

A code of good practice was established by each European member state according to the Nitrate Directive. In Belgium, the organic nitrogen (orgN) inputs from direct excretal rejections and manure spreading are limited to 230 kg orgN ha<sup>-1</sup> on grasslands or to 115 kg orgN ha<sup>-1</sup> on arable lands. A derogation allows application of larger quantities when the farmer commits himself in a fertilizer management programme called 'Quality approach' in which the maximum amount is 250 kg orgN ha<sup>-1</sup> on grasslands and 130 kg orgN ha<sup>-1</sup> on arable lands. To benefit from the derogation, the farmer has to prove that field management reaches a satisfactory level. Soil nitrate residues are measured yearly before winter in 5 fields per farm randomly chosen and compared with reference values but there is a lack of data on mineral balance and nitrate residues in grazed pastures fertilized with orgN.

This trial aims to measure nitrogen (N) balance, nitrogen nutrition index (NNI), potassium nutrition index (KNI), phosphorus index (PNI) and soil nitrates contents in pastures fertilised with mineral nitrogen fertiliser (min N), pig slurry (S) or cattle compost (C). The pastures were grazed by dairy cows and the fertilisation was calculated to bring an allowed amount of orgN from fertilisation by slurry or compost. A pasture, grazed and fertilised with mineral fertiliser, was used as control.

## **Materials and methods**

The experiment was carried out on permanent pastures located in the area of Liège (Belgium) at 150 meters above sea level. The soil was mainly constituted by loam (0.002-0.05 mm: 71.6% ; 0.05-2 mm: 11.1%) and by clay (0-0.002 mm ;17.3%). The mean annual rainfall was 848 mm and the mean average temperature was 8.9°C. During 5 consecutive years, 40-45

dairy cows grazed 6 paddocks in a rotational system. Three of these paddocks were used in this trial. The first paddock was fertilized with cattle compost, the second with pig slurry and the third with mineral nitrogen fertiliser. In this paddock, the first mineral fertilisation in Spring provided also P and K. Cattle compost was produced from cattle manure unloaded through the beaters of a spreader. The grass chemical composition was determined in each paddock before each entry. Botanical composition was determined each year. Grass heights were measured before and after grazing. Grass samples were taken and grass yields were measured before each grazing. Botanical composition was estimated each year by a technique adapted from the method of frequencies. The cows were milked twice per day and milk productions were recorded at each milking. Milk was sampled at each milking in order to measure milk urea. The animals were weighed before and after each paddock grazing. NNI was calculated as the ratio of the actual N concentration to the sward N concentration it would have to be at a similar biomass in order to sustain a non limiting growth and a biomass accumulation (Lemaire and Gastal, 1997). KNI and PNI were calculated from grass yields, grass N, K and P contents according Th  lier-Huch   *et al.* (1999). Nitrogen surplus was calculated by the difference between N inputs and N outputs. N inputs were composed by the legume fixation (Farrugia *et al.*, 1997), atmospheric N ( $35 \text{ kg ha}^{-1}$ ) and N from fertilisation. N efficiency was estimated at 30% in C (back-effects included), at 50% in S and at 100% in min N. N in milk, concentrate and live weight gains represented N outputs. Seven soil cores per ha were randomly taken up to 60 cm depth (0-30 and 30-60 cm) each year in November and in March in order to determine the soil nitrate content (N-NO<sub>3</sub><sup>-</sup>). Nitrate was analysed by hydrazin reduction on an automated analyser (Skalar). Linear models including years and treatments effects were used for statistical analyses

## Results and discussion

The inputs of N, P<sub>2</sub>O<sub>5</sub> and K<sub>2</sub>O<sub>3</sub> by fertilisation respectively at 169, 107 and 135 kg ha<sup>-1</sup> in C, 170, 76, 93 kg ha<sup>-1</sup> in S and 102, 31 et 45 kg ha<sup>-1</sup> in min N were different. N inputs expressed as efficient N were 51 kg in C and 85 kg in S. The grass yield was significantly higher in S than in C ( $p < 0.05$ ), the grass yield in min N being intermediate (Table 1). There were no differences in grazing heights, crude protein content, NNI owing to similar grazing management in the 3 plots. PNI and KNI did not differ. The recommended grass NNI, PNI and KNI should range between 80 to 100%; lower values indicating a limitation of grass yields by mineral deficit while higher values being considered as a mineral waste (Th  lier-Huch   *et al.*, 1999). So, the present index nutrition values can be considered as adequate with the three fertilisation types. The higher amount in P<sub>2</sub>O<sub>5</sub> and K<sub>2</sub>O<sub>3</sub> from fertilisation in C and S did not increase PNI and KNI. The grazing duration expressed as herd grazing days and the milk yields were not significantly different. The legumes proportion was significantly higher in C plot as compared to min N plot.

The N surplus was significantly lower in min N than in S and C ( $P < 0.05$ : Figure 1). The apparent N efficiency calculated as the ratio of N output on N input, was significantly lower in S and C than in min N (19.8 and 19.6 vs 26.2%;  $P < 0.05$ ). Nitrate residues in soil were generally lower than  $35 \text{ kg N-NO}_3^- \text{ ha}^{-1}$  (Figure 2). They were significantly higher in the 0-30 cm depth than in the 30-60 cm depth ( $29.7 \text{ vs } 12.7 \text{ kg N-NO}_3^- \text{ ha}^{-1}$  ( $P < 0.001$ )). There were not significant differences between fertilisation systems (19.8, 19.7 and  $29.0 \text{ kg N-NO}_3^-$  in C, S N-NO<sub>3</sub>). These values were much lower than those reported by De Vlieghe *et al.* (2004). These authors reported an average of  $76 \text{ kg N-NO}_3^-$  in the soil (0-90 cm) of pastures with similar slurry amounts as those used in this trial. According Nevens and Rehuel (2003)  $60 \text{ kg N-NO}_3^-$  were left in sandy loam soil from grazed pastures fertilised with  $100 \text{ kg mineral N ha}^{-1}$ .



Table 1. Grass characteristics, milk yield and milk urea concentration in pastures fertilised with compost, slurry and mineral nitrogen.

	<i>Compost</i>	<i>Slurry</i>	<i>Mineral Nitrogen</i>	<i>SEM</i>
<i>Grass (kg DMha<sup>-1</sup>)</i>	10 016a	11 052b	10736ab	218
<i>Height in (cm)</i>	13.3a	13.3a	12.9a	0.3
<i>Height out (cm)</i>	5.1a	4.9a	5.1a	0.15
<i>Graminae (%)</i>	58.0a	62.5a	60.5a	2.8
<i>Legumes (%)</i>	14.2a	9.9ab	7.5b	1.6
<i>Others (%)</i>	7.84a	4.62a	4.52a	1.42
<i>CP content (g kg<sup>-1</sup> DM)</i>	206a	215a	212a	0.25
<i>Herd grazing days(d ha<sup>-1</sup>)</i>	11.6a	11.0a	11.0a	0.2
<i>Milk yields (kg ha<sup>-1</sup>)</i>	7718a	7435a	7144a	145
<i>Milk urea (mg l<sup>-1</sup>)</i>	289a	321a	333a	17
<i>NNI (%)</i>	78.5a	83.0a	82.9a	3.7
<i>PNI (%)</i>	103.8a	106.2a	101.4a	2.9
<i>KNI (%)</i>	97.3a	95.7a	95.9a	1.1
<i>App N efficiency (%)<sup>1</sup></i>	19.8a	19.6a	26.2b	2.0

<sup>1</sup>apparent N efficiency : ratio of N output on N input

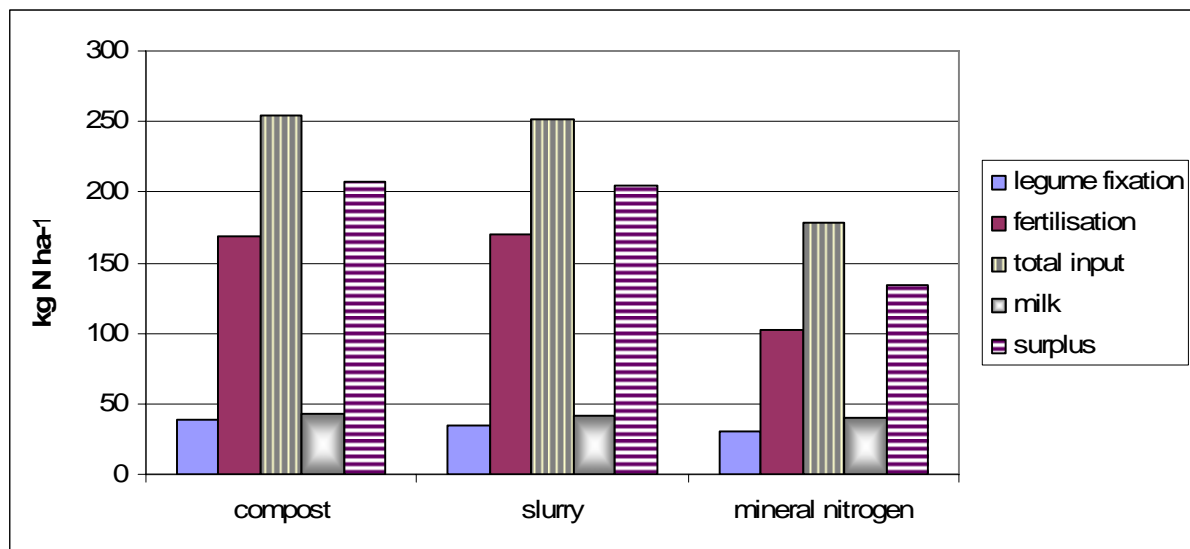

Figure 1. Nitrogen balance in pastures fertilised with compost, slurry or mineral nitrogen.

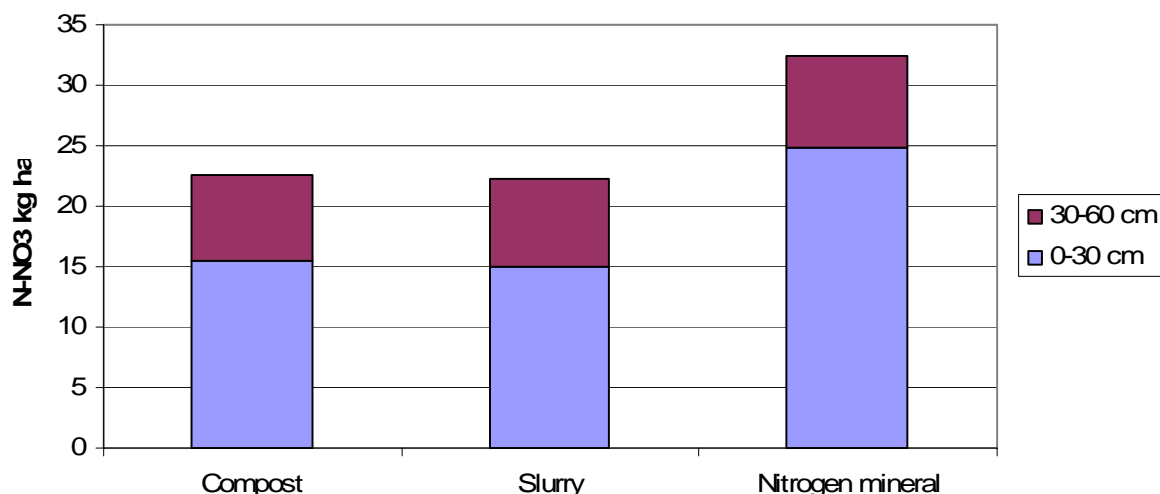

Figure 2. Soil nitrate content in pastures fertilised with compost, slurry or mineral nitrogen.

## Conclusion

The use of pig slurry and cattle compost as compared with mineral N fertiliser did not influence sward characteristics, except legumes proportion. The grass mineral nutrition indexes were not modified by the treatments. Milk yield increased N balance and reduced apparent N efficiency. The grazing days and the milk yields per ha were not different. The nitrate contents in soil were not increased by use of slurry or compost. The low nitrate contents suggested a low nitrate leaching with the three types of fertilisation. These results prove that when slurry or compost is used with good practice, they do not decrease animal production and they do not increase nitrate leaching risks.

## Acknowledgement

This research was supported by Direction Générale de l'Agriculture - Région Wallonne, Belgium.

## References

- De Vliegher A., Bries J. and Carlier L. (2004) Yield and residual nitrate nitrogen in soil of grazed grassland with different slurry applications. In : *Proc. of the the 20<sup>th</sup> General Meeting of the European Grassland federation*, , Switzerland, pp711-713.
- Lemaire G. and Gastal F. (1997) N uptake and distribution in plant canopies. In : Lemaire G. (ed.) *Diagnosis of the nitrogen status in crops*, 3-43, Heidelberg, Germany : Springer-Verlag
- Nevens F. and Rehuel D. (2003) effects of cutting or grazing swards on herbage yield, nitrogen uptake and residual soil nitrate at different levels of N fertilization. *Grass and Forage Science*, 58, 431-449.
- Thélier –Huché L., Farrugia A. and Castillon P. (1999) Publication de l'Institut de l'Elevage: l'analyse d'herbe, 31pp.

# Nitrate content of soil water under forage crops fertilised with dairy slurry in nitrate vulnerable zone

Mantovi P.<sup>1</sup>, Ligabue M.<sup>2</sup> and Tabaglio V.<sup>3</sup>

<sup>1</sup> CRPA Foundation Studies and Researches, Corso Garibaldi, 42- Reggio Emilia 42100, Italy

<sup>2</sup> Research Centre on Animal Production (CRPA), Corso Garibaldi, 42- Reggio Emilia 42100, Italy

<sup>3</sup> Institute of Agronomy and Field Crops, Università Cattolica del Sacro Cuore, Via Emilia Parmense, 84 - Piacenza 29100, Italy

## Abstract

Three contiguous plots established on highly permeable soil in the Po valley (Italy), and equipped with tensiometers and ceramic cup samplers, have been cropped respectively with lucerne (*Medicago sativa*), tall fescue (*Festuca arundinacea*), and their mixture. Dairy slurry was applied three times during the second year (at the end of the winter and after the 1<sup>st</sup> and 4<sup>th</sup> cut), with total amounts of 272 kg N ha<sup>-1</sup> for tall fescue and 136 kg N ha<sup>-1</sup> (half rate) for the mixture. Lucerne was not fertilised with nitrogen.

Total yields for the 5 cuts were 17.8 t DM ha<sup>-1</sup> for lucerne (average protein content 18.2% DM), 10.9 for tall fescue (protein 12.6% DM) and 19.2 for the mixture (protein 17.0% DM). Soil water nitrate content was steadily low under each of the three forage crops, with average values ranging from 5 (tall fescue plot) to 10 (lucerne plot) mg NO<sub>3</sub>-N l<sup>-1</sup>, without significant negative impact on groundwater. Activities are currently being carried out to verify the effect of repeated application rates higher than the 170 kg N ha<sup>-1</sup> year<sup>-1</sup> limit fixed for NVZ in Nitrate Directive 91/676.

Keywords: ceramic cups, dairy slurry, lucerne, tall fescue, Nitrate Vulnerable Zones (NVZ)

## Introduction

The Nitrate Directive 91/676 fixes the maximum limit for manure application at 170 kg N/ha/year in Nitrate Vulnerable Zones (NVZ). The use of mineral fertilisers is not subject to the same limit.

It seems reasonable to argue that manure can be applied in excess of the value of 170 kg N/ha/year in dairy farms with extensive areas of grassland, without a significant increase in nitrate leaching. Data from different trials confirmed that on normal productive cut grassland, also after incorporation of long-term effects, total nitrogen amounts of cattle slurry up to 400 kg/ha/year have very little effect on residual mineral nitrogen in autumn, if not accompanied by high mineral fertiliser doses (Ten Berge *et al.*, 2002).

The main purpose of this study is to evaluate nitrate leaching from leys on highly permeable soil in NVZ in the Po valley (Italy).

## Materials and methods

In the spring of 2005 three different swards of lucerne (*Medicago sativa*), tall fescue (*Festuca arundinacea*) and a mixture of the two were established on three contiguous 50 x 30 m plots on a loamy skeletal, mixed, mesic Udic Haplustepts which had been fertilised with farmyard manure at the rate of 175 kg N ha<sup>-1</sup> in October 2004. Each plot was equipped with 6

tensiometers to measure soil potential at depths of up to 180 cm and 9 ceramic cup samplers to collect soil water in depths of up to 500 cm.

No fertilisers have been applied nor forage crops harvested over 2005. The three plots were managed as specified in Table 1 over the following year.

Table 1. Management of the three plots

Data	1. Activities	Application rate
20 March 2006	Dairy slurry application	90 kg N ha <sup>-1</sup> *
12 May 2006	1 <sup>st</sup> cut	
23 May 2006	Dairy slurry application	106 kg N ha <sup>-1</sup> *
15 June 2006	Irrigation	80 mm
22 June 2006	2 <sup>nd</sup> cut	
08 July 2006	Irrigation	80 mm
17 July 2006	3 <sup>rd</sup> cut	
28 August 2006	4 <sup>th</sup> cut	
06 September 2006	Dairy slurry application	76 kg N ha <sup>-1</sup> *
13 October 2006	5 <sup>th</sup> cut	

\*: application rate for tall fescue, half-rate for tall fescue+lucerne, no slurry for lucerne

Dairy slurry (7% DM, 2.5 g kg TKN) was applied three times, with total amounts of 272 kg N ha<sup>-1</sup> for tall fescue and 136 kg N ha<sup>-1</sup> (half rate) for the mixture. Lucerne received mineral phosphorus and potassium to compensate for the missing slurry input but was not fertilised with nitrogen. The plots were irrigated twice by a spray boom at 30 mm/hour. The three swards were harvested five times over 2006; herbage production was measured at each cut in areas the size of 2.5 x 5 m, with three replicates for each sward. Dry matter production and forage quality were determined (protein, fibre and ash content, NDF, ADF, ADL).

Soil potential data were registered every 12 hours by electronic loggers connected with tensiometers. Soil water was sampled from ceramic cups to determine NO<sub>3</sub>-N and NH<sub>4</sub>-N concentrations every 3 weeks; sampling nearer the surface was limited by low soil potential values during the dry season. Soil samples were taken from each plot about every 3 months, the layer sampling (20 cm) reached a depth of 60 cm, with three replicates. Each sample was tested for NO<sub>3</sub>-N concentration.

Results up to October 2006 are included in this paper.

## Results and discussion

Average temperatures and rainfall during the January-October 2006 period are presented in Table 2. The matric potential of the soil remained near zero (value that corresponds to the presence of free water) up to April. From April onwards there was progressive drying of horizons interrupted sporadically by rainfall and irrigation, particularly for the 1 metre top layer.

Table 2. Monthly average air temperature and rainfall in 2006

	Jan	Feb	Mar	Apr	May	Jun	Jul	Aug	Sep	Oct
Average temperature (°C)	0.8	3.5	7.5	12.9	18.0	22.7	26.6	21.7	20.5	15.2
Rainfall (mm)	43.6	50.6	28.4	31.0	19.4	9.6	9.4	92.0	175.0	22.0

Figure 1 illustrates forage yields obtained in 2006 while Table 3 shows the average forage quality characteristics.

Figure 1. Dry matter yield for the five cuts

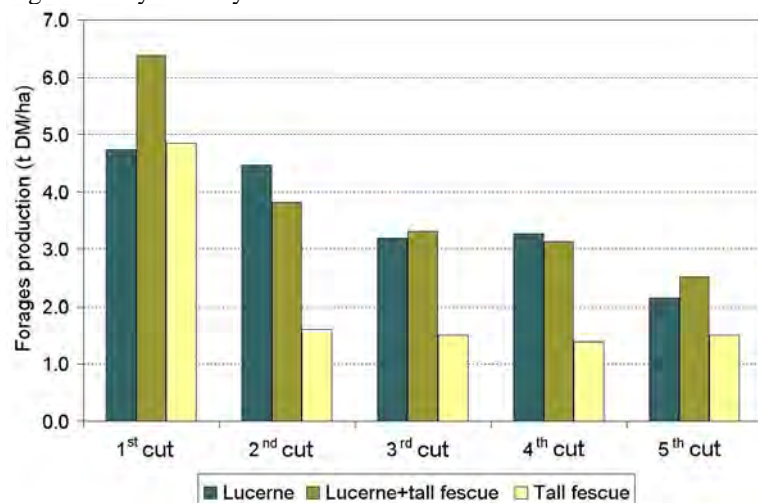

Table 3. Total dry matter yield and chemical characteristics of the forages (5 cuts average)

	Lucerne	Lucerne+ tall fescue	Tall fescue
Annual yield (t DM ha <sup>-1</sup> )	17.8	19.2	10.9
Mean protein content (% DM)	18.2	17.0	12.6
Total N uptake (kg ha <sup>-1</sup> )	518	520	218
Fibre content (% DM)	31.5	29.2	24.7
Ash content (% DM)	10.4	10.4	10.2
NDF (% DM)	49.1	50.3	58.5
ADF (% DM)	37.0	34.3	29.1
ADL (% DM)	8.0	6.7	3.6

Production was very good for lucerne and the mixture, both in quantity and quality, assisted by the rainfall in August and September and the mild temperatures maintained up to October. Tall fescue in the mixture was overwhelmed by lucerne after the first cut. Pure tall fescue production was clearly lower. This sward was not well established at the start of 2006 and it suffered from the heat and dryness of the first part of the summer. Probably it also suffered from lack of nitrogen as seems to be confirmed by the following data.

In Figure 2 changes in the nitrate nitrogen concentrations in soil water are illustrated for each plot according to the length of time (X-axis, 2 years) and the depth of the soil (Y-axis, 500 cm), through concentration isolines obtained from data interpolation.

Soil water nitrate content was constantly low under each of the three forage crops, with average values for 2006 ranging from 5 (tall fescue) to 10 (lucerne) mg NO<sub>3</sub>-N/l, without significant negative impact on groundwater.

During the monitoring period, the NH<sub>4</sub>-N concentrations in the soil water were always distinctly lower than NO<sub>3</sub>-N values (with average values <0.2 mg l<sup>-1</sup> NH<sub>4</sub>-N), as already verified in other trials (Mantovi *et al.*, 2006).

The concentrations of nitrates in the soil were constantly low (average value of 6.5 mg NO<sub>3</sub>-N kg<sup>-1</sup> in 2006) with no marked differences among the three swards. Over the summer of 2006 the lowest concentrations were found in the tall fescue plot even though slurry had been applied and forage production was poor (but in any case with quite good apparent recovery of nitrogen). In the same plot there was no accumulation of residual mineral soil nitrogen during the autumn (about 50 kg ha<sup>-1</sup> of soil NO<sub>3</sub>-N in the 0-60 cm soil layer at the end of October).

Figure 2. Nitrate nitrogen concentration in soil water (mg NO<sub>3</sub>-N/l), for each plot

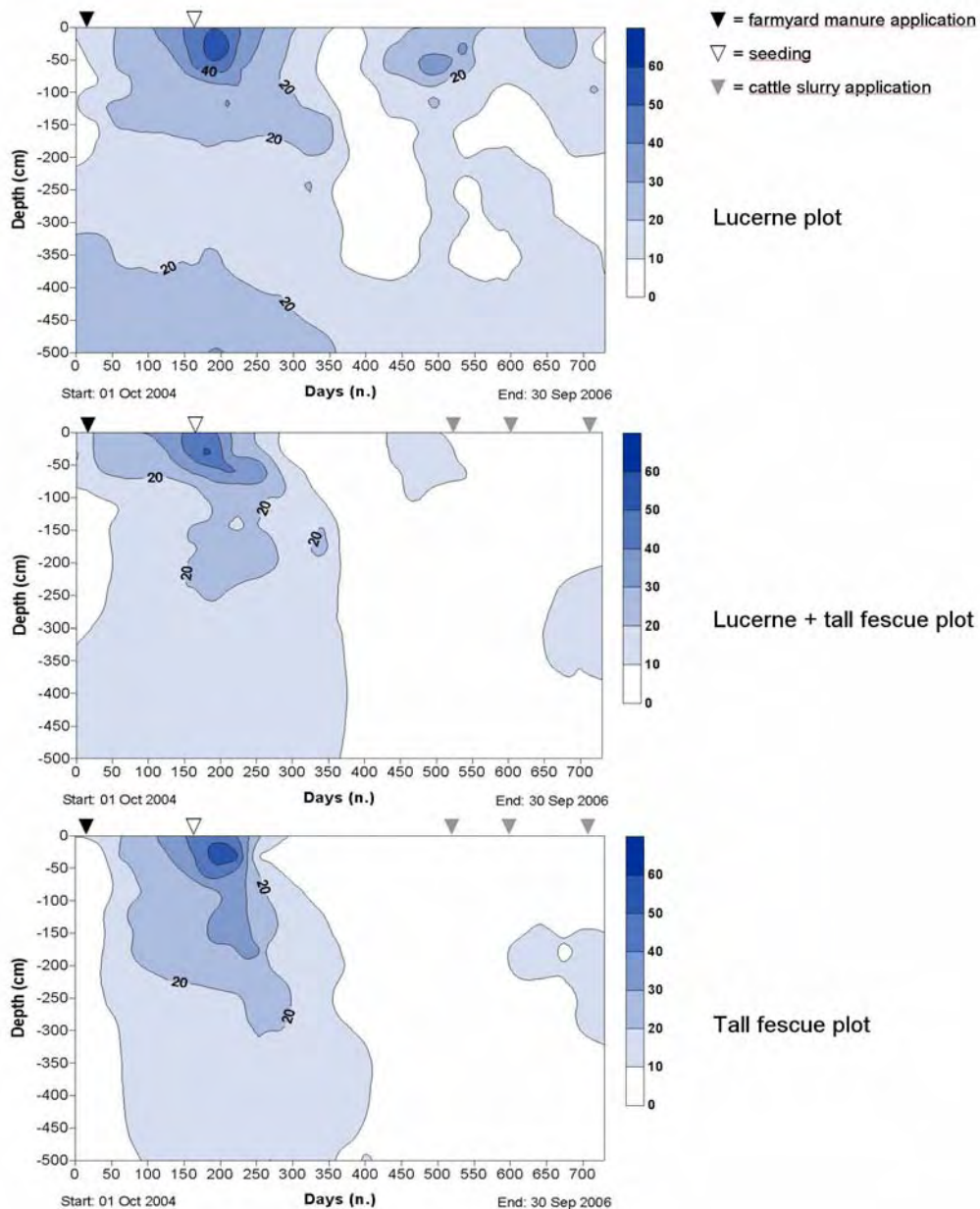

## Conclusion

The results obtained confirm that forage crops, in particular some grasses fertilised with nitrogen from slurry applied at rates of more than 170 kg N ha<sup>-1</sup>/year, are able to deplete nitrates in the soil and in the soil water in vulnerable soils. It is thus possible to qualify these crops as useful to protect groundwater from the infiltration of these pollutants.

Activities are now being conducted to test the effect of repeated application rates significantly higher than the 170 kg N ha<sup>-1</sup>/year limit fixed for NVZ in Nitrate Directive 91/676.

## References

- Mantovi P., Fumagalli L., Beretta G.P. and Guermandi M. (2006). Nitrate leaching through the unsaturated zone following pig slurry applications. *Journal of Hydrology*, 316, 195-212.
- Ten Berge H.F.M., Van Der Meer H.G., Carlier L., Baan Hofman T. and Neeteson J.J. (2002). Limits to nitrogen use on grassland. *Environmental Pollution*, 118(2), 225-238.

# Link between the organic fraction of grazed grasslands nitrogen fertilisation and the nitrate leaching risk

Hennart S.<sup>1</sup>, Froidmont E.<sup>2</sup>, Destain J.P.<sup>3</sup>, Decuyenaere V.<sup>1</sup> and Stilmant D.<sup>1</sup>

<sup>1</sup>Farming Systems Section, CRA-W, rue de Serpont 100, B-6800 Libramont, Belgium

<sup>2</sup>Animal Productions and Nutrition Department, CRA-W, rue du Liroux 8, B-5030 Gembloux, Belgium

<sup>3</sup>Plant Productions Department, CRA-W, rue du Bordia 4, B-5030 Gembloux, Belgium

## Abstract

In the context of the Nitrate Directive there is a clear limitation on organic nitrogen fertilisation that, on grassland, in Walloon area, couldn't go over 230 kg N ha<sup>-1</sup> in the new proposal. Now the total amount of N fertilisation on grassland is limited to 350 kg N ha<sup>-1</sup>. Is there a negative environmental impact to supply a higher proportion of this total, potential N fertilisation, under an organic form?

To answer this question, a gradient of organic fertilisation, ranged from 110 kg N ha<sup>-1</sup> (dairy cows restitutions under grazing) to 350 kg N ha<sup>-1</sup> (restitutions and slurry spreading), was applied on mix mowed and grazed grasslands. Two repetitions were performed for each of the four modalities (110, 140, 240 and 350 kg organic N ha<sup>-1</sup>) compared over two seasons. Nitrate leaching risk was quantified at the end of each grazing season through the analysis of three soil samples including, each, 30 cores from the 0-30 cm profile. N inputs and outputs were quantified, at the field scale, all across the grazing season.

This trial is running since the beginning of 2004. Over the two first years, the mean nitrate concentration observed was of 35 kg N-NO<sub>3</sub><sup>-</sup> ha<sup>-1</sup> with a 16.6 kg N-NO<sub>3</sub><sup>-</sup> ha<sup>-1</sup> SD of the mean. No impact, nor of the year ( $F(1,15) = 1.2$ ;  $p = 0.312$ ) neither of the fertilisation scheme ( $F(3,15) = 0.7$ ;  $p = 0.597$ ), was observed while a significant correlation ( $R=0.616^{**}$ ;  $N=15$ ) was highlighted between this leaching risk indicator and the nitrogen balance measured at the field scale at the end of the grazing season.

Keywords: fertilisation scheme, mineral N, organic N, dairy cow, nitrate leaching risk

## Introduction

In the context of the Nitrate Directive, the new proposal of the Walloon Government, applied in 2007, limit the organic nitrogen fertilisation at 230 kg N ha<sup>-1</sup> on grassland, including pasture restitution. As for the other crops, the total nitrogen fertilisation can not exceed 350 kg N ha<sup>-1</sup>. Now, grassland can be exploit several times during the same season and valorise, export more nitrogen than other crops and this all around the growing season.

Due to these proprieties, the question of which proportion of the 350 kg ha<sup>-1</sup> of total nitrogen the grassland is able to valorise with no negative impact on the environment is explored.

## Material and methods

The experimental site was located in the Department of Animal Nutrition and Production in Gembloux. Height permanent grasslands were gathered in 2 blocks according to there age. The grasslands of the first block were older than 25 years (old grasslands) while the grasslands of the second block were implanted in 1999 (young grasslands). To obtain a gradient of organic fertilisation, four modalities, i.e. 110, 140, 240 and 350 kg N ha<sup>-1</sup> from

organic fertiliser, repeated on each block of grassland, were applied in 2004 and 2005. Restitutions of 110 kg N ha<sup>-1</sup> were achieved through the rotational grazing of 40 dairy cows on a global surface of 17.7 ha. During the rotation, the grazing time, on a paddock, was function of the season and of the paddock surface, ranged between 95 and 160 ares. The N restitution was calculated with the legal norm of dairy cattle restitution in Wallonia, to say 90 kg N cow<sup>-1</sup> year<sup>-1</sup>, balanced by the milking time (estimated to be 3 hours day<sup>-1</sup>) (Hupin, 2006). The remaining organic fertilisation comes from liquid manure, mainly cow slurry and a little pig slurry. Liquid manure was analysed after each spreading in order to adjust the following applications and to respect our fertilisation schemes. When indicated, mineral nitrogen (27-0-0) was used to reach the total of 350 kg N ha<sup>-1</sup>.

The herd is compounded by 35 to 45 dairy cows with an average of 6000 kg of milk by year. They pastured from the 15<sup>th</sup> of April to the 16<sup>th</sup> of October in 2004 and from the 28<sup>th</sup> of April to the 28<sup>th</sup> of October in 2005. Silage exportation, in quantity and quality, the grass availability (grass height) and the quantity of complementary feeding were recorded daily on pasture calendar.

Nitrogen balance was estimated for each paddock. The inputs were the organic and mineral fertilisers, the cow complementation, the mineralization and the symbiotic nitrogen fixation by white clover. Nitrogen fixation is linked to the percent of clover measured, in 2005, within each grassland. The mineralization was estimated to 80 kg N ha<sup>-1</sup> year<sup>-1</sup> for each grassland (same soil and climate conditions).

The outputs were the milk production, the restitution during the milking time, the exportations with the silage. The milk production of each paddock is obtained in crossing the pasture calendar and the daily milk production. The N balance is calculated, on the one hand, for the complete season and, on the other hand, for the end of the grazing season, after the 1<sup>st</sup> of September, when nitrogen load has a higher impact on leaching risk.

Nitrate leaching risk was quantified at the end of each grazing season. To do so, three soil samples, each compounded of 30 cores from the 0-30 cm profile, were analysed for every paddock.

## Results and discussion

Nitrogen spreading was, on average, of 357 kg N ha<sup>-1</sup>, ranged between 286 and 442 kg ha<sup>-1</sup> (Figure 1). The threshold of 350 kg ha<sup>-1</sup> was exceeded in the paddock 3 following an over-estimation of the paddock area as highlighted by a new measurement exercise performed in 2005. The grasslands 1 and 12, that need any mineral nitrogen don't receive enough liquid manure due to the lack of slurry stock during good spreading time or due to the lack of good spreading conditions at key periods. This underlines the lower flexibility of such a fertilisation scheme when the stocking capacity is not large enough.

Cattle restitutions at grazing were, in average, very close from the target of 110 kg N ha<sup>-1</sup> (109 kg ha<sup>-1</sup> in 2004 and 111 kg N ha<sup>-1</sup> in 2005). Nevertheless its standard deviation was lower in 2004, with 27 kg ha<sup>-1</sup>, then in 2005, with 6 kg ha<sup>-1</sup>.

N-NO<sub>3</sub><sup>-</sup> content in the soil was, in average, of 35.5 kg N ha<sup>-1</sup>: 30.9 in 2004 and 39.8 in 2005. The value observed in the paddock 4, in 2005, was of 81.3 kg N ha<sup>-1</sup>. This value is higher than the mean observed in 2005 plus 2 times the standard deviation of this population. So this value was not included in the analyse. The new average, calculated with 15 values, was 32.3 kg N ha<sup>-1</sup> while the standard deviation shifted from 16.6 to 9.3 kg N ha<sup>-1</sup>. Neither the year (F(1,15)=1.2; p=0.312) nor the fertilisation scheme (F(3,15)=0.7; p=0.597) had a significant impact on N-NO<sub>3</sub><sup>-</sup> content in the soil.



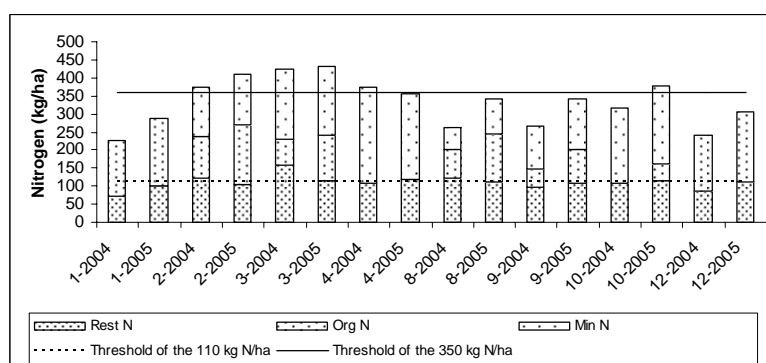

Figure 1: Organic, mineral and restitution nitrogen ( $\text{kg N ha}^{-1}$ ) for every paddock, during the years 2004 and 2005. The thresholds for cattle restitution at grazing ( $110 \text{ kg ha}^{-1}$ ) and for the amount of nitrogen to be spread ( $350 \text{ kg ha}^{-1}$ ) are indicated.

Table 1: Value of the N balance ( $\text{kg N ha}^{-1}$ ) and of the different input and output used for its calculation, for each paddock (paddock number-organic N target) in 2004 and 2005.  $\text{N-NO}_3^-$  contained in the soil at the end of the grazing season: average of 3 samples including, each, 30 soil cores ( $\text{kg N-NO}_3^- \text{ ha}^{-1}$ ).

Parcel	Age = Block	Importation ( $\text{kg N ha}^{-1}$ )				Exportation ( $\text{kg N ha}^{-1}$ )			N Balance ( $\text{kg N ha}^{-1}$ )	N Soil ( $\text{kg N-NO}_3^- \text{ ha}^{-1}$ )
		Organic N	Mineral N	Animal compl.	Clover fix.	Milk export	Cutting export	Outside parcel restit.		
<i>Year 2004</i>										
1-350	Old	155	0	34	44	32	90	10	180.4	18.3
2-240	Old	115	138	69	44	67	75	23	281.2	34.2
3-210	Old	69	194	93	14	81	75	24	270.6	31.2
4-110	Old	0	266	58	24	50	90	15	272.7	29.1
8-240	Young	79	64	66	65	63	75	17	198.4	34.8
9-210	Young	52	118	52	54	52	75	14	215.1	30.9
10-110	Young	0	209	60	6	52	90	16	197.6	40.9
12-350	Young	155	0	47	109	43	90	12	246.0	27.6
<i>Year 2005</i>										
1-350	Old	185	0	58	44	54	82	14	217.0	38.9
2-240	Old	164	142	60	44	61	75	18	335.6	44.5
3-210	Old	124	192	64	14	66	138	16	253.6	47.9
4-110	Old	0	238	73	24	70	75	17	253.9	81.3
8-240	Young	132	97	67	65	57	90	16	279.3	18.0
9-210	Young	94	140	66	54	59	90	16	270.7	18.4
10-110	Young	48	216	63	6	55	90	16	252.6	30.3
12-350	Young	195	0	66	109	55	90	16	289.1	39.2

No relation was highlighted between the soil  $\text{N-NO}_3^-$  content and the N balance calculated across all the grazing season ( $R=0.16$ ;  $N = 15$ ;  $p > 0.10$ ). (Table 1)

Based on these two first years of observation, the only significant correlation was established years between the soil  $\text{N-NO}_3^-$  content and the N balance calculated for the end of the grazing period ( $R= 0.616$ ;  $N = 15$ ;  $p < 0.01$ ). However, as illustrated on Figure 2, soil  $\text{N-NO}_3^-$  content decreases as N balance increase. This has to be reconsidered once taking into account the efficient fraction of the organic fertiliser.

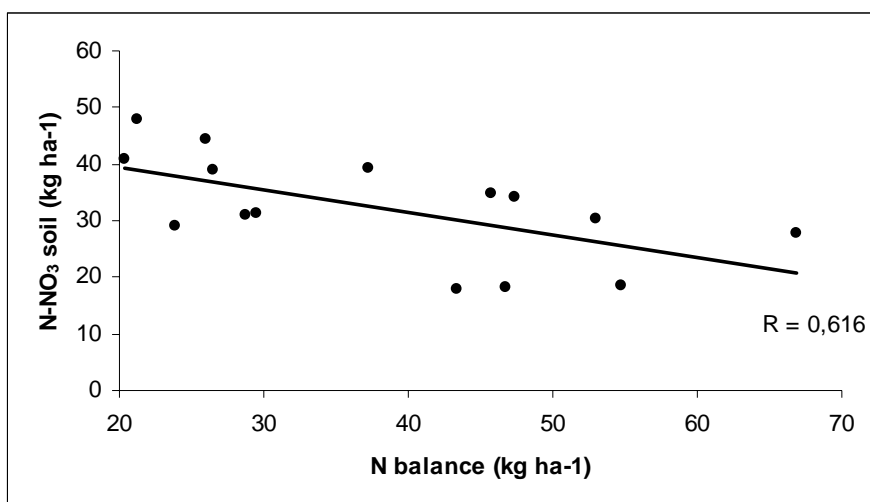

Figure 2: Relation between soil N-NO<sub>3</sub><sup>-</sup> content, in kg ha<sup>-1</sup>, and the nitrogen balance, in kg ha<sup>-1</sup>, calculated after the 1st of September.

## Conclusions

The first results of this study, that has to last for at least 5 years if we want to profit from the direct and the back effects from the organic fertiliser, highlight the difficulty to reach such high organic fertilisation schemes under grazing. Nevertheless, after two years, the total substitution of the mineral by organic nitrogen seems possible from an environmental point of view. However a important attention have to be paid to the evolution of grassland sward composition, in terms of plant species, and quality.

## Acknowledgements

This research was supported by the Ministry of the Walloon region, Rural Development Direction, grant n°2738/1.

## References

- Delaby L., (2000) Effet de la fertilisation minérale azotée des prairies sur la valeur alimentaire de l'herbe et les performances des vaches laitières au pasturage. *Fourrages*, 164, 421-436.
- Farrugia A. and Simon J.C. 1994. Déjections et fertilisation organique au pasturage. *Fourrages*, 139, 231-253.
- Hennart S., Stilmant D., Lambert R. and Vandenberghe Ch. (2004) Accuracy of the nitrate sampling scheme, proposed in Walloon area, for grazed grasslands. *In Proceedings of the 14th N workshop*, Maastricht, The Netherlands, 300-302
- Luxen P. (2000) l'azote en prairie et qualité des eaux, une organisation d'Agra-Ost et du Comité Nitrates, Bütchenbach, 18 février 2000, 33-44.
- Hupin F. (2006) Le programme de gestion durable de l'azote (PGDA) change. *In Les cahiers de l'agriculture*, 42.
- Stilmant D., Fabry L. and Parache. P. (2002) Nitrogen balance excess in livestock farming systems : link to grassland cover and identification of sustainable structures to promote. *In : Multi-function grasslands. Quality Forages, Animal Products and Landscapes*. J.-L. Durand, J.C. Emile, Ch. Hugue and G. Lemaire (eds.) Grassland Science in Europe, 7, 944-945.

# Leached ion concentrations depending on long-term meadow soil pH<sub>KCl</sub> and fertilisation

Butkutė R.

*Lithuanian Institute of Agriculture, Vėžaičiai Branch, Gargždų 29, LT-96216, Vėžaičiai, Klaipėda District, Lithuania*

## Abstract

The trial was carried out on 12-14 year old meadow arranged on different by pH<sub>KCl</sub> and N fertilisation *Haplic-Luvisol* in 2003-2005. According to average data in N<sub>0</sub>P<sub>60</sub>K<sub>60</sub> fertilisation background ion concentrations in leachate varied: NO<sub>3</sub><sup>-</sup> 2.8–11.3, PO<sub>4</sub><sup>3-</sup> 0.07–0.24, K<sup>+</sup> 1.1–2.7, Ca<sup>2+</sup> 137–202, Mg<sup>2+</sup> 11.6–19.5 mg l<sup>-1</sup> and in N<sub>120</sub>P<sub>60</sub>K<sub>60</sub> – NO<sub>3</sub><sup>-</sup> 4.6–10.1, PO<sub>4</sub><sup>3-</sup> 0.05–0.25, K<sup>+</sup> 0.8–3.4, Ca<sup>2+</sup> 85–224, Mg<sup>2+</sup> 10.4–18.6 mg l<sup>-1</sup>. The concentrations depended on leachate sampling time, fertilisation with N<sub>120</sub> and soil pH<sub>KCl</sub>. Ca<sup>2+</sup> ion concentrations in the leachate increased when soil acidity decreased and were the highest in 6.6-7.0 pH<sub>KCl</sub> level in both fertilisation backgrounds. The highest Mg<sup>2+</sup> concentrations in spring were determined in 6.1-6.5 and 6.6-7.0 pH<sub>KCl</sub> levels and in summer and autumn periods – in 5.1-5.5 and 5.6-6.0 pH<sub>KCl</sub> levels. NO<sub>3</sub><sup>-</sup> concentrations were the highest in summer leachate samples from 5.1-5.5 and 5.6-6.0 pH<sub>KCl</sub> levels. Significant PO<sub>4</sub><sup>3-</sup> ion concentration differences depending on soil pH<sub>KCl</sub> were not determined. Higher PO<sub>4</sub><sup>3-</sup> concentrations were determined in the leachate percolated through N<sub>0</sub>P<sub>60</sub>K<sub>60</sub> background soil in spring. The highest K<sup>+</sup> concentrations were determined in 5.6-6.0 pH<sub>KCl</sub> level in summer.

Keywords: leaching, ion concentrations, soil pH<sub>KCl</sub>, liming, fertilisation

## Introduction

Nowadays many studies are focused on nitrate leaching from soils under meadows. However, the findings on phosphorus, potassium, calcium and magnesium ion leaching are limited.

Chemical and natural substances, used unreasonably in agro ecosystems, lead to ion concentrations increase in soil water. It may result in threat for human health. Elevated nitrate concentrations may cause methaemoglobinemia or even stomach cancer (Heinrich and Hergt, 2000). However, Addistott (1999) findings are not in full agreement with Heinrich and Hergt (2000). N. Jatulienė *et al.* (2001) have noted that hardness of ground and well water is a result of increased Ca<sup>2+</sup> and Mg<sup>2+</sup> ion concentrations mainly. It may cause a high incidence rate of cardiovascular and urinary system diseases.

Soils in Lithuania are under effect of elevated precipitation amounts. Percolating water leaches soil to ground water level. Therefore, part of nutrients (N, P, K, Ca, Mg, S,...) leaches from the soil. Nutrient leaching depends on soil type, soil chemical properties, meteorological conditions, grown plants, rates of applied fertilisers and lime materials and etc. (Gužys, 2001; Adomaitis *et al.*, 2004).

Consequently, the purpose of the research was to determine to which pH<sub>KCl</sub> level soils under sward agro ecosystems should be limed so that leached ion concentrations should not increase or even decrease.

## Materials and methods

Research site was in the eastern part of sea-coast lowland with moderately warm climate in Western Lithuania. The trial was carried out on 12-14 year old meadow, arranged on different by  $\text{pH}_{\text{KCl}}$  and nitrogen fertilisation *Haplic-Luvisol* in 2003-2005. The soil was loamy with primary excess acidity up to 5.5  $\text{pH}_{\text{KCl}}$ . Low or medium amounts of mobile  $\text{P}_2\text{O}_5$  (72.5-127.0  $\text{mg kg}^{-1}$ ) and mobile  $\text{K}_2\text{O}$  (74.0-149.5  $\text{mg kg}^{-1}$ ) were determined in arable soil layer. Carbonates occurred in 0.76-1.00 m depth and ground water in 1.2 m depth.

Liming established four different  $\text{pH}_{\text{KCl}}$  levels (5.0-5.5; 5.6-6.0; 6.1-6.5 and 6.6-7.0). Ground limestone was applied and introduced into the topsoil (10 cm depth) before sward sowing in spring 1991. Limestone rate was calculated according to the titration curves (Remezov method), neutralizing soil with 0.033 N  $\text{CaCl}_2$  solution. Two field trials with different fertilisation rates ( $\text{P}_{60}\text{K}_{60}$  and  $\text{N}_{120}\text{P}_{60}\text{K}_{60}$ ) were observed. Ammonium nitrate was applied in two equal parts: after 1<sup>st</sup> and 2<sup>nd</sup> cuts. Ecological phosphorus (bone-dust) and potassium (potassium magnesium) fertilisers were applied early in spring before grass growth resumed after winter. Lysimeters (Shilova type) were installed at 40 cm depth. Treatments were replicated threefold. Lysimeter water samples were collected in spring, summer and autumn of 2003-2005. Ion concentrations in leached water were measured by following methods:  $\text{NO}_3^-$  and  $\text{PO}_4^{3-}$  – colorimetric,  $\text{K}^+$  – flame photometric,  $\text{Ca}^{2+}$  and  $\text{Mg}^{2+}$  – trilonometric.

## Results and discussion

Research soil received high precipitation amount (767.8 mm, 904.1 mm and 990.5 mm per 2003, 2004 and 2005 respectively). Therefore, risk of nutrient leaching occurred.

It follows from Tables 1 and 2, that  $\text{NO}_3^-$  concentrations in all treatments were below the limit of 50  $\text{mg l}^{-1}$ . Average  $\text{NO}_3^-$  concentrations in the leachate varied from 2.8 to 11.3  $\text{mg l}^{-1}$ , when meadow was fertilised with  $\text{P}_{60}\text{K}_{60}$ , and from 4.6 to 10.1  $\text{mg l}^{-1}$ , when fertilised with  $\text{N}_{120}\text{P}_{60}\text{K}_{60}$ .

Table 1. Average ion concentrations in the leachate, percolated through fertilised with  $\text{P}_{60}\text{K}_{60}$  soil for the period 2003-2005.

Leached ions	Concentrations, $\text{mg l}^{-1} \pm S_x$			
	$\text{pH}_{\text{KCl}}$ 5.0-5.5	$\text{pH}_{\text{KCl}}$ 5.6-6.0	$\text{pH}_{\text{KCl}}$ 6.0-6.5	$\text{pH}_{\text{KCl}}$ 6.6-7.0
	spring			
$\text{NO}_3^-$	5.5±2.1	6.3±2.0	5.3±2.0	6.5±2.0
$\text{PO}_4^{3-}$	0.22±0.05	0.24±0.04	0.19±0.04	0.20±0.04
$\text{K}^+$	1.4±0.3	1.9±0.3	1.4±0.3	1.8±0.5
$\text{Ca}^{2+}$	164±11.2	169±12.4	182±16.8	189±20.5
$\text{Mg}^{2+}$	11.6±1.5	12.8±2.0	14.3±2.2	18.6±4.1
	summer			
$\text{NO}_3^-$	9.7±1.8	11.3±2.8	6.2±0.6	6.0±1.0
$\text{PO}_4^{3-}$	0.08±0.03	0.09±0.02	0.07±0.02	0.13±0.04
$\text{K}^+$	2.1±0.2	2.7±0.5	1.8±0.4	2.0±0.2
$\text{Ca}^{2+}$	148±25.2	137±15.6	168±30.0	189±48.5
$\text{Mg}^{2+}$	17.6±4.2	17.5±2.9	15.6±4.0	13.3±2.6
	autumn			
$\text{NO}_3^-$	3.7±0.4	3.1±0.3	2.8±0.2	3.6±0.5
$\text{PO}_4^{3-}$	0.16±0.04	0.18±0.05	0.16±0.04	0.18±0.06
$\text{K}^+$	1.6±0.2	1.5±0.2	1.1±0.2	1.6±0.3
$\text{Ca}^{2+}$	146±12.6	180±16.2	202±18.4	198±25.0
$\text{Mg}^{2+}$	16.1±1.8	19.5±2.8	17.3±2.1	15.8±2.0

The highest nitrate concentrations (6.0-11.3  $\text{mg l}^{-1}$  and 7.2-10.1  $\text{mg l}^{-1}$  from  $\text{P}_{60}\text{K}_{60}$  and  $\text{N}_{120}\text{P}_{60}\text{K}_{60}$  backgrounds respectively) were determined in summer leachate samples. While

the lowest  $\text{NO}_3^-$  concentrations (2.8-3.7  $\text{mg l}^{-1}$  and 5.2-7.1  $\text{mg l}^{-1}$  from  $\text{P}_{60}\text{K}_{60}$  and  $\text{N}_{120}\text{P}_{60}\text{K}_{60}$  backgrounds respectively) were determined in autumn leachate samples. Fertilising with  $\text{N}_{120}\text{P}_{60}\text{K}_{60}$  higher  $\text{NO}_3^-$  concentrations were established in the leachate, percolated through 5.1-5.5 and 5.6-6.0  $\text{pH}_{\text{KCl}}$  level soil. However, no clear tendency was determined at  $\text{P}_{60}\text{K}_{60}$  fertilisation background.  $\text{NO}_3^-$  concentrations were lower in the leachate, percolated through 6.1-6.5 and 6.6-7.0  $\text{pH}_{\text{KCl}}$  level soil under both fertilisation levels. Fertilisation with  $\text{N}_{120}\text{P}_{60}\text{K}_{60}$  slightly increased  $\text{NO}_3^-$  concentrations in the leached water. However, fertilisation with ammonium nitrate at a rate of 120  $\text{kg N ha}^{-1}$  did not lead to soil water contamination with  $\text{NO}_3^-$ .

$\text{PO}_4^{3-}$  ion concentrations in the leachate were the lowest if comparing to other considered biogenic element concentrations (Tables 1 and 2).  $\text{PO}_4^{3-}$  ion concentrations in lysimetric water, percolated through  $\text{P}_{60}\text{K}_{60}$  fertilised soil, varied from 0.07 to 0.24  $\text{mg l}^{-1}$ , and fertilising with  $\text{N}_{120}\text{P}_{60}\text{K}_{60}$  – from 0.05 to 0.25  $\text{mg l}^{-1}$ . Fertilising with  $\text{P}_{60}\text{K}_{60}$  the highest  $\text{PO}_4^{3-}$  concentration (0.24  $\text{mg l}^{-1}$ ) was established in the leachate, percolated through 5,6-6,0  $\text{pH}_{\text{KCl}}$  level soil, in spring and the lowest (0.07  $\text{mg l}^{-1}$ ) – in the leachate, percolated through 6.1-6.5  $\text{pH}_{\text{KCl}}$  level soil, in summer. Significant  $\text{PO}_4^{3-}$  ion concentration differences depending on soil  $\text{pH}_{\text{KCl}}$  were not determined at  $\text{N}_{120}\text{P}_{60}\text{K}_{60}$  fertilisation background.

Table 2. Average ion concentrations in the leachate, percolated through fertilised with  $\text{N}_{120}\text{P}_{60}\text{K}_{60}$  soil for the period 2003-2005.

Leached ions	Concentrations, $\text{mg l}^{-1} \pm S_x$			
	$\text{pH}_{\text{KCl}}$ 5.0-5.5	$\text{pH}_{\text{KCl}}$ 5.6-6.0	$\text{pH}_{\text{KCl}}$ 6.0-6.5	$\text{pH}_{\text{KCl}}$ 6.6-7.0
	spring			
$\text{NO}_3^-$	6.1±2.5	7.2±3.2	4.6±1.3	6.7±2.6
$\text{PO}_4^{3-}$	0.18±0.04	0.19±0.06	0.13±0.02	0.20±0.06
$\text{K}^+$	1.4±0.4	2.2±0.9	1.3±0.5	1.2±0.4
$\text{Ca}^{2+}$	119±15.9	111±29.3	161±31.5	180±20.5
$\text{Mg}^{2+}$	11.6±2.0	11.7±1.3	12.1±2.9	13.0±3.0
	summer			
$\text{NO}_3^-$	10.1±2.3	8.4±0.4	8.5±1.8	7.2±2.1
$\text{PO}_4^{3-}$	0.25±	0.18±0.06	0.10±	0.05±0.00
$\text{K}^+$	2.3±0.4	3.4±1.2	2.2±1.2	1.0±0.2
$\text{Ca}^{2+}$	85±14.4	88±22.2	150±61.8	224±36.9
$\text{Mg}^{2+}$	15.2±4.6	10.4±1.2	16.3±3.4	12.5±2.2
	autumn			
$\text{NO}_3^-$	5.0±0.7	7.1±1.3	5.6±1.7	5.2±1.0
$\text{PO}_4^{3-}$	0.16±0.03	0.23±0.07	0.11±0.03	0.14±0.04
$\text{K}^+$	1.3±0.1	1.7±0.2	0.9±0.2	0.8±0.1
$\text{Ca}^{2+}$	159±16.0	187±15.1	185±34.5	220±13.2
$\text{Mg}^{2+}$	16.7±1.3	17.1±2.8	18.6±3.1	18.3±1.9

Data from Tables 1 and 2 showed that  $\text{K}^+$  ion leaching was one of the least. When meadow was fertilised with  $\text{P}_{60}\text{K}_{60}$  they varied from 1.1 to 2.7  $\text{mg l}^{-1}$ , and at  $\text{N}_{120}\text{P}_{60}\text{K}_{60}$  background – from 0.8 to 3.4  $\text{mg l}^{-1}$ . The highest  $\text{K}^+$  ion concentrations were established in spring leachate (1.8-2.7 at  $\text{P}_{60}\text{K}_{60}$  and 1.0-3.4 at  $\text{N}_{120}\text{P}_{60}\text{K}_{60}$  backgrounds respectively). While the lowest  $\text{K}^+$  concentrations (0.16-0.18 at  $\text{P}_{60}\text{K}_{60}$  and 0.8-1.7 at  $\text{N}_{120}\text{P}_{60}\text{K}_{60}$  backgrounds respectively) were determined in autumn. The highest  $\text{K}^+$  concentrations were determined in 5.6-6.0  $\text{pH}_{\text{KCl}}$  level in summer. When soil  $\text{pH}_{\text{KCl}}$  was approaching to neutral (5.0→7.0)  $\text{K}^+$  concentrations in the leachate tended to decrease slightly fertilising both  $\text{P}_{60}\text{K}_{60}$  and  $\text{N}_{120}\text{P}_{60}\text{K}_{60}$ . Skowron and Sykut (2005) have noted similar tendency.

Data from Tables 1 and 2 showed, that  $\text{Ca}^{2+}$  ion concentrations in the leachate were the highest if comparing to other considered ion concentrations. The concentrations in the leachate, percolated through soil under  $\text{P}_{60}\text{K}_{60}$  and  $\text{N}_{120}\text{P}_{60}\text{K}_{60}$  fertilisation, varied from 137 to 202  $\text{mg l}^{-1}$  and from 85 to 224  $\text{mg l}^{-1}$  respectively.  $\text{Ca}^{2+}$  concentrations were the highest (189-

202 mg l<sup>-1</sup>) in lysimeter water samples, which percolated through 6,1-6,5 and 6,6-7,0 pH<sub>KCl</sub> level soil when fertilising with P<sub>60</sub>K<sub>60</sub>. At N<sub>120</sub>P<sub>60</sub>K<sub>60</sub> fertilisation background the highest (180-224 mg l<sup>-1</sup>) Ca<sup>2+</sup> concentrations were determined in the leachate, percolated through soil, which was limed to 6.6-7.0 pH<sub>KCl</sub>.

Meadow fertilisation with N<sub>120</sub>P<sub>60</sub>K<sub>60</sub> resulted in lower Ca<sup>2+</sup> ion concentrations than fertilising with P<sub>60</sub>K<sub>60</sub> (Tables 1 and 2). However, contradictory data in leachate samples, which were collected in autumn, were obtained. When soil pH<sub>KCl</sub> was approaching to neutral (5.0→7.0) Ca<sup>2+</sup> ion concentrations in leachate increased when fertilised with both P<sub>60</sub>K<sub>60</sub> (insignificant correlation) and N<sub>120</sub>P<sub>60</sub>K<sub>60</sub> (r<sub>spring</sub> 0,579\*-0,681\* and r<sub>autumn</sub> 0,585\*-0,685\*). Limestone application increased Ca<sup>2+</sup> concentrations in the leachate, percolated through meadow soil. Strong correlation was derived between Mg<sup>2+</sup> and Ca<sup>2+</sup> ion concentrations in the leachate (r 0,735\*\*,-0,776\*\*). Čiuberkienė and Ežerinskas (2000) have noted similar relationships.

Mg<sup>2+</sup> ion concentrations in water samples varied from 11.6 to 19.5 mg l<sup>-1</sup> and from 10.4 to 18.6 mg l<sup>-1</sup> at P<sub>60</sub>K<sub>60</sub> and N<sub>120</sub>P<sub>60</sub>K<sub>60</sub> fertilised meadow respectively (Tables 1 and 2). The highest Mg<sup>2+</sup> concentrations (15.8-19.5 mg l<sup>-1</sup> and 16.7-18.6 mg l<sup>-1</sup> from P<sub>60</sub>K<sub>60</sub> and N<sub>120</sub>P<sub>60</sub>K<sub>60</sub> backgrounds respectively) were determined in autumn and the least (11.6-14.3 mg l<sup>-1</sup> and 11.6-13.0 mg l<sup>-1</sup> from P<sub>60</sub>K<sub>60</sub> and N<sub>120</sub>P<sub>60</sub>K<sub>60</sub> backgrounds respectively) – in spring. Clear tendencies of pH<sub>KCl</sub> level effect on Mg<sup>2+</sup> ion concentrations were not determined.

## Conclusions

Three year average data showed, that Ca<sup>2+</sup> and Mg<sup>2+</sup> ion concentrations in the leachate were the highest, however, Mg<sup>2+</sup> concentrations were less than Ca<sup>2+</sup>. Limestone application increased Ca<sup>2+</sup> and Mg<sup>2+</sup> ion concentrations in the leachate, percolated through meadow soil. Fertilisation with N<sub>120</sub>P<sub>60</sub>K<sub>60</sub> slightly increased NO<sub>3</sub><sup>-</sup> concentrations in the leached water. NO<sub>3</sub><sup>-</sup> concentrations in all treatments were below the limit of 50 mg l<sup>-1</sup>. PO<sub>4</sub><sup>3-</sup> and K<sup>+</sup> ion concentrations were the lowest if comparing to other considered ion concentrations. Consequently, considered ion concentrations were the lowest in the leachate, percolated through soil limed to 5.1-5.5 pH<sub>KCl</sub> level. Limestone and NPK fertiliser application slightly increased ion concentrations.

## References

- Addiscott T. M. (1999) Nitrate and health: introductory comments. In: R. H. Hinton. Managing risks of nitrates to humans and the environment. The Royal Society of Chemistry, Cambridge, pp. 247-299.
- Adomaitis T., Vaišvila Z., Mažvila J., Grickevičienė S. and Eitminavičius L. (2004) Concentration of nitrogen (NO<sub>3</sub><sup>-</sup>, NH<sub>4</sub><sup>+</sup>, NO<sub>2</sub><sup>-</sup>) compounds in lysimeter water of a differently fertilized sandy loam soil. *Agriculture. Scientific Articles*, 88 (4), 21-33.
- Čiuberkienė D. and Ežerinskas V. (2000) The change of agrochemical properties and nutrient migration in differently limed and fertilized soil. *Agriculture. Scientific articles*, 71, 32-48.
- Gužys S. (2001) The runoff of drainage water, migration and balance of chemical elements in the conditions of biological and intensive cropping systems in the soils of Western Lithuania. *Agriculture. Scientific articles*, 74, 53-69.
- Heinrich D. and Hergt M. (2000) *Ecology atlas*. Vilnius: Alma littera, pp. 186-187.
- Jatulienė N., Petkevičius R. and Regalienė G. (2001) Regional development and population health. In: Sustainable Development in the Information Society. *Proceedings of the International Conference*, October 3-5, 2000, Vilnius, Lithuania, pp. 276-282.
- Skowron P. and Sykut S. (2005) Influence of acidification on the leaching of nutrient in lysimeter experiment. *Höhere Bundeslehr – und Forschungsanstalt für Landwirtschaft*, A-8952 Irdning, 11 Gumpensteiner Lysimetertagung, 207-211.

# Effects of fertilization scheme on grassland production and water environment

Szewczyk W., Kasperczyk M. and Kacorzyk P.

*Department of Grassland Sciences, Agricultural University of Cracow, al. Mickiewicza 21, PL 31-120 Krakow, Poland*

## Abstract

The investigations were conducted in 2003-2005 on the mountain meadow (altitude of 640 m). Experimental field was located on the brown soil. Three fertilization dressings were applied: mineral, farmyard manure, and mixed (mineral and farmyard manure). The meadow was mown twice in the summer and the floristic composition of the sward was assessed before the first harvesting. Lysimeters collecting soaking water were situated at the depth of 45 cm. In the control sward *Festuca rubra* L. and *Agrostis capillaris* L. were dominating grass species. They constituted 38% and 14% of the sward yield, respectively. Dominating grass species in fertilized objects were *Festuca pratensis* With., *Festuca rubra* L., *Agropyron repens* L. and *Poa pratensis* L. Mineral and mixed mineral and manure fertilization, which provided similar amounts of fertilization components, nearly doubled the dry matter (DM) yield the meadow. The highest amounts of nitrogen, phosphorus, potassium, calcium and sodium in soaking water were found for the meadow treated with mineral and mixed i.e.: manure and mineral fertilizers. Obtained results suggest that the sward, where mineral fertilizers were applied had the best characteristics when it comes to the level of yield but water of this object was the richest in nitrogen and phosphorus, which are the factors deciding about eutrophication of river water. The sward fertilized with manure contained the lowest level of components and its input into supplying groundwater was of the smallest importance.

Keywords: mountain meadow, fertilization, dry mass, lysimetric water

## Introduction

Meadows and pastures cover about 40% of the mountain area and together with forests they are very important ecosystems of this region. Grasslands not only provide valuable forage but also play a very important role connected with their hydrological function (Kasperczyk *et al.*, 2005, Orlik *et al.*, 2001, Paruch *et al.*, 2001). They decide about quantity and quality of outflow water supplying rivers. The main factor affecting this performance of grasslands is the floristic composition of the sward, which is the resultant of management and fertilization method. The task is to create such a composition, which will ensure high forage yields and maximum reduction of groundwater pollution in water catchments areas (Jagus and Twardy, 2004, Seidel *et al.*, 2004).

The aim of the conducted study was to estimate the effect of kind of fertilization on the floristic composition and yield of the meadow sward, as well as quantity and quality of water passing through the soil profile.

## Material and methods

The investigations were conducted in 2003-2005 on the mountain meadow (altitude of 640 m) near Krynica (49°24' N, 20°55' E). The experimental field was located on the brown soil of granulometric composition of clayey sand. Soil chemical characteristics were as follows:

pH=4.3, available P=8.0, K=56 and Mg=54 mg kg<sup>-1</sup>. Sixteen lysimeters collecting soaking water, 0.45 m deep and with a surface area of 0.3 m<sup>2</sup>, were used. The bottom 0.05 m was filled with gravel, to allow drainage toward the pipe and avoid clogging, the upper 0.4 m of the lysimeters was filled with a soil, taken from the profile on site including natural sod. Each lysimeter was connected by an underground pipe to an external tank to measure water output and collect water samples. Water measurements were done from the middle of April to the end of September each year. Four experimental meadow objects were taken into account in our investigations. The plot size was 20 m<sup>2</sup> (4 m × 5 m) and there were four replicates in complete block design. Fertilizers were applied in each year of the study. In mineral fertilization phosphorus (18 kg P ha<sup>-1</sup>) and potassium (50 kg K ha<sup>-1</sup>) were applied once in the spring, whereas nitrogen fertilizers (100 kg N ha<sup>-1</sup>) were used twice: 60% of the whole amount for the first regrowth and 40% for the second regrowth. Sheeps 's manure (FYM) was applied in the spring. Its chemical composition was as follows: total N – 0.69, P – 0.14, K – 0.55, Ca – 0.35 and Mg – 0.18% in fresh mass. The farmyard manure fertilization at the rate of 10 t ha<sup>-1</sup> supplied 69 kg N, 14 kg P and 55 kg K. Under the manure-mineral fertilization, doses of nitrogen and phosphorus were supplemented with mineral fertilizers to the amounts used in the mineral fertilized object. The meadow was mown twice in the summer and the floristic composition of the sward was assessed before the first regrowth was collected.

## Results and discussion

In the control sward *Festuca rubra* L. and *Agrostis capillaris* L. were dominating grass species. They constituted 38% and 14% of the sward yield, respectively (Table 1). Other species occurring in smaller quantities (1-9%) were: *Alchemilla pastoralis* L., *Cynosurus cristatus* L., *Festuca pratensis* With., *Poa pratensis* L. and *Trifolium repens* L. Dominating grass species in fertilized objects were *Festuca pratensis* With., *Festuca rubra* L., *Agropyron repens* L. and *Poa pratensis* L. Mineral or manure fertilization were particularly beneficial for *Agropyron repens* L. and *Poa pratensis* L. growth.

Table 1. The percentage of most important plant species in the sward (weight percentages on total dry matter yield - average for 3 years)

Species	Fertilization			
	0 - Control	P <sub>18</sub> K <sub>50</sub> N <sub>100</sub>	FYM 10 t ha <sup>-1</sup> (P <sub>14</sub> K <sub>55</sub> N <sub>69</sub> )	FYM +P <sub>4</sub> N <sub>31</sub>
<i>Festuca rubra</i>	38	10	15	10
<i>Agrostis capillaris</i>	14	1	4	5
<i>Festuca pratensis</i>	4	39	30	32
<i>Poa pratensis</i>	3	11	9	9
<i>Agropyron repens</i>	1	15	7	4
<i>Trifolium repens</i>	8	2	9	5
<i>Alchemilla pastoralis</i>	9	4	6	6
<i>Achillea millefolium</i>	3	4	6	5

During three years of investigations, mineral, and mixed mineral and manure fertilization, which provided similar amounts of fertilization components, nearly doubled the yield of the meadow (Table 2). The sward fertilized with manure alone was characterised with a 64% higher yield. In 2003, due to insufficient amounts of rainfall, the meadow yield was significantly lower than in 2004 and 2005. Mineral fertilized sward was the most influenced by the shortage of rainfall and the opposite relation was observed for the sward where manure and mineral fertilizers were used together. In the first case yield in 2003, in relation to the yield obtained in 2004, was lower by 30%, in the second case – by 16%.



Table 2. Dry matter yields (t ha<sup>-1</sup>)

Fertilization	Years			
	2003	2004	2005	Mean
0 - Control	2.80	3.27	4.94	3.67
P <sub>18</sub> K <sub>50</sub> N <sub>100</sub>	5.07	7.25	9.01	7.11
FYM 10 t ha <sup>-1</sup> (P <sub>14</sub> K <sub>55</sub> N <sub>69</sub> )	4.37	6.08	7.62	6.02
FYM +P <sub>4</sub> N <sub>31</sub>	5.84	6.90	8.19	6.98
LSD <sub>p=0.05</sub>	0.78	0.93	1.76	1.16

Indexes of rain water outflow from the meadow soil profile in 2003 were almost 2-times lower in comparison to the values obtained in 2004 and 2005 (Table 3). It was due to the fact that, total quantity of rainfall in the first year amounted to 511 mm and during the second and third year it was equal to 699 mm and 668 mm respectively. During 2003 - 2005, the highest level of rain water passing through the soil profile was noticed for the meadow treated with mineral fertilizers (15.3%) and the lowest – for control object (9.4%). In meadows fertilized with manure alone or together with mineral fertilizers outflow index reached similar value of 10.9 - 11.0%.

Table 3. Amount of rainfall and indexes of rain water outflow from the soil profile

Item	Years			Mean
	2003	2004	2005	
Amount of rainfall (mm)	511	699	668	626
	Outflow coefficient (%)			
0 - Control	5.8	8.6	13.8	9.4
P <sub>18</sub> K <sub>50</sub> N <sub>100</sub>	7.5	18.7	19.7	15.3
FYM 10 t ha <sup>-1</sup> (P <sub>14</sub> K <sub>55</sub> N <sub>69</sub> )	5.7	11.3	16.0	11.0
FYM +P <sub>4</sub> N <sub>31</sub>	6.3	10.2	16.1	10.9

The highest amounts of phosphorus, potassium and calcium in soaking water were found for the meadow treated with mixed i. e.: manure and mineral fertilizers (Table 4). Soaking water from the meadow where mineral fertilizers were applied was the richest in nitrogen, magnesium and contained substantial amounts of sodium. The lowest values of leached nutrients were obtained for the unfertilized (control) object and for the meadow fertilized with manure only.

Such high calcium concentration in percolating water from manured plots indicate that it was only in small amounts absorbed by the soil complex from the manure. The highest value of the rain water outflow index as well as the highest amount of mineral components found in water under the meadow mineral fertilized can be confirmed by the results obtained by Jagus and Twardy (2004).

Table 4. Concentration of chemical components in soaking water (average for 3-years period)

Fertilization	mg dm <sup>3</sup>						
	NH <sup>+4</sup>	NO <sup>-3</sup>	P	K	Ca	Mg	Na
0 - Control	1.10	3.95	0.15	2.61	7.10	0.97	0.62
P <sub>18</sub> K <sub>50</sub> N <sub>100</sub>	1.85	6.36	0.36	1.86	14.8	1.94	1.10
FYM 10 t ha <sup>-1</sup> (P <sub>14</sub> K <sub>55</sub> N <sub>69</sub> )	0.44	2.57	0.30	0.80	16.1	1.86	0.76
FYM +P <sub>4</sub> N <sub>31</sub>	1.10	3.89	0.50	2.76	20.3	1.23	0.96

## Conclusions

The obtained results suggest that the sward, where mineral fertilizers were applied was the most productive but also most prone to leaching of nutrients. Water of this object was the richest in ammonium and nitrate nitrogen as well as phosphorus, which are the main factors

deciding about eutrophication of river water. The opposite characteristic was found for the sward fertilized with manure because having acceptable DM yield it contained the lowest level of components and its input into supplying underground water was of the smallest importance. In order to minimize ground water pollution and by a moderate input of farmyard manure might be most appropriate for sites with similar conditions.

## References

- Jagus A. and Twardy S. (2004) The influence of cutting frequency of a mountain meadow on yield and chemical composition of percolating waters (Lysimeter studies). *Water – Environment – Rural Areas*, 4/1, 125-137.
- Kasperczyk M., Szewczyk W. and Kacorzyk P. (2005) Production and ecological value of the mountain meadow depending on the kind of fertilization. *Proceedings of Ekotrend 2005*, “Renewal and function of anthropogenic landscape”, 141-145.
- Orlik T., Jozwiakowski K. and Marzec M. (2001) Influence of grasslands on reduction of the area pollution originating from agriculture. *Zesz. Nauk. AR Krakow*, 382, 13-20.
- Paruch A., Paluch J. and Pulikowski K. (2001) Chemical composition of drainage runoffs out of objects situated in the south-west Poland. *Zesz. Nauk. AR Krakow*, 382, 49-56.
- Seidel K., Kayser M. and Isselstein J. (2004) Nitrate leaching from reseeded grassland: The effect of season, technique of renewal and former N fertilization. *Grassland Science in Europe*, 9, 349-351.

# Organic fertilization and biodiversity of *Festuca rubra* grasslands

Păcurar F., Rotar I., Vidican R.

*University of Agricultural Sciences and Veterinary Medicine of Cluj-Napoca, România.*

## Abstract

In the Apuseni Mountains (Romania) the grasslands are still in use at a large scale in a traditional way. The organic fertilization is the only method of increasing the yield of fodder on a surface lot. Our studies have focused on the effect of applying three amounts of manure (10, 20 and 30 t ha<sup>-1</sup>) on the productivity and biodiversity of a *Festuca rubra* grassland from the boreal level in the period 2001-2004. The application of stable manure has a beneficial effect on the yield of dry matter (DM), the increase of yield being significant in the case of all variants in comparison to the witness variant. The dry matter yield is strongly influenced by the climatic conditions and especially by the temperature, which proved to be the limitative factor of the yield. The application of stable manure determines modifications in the grass canopy by increasing the share of participation of the Poaceae concomitantly with the increase of the amount of manure, as well as the decrease of the share of Phabaceae and the plants from other botanic families (OBF). Several species will increase proportionally with the intensification of the system, (*Agrostis capillaris*, *Centaurea pseudophrigia* etc.), while others will be reduced (*Festuca rubra*, *Trifolium pratense*, *Alchemilla vulgaris* etc.), and still others will disappear from the phytocenosis (*Anthyllis vulneraria*, *Campanula patula*, *Cerastium glomeratum* etc.). The reduction of the floral biodiversity as a consequence of the intensification of the system is outlined by the evolution of the Shannon index, which decreases proportionally with the increase of manure quantities.

Keywords: hay field, organic fertilization, yield, biodiversity

## Introduction

Large surfaces of grasslands of the area of Apuseni Mountains of Romania are still being used in a traditional manner (Reif *et al.*, 2005). This type of usage is an extensive one, the grasslands being exploited through mowing and cattle grazing. The stable manure obtained in the own farms is used as the sole fertilizer. The application of this type of management has generated a large specific richness of protected species (Rotar *et al.*, 2006, Păcurar 2005).

## Materials and methods

The experiment with organic fertilizers was started in the year 2001 on a soil of the brown eumezobasic rendzinic type, at an altitude of 1100 m. The inclination of the land is 2%, with a northern exposition, the experiment being located at the foot of the slope. Concerning the vegetation level the regions corresponds to the boreal level, while the type of grassland is *Festuca rubra*. The experiment was made according to the method of randomized plots, with four variants in four repetitions. The experimental variants are: V<sub>1</sub>-witness, V<sub>2</sub>-10 t ha<sup>-1</sup> manure, V<sub>3</sub>-20 t ha<sup>-1</sup> manure, V<sub>4</sub>-30 t ha<sup>-1</sup> manure. In this work we will present the results obtained in the period 2001-2004. The paper will also discuss the evolution of dry matter yield along the four years under study as well as the grass canopy modifications after four years of organic fertilization. During the period under study, the annual average temperature was: 5.3 °C in 2001, 6.5 °C in 2002, 5.4 °C in 2003 and 4.1 °C in 2004; the precipitations

amounted to: 1553 mm in 2001, 1200 mm in 2002, 1011mm in 2003 and 1390 mm in 2004. The brown eu-mezobazic rendzinic soil type is characterized by a humus content of 6.31%, with a total amount of: nitrogen 0.212 %, phosphor of 3 ppm (parts of a million) and potassium of 25 ppm. The sTable manure used originates from cattle and horses, being semi-fermented at the moment of application. The organic fertilization was done annually, early in spring, as a rule at the end of April. The vegetation studies were carried out with the metric frame in July, (this work will show the vegetation results of 2004). The harvest of the experimental plots was done on the flourishing moment of the Poaceae, which is in the beginning of July. Only one cut was done annually. The statistic interpretation of the results was according to the method of analysis of variation.

## Results and discussion

The application of organic fertilizers of the *Festuca rubra* grassland had an improving effect of the yield of dry matter (DM). As an average of the experimental years, the yield of dry matter increased proportionally with the increase of the amounts of sTable manure, from 2.25 t ha<sup>-1</sup> DM, from the witness case, up to 3.72 t ha<sup>-1</sup> at the usage of 30 t ha<sup>-1</sup> manure (Table 1). The yield increases were significantly different for all the treatments applied.

Table 1. The influence of organic fertilizers on DM yield (average of the years)

variant	DM t ha <sup>-1</sup>	%	diff.	Signif.
witness	2.25	100.0	0.00	-
10 t ha <sup>-1</sup> manure	2.97	131.8	0.71	*
20 t ha <sup>-1</sup> manure	3.35	148.9	1.10	**
30 t ha <sup>-1</sup> manure	3.72	165.3	1.47	***
DL(p5%) -0.58	DL(p1%) - 0.83		DL(p0.1%) - 1.22	

During the four years of the experiment, the dry matter yield was influenced by the climatic conditions. In 2002 we found far superior levels of dry matter yield in comparison with other experimental years (Figure 1). This situation could be explained by the high temperatures recorded during 2002. In our study area, temperature is the limitative factor of the dry matter yield. The evolution of the dry matter follows closely the evolution of temperature and is rather indifferent to the evolution of the precipitations. (Figure 2).

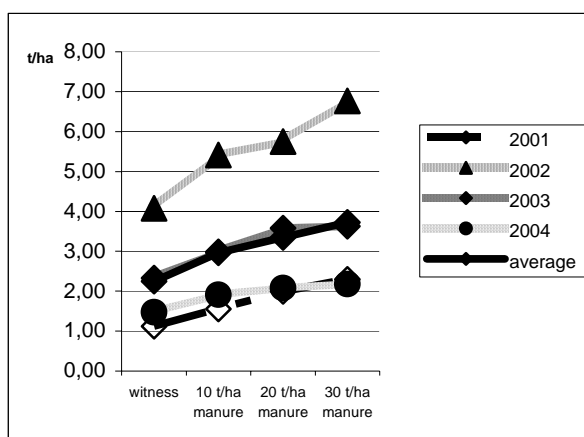

Figure 1. Evolution of yield during the experimental years

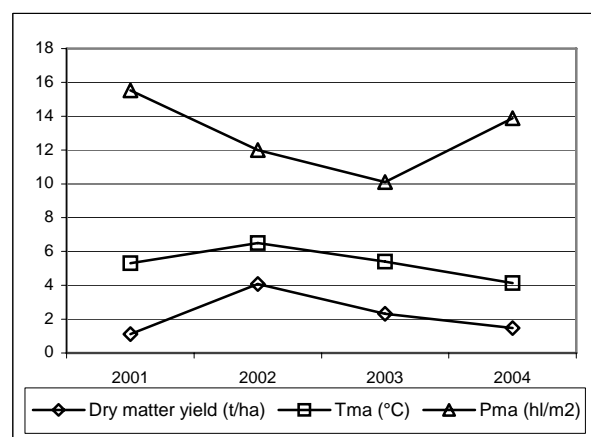

Figure 2. Relation between dry matter yield and the evolution of temperatures and precipitations (witness)

Table 2. The influence of organic fertilizers on the degree of covering

	Witness	10 t ha <sup>-1</sup> manure	20 t ha <sup>-1</sup> manure	30 t ha <sup>-1</sup> manure
Covering %				
Species %	87.0	90.0	93.0	90.0
<i>Poaceae</i>	24.2	26.2	40.6	40.6
<i>Agrostis capillaris</i>	4.8	7.9	11.9	8.3
<i>Anthoxanthum odoratum</i>	3.2	3.1	4.4	3.3
<i>Cynosurus cristatus</i>	3.2	2.1	1.7	0.6
<i>Festuca pratensis</i>	4.2	2.9	5.8	5.1
<i>Festuca rubra</i>	5.1	2.9	2.9	3.4
<i>Poa trivialis</i>	0.1	0.1	0.5	1.0
<i>Trisetum flavescens</i>	3.6	7.3	13.4	19.1
<i>Phabaceae</i>	19.7	18.1	18.7	10.9
<i>Anthyllis vulneraria</i>	0.2			
<i>Lathyrus pratensis</i>		0.4	0.2	
<i>Lotus corniculatus</i>	1.2	2.1	1.7	1.7
<i>Medicago lupulina</i>	0.4			
<i>Trifolium pratense</i>	4.5	2.7	5.6	4.0
<i>Trifolium repens</i>	13.6	12.8	11.3	5.2
<i>Cyperaceae and Juncaceae</i>	0.1	0.2	0.8	0.0
<i>Carex pallescens</i>	0.1	0.1	0.3	
<i>Luzula campestris</i>		0.1	0.5	
<i>Other botanic families</i>	50.1	48.3	43.0	34.5
<i>Achillea millefolium</i>	5.0	2.6	2.8	1.3
<i>Alchemilla vulgaris</i>	8.1	1.6	2.8	2.3
<i>Arabis hirsute</i>	0.1	0.1	0.1	0.1
<i>Campanula patula</i>	0.1	0.2		
<i>Carlina acaulis</i>	0.8	0.2	0.6	0.6
<i>Carum carvi</i>	0.2	1.1	0.9	0.5
<i>Centaurea pseudophrygia</i>	4.6	18.6	11.8	6.1
<i>Cerastium glomeratum</i>	0.3	0.2	0.2	
<i>Colchicum autumnale</i>	1.1	2.4	1.4	0.7
<i>Crepis biennis</i>	1.4	0.5	1.1	0.2
<i>Hieracium aurantiacum</i>	0.4	0.9		
<i>Hypericum maculatum</i>	5.4	0.5	0.6	0.6
<i>Leontodon autumnale</i>	0.1			
<i>Leontodon hispidus</i>	3.1	1.9	1.7	0.4
<i>Leucanthemum vulgare</i>	0.9	0.5	0.2	0.6
<i>Pimpinella major</i>	2.5	0.9	2.6	1.6
<i>Plantago lanceolata</i>	1.4	1.6	0.6	0.7
<i>Plantago media</i>	1.9	0.6	0.8	0.1
<i>Polygala vulgaris</i>	0.2	0.1	0.1	0.1
<i>Ranunculus acris</i>	1.1	0.6	0.4	0.4
<i>Rhinanthus minor</i>	3.4	2.1	3.0	2.3
<i>Rumex acetosa</i>	0.6	0.1	0.8	0.1
<i>Sanguisorba minor</i>				0.1
<i>Stellaria graminea</i>	2.4	5.1	5.6	12.1
<i>Taraxacum officinale</i>	0.8	1.2	0.4	0.3
<i>Veronica chamaedrys</i>	4.4	4.5	4.8	3.3
Total number of species	38.0	37.0	35.0	32.0
Species which disappear from the grass canopy		3.0	5.0	9.0
Species that enter the grass canopy		2	2	1
Shanon Index	3.302	2.932	3.119	2.63

Through the application of the sTable manure after four years important changes were noticed in the botanical composition. The participation of the Poaceae was increased proportionally with the increase of the amounts of fertilizers. from 24.2 % (witness) up to 40.6 % (at the variant with 30 t ha<sup>-1</sup> manure). Several species of Poaceae visibly increased their share (*Agrostis capillaris* and *Trisetum flavescens*), still others decreased (*Cynosurus cristatus* and *Festuca rubra*), while others remain almost the same (*Anthoxanthum odoratum*, *Festuca pratensis* and *Poa trivialis*). As the system became more intensive a stronger installation of the nitrogen likeable species (*Agrostis capillaris* and *Trisetum flavescens*) was noticed. The Phabaceae reduced proportionally with the increase of the manure amount, from 19.7 % (witness) down to 10.9 % (variant with 30 t ha<sup>-1</sup> manure). Among the Phabaceae species only *Lotus corniculatus* increased, while the other species decreased (*Trifolium pratense* and *Trifolium repens*). Some species even disappeared from the grass canopy (*Anthyllis vulneraria*, *Lathyrus pratensis* and *Medicago lupulina*). The *Cyperaceae* and the *Juncaceae* reduced their participation, while at the application of the maximal amounts of manure they completely disappeared from the phitocenosis. The importance of plants belonging to other botanic families (OBF) decreased as the system became more intensive from 50.1 % at the witness down to 34.5 % at in the case of the variant with 30 t ha<sup>-1</sup> manure. Only two species of OBF increased their share as the manure amounts increase (*Centaurea pseudophrigia*, *Stellaria graminea*). The species with reduced presence were: *Alchemilla vulgaris*, *Carlina acaulis*, *Crepis biennis*, *Hypericum maculatum*, *Rhinanthus minor* etc. Some species disappeared from the grass canopy by the application of various quantities of manure, as follows: *Leontodon autumnale* – at the variant with 10 t ha<sup>-1</sup> manure *Campanula patula* and *Hieracium aurantiacum* – at the variant with 20 t ha<sup>-1</sup> manure, while *Cerastium glomeratum* – at the treatment with 30 t ha<sup>-1</sup> manure. The restraints within the grass canopy were emphasized by the evolution of the Shannon index, reducing its values concomitantly with the increase of the amounts of organic fertilizer, from 3.302 (witness) down to 2.63 (variant with 30 t ha<sup>-1</sup> manure).

## Conclusions

Applying manure on *Festuca rubra* grassland, generated an increase of the dry matter production up to 3.72 t ha<sup>-1</sup>.

The manure fertilization determined changes in canopy swart level: an increase of Poaceae and a decrease of the Phabaceae and other botanic families by the systems' intensification

The meadows' floristic diversity reduced during the system's intensification by the disappearance of 90% of the species.

## References

- Păcurar F., (2005) Research regarding the sustainable development of Ghețari village, commune of Gârda by means of improvement of the natural grasslands and of some farming cultures, PhD thesis, USAMV Cluj-Napoca
- Reif A., Auch E., Bühler J., Katja Brinkmann, Goia I., Păcurar F. and Evelyn Rusdea, (2005) Landschaft und Landnutzung im Apuseni – Gebirge Rumäniens, Cathrina II, Klagenfurt, Germania, pp 161-201.
- Rotar I., Păcurar F. and Roxana Vidican, (2006) The influence of organic fertilisers on the biodiversity of a *Festuca rubra* meadow, *Grassland Science in Europe*, volume 11, EGF 2006, Badajoz, Spania, 110-112

# Production, quality and soil parameters in seminatural grassland at different mineral and organic nutrition

Cunderlik J.<sup>1</sup>, Ondrasek L.<sup>1</sup>, Britanak N.<sup>1</sup> and Tomaskin J.<sup>2</sup>

<sup>1</sup>Slovak Agricultural Research Centre – Grassland and Mountain Agriculture Research  
Institute, Mladeznicka 36, 974 21 Banska Bystrica, Slovakia

<sup>2</sup>Department of Ecology and Environmental Education, Faculty of Natural Sciences, Matej  
Bel University, Tajovskeho 40, 974 01 Banska Bystrica, Slovakia

## Abstract

In a two-year research (2004 – 2005), effects of mineral and organic fertilisers on production, quality, botanical composition and also on biological and chemical properties of soil were studied in seminatural grassland. A field trial was established at *Radvan* site (altitude 480 m) with these fertiliser treatments (kg ha<sup>-1</sup>): 1 - control; 2 - P<sub>30</sub> + K<sub>60</sub>; 3 - N<sub>60</sub> + PK; 4 - N<sub>120</sub> + PK; 5 - manure (12 t ha<sup>-1</sup>); 6 - manure (24 t ha<sup>-1</sup>). Over the research period, the highest dry matter (DM) production (5.36 t ha<sup>-1</sup>) was found at N<sub>120</sub> + PK. Total DM production was higher by 0.96 t ha<sup>-1</sup> in 2004 than in 2005. In the first year, the manure application resulted in expansion of weeds dominated by *Elytrigia repens*. In the second year, the proportion of meadow species and legumes increased. In soil, the application of manure and N<sub>120</sub> + PK stimulated CO<sub>2</sub> production, total N mineralisation and nitrification. Effects of manure increased total C content in soil microbial biomass (MB-C), N<sub>t</sub> and Mg, also P content increased at the lower manure rate applied. Soil acidity decreased at the higher manure rate applied. The rate of P<sub>30</sub> + K<sub>60</sub> stimulated especially MB-C content.

Keywords: seminatural grassland, production, botanical composition, soil properties

## Introduction

The important role of grassland is the primary production of good quality forage for cattle and sheep using the local resources, especially at upland and mountain regions. A regularly repeated application of manure or other organic fertilisers is necessary to maintain the soil fertility (Krajcovic *et al.*, 1990). Effects of fertiliser application on microbial changes of C and N in soil in relation to the environment are still studied attentively (Kandeler *et al.*, 1993, Lovell and Jarvis, 1996). Therefore, our objective was to assess effects of the applied nutrients on CO<sub>2</sub> production, total N mineralisation, nitrification, microbial biomass content and basic agrochemical properties of soil.

## Materials and methods

Production, quality and botanical composition of a sward were investigated in seminatural grassland (SG) utilised by three cuts at *Radvan* site (near Banska Bystrica, altitude 460 m) over two research years (2004 – 2005). In 2003, a field trial was established by the method of blocks with these fertiliser treatments (kg ha<sup>-1</sup>): 1 - control; 2 - P<sub>30</sub> + K<sub>60</sub>; 3 - N<sub>60</sub> + PK; 4 - N<sub>120</sub> + PK; 5 - manure (12 t ha<sup>-1</sup>); 6 - manure (24 t ha<sup>-1</sup>). In the spring and autumn of research years at the 1<sup>st</sup>, 2<sup>nd</sup> and 3<sup>rd</sup> cuts, respectively, fresh soil samples were taken from the 0 – 100 mm layer and passed through a 2 mm sieve. At the natural soil moisture content, these parameters were measured: the so-called reactive production of CO<sub>2</sub>(R) in soil by gas chromatography; total mineralisation of nitrogen (TMN) and the rate of nitrification (NIT)

after 14-day anaerobic incubation at 25°C. Total C content in soil microbial biomass (MB-C) was determined by the rehydration method (Ruzek, 1992) in the autumn samples. During 2005, the following parameters were analysed at every sampling: pH, C<sub>ox</sub> content (Tjurin), N<sub>t</sub> (Kjeldahl), P, K, Ca and Mg (by Melich III).

## Results and discussion

The botanical composition of sward was determined before each of the cuts over the growing seasons of 2004 – 2005. In 2004, the proportion of grasses increased to 75% as a result of N fertiliser application. The application of P and K fertilisers increased the proportion of legumes to 40%. At the manure application treatments, the proportions of grasses were high (83%) and with expanded presence of *Elytrigia repens* (40%), but those of legumes and other herbs were low. In 2005 at the manure treatments, the botanical composition changed and the proportion of legumes and other herbs increased. Herbage yield and nutrient uptake (N, P, K, Na, Ca, and Mg) are given in Tables 1 and 2. The data on herbage yield and nutrient uptake were submitted to a multi-factor analysis of variance by the least significant difference (LSD) test at the 95% confidence level when 2 research years and 6 fertiliser treatments were the factors of variation.

Table 1. Herbage yield (t ha<sup>-1</sup>) and nutrient uptake (kg ha<sup>-1</sup>) over 2004 – 2005

Years	Yield	Nutrient uptake					
		N	P	K	Na	Ca	Mg
2004	4.81 b	87.88 a	13.40 a	89.44 b	1.07 a	36.76 b	13.73 a
2005	3.85 a	92.32 a	13.17 a	80.56 a	1.82 b	32.38 a	12.99 a
LSD 95 % *	0.357	6.362	0.233	6.316	0.083	2.724	0.985

\*Data of a column indicated by different characters are significantly different from each other.

Table 2. Herbage yield (t ha<sup>-1</sup>) and nutrient uptake (kg ha<sup>-1</sup>) at the fertiliser treatments

Fertiliser treatments	Yield	Nutrient uptake					
		N	P	K	Na	Ca	Mg
1	3.18 a	62.69 a	9.67 a	61.82 a	1.12 a	25.41 a	9.77 a
2	3.47 a	77.09 b	10.74 b	72.28 a	1.23 a	31.42 b	11.03 a
3	4.52 b	93.28 c	12.34 b	91.98 b	1.49 b	37.32 c	13.52 b
4	5.36 c	113.33 d	14.77 c	93.66 b	1.73 c	44.76 d	16.68 c
5	4.76 bc	98.06 c	16.28 c	93.53 b	1.41 b	34.18 bc	14.36 b
6	4.68 b	96.15 c	15.90 c	96.73 b	1.67 c	34.35 bc	14.78 b
LSD 95 % *	0.618	11.019	1.687	10.939	0.145	4.718	1.707

\*Data of a column indicated by different characters are significantly different from each other.

The herbage yield notably varied within the research years (Table 1). In 2004, the yield was 4.81 t ha<sup>-1</sup> but it significantly decreased to 3.85 t ha<sup>-1</sup> in 2005. The higher air temperature and more rainfall in July and August of 2004, respectively, had marked impact on the increase in herbage yield. The N, P and Mg nutrients were evenly taken up by herbage in both research years, but K and Ca uptake was significantly higher in 2004 than in 2005 and the uptake of Na was significantly higher in 2005. Marked effects of fertiliser treatments on variability of herbage yield and nutrient uptake were found (Table 2). The lowest yields were recorded at treatments 1 and 2 (3.18 and 3.47 t ha<sup>-1</sup>, respectively). Significantly higher yields were found at treatments 3, 5 and 6. The highest yield (5.36 t ha<sup>-1</sup>) was recorded at treatment 4. Similarly, the lowest nutrient uptake was found at treatments 1 and 2; it was significantly higher at treatments 3, 5 and 6 and the highest at treatment 4 (especially that of N, Na, Ca and Mg). The analyses of microbiological and chemical properties of soil are shown in Tables 3 and 4. The amount of released CO<sub>2</sub>(R) represents here a state of development and activity of soil micro-flora at the day of sampling as determined by the presence of easily decomposable



forms of organic substances and by the soil moisture content. Mean values (Table 3) showed positive effects of manure application on CO<sub>2</sub> (R) that was 12 – 15% higher than the control. The effects of nitrogen fertiliser were observed as late as in 2005, when CO<sub>2</sub>(R) at 120 kg N ha<sup>-1</sup> rate was 18% higher than that of the control. The mineral and organic fertilisers markedly stimulated TMN in soil (Table 3). With 120 kg N ha<sup>-1</sup> application rate, TMN was higher by 74% than that at the control. Increased TMN resulted from manure application, especially at 12 t ha<sup>-1</sup> rate. In 2004, mean TMN at this treatment was nearly threefold higher than that at the control and 90% higher than with 24 t ha<sup>-1</sup> of manure applied. A reason of poorer TMN process at the higher rate of manure could be in too much organic matter supplied to soil and in deteriorated aeration conditions for soil micro-flora. In the second year after manure application, TMN remained stimulated, but much less than in 2004. The nitrification is a part of microbial changes of N in soil, however, it is a process determined not only by an appropriate moisture content and temperature, but also very much by sufficient aeration and pH of soil. The assessment of data on NIT (Table 3) is very similar to that relating to TMN. Consequently, the activity of nitrification bacteria was not limited by low pH, but mainly by sufficient amount of ammonia in the soil environment. In 2005, NIT significantly increased also in soil with P and K fertilisers application. The stimulation of N mineralisation resulting from organic fertilising is often assessed in relation to possible leaching of mineral forms of nitrogen (Kandeler *et al.*, 1993).

Table 3 Microbiological analysis of soil – mean data

Treatments	CO <sub>2</sub> (R)		TMN		NIT		MB-C	
	2004	2005	2004	2005	2004	2005	2004	2005
Control	129.4ab	130.0ab	9.0a	12.5ab	9.6a	14.3a	1838.9c	1964.7a
P 30 + K 60	146.2ab	144.4bc	11.2ab	16.4bc	11.4ab	17.5b	1535.8a	2219.0d
N 60 + P 30 + K 60	120.1a	129.2a	13.1abc	12.2a	14.9bc	13.9a	1597.4ab	2075.1ab
N 120 + P 30 + K 60	136.0ab	153.9c	15.6bc	21.6d	16.0cd	20.7c	1700.2ab	1957.0a
N 60 (manure)	147.4b	149.4c	26.3d	19.7cd	23.7e	20.8c	1741.3bc	2183.0bc
N 120 (manure)	148.3b	146.0c	18.1c	18.6cd	19.8de	20.3bc	1597.4ab	2157.3bc

Data of a column indicated by different characters are significantly different from each other. (LSD test, P = 95 %)

CO<sub>2</sub>(R) - so-called reactive production of CO<sub>2</sub> in soil after 1day of pre-incubation (mg CO<sub>2</sub> kg<sup>-1</sup>day<sup>-1</sup>)

TMN – total mineralisation of nitrogen in soil (mg NH<sub>4</sub>-N kg<sup>-1</sup>14 days<sup>-1</sup>)

NIT – the rate of nitrification in soil (mg NO<sub>3</sub>-N kg<sup>-1</sup>14 days<sup>-1</sup>)

MB-C – the carbon content of total microbial biomass in soil (mg C kg<sup>-1</sup>)

Table 4. Agrochemical analysis of soil – means of the growing season 2005

Treatments	Cox	Nt	HA : FA	pH	P	K	Mg
Control	28.6ab	2.6a	0.43a	3.91a	34.0b	99.8a	229.5a
P 30 + K 60	29.4b	2.8ab	0.43a	3.98a	17.1a	105.3a	312.7bc
N 60+ P 30 + K 60	26.2a	2.5a	0.43a	4.01ab	10.8a	102.9a	297.6b
N 120 + P 30 + K 60	27.4ab	2.6a	0.46a	4.16b	14.7a	99.2a	277.7b
N 60 (manure)	28.5ab	3.1b	0.45a	4.02ab	110.2c	103.8a	334.6c
N 120 (manure)	28.3ab	3.0b	0.46a	4.34c	23.4ab	99.9a	336.5c

Data of a column indicated by different characters are significantly different from each other. (LSD test, P = 95 %)

Cox, Nt as g kg<sup>-1</sup>

P, K, Mg as mg kg<sup>-1</sup>

During both the research years, a very low NO<sub>3</sub>-N level (about 5 mg kg<sup>-1</sup>) was recorded in soil at the trials. Positive effects of fertiliser application (manure especially) on MB-C content in soil were recorded as late as in 2005 (Table 3), excepting the inorganic fertiliser rate of 120

kg N ha<sup>-1</sup> which showed slightly inhibitory effects. The most noticeable increase in MB-C content was found in soil with P and K fertilisers addition. The most marked changes in agrochemical properties of soil resulted from manure application, namely soil acidity was lower and the content of N<sub>t</sub>, Mg and P increased. The increase in N<sub>t</sub> as well as a tendency to improvement in the humic acids to fulvic acids ratio (HA : FA) indicated starting qualitative and quantitative changes in soil organic matter.

## Conclusions

After two-year application of fertilisers and manure, the research showed that the higher rates of fertiliser N increased the proportion of grasses in sward. Manure application resulted in weed expansion, mostly *Elytrigia repens*, in 2004, but in the second year the proportion of grasses – including *E. repens* – decreased and that of legumes and other herbs increased. The effects of research years and fertiliser treatments on yield variability as well as on nutrient uptake by above-ground biomass were statistically significant. Herbage yield was 4.81 t ha<sup>-1</sup> in 2004. In 2005, the yield significantly decreased by 0.96 t ha<sup>-1</sup> to 3.85 t ha<sup>-1</sup>. The lowest herbage yield was recorded at the control and at P<sub>30</sub> + K<sub>60</sub> treatments (3.18 and 3.47 t ha<sup>-1</sup>, respectively). The significantly highest herbage yields were found at the treatments with manure and with the higher rates of fertiliser N application and a similar tendency was observed at the nutrient uptake results. The application of fertiliser and especially that of manure increased CO<sub>2</sub> production, total N mineralisation and nitrification. The organic fertiliser application mitigated the acidity of soil and increased N<sub>t</sub>, Mg and P content. The application of P and K fertilisers increased mainly the microbial biomass content in soil.

## References

- Kandeler E., Eder G. and Sobotik M. (1994) Microbial biomass, N mineralisation, and the activities of various enzymes in relation to nitrate leaching and root distribution in a slurry-amended grassland. *Biology and Fertility of Soils*. 18, 1, 7-12.
- Lovell R. D. and Jarvis S. C. (1996) Effect of cattle dung on soil microbial biomass C and N in a permanent pasture. *Soil Biol. Biochem.* (28), 291-299.
- Krajčovič V. *et al.* (1990) Komplexné využitie trávnych porastov v ČSFR. Syntetická záverečná správa, VÚLP, Banská Bystrica.
- RŮŽEK L. (1992) C-biomasy půdních mikroorganismů stanovený rehydratační metodou v orníční vrstvě půd. In *Metody stanovení mikrobiální biomasy v půdě: sborník referátů ze semináře, 2.-3. 6.1992, ÚPB ČSAV, České Budějovice*, ed: Šantrůčková, H., 1992, 18-26.

# **Comparable study of the nutritive value in Greek populations of *Dactylis glomerata* L. growing in contrasting environments in association to maturity**

Parissi Z.M., Avraam E.M., Karameri E., Kexagia A. and Karatassiou M.

*Aristotle University of Thessaloniki, School of Forestry and Natural Environment, Laboratory of Range Science, P.O Box 236, 541 24 Thessaloniki, Greece*

## **Abstract**

Greek populations of *Dactylis glomerata* L. from different bioclimatic zones were studied under the same climatic conditions, in order to investigate their heading date, their nutritive value in two phenological stages and their correlation. Two populations were from north, two from central and one from south Greece (Crete island). The chemical composition was determined in the vegetative stage and after the spikelets fully emerged for all populations. According to the results, the inflorescence emergence (first spikelet visible) occurred in population from south about a week earlier than in populations from central and north. Additionally, the population from south had lower nutritive value than the other populations in vegetative stage. The nutritive value decreased from vegetative to heading stage for all populations but the decrease was faster for the earliest maturing population from the north.

Keywords: heading date, phenological stage, forage quality

## **Introduction**

The nutritive value of temperate perennial grasses declines with increasing maturity during spring growth (Collins and Casler, 1990). This can be attributed to a decrease in crude protein concentration (Buxton and Marten, 1989) and an increase in fiber and lignin concentration (Belanger and McQueen, 1996).

*Dactylis glomerata* L. (D.gl) is a widespread perennial grass which exhibits a wide range of maturities because of genetic variation within and among its populations. Generally, early maturing genotypes are less digestible than late when harvested on a common date (Lentz and Buxton, 1991). The maturity and development stage of grasses depend on genotype (Moore and Moore, 1995), but also is a response of the plant to the growing environment (Nelson, 2000). The knowledge about the maturity of D.gl's populations from contrasting environments and its effect to the nutritive value is essential for effective management and genetic improvement.

The objective of this study was to compare five Greek populations of D.gl from different bioclimatic zones for maturity and nutritive value at the vegetative and heading phenological stages.

## **Materials and methods**

Vegetative tillers from 40 randomly selected individual plants of D.gl were collected at five different sites of Greece (Table 1), on summer-autumn of 2002. Approximately eight single tillers of each plant were initially planted into plastic pots, filled with organic matter. The pots were placed in a greenhouse for 2 months. Plants of each population were transplanted to the

field in spring 2003 in eight row plots, 45 by 100 cm (60 plants). Plots were arranged in a randomized complete-block design with four replications.

Table 1. Location, elevation, vegetation and climatic characteristics of the five collection sites in Greece.

Region	Libadi (Central)	Pertouli (Central)	Taxiarchis (North)	Chrysopigi (North)	Krete-Mount Ida (South)
Altitude (m)	1200	1100-1700	650-900	600	1100-1300
Aver. Max temperature (°C)	25	13	15	22	29
Aver. Min. temperature (°C)	-2 to -3	3	5	5	6
Av. Annual precipitation (mm)	900	1300	800	650	800
Vegetation classification	Fagetalia	Vaccinio-Picetalia - Astragalo- Acantholimonetalia	Quercetalia pubescentis - Fagetalia	Quercetalia pubescentis	Quercetalia pubescentis - Quercetalia ilicis

The heading date was measured as number of days after 1<sup>st</sup> of April for the appearance of the first spikelets from the uppermost leaf sheath (Moore *et al.*, 1991). For the nutritive value analysis, two samples of each plot were collected by randomly cutting tillers at 5 cm height above the ground at vegetative and heading stage of development. The samples were oven dried at 60 °C and ground through a 1 mm sieve mill. The ground samples were analyzed for N using a Kjeldahl procedure (AOAC, 1990) to determine crude protein (CP), neutral detergent fiber (NDF), acid detergent fiber (ADF) and acid detergent lignin (ADL) according to Van Soest *et al.* (1991). General linear models procedure (SPSS 14 for Windows) was used for ANOVA. The LSD at the 0.05 probability level was used to detect the differences among means (Steel and Torrie, 1980).

## Results and discussion

The inflorescence (first spikelet visible) emerged first in the Crete population from the south and in Chrysopigi (Table 2), which is from the north, but also is from the lowest elevation compared to all the other populations (Table 1). On the other hand, the latest population in inflorescence appearance was Pertouli, which is the population from the highest elevation (Table 1, 2).

There were significant differences among the populations (Table 2) for all the components of nutritive value analysis for both the vegetative and heading stage of development. In particular, Crete had lower CP and higher NDF and ADL concentration than all the other populations during the vegetative stage and this suggests a lower nutritive value. The CP concentration decreased and NDF, ADF and ADL concentration increased (Table 2) for all the populations during the heading stage. The decrease of CP was higher for Chrysopigi and the populations from central Greece. Moreover, the increase of ADF and ADL was higher for Chrysopigi and NDF was higher for Crete.

Table 2. Populations means of heading date (HD), CP, NDF, ADF and ADL (%) during the vegetative (VS) and heading (HS) stage of development.

Population	HD	CP (%)		NDF (%)		ADF (%)		ADL (%)	
		VS	HS	VS	HS	VS	HS	VS	HS
Chrysopigi	20 a*	23 bc	8 a	63 b	74 b	26 a	44 c	3 a	6 b
Taxiarchis	28 bc	22 ab	11 c	61 a	73 ab	25 a	39 a	3 a	4 a
Livadi	26 b	23 bc	9 ab	62 ab	73 ab	26 a	39 a	3 a	4 a
Pertouli	35 c	24 c	9 ab	62 ab	72 a	27 b	41 b	3 a	4 a
Crete	15 a	21 a	10 bc	67 c	76 c	26 a	41 b	4 b	6 b

\*Columns with different code letter are significantly different ( $P < 0.05$ )

According to the data, Crete had the lowest nutritive value during the vegetative stage. However, the nutritive value of all the other populations during the vegetative stage was more or less similar independently of their differences in heading date. The nutritive value decrease for all the populations during the heading stage, but faster for Chrysopigi, which is the earliest maturing population from North. It seems that generally Crete population has a lower nutritive value than the others and this is not due to early maturing.

In *Dactylis*, the diploid ( $2n=14$ ) and tetraploid ( $2n=28$ ) cytotypes were classified into either two groups of subspecies, namely Mediterranean and Eurasian groups, according to morphogeographical criteria, or into three groups, namely Subtropical, Mediterranean and Temperate groups, according to climate (Lumaret, 1988). According to the morphological study (unpublished data), it seems that the populations from north and central Greece belong to Eurasian group and those from the south to the Mediterranean group. The morphological trend in the Mediterranean group is towards a general reduction in plant size, small narrow leaves, many tillers and short ovate panicles. Additionally, the population from Mount Ida (Crete) differs from all other *Dactylis* in the extreme stiffness of the lower half of the culms (Borril, 1966). Therefore, the lower nutritive value of this population even in vegetative stage may be attributed to these morphological characteristics.

It can be concluded that the nutritive value of *D.gl*'s populations is more related with the particular morphological characteristics of the taxonomy group, than to the time of maturity. However, among the populations of the same group it seems that maturity affect the nutritive value and the early maturing populations have a lower nutritive value than the late ones, especially during the heading stage. The existing variation in nutritive value among the populations from north and central Greece could be used for the production of improved varieties. Concerning the management, keeping these populations in vegetative stage by grazing or cutting could be produce forage of a high nutritive value for a longer period during spring growth. The population from Crete is an endemic one, is well adaptive to the specific bioclimatic conditions of Mount Ida and because of this it is important for the forage production of this area.

## Conclusions

The nutritive value of *D.gl*'s populations from different taxonomy group according to morphogeographical criteria is more related with the particular morphological characteristics of the group, than to the time of maturity. Among the population of the same taxonomy group the maturity affect the nutritive value and the early maturing populations have a lower nutritive value than the late ones, especially during the heading stage.

## References

- AOAC (1990) Official Method of Analysis, 15<sup>th</sup> ed. Association of Official Analytical Chemists. Washington, DC, USA. p. 746.
- Belanger G. and McQueen R.E. (1996) Leaf and stem nutritive value of timothy cultivars differing in maturity. *Can. J. Plant. Sci.* 77, 237-245.
- Borril M. (1966) A morphological and genetical study of population differentiation in Cretan *Dactylis*. *J. Linn.Soc. (Bot.)*. 58, 87-93.
- Buxton D.R. and Marten G.C. (1989) Forage quality of plant parts of perennial grasses and relationship to phenology. *Crop Sci.* 29, 429-435.
- Collins M. and Casler M.D. (1990) Forage quality of five cool-season grasses. II. Species effects. *Animal Feed Science and Technology*. 27, 209-218.
- Lentz E.M. and Buxton D.R. (1991) Morphological trait and maturity relations with digestibility of orchardgrass. *Crop Sci.* 31, 1555-1560.
- Lumaret R. (1988) Cytology, genetics and evolution in the genus *Dactylis*. *C.R.C.Crit.Rev.Plant Sci.* 7, 55-91.
- Moore K.J., Moser L.E., Vogel K.P., Walter S.S., Johnson B.E. and Pedersen J.F. (1991) Describing and quantifying growth stages of perennial forage grasses. *Agronomy Journal*. 83, 1073-1077.
- Moore K.J. and Moore L.E. (1995) Quantifying developmental morphology of perennial grasses. *Crop Sci.* 35, 37-43.
- Nelson C.J. (2000) Shoot morphological plasticity of Grasses: Leaf growth vs. tillering. *Grassland Ecophysiology and Grazing Ecology*. (Lemaire G., Hodgson J., De Moraes A., Nabinger C. and De F.Carvalho P.C. eds). CABI Publishing.
- Steel, R.G.D., and J.H.Torrie. (1980) Principles and Procedures of Statistics. 2<sup>nd</sup> edn. McGraw-Hill, New York. pp 481.
- Van Soest P.J., Robertson J.B. and Lewis B.A. (1991) Methods for Dietary Fiber, Neutral Detergent Fiber and Non-starch Polysaccharides in Relation to Animal Nutrition. *J. Dairy Sci.* 74, 3583-3597.

# **Milk urea content as influenced by geographical area and season in Wallonia**

Meura S., DufRASne I., Cabaraux J.-F., Istasse L. and Hornick J.-L.

*Nutrition Unit, University of Liege, Boulevard de Colonster, 4000 Liège Belgium*

## **Abstract**

Milk urea concentration is routinely determined in commercial dairy farms along with the official milk analyses carried out on milk samples for the dairies by the “Comité du lait”. The milk urea content do not modify milk price but can be useful for the farmers for diet calculation, milk urea content being related to the energy-protein ratio in the diet. The aim of this paper was to study the evolution of the milk urea content according to the months and the areas. Milk urea concentration changed according to the months owing to the diet: the summer diets, mainly composed by grass in many farms, were characterized by higher nitrogen content which as result an increase in milk urea concentration. The geographic areas can also influence milk urea concentration due to dietary difference. For example, in the Hesbaye area, beet and cereals are produced while in the Ardennes, grasslands are dominant. The urea content in milk can be an useful measurement for the diet calculations in order to decrease nitrogen waste and to reduce the feed costs.

Keywords: milk urea, Wallonia, month, diet, area

## **Introduction**

Environment, nitrogen losses, pollution are acute problems for the world population; scientists of many countries are involved to estimate cows nitrogen losses. They aim to decrease these losses. Accurate estimates of nitrogen excretion are needed to plan manure storage facilities and to manage the use of such nutrient. Urea is a protein degradation waste which is related to nitrogen intake. Milk urea content in Belgium is easily and routinely estimated in tank milk. Urea content in milk bulk is a useful tool for assessing the equilibration of the diet for grazing dairy cows (Geerts *et al.*, 2004). A good knowledge of urea concentration in milk can be useful in the management of dairy cows. This study aims to evaluate the influence of the geographical area and season on milk urea content in Wallonia, the Southern part of Belgium.

## **Materials and methods**

Milk samples analysed by “Comité du lait” on tank samples obtained when the milk was transferred from the farms to the dairies were used. Fat and protein concentration were determined by infrared method (Milkoscan FT 6000<sup>®</sup> – Foss Denmark). Infrared technique was also used to determine milk urea. The survey was carried in 2005. On average there were 12 samples per month and per milk producer, so for Wallonia, there were 563862 data. The software SAS was used for the statistical analysis. Fat concentration, protein concentration, month, agricultural area, area-month interaction (“Ardennes”, “Condroz”, “Fagne”, “Famenne”, “Haute-Ardennes”, “Herbagère”, “Jurassique”, “Limoneux” and “Sablo-limoneux”) were the variables used in the model.

## Results and discussion

The data distribution was quite equal according to months although there were less data in February owing to the shorter duration in this month. There were 85% of data in 5 of the 9 areas (“Haute-Ardennes”, “Herbagère”, “Ardennes”, “Condroz” and “Limoneux”). There were 10% of data for “Famenne” and “Limoneux” and 2% for “Jurassique” and “Fagne”.

There were significant effects for each variable ( $P < 0.001$ ), and the model explained 31% of the variation. The part of the variation for each variable was 42%, 29%, 20%, 8%, and 1% for area, area-month interaction, protein concentration, month and fat concentration respectively.

Months explained 8% of the variation of the milk urea content. The average year milk urea content was  $246 \text{ mg l}^{-1}$  with a maximum in August ( $316 \text{ mg l}^{-1}$ ) and a minimum in December ( $178 \text{ mg l}^{-1}$ ) (Figure 1). Urea content showed large seasonal variations in 2005. From November to March urea content was lower than during the 3 next months, the April to June period during which urea content increased. In July, August, September, and October, urea content was the highest of the year.

The overall low urea content evolution from November to March can be related to the indoor management of the cows. On the basis of the grazing period from April to October, one has to note that the urea content was intermediate in April, May, June, and then rose to high levels up to October. Indoor period and grazing period were different in terms of ration. During grazing period, dairy cows were generally grazing in most of the farms, so that, their diet was mainly constituted by grass. By contrast, during the winter period indoor, the diet is generally more diversified and balanced. Grass contains a large excess of protein compared to energy. According to Olmos Colmenero and Broderich (2006), when proteins are in excess, there is an increased nitrogen recycling by ruminal wall and saliva, and an increased blood urea content, followed by an increased milk urea content. So the large milk urea concentration during the grazing season can be related to high nitrogen intake from grass. The subsequent decrease in milk urea content during the indoor period could be related to a more balanced diet in winter (Marini and Van Amburgh, 2003).

During the grazing period, average milk urea content in April, May, and June at  $241 \text{ mg kg}^{-1}$  was lower than in July, August and September ( $311 \text{ mg kg}^{-1}$ ). The diet was still based on grass. Probably, the changes in the chemical composition of grass can explain milk urea concentration increase. The main grass composition changes were an increase in nitrogen content and a decrease in water soluble carbohydrates content during the grazing season as observed over a 10 years study in Liege by Dufrasne (unpublished results). Such changes in chemical composition can lead to a greater imbalance of the diet at the end of the grazing season which as result higher milk urea contents during this period.

Geographical agricultural areas effects were significant, 40% of the urea content variation being explained by this parameter (Figure 2). The lowest milk urea contents were found in “Sablo-limoneux”, and in “Limoneux” areas ( $213$  and  $218 \text{ mg l}^{-1}$ ), and the highest in “Ardennes”, “Herbagère” and “Haute-Ardennes” areas ( $264$ ,  $268$ ,  $276 \text{ mg l}^{-1}$ ). “Jurassique”, “Famenne”, “Condroz”, and “Fagne” showed intermediate concentrations ( $234$ ,  $242$ ,  $245$ , and  $259 \text{ mg l}^{-1}$  respectively). There are major differences in agricultural practices in these areas. “Limoneux” and “Sablo-limoneux” are characterized by crops like cereals and beets while in the “Ardennes”, “Herbagère” and “Haute-Ardennes” areas grass is the main crop.



Interaction between areas and months explained 29% of the variation in concentration of milk urea content ( $P < 0.05$ ). In each area, milk urea content increased sharply from March to July. The pattern of milk urea content overtime in the “Ardennes” was quite different compared to “Haute-Ardennes” and “Herbagère”, the highest milk urea content being observed during the grazing period and intermediate milk urea content during indoor period. In the “Ardennes” no supplement is offered to cows when they grazed while during the indoor period, the cows are offered mainly hay and grass silage of roller with a poor quality owing to a late harvest. The management in the “Ardennes” can be considered as extensive as compared to the management in “Herbagère” and “Haute-Ardennes” areas where pastures are intensively managed with 4 grass cuts per year and supplemental feed distributed during the grazing season.

## Conclusions

Agricultural areas and months influenced significantly tank milk urea contents. Nitrogen intake can explain the differences observed in the agricultural areas and during the year. Other diet components, like carbohydrate fractions, could also influence milk urea content. More research is needed to study the effect of diet components. It would be interesting to study the effect of agricultural area and month on milk urea content during several years to confirm these results. Such research can be useful for dietary formulation in order to decrease nitrogen waste.

## References

- Geerts N.E., De Brabander D.L., Vanacker J.M., De Boever J.L. and Botterman S.M. (2004) Milk urea concentration as affected by complete diet feeding and protein balance in the rumen of dairy cattle. *Livestock Production Science*, 85, 263–273
- Marini J. C. and Van Amburgh M. E. (2003) Nitrogen metabolism and recycling in Holstein heifers, *Journal of dairy sciences*, 81, 545–552
- Olmos Colmenero J. J. and Broderick G. A. (2006) Effect of dietary crude protein concentration on ruminal nitrogen metabolism in lactating dairy cows. *Journal of Dairy Sciences*, 89, 1694–1703.

# Changes in botanical composition of permanent and temporary grasslands

Britanak N., Ilavska I., Hanzes L. and Liptak L.

*Slovak Agricultural Research Centre – Grassland and Mountain Agriculture Research Institute, Research Station, ul. SNP 2, 058 01 Poprad, Slovakia*

## Abstract

A field trial was established in a mountain region of Slovakia in 1992. Penetration of the original species to temporary grassland and also sward productivity were studied. A part of permanent grassland (*Festuco-Cynosuretum* association) utilised by cutting was ploughed and sown with a grass/clover mixture (*Festulolium* 41%, *Dactylis glomerata* 28%, *Lolium perenne* 14%, *Trifolium pratense* 10% and *Trifolium repens* 7%) in the spring. In 1992, botanical composition comprised 32 vascular plant species. Four nutrition levels were applied to both temporary and permanent sward (1. N<sub>0</sub>P<sub>0</sub>K<sub>0</sub>; 2. N<sub>0</sub>P<sub>30</sub>K<sub>60</sub>; 3. N<sub>90</sub>P<sub>30</sub>K<sub>60</sub> and 4. N<sub>180</sub>P<sub>30</sub>K<sub>60</sub>). Between 1993 and 2002, the botanical composition was determined always before the 1st cut and consequently, these parameters were calculated: Shannon-Wiener Index (H'); evenness (J'); number of equally common species (N<sub>1</sub>) for the diversity (H'); index of qualitative similarity (IS<sub>J</sub>) and index of quantitative similarity (IS<sub>J/G</sub>). After 10 research years, the quality was – surprisingly - the most similar to the original sward at the N<sub>90</sub>P<sub>30</sub>K<sub>60</sub> treatments at both the permanent and the temporary grassland. By comparison to 1992, the closest quantitative similarity was found at the permanent grassland treatments 2 and 3 and at the temporary sward treatment 2. In both the grassland types, the other research parameters were better than the initial ones at the 1<sup>st</sup> and the 2<sup>nd</sup> treatments but worse at the treatments with nitrogen application.

Keywords: permanent grassland, temporary grassland, botanical composition

## Introduction

Biodiversity is a multifaceted phenomenon involving the variety of organisms present, the genetic differences among them, and the communities, ecosystems, and landscape patterns in which they occur. Community diversity, also sometimes known as intra-stand or *alpha* diversity, deals with the members of taxa and their relative abundance within a stand. The usual compound expressions of community biodiversity really involve two fundamental features: (1) richness, also sometimes known as variety species density; and (2) relative abundance of component taxa, also called equitability or evenness (West, 1993). One of the principal benefits ascribed to increased plant diversity in grassland systems has been increased primary productivity (Sanderson, 2005). This paper presents a research on changes in botanical composition of permanent (PG) and temporary (TG) grasslands at Liptovska Teplicka, a mountain village in northern Slovakia. The village was founded by the Gorals, an ethnic group coming from Kysuce, another one of the north-Slovakian mountain regions, in 1634. The human colonisation of the area resulted in deforestation and created conditions for some non-forest communities, mainly meadows and pastures (Ruzickova *et al.*, 1999).

## Materials and methods

Initially, the examined site (altitude 960 m) had been arable land that naturally turned to grassland later and created plant community association of *Festuco-Cynosuretum*. In the spring of 1992, a part of permanent grassland utilised by cutting was ploughed and sown with grass/clover mixture at 29 kg ha<sup>-1</sup> sowing rate (*Festulolium* cv. Felina 41%, *Dactylis glomerata* cv. Relat 28%, *Lolium perenne* cv. Metropol 14%, *Trifolium pratense* cv. Sigord 10% and *Trifolium repens* cv. Huia 7%). Four nutrition levels were applied to both temporary and permanent swards at the following fertiliser rates: Treatment 1 - N<sub>0</sub>P<sub>0</sub>K<sub>0</sub>; Treatment 2 - N<sub>0</sub>P<sub>30</sub>K<sub>60</sub>; Treatment 3 - N<sub>90</sub>P<sub>30</sub>K<sub>60</sub> and Treatment 4 - N<sub>180</sub>P<sub>30</sub>K<sub>60</sub>. Between 1993 and 2002, botanical composition was determined always before the 1<sup>st</sup> cut by Gaborcik and Javorkova (1980). Consequently, Shannon-Wiener Index (H'); evenness (J'); number of equally common species (N<sub>1</sub>) for the diversity (H'); index of qualitative similarity (IS<sub>J</sub>) and index of quantitative similarity (IS<sub>J/G</sub>) were calculated for each plot as follows: Shannon-Wiener Index  $H' = -\sum (P_i \times \ln P_i)$ ; Evenness  $J = \frac{H'}{\ln S}$ ; Number of equally common species  $N_1 = 2^{H'}$ . Index of

qualitative similarity  $IS_J = \frac{c}{A + B - c}$ ; and Index of quantitative similarity  $IS_{J/G} = \frac{\sum c_i}{a_i + b_i - c_i}$

where P<sub>i</sub> is the proportion of the i<sup>th</sup> species; S is number of species; A is number of species in A plot; B is number of species in B plot; c is number of common species in A and B plots; c<sub>i</sub> is abundance of i<sup>th</sup> species in compared plots; a<sub>i</sub> is abundance of species present in A plot only; b<sub>i</sub> is abundance of species present in B plot only (Begon *et al.*, 2002; Moravec, 2000). The composition of permanent grassland was initially as follows: H' = 2.48; J' = 0.72; N<sub>1</sub> = 5.58; and S = 32. The file normality was tested where H' and J' parameters were submitted to a square root transformation, but the data presented here are given without the transformation. Total dry matter (DM) yield was determined at three cuts in four randomised replicates with plot dimensions 3m x 8 m over the growing season.

## Results and discussion

After 10 research years, the qualitative similarity was – surprisingly - the most comparable with that of the original swards at Treatments 3 in PG and TG, respectively. This qualitative similarity probably resulted from depleted nutrients in soils of the originally mesophilous meadows (Treatment 1). Another reason was the suppression of mesophilous species (Treatments 2 and 4) and subsequent expansion of other species requiring high nutrient rates, i. e. P, K and N. By comparison to 1992, the closest quantitative similarity was found at PG Treatments 2 and 3 and at TG Treatment 2 (Table 1).

Table 1. A comparison of changes in qualitative and quantitative similarities (β diversity) ten years after the year 1992 when permanent grassland comprised 32 vascular plant species

Similarity	PG 1	PG 2	PG 3	PG 4	TG 1	TG 2	TG 3	TG 4
IS <sub>J</sub>	52	51	59	53	37	37	41	30
IS <sub>J/G</sub>	90	95	94	75	73	76	68	43
Yield	1.88	3.24	4.99	6.31	2.67	3.99	5.64	7.35
LSD <sub>0.05</sub> PG = 2.01 and TG = 2.23								
LSD <sub>0.01</sub> PG = 2.69 and TG = 2.98								

Notes: PG – permanent grassland; TG – temporary grassland; from 1 to 4 – fertiliser treatments

More nutrients supplied by the fertilisers resulted in the lowest qualitative similarity at Treatments 4 in PG and TG, respectively. After 10 years, the abundance of common species (that penetrated the sward or were sown in the grass/clover mixture) ranged from 68 to 76% at Treatments 1, 2 and 3. In temporary sward, this succession is favourable from the environmental point of view, but not from the economic aspect.

Table 2 shows the development of indices and their average values at PG and TG.

Table 2. The investigated parameters - means of the research years

Years	Treatments	H'		J'		N <sub>1</sub>		S	
		PG	TG	PG	TG	PG	TG	PG	TG
1993	1	2.67	2.02	0.81	0.64	6.38	4.05	27	23
	2	2.48	2.10	0.76	0.74	5.56	4.30	26	17
	3	2.53	2.04	0.77	0.69	5.76	4.12	27	19
	4	2.45	1.91	0.74	0.68	5.46	3.77	27	17
1994	1	3.02	1.03 <sup>a</sup>	0.87	0.33 <sup>ab</sup>	8.13 <sup>a</sup>	2.05	32 <sup>a</sup>	23 <sup>a</sup>
	2	2.78	1.27 <sup>a</sup>	0.83	0.42 <sup>a</sup>	6.87 <sup>a</sup>	2.41	29 <sup>ab</sup>	20 <sup>ab</sup>
	3	2.62	0.89 <sup>a</sup>	0.79	0.34 <sup>ab</sup>	6.14 <sup>b</sup>	1.85	28 <sup>ab</sup>	14 <sup>bc</sup>
	4	2.55	0.25 <sup>b</sup>	0.80	0.10 <sup>b</sup>	5.86 <sup>b</sup>	1.19	24 <sup>b</sup>	11 <sup>c</sup>
1995	1	2.80	1.10	0.82 <sup>a</sup>	0.39	6.97 <sup>a</sup>	2.14	30	17 <sup>ab</sup>
	2	2.72	0.92	0.79 <sup>a</sup>	0.30	6.59 <sup>a</sup>	1.89	31	21 <sup>a</sup>
	3	2.46	0.94	0.78 <sup>ab</sup>	0.36	5.52 <sup>a</sup>	1.92	24	14 <sup>b</sup>
	4	2.29	1.19	0.70 <sup>b</sup>	0.44	4.90 <sup>b</sup>	2.28	26	15 <sup>ab</sup>
1996	1	3.09	1.90	0.88 <sup>a</sup>	0.70	8.51 <sup>a</sup>	3.72	33 <sup>a</sup>	15
	2	2.88	1.83	0.85 <sup>a</sup>	0.74	7.34 <sup>ab</sup>	3.55	30 <sup>ab</sup>	12
	3	2.76	1.34	0.84 <sup>ab</sup>	0.61	6.79 <sup>bc</sup>	2.54	27 <sup>ab</sup>	9
	4	2.43	1.26	0.75 <sup>b</sup>	0.53	5.38 <sup>c</sup>	2.40	25 <sup>b</sup>	11
1997	1	2.13	1.02	0.71 <sup>b</sup>	0.41 <sup>ab</sup>	4.37	2.03	20 <sup>a</sup>	12
	2	2.38	1.19	0.81 <sup>a</sup>	0.49 <sup>a</sup>	5.20	2.27	19 <sup>a</sup>	11
	3	2.07	0.47	0.81 <sup>a</sup>	0.22 <sup>b</sup>	4.21	1.38	13 <sup>ab</sup>	8
	4	1.82	0.37	0.76 <sup>ab</sup>	0.17 <sup>b</sup>	3.53	1.30	11 <sup>b</sup>	9
1998	1	2.82	2.71 <sup>a</sup>	0.88 <sup>a</sup>	0.88 <sup>a</sup>	7.08 <sup>a</sup>	6.54 <sup>a</sup>	25	22 <sup>a</sup>
	2	2.68	2.53 <sup>a</sup>	0.84 <sup>a</sup>	0.82 <sup>a</sup>	6.43 <sup>a</sup>	5.78 <sup>a</sup>	24	22 <sup>a</sup>
	3	2.07	1.44 <sup>b</sup>	0.68 <sup>b</sup>	0.51 <sup>b</sup>	4.20 <sup>b</sup>	2.71 <sup>b</sup>	21	17 <sup>ab</sup>
	4	1.60	1.34 <sup>b</sup>	0.54 <sup>b</sup>	0.50 <sup>b</sup>	3.03 <sup>b</sup>	2.54 <sup>b</sup>	19	15 <sup>b</sup>
1999	1	2.66	2.27 <sup>a</sup>	0.90 <sup>a</sup>	0.77 <sup>a</sup>	6.32 <sup>a</sup>	4.81 <sup>a</sup>	19	19 <sup>ab</sup>
	2	2.38	1.85 <sup>a</sup>	0.77 <sup>b</sup>	0.58 <sup>ab</sup>	5.21 <sup>ab</sup>	3.60 <sup>ab</sup>	22	24 <sup>a</sup>
	3	2.19	0.94 <sup>b</sup>	0.73 <sup>bc</sup>	0.34 <sup>bc</sup>	4.56 <sup>bc</sup>	1.92 <sup>bc</sup>	20	16 <sup>b</sup>
	4	1.79	0.65 <sup>b</sup>	0.65 <sup>c</sup>	0.25 <sup>c</sup>	3.46 <sup>c</sup>	1.57 <sup>c</sup>	16	14 <sup>b</sup>
2000	1	2.56	2.34 <sup>ab</sup>	0.79	0.76 <sup>a</sup>	5.91 <sup>a</sup>	5.06 <sup>a</sup>	26 <sup>a</sup>	22 <sup>a</sup>
	2	2.49	2.41 <sup>a</sup>	0.79	0.79 <sup>a</sup>	5.63 <sup>a</sup>	5.32 <sup>a</sup>	23 <sup>ab</sup>	21 <sup>ab</sup>
	3	2.15	1.55 <sup>bc</sup>	0.70	0.60 <sup>ab</sup>	4.45 <sup>ab</sup>	2.92 <sup>b</sup>	22 <sup>ab</sup>	13 <sup>c</sup>
	4	2.04	1.32 <sup>c</sup>	0.74	0.49 <sup>b</sup>	4.11 <sup>b</sup>	2.50 <sup>b</sup>	16 <sup>b</sup>	15 <sup>bc</sup>
2001	1	2.22	2.38 <sup>a</sup>	0.71 <sup>a</sup>	0.82 <sup>a</sup>	4.66 <sup>ab</sup>	5.22 <sup>a</sup>	23	18
	2	2.33	2.30 <sup>a</sup>	0.74 <sup>a</sup>	0.79 <sup>a</sup>	5.03 <sup>a</sup>	4.91 <sup>a</sup>	23	18
	3	2.13	1.51 <sup>b</sup>	0.70 <sup>a</sup>	0.53 <sup>b</sup>	4.37 <sup>ab</sup>	2.85 <sup>b</sup>	21	17
	4	1.74	1.39 <sup>b</sup>	0.55 <sup>b</sup>	0.49 <sup>b</sup>	3.34 <sup>b</sup>	2.63 <sup>b</sup>	23	17
2002	1	2.72	2.56 <sup>a</sup>	0.88 <sup>a</sup>	0.74	6.61 <sup>a</sup>	5.89 <sup>a</sup>	22	31 <sup>a</sup>
	2	2.50	2.40 <sup>a</sup>	0.80 <sup>ab</sup>	0.76	5.64 <sup>ab</sup>	5.28 <sup>a</sup>	23	24 <sup>b</sup>
	3	2.28	1.96 <sup>b</sup>	0.74 <sup>b</sup>	0.60	4.85 <sup>b</sup>	3.90 <sup>b</sup>	22	26 <sup>ab</sup>
	4	2.30	1.73 <sup>b</sup>	0.73 <sup>b</sup>	0.58	4.91 <sup>b</sup>	3.31 <sup>b</sup>	23	20 <sup>b</sup>

Considering the rate and composition of the sown grass/clover mixture, the indices were as follows:  $H' = 1.41$ ;  $J' = 0.88$ ;  $N_1 = 2.66$ ; and  $S = 5$ . The Shannon-Wiener Index was higher in the 1<sup>st</sup> research year (Table 2) than in the 2<sup>nd</sup> to 5<sup>th</sup> years as a result of increased evenness. This conclusion is supported also by higher numbers of the equally common species ( $N_1 = 3.77 - 4.30$ ). In the following years, all the indices decreased nearly by a half. However, all the parameters increased in the 6<sup>th</sup> harvest year (1998). It could have been caused by a decreased proportion of *Dactylis glomerata* in sward ( $D = 65 - 91\%$  in 1997 and  $15 - 50\%$  in 1998; data not presented here). This vacancy was filled and colonised by species from the original sward, such as *Poa pratensis*, *P. trivialis*, *Ranunculus acris*, *Alchemilla xanthochlora*, *Stellaria graminea* and *Veronica chamaedrys*. In 1999, after this increase, *D. glomerata* was dominant again (23 - 82%), but the proportions of other species that penetrated

into sward were not influenced very much. Later, the temporary grassland maintained its higher values. At TG, the species diversity and the evenness were influenced by fertiliser N ( $P < 0.05$ ). As shown in Tables 2 and 3, the fertiliser N application significantly decreased average values of the Shannon's index and the evenness ( $P < 0.05$ ). All the investigated parameters decreased with the application of fertilisers, but the effects of P and K were less negative at both TG and PG. However, other differences were not significant in the temporary grassland, except for the parameters mentioned earlier (Table 3).

Table 3. The investigated parameters averaged over 10 research years

Treatments	H'		J'		N <sub>1</sub>		S	
	PG	TG	PG	TG	PG	TG	PG	TG
1	2.67	1.93	0.83	0.67	6.49	4.15	25.70	20.20
2	2.56	1.88	0.80	0.64	5.95	3.93	25.00	19.00
3	2.33	1.31	0.75	0.48	5.08	2.61	22.50	15.30
4	2.10	1.14	0.70	0.42	4.40	2.35	21.00	14.40
LSD <sub>0.05</sub> Grassland	0.900		0.271		2.720		9.759	
LSD <sub>0.01</sub>	1.196		0.360		3.618		12.980	
LSD <sub>0.05</sub> Treatment	0.666		0.192		2.253		7.719	
LSD <sub>0.01</sub>	0.846		0.255		2.997		10.267	

The relationship between the fertiliser application and the type of grassland was not statistically significant. Imrichova (2005) also reported the increasing index of diversity and evenness related to the extensive utilisation of grassland. The effects of fertiliser application on DM yield were found (Table 1). The increased DM yield in TG resulted from the use of bred cultivars in sward. These eutrophic species are more productive in comparison with the native oligotrophic or even mesotrophic species from the original sward. Peeters and Janssens (1998) noted that considering reductions both in yield and quality, output can be estimated at 2/3 in comparison to highly fertilised grasslands. This opinion was confirmed also by mean yield at the treatments without fertiliser application, where the cultivars composed in the sown grass/clover mixture were one of the intensifying factors and the productivity of PG was at 70 % level in comparison to DM yield at TG. At permanent grassland, other percentage was 80%, 88% and 85% at Treatments 2, 3 and 4, respectively.

## Conclusions

The investigated parameters were better on permanent grassland. For both permanent and temporary grassland, these indices decreased with the rising intensity of fertilizer application. To the contrary DM production of both grasslands was increasing with higher nutrition level. Whether changes are desirable or not depends on who is paying the bills and benefiting from the consequences (West, 1993).

## References

- Gáborčík N. and Javorková A. (1980). Dynamics of growth phytocoenosis including fundamental processes. Final report. GMARI Banská Bystrica. 52 pp. (in Slovak).
- Imrichova Z. (2005). Biodiversity of grasslands in consequence of different intensity and way of land use, in: Novak J. *et al.* (eds). Tatra meadows. SUA Nitra, pp. 39-43 (in Slovak with English abstract).
- Moravec J. (2000). Phytocoenosis. Academia, Prague, 404 p. (in Czech).
- Peeters A. and Janssens, F. (1998). Species-rich grasslands: diagnostic, restoration and use in intensive livestock production systems. In: Nagy G. and Petö K. (eds). *Grassland Science in Europe*, 3: 375-393.
- Ruzickova H., Dobrovodská M. and Valachovic M. (1999): Landscape-ecological evaluation of vegetation in relation to the forms of anthropogenic relief in the cadastre of Liptovská Teplička Village, the Nízke Tatry Mts. *Ekológia* (Bratislava), 18, p. 381-400.
- West N.E. (1993) Biodiversity of rangelands. *Journal of Range Management*, 46, 1, 2-13

# Estimation of grassland management impact on biodiversity

Jeanneret Ph., Huguenin-Elie O., Baumgartner D., Freiermuth Knuchel R., Gaillard G., Nemecek Th. and Weibel P.

*Agroscope Reckenholz-Tänikon Research Station ART, Reckenholzstrasse 191, 8046 Zurich, Switzerland*

## Abstract

Agroscope Reckenholz-Tänikon Research Station ART developed a method for the integration of biodiversity (organismal diversity) as an impact category of Life Cycle Assessment (LCA) for agricultural production (SALCA-Biodiversity). This method is applied to grasslands and arable crops to estimate the impact of management systems on biodiversity. First, a list of indicator species groups (flora, birds, mammals, amphibians, snails, spiders, carabids, butterflies, wild bees, and grasshoppers) was established considering ecological and life cycle assessment criteria. Second, inventory data about agricultural practices with detailed management options were specified. Third, a scoring system estimated the reaction of every indicator species group regarding management options, followed by an aggregation step. In a case study, biodiversity scores for grassland management systems were calculated. Results show the dominant influence of management intensity on most indicators and the inflection point of management from which large impacts on biodiversity are to be expected.

Keywords: biodiversity, grassland management, impact estimation, life cycle assessment

## Introduction

Grassland management operations may greatly affect biodiversity and furthermore, influence basic ecological functions, i.e. organic matter decomposition, herbivory, predation and pollination at global scale. Therefore, assessing impacts of grassland management on biodiversity is an important issue.

Agroscope Reckenholz-Tänikon Research Station ART developed a method for the integration of biodiversity as an impact category into the Life Cycle Assessment (LCA) of farms (SALCA-Biodiversity, Jeanneret *et al.*, 2006). Two approaches for evaluating the effects of agricultural activities (in a broad sense) on biodiversity are found in the literature: (1) biodiversity is included as an impact category in LCA like other categories, e.g. the greenhouse effect. This approach is essentially based on the species diversity of vascular plants and includes the impact of industry, agriculture and transport on a continent scale (e.g. Lindeijer *et al.*, 1998). (2) An environmental diagnosis based on a biotope evaluation with indicators is done ("ecological value" of farms, e.g. Brosseau, 1999). Our method is based on the first approach but is more detailed and is designed for use in Switzerland and adjoining regions. The method aims at estimating and comparing the impact of agricultural management systems on biodiversity. As part of this project, impact assessment of grassland management practices on biodiversity is presented.

## Materials and methods

Since the whole biodiversity can neither be measured nor can the impact of management practices on biodiversity be entirely estimated, indicators have to be used. In the present method the choice of indicator species groups was made using a criteria Table based on the

linking of the species to agricultural activity, and general criteria such as the species distribution in the cultivated landscapes, their habitats and their place in the food chain (Jeanneret *et al.*, 2006). The set of indicators must also give as representative a picture as possible of organismal diversity as a whole. The following species groups were selected: flowering plants, birds, small mammals, amphibians, snails, spiders, carabid beetles, butterflies, wild bees and grasshoppers. Soil organisms were not considered in this study. Furthermore, we distinguished between the overall species diversity of each species group and the ecologically demanding species (stenotopic species, red list species) in the impact estimation.

The effect of the management activities on each indicator species group were estimated based on information from the literature and expert knowledge. All the typical grassland management activities such as manuring and mowing were specified with options, e.g. the type of fertiliser or the mowing period (restricted to the Swiss farming). The impact of each management option was rated on a scale of 0 to 5 (rating R, Table 2).

Table 2. Rating R of management option impact on the selected indicator species groups.

0:	The species group is unaffected because it does not occur in grasslands.
1:	The option leads to a severe impoverishment of species diversity within the species group considered and renders impossible the occurrence of stenotopic species and red list species.
2:	The option leads to a slight impoverishment of species diversity within the species group considered and renders impossible the occurrence of stenotopic species and red list species.
3:	The option has no direct effect on the species group considered.
4:	The option leads to a slight increase in species diversity within the species group considered and makes possible the occurrence of stenotopic species and red list species.
5:	The option promotes species diversity within the species group considered and makes possible the occurrence of stenotopic species and red list species.

Since grasslands and other habitats of the agricultural landscape represent various habitat suitability's, a coefficient ranging from 1 to 10 ( $C_{habitat}$ ) was attributed to weight the rating of the management options, for each indicator species group specifically. Similarly, a second coefficient from 0 to 10 ( $C_{management}$ ) quantified the relative importance of management activities for a given habitat, e.g. grazing and mowing in grasslands, for each indicator species group. The final score S of a management option was the product of the mean value of the two weighting coefficients  $C_{habitat}$  and  $C_{management}$ , and the rating of the management option R. In case of management activities repeated during the year (e.g. mowing) an annual average was calculated when the indicator species group can recover from one period to another, or the most negative period was considered in case of a permanent damage. The final score  $S_f$  (= biodiversity score) of a given grassland was calculated as the sum of the scores of the management activities divided by the number of activities. Comparison of management scenarios can then be made at field level first but as ratings and coefficients were also defined for crops and semi-natural habitats, biodiversity scores can also be calculated at farm level.

Realistic scenarios of grassland management systems for the Swiss lowlands were defined to test the impact on the indicator species groups (Table 3, Nemecek *et al.*, 2005). Scenarios showed a large intensity gradient ranging from one utilization and no fertilization (extensive grassland, net yield: 2.7 t DM ha<sup>-1</sup> and year) to five utilizations and fertilizer applications (intensive grassland, net yield: 11.1 t DM ha<sup>-1</sup> and year). Slurry and solid manure were integrated as two different fertilization forms. Scenarios for intensive, fairly intensive, low intensive and extensive grasslands did not include grazing. The extensive pasture scenario consisted of grazing only.

Table 3. Management intensity and production features of grasslands used to test the impact on indicator species groups. Underlined are management activities entering the estimation of impact on indicator species groups.

Grassland management	Net yield <sup>1</sup>	NEL-content <sup>2</sup>	<u>N. util.</u> <sup>3</sup>	kg N <sup>4</sup>	<u>N. fertil.</u> <sup>5</sup>	Fertilization form (% N available)		<u>Herbicide</u> <sup>6</sup>
						<u>Slurry</u>	<u>Solid manure</u>	
Intensive	11.1	5.8	5	146	5	100		0.5
Fairly intensive	9.0	5.2	4	99	4	100		0.5
Low intensive	5.6	4.8	3	33	1		100	0
Extensive	2.7	4.2	1	0				0
Extensive pasture	2.3	5.3	2	0				0

<sup>1</sup>t DM ha<sup>-1</sup> and year, <sup>2</sup>MJ kg<sup>-1</sup> DM, <sup>3</sup>number of utilization year<sup>-1</sup>, <sup>4</sup>kg N available ha<sup>-1</sup> and year, <sup>5</sup>number of fertilizer application year<sup>-1</sup>, <sup>6</sup>kg active ingredient/year

## Results and discussion

Calculated for the range of grassland types and indicator species groups, biodiversity scores definitely increase with decreasing management intensity for the overall species diversity (aggregated), for most of the indicator species groups and the ecologically demanding species (Table 4). Scores for ecologically demanding species are slightly lower than those of overall species diversity. An obvious inflection point occurs between fairly intensive and low intensive grasslands, i.e. between 4 to 3 cuts/year, a decreasing amount of quickly available N and a change of the manure form. Indeed, aggregated biodiversity scores increase by 0.2 from intensive to fairly intensive, by 7.4 from fairly intensive to low intensive. Nevertheless, scores increase by an additional 7.5 from low intensive to extensive grasslands showing the importance of extensive grasslands for biodiversity. Snails are an exception to this pattern, the largest difference taking place between low intensive and extensive grassland (93.9% increase). No fertilization at all is then more important than the fertilizer form for snails. Extensive grasslands obtain higher biodiversity scores than low intensive grasslands except for mammals which do not take advantage of one of both types. The largest difference in percentage between fairly intensive and low intensive grasslands occurs for the amphibian special life phase (aquatic life phase, 0.8 to 2.9, 257.8%). The reason is that fertilization with slurry may cause damages during the amphibian aquatic phase by streaming in water bodies. The highest scores are obtained by butterflies in extensive grasslands (36.0 for both features), followed by grasshoppers and wild bees. These high scores are mainly due to the high habitat coefficients attributed to grassland habitats reflecting their importance for all three indicator species groups in the agricultural landscape. In contrast, plants obtain slightly lower scores because non-grassland habitats in the cultivated landscapes may show higher plant diversity than grasslands, e.g. hedges. Overall, extensive pastures and extensive grasslands have similar scores. Nevertheless, while snails, spiders and carabid beetles show the same pattern as the other indicators regarding comparison of extensive and intensive grasslands, they are less positively influenced by the extensive pasture scenario. This suggests that these indicator species groups are more disturbed by cattle grazing than by mowing activities.



Table 4. Biodiversity scores  $S_f$  of indicator species groups obtained with the SALCA-Biodiversity method for five grassland management systems. Theoretical minimum score is 1 and maximum 50.

Grassland management	Intensive	Fairly intensive	Low intensive	Extensive	Extensive pasture
Overall species diversity					
Aggregated <sup>1</sup>	6.2	6.4	13.8	21.3	20.1
Plants	3.7	3.9	11.4	18.5	21.0
Birds	6.4	6.7	13.8	22.0	25.3
Mammals	7.3	7.3	11.1	11.1	10.8
Amphibians	2.1	2.1	5.2	9.5	11.8
Snails	5.4	5.6	5.8	11.3	6.4
Spiders	9.1	9.3	15.8	22.4	19.3
Carabid Beetles	7.0	7.4	13.6	21.0	14.8
Butterflies	6.8	7.0	20.0	36.0	35.8
Wild Bees	7.4	7.6	18.6	23.0	20.6
Grasshoppers	6.9	6.9	19.4	33.1	31.6
Ecologically demanding species and special life phase					
Amphibians	0.8	0.8	2.9	4.8	5.8
Spiders	8.9	9.0	15.3	21.6	17.8
Carabid Beetles	7.0	7.3	13.4	20.6	14.0
Butterflies	6.7	6.8	19.4	36.0	35.8
Grasshoppers	6.8	6.8	19.3	32.9	30.0

<sup>1</sup>Scores are aggregated taking into account rules of trophic relations between indicator species groups.

## Conclusion

For biodiversity at farm level, extensive grasslands all over the farm would be the best. Nevertheless, results suggest that a combination of intensive and extensive grasslands (e.g. 2/3-1/3, 3/4-1/4) to associate advantages for biodiversity with agricultural production would be more beneficial for biodiversity than fairly intensive grasslands all over the farm because the biodiversity potential of the extensive part in this combination model is much higher than the one of fairly intensive grasslands.

## References

- Brosson P. (1999) Le diagnostic agri-environnemental pour une agriculture respectueuse de l'environnement - Trois méthodes passées à la loupe. Solagro Toulouse. 165 pp.
- Jeanneret P., Baumgartner D., Freiermuth R. and Gaillard G. (2006) Méthode d'évaluation de l'impact des activités agricoles sur la biodiversité dans les bilans écologiques – SALCA-BD. Agroscope FAL Reckenholz. 67 pp. (<http://www.reckenholz.ch/doc/fr/forsch/control/bilanz/salca-bd.pdf>).
- Lindeijer E., van Kampen M., Fraanje P., van Dobben H., Nabuurs G. J., Schouwenberg E., Prins D., Dankers N. and Leopold M. (1998) Biodiversity and life support indicators for land use impacts in LCA. IVAM Environmental Research. Publicatiereeks Grondstoffen 1998/07. 60 pp.
- Nemecek T., Huguenin-Elie O., Dubois D. and Gaillard G. (2005) Ökobilanzierung von Anbausystemen im Acker- und Futterbau. *Schriftenreihe der FAL*, 58. 156 pp.

## **Environmental improvement and biodiversity conservation in green areas on an Apennine woodland**

Cervasio F.<sup>1</sup>, Ponzetta M. P.<sup>1</sup>, Argenti G.<sup>1</sup>, Di Prinzio M.<sup>1</sup>, Sacconi F.<sup>1</sup>, Di Leo V.<sup>2</sup>, Genghini M.<sup>2</sup> and Bolognesi L.<sup>3</sup>.

<sup>1</sup>*Departments of Animal Sciences and of Agronomy and Land Management, I-50144 Florence, Italy*

<sup>2</sup>*National Wildlife Institute INFS 40064, Ozzano Emilia (Bo), Italy*

<sup>3</sup>*Regional Park Laghi Suviana e Brasimone, 40032 Camugnano (Bo), Italy*

### **Abstract**

The evolution of hill and mountainous territory in the North Central Apennines, as a result of the abandonment of land for agricultural purposes, has encouraged the progressive plant growth over these green areas, with consequent reduction in biodiversity. In this context we find the infestation of *Pteridium aquilinum* which further narrows down the natural resources of abandoned land which is now of faunal interest. This issue has been examined by the 'Laghi di Suviana e Brasimone' Regional Park (Central Italy) through environmental improvement programmes with faunistic ends, such as clearing and ploughing of pastures and planting of sward-mixtures. The conservation and restoration of the green areas and the up keeping of a well balanced wood to pasture ratio facilitate the management of wild ungulates and hence a reduction in damage to cultivations. Data collection concerns the study of vegetation, botanic composition, floristic richness and biodiversity before and after the intervention efforts. A substantial decrease in fern presence has been observed as well as an increase in biodiversity and a further 300% increase in Pastoral Value. These results confirm the effectiveness of the action taken and the importance of maintaining a continuous programme of pasture management through annual clearing of vegetation.

Keywords: fern, infestation, pastures, ungulates, management

### **Introduction**

Bracken fern (*Pteridium aquilinum*) infestation has been a problem for grasslands in many parts of the world for some time. The spread of bracken fern is dangerous for biodiversity conservation (Ouden, 2000), and it renders the pastures of the infested open areas unavailable for wild fauna. This problem is increasing in Italy too, particularly in abandoned agricultural lands on hill and mountain areas. Eradication is not practicable with current technology, but incisive methods of control are available and have wide applications (Pakeman and Marrs, 1994). However, vegetation under bracken fern is often depauperate and sometimes non-existent (Pakeman and Marrs, 1992) and this is due either to shading by the bracken canopy, physical obstruction, accumulated litter or possible allelopathic effects (Ouden, 2000). This study has examined the effectiveness of several agronomical management systems against intrusive vegetation, in particular relation to the infestation by bracken fern growing over open areas, situated in the "Laghi di Suviana e Brasimone" Regional Park (Central Italy) and once used as pastures by wild ungulates. Preserving a correct ratio pasture area/wood surface is important to permit a better management of wild ungulates and to decrease their damage to the local crops (Danilkin, 1996). It is therefore important to identify sustainable systems of management and conservation of open areas. It is specially important in protected areas

(parks, oasis, etc.), where conserving the biodiversity, emphasizing the ecotonal belt and to improving the wildlife management, represent the primary aims.

## Materials and methods

The trial site called “Monte Calvi” is an open area (6.7 hectares) located inside the studied Regional Park, at about 1200 meters a.s.l., with siliceous sandy soil. The area is considered representative of the environment and vegetation conditions of the other open areas in the Park. Samples of herbaceous vegetation were taken for 4 years, from 2003 to 2006. During this period a useful pasture was established and maintained to reduce the further spread of bracken. The agronomical management system was constituted by the cutting of the fern in the first year, followed by ploughing and sowing of a sward mixture of species (30% *Bromus inermis*, 30% *Dactylis glomerata*, 25% *Festuca ovina*, 10% *Trifolium pratense*, 5% *Lotus corniculatus*). In the following years, the meadow was cut to maintain the introduced vegetation. Ground cover and botanical composition (according to Daget and Poissonet, 1969) were recorded in the summer of every year (2003 to 2006). For each family (G= grasses, L= legumes, O= others) the botanical specific contribution (SC), *i. e.* the percentage of each species in the total of the vegetation, was estimated. Then, the Pastoral Value (PV) of the area was calculated, using the formula:  $PV = \sum (SC_i \times SI_i) / 5$  where  $SI$  is a specific index regarding the forage value of each species in the pasture (Cavallero *et al.*, 2002). Moreover, the floristic richness was evaluated using the Shannon index:  $H' = - \sum p_i \ln p_i$  where  $p_i$  is the percentage of the specific frequency in decimal fraction (Massa and Ingegnoli, 1999). The Shannon index expresses the richness and the evenness of the species in the canopy. Production and quality of the pasture were evaluated through chemical analysis on grass samples, in order to determine: dry matter (DM), crude protein (CP) using the Kjeldhal method (AOAC, 1984), crude fiber (CF) according to Weende (Holst, 1984), NDF and ADF fractions (Van Soest *et al.*, 1991). To evaluate the environmental effects of the management techniques on the botanical composition of the ground cover, the different Pastoral Value and the Shannon index (calculated for each year), were analysed by the following linear model:  $Y_{ij} = \mu + A_i + E_{ij}$ , where  $\mu$ = mean;  $A$ = year ( $i= 1, 2, 3, 4$ );  $E$ = error; data of the chemicals composition of forage (only for the last year) were analysed by the model:  $Y_{ij} = \mu + A_i + E_{ij}$ , where  $\mu$ = mean;  $A$ = month of cut ( $i= 1, 2$ );  $E$ = error (SAS, 2003).

## Results and discussion

The bracken infestation before the agronomical managements was described using vegetation samples taken in July, every year since 2003 until 2006 (Figure 1). The large decrease in the percentage of bracken specific contribution demonstrates that the infestation has actually been reduced as a consequence of the agronomical management.

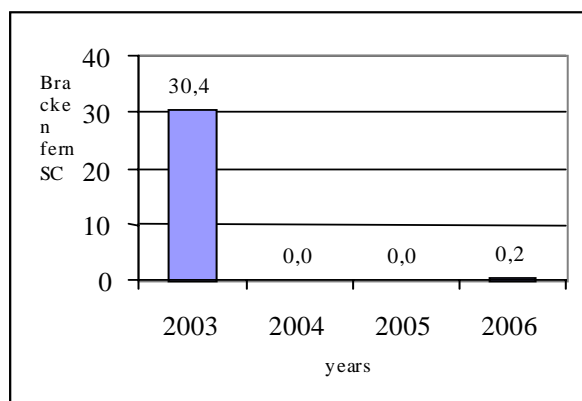

Figure 1. Trend of the bracken fern

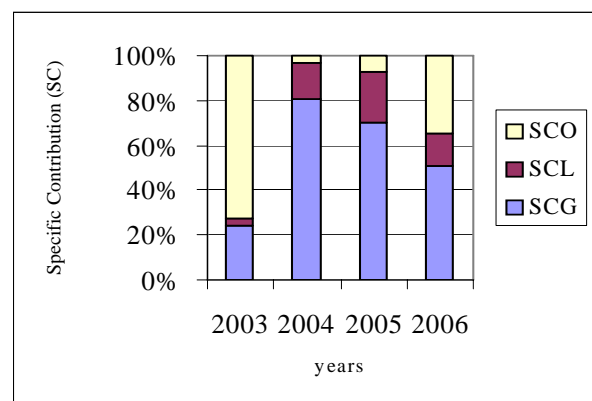

Figure 2. Trend of the Specific Contribution

Specific Contribution (SC)

(SC) of the different botanical families (G, L, O)

The results regarding the vegetation composition of samples taken in the first year showed the presence of species of little interest to herbivores: *Pteridium aquilinum*, *Holcus mollis*, *Anthriscus sylvestris*, *Fragraria vesca*, *Galium mollugo* and *Teucrium scorodonia*.

An improvement on the floristic composition, a decrease in number of species of low quality and an increase in number of botanical families of pastoral interest have been observed after the agronomical treatments. This confirms the positive outcome of the used mixture (Figure 2). During the fourth year *Bromus inermis*, *Dactylis glomerata*, *Festuca ovina* and *Holcus mollis* were the most represented grasses and *Trifolium repens*, *Trifolium pratense* and *Lotus coniculatus* the most present legumes. Species belonging to other families were *Leucanthemum vulgare* and typical species of siliceous soil, such as *Cytisus scoparius* and *Rumex acetosella*.

The analysis of the pasture permitted to highlight (Figure 3) the large increase in the Pastoral Value, negatively affected, before the agronomical works, by the fern cover and by the low presence of legumes. The increased biodiversity shown by the Shannon index (Figure 4) expresses a floristic variety of definite interest for wild fauna.

The presence of wild ungulate can still influence the diversity in canopy species, thanks to the positive effect of grazing (Coughenour, 1991).

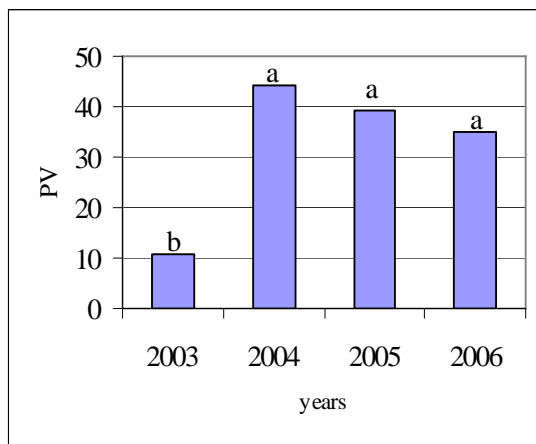

a, b =  $P < 0,05$

Figure 3: Trend of the Pastoral Value PV

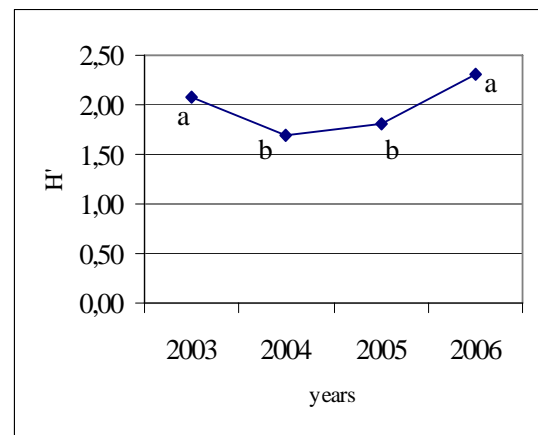

a, b =  $P < 0,05$

Figure 4: Variation of H' Shannon index

Table 1 summarizes some pastoral characteristics found at the end of the study (2006). Pastoral Value (PV) has stabilized on remarkable values, describing a trend in line with the summer climatic characteristics, usually critical in July and August.

Table 1: Seasonal variation of Pastoral Value

Month	PV	SC mix	SC spont	SC G	SC L	SC O	SC B	H'
June	43	48.5	51.5	55.2	14.4	30.4	0.0	2.13
July	35	46.6	53.4	50.5	15.0	34.5	0.2	2.31
August	36	41.9	58.1	46.9	11.5	30.0	0.0	2.00
September	44	49.4	50.6	61.3	13.0	26.2	0.0	2.17

The specific contribute of spontaneous species (SC spont), higher than that of the mixture (SC mix), suggests the positive outcome of the managements and the naturalization of the pastures.

It's also interesting to notice the good distribution in frequency of the botanical species (SCG=Grasses, SCL= Legumes, SCO= other botanical families), and the low presence of bracken expressed by its specific contribution (SCB= Bracken).

In July and September 2006, at each cutting date, the dry matter (DM) production was assessed on about 150 g m<sup>-2</sup>. Samples of the pastures were analysed to examine the

differences in chemical composition (% on DM): crude protein (CP), Ether extract (EE), crude fiber (CF), ash, nitrogen-free extract (NFE), Neutral Detergent Fiber (NDF), Acid Detergent Fiber (ADF) and lignin (Table 2).

Table 2: Chemical analysis on pasture in Monte Calvi open area.

2006	DM (g/m <sup>2</sup> )	H <sub>2</sub> O	CP (%)	EE (%)	CF (%)	Ash (%)	NFE (%)	NDF (%)	ADF (%)	Lignin (%)
July	183.1	6.0	10.2	2.6	24.3	7.2	55.8	50.7	34.6	8.9
September	123.4	4.4	16.2	2.5	23.3	7.4	50.7	56.4	34.4	12.8
Mean	153.3	5.2	13.2	2.5	23.8	7.3	53.3	53.6	34.5	10.8

Even though no statistical difference was found for any of the analysed nutrient (only CP resulted almost significant at 0,0522), the cut in September shows a higher value of CP content and a decrease of CF value, resulting in an increase of the nutritive value in this month. The treatment management seems to have positively affected the quality of the forage, comparable with qualitative characteristics of a good meadow (Piccioni, 1986).

## Conclusions

The “Laghi di Suviana e Brasimone” Park represents a very important reproduction area for the population of red deer (*Cervus elaphus*) on the Tosco-Emiliano Apennines mountains. This land is particularly used by this species in summer and autumn months (September-October), when the food resources are specially important in relation to the higher nutritional requirements connected firstly to the lactation and later to the mating season.

Therefore, a correct conservation of the open areas can represent an important resource for the ecosystem, making the pasture a sTable food resource for wild animals, with positive outcomes on the faunistic management and on the decrease of damages to crops caused by the wild ungulates in the surrounding agricultural areas.

## References

- AOAC (1984) Official Methods of Analysis. Association of Official Analytical Chemists. Arlington, VA.
- Cavallero A., Rivoira G., and Talamucci P. (2002). Pascoli. In “Coltivazioni erbacee. Foraggiere e tappeti erbosi”. Pàtron Editore, Bologna, 239-294.
- Coughenour M.B. (1991) Spatial components of plant-herbivore interaction in pastoral, ranching, and native ungulate ecosystems. *J. of Range Manage.*, 44 (6), 530-542.
- Daget P., and Poissonet Y. (1969) Analyse phytologique des prairies. Applications agronomiques. CNRS-CEPE, Montpellier, doc.48,66 pp
- Danilkin A. (1996) Behavioural ecology of Siberian and European roe deer. -Chapman and Hall, London, 277 pp.
- Holst D. O.,1984. *J.AOAC*, 67 (2), 342.
- Massa R. and Ingegnoli V. (1999) Biodiversità, estinzione e conservazione. Fondamenti di conservazione biologica. UTET.
- Ouden J. den (2000) The role of bracken (*Pteridium aquilinum*) in forest succession. PhD. Thesis, Wageningen University, Wageningen, the Netherlands, 218pp. (Dutch summary).
- Pakeman, R.J. and Marrs R.H. (1992) Vegetation development on moorland after control of *Pteridium aquilinum* (L.) *Khun* with asulam. *Journal of Vegetation Science* 3, 707-710.
- Pakeman R. J. and Marrs R.H. (1994) Bracken Control and Vegetation Restoration: Literature Review. Final Report to the Ministry of Agriculture, Fisheries and Food. Huntingdon: Institute of Terrestrial Ecology.
- Piccioni M. (1986) *Dizionario degli alimenti per il bestiame*. Edizioni Agricole. Bologna, 635 pp.
- SAS/STAT (2003), Edition. Cary, NC:SAS Institute Inc..
- Van Soest P.J., Robertson J.B. and Lewis B.A. (1991). Methods for dietary fiber, neutral detergent fiber, and nonstarch polysaccharides in relation to animal nutrition. *J. Dairy Sci.*, 74, 3583-3598.

# Effect of floristic diversity and habitat conditions on forage value of meadows in the Beskid Sądecki Mountains (Western Carpathians)

Zarzycki J.

*Department of Ecological Bases of Environmental Engineering, Agricultural University, al. Mickiewicza 24/28, 30-059 Kraków, Poland*

## Abstract

Mountain grasslands play an important role in terms of nature, landscape and production. Based on 313 phytosociological relevés done on the mountain grasslands of Beskid Sądecki, relationships were determined between grassland natural value, forage suitability and use history. Three main groups of meadow communities were identified and their biological diversity was evaluated based on the number of species and coefficients of diversity. Forage suitability was calculated based on productive value (LWU). The highest LWU was noted for cultivated meadows found in former arable lands. However, these communities had low diversity indices. The highest biodiversity was a characteristic of bent-grass meadows, which had rather good forage value. The suitability of mat-grass meadows for forage was very low and their floristic diversity was very poor.

Keywords: mountain grasslands, biodiversity, botanical composition, forage value

## Introduction

In addition to being used traditionally in agriculture, grasslands can play many natural and economic functions. They increase biodiversity and recreational and tourist value while contributing to the economic development of regions (Hopkins and Holz, 2005). This is of special importance in mountain areas, where agricultural production faces unfavourable conditions and the locals have no alternative sources of income. Recent socio-economic changes in Poland have led to considerable changes in the methods of land use and in land structure. Complete abandonment of cultivation is particularly unfavourable. These processes are responsible for the disappearance of many extensively used meadow communities and their typical plant species. Another factor is the low productive value of forages originating from these meadows. The aim of the present study was to identify the current state of meadow vegetation in the Beskid Sądecki Mountains and the forage value of meadow communities according to their biodiversity, habitat conditions and utilization history.

## Material and methods

The study was carried out in the Radziejowa mountain range in Beskid Sądecki (Western Carpathians). From 2003 till 2006, a total of 313 phytosociological relevés were made using the Braun-Blanquet method in the meadow communities that differed in terms of flora and habitat. The communities were classified based on numerical analysis performed using MULVA 5 software (Wildi and Orłóci, 1996). The similarity matrix was calculated using van der Maarel's coefficient, and the classification was done using the least variance method. The overall forage value was determined based on the floristic composition, using the indicator method of Filipek (1973), where 0 denotes worthless fodder and 10 the best fodder. Biodiversity was evaluated based on the mean number of species, the Shannon-Wiener diversity index and the Simpson domination coefficient (Magurran, 1988). The method of

past utilization was based on analysis of topographic maps from the late 1970s and early 1980s.

## Results and discussion

The analyzed area is occupied by single farms often situated at high altitudes and difficult to access by vehicles. These farms have preserved the traditionally extensive farming with a variety of meadow communities. Grasslands are located at an altitude of approximately 400 to 1000 m. Most of the studied area is protected (the Poprad Landscape Park). Numerical analysis of the phytosociological relevés has shown three major types of meadow communities: cultivated meadows, bent-grass meadows and mat-grass meadows.

Table 1. Principal characteristics of three grassland groups identified in Beskid Sądecki. F - frequency of occurrence; MC - mean cover.

	Grassland group					
	Mat grass meadows		Bent grass meadows		Cocksfoot meadows	
	F	MC	F	MC	F	MC
Number of relevé	54		110		149	
Average number of species	29.5		39.8		35.9	
Shanon diversity index	2.2		2.7		2.6	
Simpson dominance index	6.7		10.5		9.6	
Average share of grasses	56.5		43.9		47.5	
Average share of legumes	1.4		9.7		13.3	
Average share of herbs	42.1		46.4		39.1	
Average inclination [°]	20.2		20.4		14.4	
Average altitude [m a.s.l.]	763		684		579	
Average forage value	2.9		4.7		6.1	
<i>Vaccinium myrtillus</i>	67	683				
<i>Hieracium lachenali</i>	63	274				
<i>Luzula luzuloides</i>	85	1495	59	721		
<i>Pimpinella saxifraga</i>	63	201	75	286		
<i>Nardus stricta</i>	91	3603	61	489		
<i>Potentilla erecta</i>	94	1577	67	594		
<i>Anthoxanthum odoratum</i>	78	424	80	880	86	1136
<i>Festuca rubra</i>	74	1836	95	2714	87	1213
<i>Agrostis capillaris</i>	87	1269	96	2038	66	763
<i>Festuca pratensis</i>			55	345	74	816
<i>Leontodon hispidus</i>			65	1311	63	731
<i>Plantago lanceolata</i>			92	941	91	729
<i>Briza media</i>			70	830		
<i>Centaurea jacea</i>			64	443		
<i>Trifolium repens</i>			85	1079	90	1644
<i>Dactylis glomerata</i>			58	225	82	1739
<i>Trifolium pratense</i>			69	313	86	1152
<i>Arrhenatherum elatius</i>					52	1449
<i>Taraxacum officinale</i>					80	689
<i>Phleum pratense</i>					65	426
<i>Trisetum flavescens</i>					62	1065
<i>Heracleum sphondylium</i>					68	349

The sward of mat-grass meadows is dominated by grasses (mainly *Nardus stricta*) and poor-habitat species such as *Potentilla erecta* or *Luzula luzuloides* (Tab. 1). These communities are not very luxuriant, have a small number of species and are characterized by low diversity indices (Tab. 1), but they include many protected species. Once widespread in the mountain areas, these communities have disappeared almost completely, mainly because of very low forage value (Tab. 1). They are situated mainly at higher altitudes, often at a considerable inclination. They are sporadically grazed or no longer used. Bent-grass meadows, once dominant in this altitude zone, are increasingly rare. They have rich species composition and are among the most valuable in terms of biological diversity (Tab. 1). They contain many rare and protected species (e.g. orchids). Depending on habitat and utilization conditions, the dominant grasses (such as *Agrostis capillaris* and *Festuca rubra*) grow together with many species of herbs and legumes (Tab. 1), which usually form a large proportion of the sward. These meadows occur at different altitudes and inclinations. They are mowed once a year and fertilized moderately. Their forage value is quite good and depends particularly on the presence of dicotyledonous species, which reduce the fibre content of fodder (Zarzycki *et al.*, 2005). Cultivated meadows are formed at lower altitudes, in locations that are usually flat and have low inclinations. They provide forages of good quality, thanks to the domination of different species of cultivated grasses such as *Dactylis glomerata*, *Arrhenatherum elatius* and *Phleum pratense* (Tab. 1). Cultivated legume species, such as *Trifolium pratense* and *T. repens*, form a considerable part of the sward. Large differences in the species composition of this group result from inappropriate meadow management and particularly improper fertilization, leading to the appearance of many plants characteristic of poor habitats (e.g. *Festuca rubra* and *Anthoxanthum odoratum*). These communities are characterized by low biodiversity (Tab. 1) and occupy the largest part of the analyzed area. Analysis of maps showed that only 5% of the communities classified as mat-grass areas occurred on arable land used some 30 years ago. This proportion was 19% for bent-grass meadows and as much as 60% for cultivated meadows. It resulted from economic changes that took place over the last several dozen years, which caused changes in the structure of land use. Grass and legume mixtures, which produce high yields of good-quality forage, are sown on arable land. However, the species composition of these communities is much poorer with almost no rare plants. This is due to the usually greater fertility of the habitat (Jansens *et al.*, 1998) and the short time over which these communities form (Cousins and Eriksson, 2002). Communities that are the least useful in terms of forage, i.e. mat-grass areas and partly bent-grass areas, are withdrawn from use. The abandonment of use is one of the main threats to the existence of multispecies meadow communities in the mountain areas in many parts of Europe.

## Conclusions

The highest natural value is characteristic of extensively used bent-grass meadows. They also show a relatively high forage value that is sufficient for moderately intensive animal keeping. The best fodder is provided by cultivated meadows established on former arable land. However, the sward is dominated by common species of plants. The lowest nutritive value is characteristic of fodder from mat-grass areas. However, they are worth preserving because they occur rather infrequently and their sward contains some rare species. To maintain the majority of naturally valuable meadow communities, it is necessary to diversify the level of subsidies according to the natural value and fodder suitability of sward from particular meadow types.



## References

- Cousins S.A.O. and Riksson O. (2002) The influence of management history and habitat on plant species richness in a rural hemiboreal landscape, Sweden. *Landscape Ecology*, 17, 517-529.
- Ejrnæs R. and Bruun H.H. (1995) Prediction of Grassland Quality for Environmental Management. *Journal of Environmental Management*, 41, 171-183.
- Filipek J. (1973) Projekt klasyfikacji roślin łąkowych i pastwiskowych na podstawie liczb wartości użytkowej. *Postępy Nauk Rolniczych*, 4, 59-68.
- Hopkins A. and Holz B. (2006) Grassland for agriculture and nature conservation: production, quality and multi-functionality. *Grassland Science in Europe*, 10, 15-35.
- Janssens F., Peeters A., Tallowin J.R.B., Bakker J.P., Bekker R.M., Fillat F. and Oomes M.J.M. (1998) Relationship between soil chemical factors and grassland diversity. *Plant and Soil*, 202, 69-78.
- Magurran A. E. (1988) Ecological diversity and its measurements, Croom Helm Ltd., London, UK, ss. 192.
- Zarzycki J., Gałka A. and Góra-Drożdż E., (2005) Wartość paszowa runi łąk Pienińskiego Parku Narodowego użytkowanych zgodnie z wymogami ochrony przyrody. *Acta Sci. Pol., Agricultura*, 4(2), 119-132.

# Utilisation of wild legumes for increasing species diversity of grassland

Ševčíková M.<sup>1</sup>, Pelikán J.<sup>2</sup>, Gottwaldová P.<sup>2</sup> and Kašparová J.<sup>1</sup>

<sup>1</sup> OSEVA PRO Ltd., Grassland Research Station, 75654 Zubří, Czech Republic

<sup>2</sup> Research Institute for Fodder Plants, Ltd., 66441 Troubsko, Czech Republic

## Abstract

Wild species of the family *Fabaceae* were evaluated as components of a grass seed mixture to increase species diversity in newly established grassland. In 2004, the trials were established in two sites in distinct climatic regions of the Czech Republic, at Troubsko and Zubří. From the germplasm collection 21 species were chosen - *Trifolium alpestre*, *T. rubens*, *T. montanum*, *T. fragiferum*, *T. campestre*, *T. dubium*, *T. medium*, *Lathyrus sylvestris*, *L. tuberosus*, *Galega officinalis*, *Melilotus officinalis*, *Astragalus cicer*, *Astragalus excapus*, *Lotus uliginosus*, *Vicia pisiformis*, *V. villosa*, *V. cracca*, *V. tenuifolia*, *V. angustifolia*, *Lupinus polyphyllus* and *Medicago falcata*. Fifty seeds of a single species were added to the grass seed mixture per experimental plot of 5 m<sup>2</sup>. Their occurrence was monitored over three years. All of the sown species except *Galega officinalis* appeared at Troubsko in the third year, while another three species failed at Zubří. However, the average plant frequency per plot was higher at Zubří, namely 10.4, 14.4 and 14.4% from sown seeds in 2004, 2005 and 2006 respectively (at Troubsko 5.2, 5.4 and 8.1%). The first results showed that in favourable conditions wild legumes appear in the sward even though they comprised a minimal component of the seed mixture.

Keywords: legumes, grassland, species addition, species establishment

## Introduction

Increasing species diversity of grassland communities has been an object of several projects carried out in the Czech Republic. Among different methods the sowing and over-sowing by targeted wild species is a less examined method: Experimental results have been published in the seed multiplication of wild grasses, herbs (Ševčíková and Šrámek, 1998) and legumes (Pelikán *et al.*, 2005), the optimal composition of seed mixtures with respect to proportion of grasses, legumes and herbs (Šrámek and Ševčíková, 2002) and of the methods to establish species-rich grassland (Šrámek and Kašparová, 2004). The aim of the present study was to evaluate the ability of some wild species of the family *Fabaceae* as components of a grass mixture to establish and compete in newly sown grassland swards.

## Materials and methods

The experiment was set up in a split plot design with three replications in two sites in agro-ecologically different areas of the Czech Republic: Troubsko (located 8 km WSW of Brno at an altitude of 280 m a.s.l., annual average temperature 8.5°C, annual rainfall 547 mm, Thermophyticum) and Zubří (located 8.5 km E of Valašské Meziříčí at an altitude of 350 m a.s.l., annual average temperature 7.6°C, annual rainfall 903 mm, Mesophyticum). Species were chosen from the germplasm collection of the Research Institute for Fodder Crops, Ltd. at Troubsko (supported by the National Programme on Conservation and Utilization of Plant Genetic Resources and Agro-biodiversity). Altogether 21 wild legumes were examined for their ability to establish in newly sown grassland when added to a commercial grass seed

mixture. Due to a shortage of seed in the genebank, an identical set of 13 legumes comprising *Astragalus cicer*, *Galega officinalis*, *Lathyrus sylvestris*, *Lotus uliginosus*, *Lupinus polyphyllus*, *Medicago falcata*, *Melilotus officinalis*, *Trifolium alpestre*, *T. medium*, *T. montanum*, *T. rubens*, *Vicia cracca* and *V. villosa* were sown in both locations, while eight other species, namely *Astragalus excapus*, *Lathyrus tuberosus*, *Trifolium campestre*, *T. dubium*, *T. fragiferum*, *Vicia angustifolia*, *V. pisiformis* and *V. tenuifolia* were tested only at Troubsko. Fifty seeds of each species were added to the grass mixture common in the region of cultivation, one species per experimental plot of 5 m<sup>2</sup>, and sown altogether in 2004. The presence and abundance of added legumes were recorded during three vegetation seasons from 2004 (sowing year) to 2006. In addition, the herbage yield was measured in a two-cut regime with a delayed first cut. Data were statistically analysed by using the ANOVA test.

## Results and discussion

Plant establishment varied both with site and species (Table 1) and the variation in the number of plants occurring was statistically significant ( $F=4.59^{**}$  for species and  $11.09^{**}$  for sites).

Table 1. Mean plant occurrence (in % of sown seed) in vegetation period of three years.

Species	Zubří				Troubsko			
	2004	2005	2006	Mean	2004	2005	2006	Mean
<i>Astragalus cicer</i>	0.6	0.6	0.3	0.5	1.3	5.9	8.3	5.2
<i>Astragalus excapus</i> *	-	-	-	-	0.8	0.6	1.3	0.9
<i>Galega officinalis</i>	0.5	0.0	0.0	0.2	0.2	0.0	0.0	0.1
<i>Lathyrus sylvestris</i>	4.0	33.7	38.8	25.5	0.3	5.6	13.2	6.4
<i>Lathyrus tuberosus</i> *	-	-	-	-	2.3	0.7	2.3	1.8
<i>Lotus uliginosus</i>	2.7	6.7	11.3	6.9	1.4	0.1	0.5	0.7
<i>Lupinus polyphyllus</i>	39.8	36.4	27.7	34.6	15.6	9.3	7.5	10.8
<i>Medicago falcata</i>	1.3	0.0	0.0	0.4	1.0	4.6	6.1	3.9
<i>Melilotus officinalis</i>	1.5	0.0	0.0	0.5	6.0	0.8	0.3	2.4
<i>Trifolium alpestre</i>	5.6	19.2	9.2	11.3	2.4	5.0	10.0	5.8
<i>Trifolium campestre</i> *	-	-	-	-	5.7	1.4	1.3	2.8
<i>Trifolium dubium</i> *	-	-	-	-	4.0	0.4	3.5	2.6
<i>Trifolium fragiferum</i> *	-	-	-	-	2.7	3.8	5.4	4.0
<i>Trifolium medium</i>	17.0	34.5	43.8	31.8	1.9	5.6	6.8	4.7
<i>Trifolium montanum</i>	0.3	3.3	6.8	3.4	0.2	0.5	1.9	0.9
<i>Trifolium rubens</i>	7.8	21.9	19.8	16.5	4.2	5.2	5.4	4.9
<i>Vicia angustifolia</i> *	-	-	-	-	15.4	0.6	1.5	5.8
<i>Vicia cracca</i>	1.5	11.4	27.7	13.5	5.7	24.0	40.2	23.3
<i>Vicia pisiformis</i> *	-	-	-	-	0.2	3.4	6.3	3.3
<i>Vicia tenuifolia</i> *	-	-	-	-	11.2	5.2	7.1	7.8
<i>Vicia villosa</i>	52.2	19.2	1.3	24.2	27.8	3.0	0.8	10.5
Site mean (identical set of species)	10.4	14.4	14.4	13.0	5.2	5.4	7.8	6.1
Site mean (all species)					5.2	4.1	6.2	5.2

\* species sown only at Troubsko

Comparing the identical set of thirteen legumes, the site and climatic conditions were generally more suitable for their growth at Zubří (*Mesophyticum carpaticum*), where the mean number of plants present per plot and vegetation period was 10.4%, 14.4% and 14.4% of sown seeds in 2004 (the sowing year), 2005 and 2006, respectively, while the values of 5.2%, 5.4% and 7.8% were found at Troubsko. This can be explained by the relatively higher rainfall and lower water stress at Zubří in extremely dry years compared with Troubsko which

is located in a warm dry region (*Pannonicum*). At Troubsko, among the thirteen species the highest number of plants per plot was recorded with *Astragalus cicer*, *Medicago falcata*, *Melilotus officinalis* and particularly with *Vicia cracca*. However, the initially low number of legumes with tended to increase gradually in swards at Troubsko (Figure 1).

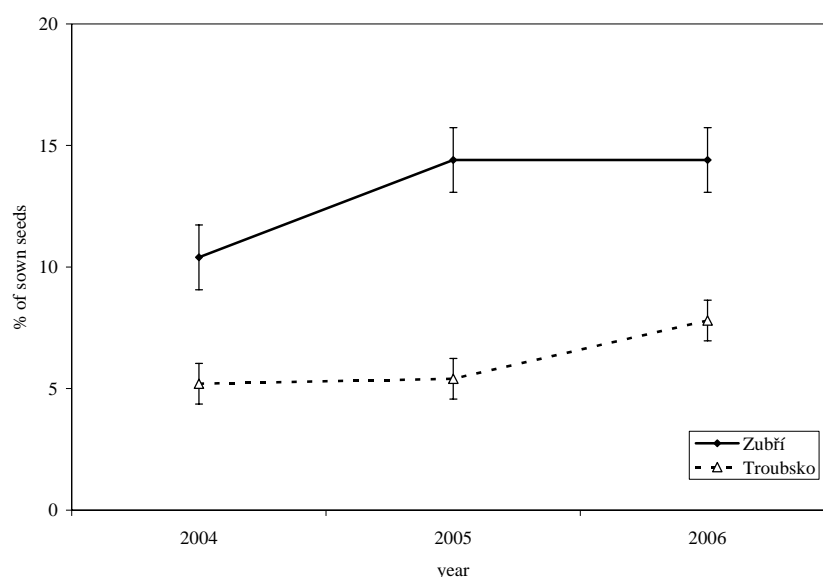

Figure 1. The response of sown set of legumes to climatically different conditions in two locations in the Czech Republic. Vertical bars indicate standard error.

Regarding individual species (Figure 2), *Lupinus polyphyllus*, *Trifolium medium*, *Lathyrus sylvestris*, *Vicia villosa* were the most successful at Zubří and had significantly higher mean numbers of recorded plants during the whole experimental period ( $F=3.79^{**}$  and  $LSD_{0.05(0.01)}=9.4$  (12.7) plants). At Troubsko, the only species which differed significantly from the others was *Vicia cracca* ( $F=2.24^*$  and  $LSD_{0.05(0.01)}=6.0$  (8.1) plants).

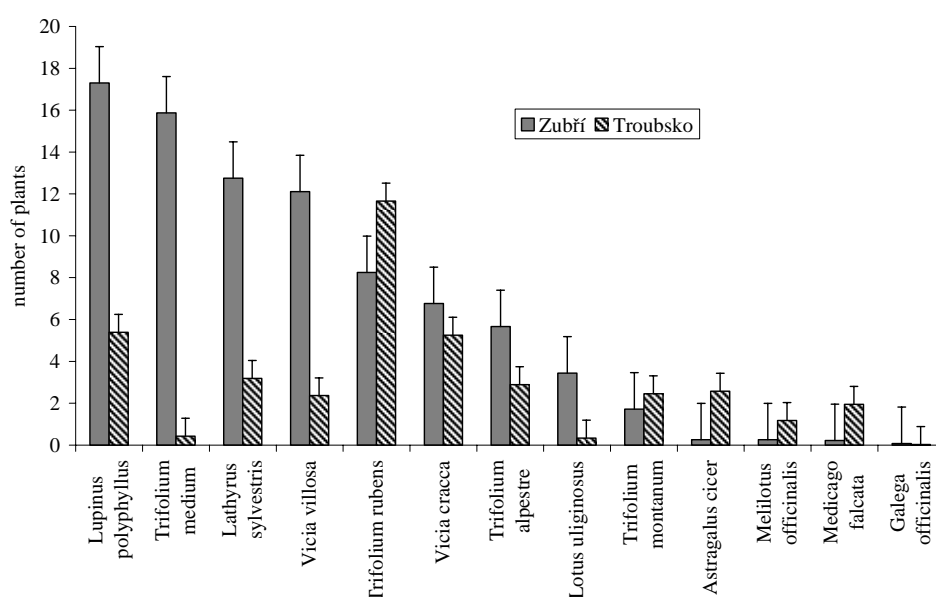

Figure 2. Comparison of establishment of added legumes in two locations in the Czech Republic. Vertical bars indicate standard error.

The herbage yield was influenced significantly by the established legumes in only a few cases (data not shown) and did not always correspond with their frequency. At Zubří, a significantly higher fresh matter yield was observed in plots with the annual to biennial *Vicia villosa* in the year of sowing and in the first cut of the following year and with *Lupinus polyphyllus*, *Lotus uliginosus* and *Lathyrus sylvestris* in the autumn cut of the 2<sup>nd</sup> harvest year. At Troubsko, the only significant higher dry matter yield was found in plots with *Trifolium fragiferum* and *Vicia cracca* in the first cut of the 2<sup>nd</sup> harvest year.

The maintenance of biological diversity has become a special concern of agrarian- and environmental policy. Site specific seeds have been used to introduce well adapted species into cultivated grassland and thereby increase their biodiversity and ecological value (Krautzer and Bohner, 2002). The use of native species is also gaining more and more importance in ecological restoration strategies in the damaged landscape in European countries (Krautzer and Hacker, 2006).

## Conclusions

The botanical succession of newly sown grassland into a species rich meadow is a long-term process. However, after three years of trials it was possible to conclude that most of the wild legumes added to the grass mixtures established successfully in a competitive grassland sward. They occurred in the sward despite their minimal inclusion in the seed mixture and in favourable site conditions they tended to increase their frequency gradually over time.

## Acknowledgements

The study was supported by the Ministry of Agriculture of the Czech Republic (project no. QF3123 and National Programme on Conservation and Utilization of Plant Genetic Resources and Agro-biodiversity).

## References

- Krautzer B. and Bohner A. (2002) Restoration of high altitudes grassland with indigenous seed mixtures. In: Durand J.L., Emile J.C. Huyghe C. and Lemaire G. (eds) Multifunction Grasslands. Quality Forages, Animal Products and Landscapes. Proc. of the 19<sup>th</sup> Gen. Meeting of the EGF, La Rochelle, France. *Grassland Science in Europe* (7) 380-381.
- Krautzer B. and Hacker E. (2006) Soil-Bioengineering: Ecological Restoration with Native Plant and Seed Material. Conference 5 – 9 September 2006, HBLFA Raumberg-Gumpenstein. 291 pp.
- Pelikán J., Vymyslický T., Nedělník J., Gottwaldová P. and Rotrekl J. (2005) Increasing the diversity of forage crop communities. In: Lillak, R., Viiralt, R., Linke, A. and Geherman, V. (eds) Integrating efficient grassland farming and biodiversity. Proc of the 13<sup>th</sup> Int. Occasional Symposium of the EGF, Tartu, Estonia. *Grassland Science in Europe* (10) 569-572.
- Ševčíková M. and Šrámek P. (1998) The seed production of wild grass species for restoring botanical diversity of grassland. In: Nagy, G. and Pető, K. (eds) Ecological Aspects of Grassland management. *Proc. of the 17<sup>th</sup> Gen. Meeting of the EGF*, Debrecen, Hungary. *Grassland Science in Europe* (3) 505-507.
- Šrámek P. and Kašparová J. (2004) Evaluation of different methods for restoration of species-rich grassland. *Biuletyn Ogródów Botanicznych, Muzeów i Zbiorów* (13) 45-48.
- Šrámek P. and Ševčíková M. (2002) The evaluation of botanical composition and productivity of sward sown by species rich mixtures. In: Durand, J.L., Emile, J.C., Huyghe, C. and Lemaire, G. (eds) Multifunction Grasslands. Quality Forages, Animal Products and Landscapes. Proc. of the 19<sup>th</sup> Gen. Meeting of the EGF, La Rochelle, France. *Grassland Science in Europe* (7) 846-847.

# Effects of intensity of fertilisation and cutting frequency on botanical composition of permanent grassland

Odstrčilová V.<sup>1</sup>, Kohoutek A.<sup>1</sup>, Hrabě F.<sup>2</sup>, Rosická, L.<sup>2</sup>, Šrámek P.<sup>3</sup>, Kašparová J.<sup>3</sup>, Komárek P.<sup>1</sup>, Nerušil P.<sup>1</sup>, Gaisler J.<sup>4</sup>, Fiala J.<sup>4</sup>, Pozdíšek, J.<sup>5</sup>, Mičová P.<sup>5</sup>, Svozilová M.<sup>5</sup> and Jakešová H.<sup>6</sup>

<sup>1</sup>*Crop Research Institute Prague 6 - Ruzyně, Research Station Jevíčko, the Czech Republic*

<sup>2</sup>*Mendel University of Agriculture and Forestry in Brno, the Czech Republic*

<sup>3</sup>*Oseva PRO Ltd., Grassland Research Station, Zubří, the Czech Republic*

<sup>4</sup>*Crop Research Institute Prague 6 - Ruzyně, Research Station Liberec, the Czech Republic*

<sup>5</sup>*Research Institute for Cattle Breeding, Ltd., Rapotín, the Czech Republic*

<sup>6</sup>*Hana Jakešová, Hladké Životice, the Czech Republic*

## Abstract

At six sites (Jevíčko, Vatín, Zubří, Liberec, Rapotín and Hladké Životice) in the Czech Republic, the long-term small plot trials with tall oatgrass stand type (*Arrhenatherion*) were established on permanent grasslands in 2003, each consisting of 16 treatments, in 4 replications. The intensity of utilisation: I<sub>1</sub>=(1<sup>st</sup> cut until May 15<sup>th</sup>, 4 cuts per year – cuts at 45-day interval), I<sub>2</sub>=(1<sup>st</sup> cut between 16<sup>th</sup> and 31<sup>st</sup> May, 3 cuts per year at 60-day interval), I<sub>3</sub>=(1<sup>st</sup> cut between 1<sup>st</sup> and 15<sup>th</sup> June, 2 cuts per year at 90-day interval) and I<sub>4</sub>=(1<sup>st</sup> cut between 16<sup>th</sup> and 30<sup>th</sup> June, 1 or 2 cuts per year, second cut after 90 days). Four levels of fertilizer application: F<sub>0</sub>=no fertilisation, F<sub>PK</sub>= P<sub>30</sub>K<sub>60</sub>N<sub>0</sub>; F<sub>PKN90</sub>=P<sub>30</sub>K<sub>60</sub>+N<sub>90</sub>, F<sub>PKN180</sub> =P<sub>30</sub>K<sub>60</sub>+N<sub>180</sub>. This paper is aimed at monitoring of botanical composition which changed under different grassland managements. Species diversity increased territorially, in total 159 plant species were identified. Botanical composition was above all influenced by nitrogen fertilization, which supports grass species and reduces legumes and other forbs. Higher grass proportion was found in two-cut regimes (I<sub>3</sub>, I<sub>4</sub>), too. The diversity of plant species and a more balanced proportion of agrobotanical groups (grasses, legumes, forbs) were found especially in grassland without nitrogen fertilization.

Keywords: permanent grassland, cutting frequency, nitrogen fertilization, biodiversity, botanical composition

## Introduction

In Central and Eastern Europe agriculture has been considerably transformed after the reforms from the early 1990s which has brought livestock decrease by 50 and more %, which deteriorates management and utilisation of permanent grasslands. Agroenvironmental measures in the CR support extensive methods of management which should increase diversity of vegetation, however, it is not sufficiently based on experiments. The proportion of extensively utilised permanent grasslands has recently increased in the CR up to 60 – 80% due to agroenvironmental measures (Czech government enactment no. 242/2004 Sb., on implementation of agroenvironmental measures, in compliance with government enactments no. 542/2004 Sb. and no. 119/2005 Sb.), which leads to a surplus of unfeedable forage (data from Ministry of Agriculture). In Switzerland the law requires a minimum area of 7% of species diverse meadows and pastures (so-called ecological compensation areas) of total area with postponed first cut until June 15 in lowlands and July 15 in mountainous areas (Gujer, 2005), the goal is to reach about 10% of interconnected ecological compensation areas.

Recent research in the CR shows that the optimum extent of extensively managed permanent grassland, cut in mid-June and utilised in cattle feeding ration (dairy and beef cows) during interlactation period, should not exceed 15% of managed area (Kohoutek, Pozdíšek, 2006). For utilising another 1% of so-called "biodiversity" in the CR it would be necessary to increase the cows number by 4 thousand heads which is not real presently and so "a vicious circle" arises. In the CR the livestock numbers decreased (Czech Statistical Office data) from 1256 thousand heads to 570 thousand heads (out of which 140 thousand heads are beef cows) from 1989 to 2004 as a result of declining sales of dairy products and significant increase of milk yield of dairy cows from 3980 to 6000 kg of FCM milk per a cow a year and they are still decreasing. To reach 65% of "biodiversity" it would be necessary to have additional 260 thousand cows, which is not Czech milk and beef market able to absorb.

## Materials and methods

The long-term small plot trials were performed on permanent grasslands at six sites (Jevíčko, Hladké Životice, Vatín, Rapotín, Liberec and Zubří) in years 2003 – 2006. The vegetation of grasslands on the experimental stands was classified as *Arrhenatherion*.

The intensity of utilisation:

I<sub>1</sub> (1<sup>st</sup> cut until May 15<sup>th</sup>, 4 cuts per year – cuts at 45 day interval),

I<sub>2</sub>=(1<sup>st</sup> cut between 16<sup>th</sup> and 31<sup>st</sup> May, 3 cuts per year at 60 day interval),

I<sub>3</sub>= (1<sup>st</sup> cut between 1<sup>st</sup> and 15<sup>th</sup> June, 2 cuts per year at 90 day interval) and

I<sub>4</sub>= (1<sup>st</sup> cut between 16<sup>th</sup> and 30<sup>th</sup> June, 1 or 2 cuts per year, second cut after 90 days).

Four levels of fertilizer application:

F<sub>0</sub>=no fertilisation, F<sub>PK</sub>= P<sub>30</sub>K<sub>60</sub>N<sub>0</sub>; F<sub>PKN90</sub>=P<sub>30</sub>K<sub>60</sub>+N<sub>90</sub>, F<sub>PKN180</sub> =P<sub>30</sub>K<sub>60</sub>+N<sub>180</sub>.

Phosphorus was applied as superphosphate and potassium as potash salt, and nitrogen as calcium ammonium nitrate. Accurate small plot trials are set on a plot area of 10 m<sup>2</sup> in 4 replications. Botanical composition of vegetation is evaluated with a method of projective dominance before each cut in all treatments in 4 replications (Jevíčko, Vatín, Hladké Životice), at sites in Liberec, Rapotín, Zubří only before the first cut from capacity reasons. Over all sites the botanical composition of vegetation was recorded as proportion of agrobotanical groups (grasses, legumes, forbs) and number of vascular plant species. The contribution evaluates the number of detected species per a treatment in all 6 sites over a period of four years, that is from the area of 60 m<sup>2</sup> and the effect of experimental interventions on the representation of botanical groups in the average of sites and evaluated years. The acquired results were statistically evaluated with analysis of variance, the differences between the averages were tested with the Tuckey test on the level of significance of 95% (D<sub>T0,05</sub>), resp. 99% (D<sub>T0,01</sub>).

## Results and discussion

From the attained results in Table 1 is obvious that the intensity of utilisation statistically highly significantly decreases number of species in the vegetation from 82.1 in a four-cut system to 74.0 in an extensive two-cut system. The same tendency is demonstrated at all levels of fertilization (Figure 1). This is related to higher proportion of grasses in the vegetation, which is the lowest in a four-cut system (54.8%) and increases up to 68.1% in a two-cut system and is the same at all levels of fertilization (Figure 2). The increased proportion of grasses reduces proportion of legumes and native species (Figure 3). It is caused by a strong competitive ability of fast growing grasses, because poa family has a double content of chlorophyll compared to other species, which substantially increases their competitiveness and they can even suppress young seedlings of tree species. This finding

breaks the myth that extensive management of grasslands is a way towards higher diversity of grasslands. The level of fertilization towards higher rates of nitrogen statistically significantly decreases the number of species in the vegetation, similarly to extensive management, from 81.6 to 75.1 species. It statistically significantly increases the proportion of grasses in the vegetation 53.8 to 71.2 % and decreases the proportion of forbs (from 36.3 to 26.6%) and legumes (from 9.8 to 2.3 %).

Table 1: The effect of utilisation intensity and fertilization level on the number of species (pcs.60m<sup>2</sup>) in all sites and proportion of grasses, legumes and forbs (%) in the average of 6 sites in 2003 – 2006

Utilisation intensity	Evaluated feature				Fertilization level	Evaluated feature			
	Number of plant species pcs.60m <sup>2</sup>	Grasses	Forbs	Legumes		Number of plant species pcs.60m <sup>2</sup>	Grasses	Forbs	Legumes
		%	%	%			%	%	%
I1	82.1	54.8	36.0	9.2	F <sub>0</sub>	81.6	53.8	36.3	9.8
I2	81.1	59.7	33.6	6.6	F <sub>PK</sub>	80.8	56.4	33.0	10.6
I3	75.8	65.4	28.5	6.1	F <sub>PKN90</sub>	75.6	66.6	28.9	4.5
I4	74.0	68.1	26.7	5.2	F <sub>PKN180</sub>	75.1	71.2	26.6	2.3
D <sub>T0,05</sub>	3.7	1.5	1.6	0.9	D <sub>T0,05</sub>	3.7	1.5	1.6	0.9
D <sub>T0,01</sub>	4.5	1.9	1.9	1.1	D <sub>T0,01</sub>	4.5	1.9	1.9	1.1

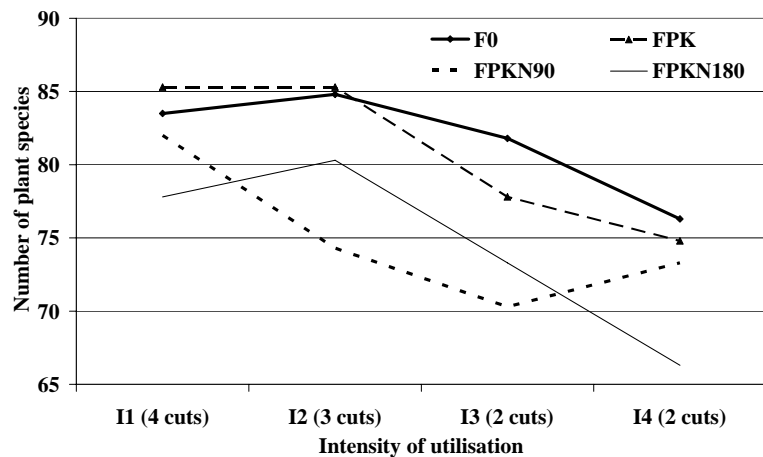

Figure 1: The effect of utilisation intensity and fertilization level on the number of plant species in grassland

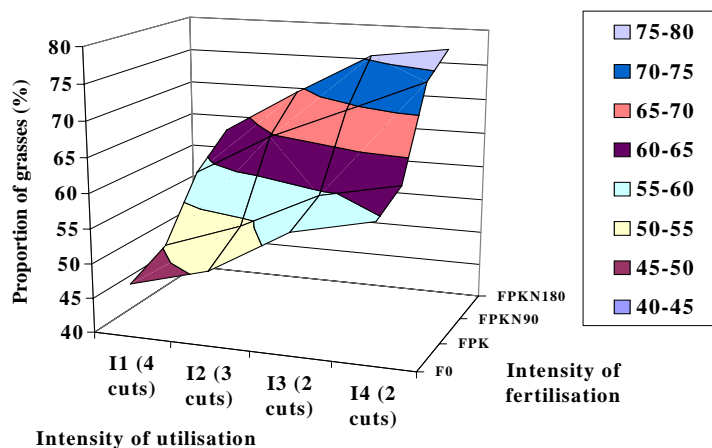

Figure 2: The effect of utilisation intensity and fertilization level on the proportion of grasses in grassland



Nitrogen use cannot be avoided in farming practice because 1 LU of cattle produces annually depending on the composition of feeding ration 60 – 90 kg of nitrogen (urine and liquid faeces) which has to be in the form of farmyard manure (dung-water, slurry, manure) applied to grasslands (Gruber, 2000, Kohoutek, Pozdíšek, 2006). Extensive management of grasslands, that is late cutting, requires higher number of cattle for conversion of low quality forage because voluntary intake of forage decreases. To sustain necessary efficiency higher rates of concentrates have to be used, which also means that the amount of nitrogen excreted by the ruminants increases and so up to 150 kg N ha<sup>-1</sup> has to be applied on the grassland. This increases the amount of produced forage and ecological impact (Gruber, 2000, Kohoutek, Pozdíšek, 2006).

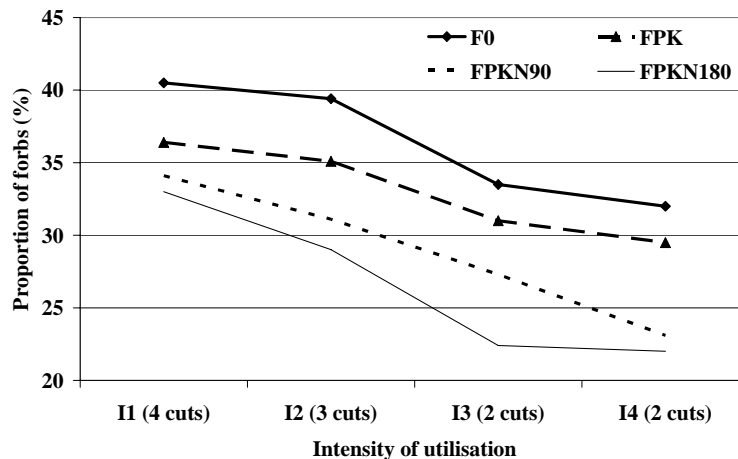

Figure 3: The effect of utilisation intensity and fertilization level on the proportion of forbs in grassland

## Conclusion

The attained results demonstrate that more frequent cutting systems (3 – 4 cuts) and extensive cattle management are optimum from an agricultural and ecological point of view and also from the viewpoint of grassland diversity. A model of sustainable grassland management presents a load by one LU.ha<sup>-1</sup> in the conditions of Central Europe. It is possible to exclude an area of about 1/7 – 1/6 of managed land for extensive grassland management. These results have to be transferred into agroenvironmental programmes in the CR so that these were conceptually and methodologically based on the exact research findings.

## Acknowledgements

The contribution was financially supported by the projects QF3018, VZ0002700601 and MŠMT 2B 06101.

## References

- Gruber L., Steinwider A., Guggenberger T., Schauer A., Häusler J., Steinweder R. and Steiner B. (2000) Einfluss der Grünlandbewirtschaftung auf Ertrag, Futterwert, Milcherzeugung und Nährstoffausscheidung. In: Bericht 27. Viehwirtschaftliche Fachtagung, BAL Gumpenstein 6.-8. 6. 2000, pp. 41-88. ISBN 3-901980-43-1.
- Gujer H. U. (2005) A police to efficiently integrate biodiversity into grassland farming. *Grassland science in Europe*, 10 - Integrating efficient Grassland Farming and Biodiversity, proceedings of the 13th International Occasional Symposium of the EGF (Lillak, R. *et al.* eds). Tartu, Estonia, 29-31 August 2005, pp. 73-79. ISBN 9985-9611-3-7.
- Kohoutek A. and Pozdíšek, J. (2006) Fodder research in the Czech republic focused on permanent grasslands (*in czech*). In: Trávne porasty – súčasť horského poľnohospodárstva a krajiny, mezinárodní vědecká konference u příležitosti 70. výročí pícninářského výzkumu na Slovensku, Banská Bystrica, 27. – 28. 9. 2006, SCPV Nitra, VÚTPHP Banská Bystrica, s. 21 – 27, ISBN 80-88872-56-1.

# Effects of fertilization on the proportion of *Anthoxanthum odoratum*: implications in terms of biodiversity

Susan F. and Ziliotto U.

*Dipartimento di Agronomia ambientale e produzioni vegetali, Università degli Studi di Padova, Campus di Agripolis, viale dell'Università, 16, 35020 Legnaro (Padova), Italy*

## Abstract

*Anthoxanthum odoratum* represents a common species in extensive pastures and permanent meadows. It often plays an important role as a turf grass in mountain areas. The effects of N, P and K fertilization on *Anthoxanthum odoratum* dominance were assessed during year 2004 and 2005. The fertilization trial (that started in 1977) was located on a permanent meadow in the Dolomiti Bellunesi National Park. Nitrogen fertilization highly affected the dominance of *Anthoxanthum odoratum*, significantly increasing the abundance of this species. On the opposite, the significant main effect of K underlined a decrease of this species in the K-treated plots. The highest cover value was observed in the NP-treated plots (27.16%). Shannon Diversity Index (H) and Equitability Index ( $E_H$ ) were negatively correlated with increasing abundance of *Anthoxanthum odoratum* ( $R^2 = 0.81$  and  $R^2 = 0.60$ , respectively). Simpson Dominance Index, on the opposite, highlighted a positive relation with the cover value of this species ( $R^2 = 0.75$ ). In *Anthoxanthum odoratum* dominated plots the dominance-diversity curves pointed out steep, nearly geometric trends. The present work highlighted that the dramatic increase of *Anthoxanthum odoratum* observed as a consequence of fertilization can play an important role in the reducing specific biodiversity of permanent meadows.

Keywords: *Anthoxanthum odoratum*, permanent meadow, fertilization, biodiversity

## Introduction

*Anthoxanthum odoratum* (further referred to as *Anthoxanthum*) represents a common species in extensive pastures and permanent meadows. When grown with other grasses this species, that can reproduce both from seeds and vegetative spreading, can be highly competitive, especially in early spring, due to its rapid growth and early flowering. Later in summer it usually declines in aggressiveness. Previous studies indicated that, compared to other grasses, *Anthoxanthum* can be highly competitive especially for potassium (Remison and Snaydon, 1978; Berendse, 1983). On one hand, this species plays an important role as a turf grass in mountain areas. On the other hand, it can play a major role in reducing specific biodiversity of permanent meadows. The aim of the present research was, firstly, to deepen the knowledge of the effects of inorganic fertilization on the dominance of this grass. Secondly, we tried to better define the relationships between *Anthoxanthum* dominance and specific biodiversity.

## Materials and methods

The present work was realized in a fertilization trial that started in 1977. The experimental area is placed on a mountain permanent meadow (420 m a.s.l.) set in the locality of Candaten (Sedico-Belluno, NE of Italy), within the Dolomiti Bellunesi National Park. An annual average temperature of 10.6 °C and a mean annual rainfall of 1535 mm characterize the climate of the study area. In 1977, the floristic composition of the meadow could be ascribed to the *Arrhenatherum elatioris* association, and to the *salvietosum pratensis* sub-association.

Twenty-seven different treatments, obtained from the factorial combination of 3 levels of nitrogenous (0, 96 and 192 kg of N ha<sup>-1</sup> year<sup>-1</sup>) phosphatic (0, 54 and 108 kg of P<sub>2</sub>O<sub>5</sub> ha<sup>-1</sup> year<sup>-1</sup>) and potassic (0, 108 and 216 kg of K<sub>2</sub>O ha<sup>-1</sup> year<sup>-1</sup>) fertilization have been distributed every year. The experimental design was a randomised complete block with 4 replicates. Plot size was 24.0 m<sup>2</sup> (4.0 x 6.0 m) of which the central 18.0 m<sup>2</sup> (3.0 x 6.0 m) were used as test area. In each plot 3 cuts have been realized yearly; the first cut in the second decade of June, and the others about 50-55 days after the previous one. The effects of mineral fertilization on aboveground productivity of Candaten grassland have been widely analysed in a previous work (Scotton *et al.* 2000). In that study, the application of cluster analysis to annual yield level subdivided all treatments in 6 clusters, characterized by similar productivity (Table 1).

Table 1. Amounts of nutrients (kg ha<sup>-1</sup>) annually supplied to the eight selected treatments since 1977. Cluster analysis results (for the period 1977-1996 and 2004-2005, considering yield level and floristic composition, respectively) and treatments codes used in the text are reported in the first and last column, respectively.

Clusters	N (kg ha <sup>-1</sup> )	P (kg ha <sup>-1</sup> )	K (kg ha <sup>-1</sup> )	Yield <sup>1</sup> (t ha <sup>-1</sup> y <sup>-1</sup> )	Treatment code
N,0	0	0	0	2.47	0 0 0
N,0	96	0	0	3.23	N
P, K	0	108	0	2.68	P
P, K	0	0	216	3.06	K
NP	96	108	0	3.77	NP
NP	192	108	0	3.60	NP
NK	192	0	216	3.13	NK
PK	0	54	216	6.17	PK
NPK	192	54	216	7.97	NPK

<sup>1</sup> Values expressed as the average of period 1977-2000.

During years 2004-2005 a botanical survey (Braun-Blanquet approach) was performed just before each cut. The application of cluster analysis considering floristic composition brought to an identical clustering of treatments. In order to characterize the effects of fertilization on the spread of *Anthoxanthum* 9 treatments (among all 27 treatments) were selected, so that there was at least one treatment representative of each cluster previously individuated (Table 1). ANOVA was performed considering N, P, K, CUT as main factors and cover values of *Anthoxanthum* as dependent variable. Shannon Diversity Index (H), Simpson Dominance Index ( $\lambda$ ) and Equitability Index (E<sub>H</sub>) were also determined to test the effects of fertilization on specific biodiversity. Finally, Whittaker dominance-diversity curves were drawn in order to better define the effects of fertilization on vegetation dynamics.

## Results and discussion

Nitrogen fertilization significantly affected *Anthoxanthum* abundance ( $P < 0.05$ ) (Figure 1). In fact, the per cent cover of this grass was 5.61% higher in the N-treated plots. On the opposite, K fertilization significantly reduced the abundance of this species, highlighting a decrease of 6.17%. Also the single distribution of N and K pointed out, compared to the control, similar trends. Phosphorus addition, instead, did not affect, on the average, the abundance of the grass, and also the presence of only this fertilizer did not bring significant changes in its cover value. *Anthoxanthum* showed the highest cover values in the first part of the season (CUT effect significant at  $P < 0.001$ ) while no differences were detected between second and third cut. The significant N x K and P x K interactions pointed out, in each case, a highest proportion of *Anthoxanthum* when N or P were not associated to K. The highest proportion of

this grass was observed in the NP plots (27.16% in the first cut). Thus, also in the present work *Anthoxanthum* resulted highly competitive especially for potassium. Were K was not associated to N or P, in fact, this species could strongly spread, probably because of a better capacity in K uptake from the soil.

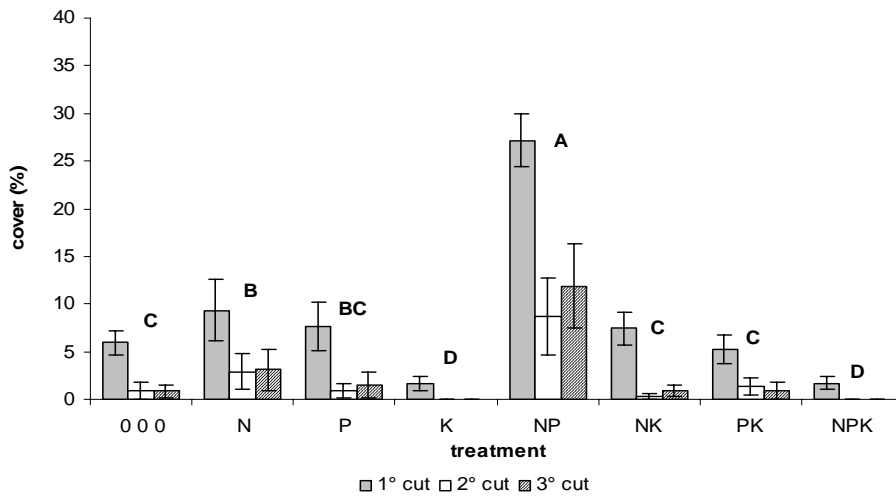

Figure 1. Per cent cover values of *Anthoxanthum odoratum* in the considered treatments. The results are reported for each cut, separately. Treatments with no letters in common are significantly different at  $P = 0.05$  Duncan's test. Duncan's test was performed considering the mean value of all three cuts, and measuring the TREATMENT effect.

In each plot, the total number of species were not correlated with *Anthoxanthum* cover value (results not shown); nevertheless, when the analysis was limited to *Anthoxanthum* cover values higher than 10%, a significant correlation was found between *Anthoxanthum* abundance and Shannon Diversity Index (H), Simpson Dominance Index ( $\lambda$ ) and Equitability Index ( $E_H$ ) (Figure 2).

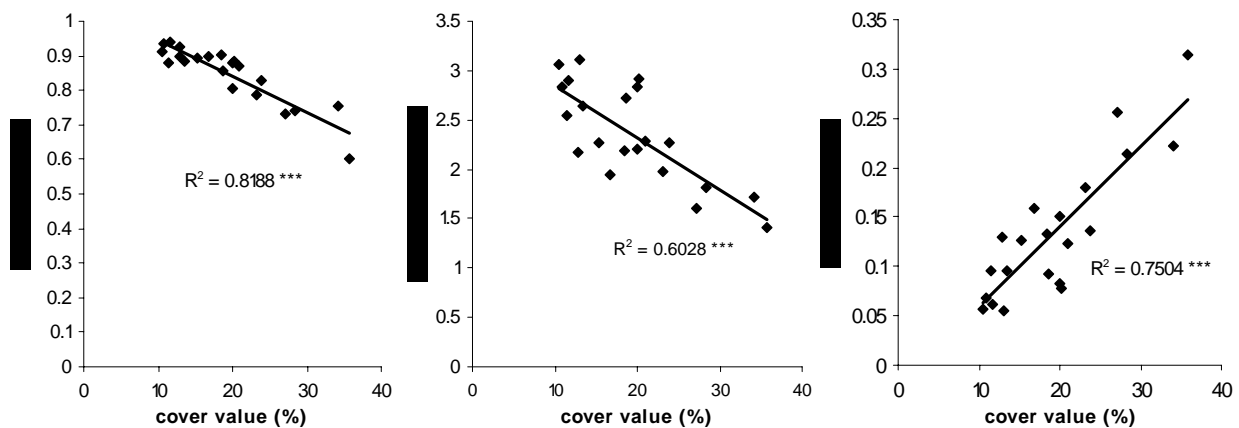

Figure 2. Linear regression analysis, indicating the relationship between different indices and the cover of *Anthoxanthum odoratum*. a) Shannon Diversity Index b) Equitability Index c) Simpson Dominance Index. The regression was performed considering only the cases in which *Anthoxanthum odoratum* cover values exceeded 10%.

In particular, H pointed out a strong negative correlation with the proportion of this grass, underlining the main role of *Anthoxanthum* in limiting the preservation of species-rich communities. The dramatic reduction of species richness was associated to a significant decrease of species evenness and, at the same time, to the higher dominance of a limited number of species. Whittaker dominance-diversity curves highlighted dramatic variations in

function of *Anthoxanthum* abundance in the plot. When *Anthoxanthum* cover values were lower than 10%, in fact, a log-normal trend was observed.

This kind of pattern is representative of situations in which many different species can coexist, in ecosystems that are typically under the control of many independent environmental factors. On the opposite, the *Anthoxanthum* dominated plots resulted in steep, nearly geometric dominance-diversity curves.

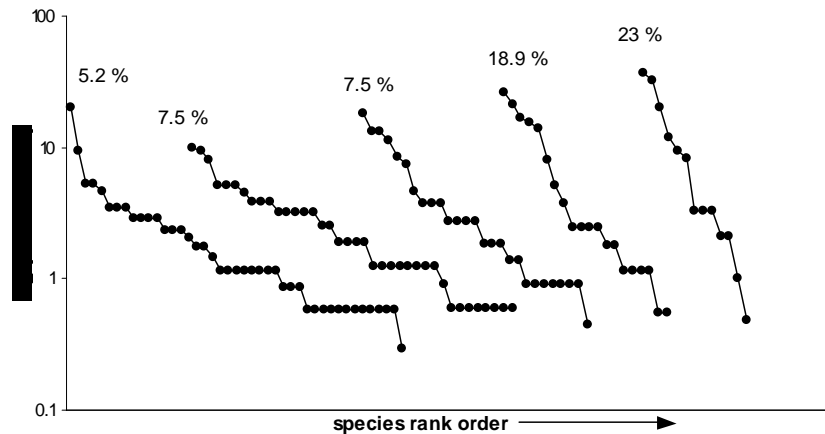

Figure 3. Dominance-diversity curves for increasing levels of *Anthoxanthum* abundance. In each curve, per cent cover values of *Anthoxanthum* are reported on the top.

This trend can be associated to oligotrophic and extreme ecosystems with very low values of specific biodiversity. Thus, the high presence of *Anthoxanthum* results in a hierarchic plant community, where, compared to the control, only few species can survive.

## Conclusions

Nitrogen fertilization significantly affected *Anthoxanthum* abundance, while K addition brought to a decrease on the proportion of this grass. *Anthoxanthum*, on the average, was not influenced by phosphorus addition, even if the highest proportion of this grass was observed in the NP plots. The presence of *Anthoxanthum* in the floristic composition of the grassland was not a good indicator of specific biodiversity; nevertheless, in *Anthoxanthum* dominated plots (> 10%) a clear reduction of Shannon Diversity Index and evenness values was measured for increasing cover values of this species. Fertilization clearly influenced also vegetation dynamics. *Anthoxanthum* dominated plots, in fact, resulted in an extreme ecosystem characterized by a hierarchic plant community, constituted by a limited number of competitive species.

## References

- Berendse F. (1983) Interspecific competition and niche differentiation between *Plantago lanceolata* and *Anthoxanthum odoratum* in a natural hay field. *J. Ecology* 71, 379-390.
- Remison S. U. and Snaydon R. W. (1978) Yield, seasonal change in root competitive ability and competition for nutrients among grass species. *J. Agricultural Science, Cambridge* 90, 115-124.
- Scotton M., Ziliotto U. and Gianelle D. (2000) Influenza della concimazione sugli aspetti quantitativi della produzione di un prato permanente della montagna veneta: risultati di una sperimentazione ventennale. *Riv. Agron.* 34, 132-143.

# The effects of agricultural abandonment on botanical diversity in mountain hay meadows

López-i-Gelats F. and Bartolomé J.

*Department of Food and Animal Science, Veterinary Faculty, VO-306, Autonomous University of Barcelona, 08193 Bellaterra (Cerdanyola del Vallès), Catalonia (Spain)*

## Abstract

Agriculture has been on the decline during the last decades in the Catalan Pyrenees. A research is conducted here on the importance of the traditional livestock farming for botanical diversity conservation in mountain hay meadows all around the Alt Pirineu Natural Park. The process of agricultural abandonment has been alarmingly going forward lately, and two major trends are observed: (a) while sheep farming is in heavy decline and cattle farming keeps relatively stable, horse farming is growing; (b) the increasing transition from cut meadows to partially abandoned meadows. A comparison is conducted among hay meadows grazed by sheep, horses and cattle, and also between cut meadows and the partially abandoned ones. Using the point intercept method botanical transects have been carried out, and analysed by means of DECORANA, TWINSpan and the calculation of the Shannon biodiversity index. After all, one thing can be stated: the process of agricultural abandonment does have an effect on botanical diversity in mountain hay meadows.

Keywords: mountain hay meadow, agricultural abandonment, biodiversity, extensive livestock farming

## Introduction

The Alt Pirineu Natural Park is a recently established natural park in the Catalan Pyrenees. As in many other mountain areas in Europe (MacDonald *et al.*, 2000), the agriculture is on the decline. Here it is characterised by an extensive management of the herd between the alpine grasslands in summer and the hay meadows of the middle-altitude lands in winter. It implies a management of hay meadows based on cutting in summer for hay forage production and grazing in autumn. But lately many hay meadows are being partially abandoned. The mowing is substituted by an additional grazing. This transition from cut meadows to partially abandoned meadows is one sign of the process of agricultural abandonment taking place. Also, this process of agricultural abandonment seems to not to produce the same effects on the three main kinds of livestock farming that we find in the region. While sheep farming is in heavy decline and cattle farming keeps relatively stable, the horse farming shows slight growth (Idescat, 1999). Horse farming is increasing because it is less time-consuming and requires less expertise to be implemented. Our purpose is to assess the influence on botanical diversity in mountain hay meadows of these two particular effects of agricultural abandonment, namely: (a) the substitution of the mowing by an additional grazing; and (b) the response to cattle, horse and sheep farming management.

## Material and methods

A total of 136 botanical transects have been measured in 18 mountain hay meadows during 2005 and 2006. Each hay meadow has been sampled twice, once in summer before the mowing or the grazing and again in autumn before the grazing. Given the objective of our analysis the following were the typologies of hay meadows considered: 4 partially abandoned meadows grazed by sheep and horses; 5 cut meadows grazed by cattle; 4 cut meadows grazed by sheep; and finally 5 cut meadows grazed by horses. All the hay meadows considered shared similar properties, namely: unirrigated land; at least more than 20 years of fidelity to the same farm management; elevation between 1,100 and 1,400 metres; west aspect; and all of them had been cornfields in the past. Plant cover was estimated using the point intercept method as described by Sebastià (1991) for hay meadows in the Catalan Pyrenees. Each sampling consisted of four 5-metre lineal transects laid out in a randomized block design. All the species intercepted by a vertical pointer at 10 cm intervals were recorded along these lines. A value of botanical diversity for each transect has been calculated using the Shannon-Wiener index ( $H'$ ). This index combines the number of species present with the frequency of individuals belonging to each species. Below the formula to calculate the index values is given.

$$H' = -\sum_{i=1}^S p_i \ln p_i$$

Where  $p_i$  is the proportion of species  $i$  in the track,  $\ln$  is the natural logarithm of  $p_i$ , and  $S$  is the number of species. Before analysis, all data were examined for conformation to the assumptions of normality. Four factors that could influence the botanical diversity were tested throughout a one way ANOVA (GLM procedure, SAS Institute inc.): kind of livestock grazing, partially abandoned meadows vs. cut meadows, summer samples vs. autumnal samples, and before grazing vs. before mowing. Significant differences were determined by the Tukey multiple comparison test. Furthermore, in order to determine the affinities among transects the species frequency data have been analysed using a couple of multivariate techniques: Detrended Correspondence Analysis (DECORANA) (Hill, 1979a) and Two Way Indicator Species Analysis (TWINSPAN) (Hill, 1979b). DECORANA ordines and distributes transects in a graph in a way that transects with similar species composition are located close to each other. TWINSPAN divides the entire amount of transects into smaller and more homogeneous groups by producing a dendrogram.

## Results and discussion

The Shannon index values observed - ranging from 1.71 to 3.02, and with a total mean of 2.37 - were concordant with other studies on mountain hay meadows in the Pyrenees (Ferrer *et al.*, 2001). The first outcome that came up from the analysis of the data was found in autumnal transects on cut meadows considering the distinct kinds of livestock farming (horse  $2.13 \pm 0.317$ ; cattle  $2.31 \pm 0.317$ ; and sheep  $2.36 \pm 0.284$ ). The diversity of horse farming meadows were lower than the rest ( $p = 0.0052$ ). This difference is particularly interesting given that autumnal transects were conducted a couple of months after the mowing and some day before the grazing. Considering as well that no significant differences were detected in the very group of transects in summer - before the mowing - this fact seems to point out: either horse farmers manage hay meadow in a different way that influences botanical diversity harmfully and differently from the sheep and cattle farmers' management; or horse grazing has a damaging effect on the structure and composition of hay meadows that only are apparent, as a botanical diversity change, when conditions for the hay meadows community

are not so favourable as it is the case in autumn and not in summer. Both explanations make sense. It should be borne in mind that out of the more than 70 horse farmers working in the region, only one undertakes this activity full time. The overwhelming majority of horse farmers are retired people or part-time farmers. Obviously this fact has an influence on the way hay meadows are managed. We should also keep in mind that, differently from sheep and cattle farming, horse farming never uses sTable. This fact induces farmers to try to keep horses in the given meadow as long as possible and thus presenting a certain tendency towards overgrazing. This difference is best appreciated in the DECORANA ordination of plots (Figure 1). Also, taking into account both cut meadows and partially abandoned meadows in the autumnal sampling, a strong tendency to differentiate between Shannon index means among the hay meadows of the different kind of livestock farming seems to occur; as well as between cut and partially abandoned meadows. In both cases despite the differences found were not significant ( $p = 0.1518$  in cut vs. partially abandoned meadows; and  $p = 0.0559$  in the kind of livestock farming), the Tukey multiple comparison test indicates the existence of separate groups. It asserts that the Shannon index means of cut and partially abandoned meadows are different ( $2.26 \pm 0.440$ , and  $2.38 \pm 0.263$ , respectively). This difference also seems to be corroborated by the DECORANA ordination of transects (Figure 1). Considering the kinds of livestock farming the Tukey test also finds again significant difference between the Shannon index means of two groups: sheep and cattle farming on one side and cattle and horse farming on the other ( $2.36 \pm 0.384$ ,  $2.31 \pm 0.304$ , and  $2.19 \pm 0.333$ , respectively).

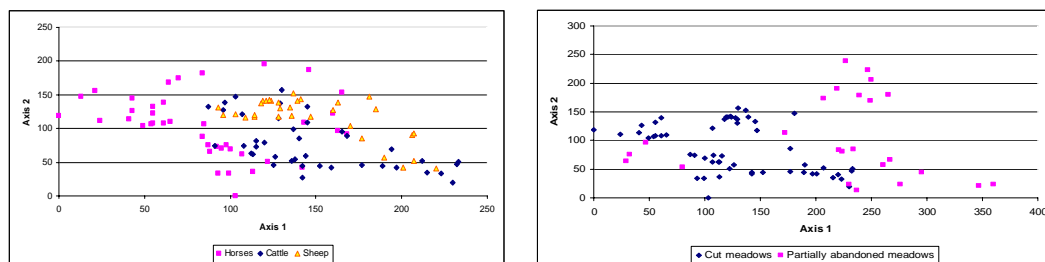

Figure 1. DECORANA ordination of the botanical transects sampled in autumn (cut meadows grazed by horses, cattle and sheep); and DECORANA ordination of the botanical transects sampled in autumn (cut vs. partially abandoned meadows) respectively.

Differences have thus been found in botanical diversity between cut and partially abandoned meadows in the autumnal sampling. This seems to point to a differential effect of mowing and grazing on botanical diversity, apparently in favour of grazing. In this line some scholars insist that the intermediate level of perturbation to which the partially abandoned meadows are subjected - a couple of grazings per year - seems to be an optimal situation to develop mature pastures with high botanical diversity as a consequence of consecutive cycles of perturbation and colonization that allow the cohabitation of opportunistic and dominant species (Díaz *et al.*, 1999). However, it could be the case that partially abandoned meadows favour generalist species, while cut meadows favour specialist species adapted to this particular conditions. In this case the substitution of the cutting by an additional grazing would not be so favourable to biodiversity. This can be observed in the TWINSpan dendrogram (Figure 2). The indicator species for the groups of cut meadows tend to be species more typical of the botanical community of the mountain hay meadows at stake (*Arrhenatherium elatioris*), as it is the case of *Trisetum flavescens*, *Taraxacum officinale* and *Ranunculus sp.*. Whereas in transects done in partially abandoned meadows more generalist species appear, like *Verbascum lychnitis*.



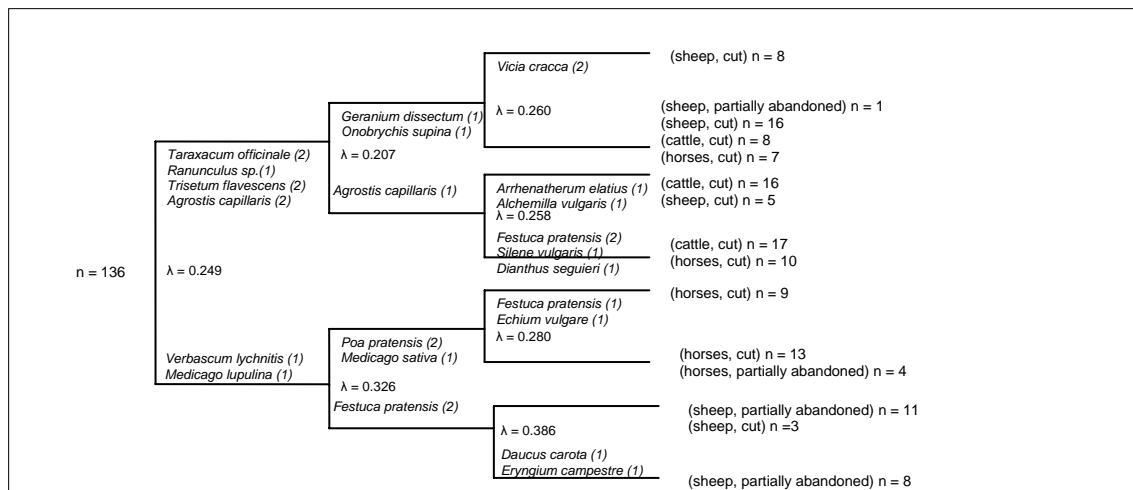

Figure 2. Dendrogram generated by TWINSPLAN with the different groups of botanical transects established by the analysis of indicator species.

## Conclusions

It is observed that the different kinds of livestock farming affect the botanical diversity of mountain hay meadows differently: namely, horse farming impoverishes the botanical diversity. It is also detected that partially abandoned meadows are more botanically diverse than cut meadows. However, this increase seems to be due to a growth in generalist species and at the expense of specialist species. Thus, the substitution of the cutting by an additional grazing does not favour botanical diversity. In conclusion, the two major trends within the process of agricultural abandonment analysed here are found to be harming the botanical diversity of mountain hay meadows.

## Acknowledgements

Acknowledgements are due to Abertis Foundation for its financial support, as well as to Dr. Martí Boada.

## References

- Díaz M.D., Hidalgo, R., Garrido, B., Arroyo, J. and Marañón, T. (1999). Componentes de biodiversidad en bosques y pastos del Parque Natural "Los Alcornocales" (Cádiz-Málaga). Actas de la XXXIX Reunión Científica de la SEEP, Almería, 69-74.
- Ferrer C., Barrantes, O. and Broca, A. (2001) La noción de biodiversidad en los ecosistemas pascícolas españoles. *Pastos*, 31, 129-184.
- Hill M.O. (1979a) DECORANA-A FORTRAN program for detrended correspondence analysis and reciprocal averaging. Ecology and Systematics, Cornell University, Ithaca, NY.
- Hill M.O. (1979b) TWINSPLAN-A FORTRAN program for arranging multivariate data in an ordered two-way Table by classification of the individuals and attributes. Ecology and Systematics, Cornell University, Ithaca, NY.
- Idescat (1999) Cens agrari 1999. Monografies comarcals. Àmbit de l'Alt Pirineu i Aran. Generalitat de Catalunya, Barcelona.
- MacDonald D., Grabtree, J.R., Wiesinger, G., Dax, T., Stamou, N., Fleury, P., Gutierrez Lazpita, J. and Gibon, A. (2000) Agricultural abandonment in mountain areas of Europe: Environmental consequences and policy response. *Journal of Environmental Management*, 59, 47-69.
- Sebastià M.T. (1991) Els prats alpins prepirinencs i els factors ambientals. Doctoral thesis. University of Barcelona. Faculty of Biology. 351 pp.

# Effect of site conditions and utilisation on floristic diversification of *Arrhenatheretum elatioris* meadows

Kryszak A. and Kryszak J.

*The August Cieszkowski Agricultural University, Department of Grassland Science, Wojska Polskiego 28, 60-637 Poznań, Poland*

## Abstract

The objective of the performed investigations was to assess the effect of site conditions and utilisation and fertilisation intensity on the floristic diversification of meadows (*Arrhenatheretum elatioris*). Six floristic types at the rank of sub-associations or variants were identified. The evaluation of site conditions included: content of P, K Mg and N in the soil, soil reaction and moisture content using Ellenberg's phyto-indication method (1992). Floristic diversity was determined with the number of plant species and using Shannon-Wiener indicator.

Rye-grass meadows cut three times and fertilising meadows with high NPK doses resulted in the development of patches with *Arrhenatheretum elatioris dactylidosum glomeratae* were poor in the number of species from which 7.5-9.0 t hay ha<sup>-1</sup> were harvested. Meadows which were not utilised and where no fertilisers were applied *Arrhenatheretum elatioris brizosum mediae* sub-association of low productivity (1.5-2.5 t DM ha<sup>-1</sup>) was found to develop. The highest floristic diversity ( $H' = 3.33$ ) and number of species in a phytosociological survey was determined in the patches of *Arrhenatheretum elatioris typicum* cut two times and fertilised with moderate doses of NPK.

Keywords: *Arrhenatherum elatius*, permanent grassland, habitat, utilisation, diversity

## Introduction

Rye-grass meadows characteristic for the majority of European countries are treated as a combined association of *Arrhenatheretum medioeuropaeum* (Španikova 1984, Ilijanič, Vučković 1982, Ilijanič, Šegulja 1983; Ullmann *et al.*, 1990). Their occurrence and floristic diversity depends, primarily, on the intensity of utilization and, to a lesser degree, on site conditions. Intensive management applied on meadows in the past, i.e. until 1990, caused that, at present, rye-grass meadows developed in their typical form are increasingly rare. On the other hand, the occurrence of numerous variants within the *Arrhenatheretum medioeuropaeum* association is found (Grynja, 1987; Kucharski, Michalska-Hejduk, 1994; Trąba *et al.*, 2003). The objective of the performed investigations was to assess the effect of site conditions and utilisation and fertilisation intensity on the floristic diversification of meadows (*Arrhenatheretum elatioris*).

## Materials and methods

Six of floristic types at the rank of sub-associations or variants were identified from among 1700 surveys taken with the assistance of the Braun-Blanquet method. The performed site investigations comprised the determination of: the soil type, ground water level, soil nutrient resources regarding P (colorimetrically), K and Mg (using the atomic spectrophotometry method). In addition, the authors assessed site conditions, among others: moisture content (F), soil reaction (R) and soil nitrogen content (N) using Ellenberg's indices (1992). Floristic

diversity was determined by means of the estimation in the number of plant species and using the Shannon-Wiener indicator. When assessing the impact of utilisation on the occurrence of species, the following parameters were taken into consideration: type of utilisation, number of cuts and the level of the applied mineral fertilisation.

## Results and discussion

Ryegrass meadows (*Arrhenatheretum elatioris* – A.e.) occur on arid sites which are not flooded. They develop most frequently on peat earths of different levels of mineralisation and less on mineral soils. Their floristic diversity is also influenced by the site moisture content, in particular, by differences in ground water levels during the vegetation season. In the case of wetter sites exhibiting only slight changes in the moisture content between spring and summer, they develop *Arrhenatheretum elatioris alopecuretosum pratensis*, A.e. *sanguisorbetosum officinalis*, var. with *Deschampsia caespitosa* variants resembling communities of the *Molinietalia* order. On the other hand, in the case of sites undergoing drying, especially during late spring and summer on soils with acid reaction, *Arrhenatheretum elatioris dactylidosum glomeratae*, A.e. var. with *Festuca pratensis* variants develop resembling communities from the *Cynosurion* order and in the case of *Arrhenatheretum elatioris brizosum mediae* even up to *Nardo-Callunetea* (Table 1).

Table 1. Effect of site conditions (soil type, moisture content and reaction) on the development of *Arrhenatheretum elatioris* syntaxons.

Syntaxon of <i>Arrhenatheretum elatioris</i>	Soil type	Moisture		F*	R**
		Ground waters level (cm)			
		Spring	Summer		
<i>Typicum</i>	peat earths or shallow peats	40-80	100	5.5	4.5
<i>dactylidosum glomeratae</i>	sandy clay	100	120	4.6	3.7
<i>alopecuretosum pratensis</i>	alluvial soils	30-60	55-90	6.3	5.2
<i>sanguisorbetosum officinalis</i>	mucks	30-50	45-75	5.8	4.1
<i>brizosum mediae</i>	muck-peats	70-100	90-120	4.1	3.0
Var. with <i>Festuca pratensis</i>	mucks	50-75	80-100	5.2	4.4
Var. with <i>Deschampsia caespitosa</i>	muck-clay.	50-85	75-115	6.4	3.8

\* F - moisture indicator values according Ellenberg

\*\* R- soil reaction indicator values according Ellenberg

The content of certain macro elements in the soil is an important factor influencing the floristic diversity of meadows. A higher nitrogen content and lower concentrations of potassium and phosphorus in the soil favour the development of *Arrhenatheretum elatioris dactylidosum glomeratae* and A.e. *alopecuretosum pratensis* variants – poorer in the number of species and characterized by lower floristic diversity (Tables 2 and 3).

Table 2. Impact of N, P, K and Mg concentrations on the development of *Arrhenatheretum elatioris* syntaxons.

Syntaxon of <i>Arrhenatheretum elatioris</i>	*N	P	K (mg kg <sup>-1</sup> DM of soil)	Mg
<i>Typicum</i>	4.8	323.1	326.5	452.0
<i>dactylidosum glomeratae</i>	5.7	185.9	254.1	263.5
<i>alopecuretosum pratensis</i>	5.2	213.0	205.3	391.0
<i>sanguisorbetosum officinalis</i>	3.2	201.5	398.7	198.7
<i>brizosum mediae</i>	3.5	330.2	311.8	384.2
Var. with <i>Festuca pratensis</i>	5.0	381.7	315.9	403.1
Var. with <i>Deschampsia caespitosa</i>	3.8	195.7	295.4	257.2

\*N – soil N content, indicator according to Ellenberg

Apart from site conditions, the development of *Arrhenatheretum elatioris* syntaxons is strongly influenced by fertilisation and utilisation. Higher fertilisation doses and increased number of cuts leads to the development of *Arrhenatheretum elatioris dactylidosum glomeratae*, *A.e. alopecuretosum pratensis* variants as well as *A.e.* var. with *Festuca pratensis* characterized by lower floristic wealth but higher yields (Table 3).

Table 3. Effect of utilization and N fertilisation on the floristic diversity and yields of ryegrass meadows.

Utilisation + fertilisation NPK	Syntaxon of <i>Arrhenatheretum elatioris</i>	Number of plant in surveys (mean, range)	H'	DM yields (t ha <sup>-1</sup> )
2 cuts + 100 kg ha <sup>-1</sup>	<i>typicum</i>	37.5 (25-49)	3.33	5-7
3- 4 cuts + 150 kg ha <sup>-1</sup>	<i>dactylidosum glomeratae</i>	14.3 (6-20)	1.96	7.5-9.0
2 cuts + 100 kg ha <sup>-1</sup>	<i>alopecuretosum pratensis</i>	23.7 (20-34)	2.95	4.0-6.0
1 cut + 0 kg ha <sup>-1</sup>	<i>sanguisorbetosum officinalis</i>	29.1 (24-36)	3.20	3.0-4.8
Non utilisation and fertilisation	<i>brizosum mediae</i>	19.2 (17-29)	2.72	1.5-2.5
2 cuts + 100 kg ha <sup>-1</sup>	var. with <i>Festuca pratensis</i>	21.5 (22.9-31.0)	2.80	4.5-6.5
1 cut + 0 kg ha <sup>-1</sup>	var. with <i>Deschampsia caespitosa</i>	17.9 (15-22)	2.22	2.5-3.5

The analysis of the obtained research results revealed that site moisture content, soil nitrogen concentration and cutting frequency exerted the strongest influence on the floristic diversity and species wealth of ryegrass meadows. In moderately wet, fertile and intensively utilised (at least two cuts) sites floristically poorer but characterised by higher yields variants of *Arrhenatheretum elatioris dactylidosum glomeratae*, *A. e. alopecuretosum pratensis*, var. with *Festuca pratensis* developed.

For example, cutting the grass three times and fertilising meadows with high NPK doses resulted in the development of patches with *Arrhenatheretum elatioris dactylidosum glomeratae* poor in the number of species from which 7.5-9.0 t hay ha<sup>-1</sup> were harvested.

On the other hand, on ryegrass meadows which occur on relatively dry muck-peat soils which were not utilised and where no fertilisers were applied, *Arrhenatheretum elatioris brizosum mediae* sub-association of low productivity (1.5-2.5 t DM ha<sup>-1</sup>) was found to develop. The highest floristic diversity (H' = 3.33) and number of species in a phytosociological survey was determined in the patches of *Arrhenatheretum elatioris typicum* cut two times and fertilised with moderate doses of NPK.

Recapitulating, ryegrass meadows exhibit significant floristic diversity which depends on site conditions as well as on the intensity of utilisation and mineral fertilisation. This results in considerable floristic variability of *Arrhenatheretum elatioris* as expressed by the occurrence of numerous variants and sub-associations.

## Conclusions

The highest floristic diversity was determined in variants of *Arrhenatheretum elatioris* occurring in moderately wet sites (F = 5.5) and lower nitrogen content (N from 3.0 – 3.5).

In order to maintain higher floristic diversity, the recommended way of utilization of these meadows should not exceed more than two cuts during the vegetation period.

Elevated contents of nitrogen in the soil lead to the development of sub-associations of low floristic diversity.

## References

- Ellenberg H. (1992) Zeigerwerte von Pflanzen in Mitteleuropa. *Scripta Geobotanica*, 18: 1-258.
- Grynia M. (1987) Geobotanical characteristics and the economic value of the *Arrhenatheretum elatioris* association in Great Poland district. *Zeszyty Problemowe Postępow Nauk Rolniczych*, 308, 81-86.
- Ilijanič L. and Šegulja N. (1983) Phytozonologische und Ökologische Untersuchungen der glatthaferwiesen in der Podravina (Nordkroatien). *Acta Bot. Croat.* 42: 63-82.
- Ilijanič L. and Vučković R. (1982) Steppensalbei-Glatthaferwiesen in der Umgebung von Sečanj in der Vojvodina. *Acta Bot. Croat.* 41: 93-102.
- Kucharski L. and Michalska-Hejduk D. (1994) Review of meadow communities from *Molinia-Arrhenatheretea* distinguished in Poland. *Wiadomości Botaniczne*, 38(1/2), 95-104.
- Španikova A. (ed.) (1984) Vegetačné pomery južnej časti vychodoslovenskej nížiny. *Acta Botanica Slovaca*, 9, 1-189.
- Ullmann I., Heindel B. and Schug B. (1990) Naturräumliche Gliederung der Vegetation auf Straßenbegleitflächen im westlichen Unterfranken. *Tuexenia*, 10, 197-222.
- Trąba C., Wolański P. and Woźniak L. (2003) The differentiation of meadows of the *Arrhenatheretum elatioris* association in the river valleys of Zamość Basin. *Grassland Science in Europe*, 8, 610-612.

# Floristic diversity and biomass production in former intensively used grasslands (Flanders)

Demolder H.

Research Institute for Nature and Forest, Kliniekstraat 25, 1070 Brussels, Belgium

## Abstract

In 2003 a grassland monitoring scheme in former intensively used grasslands was launched. In 2005 twenty seven plots were selected for more detailed analysis on biomass production and floristic diversity. Most grasslands are species poor (5-15 species/9m<sup>2</sup>). Meadows on wet light sandloam soils have the highest floristic diversity. The above ground production is for the majority of the grasslands between 4-6 ton/ha. This value indicates that high species density can occur but in this study it is only the case in a few grasslands (n=5).

Keywords: species diversity, management, biomass production, grassland

## Introduction

Semi-natural grasslands have become very rare in Flanders (North Belgium). Due to the intensification of agriculture, many of these vegetation types are replaced by high intensively used grasslands. As a consequence, a lot of meadows and pastures in nature reserves are former intensively used grasslands or even fields. In order to optimize restoration policy and conservation practice, more information about the evolution of these vegetations is necessary. Therefore a grassland monitoring scheme was launched in 2003. In 2005, twenty seven grasslands were selected for more detailed analysis on biomass production.

## Materials and methods

To record vegetation changes 80 permanent quadrates (period 2003-2005) were set up in several grasslands with various soil conditions and with different management practices (mowing, grazing and aftermath grazing). The Londo scale for permanent plots was used for estimating the coverage of the plant species. For each management practice and for three soil types (wet light sandloam to loamy sand = group 1; dry loam and sand loam = group 2 and wet heavy clay = group 3), with tree replica's in each case, grasslands were selected for more detailed analysis on biomass production. Fresh weight yields were determined at the end of June by cutting 4m<sup>2</sup> in each quadrate. Dry matter content was measured by drying subsamples at 65°C for 72 hours. The relation between plant species diversity, biomass production and soil type is examined for the three groups. For indicating floristic diversity we calculated the Shannon-Wiener Index (H') and data on soil conditions were obtained by using the Belgian Soil Map and Geographic Information System.

## Results and discussion

Most grasslands are species poor (5-15 species/9m<sup>2</sup>) with dominant high productive grasses like *Alopecurus pratensis*, *Holcus lanatus* and *Lolium perenne*. A minority of the grasslands is species rich (> 15 species/9 m<sup>2</sup>). In the sward common herbs like *Ranunculus acris*, *Rumex acetosa*, *Cardamine pratensis* and *Lotus corniculatus* are often found. Based on their floristic composition they were assigned to poorly developed *Arrhenaterion elatioris* Koch 1922.

Group 2 on wet light sandloam to loamy sandsoils has the highest mean index for floristic diversity ( $H'$ ). Group 1 and Group 3 exhibit almost the same value (Table 1).

The value of biomass production varies from 4 to 9 ton/ha. The majority of the grasslands have a value between 4-6 ton/ha. Oomes (1992) found that a high species density can occur when a seasonal dry matter production is between (4.6-6.0 ton/ha ). In our study this is only the case for a few grasslands (n=5). Values exceeding 6-7 ton/ha result in a decreasing of species density (Oomes 1992). Grasslands with values bigger than 6.0 ton/ha are relatively more represented in Group 3. This group has the highest mean value of above ground production. Group 1 and Group 2 have nearly the same average herbage yield, but their floristic diversity index ( $H'$ ) is different, with the highest number in Group 2. Further research (e.g. on vegetation structure) is needed to find an explanation for this. Maybe the vegetation of group 1 has taller species that intercept more light. This reduces species density, despite a comparable level of dry matter production (Bobbink and Willems 1987). The low values of biomass in both groups are probably due to the fact that they are situated on loam, (light) sandloam to loamy sand, which are generally more nutrient poor than clay soils. Because of this, lowering the level of biomass by nature management (no fertiliser application, appropriate cutting regime) is easier. The grasslands of group 3 are situated on heavy clay soils which are nutrient rich by nature and as a result give a higher above ground production. Restoration to species rich grassland goes slower here.

The mean values of biomass production were also calculated for the different management practices (Table 2). Grasslands that are grazed only have a higher average above ground production than mown (with or without aftermath grazing) grasslands. Solely cutting gives a lower mean herbage yield than mowing with aftermath grazing. Cutting seems a more efficient measure to reduce the above ground production.

Table 1. Soil types, Shannon-Wiener Index and biomass production of the three different groups.

	Group1	Group 2	Group3
Soil type	wet light sandloam to loamy sand	dry loam and sand loam	wet heavy clay
Shannon- Wiener Index ( $H'$ )	1.56 (SD 0.43)	1.89 (SD 0.45)	1.62 (SD 0.48)
Biomass production (ton/ha)	5.9 (SD 1.3)	5.7 (SD 1.4)	7.06 (SD 2.10)

Table 2. Biomass production (ton/ha) for the three management practices (grazing, cutting, aftermath grazing).

	Grazing	Cutting	Aftermath grazing
Biomass production	7.25 (SD 1.24)	5.75 (SD1.58)	6.16 (SD 1.94)

## Conclusions

Most grasslands are species poor. The highest floristic diversity is found in meadows on wet light sandloam soils. The above ground production is for the majority of the grasslands between 4-6 ton/ha. This value indicates that high species density can occur but in this study it is only the case in a few grasslands. Grasslands that are grazed only have a higher average above ground production than mown (with or without aftermath grazing) grasslands.

## References

- Bobbink R. and Willems J.H. (1987). Increasing dominance of *Brachypodium pinnatum* (L.) Beauv. In chalk grasslands: a threat to a species- rich ecosystem. *Biol. Conserv.* 40:301-314.
- Hennekens S.M. (1995) Turbo(Veg). *Programmatuur voor invoer, verwerking en presentatie van vegetatiekundige gegevens. Gebruikershandleiding.* IBN-DLO Giesen and Geurts, The Netherlands, 64 pp.
- Londo G. (1976) The decimal scale for relevés of permanent quadrats. *Vegetatio*, 33, 61-64.
- Oomes M. J.M. (1992) Yields and species density of grasslands. *Journal of Vegetation Science* 1, 333-338.



# Effect of *Lolium perenne* L. variety on the botanical composition of grass-clover mixtures

Suter D., Briner H.U. and Lüscher A.

*Agroscope Reckenholz-Tänikon Research Station ART, 8046 Zurich, Switzerland*

## Abstract

The primary task of variety testing is to guarantee that the progress made in plant breeding is transferred to the farmer by recommending the varieties most suitable for the respective climatic, edaphic and production-system related conditions. It is therefore important to know how well suited new varieties are for use in grass-clover mixtures.

Two new varieties of *Lolium perenne* L. were compared with two five to fifteen years older varieties in the third year of growth. The *L. perenne* varieties grew in two different grass-clover mixtures under moderate fertilisation (125 kg N ha<sup>-1</sup> yr<sup>-1</sup>): in a simple mixture in competition with two clovers (*Trifolium pratense* L. and *Trifolium repens* L.) and in a more complex mixture with the two clovers and the three grasses *Poa pratensis* L., *Festuca rubra* L. and *Phleum pratense* L. The 'new' varieties of *L. perenne* exhibited much larger proportions of dry-matter yield than the 'old' varieties: 54% in simple and 41% in complex mixtures vs. 34% and 8% respectively, revealing an important increase in competitive ability and persistence. It is concluded that: i) progressively including the best new varieties in the list of recommended varieties improves the potential of grass-clover mixtures and ii) the composition of seed mixtures for leys has to be adapted periodically to the competitive ability of new varieties.

Keywords: varieties, *Lolium perenne*, perennial ryegrass, grass-clover mixtures, leys

## Introduction

In comparison to pure grass stands, grass-clover mixtures under moderate N fertilisation are characterised by higher dry matter yields (Lüscher and Aeschlimann, 2006, Kirwan *et al.*, 2007), higher forage intake (Rochon *et al.*, 2004) and an improved evenness in seasonal growth patterns (Elgersma *et al.*, 1998). Additionally, the legumes supply the plant-soil system with considerable amounts of nitrogen through biological nitrogen fixation (Zanetti *et al.*, 1997) leading to a substantially increased total N yield of the mixture. Due to synergistic effects, N yield of the grass grown in mixture can be even higher than for the grass grown in pure stands (Lüscher and Aeschlimann, 2006). The flexibility of combining different forage plant species permits the design of mixtures adapted to specific environmental conditions and utilisation systems (Suter *et al.*, 2004). The botanical composition of a plant stand from a grass-clover mixture is mainly determined by the interspecific competition. Because competitive ability can vary among varieties of a plant species (Suter *et al.* 2006) the botanical composition may be influenced by the varieties used. To take advantage of the genetic progress brought about by plant breeding, variety testing seeks to find the best varieties for forage production needs, in respect to climatic, edaphic and production-system related conditions. The resulting list of recommended varieties is the basis for grass-clover mixtures. Thus it is of great interest to know:

- i) how high the performance advantage of new varieties is compared to old varieties and

- ii) to what degree the botanical composition of grass-clover mixtures is altered when new varieties are included in the seed mixture.

## Materials and methods

Four varieties of *Lolium perenne* L. were tested at the Agroscope Reckenholz-Tänikon Research Station ART in Zurich, Switzerland. The varieties differed according to the years they were first recommended: the 'old' varieties 'Merlinda' (early heading, recommended in 1991) and 'Condesa' (late heading, recommended in 1986) and the 'new' varieties 'Arvicola' (early heading, recommended in 1996) and 'Alligator' (late heading, recommended in 2001). The varieties were grown in two different types of grass-clover mixtures (Table 1):

- i) in a simple mixture in competition with two clovers (*Trifolium pratense* L. and *Trifolium repens* L.)
- ii) in a more complex mixture with the two clovers and the three grasses *Poa pratensis* L., *Festuca rubra* L. and *Phleum pratense* L.

The experiment was set up as a completely randomised block design with four blocks. The plot size was 6 × 1.5 m. The mixtures were fertilised with 80 kg P<sub>2</sub>O<sub>5</sub> ha<sup>-1</sup> and 240 kg K<sub>2</sub>O ha<sup>-1</sup>, applied at the beginning of the growing season. Each of the five cuts per year was fertilised with 25 kg N ha<sup>-1</sup>, applied as NH<sub>4</sub>NO<sub>3</sub>, resulting in a total of 125 kg N ha<sup>-1</sup> yr<sup>-1</sup>.

The experimental plots were cut with a plot harvester (Hege 212) at a cutting height of 8 cm. In the third growing year, the botanical composition was analysed: in each plot about 1 kg of herbage was randomly sampled above cutting height and separated into *L. perenne*, other grasses, and clover.

Table 1. Composition (kg seed ha<sup>-1</sup>) of mixtures with 'new' and 'old' varieties of *Lolium perenne* L., respectively and clover (*Trifolium pratense* L. and *Trifolium repens* L.): simple mixtures and complex mixtures with three additional grass species.

species	variety	kg seed ha <sup>-1</sup>					
		simple				complex	
		old	new	old	new	old	new
<i>Trifolium pratense</i> L.	<i>Merviot</i>	1.0	1.0	1.0	1.0	1.0	1.0
<i>Trifolium repens</i> L.	<i>Regal</i>	2.5	2.5	2.5	2.5		
	<i>Seminole</i>					2.0	2.0
	<i>Sonja</i>	1.5	1.5	1.5	1.5	1.0	1.0
<i>Lolium perenne</i> L. (early heading)	<i>Merlinda</i>	12.0				5.0	
	<i>Arvicola</i>		12.0				5.0
<i>Lolium perenne</i> L. (late heading)	<i>Condesa</i>			12.0		5.0	
	<i>Alligator</i>				12.0		5.0
<i>Poa pratensis</i> L.	<i>Lato</i>					10.0	10.0
<i>Festuca rubra</i> L.	<i>Echo</i>					5.0	5.0
<i>Phleum pratense</i> L.	<i>Richmond</i>					3.0	3.0
total		17.0	17.0	17.0	17.0	32.0	32.0

## Results and discussion

The proportion of *L. perenne* in the harvested dry matter (DM) in the simple mixture was significantly greater ( $P < 0.001$ ) in the mixtures with 'new' *L. perenne* varieties (54%) than in the mixture with 'old' varieties (34%) (Figure 1). This difference was much more obvious in the early heading varieties than in the late heading varieties. The advantage of the 'new' varieties reflects their improved competitive ability in competition with clovers. The high proportion of *L. perenne* in the third year also reflects a markedly increased persistence. Similar results for 'old' and 'new' varieties could also be found in other experiments for *Dactylis glomerata* L. (Lehmann *et al.*, 1997) and *Festuca pratensis* Hudson (Lehmann *et al.*, 1998) in simple mixtures with *T. repens* and *T. pratense*. One of the factors leading to a better competitive ability of the 'new' *L. perenne* varieties may be their earlier heading dates (Lehmann *et al.*, 2001). Additionally, the improved winter hardiness of the 'new' varieties (Lehmann *et al.*, 2001) could also have played an important role. The fact that the 'new' varieties were present at higher rates than the 'old' varieties guarantees the transfer of the genetic progress of the 'new' varieties to the grass-clover mixtures. In a system, in which the grass-clover mixtures are based on recommended varieties, the composition of the recommendation list is of utmost importance.

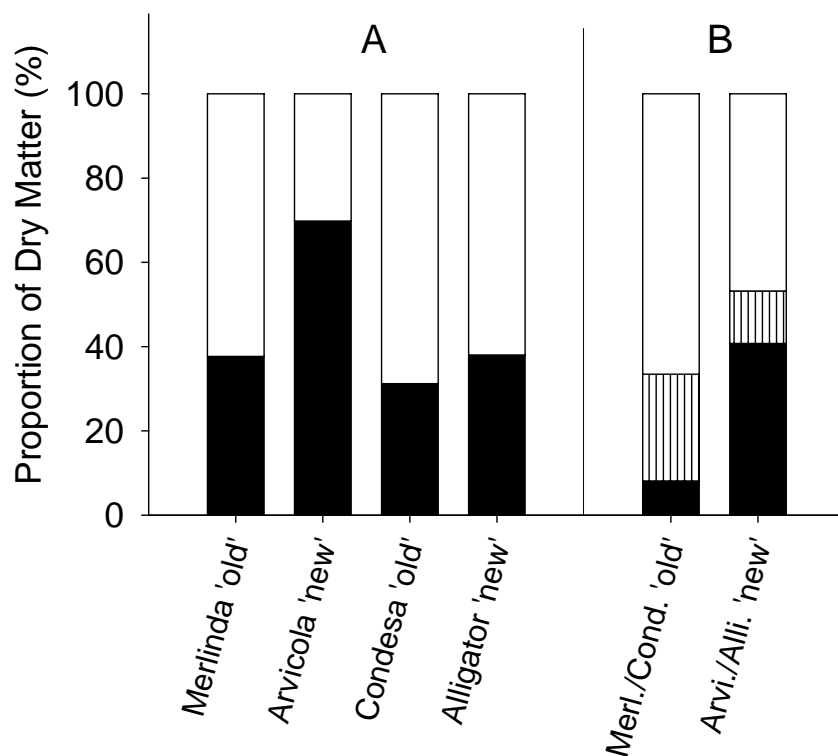

Figure 1. Proportion of dry matter yield of 'new' and 'old' varieties of *Lolium perenne* L. grown with clover (*Trifolium pratense* L. and *Trifolium repens* L.): A) in simple mixtures and B) in complex mixtures with three additional grass species. Data from the third growing year. Solid bars = *L. perenne*, light bars = clover, vertical pattern = other grasses.

The 'new' varieties of *L. perenne* exhibited in the complex mixture a significantly ( $P < 0.001$ ) higher *L. perenne* proportion (41%) than the 'old' varieties of *L. perenne* (8%) (Figure 1). This suggests that a marked performance in a variety's competitive ability, obtained in blends

with *T. repens* and *T. pratense*, also applies when it is used in a more complex grass-clover mixture in which competition with other grass species is important. In this experiment, it was possible to delay the typical change in the second utilisation year, (where a sward dominated by *L. perenne* becomes a sward substituted by other grasses - a process usually occurring in complex mixtures created for two and more utilisation years) (Suter *et al.*, 2004), by the use of the 'new' more competitive and more persistent *L. perenne* varieties. The different proportions of the high-quality species *L. perenne* may have an effect on the forage quality of the mixtures. Because *L. perenne* produces better silage than many other grass species (Wyss *et al.*, 2006), a high proportion of *L. perenne* in the herbage is preferred. Although a larger proportion of *L. perenne* is advantageous, the strong shift in species proportions caused by the use of 'new' varieties demonstrates that the equilibrium among species may be substantially changed. To avoid unwanted changes in the botanical composition of the mixed sward, the proportion of the individual components (species, varieties) in the seed mixture has to be adapted to the new, relative competitive abilities of these components.

## Conclusions

Progressively improving the set of recommended varieties by including the best new varieties improves the potential of grass-clover mixtures. The composition of grass-clover seed mixtures for leys has to be adapted periodically to the competitive ability of the new varieties.

## References

- Elgersma A., Nassiri M. and Schlepers H. (1998) Competition in Perennial Ryegrass-White Clover Mixtures under Cutting. 1. Dry-Matter Yield, Species Composition and Nitrogen Fixation. *Grass and Forage Science*, 53, 353-366.
- Kirwan L., Lüscher A., Sebastià M.T., Finn J.A., Collins R.P., Porqueddu C., Helgadóttir Á., Baadshaug O.H., Brophy C., Coran C., Dalmanndóttir S., Delgado I., Elgersma A., Fothergill M., Frankow-Lindberg B.E., Golinski P., Grieu P., Gustavsson A.M., Höglind M., Huguenin-Elie O., Iliadis C., Jørgensen M., Kadziulienė Z., Karyotis T., Lunnan T., Malengier M., Maltoni S., Meyer V., Nyfeler D., Nykänen-Kurki P., Parente G., Smit H.J., Thumm U. and Connolly J. (2007) Evenness Drives Consistent Diversity Effects in an Intensive Grassland System across 28 European Sites. *Journal of Ecology*, in Press.
- Lehmann J., Briner H.U. and Mosimann E. (1998) Rotklee- und Wiesenschwingelsorten in Prüfung. *Agrarforschung*, 5, 177-180.
- Lehmann J., Briner H.U., Mosimann E. and Chalet C. (2001) 71 Sorten von Englischem Raigras im Test. *Agrarforschung*, 8, 130-135.
- Lehmann J., Schubiger F.X., Briner H.U. and Mosimann E. (1997) Neue empfohlene Knäulgras- und Rohrschwingelsorten. *Agrarforschung*, 4, 251-254.
- Lüscher A. and Aeschlimann U. (2006) Effects of Elevated [CO<sub>2</sub>] and N Fertilization on Interspecific Interactions in Temperate Grassland Model Ecosystems. In: Nösberger J., Long S.P., Norby R.J., Stitt M., Hendrey G.R. and Blum H. (eds) *Managed Ecosystems and CO<sub>2</sub>*. *Ecological Studies*, Vol. 187, Springer, Berlin.
- Rochon J.J., Doyle C.J., Greef J.M., Hopkins A., Mollé G., Sitzia M., Scholefield D. and Smith C.J. (2004) Grazing legumes in Europe: a Review of their Status, Management, Benefits, Research Needs and Future Prospects. *Grass and Forage Science*, 59, 197-214.
- Suter D., Briner H.U., Jeangros B., Mosimann E. and Bertossa M. (2006) Liste der empfohlenen Sorten von Futterpflanzen 2007-2008. *Agrarforschung*, 13 (9), I-XVI.
- Suter D., Rosenberg E. and Mosimann E. (2004) Standardmischungen für den Futterbau, Revision 2005-2008. *Agrarforschung*, 11, 1-12.
- Wyss U. (2006) Silierbarkeit und Silagequalität von Gräsern und Leguminosen. *Agrarforschung*, 13, 442-447.
- Zanetti S., Hartwig U.A., van Kessel C., Lüscher A., Hebeisen T., Frehner M., Fischer B.U., Hendrey G.R., Blum H. and Nösberger J. (1997) Does Nitrogen Nutrition Restrict the CO<sub>2</sub> Response of Fertile Grassland Lacking Legumes? *Oecologia*, 112, 12-25.

## ***Senecio jacobaea* and management practice: What are the links?**

Suter M.<sup>1,2</sup>, Siegrist-Maag S.<sup>1</sup>, Connolly J.<sup>3</sup> and Lüscher A.<sup>1</sup>

<sup>1</sup> *Agroscope Reckenholz-Tänikon Research Station ART, Reckenholzstrasse 191, 8046 Zürich, Switzerland*

<sup>2</sup> *Swiss Grassland Society, Reckenholzstrasse 191, 8046 Zürich, Switzerland*

<sup>3</sup> *UCD School of Mathematical Sciences, Department of Statistics and Actuarial Science, University College Dublin, Dublin 4, Ireland*

### **Abstract**

*Senecio jacobaea* is a poisonous weed in grasslands of various countries (e.g. Great Britain, New Zealand, Central European states). The further spread of the species into farmland must be prevented. To assess the influence of management practice and site conditions on the occurrence of *S. jacobaea*, we conducted a survey in the northern and central part of Switzerland. Botanical assessments were carried out on grassland plots containing *S. jacobaea* and on neighbouring plots without *S. jacobaea*. For these plots, we analysed the soil nutrients and the details of management practice, such as type and intensity of management and fertiliser application. The most important factors influencing the occurrence of *S. jacobaea* were related to management: there was a considerably high risk for the occurrence of the species on parcels with low nitrogen fertilisation, continuous-extensive grazing (set stocking), and a high openness of the sward. *S. jacobaea* was not present in meadows cut more than twice per year. As an exception, with a high propagule pressure from the vicinity, *S. jacobaea* was found in intensively grazed pastures and in meadows of moderate management intensity (two cuts). We conclude that a long-term control of *S. jacobaea* can best be achieved by avoiding sward damage, by replacing continuous-extensive by rotational grazing, and by preventing the species' seed formation in the pasture and local vicinity.

Keywords: weed control, nitrogen applied, grazing, openness of sward, on-farm survey, case-control study, *Senecio jacobaea*

### **Introduction**

*Senecio jacobaea* L. (tansy ragwort) is a poisonous weed in grasslands of several countries (Schmidl, 1972, McEvoy *et al.*, 1993); the species contains pyrrolizidine-alkaloids that are toxic for cattle and other livestock (Duby, 1975). *S. jacobaea* is a biennial species that has a high potential to establish, disperse and persist. Each plant produces several thousand seeds per year (Wardle, 1987) which are partly dispersed by wind. Seed survival (up to 20 years) and germination rates (approx. 80%) are high (Crawley and Nachapong, 1985, Wardle, 1987). In Central Europe, *S. jacobaea* seems to have increased its dispersion in the last five years. The current discussion with regard to the increasing *S. jacobaea* abundance focuses on agri-environmental programs (e.g. CAP) or on the role of less intensive management due to economic pressure (Bosshard *et al.*, 2003). This paper presents data from a survey conducted in the northern and central part of Switzerland assessing the influence of management practice and site conditions on the occurrence of *S. jacobaea*. Our aim was to find a combination of conditions where the risk for the occurrence of *S. jacobaea* was either remarkably high or low. Such data will allow strategies to hinder the weed's development.

## Materials and methods

The survey covered areas in the Jura region and the Swiss Plateau/Prealps. Data was collected from a total of 62 parcels (farm management units) with *S. jacobaea* occurring in 32. The design of the survey followed a matched case-control study, a standard method in health studies (Agresti, 2002). At a particular location, usually two parcels were selected: one where *S. jacobaea* was present (cases) and one where it was not (controls). Both parcels had, as far as possible, similar environmental conditions, however, the management practice between them may have differed. In each parcel, we selected a representative plot of 5 x 5 m<sup>2</sup> in which all measurements were taken. We recorded the inclination and exposition and took a representative sample of the topsoil (10 cm deep) for the analysis of soil nutrients and soil texture (Agroscope FAL Reckenholz, 1999). A vegetation assessment established the percent cover of the species and the gaps in the sward (% openness: bare ground visible from above the sward). The farmers provided data on applied mineral and organic fertilisers (slurry, solid manure) which were used to calculate the amount of plant-available nitrogen applied per year. Furthermore, we registered the type of grassland management (mowing, rotational grazing, continuous grazing), changes in management intensity over the last 15 years (increase or decrease of fertiliser application, frequency of mowing or grazing), and also disturbances in the last 15 years (e.g. construction of drainage tubes).

The influence of the recorded parameters on the occurrence of *S. jacobaea* was analysed using multiple logistic regression, the response variable being the presence or absence of *S. jacobaea*. The variables were tested with forward selection, while the inclusion of a variable was assessed using the AICc (Burnham and Anderson, 2002). The approximate relative risk, the ratio of the probability of presence of the weed for two levels of an environmental variable, was calculated following Agresti (2002). The indicator species occurring in plots with or without *S. jacobaea*, respectively, were determined calculating the “Indicator value of species” (Ind-Val) (Dufrene and Legendre, 1997).

## Results and discussion

The most relevant factors for the occurrence of *S. jacobaea* were the amount of plant-available nitrogen applied, the openness of sward, and the type of management (continuous grazing *versus* mowing or rotational grazing, Table 1). Following the selection procedure, the further variables recorded were not relevant in explaining the presence/absence of *S. jacobaea*. Doubling the application of nitrogen to 100 kg ha<sup>-1</sup> yr<sup>-1</sup> reduced the risk for *S. jacobaea* occurrence approximately five-fold (0.19), which means that the species occurred less frequently on intensively fertilised grasslands. High nitrogen application and mowing frequency promote fast growing species such as *Lolium multiflorum* or *Dactylis glomerata* which resist frequent defoliation and are also strong competitors. In agreement, the indicator species in plots without *S. jacobaea* (Table 2) have their preferential habitat on fertile sites and also grow in intensively managed grassland (Dietl and Jorquera, 2003). The chance for *S. jacobaea* to germinate and establish under such conditions is strongly impaired (Crawley and Nachapong, 1985); in the present survey *S. jacobaea* was never found in meadows cut more than twice per year. As an exception, with a high propagule pressure from the vicinity, *S. jacobaea* was found in intensively grazed pastures and in meadows of moderate management intensity (two cuts). Thus, our data suggest that *S. jacobaea* should generally not occur under intensive grassland management.

Swards that had a high percentage of uncovered soil (> 25%) had a forty-fold greater risk for the occurrence of the species than swards with an openness of less than 25% (Table 1). This result is in agreement with other studies that found a greater *S. jacobaea* establishment on open sites than in dense swards (Crawley and Nachapong, 1985, McEvoy *et al.*, 1993). Gaps

in the vegetation often arise due to disturbance. In the present study, plots with a high openness had also a steeper incline ( $P < 0.001$ ). On steep sites there is an increased risk for sward damage be it by cattle grazing or by mechanical damage in the case of mown grassland. The resulting gaps provide suitable conditions for seed germination and plant establishment (Silvertown and Smith, 1989). The pioneer species *S. jacobaea*, with its high number of relatively small seeds, could considerably profit from this situation. In accordance, species such as *Sonchus asper* and *S. oleraceus*, which prefer disturbed sites, were indicator species for the plots with *S. jacobaea* (Table 2).

Table 1. Variables with significant effects on the occurrence of *S. jacobaea* (estimates of logistic regression and the calculated relative risk).

Variable	Regression estimate	Relative risk (compared to the intercept)	P-value
Intercept †	-1.509		
Nitrogen-applied	-0.033	0.19 ‡	0.008
Openness: High (> 25%)	3.696	40.31	0.005
Rotational grazing vs mowing	-0.055	0.95	0.953
Continuous grazing vs mowing	2.447	11.56	0.017
R <sup>2</sup>			0.658

† The intercept represents grassland that was mown, received available nitrogen of 50 kg ha<sup>-1</sup> yr<sup>-1</sup>, and had a low openness of sward ( $\leq 25\%$ )

‡ Relative risk for applied nitrogen of 100 kg ha<sup>-1</sup> yr<sup>-1</sup>

Table 2. Indicator species for the groups with and without *S. jacobaea* (Sj) and their Ind-Val (Indicator value of species). Only species with  $P < 0.01$  are presented.

Indicator species	Frequency of species' occurrence		Mean cover of species (%)		Ind-Val	P-value
	Plots with Sj <sup>†</sup>	Plots without Sj <sup>‡</sup>	Plots with Sj <sup>†</sup>	Plots without Sj <sup>‡</sup>		
Group with <i>S. jacobaea</i> :						
<i>Senecio jacobaea</i>	32	0	3.9	0.0	1.00	< 0.001
<i>Brachypodium pinnatum</i>	10	0	2.6	0.0	0.31	< 0.001
<i>Prunella vulgaris</i>	19	5	0.6	0.1	0.49	< 0.001
<i>Lathyrus pratensis</i>	14	3	0.3	0.0	0.40	0.001
<i>Sanguisorba minor</i>	9	0	1.2	0.0	0.28	0.001
<i>Bromus erectus subsp. erectus</i>	9	0	3.4	0.0	0.28	0.002
<i>Festuca rubra</i>	25	10	10.2	8.5	0.43	0.003
<i>Sonchus oleraceus</i>	8	0	0.3	0.0	0.25	0.003
<i>Medicago lupulina</i>	9	1	0.2	0.0	0.26	0.004
<i>Sonchus asper</i>	7	0	0.1	0.0	0.22	0.006
<i>Lotus corniculatus</i>	16	6	0.7	0.2	0.39	0.007
<i>Ononis repens</i>	6	0	0.2	0.0	0.19	0.008
<i>Thymus serpyllum aggr.</i>	7	0	0.2	0.0	0.22	0.009
Group without <i>S. jacobaea</i> :						
<i>Trifolium repens</i>	26	28	3.1	8.8	0.69	< 0.001
<i>Rumex obtusifolius</i>	6	20	0.1	1.0	0.59	< 0.001
<i>Heracleum sphondylium</i>	1	10	0.0	1.0	0.33	< 0.001
<i>Taraxacum officinale aggr.</i>	25	27	2.4	6.1	0.64	0.003
<i>Lolium multiflorum</i>	7	14	1.8	13.8	0.41	0.003

† No. of plots = 32; ‡ No. of plots = 30

A further factor influencing *S. jacobaea* was the type of management. Plots that were under continuous-extensive grazing (set stocking) had an approximately eleven-fold greater risk for the occurrence of *S. jacobaea* compared to mown grassland, while rotational grazing did not show significant differences in risks compared to mowing (Table 1). Parcels under continuous-extensive grazing are often unevenly grazed due to the selective behaviour of

cattle. The over-grazed patches show gaps in the sward where *S. jacobaea* seeds can germinate and establish, while the under-grazed patches provide conditions where *S. jacobaea* can complete its growth. Established individuals of *S. jacobaea* are no longer grazed, which is a considerable advantage for growth and reproduction (Noy-Meir *et al.*, 1989). The species can finalise its lifecycle, produce seeds and will further spread on the parcel. Thus, *S. jacobaea* takes advantage of both the under- and the overgrazed parts in continuously, unevenly grazed grasslands. We conclude that extensively, unevenly grazed pastures and gaps in the sward strongly favour *S. jacobaea*. Often, continuous grazing is established on steep sites, where mowing is labour-intensive, and where no maintenance of parcels takes place due to economical constraints. Combined with low fertiliser input, such areas are highly susceptible to new infestations of *S. jacobaea*.

## Conclusions

Our results suggest that a further spread of *S. jacobaea* in farmland might be prevented by increasing the management intensity. This is hardly possible on many sites where *S. jacobaea* occurs, due to the limitations of topography, soil conditions or other factors. However, our data also show that the openness of the sward and the grazing system similarly contributed to the increase in *S. jacobaea* occurrence. We therefore suggest preventing sward damage as much as possible and maintaining the parcels carefully. Preventing sward damage can be achieved by replacing continuous-extensive by rotational grazing or by adjusting grazing pressure to reduce over-grazing. The maintenance of parcels includes the cutting of weeds to reduce seed formation. The control of *S. jacobaea* in agricultural grasslands should be achieved by inhibiting establishment in the pastures and meadows and by preventing seed formation in the local environment.

## Acknowledgments

The project was supported by the Swiss Federal Office for Agriculture FOAG.

## References

- Agresti A. (2002) *Categorical data analysis*, 2nd edn. New York, US: Wiley.
- Agroscope FAL Reckenholz (1999) *Referenzmethoden der Eidgenössischen landwirtschaftlichen Forschungsanstalten, Band 1: Bodenuntersuchung zur Düngeberatung*. Zürich, Schweiz: Eidg. Forschungsanstalten FAL-RAC-FAW.
- Bosshard A., Joshi J., Lüscher A. and Schaffner U. (2003) Jakobs- und andere Kreuzkraut-Arten: eine Standortbestimmung. *Agrarforschung*, 10, 231-235.
- Burnham K.P. and Anderson D.R. (2002) *Model selection and multimodel inference*, 2nd edn. New York, US: Springer.
- Crawley M.J. and Nachapong M. (1985) The establishment of seedlings from primary and regrowth seeds of ragwort (*Senecio jacobaea*). *Journal of Ecology*, 73, 255-262.
- Dietl W. and Jorquera M. (2003) *Wiesen- und Alpenpflanzen*. Zürich, Schweiz: Agroscope FAL Reckenholz.
- Duby G.D. (1975) Tansy ragwort: a toxic threat to livestock. *Modern Veterinary Practice*, 56, 185-188.
- Dufrêne M. and Legendre P. (1997) Species assemblages and indicator species: The need for a flexible asymmetrical approach. *Ecological Monographs*, 67, 345-366.
- McEvoy P.B., Rudd N.T., Cox C.S. and Huso M. (1993) Disturbance, competition, and herbivory effects on ragwort *Senecio jacobaea* populations. *Ecological Monographs*, 63, 55-75.
- Noy-Meir I., Gutman M. and Kaplan Y. (1989) Responses of mediterranean grassland plants to grazing and protection. *Journal of Ecology*, 77, 290-310.
- Schmidl L. (1972) Biology and control of ragwort, *Senecio jacobaea* L., in Victoria, Australia. *Weed Research*, Silvertown J. and Smith B. (1989) Mapping the microenvironment for seed germination in the field. *Annals of Botany*, 63, 163-168.
- Wardle D.A. (1987) The ecology of ragwort (*Senecio jacobaea* L.) - A review. *New Zealand Journal of Ecology*, 10, 67-76.



# Elevated atmospheric CO<sub>2</sub> stimulates N<sub>2</sub>O emissions in a long-term FACE experiment

Kammann C., Müller C., Grünhage L. and Jäger H.-J.

*Dept. of Plant Ecology, University of Giessen, 35392 Giessen, Germany*

## Abstract

To evaluate climate forcing under increasing atmospheric CO<sub>2</sub> concentrations, feedback effects on greenhouse gases such as nitrous oxide (N<sub>2</sub>O) with a high global warming potential must be included to determine if an ecosystem becomes a sink or a source for greenhouse gases. In the long-term Giessen-FACE (**F**ree **A**ir **C**O<sub>2</sub> **E**nrichment) experiment in low-N-fertilized permanent grassland, N<sub>2</sub>O fluxes were measured continuously over more than 8 years. N<sub>2</sub>O emissions were considerably stimulated by elevated CO<sub>2</sub>. The stimulation occurred mainly in the summer/autumn period and not as expected shortly after N-fertilization in spring. Averaged over the entire FACE duration (May 1998 – December 2006), 543 kg of additional CO<sub>2</sub>-equivalents ha<sup>-1</sup> a<sup>-1</sup> were released as N<sub>2</sub>O under elevated compared to ambient CO<sub>2</sub>, respectively. Thus, the CO<sub>2</sub> sequestration potential of ecosystems under future elevated CO<sub>2</sub> concentrations may be overestimated if feedback effects on N<sub>2</sub>O emissions are ignored.

Keywords: elevated CO<sub>2</sub> (FACE), N<sub>2</sub>O emissions, global warming potential (GWP), grassland

## Introduction

Nitrous oxide (N<sub>2</sub>O) is a potent greenhouse gas with a global warming potential (GWP) of 296 times that of CO<sub>2</sub> on a 100-yr time scale. It is predominantly produced in oxic and anoxic soil microsites through microbial nitrification and denitrification, respectively (Granli and Bøckmann, 1994). The main cause for the increase of the atmospheric mixing ratio of N<sub>2</sub>O from 270 ppb to 319 ppb over the last 255 years is the supply of available N to soils via organic and inorganic amendments (IPCC, 2007). At the same time, the atmospheric CO<sub>2</sub> concentration increased by 35% (IPCC, 2007). Elevated CO<sub>2</sub> enhances plant growth, transfer of labile organic C to soils, and soil moisture due to improved plant water use efficiency (WUE), especially in grasslands (Morgan *et al.*, 2004). Stimulatory effects of organic C inputs and higher soil moisture on denitrification are well known (Ineson *et al.*, 1998; Baggs *et al.*, 2003). Few studies investigated N<sub>2</sub>O emissions under elevated CO<sub>2</sub>, mostly for time periods <1 year. Results showed that N<sub>2</sub>O emissions increased (Arnone *et al.*, 1998; Ineson *et al.*, 1998; Baggs *et al.*, 2003), decreased (Pleijel *et al.*, 1998) or remained unchanged (Hungate *et al.*, 1997; Phillips *et al.*, 2001; Mosier *et al.*, 2002) under elevated CO<sub>2</sub>. To assess the effect of elevated CO<sub>2</sub> on N<sub>2</sub>O emissions over the wide range of climatic conditions at a site, frequent measurements over several years are pivotal (Mosier *et al.*, 2002). We measured N<sub>2</sub>O fluxes in the Giessen-FACE study on permanent grassland over more than 8 years.

## Materials and methods

The University of Giessen Free air Carbon dioxide Enrichment study (Giessen-FACE; see Jäger *et al.*, 2003) started in May 1998 in a wet permanent grassland (*Arrhenatherum elatioris* Br.-Bl.). Since 1996 the plots are fertilized with 40 kg N ha<sup>-1</sup> a<sup>-1</sup> as granular CaNH<sub>4</sub>(NO<sub>3</sub>)<sub>3</sub> around mid-April and mown twice each year. Three of the six 8-m-diameter ring plots receive a moderate CO<sub>2</sub> enrichment (=E: +20% above ambient CO<sub>2</sub> (=A)) year-round during daylight

hours. Climatic conditions, soil moisture and temperature are recorded continuously at the site; both were not affected by elevated CO<sub>2</sub> (Kammann *et al.*, 2005). N<sub>2</sub>O flux measurements (Kammann *et al.*, 1998) were performed with maxi-chambers (1 m diameter) in 3 replicates per plot 1-3 times weekly. Measurements were carried out prior to (Mar. – Oct. 1997; Feb. – Apr. 1998) and after the FACE start (May 1998 – Dec. 2006). Gas samples were analyzed within 24 h after collection on a gas chromatograph (HP6890; Kammann *et al.*, 1998) and fluxes were calculated by linear regression (4 samples). N<sub>2</sub>O flux periods were pre-defined as follows: (1) off-season, usually without active plant growth (Nov. – Mar., period 1); (2) spring after N fertilization (Apr. – May, period 2) and (3) remaining growth period with less active plant growth (Jun. – Oct., period 3). For calculation of N<sub>2</sub>O emission sums across years and periods, N<sub>2</sub>O fluxes were linearly interpolated on a daily basis using ModelMaker 3.0. N<sub>2</sub>O emission sums were tested for significant differences due to elevated CO<sub>2</sub> by t-test or mixed model analyses (SPSS 12.0.1); sums were log-transformed if necessary. P values <0.1 are reported as significant (Filion *et al.*, 2000).

## Results and discussion

Over the entire experimental FACE duration (May 1998 – December 2006) highest N<sub>2</sub>O emissions were observed in the years 1998 – 2000 (Figure 1A). In the first year 1998, N<sub>2</sub>O emissions were significantly increased by elevated CO<sub>2</sub> (P=0.026; t-test) whereas prior to the FACE start, E-and A-N<sub>2</sub>O emissions were not significantly different. Over the first 2.67 years (1998 – 2000), however, the large stimulation was only significant in June to October (P = 0.075, t-test; Table 1) due to E plot heterogeneity. During the first FACE years (1998 – 2000), N<sub>2</sub>O-fluxes were generally larger than prior to 1998 (Kammann *et al.*, 1998) or during subsequent FACE years (2001 – 2006). In the subsequent 6 FACE years, the response of N<sub>2</sub>O fluxes to elevated CO<sub>2</sub> became more homogeneous (Figure 1) with the largest and most significant stimulation still present in June-October (Figure 1B; Table 1). Regardless how the N<sub>2</sub>O emissions during the recent 6 FACE years were averaged (2001 – 2006, or 2002, 2003 to 2004 – 2006), the E-emission sum during period 3 was always significantly larger than the A sum (P<0.05, t-test). Over the entire FACE experiment, this period contributed the largest proportion to the N<sub>2</sub>O flux increases under elevated CO<sub>2</sub> in absolute (Figure 1B) as well as in relative terms (E: 63%; A: 38%).

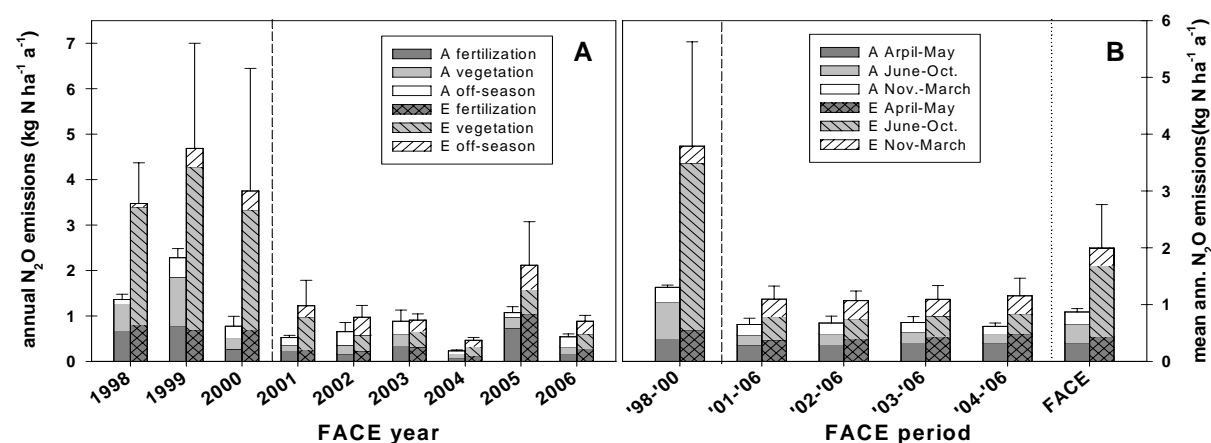

Figure 1. Integrated N<sub>2</sub>O emission sums under ambient and elevated CO<sub>2</sub> (left and right of tick, respectively) cumulated over periods 1-3 (see "Methods"). (A) Annual emissions; (B) Emissions averaged over different years with emphasis on the later experimental years. Sums in B were divided by the number of years of the respective period to give annual means. Note that the start of the CO<sub>2</sub> enrichment was 1<sup>st</sup> May 1998, i.e. 1998 = 0.67 years.

Based on theory and results (e.g. Pleijel *et al.*, 1998; Hungate *et al.*, 1997; Barnard *et al.*, 2005), a decline of N<sub>2</sub>O emissions during period 3 had been expected rather than an increase, due to a more severe competition of growing plant biomass for mineral N. Indeed, an increase of the aboveground yield (Kammann *et al.*, 2005) and of the root biomass was observed under elevated CO<sub>2</sub>. On the other hand, we anticipated a rise of N<sub>2</sub>O emissions when mineral-N was more abundant after N-fertilizer application as observed elsewhere (Ineson *et al.*, 1998; Baggs *et al.*, 2003). In our low-N-fertilized grassland, N<sub>2</sub>O emissions were never significantly stimulated during the "fertilization" period in April-May (Figure 1B; Tables 1, 2).

Table 1. Results of Mixed Model analyses of annual N<sub>2</sub>O emission sums of different time periods within a year as defined in "Methods" with the factors "year" (repeated factor) and "CO<sub>2</sub> treatment" for the first 2.67 FACE years, the subsequent 6 FACE years, and the entire 8.67 FACE years.

Time period	Factor	1998* - 2000		2001 - 2006		1998* - 2006	
		F value	P value	F value	P value	F value	P value
<b>April – May</b> (period 2, fertilisat.)	CO <sub>2</sub>	1.01	0.371	1.79	0.211	2.61	0.128
	Year	2.86	0.093	14.52	0.000	11.68	0.000
<b>June – October</b> (period 3, growth)	CO <sub>2</sub>	5.13	<b>0.088</b>	19.85	<b>0.002</b>	12.32	<b>0.006</b>
	Year	7.09	0.021	2.20	0.088	7.79	0.000
<b>November – March</b> (period 1, off-seas.)	CO <sub>2</sub>	0.01	0.912	3.69	<b>0.088</b>	2.02	0.183
	Year	10.85	0.002	4.83	0.003	6.44	0.000
<b>June – March</b> (periods 2 + 3)	CO <sub>2</sub>	3.73	0.127	12.93	<b>0.007</b>	10.07	<b>0.011</b>
	Year	8.50	0.017	3.95	0.009	7.84	0.000
<b>Entire years</b> (all periods)	CO <sub>2</sub>	4.19	0.111	9.97	<b>0.012</b>	9.15	<b>0.013</b>
	Year	8.26	0.014	9.86	0.000	11.81	0.000

\*1998: CO<sub>2</sub> enrichment started on 1<sup>st</sup> May 1998, therefore period 1 and part of period 2 in 1998 are incomplete.

Table 2: N<sub>2</sub>O emission sums under ambient (A) and elevated (E) CO<sub>2</sub> calculated for various time periods under CO<sub>2</sub> enrichment (1998\*: Start in May); in brackets: Amount in CO<sub>2</sub>-equivalents calculated with a GWP of 296. GWP = Global warming potential (100-yr time horizon), dGWP/a = mean annual GWP increase in N<sub>2</sub>O emissions under elevated CO<sub>2</sub>. Data were split into two sets of "first" and "later" FACE years to separate a possible CO<sub>2</sub>-step increase effect, and to show that averaging the CO<sub>2</sub>-induced N<sub>2</sub>O emission increase over different periods during the later FACE years resulted in almost identical annual GWP increases.

FACE years	E ± se (GWP)	A ± se (GWP)	E/A	E-A, ΔGWP	dGWP/a
	kg N <sub>2</sub> O-N ha <sup>-1</sup> (kg CO <sub>2</sub> -eq. ha <sup>-1</sup> )			(kg CO <sub>2</sub> -equivalents ha <sup>-1</sup> )	
1998* - 2000	11.4 ± 5.5 (5288)	3.9 ± 0.1 (1821)	2.9	3467.9	1298.2
1998* - 2001	12.6 ± 6.1 (5859)	4.4 ± 0.1 (2064)	2.8	3794.3	1033.5
2001 - 2006	6.6 ± 1.4 (3057)	3.9 ± 0.6 (1819)	1.7	1238.6	206.4
2002 - 2006	5.3 ± 0.9 (2487)	3.4 ± 0.6 (1575)	1.6	912.2	182.4
2003 - 2006	4.4 ± 1.0 (2034)	2.7 ± 0.4 (1270)	1.6	764.2	191.0
2004 - 2006	3.5 ± 0.9 (1612)	1.8 ± 0.2 (859)	1.9	753.3	251.1
FACE ('98* - '06)	17.9 ± 6.9 (8346)	7.8 ± 0.5 (3639)	2.3	4706.5	542.8

During the off-season (Nov. – Mar.) at higher soil moistures we expected a moderate N<sub>2</sub>O emission rise under elevated CO<sub>2</sub> due to mineralization of increased plant and microbial biomass (Arnone *et al.*, 1998; Phillips *et al.*, 2001). Indeed, E-N<sub>2</sub>O emissions increased significantly by +60% during the later, but not during the first FACE years (Table 1). Over the entire FACE experiment and the later FACE years, the CO<sub>2</sub> effect on N<sub>2</sub>O emission sums was significant, however, not during the first years (Table 1). This pattern may have been due to a CO<sub>2</sub> step increase effect (Klironomos *et al.*, 2005) although the Giessen-FACE operates with the most moderate CO<sub>2</sub> concentration increase worldwide. On the other hand, the larger-

than-usual N<sub>2</sub>O fluxes and E-plot heterogeneity during the years 1998 - 2000 may also have been related to the loss of organic C and N at the site (Kaupe *et al.*, this issue).

## Conclusions

A robust, significant stimulation of N<sub>2</sub>O emissions under elevated CO<sub>2</sub> was observed in the (to our knowledge) longest continuous N<sub>2</sub>O-flux record under CO<sub>2</sub> enrichment worldwide. A shorter study of only 3-4 years duration would have missed the stimulation under (likely) new equilibrium conditions, a plea for more long-term studies.

N<sub>2</sub>O emissions more than doubled under elevated CO<sub>2</sub> over the entire experiment (Table 2). Calculations of long-term C-storage in soils therefore must include stimulatory effects of elevated CO<sub>2</sub> on N<sub>2</sub>O (and CH<sub>4</sub>) to assess the true GWP-(i.e. CO<sub>2</sub>)-sink strength.

Stimulation patterns were unexpected, N<sub>2</sub>O emission increases occurred dominantly during the growth period under N-limiting conditions rather than after N fertilization, indicating an insufficient process understanding.

A positive feedback of the atmospheric CO<sub>2</sub> increase on N<sub>2</sub>O emissions as observed here may accelerate global warming if it operates at larger spatial scales worldwide, emphasizing the need to include GHG flux measurements in elevated-CO<sub>2</sub> studies.

## References

- Arnone JA, and Bohlen PJ (1998) Stimulated N<sub>2</sub>O flux from intact grassland monoliths after two growing seasons under elevated atmospheric CO<sub>2</sub> *Oecologia*, 116, 331-335.
- Baggs EM, Richter M, Hartwig UA and Cadisch G (2003) Nitrous oxide emissions from grass swards during the eighth year of elevated atmospheric pCO<sub>2</sub> (Swiss FACE). *Global Change Biology*, 9, 1214-1222.
- Barnard R, Leadley PW and Hungate BA (2005) Global change, nitrification, and denitrification: A review. *Global Biogeochemical Cycles*, 19, GB1007, doi:10.1029/2004GB002282
- Filion M, Dutilleul P, Potvin C (2000) Optimum experimental design for Free-Air Carbon dioxide Enrichment (FACE) studies. *Global Change Biology*, 6, 843-854.
- Granli T and Bøckmann OC (1994) Nitrous oxide from agriculture. *Norwegian Journal of Agricultural Sciences*, Supplement No. 12, 1-128.
- Hungate BA, Lund CP, Pearson HL and Chapin FS. Elevated CO<sub>2</sub> and nutrient addition alter soil N cycling and N trace gas fluxes with early season wet-up in a California annual grassland. *Biogeochemistry*, 37, 89-109.
- Ineson P, Coward PA and Hartwig UA (1998) Soil gas fluxes of N<sub>2</sub>O, CH<sub>4</sub> and CO<sub>2</sub> beneath *Lolium perenne* under elevated CO<sub>2</sub>: The Swiss free air carbon dioxide enrichment experiment. *Plant and Soil*, 198, 89-95.
- IPCC: Alley R, Berntsen T, *et al.* (2007) *Climate Change 2007: The Physical Science Basis - Summary for Policymakers*. 21 pp.
- Jäger HJ, Schmidt SW, Kammann C, Grünhage L, Müller C and Hanewald K (2003) The University of Giessen Free-Air Carbon Dioxide Enrichment Study: Description of the experimental site and of a new enrichment system. *Journal of Applied Botany*, 77, 117-127.
- Kammann C, Grünhage L, Müller C, Jacobi S and Jäger HJ (1998) Seasonal variability and mitigation options for N<sub>2</sub>O emissions from differently managed grasslands. *Environmental Pollution*, 102, S1, 179-186.
- Kammann C, Grünhage L, Grütters U, Janze S and Jäger HJ (2005) Response of aboveground grassland biomass and soil moisture to moderate long-term CO<sub>2</sub> enrichment. *Basic and Applied Ecology*, 6, 351-365.
- Klironomos JN, Allen MF, Rillig MC, Piotrowski J, Makvandi-Nejad S, Wolfe BE and Powell JR (2005) Abrupt rise in atmospheric CO<sub>2</sub> overestimates community response in a model plant-soil system. *Nature*, 433, 621-624.
- Morgan JA, Pataki DE, Körner C, *et al.* (2004) Water relations in grassland and desert ecosystems exposed to elevated atmospheric CO<sub>2</sub>. *Oecologia*, 140, 11-25.
- Mosier AR, Morgan JA, King JY, LeCain D and Milchunas DG (2002) Soil-atmosphere exchange of CH<sub>4</sub>, CO<sub>2</sub>, NO<sub>x</sub>, and N<sub>2</sub>O in the Colorado shortgrass steppe under elevated CO<sub>2</sub>. *Plant and Soil*, 240, 201-211.
- Phillips RL, Whalen SC and Schlesinger WH (2001) Influence of atmospheric CO<sub>2</sub> enrichment on nitrous oxide flux in a temperate forest ecosystem. *Global Biogeochemical Cycles*, 15, 741-752.
- Pleijel H, Sild J, Danielsson H and Klemetsson L (1998) Nitrous oxide emissions from a wheat field in response to elevated carbon dioxide concentration and open-top chamber enclosure. *Environmental Pollution*, 102, 167-171.

# Microclimatic effects on assimilation rate of a C4 species at the limit of its geographical distribution

Kostopoulou P. and Noitsakis B.

*Faculty of Forestry and Natural Environment, Aristotle University of Thessaloniki, 54 124 Thessaloniki, Greece*

## Abstract

The influence of the microclimate on the assimilation capacity of *Elymus hispidus* (C3 species) and *Cynodon dactylon* (C4 species), occurring naturally in a grassland of North-western Macedonia (21°46'E, 40°25'N), Greece, was studied. Maximum daytime temperature, relative humidity and vapour pressure deficit, as well as the assimilation rate at noon were measured at seven-day intervals during the dry period. The C4 photosynthetic rate was found to be less affected by the maximum daytime temperature, while the two photosynthetic pathways responded similarly under the change of relative humidity and vapour pressure deficit. The competitive advantage of C4 over C3 species seems to be maintained, even though to a lesser extent, at the limit of the C4 species geographical distribution.

Keywords: microclimate, C3 species, C4 species

## Introduction

Differences in the physiology between C3 and C4 photosynthetic pathways are reflected to the way they respond to environmental conditions. Temperature, light and humidity are among the most important factors controlling the relative efficiency of these two photosynthetic cycles. C4 species are recognised as more efficient in using high light intensities than C3 species and the latter are expected to be more efficient under lower temperatures in relation to C4 species (Mohr and Schopfer, 1995).

It is now clear that even species following the same photosynthetic pathway may have different demands as far as climatic conditions are concerned. Teeri and Stowe (1976) were the first to show the occurrence of a close relationship between the climatic parameters and the relative abundance of C3 and C4 species. Today, there is increasing evidence that the relative abundance of C4 species in an area is strongly correlated to the minimum daytime temperature during the growing season, at least for the C4 species of the *Poaceae* and *Cyperaceae* families (Collatz *et al.*, 1998). On the other hand, the hypothesis that the existence of C4 species is almost always related with drought conditions is now under revision (Machado and Paulsen, 2001, Koch *et al.*, 2004). In grassland ecosystems, which at least seasonally suffer from water stress, recent data show that the performance of C4 grasses is strongly related to the mean annual rainfall, as well as, to the amount of rainfall occurring during the growing season (Epstein *et al.*, 1997, Yang *et al.*, 1998). Consequently, it seems more possible that the C4 performance relies both on temperature and soil water content. The aim of this paper was to investigate the photosynthetic performance of a C4 species at the margin of its geographical distribution.

## Materials and methods

The experiment was carried out in a natural grassland of Ptolemais basin, in Northwestern Greece (21°46'E, 40°25'N) at 723m altitude. The climate of the area is characterized as typical semi-arid Mediterranean to temperate. According to meteorological data of the last 55 years the average maximum temperature (observed in July and August) is 29.3°C, while the minimum is -2.1°C (in January). The relative humidity during the wet-cool and the dry-hot season is 70-80% and 50-60% respectively. During the dry season (from June to August) the mean rainfall in the area is 30-35 mm and the mean photosynthetic photon flux density value (PPFD) around noon 2131  $\mu\text{mol m}^{-2} \text{s}^{-1}$ . Under these climatic data, the photosynthetic performance of two species, belonging to the *Poaceae* family, *Elymus hispidus* (Opiz) Melderis (C3) and *Cynodon dactylon* (L.) Pers (C4) was studied.

Measurements were conducted every seven days during the dry season (June and July) of 2005. At each measurement five fully expanded, mature leaves of each species were chosen in a completely random way at noon (14:00) in order to measure the assimilation rate ( $A$ ,  $\mu\text{mol m}^{-2} \text{s}^{-1}$ ), using a portable photosynthesis system. At the same time a microclimatic sensor was used for the measurement of atmospheric temperature (°C) and relative humidity (%). Vapor pressure deficit (VPD, kPa) was calculated according to Brenner (1996).

## Results and discussion

*Elymus hispidus* and *Cynodon dactylon*, following different photosynthetic cycles, apparently have different phenology in the studied area. *Elymus hispidus* appears in the grassland in early April and dries out in the middle of July, while *Cynodon dactylon* makes its appearance in early June and carries on until August (Figure 1). This different phenology results in the co-occurrence of these species in the grassland for two months that correspond to the beginning of the dry period.

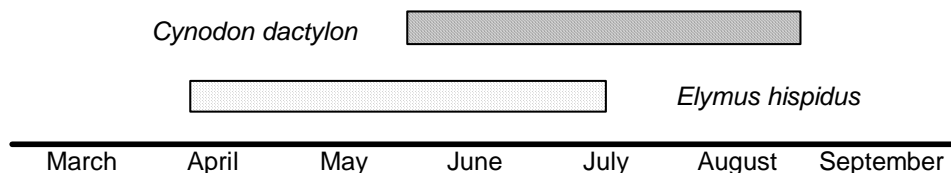

Figure 1. Lifespan of *Elymus hispidus* (C3) and *Cynodon dactylon* (C4) in the studied area.

The microclimate of the area is characterized by relatively low temperatures at night and early in the morning, which sometimes are lower than 10°C, even in the summer months and by relatively high temperatures at noon. In addition, the photosynthetic photon flux density values observed in the area are considered high for the demands of C3 species and quite satisfying for the demands of C4 species (Mohr and Schopfer, 1995). These microclimatic conditions show that the C4 species is at the limit of its geographical distribution, since C4 species appear in areas with minimum temperature of summer months higher than 7.5°C (this temperature corresponds to a latitude of 50°N) (Pyankov *et al.*, 2000). C4 species are also referred to demand a maximum temperature of 22°C (average temperature of the hottest month) (Collatz *et al.*, 1998).

The assimilation rate of both species responds in a similar manner in relation to relative humidity and VPD (Figure 2), with the assimilation rate of the C4 species being only slightly higher (by 1.0  $\mu\text{mol m}^{-2} \text{s}^{-1}$ ) when the VPD of the atmosphere shows values higher than 3.0 kPa. On the other hand, the maximum daytime temperature seems to affect less the

assimilation rate of the C4 species, while at temperatures higher than 25°C the photosynthetic rate of the C3 species is significantly reduced (Figure 2).

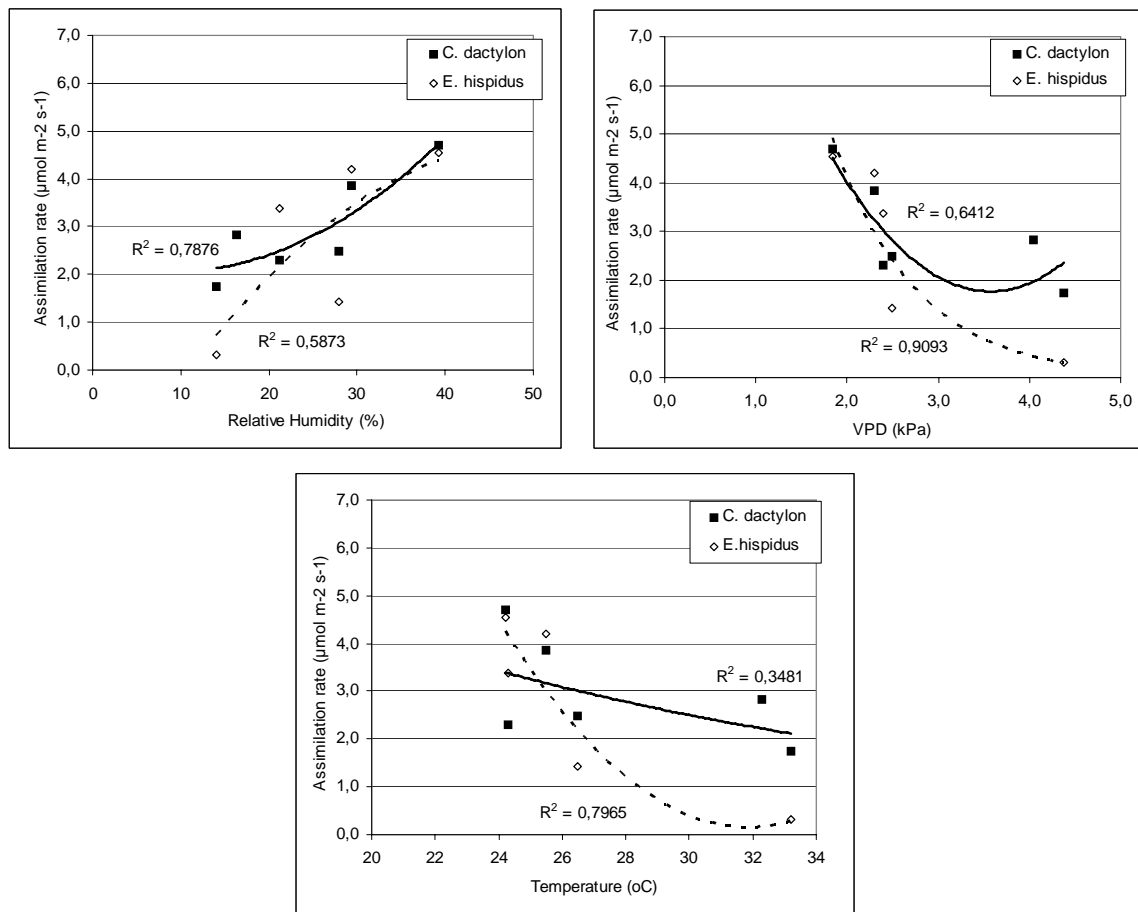

Figure 2. Relationship between assimilation rate and relative humidity, vapour pressure deficit (VPD) and maximum daytime temperature of *Elymus hispidus* (C3) and *Cynodon dactylon* (C4).

The fact that both species seem to respond similarly under the influence of increasing VPD and differently under the influence of temperature, shows that the limiting factor on their performance is not water shortage, as expected, but optimum temperature conditions. Although C4 species are considered to perform better under higher temperatures, having a temperature optimum of about 30-35°C (Mohr and Schopfer, 1995), in this case the assimilation rate of the C4 *Cynodon dactylon* is slightly reduced under higher temperatures and shows similar values to the assimilation of the C3 species. Consequently, the maximum daytime temperature seems not to be a key factor in the photosynthetic performance of this C4 species. On the contrary, the low values of temperature observed early in the morning in this area seem to play a more important role to the C4 photosynthetic performance. Nevertheless, even under these adverse microclimatic conditions, the competitive advantage of C4 over C3 species seems to be maintained, even though to a lesser extent, at the limit of the C4 species geographical distribution.

## Conclusions

At the limit of its geographical distribution C4 species *Cynodon dactylon* seems to maintain, though to a lesser extent, its competitive advantage in terms of photosynthetic performance over the C3 species *Elymus hispidus*, being less influenced by the maximum daytime temperature.

## References

- Brenner A.J. (1996) Microclimate modifications in Agroforestry. In: Ong C.K. and Huxley P. (eds) Tree-Crop Interactions. CAB International, Oxon, pp. 159-188.
- Collatz G.J., Berry J.A. and Clark J.S. (1998) Effects of climate and atmospheric CO<sub>2</sub> partial pressure on the global distribution of C4 grasses: present, past, and future. *Oecologia*, 114, 441-454.
- Epstein H.E., Lauenroth W.K., Burke I.C. and Coffin D.P. (1997) Productivity patterns of C3 and C4 functional types in the U.S. Great Plains. *Ecology*, 78, 722-731.
- Koch P.L., Diffenbaugh N.S. and Hoppe K.A. (2004) The effects of late Quaternary climate and pCO<sub>2</sub> change on C4 plant abundance in the south-central United States. *Palaeogeography, Palaeoclimatology, Palaeoecology*, 207, 331– 357.
- Machado S. and Paulsen G.M. (2001) Combined effects of drought and high temperature on water relations of wheat and sorghum. *Plant and Soil*, 233, 179-187.
- Mohr H. and Schopfer P. (1995) Plant Physiology. Springer-Verlag, Berlin, 629 pp.
- Pyankov V.I., Gunin P.D., Tsoog S. and Black C.C. (2000) C4 plants in the vegetation of Mongolia: their natural occurrence and geographical distribution in relation to climate. *Oecologia*, 123, 15-31.
- Teeri J.A. and Stowe L.G. (1976) Climatic patterns and the distribution of C4 grasses in North America. *Oecologia*, 23, 1-12.
- Yang L., Wylie B.K., Tieszen L.L. and Reed B.C. (1998) An analysis of relationships among climate forcing and time-integrated NDVI of grasslands over the U.S. northern and central Great Plains. *Remote Sensing of the Environment*, 65, 25-37.



# Allelopathic activity of some grass species towards *Phleum pratense* L.

Lipińska H. and Harkot W.

Agricultural University, Department of Grassland and Green Forming, Lublin, Poland

## Abstract

The allelopathic activity of *Festuca arundinacea*, *Lolium multiflorum*, *L. perenne* and *Poa pratensis* towards *Phleum pratense* was evaluated using the “density dependent phytotoxicity model”. The allelopathic properties of donor grasses were assessed studying the effect of blastocolines released from their seeds and seedlings on the early development of *Ph. pratense* (acceptor). The results revealed that the early development of *Ph. pratense* was differentiated subject to a species, age and density of donor plants as well as acceptor plants density. The chemical interference between the plants may be used to determine the compatibility of different species in pasture and meadows mixtures. Knowledge on the species allelopathic activities offers a potentiality for the practical biodiversity enrichment in grassland

Keywords: allelopathy, *density dependent phytotoxicity model*, grasses

## Introduction

In the multi-species plant associations of grasslands, plant growth and development is modified by a number of habitat factors as well as physical and chemical processes occurring due to neighborhood of other species (Bertin *et al.*, 2003; Lipińska and Harkot, 2005). Recently, much concern has been given to the allelopathic interactions of plants, due to which some species withdraw, the new ones appear and the number of others increases. These interactions occur as early as the seed germination starts and persist throughout the plant growth and developmental stages in the plant association (Rice, 1984). The allelopathic substances presence was recorded in both, the above ground and underground parts of plants. The compounds were also identified in seeds (Rice, 1984). On grasslands, the allelopathic substances released from the germinating seeds of some species may affect negatively the germination, early development and installation of seedlings of the other species (Emeterio *et al.*, 2003). Therefore, this vital effect must be taken into account when new grasslands are set up or improved applying the undersow to enrich their species composition. In Poland, *Phleum pratense* is a common species sown on pasture meadows.

The objective of the present investigations was to evaluate a *Ph. pratense* response to the allelocompounds released from the germinating seeds and then a reaction of the seedlings of *Festuca arundinacea*, *Lolium multiflorum*, *Lolium perenne*, *Phleum pratense* and *Poa pratensis* to these allelopathic substances.

## Materials and methods

The studies were carried out using the density dependent phytotoxicity model which implies that the phytotoxic effects depend on density of plant-acceptors in an allelopathic environment (Weidenhamer, 1996). To avoid the soil and microbiological interactions, the bioassays were made on the Petri dishes in the laboratory conditions. The studies included six experimental series set up with complete randomized method in four replications. The experiments were conducted at daily 12h artificial light (average light intensity ca 3000 lux).

A special lamp fitting ensured appropriate and uniform plant lighting ( $U = ca\ 80\%$ ), room temperature ranged within  $22-25\ ^\circ C$ . To prepare the media for the main assay, the seeds of *F. arundinacea*, *L. multiflorum*, *L. perenne*, *Ph. pratense* and *P. pratensis* were spread on the plates on 3 layers of chromatographic filter paper (Whatman No 30001917), 15 and 30 units each (2 variants of seed density). Constant humidity of filter paper was maintained wetting it with distilled water. After seeds germination, the seedlings were developing for 14 and 28 days (2 variants of seedlings age) releasing colines, characteristic for each species-donor, into the medium (chromatographic paper) at a concentration dependent on a number of plants in a plate (15 and 30). The donors' seedlings were removed after 14 or 28 days and then 10 and 20 seeds (two densities) of *Ph. pratense* (acceptor) were put on the media obtained in this way. Control was constituted by the media where the species donors grew. After 10 days in all the objects there were evaluated root length, height and dry weight of acceptor's seedlings. The results were analyzed statistically in program SAS v. 9.1, using four-factor variance analysis, T-Tukey multiple test and T-Dunnnett test.

## Results and discussion

The allelocompounds released by the donor plants have exerted a significant impact on the early development of *Ph. pratense* (Figure 1).

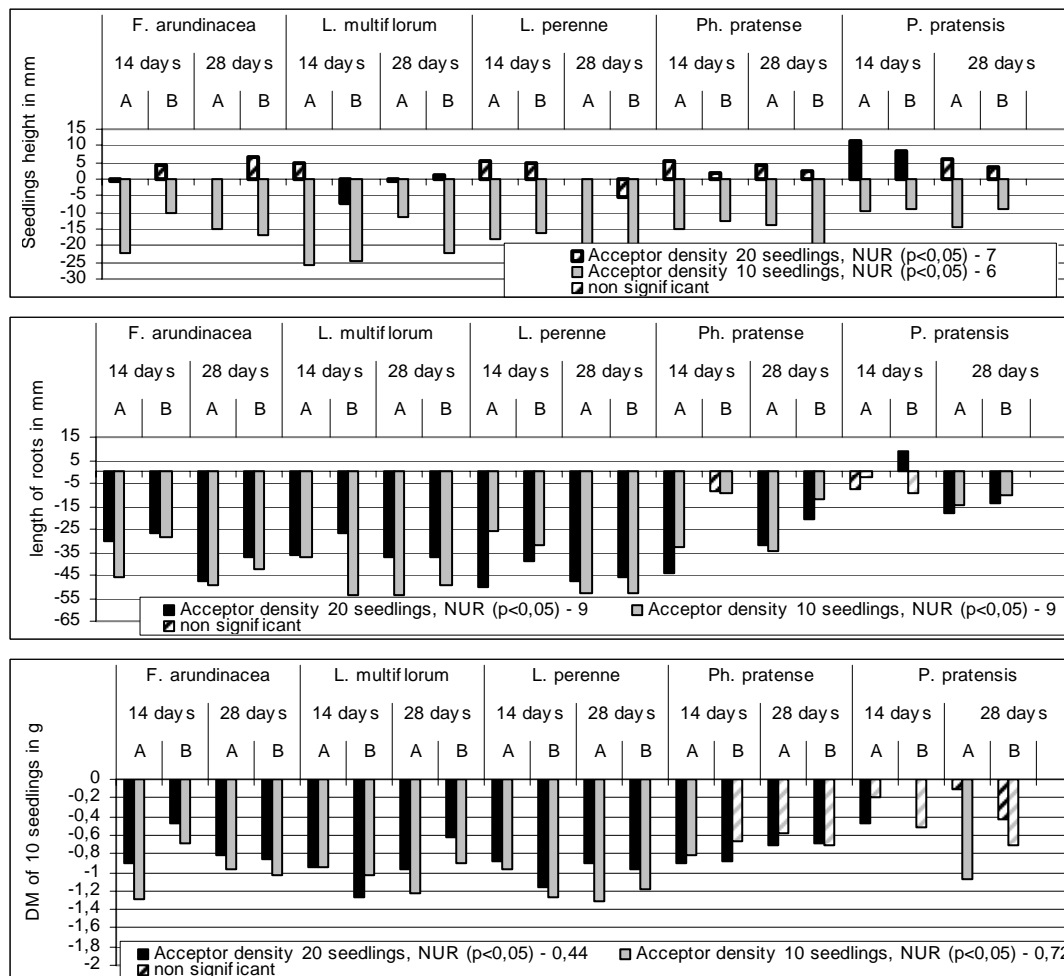

Figure 1. Differences in DM, root length and acceptor (*Ph. pratense*) seedlings height between the control and the objects with allelocompounds in relation to a donor species, age (14 and 28 days) and concentration of donor colines: A - 30 and B - 15 seedlings, respectively as well as acceptor seedlings density (10 and 20 seedlings)

A stimulatory or inhibitory influence of these substances depended not only on a donor species, concentration or age but on plant acceptors density as well. In all the objects with donor plants exudates, the acceptor seedlings produced significantly shorter roots and were of lower weight compared to the control. However, significantly shorter seedlings were recorded only in the objects of lower acceptor density. The differences in dry matter, root length and height of acceptor seedlings (between the control and the objects with allelocompounds in the media) ranged, subject to a species, age and donor concentration, from +0.4 up to -1.3 g; -2 to 53 mm and from +8 to -25 mm, respectively. The allelopathic substances released from all the donor species inhibited the initial development of *Ph. pratense* seedlings more intensively in the objects with lower density of this species

Dry matter, root length and height of *Ph. pratense* (acceptor) seedlings were the lowest in the objects with allelocompounds released into the medium by *L. perenne*, *L. multiflorum* and *F. arundinacea* irrespective of donor age, its allelocompounds concentration and plant acceptor density. Whereas, *P. pratensis* exudates inhibited the development of *Ph. pratense* seedlings to the smallest degree (Table 1).

Table 1. Seedling height (mm), root length (mm) and dry matter (g 10 seedlings<sup>-1</sup>) of *Phleum pratense* (acceptor) depending on their density (20 and 10 seeds), the age (14 and 28 days) and concentration of donors colines (30 and 15 seedlings, respectively)

Factors	Parameters		
	seedling height (mm)	root length (mm)	DM (g)
Donors	Mean for donors		
<i>Poa pratensis</i>	41a	45a	0,992a
<i>Phleum pratense</i>	38b	30b	0,894b
<i>Festuca arundinacea</i>	36bc	18c	0,632c
<i>Lolium multiflorum</i>	33d	14d	0,577d
<i>Lolium perenne</i>	35dc	12d	0,558d
LSD (p≤0,05)	2	2	0,020
Donor age	Mean for donor age		
14 days	37a	29a	0,736a
28 days	36a	18b	0,726b
LSD (p≤0,05)	1	1	0,0093
Concentration of donor colines respectively from:	Mean for concentration of donor colines		
30 seedlings	37a	21b	0,724a
15 seedlings	36b	27a	0,738b
LSD (p≤0,05)	1	1	0,0093
Acceptor density	Mean for acceptor density		
20 seedlings <i>Php</i>	38a	24a	0,813a
10 seedlings <i>Php</i>	36b	23a	0,648b
LSD (p≤0,05)	1	1	0,093

Means with the same letter are not significantly different

The allelopathic activity of these species was also shown in other studies. (Chung and Miller, 1995; Kraus *et al.*, 2002; Lipińska, 2005; Smith and Martin, 1994; Spyreas, 2001). Buta *et al.*, (1987) tested the following seed extracts in respect of the allelopathic activity: *F. arundinacea*, *L. perenne*, *L. multiflorum*, *P. annua* and *P. pratensis* and confirmed different inhibitory levels of the examined species. The most intensive inhibition was reported for *F. arundinacea* seeds, then *P. pratensis* and *L. perenne*. further for *P. annua* and *L. multiflorum*. Other studies imply that *P. pratensis* may even stimulate *Ph. pratense* seeds germination (Harkot and Jargiełło, 1980). The allelopathic activity of the allelocompounds released from the donor species depended on their age and a colines concentration. In the object where the donor plants grew longer (28 days) the acceptor plants generated significantly shorter roots and were of lower weight as against the objects where the donor plants grew shorter (14 days), yet the donor plant age did not differentiate in a significant way the height of the

acceptor seedlings. In the objects with higher concentration, corresponding with the impact of 30 seedlings' exudates, the seedling height, root length and dry matter of acceptor plants proved significantly lower as compared to those with a lower concentration (15 donor plant seedlings). The acceptor sensitivity to allelopathic influence of donor species depended on its density. In the objects of lower acceptor density (10 seedlings), its development inhibition proved stronger as against this in the objects with higher density (20 seedlings). It is thought that weaker development of a species at the conditions of lower density of plants is contradictory to the plant competition effect for environment resources, therefore may suggest some activity of a chemical nature (Weidenhamer, 1996). Similarly, the studies of Bullock *et al.*, (1994) and Wardle *et al.*, (1996) on varied density of acceptor plants show that, beside the competition for resources, there appear some other interference mechanisms between the investigated grass species.

## Conclusions

Different development of *Ph. pratense* (acceptor) seedlings in the objects with allelocompounds released into the medium by the seedlings of *F. arundinacea*, *L. multiflorum*, *L. perenne*, *Ph. pratense* and *P. pratensis* as against the control confirms their influence on the conditions of acceptor plant development. Stronger inhibition of acceptor seedlings development in the objects of their lower density may indicate some influence of an allelopathic nature. Yet, it is not obvious that this activity in the field conditions will occur at a sufficient concentration and be of agronomical importance. Nevertheless, it allows understanding better the plant interactions in the environment. The disorders reported in the initial stage of plant development may affect their nutrient management, photosynthesis, water uptake and transportation. The species attenuated in the early development stages by the allelocompounds may be forced out from the plant associations by the species less susceptible to these substances.

## References

- Bertin C., Paul R.N., Duke, S.O. and Weston, L.A. (2003) Laboratory assessment of the allelopathic effects of fine leaf fescues. *Journal of Chemical Ecology* 29: 1919–1937.
- Bullock J. M., Mortimer A. M., Begon M. (1994) The effect of clipping in interclonal competition in the grass *Holcus lanatus* – a response surface analysis. *Journal of Ecology*, 82, 259-270.
- Buta J.G., Spaulding D.W. (1987) Growth inhibiting compounds in tall fescue involved in allelopathy of turfgrasses – abscisic acid and phenolics. In: Plant Growth Regulator Society of America, *Proceedings of the Plant Growth Regulator Society of America*, Lincoln, Nebraska, USA, 61.
- Chung I.M., Miller D.A. (1995) Allelopathic influence of nine grass extracts on germination and seedling growth of alfalfa. *Agronomy Journal*. 87: 767–772.
- Emeterio L.S., Arroyo A., Canals R.M. (2003) Allelopathic potential of *Lolium rigidum* Gaud. on the early growth of three associated pasture species. *Grass and Forage Science* 59: 107–112.
- Harkot W., Jargiełło J. (1980) Laboratory tests on germination of 3 cultivars of *Phleum pratense* L. in mixture with grasses and *Trifolium pratense* L. *Biuletyn IHAR* 140: 67-72. (In Polish, with English abstract).
- Lipińska H. (2005). Allelopathic effects of grasses and biodiversity of plant communities. *Grassland Science in Europe* 10: 380–383.
- Lipińska H., Harkot W. (2005) Allelopathic effects of water leachates of *Poa pratensis* leaves. *Allelopathy Journal* 16: 251–260.
- Rice E.L. 1984. Allelopathy. Academic Press, New York: ss. 422.
- Smith A. E., Martin L. D. (1994) Allelopathic characteristics of three cool-season grass species in the forage ecosystem. *Agronomy Journal*, 86, 243-246.
- Spyreas G., Gibson D.J., Middleton B.A. (2001) Effects of endophyte infection in tall fescue (*Festuca arundinacea*, *Poaceae*) on community diversity. *International Journal of Plant Science* 162, 1237–1245.
- Weidenhamer J. D., (1996) Distinguishing Resource Competition and Chemical Interference: Overcoming the Methodological Impasse. *Agronomy Journal* 88, 866-875.

# Shading effects of trees on flora composition and plant diversity

Kyriazopoulos A.

*Democritus University of Thrace, Department of Forestry and Management of the Environment and Natural Resources, 193 Padazidou str., 682 00 Orestiada, Greece*

## Abstract

The objective of this study was to evaluate the shading effects of trees on flora composition of the understorey vegetation and on floristic diversity. The study was conducted in Northern Greece in beech (*Fagus sylvatica* L.) forested areas where shading levels were 95% and 75%, measured by a Licor quantum sensor. The experimental area was not grazed. In June 2005, in every forested area of different shading level, 3 transects were established. As control treatment, 3 transects were established in an adjacent open grassland (shading level 0%). Flora composition was measured and the biotic and ecological form of the understorey vegetation was defined. Floristic diversity indexes were also determined. The understorey flora composition was significantly altered. The open grassland was dominated by the perennial grasses *Dactylis glomerata* and *Poa pratensis*, the 75% shading level forested area was dominated by the species *Bromus benekenii* and *Rubus sanctus*, while the 95% shading level forested area was dominated by the species *Rubus sanctus* and *Pteridium aquilinum*. Floristic diversity was significantly affected by shading as well.

Keywords: agroforestry, light intensity, floristic diversity, ecological form

## Introduction

The knowledge of the interactions between herbaceous and woody vegetation in agroforestry systems is vital to the alteration of this relation by management practices so as to provide the most efficient utilization of the natural resources (Rao *et al.*, 1998). The range value of silvopastoral systems depends mainly on the canopy density, which affects light availability to the understorey vegetation and consequently species composition and forage production (Papanastasis, 1996). Shading effect on species composition is related to the individual species. Cool season grasses are benefited by light to moderate shading, while warm season species and most of the legumes are suppressed (Pieper, 1990). The biotic and the ecologic form of the herbaceous vegetation represent in high degree the climatic conditions of a region. Trees might critically modify the microclimate and as a consequence can alter the life form and the ecological spectra.

It is well documented that the stability of the ecosystems is closely related to species diversity. Biodiversity is enhanced in agroforestry systems by the gradients of environments that are created within (vegetation structure, shading, moisture) according to Mosquera-Losada *et al.* (2005). On the other hand, shading affects directly the photosynthetic ability of the understorey vegetation (Bergez *et al.*, 1997). Consequently only the shade tolerant species can grow up under heavy shading. Vrahnakis *et al.* (2005) reported that floristic diversity was significantly lower in the understory of a dense fir forest compared to an adjacent open rangeland.

The purpose of this study was to evaluate the shading effects of trees on flora composition of the understorey vegetation and on floristic diversity.

## Materials and methods

The study was conducted in the area of Laggadia, Pella prefecture, northern Greece close to the borders of FYROM (40°45'N, 22°58'E at 600 m altitude). The climate of the area is classified as subhumid Mediterranean, with a mean air temperature of 13.9°C and an annual rainfall of 453 mm. The soil of the study area is classified as *chromic luvisol* according to the FAO soil system classification (Kyriazopoulos, 2001). The area is situated at the lower limits where *Fagus sylvatica* L. occupies in the alliance of *Fagion moesiaca*, association *Fagetum submontanum* (Athanasiadis, 1986). The experimental area was not grazed.

The shading levels, as measured by a Licor quantum sensor, in two beech (*Fagus sylvatica* L.) forested areas were 95% and 75%. During June 2005 three transects were established in every forested area with different shading level. For comparative purposes three transects were established in an adjacent open grassland (shading level 0%). Floristic information was obtained by the use of the line-intercept method (Bonham, 1989). Contacts were obtained every 20 cm (100 contacts per transect) and taxa intercepted were recorded according to their name given by Flora Hellenica, vol. 1, 2 (Strid and Tan 1997-2002), Mountain Flora of Greece (Strid 1986, Strid and Tan 1991) and Flora Europaea (Tutin *et al.* 1968-1980, 1993). Bare ground records were excluded from the analysis.

Species composition was measured and the biotic and ecological form of the understorey vegetation was defined. The formation of the life form and the ecological spectra were produced for every shading treatment, using Raunkiaer's (floristic approach) method (1910). Floristic diversity was determined by the species richness (N) and the Shannon-Weiner index of  $\alpha$ -diversity ( $H'$ ). The formulae of the indices are given below:

$$H' = -\sum_{i=1}^S p_i \ln p_i \quad (1)$$

$$N \quad (2)$$

where, S is the maximum recorded number of taxa,  $p_i$  is the proportional abundance of the  $i$ -th taxa, N is the number of taxa.

The data were subjected to analysis of variance (one-way ANOVA) using the MSTAT program while the Duncan test was used for means comparison (Snedecor and Cochran, 1967).

## Results and discussion

The understorey flora composition was significantly altered (Table 1). A total of 38 taxa were identified. Taxa richness attained its maximum value in grassland (30 taxa recorded), followed by the forested area with shading level of 75% (24 taxa), and the forested area with shading level of 95% (16 taxa). The open grassland was dominated by the perennial grasses *Dactylis glomerata* and *Poa pratensis*, the 75% shading level forested area was dominated by the species *Bromus benekenii* and *Rubus sanctus*, while the 95% shading level forested area was dominated by the species *Rubus sanctus* and *Pteridium aquilinum*.

According to the ecological spectra (Figure 1) phanerophytes increased as shading increased, while therophytes decreased. The growth of the therophytes is not favoured by the conditions in a forested area. The life form spectra shows that trees and shrubs increased, whereas the annual herbaceous species decreased (Figure 2). These findings suggest that the forested areas are more stable than the open grassland as less annual herbaceous species exist under the shady forested areas.

Table 1. Species composition in the three shading levels.

Taxa	Shading level (%)			Taxa	Shading level (%)		
	0	75	95		0	75	95
<i>Achillea clypeata</i>	0.0	0.0	0.3	<i>Holcus mollis</i>	0.0	0.0	0.3
<i>Arctium minus</i>	0.7	1.0	1.0	<i>Lamium purpureum</i>	1.7	0.3	0.0
<i>Aristolochia rotunda</i>	0.0	4.0	5.7	<i>Lathyrus pratense</i>	2.3	1.3	0.7
<i>Astragalus glycyphyllos</i>	0.0	2.3	0.0	<i>Lolium perenne</i>	4.0	0.3	0.7
<i>Avena sterilis</i>	0.3	0.0	0.0	<i>Luzula luzulina</i>	1.3	5.3	6.0
<i>Briza minima</i>	1.3	0.0	0.0	<i>Medicago falcata</i>	1.0	0.0	0.0
<i>Bromus benekenii</i>	8.7	27.7	4.0	<i>Nepeta nuda</i>	0.7	4.0	0.0
<i>Bromus sterilis</i>	0.3	0.0	0.0	<i>Phleum pratense</i>	2.7	0.0	0.0
<i>Cirsium sp.</i>	2.3	0.7	0.0	<i>Piptatherum miliaceum</i>	2.0	0.0	0.0
<i>Crataegus monogyna</i>	0.0	0.4	2.3	<i>Poa pratensis</i>	12.7	5.3	0.0
<i>Cruciata laevipes</i>	7.0	0.7	0.0	<i>Pteridium aquilinum</i>	3.0	14.3	28.3
<i>Dactylis glomerata</i>	13.7	0.7	0.0	<i>Quercus petraea</i>	0.0	0.0	0.3
<i>Dorycnium pentaphyllum</i>	2.3	0.0	0.0	<i>Rosa sp.</i>	0.0	2.0	0.0
<i>Eryngium campestre</i>	6.3	1.0	0.0	<i>Rubus sanctus</i>	1.0	19.7	28.7
<i>Fragaria vesca</i>	3.0	0.0	0.0	<i>Taraxacum officinalis</i>	0.7	1.0	4.3
<i>Galium aparine</i>	3.0	0.0	0.0	<i>Tordylium apulum</i>	0.0	2.7	10.7
<i>Galium spurium</i>	9.0	3.0	4.0	<i>Trifolium repens</i>	2.0	0.0	0.0
<i>Geranium columbinum</i>	1.7	0.3	0.0	<i>Vicia cracca</i>	4.0	0.3	0.0
<i>Hieracium bauhini</i>	0.3	0.0	0.0	<i>Vicia grandiflora</i>	1.0	1.7	2.7

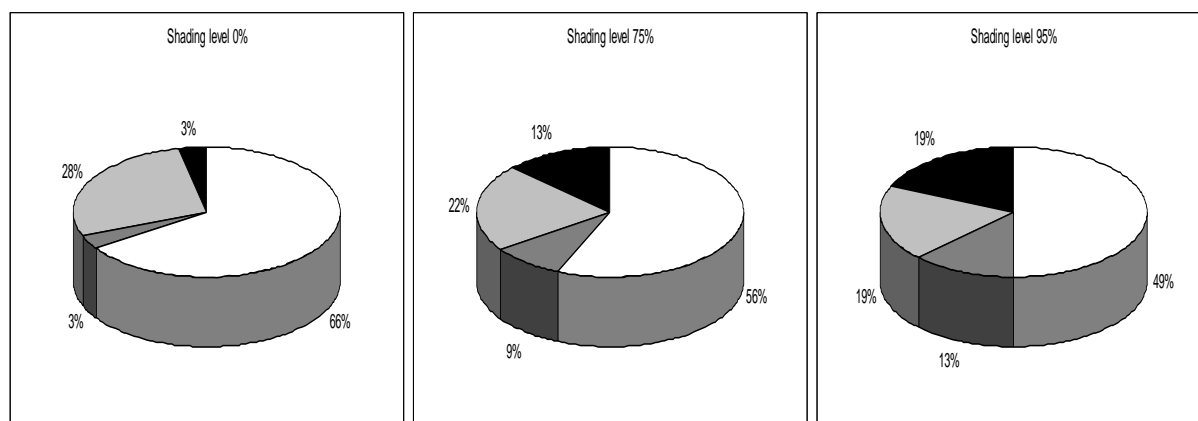

Figure 1. Life form spectra for the three shading levels (○=Hemicryptophytes, ●=Geophytes, ◐=Therophytes, ◑=Phanerophytes)

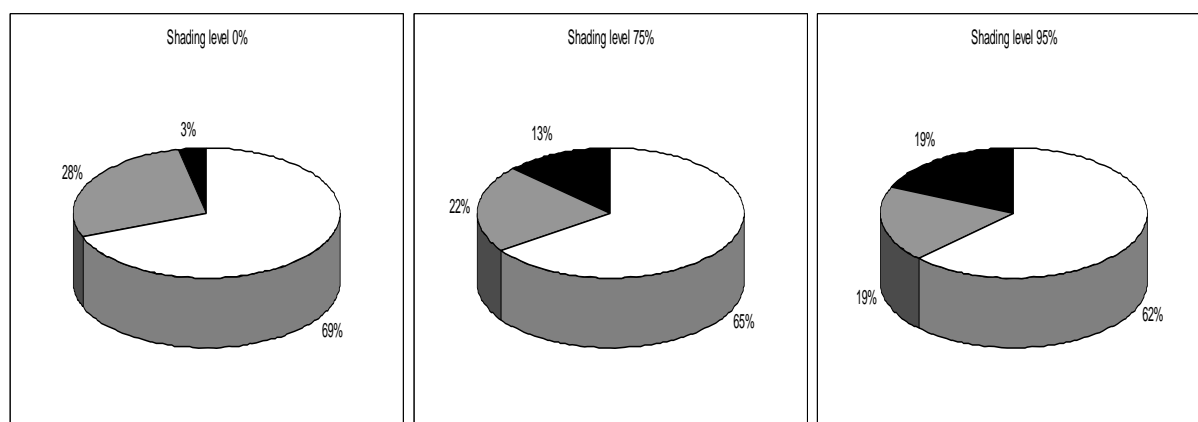

Figure 2. Ecological spectra for the three shading levels (○=perennials, ●= annuals, ◑=trees and shrubs)

Species richness, as described by the number of species, and Shannon-Weiner index were significantly higher in the open grassland compared to the 95% shading level forested area. No significant differences were found for these floristic diversity indexes in the open grassland compared to the 75% shading level forested area and between the two forested areas (Table 2).

Table 2. Floristic diversity indexes for the three shading levels

Diversity index	Shading level					
	0%		75%		95%	
Species Richness (N)	19.00	a*	15.33	ab	11.33	b
Shannon-Weiner index (H)	2.57	a	2.15	ab	1.93	b

\* Means in the same line with the same letter are not statistically significant at the 0.05 level.

The results indicate that floristic diversity decreased as light intensity decreased, but only when this decrease was intense. Kyriazopoulos *et al.* (2006) have found increased floristic diversity under light and moderate shading compared to open areas with no shading. These suggests that floristic diversity increases as shading increases, but after a shading limit it starts to decrease.

## Conclusions

Shading significantly altered the understorey flora composition and reduced the annual herbaceous species. Heavy shading (shading level 95%) decreased the floristic diversity.

## References

- Athanasiadis N. (1986) Forest phytosociology. Giahoudi – Giapouli Press. Thessaloniki, Greece. pp. 119. (In Creek, English summary).
- Bergez J.E., A.J.I. Dalziel, C.Duller, W.R. Eason, G. Hoppe and R.H. Lavender. 1997. Light modification in a developing silvopastoral system in the UK: a quantitative analysis. *Agroforestry Systems*, 37, 227-240.
- Bonham C.D. 1989. Measurements for Terrestrial Vegetation. Wiley Interscience, New York, USA.
- Kyriazopoulos A. P. (2001) Effects of shading and livestock grazing on the herbaceous vegetation to agrosilvopastoral systems. Dissertation. Thessaloniki. pp. 147. (In Creek, English summary).
- Kyriazopoulos A., A.S. Nastis and Z. Koukoura. 2006. Effects of shading on species richness, above-ground biomass production and litter in an agroforestry system. *Grassland Science in Europe*, 11, 460-462.
- Mosquera-Losada R., A. Rigueiro-Rodriguez, M. Rois-Dias, A. Schuck and J. Van Brusselen, 2005. Assessing Biodiversity on silvopastoral systems across Europe. *Grassland Science in Europe*, 10, 44-51.
- Papanastasis V. 1996. Silvopastoral systems and range management in the Mediterranean region, p. 143-156. In: Etienne M. (ed.), Western European Silvopastoral Systems. INRA, France.
- Pieper R.D. 1990. Overstory – understory relation in pinyon – juniper woodlands in New Mexico. *Journal of Range Management*, 43, 413-415.
- Rao, M.R., P.K.R. Nair and C.K. Ong. 1998. Biophysical interactions in tropical agroforestry systems. *Agroforestry Systems*, 38, 3-50.
- Raunkiaer, C. 1910. Statistik der Lebensformen als Grundlage für die biologische Pflanzengeographie. Beihefte zum Bot. Central bl. XXVII (1): 171-206
- Snedecor G. W. and Cochran, W. G. (1967) Statistical Methods, 6th edition. The Iowa State University Press. Ames, Iowa, USA.
- Stri, A. (1986) Mountain flora of Greece, 1. Cambridge, pp. 822.
- Strid A. and K. Tan. (1991) Mountain flora of Greece, 2. Edinburgh, pp. 974
- Strid A. and K. Tan (eds.) (1997) 2002. Flora Hellenica vol. 1-2. Patra.
- Tutin T.G., N.A. Burges, A.O. Chater, J.R. Edmonson, V.H. Heywood, D.M. Moore, D.H. Valentine, S.M. Walters and D.A. Webb (eds) (1993) Flora Europea I. 2nd edition. Cambridge.
- Tutin T.G., V.H. Heywood N.A. Burges, D.M. Moore, D.H. Valentine, S.M. Walters and D.A. Webb (eds.). 1968-1980. Flora Europaea II - V. Cambridge.
- Vrachnakis M.S., A.P. Kyriazopoulos G. Fotiadis A. Sidiropoulou and A. Dionisopoulou (2005) Changes in components of floristic diversity in three adjacent rangeland types. *Grassland Science in Europe*, 10, 144-148.



# Influence of insolation and renovation method on the grass areas in the 3-5<sup>th</sup> year after renovation at the old park

Gutkowska A.

*Institute of Land Reclamation and Grassland Farming at Falenty, Al. Hrabaska 3, 05-090 Raszyn, Poland*

## Abstract

The effect of insolation and renovation method on the grass areas (botanical composition, ground cover area by plants, plant masses) in the 3-5<sup>th</sup> year after renovation in the old park in Palace-Park Complex in Falenty was the subject of the paper. Three methods of renovation (oversowing, full cultivation and intensive cutting) were compared. The study on two areas with different light conditions was carried out during the period 2004-2006. Light conditions didn't decide about species number, but grasses and dicotyledonous plants share depended upon insolation. The plants cover and plant mass were higher on area with more intensive insolation.

Keywords: cover, botanical composition, biomass, insolation, country parks

## Introduction

The old parks make up inseparable element beside palace buildings in Palace-Park Complexes. These parks possess historical value. The old trees with status of nature monuments very often grow there. Many precious country parks in Poland have been undergone destruction. Protection, renovation and appropriate cultivation of them is very important and needed beside conservation of antique buildings. Low plants decide about park character. Well-kept herbage emphasise beauty of another plants and historical buildings. Nevertheless obtaining a good ground cover by plants and appropriate botanical composition is very difficult in park because of diverse light conditions (Starck *et al.*, 1995; Mahallati, 1998; Niczyporuk, 2000). Estimation of renovation methods effectiveness in the 3-5<sup>th</sup> year after renovation and influence of insolation on low park plants in Falenty Park was the aim of this paper.

## Material and methods

Two grass areas (area I and area II) with different light conditions, localised in the 17<sup>th</sup> century Palace-Park Complex in Falenty near Warsaw in Poland were the subject of the study. The park composition scheme was changed but none planned renovation treatments have pursued on Falenty Park for several dozen years. Area I located in a place with bigger insolation (mean 506 W·m<sup>-2</sup>) and characteristic tree stand – *Tilia cordata*. Area II was characterised by less intensive sunshine (mean 278 W·m<sup>-2</sup>) and trees – *Quercus robur*. The light conditions, expressed insolation, were defined on the base of total radiation, using systematically in all vegetation period a thermostat in the sunny days and an albedometer in the cloudy one. The renovation was carried out in spring 2002. Three renovation methods were compared: 5 cuts utilisation, oversowing with verticulator and full cultivation with rototiller. Two grass mixtures were used: foreign mixture produced by Barenbrug Company (M1) and Polish mixture (M2). M1 contained *Lolium perenne* (Figaro 16%, Stadion 14%), *Poa pratensis* (Nimbus 15%), *Festuca rubra* (Bargena 30%, Barskol 10%, Bernica 15%), and

M2 – *Lolium perenne* (Nadmorski 50%), *Poa pratensis* (Balin 10%), *Festuca rubra* (Areta 10%, Leo 20%), *Festuca ovina* (Spartan 10%). The treatments had 4 replications and each plot size was 4 m<sup>2</sup>.

Plants on studied grass areas were estimated before the renovation (2001) and few years later – in the 3-5<sup>th</sup> year after renovation (2004-2006). Plants cover of area estimated systematically by Pronczuk scale (Prończuk 1993) before the renovation and in period 2004-2006. The floristic composition was signified by botanical analyses before renovation and in 2004. Plant mass (green material and dry matter DM) was measured in 2005 and 2006.

The data were processed statistically using analysis of variance. Differences among treatments were tested using LSD test.

## Results and discussion

The state of park herbage before renovation didn't allow performing a representative and landscape shaping role in view of low leaves cover and unsuitable botanical composition (small low grasses and perennial plant share in sward). It's changed markedly after 3-5 years of the trial.

The herbage studied areas in the park before renovation characterised by a species richness - 45 species were distinguished (15 - monocotyledonous and 30 dicotyledonous). Although species number was similar on both areas, plant group share was different. The grasses dominated (over 50%) on area with bigger insolation and dicotyledonous plants (over 70%) - on less insolated area. Low grasses share, recommended on park sward such as *Poa pratensis*, *Lolium perenne* and *Festuca rubra*, was very low, and it averaged 9% on area II and 19% on area I. After few years of renovation the species number in every renovation variants increased about a few species, but general all species number, distinguished on studied area, didn't increased. On both areas and in every renovation variant the grasses share increased and dicotyledonous plants share decreased. The ruderal and scrubby plant, which occurred frequently in park sward in 2001, has started to subside in next years.

High grasses better developed on area with more intensive solar radiation and dicotyledonous plants –on area with less insolation. The big of low grasses share in park sward (mean 83%), mainly *Lolium perenne*, and the smallest number of plant species were affirmed on places renovated by full cultivation. Oversewing didn't decrease species number such as full cultivation and low grasses share averaged 70-80% on these places. The low grasses share on places renovated by cutting averaged 27-37 %.

The ground cover by leaves in the 3<sup>rd</sup>, 4<sup>th</sup> and 5<sup>th</sup> year after renovation (on average over 60%) was better than before renovation (30-40%). The cover was depended on area localisation (different light conditions) and renovation methods (Figure 1). Higher cover on more insolated area than on area with less isolation was observed. On area I the most plants cover in variants with mixture M1 (oversowing and full cultivation) and the least – in variant of oversewing mixture M2 was obtained. On area II the most cover by plants occurred in places renovated by oversewing mixture M1 and the least – in full cultivation variant with mixture M2.

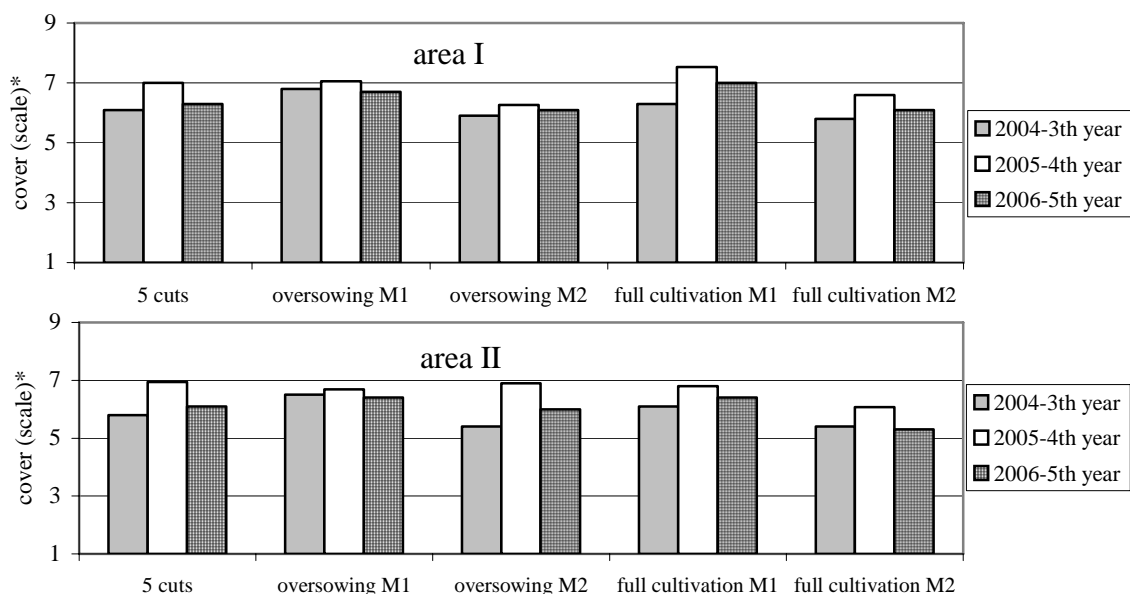

Figure 1. Leaves ground cover (in 9 scale) in depended on the area with different light conditions and renovation methods

\*Pronczuk scale (Pronczuk 1993), where 1 means 0% leaves cover (lack of plants), 3-20 %, 5-60 %, 7-80 % and 9-100 % (perfect cover)

Plant mass in Falenty park wasn't high (Table 1) and a role of the plants in the park isn't giving a big crop. Location of examined grass areas in different light conditions had the influence on rate of plant mass. The bigger plant mass was reaped from the area with less insolation. Substantial differences were affirmed in variants: 5 cuts in 2006, full cultivated with both mixtures (M1 and M2) in 2005. The biggest of plant masses reaped in renovation variants: 5 cuts (with old sward) and full cultivation with M1 on both examined areas and the lowest one measured in full cultivation variant with M2 on area I and in places renovated by oversowing with polish mixture on area II. Generally the plant masses were higher in 2005 than in 2006, beside of oversowing with foreign mixture M1 on both areas and oversowing with polish mixture in area less insolated, because of long periods without atmospheric precipitation in summer 2006.

Table 1. Effect of renovation methods and light conditions on plant mass ( $\text{g m}^{-2}$ ) in the 4<sup>th</sup> and 5<sup>th</sup> year after renovation

renovation method	year	green material ( $\text{g m}^{-2}$ )			DM ( $\text{g m}^{-2}$ )		
		area I	area II	<i>average</i>	area I	area II	<i>average</i>
5 cuts	2005	1399	1744	1572	261	288	275
	2006	665	1205	935	133	286	210
	<i>average</i>	1032	1475	1253	197	287	242
oversowing M1	2005	800	848	824	142	134	138
	2006	838	1218	1028	165	254	210
	<i>average</i>	819	1033	926	154	194	174
oversowing M2	2005	1051	869	960	189	126	158
	2006	839	1128	984	179	235	207
	<i>average</i>	945	999	972	184	181	182
full cultivation with M1	2005	1067	1879	1473	218	291	255
	2006	982	1122	1052	224	235	230
	<i>average</i>	1025	1501	1263	221	263	242
full cultivation with M2	2005	857	1474	1166	152	232	192
	2006	674	1105	890	132	241	187
	<i>average</i>	766	1290	1028	142	237	189
				LSD <sub>0,05</sub> for area 450; LSD <sub>0,05</sub> for year 450, LSD <sub>0,05</sub> for renovation method 1001	LSD <sub>0,05</sub> for area 47; LSD <sub>0,05</sub> for year 47, LSD <sub>0,05</sub> for renovation method 105		

## Conclusion

Light conditions and renovation methods shaped state of park grass areas. Every renovation methods have been improved herbage condition (botanical composition, cover). The plants cover was the better on the area with bigger insolation. Renovation methods had minor influence on ground cover. Floristic changes more depended on renovation methods than light conditions. High grasses better developed on area with more intensive solar radiation and more of dicotyledonous plants occurred on area with less insolation. The big low grasses share in park sward (mean 83%), mainly *Lolium perenne*, and the smallest number of plant species were affirmed on places renovated by full cultivation. Oversowing weren't decreased species number such as full cultivation and low grasses share averaged 70-80% on these places. The low grasses share on places renovated by cutting averaged 27-37%. Location of examined grass areas in different light conditions had the influence on rate of plant mass. The bigger plant mass was reaped from the area with less insolation. Generally the plant masses were higher in 2005 than in 2006 because of long periods without atmospheric precipitation in summer 2006.

## References

- Mahallati M.N. (1998) Modelling Interaction in Grass-Clover Mixtures. Wageningen Agricultural University, 165 pp.
- Niczyporuk A (2000) Ekosystemy trawiaste w kształtowaniu i ochronie środowiska. Wyd. Politechniki Białostockiej, Białystok, 137 pp.
- Prończuk S. (1993) System ocen traw gazownowych. Biul. IHAR 186, 127-131.
- Starc Z., Chołuj D., Niemyjska B. (1995) Fizjologiczne reakcje roślin na niekorzystne czynniki środowiska. Wyd. SGGW Warszawa, 167 pp.

## Session 3

# Socio-economical impact



# Impact of the CAP-reform of 2003 on the use of pastoral land in Europe.

Roeder N.<sup>1</sup>, Hennessy T.<sup>2</sup> and Stilmant D.<sup>3</sup>

<sup>1)</sup> TUM (Technische Universität München) – Environmental Economics and Agricultural Policy, Alte Akademie 14, D-85350 Freising, Germany

<sup>2)</sup> Teagasc - Rural Economy Research Centre – Athenry, Galway, Ireland

<sup>3)</sup> CRA-W - Walloon Agricultural Research Centre, Rue du Serpont 100, B-6800 Libramont, Belgium

## A) Introduction

Farming systems based on products of roughage feeders are a vital part of EU agricultural production and account for roughly a quarter of the total production value of EU agriculture (Szabó and Milella, 2006). Up to the reform of the Common Agricultural Policy (CAP) in 2003, the EU promoted farming with roughage feeders via a wide variety of measures (examples: special male premium, suckler cow premium, ewe premium). All these support mechanisms were similar in that payments were proportional to the number of stocked animals. The 2003 reform implemented a complete change in the support system, since the premiums were decoupled from the number of stocked animals and instead recoupled to the eligible land area farmed. In particular, permanent pastures became eligible for direct payments. Hence, the definition of permanent pasture became important.

Therefore we structure the paper as follows; first some definitions of key terms and background information are presented. In the second section, we analyse the impact of the CAP up to 2003 on the use of pastoral land. Afterwards, we depict the main mechanisms of the 2003 reform relevant for the use of pastoral land and how the members implemented the reform. This is followed by a description of the impacts of the reform on agricultural commodity markets. The paper finishes with the presentation of some national case studies and draws conclusions. Throughout the text offices and legal documents are cited with their official abbreviation in the text. The full name of the source is given in the reference.

## B) Definition and background information

Under the term roughage feeder all domesticated cattle, buffalo, goats, sheep, domestic deer and equids are grouped. Despite the fact that for instance EUROSTAT publications use the term ‘pastoral animal’ instead of ‘roughage feeder’, it is far from the truth to assume that all these animals are actually on pasture or even that these animals depend on grassland be that cut or grazed. Especially, in central and north-western Europe, most of the dairy cattle are kept indoors all year round. Furthermore, silage maize accounts for roughly one fifth of the main forage area of Germany, France, Denmark and the BeNeLux (EUROSTAT, 2005b). Even if animals graze on land which is not included in any form of crop rotation, one cannot conclude that these animals necessarily use ‘permanent pastures’. According to Commission Regulation (EC) No 796/2004, permanent pasture is ‘land used to grow *grasses* or other *herbaceous* forage naturally (self-seeded) or through cultivation (sown)’, this would exclude for instance the moorlands of Western Europe where heather (*Calluna vulgaris*), a dwarf shrub, is the dominant plant species. Furthermore, even grazed areas where vegetation is dominated by grasses can be excluded from the statistics, if they are primarily used for other non-agricultural purposes. All this makes the official statistical records on the extent of the development of grassland and pastorally used land problematic. For the purpose of this paper we will define pastoral land as being land devoted to the nutrition of roughage feeders and not

included in a crop rotation. Arable land is only included if it is grazed, which is common on the Iberian Peninsula.

In 2003, the stock of roughage feeder in the EU-25 accounted for slightly more than 70 million livestock units (LU) (EUROSTAT, 2005a). By far the most important single group are dairy cattle which account for 24 of the 62 million LU in cattle. Dairy farming is concentrated on the coast of continental Europe from the Normandy region to Denmark (Figure 1). The areas in and around the Alps constitute a second hotspot. While dairy cattle are the dominant type of roughage feeders in Poland, the Baltics and Northern Scandinavia, their importance in terms of the utilised area is relatively small (EUROSTAT, 2005c). Meat production via beef cattle and sheep is dominant in the North and West of the British Isles, Central and Southern France and the Mediterranean.

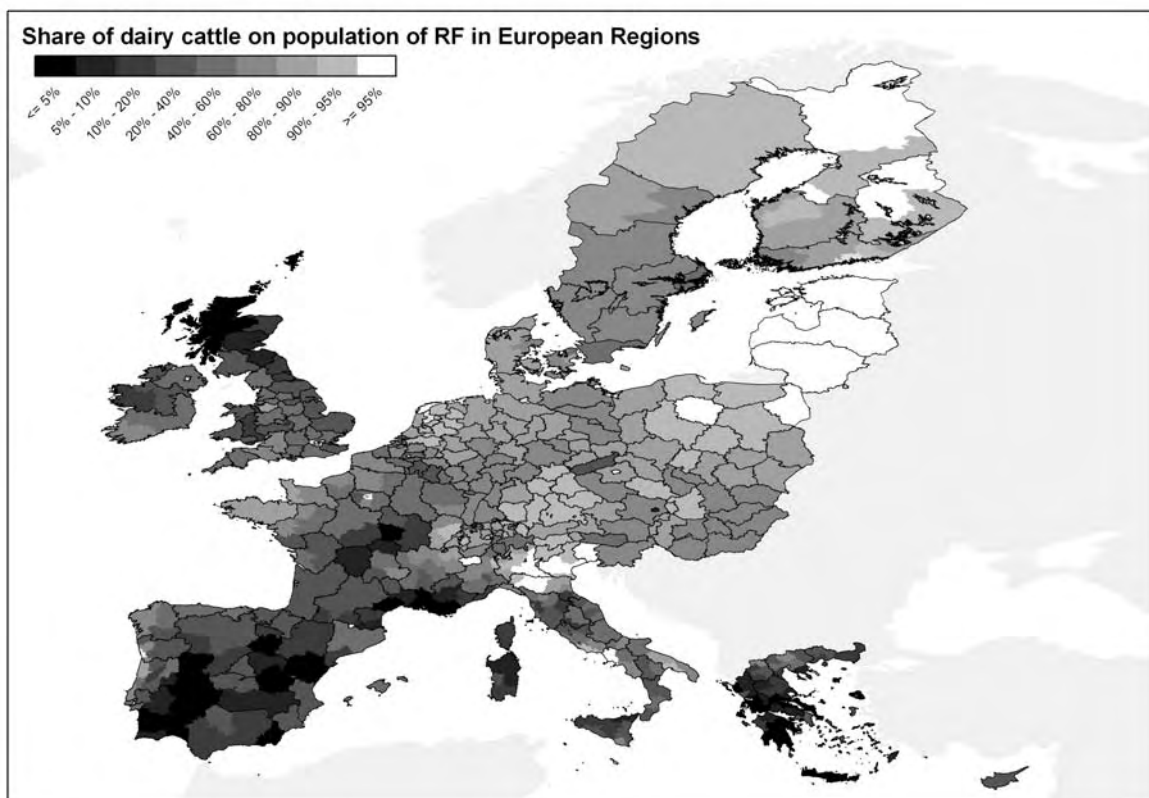

Figure 1: Relative share of dairy cattle and their replacement on the population of roughage feeders throughout Europe in 2003 (in LU)

Sources: Cyprus and Poland (EUROSTAT, 2005a); rest of the EU (EUROSTAT, 2005c); Switzerland (BFS, 2005)

While arable land, mostly silage maize, plays an important part in the nutrition of dairy cattle and fattening bulls in Northern and Central Europe, it is integrated completely differently into the livestock sector in the Mediterranean (Figure 2). Here predominantly sheep graze nearly exclusively on cereal stubbles for a couple of months of the year. Only in Central and North-Eastern Europe, permanent grassland is used nearly exclusively by dairy cattle whereas in the other regions meat production also has some importance (e.g. British Isles and France) or is predominant (Spain). Non-agricultural land is mostly utilized in extensive meat producing systems (suckler cows and sheep) with the only exception being the alpine system most of this land is grazed by heifers needed for the replacement of dairy cattle. The higher importance of non-agricultural land in the Atlantic and Mediterranean biogeographical zone can be attributed to the fact that under semi-natural management conditions the respective



climatic conditions favour woody vegetation to the expense of grasses. This is contrasting with more temperate or continental conditions.

		Farming system			
		Dairy cattle	Dairy cattle and suckler cows <sup>1)</sup>	Fattening Bulls	Suckler cows only
Main forage source on regional level	Arable land and non agricultural land				ES, GR
	Arable land	SE, FI, DK, HU Northern IT		locally in DE, IT, NL	
	Arable land and permanent pasture	DE, SE, FI, DK, NL, F, BE, NMS10			PT, ES
	Permanent pasture <sup>2)</sup>	AT, DE, PL, Baltics	FR, IE, UK, NMS 10 without Baltics, PL and HU	FR	Southern IT; ES, BE (Wallonia), HU
	Permanent pasture and non agricultural land		AT		IE, UK

Figure 2. Typology of farming systems with roughage feeders in the EU members based on the dominant forage source.

Source: Poland (EUROSTAT, 2005a); rest of the EU (EUROSTAT, 2005c)

- 1) suckler cows includes all livestock kept at low intensity for meat production like sheep, goats, oxen as well as milking ewes and milking goats
- 2) According to Commission Regulation (EC) No 796/2004

### C) Brief history of the CAP and its impact on the use of pastoral land

Starting with the Treaty of Rome in 1957, European policy influenced the agricultural sectors, and consequently the extent and intensity of farming was co-determined by political decisions. In the first years of the CAP, its main goals were among others, the increase of agricultural production and the promotion of technical progress while ensuring a fair standard of living for the agricultural communities. In order to achieve these goals, markets were protected and high prices granted. While in the late 1950s, the European rate of self-sufficiency for agricultural product was below 90% (Clerc, 1964), the measures of the CAP promoted the intensification of agricultural production and led to a strong increase in production and by the mid 1970s an oversupply existed for most agricultural commodities, making export subsidies necessary in order to maintain the high domestic price levels. The increasing total production can be mainly attributed to higher yields per animal while the stocks remained at more or less constant levels (Cropper and Del Pozo-Ramoz, 2006). In the mid 1970s, the first schemes promoting marginal rural areas started (Council Directive EEC 268/1975). These schemes stabilized especially the number of sheep and promoted suckler cow farming with the exemption of Ireland, the UK, Italy and Denmark (EUROSTAT, 2005a). By the 1980s the costs of the CAP sky-rocketed since the price support system induced high levels of production. In order to stabilize the cost of the CAP, prices for agricultural products were cut back in several steps and the milk quota system was introduced in 1984 to limit milk production. But the technological progress in dairy farming did not stop, mainly because the annual milk yields per animal increased continuously. Therefore, each year, fewer animals are needed to produce the same quantity of milk, consequently the stock of dairy cattle declined constantly by roughly 2% p.a. ever since quotas were established (EUROSTAT 2005a). While the number of beef cattle<sup>1</sup> peaked in the mid-eighties and early

<sup>1</sup> in the meaning of all types of cattle but dairy cows

nineties in the EU and declined since then by 1% annually, the number of suckler cows increased from the mid 1980s onwards in all members of the EU-15 except in the Netherlands, Denmark, Greece and Italy till it reached a plateau in the late nineties, when a national quota for the suckler cow premium was introduced. This indicates at least a partial replacement of dairy cattle by suckler cows. In response to the introduction of the ewe premium (Council Regulation EEC No 2644/80), sheep and goat numbers exploded in the mid and late eighties and remained at relatively high levels ever since (Cropper and Del Pozo-Ramoz, 2006) – excluding the effect of the foot and mouth disease on the British Isles, which also negatively affected the number of suckler cows.

In 1992, the Mac-Sharry Reform changed the principle of CAP (c.f. e.g. Cropper and Del Pozo-Ramoz, 2006). Price support was strongly reduced but flat payments per animal or per hectare were introduced as compensation. In addition, the EU spent more money on co-financing agri-environmental schemes, compensatory allowances and rural development measures (COM, 2004). The CAP-reform of 2000 was more or less the continuation of the previous one, with additional price cuts and an increase in compensation via coupled payments. The most recent CAP-reform was agreed in 2003. With this reform direct payments were largely decoupled and more funds were assigned to the second pillar, from which rural development and agri-environmental schemes to be paid.

In addition to changes in the agricultural support scheme, the EU also enlarged during this period. It grew from six mainly western to central European states to over 25 in 2004 covering large parts of the Continent. With respect to the ten new states (joining in 2004), it must be mentioned that in most states, but especially in Poland and the Baltic States, the roughage feeder populations crashed in the nineties. Between 1991 and 2004, the sheep population shrank by up to 80% and cattle numbers dropped by over 50% (EUROSTAT, 2005a; FAOSTAT 2006).

#### **D) Mechanisms of the 2003 reform**

Before looking at the 2003 reform in detail, it should be noted, that while the CAP reform changed the conditions for livestock farming in Europe, other political decisions also had an impact. First of all, in 2004 ten new member states (NMS) joined the EU and in most cases the farmers in these states are getting substantial financial support for the first time. This support is granted via direct payments and rural development schemes. Furthermore, prices for most agricultural products in EU-15 are higher than in the 10 NMS, so domestic prices increased substantially (e.g. USDA, 2006b). Secondly, some regulations of the 2000 reform were not set in force before 2005 mainly in the dairy sector where the intervention price was lowered for milk and the amount of milk quota expanded.

The CAP-reform of 2003 is partly a continuation of the previous ones with some new principles (Council Regulation (EC) No 1782/2003, Commission Regulation (EC) No 796/2004 and (EC) No 795/2004). The reform is based on four major principles:

- Decoupling,
- Cross-compliance (CC),
- Modulation,
- And 're-nationalisation'.

Decoupling of the payments means that the premiums are not linked anymore to any specified forms of production (e.g. special male or suckler cow premium). Instead the payment is linked to eligible area. Consequently the use of permanent pasture is not anymore indirectly supported via animal payments but directly via the area payments.

The second principle 'cross-compliance' means that the farmers must comply with a set of EU-regulations on environmental protection, animal welfare and disease control in order to

receive the payments. With respect to pastoral systems, the most decisive ones are the Council Directives 92/43/EEC (Habitats directive), 79/409/EEC (Wild birds directive) and 91/676/EEC (Nitrates directive). The enforcement of the latter will mainly concern farms with high stocking densities. With respect to farming with roughage feeders, the majority of these farms are intensive dairy farms. The Wild birds and the Habitats directive will be more relevant in marginal areas, since they cover more than 10% of the terrestrial surface of the EU and are concentrated in areas marginal from an agricultural point of view (COM, 2006b). However, in some areas, such as the Famenne and Jurassic areas in Belgium, more than 25 % of the surface is concerned by Wild birds and the Habitats directive with, in some municipalities of these areas, more than 50% of the permanent grasslands, covering more than 80 % of the utilized agricultural area (UAA), are concerned.

Aside from these directives, farmers must comply with a set of 'good agricultural and environmental practices'. Among them is the obligation to maintain the proportion of permanent grassland that was farmed during the reference period. This measure, together with the decoupling of silage maize premium, is very importance to support grassland based roughage feeder production (Le Gall and Raison, 2005).

Modulation means that money from the first pillar (direct payments) is retained and spent in the second (rural development, agri-environmental schemes). Up to 5% of the national payments for the first pillar must be redirected to the second. But the intention to strengthen the second pillar was partly sacrificed by the European Council in December 2005 when the rural development funds were cut back in order to achieve budget consolidation (CEU, 2005). This cutting in the expenditure of the second pillar is mainly borne by the EU-15 countries with the exception of Austria.

In contrast to the first three principles which are explicitly mentioned in the regulation, the 're-nationalisation' is the consequence of the implementation process. With this reform of the CAP, national and regional governments gained some autonomy as the reform contained many loosely defined terms which they could specify for themselves and the policy explicitly offers an array options on how to implement the directives. First of all, the governments could decide within certain limits which premiums they want to decouple and what proportion of the payments should remain coupled. Furthermore, they could choose among different options on how to (re-)distribute the decoupled payments among the farmers. Among the terms whose implemented definition varies significantly across the members are 'good agricultural and ecological condition' (GAEC) and 'eligible area'. These definitions have a significant impact on the standards the farmers have to meet in order to receive the payment. While the first relates mainly to the obligations the farmers have to fulfil, the second determines the size of the area for which funds can be claimed. Further, the reform offers the members the option to shift, additionally to the compulsory modulation, up to 10% of the money spent in the first pillar to the second. Finally, the intended promotion of second pillar strengthened the role of regional and national authorities since they design the respective schemes.

## **E) Implementation of the reform**

Since the members widely used the flexibility offered by the CAP reform one cannot assess its consequences without considering its implementation. With respect to the extent of decoupling one can differentiate this into three groups. The first and the largest opted for a full decoupling of all payments related to livestock husbandry (Figure 3). The second group, mainly Scandinavian countries, let premiums coupled which promote more intensive forms of farming, in order to stabilize domestic beef production. In all countries of this group, the special male premium is by far more important than the slaughter or the ewe premia. In the third group of countries, premia linked to more extensive forms of farming remained coupled.

These countries primarily intend to stabilize livestock husbandry in more or less adverse conditions.

With respect to the distribution of funds, two pure forms and a hybrid version of payments were implemented. While most members opted for the historical model, meaning each farmer receives the same amount of premiums claimed in a reference period as long as the extent of eligible area does not change. England, Germany and Finland implemented a regional model, resulting in a flat rate payment per ha of eligible land. With a regional model a redistribution of funds is associated. Especially farms who received high amounts of premia before the reform (e.g. intensive bull fattening farms), will lose premia while others, who received smaller payments (e.g. dairy cattle farms on pastoral land), will gain. The new member states had to implement the regional premium.

Decoupling	Coupled premia	Implemented model		
		Historic	Hybrid	Regional
<b>Fully</b>		UK (Wal, Sco), GR, IE, IT	LU	NMS10, UK (Eng), DE
<b>Partly</b>	Slaughter and special male premia	NL	SE	
	Special male and ewe premia		DK	FI
	Suckler cow premium	BE (Wallonia)		
	Suckler cow and slaughter premia	AT, BE (Flanders)		
	Suckler cow, ewe and slaughter premia	FR, PT, ES		

Figure 3. Implementation of the decoupling in the grassland related sectors throughout Europe.

Source: COM (2006a)

## F) Expected and Observed reactions on agricultural markets

The following section gives an overview of the expected effects of the CAP reform. First, we highlight the underlying reason for the changes. Second, we present some model results and finally, we check whether the available empirical data confirm the short-term expectations.

It is generally assumed that the 2003 CAP reform will lead to a decline in livestock. Figure 4 helps to understand the underlying basic assumption. According to economic theory, agents like farmers expand their production to the point where marginal revenues equal marginal costs. Simplifying, one can assume that the market revenues per animal are independent of the stocking, e.g. animals are always fattened to the same weight. Furthermore, one can assume that with increase in livestock this means, in the context of a constant farm size, increasing stocking density, the marginal costs per animal rise, as either the land must be managed more intensively or concentrates and fodder must be bought. The animal premia before the decoupling were proportional to the stocking, till a maximum value. Therefore  $x_{pre}$  was the maximum stocking density that could receive premia. With decoupling, the premia are linked to some other indicators (historic reference, farmed area) but not livestock. Hence, under decoupling the decision to produce or to stock animals is independent of the amount of premia a farmer receives, making  $x_{post}$  the optimal choice.

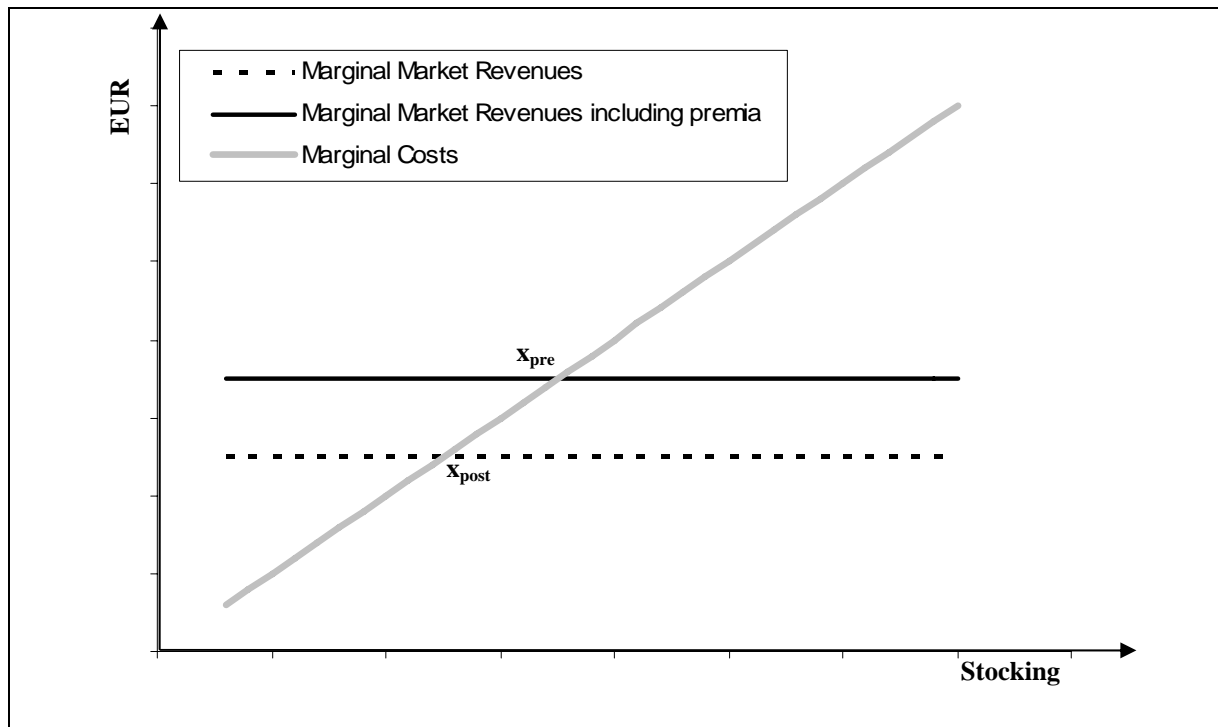

Figure 4. Impact of a decoupling on the extent of production.

Source: own presentation

In terms of looking forward, many ex-ante analyses have been conducted. Partial equilibrium models have been widely used to analyse the effect of decoupling on commodity markets. These models project the effects of decoupling on commodity prices, volumes of production and trade, and on many other economic indicators. One such model is the FAPRI EU GOLD model (Binfield *et al.*, 2006). The FAPRI analysis projects that dairy product prices will decline as a result of the intervention price cuts agreed in the 2003 reform. The EU cheese price is projected to decline by 5%, the butter price by 23% and the EU skimmed milk powder by 8% from 2004 to 2015. It is projected that the EU milk quota will continue to be filled but that the total number of dairy cows in the EU will decline as productivity per cow increases and the quota limit remains binding. As shown in Figure 5, FAPRI projects that dairy cow numbers will decline by slightly more than 10% between 2004 and 2015 in the EU25.

In relation to the beef sector, the decline in the suckler cow herd varies between member states depending on the decoupling scheme. The model projects that the EU suckler cow herd will decline quite quickly from 2006 to 2008 but recover after that and that by 2015; it is projected to be approximately 6% lower than 2004 level.

Associated with the decline in EU suckler and dairy cow herds, overall beef production is projected to decline by 9% between 2004 and 2015. The fall in supply in conjunction with steady demand for beef results in a price increase across the EU of, on average, 11% between 2004 and 2015.

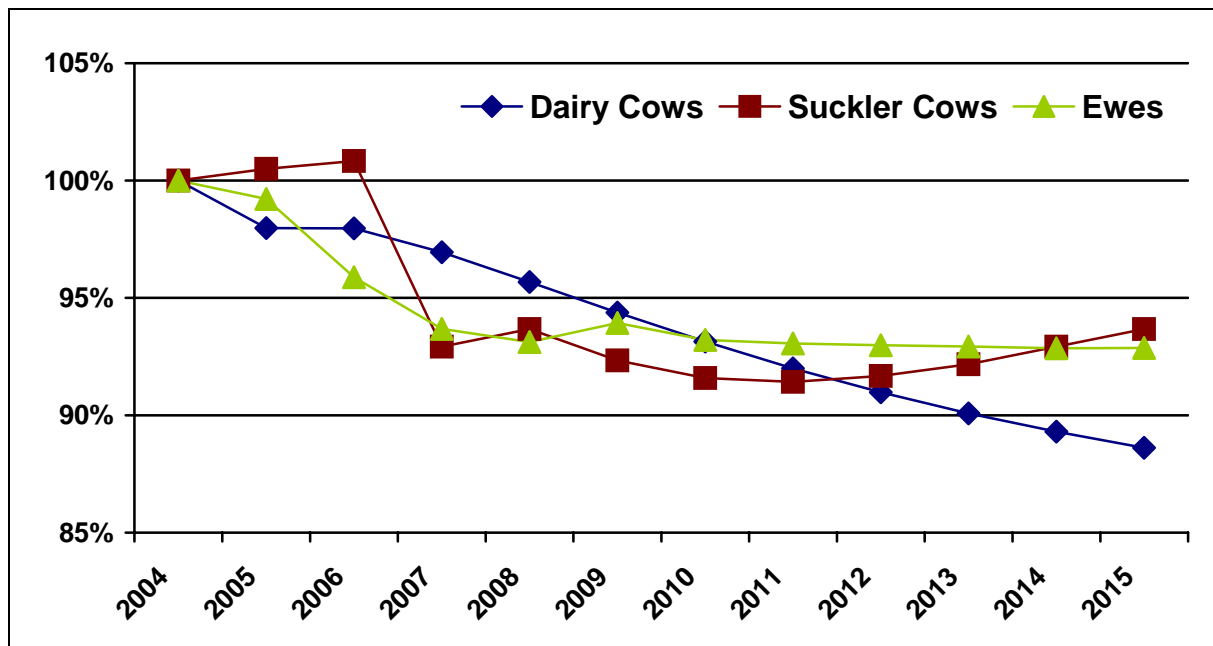

Figure 5: FAPRI Projections of Animal Numbers Following Decoupling in the EU15

Source: Binfield *et al.* (2006)

In relation to the sheep sector, the decoupling of ewe premia across the EU leads to declining ewe numbers that are projected to be 7% lower in 2015 than in 2004. Declining stocks of breeding ewes will lead to a decline in overall lamb production by an estimated 3% over the projection period. Again, similar to the beef sector, the fall off in lamb production induces a price increase of 14% on average across the EU.

The FAPRI estimates outlined above are just one of a number of estimates that have been produced on the effects of decoupling on agricultural markets. Like any other economic analysis, the estimates are of course sensitive to the assumptions invoked in the model and the methodology employed. Nevertheless, whatever model used (CAPRI, FAPRI, ESIM, AGLINK, GTAP and Agmemod), similar tendencies are observed with some variations of the predicted magnitude (Gohin, 2006). A review of economic models show that the estimated decline in the EU suckler cow herd varies from 9.5 to 3.2% depending on the model assumptions and the assumed supply inducing effects of decoupled payments. There is no great variation in the estimates of milk production due to the existence of the milk quota. With respect to the milk price, there is some variation in the model estimates from a reduction of 1.8% to 8.8%.

Taken the short period of time since the CAP reform, the empirical evidence for the proposed effects is generally meagre due to a lack of data or to the fact that the adaptation process requires some time. Looking at the Bavarian sales prices on the beef market and the slaughter volume one sees that the direction and magnitude of change goes along with projections (Figure 6). In contrast to Bavaria, where premiums were fully decoupled, the Belgian prices have hardly changed (SPF Economie, 2005).

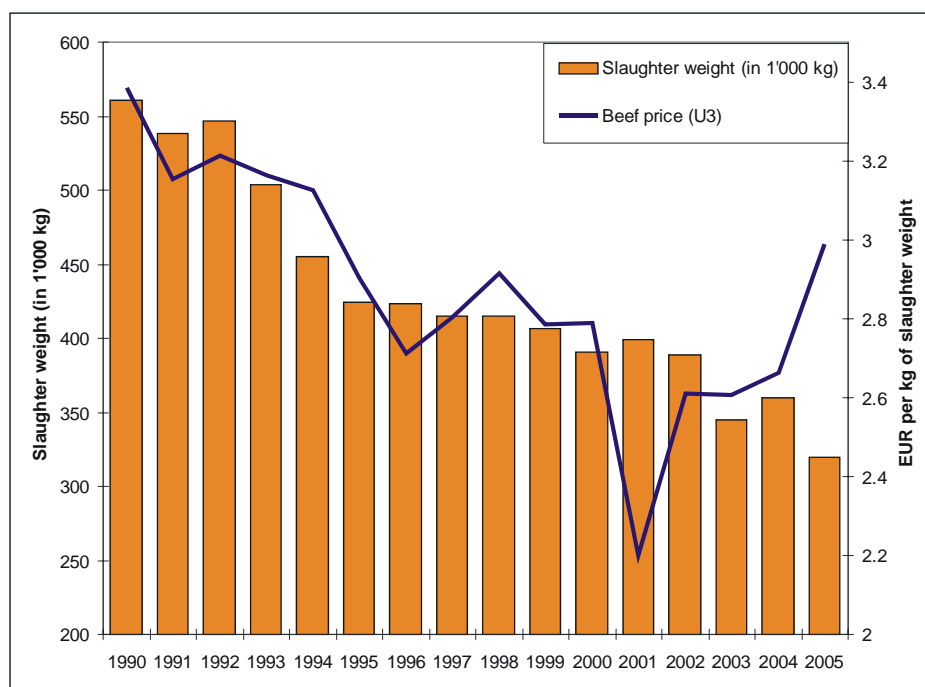

Figure 6: Development of the beef prices and beef slaughter volume in Bavaria. Source: BayStMELF (2000), BayStMLF (2004), LfL (2005)

### G) Other factors influencing the use of grassland in the EU

Before presenting the expected consequences of the CAP reform for the utilization of grassland in the different member states, the impact of other policies on the farmer's decision will be highlighted. Indeed, the type and intensity of livestock farming and the chosen implementation of the CAP-reform are two variables, but not the only ones. These variables cause the emergence or reinforce some heterogeneity at the regional level. In the context of the CAP reform, the first question the farmer faces is, for which area can he claim payments and must he therefore respect the CC-regulations. As mentioned, some of the grazed semi-natural plant communities do not fit into the EU definition of grassland and, therefore, do not account, in a strict sense, for the eligible area. In the case of full decoupling, one should consequently expect a strong decline of the grazing use. Based on CORINE-data these semi-natural habitats account for more than 10% of the TAL in many parts of the UK, Ireland, Spain, Greece, the Alps, Northernmost Finland and Sweden as well as in the Mediterranean part of France. However, some countries, as Spain, decouple animal premiums only partially while others, as the UK, are quite flexible with respect to the definition of grassland.

However, revenues in pastoral systems are not necessarily all about market revenues and payments of the 1<sup>st</sup> pillar of the CAP. The latter payments sum up to roughly 300 €/per ha, on average across the EU-15. Since large parts of pastoral livestock farming is concentrated in marginal areas (Pflimlin *et al.*, 2005), the Less Favoured Area (LFA) payment contributes significantly to the farm income (Figure 7). However, the less favoured area payments often require compliance with specified stocking densities.

		Proportion of TAL within less favoured areas (LFA)		
		less than 20%	20% - 60%	more than 60
Average Payment for land in LFA	less than 25 EUR per ha	BE, DK, NL	IT	ES, PT
	25 – 50 EUR per ha		FR, SE, UK, DE	
	more than 50 EUR per ha		IE	AT, GR, FI, LU

Figure 7: Importance of compensatory allowances in the EU-15.  
Sources: EEA (2004, 2005), EUROSTAT (2005c)

Like the LFA payments the payments in agri-environmental schemes (AES), including organic farming support, are in the majority of the cases linked to the compliance with specified stocking density or promote specified forms of land use. In countries like Germany, Ireland, and Austria a very significant part of these payments are dedicated to grassland-based farming systems (Hartmann *et al.*, 2006; Lebensministerium, 2003). In the same way, in Wallonia (Belgium), 87% of the area under conversion to organic farming is grassland (Direction Générale de l’Agriculture, 2005). In most countries, less area is enrolled in AES than in LFA schemes but more money is spent per ha (Figure 8).

		Proportion of TAL within agri-environmental schemes (AES)		
		less than 20%	20% - 60%	more than 60%
Average payment for land in AES	Less than 100 EUR per ha	ES	FR	SE, LU
	100 – 200 EUR per ha	BE, DK, PT, UK	DE	FI
	More than 200 EUR per ha	GR, IT, NL	IE	AT

Figure 8: Importance of Agri-environmental schemes in the EU-15.  
Sources: EEA (2004, 2005), EUROSTAT (2005c)

In addition to these differences in the agricultural support policies the natural conditions are diverse making in certain areas some forms of land use more sensible than others, e.g. mowing or mulching steep and rocky slopes in an alpine setting will always be more expensive than let the area to be grazed. Furthermore, some technically feasible options of keeping the landscape open might be legally prohibited, e.g. burning in some regions. The legally feasible set of alternatives largely depends on the national or in some states regional definition of GAEC. While most countries only implemented the minimum standards demanded by the EU-Commission, a few member states go beyond this minimum level and implemented with the GAEC standards a ‘light’ version of an agri-environmental scheme (Farmer and Swales, 2004).

Another aspect which must not be forgotten in this context is that management restriction imposed by the NATURA 2000 management plans become compulsory for the farmer. Since NATURA 2000 sites often aim at preserving semi-natural vegetation communities, they include, when agricultural land is concerned, a majority of natural or semi-natural grasslands. So the restrictions linked to these areas are of high relevance for grassland farming. On the one hand, in areas with a high proportion of land included in NATURA 2000 network, the constraints on land management can represent an important brake to the development of different agricultural activities such as the dairy production. On the other hand, these management rules may be considered as an opportunity for farmers. Some farmers may



choose to adopt alternative production practices to differentiate their products and supply a niche food market. This may allow farmers to use this more stringent set of restrictions, which are monitored via IACS, to promote their specific products and production practices thus offering a more value-added product.

Furthermore some countries like Ireland and France use their national milk quota distribution scheme to stabilize and promote dairy farming in marginal areas. Last but not least, it should be mentioned that the raising costs for fossil fuels and the generous support in some member states initiated a Bonanza of the cultivation of Bioenergy crops. In Germany, the cultivation of silage maize for methane production intensely competes with its cultivation to feed livestock. Here, this new activity promotes the concentration of cattle farming in grassland areas.

## **H) Expected consequences for the land use on the national and regional levels**

The previous chapters show that a plethora of effects and measures are influencing the utilization of grassland at the regional scale. As the relevance of these factors varies from one region to the other, an expert survey was conducted in autumn 2006, in order to get an overview of the recent and expected changes based on local knowledge. The information gained from the questionnaires was complemented by a literature review. Of the EU 25 countries no answers were received from Italy, the Baltic States, Slovakia, Luxemburg, Malta and Cyprus. For Poland and Spain, the information given by the experts refers only to certain regions (Carpathians, and Extremadura and Castilla-La Mancha).

Despite the regional variations, a somewhat homogenous pattern emerges. In regions where low productive arable farming systems are predominant, average annual yields below 3 t DM / ha, some conversion of arable land to permanent grasslands (sown or self seeded) and the extension of ley-farming are expected. This expectation refers mainly to unirrigated sections of the Iberian Peninsula, Greece and southern France (e.g. Institut de l'élevage, 2006). Before the 2003 CAP reform, arable farming in these areas often yielded negative gross margins, if premia are not accounted for, and extensive meat oriented animal husbandry system can often fulfil the GAEC standards at lower costs. While the extent of grasslands is going to increase the management intensity is quite likely to decrease (e.g. da Silva Carvalho and de Lurdes Ferro Godinho, 2006). For meat-oriented systems, an increase in the relevance of pastoral resources in the diet is likely. In France and the Iberian Peninsula, especially the non-decoupled suckler cow and the partly decoupled sheep premia will stabilize animal numbers, while in Greece the raising market revenues stabilize the population of small ruminants. Furthermore the good market conditions for high value products such as the Iberian pig promote an extensive grazing system in the Montado and Dehesa. Looking at dairy farms, the picture is different. In the case of dairy farming, cattle as well as sheep, the increasing size of the holdings in addition to structural constraints related to the access of pastoral resources, will promote the shift towards indoor feeding systems. This will lead to a lower valorisation of the pastoral resources. The respective areas however have to be kept in GAEC in order to claim the first pillar payments. Under more favourable conditions like in the Northern parts of the Iberian Peninsula or in irrigated river valleys, an intensification of forage production is likely. This is typical for most Mediterranean countries, where a reallocation of dairy farming from grassland areas to irrigated arable areas is generally expected.

Regarding the conversion, similar trends are forecasted for the marginal arable regions of the UK and Ireland, where farms have an above average reliance on direct payments. It is expected that some land will move out of cereal production and into extensive land use. The high reliance of cereal producers on direct payments means that a reduction in cereal production is expected. A number of cereal producers who will no longer find production

profitable, are expected to shift their arable land to pasture and maintain a low stocking density sufficient to comply with the good agricultural practice requirement.

Looking at low yielding grassland regions, the picture is slightly different. These areas cover large sections of the northern and western British Isles, the Central and Eastern European mountain regions and the northern parts of Finland and Sweden. Generally, the decoupling leads to declining stocking density in these areas. However, the newly established link of the payment to the area limits the likelihood of abandonment. On the British Isles, Wallonia, France and to a smaller degree in Austria, these marginal grasslands are mainly utilized by sheep and suckler cows. All the respective countries and regions but England opted for a historic decoupling approach. In Wallonia, Austria and France, most ruminant related premia remain coupled so the effect of decoupling will be rather small. Furthermore, in Austria, grassland farming in marginal areas is well supported by agri-environmental payments. For those marginal areas where grassland was mainly utilized by dairy cattle, the picture looks slightly different. In Finland and Germany, where the utilization of grassland is frequently linked to dairy farming, both opted for a regional premium. This implies a redistribution of public funds to marginal areas that in turn will stabilize livestock husbandry on grassland. As Austria has an intermediate position with respect to the utilization of grassland, some remarks on the dairy sector must be made. It is expected, that the milk production in Austria will remain stable in volume of production (Kirner, 2004), but the dairy farms will be run with a declining intensity. In the productive arable regions, beef production will decline (Schmid and Sinabell, 2004). While the 2003 CAP reform will slow down some trends, it will especially in Austria and Finland not prevent the abandonment of the most distant and marginal grassland areas associated with the termination of small dairy farms (for Finland: Lehtonen, 2004). With respect to dairy farming, a similar trend is forecasted for the UK and Ireland.

In countries or areas with a high potential yield such as the Netherlands, Denmark, Belgium, the Nitrates directives promotes the conversion of arable land to grassland since the directive permits higher stocking densities on grassland than on arable land. Also in the more intensively used parts of Germany and France, the CC conditions require an extensification of the land use especially for intensive dairy farms. For these farms, the compliance with stocking restrictions becomes for the first time financially relevant. In consequence, the relevance of grass in the diet of the ruminants will remain constant or increase even in high yielding flocks. In Germany, dairy farming currently moves from arable regions to areas with a high percentage of permanent grassland. This development can be traced back to two reasons. Firstly, in the event of a family turnover, many heirs switched from full time dairy farming to part time cash cropping, which yields a higher hourly remuneration. Secondly, the financial promotion of biogas created a new alternative for those farms located in areas with highly favourable conditions for silage maize.

The enlargement of 2003 will in most of the new member states stabilize livestock husbandry especially in marginal areas for a couple of reasons. Firstly, the farmers got access to direct payments which increase the value added of farming. Secondly, the agricultural commodity prices in the old members are higher than the ones in the new and it can be expected that the differences will decline over time. For the Czech Republic, Hungary and the Carpathian part of Poland, it is expected that the utilization intensity of grassland will be unaffected but the extent of grassland in agricultural use will raise especially in the most marginal areas. For Slovenia, the experts regard an intensification of the grassland use as the most likely option, while the extent of grassland is going to decline. Apart from Poland, milk production is expected to retreat from grassland areas.

The Netherlands, Sweden, Denmark and Finland promote the national beef sector and slaughterhouse activities by keeping some of the beef related premia coupled. In these countries the beef production is nearly exclusively linked to the offspring of the dairy herd

therefore the slaughter and the special male premium are the measures of choice. On the other hand, beef production in Ireland, where all premiums are completely decoupled from production, is expected to decline. A large number of livestock farmers in Ireland were operating at a market loss prior to decoupling, that is the market price received for animals at slaughter was insufficient to cover the costs of production. When this payment is no longer linked to production it is expected that a large number of farmers will reduce the number of animals they have on their farms. Due to the complete decoupling of direct payments a decline in the national suckler cow herd is expected. It is projected that the national suckler cow herd will decline by 14% from 2004 to 2015. This leads to a decline in the beef breeding herd. Total beef production in Ireland is expected to be almost 20% lower in 2015 compared to 2004. The UK also decoupled the suckler cow premium and as a result the suckler cow herd in the UK is also expected to decline. According to a FAPRI study, the UK suckler cow herd will decline by 18% by 2010 due to decoupling. This results in total beef production declining by 10%.

Povellato and Velazquez (2005) assess the impact of the CAP reform as being very limited in Italy. They expect that the southern parts will be stronger affected than the northern ones. All in all they expect that the size and the composition of the ruminant herd will remain constant with the exception of a small decline in the number of goats and suckler cows. In many areas, grassland use will be extensified to a level which ensures they fulfil of the GAEC standard. In certain regions, like in Southern Tyrol the regional GAEC standards demand a minimum stocking densities for grassland of 0.4 LU / ha (Abl., 2006). Italy limited the impact of the reform by setting very restrictive regulations for the trading of payment entitlements (cf. D'Andrea; 2006).

In many European countries, one observes an extension of dairy holdings, even if, in response to the increasing milk yields per animal, the national stocks of dairy cattle continuously decline e.g. in Belgium by roughly 3% per year (SPF-Economie, 2005) and in Ireland by approximately 1.5% per year (Teagasc, 2004). However, with increasing milk yields per cow that national dairy herd will decline. These developments, rising per capita yield and herd size, are not unproblematic for the future utilization of grassland, especially, if the competitive farms are located in grassland dominated areas. On the one hand, the area premium sets a strong incentive for the farmer to maintain the farmed acreage at the current extent. On the other hand, with the increasing per capita yield of the herd, a farmer needs fewer and fewer animals to produce his milk contingent. In principal he has two options. He can either destock and extensify the use of his grassland or he can purchase additional milk quota and keep a constant number of dairy cattle. However, using the destocking option is problematic since a reduced management intensity in grassland is often accompanied by a declining quality of the fodder. If the farmer uses the productive progress with a constant herd size the obligations of the Nitrates directive become increasingly relevant, since some countries adjust the feasible stocking levels by the herd's average milk productivity. Looking at the other development the increasing herd size, one must be aware that the farmers become increasingly labour-restricted. This means they either shift from grassland to silage maize as fodder base, or the abandonment of smaller and more distant plots. In this context, the promotion of steer or heifer production represents an alternative at least for farms with a fraction of their land included in NATURA 2000 areas. However, extensive grazing systems must be operated labour extensively in order to allow an economic operation. This means the use of breeds or crossbreeds that demand a low level of surveillance and larger unfragmented plots. This last precondition is often not met in Central European low mountain areas.

## **D) Summary and Conclusions**

Summarising the results above, one can argue that decoupling leads to reduced number of animals since the production may be abandoned or reduced in areas where only the premia turn the production profitable. However, the 'accompanying' measures like Cross-compliance, the GAEC requirement or the NATURA 2000 scheme stabilize the area utilized by roughage feeders. Cross compliance will have its strongest effects in the most intensively used regions. Here it sets tight limits on the conversion of grassland to arable land and further limits the intensity of utilization. With the milk premium, the high intensity dairy farms derive for the first time a non-negligible part of their income from direct payments. This makes in most countries the compliance with the respective CC restriction for the first time an economic relevant issue for high intensity dairy farms. The requirement to keep the land in good agricultural and ecological condition, in order to receive direct payments, will ascertain a certain minimum stocking in most marginal areas while it makes the conversion of the least productive arable land of the EU into permanent grassland more likely, but only if the regional plot structure and the climate permit the cost efficient operation of pastoral activities. The impact of the NATURA 2000 scheme is limited in most countries. However, the management requirements set boundaries on the possible levels of extensification and / or intensification especially in more marginal areas.

In order to stabilize the utilization of grassland in marginal areas of the EU 15, most of the members implemented one of the following four different strategies, or a combination of them. The first was to set very tight GAEC standards which actually require some form of livestock husbandry on grassland in order to receive the direct payments (e.g. IT, UK). The second option was to keep coupled the premia which are related to extensive form of animal husbandry (Figure 2). The option for a regional implementation of the decoupling was the third strategy, from which especially extensively managed grassland regions benefit, where this grassland is used by dairy cattle (e.g. DE, FI). The last option is to promote extensive livestock husbandry systems via payments of the second pillar. Of the old member states, only Greece cannot be attributed to one of the groups.

The adhesion will generally stabilize grassland-based systems in the new member states. The farmers profit from the direct payments and the raising commodity prices.

One cannot argue that agricultural policy does not influence agricultural production. However, production decisions are not affected by policy only. This becomes especially apparent in the dairy sector. While in Eastern and Southern Europe, the production is still moving from grassland to irrigated arable land, an opposite trend can be observed in Central and Western Europe. Here dairy farming retreats to productive grassland areas, since on arable land the farmer have many alternatives which yield higher hourly profits. Furthermore, all over Europe, the national dairy herds are declining. At the same time each farmer keeps for economic reasons on average more and more animals and constantly increases the milk yields per cow. These developments make especially the integration of low productive grassland into dairy systems increasingly problematic.

While decoupling leads to a lower incentive for production the increasing agricultural commodity prices all over Europe after the decoupling give an incentive to stay in production. In 2005, the bull beef prices in 20 out of 23 EU countries exceeded by more than 5% the average of the five previous years (ZMP, 2006; EUROSTAT, 2006). In 16 countries, the prices increased by more than 10%. Only in the UK, Greece and Belgium, the prices stayed within their historic bandwidth, while no data was available for Cyprus and Estonia. When one looks at cow meat, the increase is even more pronounced. In 12 of the 14 old member states where cow meat is marketed, the prices rose by more than 10% (ZMP, 2006). The only exceptions are Portugal, Greece and Ireland. Due to BSE, no cow meat was sold in the U.K.

The beef prices in the UK rose by 40% from autumn 2005 till autumn 2006 after trading limitations related to BSE were lowered (Elliot, 2006). In the EU, the beef prices in 2006 even exceeded the level of 2005 (USDA, 2006a). In 2005, only in Greece, Slovakia, Portugal and Hungary, the prices for sheep products (meat and milk) rose markedly (EUROSTAT, 2006). One can argue whether this price shift can be attributed to a reduced transmission of the coupled premia to the meat processors, or to external effects as the severe drought in Australia, the Argentinean export ban on beef, the outbreak of the food and mouth disease in Brazil or the changing consumption patterns in India and China.

Apart from the developments on the classical agricultural market, some new development are influencing the agricultural production across Europe. In Portugal, the conversion of arable land to grassland is financially supported by electricity companies as a mean of carbon sequestration. Furthermore, the rising costs of fossil fuels do not leave the agricultural sector unaffected. The production of bioenergy, especially of biogas, strongly competes with animal husbandry for silage maize in Germany or grass in Finland. A more intensified competition is quite probable for the future. An indicator is the price per energy equivalent of different resources. In Germany, the respective price of straw was below the one of timber in winter 2006/07 - both of them being significantly cheaper than oil.

Given the relatively short time interval since decoupling has actually been implemented (January 2005) it is still very early to state with any confidence the effects of the policy reform on production and animal numbers or to comment on the accuracy of predictions made before the implementation of the policy. Notwithstanding this, indications to date seem to suggest that the relatively high prices that have prevailed for most commodities since the implementation of the 2003 CAP reform may mean that the depopulation of animals may not be as widespread as was originally forecasted. The current situation with high prices for agricultural products creates a window of opportunity in which the payments for the first pillar could be reduced. Especially in marginal areas, the higher market prices may not still be sufficient to encourage production after decoupling, but they may be an impetus for an additional intensification in productive regions (cf. the situation before the MacSharry reform in 1992). However, the longer-term development of the agricultural markets in the EU is uncertain. On one hand, the increasing demand for bioenergy, the declining proportion of self-sufficiency for many agricultural products and the increased consumption in developing countries might induce higher or at least stable prices within the EU. On the other hand, world trade reform policies coupled with growing pressure on the EU budget due to the enlargement of the community is likely to further erode price support and expedite the downward trend in commodity prices. A further erosion in the profitability of production is likely to lead to the extensification or abandonment of production in marginalised agricultural areas of the community. However, as long as some payments remain coupled to compliance with some minimum GAEC standards most areas will stay in some form of minimal use. The environmental and societal implications of this potential extensification of agriculture are both positive and negative. While a reduced stocking might lead in the Black Forest to the abandonment of the last meadows in the valley floors, a reduced stocking in marginal areas where the stocking is quite high like the Ardennes might be assessed as being beneficial or at least neutral. One method of ensuring the continuation of agricultural production in marginal areas is to use pillar II funds to support these regions. Pillar II is more flexible and is designed at the regional level, therefore it allows for a better targeting of the funds in order to address the specific problems of a certain region. However, it should be noted that any payment that is linked to production, funded from pillar I or II, is still regarded as a 'blue-box' payment in the WTO and therefore may not be sustainable in the long term. Actually, in many marginal areas it is at least doubtful whether farmers adapt their production intensity in order to comply with

the demands of pillar II programs or whether these payments allow just more producers to stay in production.

## References

- United States Department of Agriculture(USDA) United States Department of Agriculture (USDA) (2006a) EU-25 Livestock and Products Annual 2006 <http://www.fas.usda.gov/gainfiles/200607/146208314.pdf>. GAIN Report E36107. last update: 14.07.2006.
- (USDA) United States Department of Agriculture United States Department of Agriculture (USDA) (2006b) Poland Livestock and Products - Development of Beef Industry in Poland 2006. [http://www.stat-usa.gov/agworld.nsf/505c55d16b88351a852567010058449b/0d68ac5d31232d5b8525714d006f1607/\\$FILE/PL6022.PDF](http://www.stat-usa.gov/agworld.nsf/505c55d16b88351a852567010058449b/0d68ac5d31232d5b8525714d006f1607/$FILE/PL6022.PDF). GAIN Report PL6022. last update: 04.07.2006.
- Abl. (Amtsblatt der autonomen Region Trentino Südtirol) (Abl) Beschluss der Landesregierung vom 27. Februar 2006, Nr. 676 zur Festlegung der auf territorialer Ebene anzuwendenden Verpflichtungen laut Dekret Nr. 4432 vom 15.12.2005: «Disciplina del regime di condizionalità», Beiblatt Nr. 1 zum Amtsblatt vom 11.4.2006 - Nr. 15/I-II, <http://www.regione.taa.it/giunta/bu/2006/parteprimaseconda/bupdf/S1150601.pdf>. Trento, p. 58-84.
- BayStMELF (Bayerisches Staatsministerium für Ernährung, Landwirtschaft und Forsten (BayStMELF) (2000) Bayerischer Agrarbericht 2000. München.
- BayStMLF (Bayerisches Staatsministerium für Landwirtschaft und Forsten (BayStMLF) (2004) Bayerischer Agrarbericht 2004. München.
- BfS (Bundesamt für Statistik (BfS) (2006) Tierbestand 2003. <http://www.agr.bfs.admin.ch>. lastly accessed 20.02.2006.
- Binfield J., Donnellan T., Hanrahan K. and Westhoff P. (2006) World agricultural trade reform and the WTO Doha Development Rounds: Analysis of the impact on EU and Irish Agriculture. *Teagasc, Rural Economy Research Centre Athenry*, p. 1-96.
- CEU (Council of the European Union (CEU) (2005) Financial Perspective 2007-2013. [http://ue.eu.int/ueDocs/cms\\_Data/docs/pressData/en/misc/87677.pdf](http://ue.eu.int/ueDocs/cms_Data/docs/pressData/en/misc/87677.pdf). last update 19.12.2005.
- Clerc F. (1964) Le Marché Commun Agricole. Presses Universitaire de France. 127 p.
- COM (European Commission (COM) (2006b) Sites of community importance. [http://ec.europa.eu/environment/nature/nature\\_conservation/useful\\_info/barometer/pdf/sci.pdf](http://ec.europa.eu/environment/nature/nature_conservation/useful_info/barometer/pdf/sci.pdf), last updated 20.06.2005.
- Cropper M. R. and Del Pozo-Ramos M. (2006) Impacts of CAP reform on animal production systems. Lloveras J., Gonzales-Rodriguez A., Vazquez-Yanez O., Pinero J., Santamaria O., Olea L. and Poblaciones M. J. (eds.) Sustainable Grassland Productivity. Proceedings of the 21th General Meeting of the European Grassland Federation, Badajoz (Spain), 3. - 6.04.2006; Grassland Science in Europe 11, 615-623.
- D'Andrea M. R. P. (2006) Le politiche agricole dell' unione europea, Rapporto 2004-05. <http://www.inea.it/pdf/pac2005/cap10AppPAC2005.pdf>. Istituto Nazionale di Economia Agraria. Rome, p. 423
- da Silva Carvalho M. L. and de Lurdes Ferro Godinho M. (2005) Consequences of the 2003 CAP reform on a Mediterranean agricultural system of Portugal. [http://agecon.lib.umn.edu/cgi-bin/pdf\\_view.pl?paperid=18094&ftype=.pdf](http://agecon.lib.umn.edu/cgi-bin/pdf_view.pl?paperid=18094&ftype=.pdf). Poster presented at 11th Congress of the European Association of Agricultural Economists, Copenhagen, Denmark.
- Direction Générale de l'Agriculture (2005) Evolution de l'économie agricole et horticole de la Région Wallonne en 2003. V. Thomas (ed.), Namur, Belgique.
- EEA (European Environmental Agency (EEA) (2004) High nature value farmland: Characteristics, trends and policy challenges. EEA-report 1 / 2004. Copenhagen, 32 pp.
- EEA (European Environmental Agency (EEA) 2005 Agriculture and environment in EU-15 - the IRENA indicator report. EEA-report 6 / 2005. Copenhagen, 128 pp.
- Elliott V. (2006) Now premium quality beef costs more than foie gras. The Times. issue from 23.09.2006. <http://www.timesonline.co.uk/article/0,,2-2370947,00.html>. London.
- European Commission (COM) (2004) The common agricultural policy explained. [http://ec.europa.eu/agriculture/publi/cap\\_en.pdf](http://ec.europa.eu/agriculture/publi/cap_en.pdf), lastly accessed 1.7.2006.
- European Commission (COM) (2006a) Overview of the implementation CAP reform (first and second wave of the reform). [http://ec.europa.eu/agriculture/markets/sfp/ms\\_en.pdf](http://ec.europa.eu/agriculture/markets/sfp/ms_en.pdf), lastly modified at the 19.04.2006.
- EUROSTAT (Statistisches Amt der Europäischen Gemeinschaften (EUROSTAT) (2005a) Animal populations (December). <http://epp.eurostat.cec.eu.int>. last update 9.12.2005.
- EUROSTAT (Statistisches Amt der Europäischen Gemeinschaften) Statistisches Amt der Europäischen Gemeinschaften (EUROSTAT) (2005b) Areas harvested, yields, production. <http://epp.eurostat.cec.eu.int>. last update 07.10.2005.

EUROSTAT (Statistisches Amt der Europäischen Gemeinschaften) Statistisches Amt der Europäischen Gemeinschaften (EUROSTAT) (2005c) Structure of agricultural holdings by region, main indicators. <http://epp.eurostat.cec.eu.int>. last update 12.07.2005.

EUROSTAT (Statistisches Amt der Europäischen Gemeinschaften) Statistisches Amt der Europäischen Gemeinschaften (EUROSTAT) (2006) Selling prices of animal products (absolute prices). <http://epp.eurostat.cec.eu.int>. last update 28.12.2006.

FAOSTAT (2006) Data on sheep and cattle population. <http://faostat.fao.org/faostat/collections?version=extandhasbulk=0andsubset=agriculture>. Last update on the 24.04.2006.

Farmer M. and Swales V. (2004) The development and implementation of cross compliance in the EU 15- an analysis. [http://www.birdlife.org/news/pr/2005/05/birdlife\\_cross\\_compliance\\_report.pdf](http://www.birdlife.org/news/pr/2005/05/birdlife_cross_compliance_report.pdf). last update: 24.05.2005, London, p. 84.

Gohin A. (2006) Assessing CAP reform: Sensitivity of modelling decoupled policies. *Journal of Agricultural Economics*, 57, No. 3

Hartmann E., Frieder T. and Luick R. (2006) Agrarumweltprogramme in Deutschland – Anreiz für umweltfreundliches Wirtschaften in der Landwirtschaft und Kooperation mit dem Naturschutz. *Naturschutz und Landschaftsplanung* 38 (7), 205-213.

Institut de l'élevage (2006) L'élevage français à l'horizon - Quelles évolutions possibles après la réforme de la PAC? <http://www.ofival.fr/cd-03-06/pac-2012/Rapport-final.pdf>. Paris, p. 101.

Kirner L. (2004) Ökonomische Auswirkung der GAP-Reform 2003 auf Milchkuhbetriebe in Österreich – Versuch einer Quantifizierung. *Berichte über Landwirtschaft*, 58-80.

Le Gall A. and Raison C. (2005) Impacts de la conditionnalité environnementale des aides de la Politique Agricole Commune sur les systèmes laitiers français. Collection Résultats – Institut de l'Élevage, compte rendu 19053301, 29 p.

Lebensministerium (2003) Evaluierungsbericht 2003 – Halbzeitbewertung des Österreichischen Programms für die Entwicklung des ländlichen Raums. <http://www.lebensministerium.at/filemanager/download/5747>. Last update: 28.01.2004, Wien. p. 309.

Lehtonen H. (2004) Impact of de-coupling agricultural support on dairy investment and milk production volume in Finland. *Acta Agriculturae Scandinavica, Section C – Economy* 1 (1), p. 46- 62.

LfL (Bayerische Landesanstalt für Landwirtschaft (LfL) (2005) Agrarmärkte Jahresheft 2005 – Teilauszug Rinder. München.

Official Journal L. Commission Regulation (EC) No 795/2004 of 21 April 2004 laying down detailed rules for the implementation of the single payment scheme provided for in Council Regulation (EC) No 1782/2003 establishing common rules for direct support schemes under the common agricultural policy and establishing certain support schemes for farmers (Official Journal L 141, 30/04/2004 P. 0001 – 0017).

Official Journal L. Commission Regulation (EC) No 796/2004 of 21 April 2004 laying down detailed rules for the implementation of cross-compliance, modulation and the integrated administration and control system provided for in of Council Regulation (EC) No 1782/2003 establishing common rules for direct support schemes under the common agricultural policy and establishing certain support schemes for farmer (Official Journal L 141, 30/04/2004 P. 0018 – 0058).

Official Journal L. Council Directive 75/268/EEC of 28 April 1975 on mountain and hill farming and farming in certain less- favoured areas (Official Journal L 128, 19/05/1975 P. 0001 – 0007).

Official Journal L. Council Directive 79/409/EEC of 2 April 1979 on the conservation of wild birds (Official Journal L 103, 25/04/1979 P. 0001 – 0018).

Official Journal L. Council Directive 91/676/EEC of 12 December 1991 concerning the protection of waters against pollution caused by nitrates from agricultural sources (Official Journal L 375, 31/12/1991 P. 0001 – 0008).

Official Journal L. Council Directive 92/43/EEC of 21 May 1992 on the conservation of natural habitats and of wild fauna and flora (Official Journal L 206, 22/07/1992 P. 0007 – 0050).

Official Journal L. Council Regulation (EC) No 1782/2003 of 29 September 2003 establishing common rules for direct support schemes under the common agricultural policy and establishing certain support schemes for farmers and amending Regulations (EEC) No 2019/93, (EC) No 1452/2001, (EC) No 1453/2001, (EC) No 1454/2001, (EC) 1868/94, (EC) No 1251/1999, (EC) No 1254/1999, (EC) No 1673/2000, (EEC) No 2358/71 and (EC) No 2529/2001 (Official Journal L 270, 21/10/2003 P. 0001 – 0069).

Official Journal L. Council Regulation (EEC) No 2644/80 of 14 October 1980 laying down general rules for intervention with regard to the sheepmeat and goatmeat sector (Official Journal L 275 , 18/10/1980 P. 0008 – 0010).

Pflimlin A., Buczinski B. and Perrot C. (2005) Proposition de zonage pour préserver la diversité des systèmes d'élevage et des territoires européens. *Fourrages*, 182, 311-330.

- Povellato A. and Velazquez B. E. (eds.) (2005) La riforma Fischler e l'agricoltura italiana. <http://www.inea.it/pubbl/fischler.pdf>. Istituto Nazionale di Economia Agraria. Rome, p. 185.
- Schmid E. and Sinabell F. (2004) Implications of the CAP Reform 2003 for Rural Development in Austria. [http://www.boku.ac.at/wpr/wpr\\_dp/dp-06-2004.pdf](http://www.boku.ac.at/wpr/wpr_dp/dp-06-2004.pdf). Discussion paper DP-06-2004 of the Institut für nachhaltige Wirtschaftsentwicklung, Wien.
- SPF Economie – Direction générale Statistique (2005) – [http://statbel.fgov.be/Figures/download\\_fr.asp#5](http://statbel.fgov.be/Figures/download_fr.asp#5). Last update on the 23.12.2005.
- Stilmant D., Decruyenaere V. and Winance E. (2006) Comment prendre en compte le long terme dans l'orientation donnée à nos systèmes d'élevage herbagers? *Fourrages*, 185: 123-128.
- Szabó P. and Milella A. (2006) EU Agricultural Income -5.6% (real terms) in 2005. *Statistics in focus - agriculture and fisheries*, (5/2006).
- Teagasc (2004). Irish National Farm Survey Report. Published by Teagasc, Sandymount Avenue, Dublin.
- ZMP (Zentrale Markt- und Preisberichtsstelle (ZMP) (2006): ZMP – Marktbilanz Vieh und Fleisch 2006. Bonn, p. 196.



# What are the consequences of producing energy crops in the European Union for grassland renovation and new forage production systems?

Taube F.<sup>1</sup>, Hermann A.<sup>1</sup> and Pötsch E.M.<sup>2</sup>

<sup>1</sup>*University of Kiel, Grass and Forage Science/Organic Agriculture, Institute of Crop Science and Plant Breeding. 24118 Kiel, Germany*

<sup>2</sup>*Agricultural Research and Education Centre, Raumberg-Gumpenstein, 8952 Irdning, Austria*

## Abstract

The political demand of the European Union to produce energy crops is promoted by additional subsidies in several EU member states in order to enhance energy supply from crops, especially via biogas production. This will stress a competition between forage and energy production systems in grassland areas all over Europe. The authors focus on the perspectives of producing energy crops in main dairy regions of Austria and Germany. Three topics will be highlighted: (i) How does national legislation promote the demands of the EU to produce energy crops (ii) What are the perspectives of producing energy from permanent grassland, and (iii) Which promising energy production systems can be derived from grass-arable forage production systems in different dairy regions in Europe.

Keywords: Renewable energy, grassland, forage crops, biogas

## Introduction

Unmitigated climate change is likely to exceed the adaptive capacity of natural, managed and human systems. The international community therefore is faced with the great challenge to halve the greenhouse gas (GHG) emissions by the year 2050 in order to be able to master climate change consequences. In March 2007, the European Council set course for an integrated climate and energy policy. It was decided to reduce the GHG emissions by 30 percent compared to 1990 within the framework of a post 2012 climate protection agreement. Regardless of whether a new international agreement will be achieved, the EU commits right away to reducing its emissions by at least 20 per cent, and to simultaneously increase energy efficiency by 20 percent, which goes far beyond the targets laid out by the Kyoto protocol. To this end, the share of renewable energies in primary energy consumption shall be increased to 20 percent by 2020.

This brief review outlines how the EU climate protection target of increasing energy crop contribution is implemented in national legislations of Germany and Austria, and points out the potentials for producing energy crops in main dairy farming regions of the respective countries. In reference to this, the following issues are addressed (i) How does national legislation promote the demands of the EU to produce energy crops (ii) What are the perspectives of producing energy from permanent grassland, and (iii) Which promising energy production systems can be derived from grass-arable forage production systems in different dairy regions in Europe.

## The German case

In recent years, Germany has greatly expanded its role as a responsible participant in environmental policy development. In 2002, the federal government has adopted the national sustainability strategy 'Perspectives for Germany', which defines priorities for sustainable development and sets quantitative targets and measures. It comprises, for instance, a doubling of energy productivity by 2020, a reduction of GHG emissions of 21% by 2008/2010, and the increase of the share of renewable energies in electricity provision to 20% by 2020. A large boost in the development of sustainable energy provision has been brought about with the adoption of the Renewable Energy Sources Act in the year 2000, and especially by its amendment in 2004, which makes it compulsory for operators of power grids to give priority to feeding electricity from renewable energies into the grid and to pay fixed prices for this. The Renewable Energy Sources Act also promotes electricity generation from biomass, which is defined as renewable raw materials such as wood, but also plant and animal wastes. In 2005, guaranteed minimum prices for electricity produced in biogas plants ranged between 8.4 and 11.5 cent kWh<sup>-1</sup>, depending on the plant capacity (see Table 1). Additional bonuses (4-6 cent kWh<sup>-1</sup>) are provided, if electricity is exclusively produced from renewable primary products, in case of combined heat-power production (2 cent kWh<sup>-1</sup>), or if innovative technologies are applied (2 cent kWh<sup>-1</sup>). The bonuses can be used cumulatively. The feed-in tariffs are guaranteed for a period of 20 years, a degression, however, lowers the tariffs for new biogas plant installations by 1.5 percent annually.

Table 1. Feed-In tariffs for electricity produced from biomass according to the 'Renewable Energy Sources Act (1<sup>st</sup> August 2004)'. The tariff declines degressively by 1.5% annually for plants with initial operation after 01.01.2005.

	Payment (cent kWh <sup>-1</sup> )
Base payment for plants	
up to 150 kW	11.5
up to 500 kW	9.9
up to 5 KW	8.9
from 5 MW to 20 MW	8.4
for the use of matured timber (category AII/AIV)	3.9
Biomass bonus for plants	
up to 500 kW	6
from 500 kW to 5 MW	4
up to 5 MW when using wood	2.5
Power-heat coupling bonus	2
Technology bonus	2

The Renewable Energy Sources Act has led to a tenfold increase of the number of biogas plants from 1995 to 2005. In 2006, about 3,500 plants with a total electric capacity of 1000 MW<sub>el</sub> had been installed. Biogas plants are not distributed equally across the country, yet we find a concentration in regions with a high animal density, as for instance in some counties of Lower Saxony, since most biogas plants are used for co-digestion of slurry and biomass. A further increase of biogas production in such critical regions may intensify the competition for farmland and raise rental rates. A study by Bahrs and Held (2007) recently showed, that biogas plant operators can build up payment reserves for farmland to an extent that was formerly known only from specialised crop farms or animal husbandry farms. Even successful dairy farms may therefore become displaced from the regional farmland market.

As a consequence of the increase in the number of biogas plants and due to the bonus paid for the use of renewable primary products, the production of energy crops as substrate for

fermentation has gained much importance. Two criteria are decisive for choosing crop species for biomethanisation (i) the specific methane production rate (NI kg<sup>-1</sup> organic dry matter) and (ii) the biomass yield per hectare. Although grass species and cultivars may differ with respect to their chemical composition they seem to be characterised by similar specific methane production rates, ranging between 300 and 400 NI kg<sup>-1</sup> organic dry matter (Amon *et al.*, 2004; Mähnert *et al.*, 2005). Moreover, Kaiser (2006) reported methane productivity of different meadow communities to be in a similar range. While the genotype probably has a minor impact on methane production rate, the influence of the developmental stage seems more pronounced. Consistently, decreasing methane production rates were found with advancing maturity (Amon *et al.*, 2003; Amon *et al.*, 2005; Prochnow *et al.*, 2005). An increased cutting frequency therefore should also result in a higher methane productivity. The limited data base, however, does not allow ultimate conclusions, which highlights the importance of further investigation (Herrmann and Taube, 2006). Nevertheless, methane yields per hectare will hardly exceed 5000 m<sup>3</sup> ha<sup>-1</sup> a<sup>-1</sup> even for intensively managed permanent or arable grassland (Prochnow *et al.*, 2005; Kaiser, 2006).

Alternative forage crops for anaerobic digestion such as maize and whole crop small grain cereals have comparable specific methane production rates to grasses, but a much higher yield potential on many sites throughout Germany. Methane yields per hectare reported for maize range between 4000 and 10000 m<sup>3</sup> ha<sup>-1</sup> a<sup>-1</sup>, depending on hybrid and environmental conditions (Oechsner *et al.*, 2003; Schittenhelm *et al.*, 2005; Kaiser, 2006). Furthermore, substantial yield progress is predicted within the next few years. Introducing exotic germplasm from Mexico and Peru into northwest European breeding material shall raise energy maize yield potential to 30 t dry matter ha<sup>-1</sup> (Landbeck and Schmidt, 2005). The higher competitiveness of maize with respect to methane yield performance and its cost effectiveness is confirmed in a survey on the use of co-substrates. While maize is fermented in 90% of the biogas plants, grasses are less common with a share below 50% (Weiland, 2007).

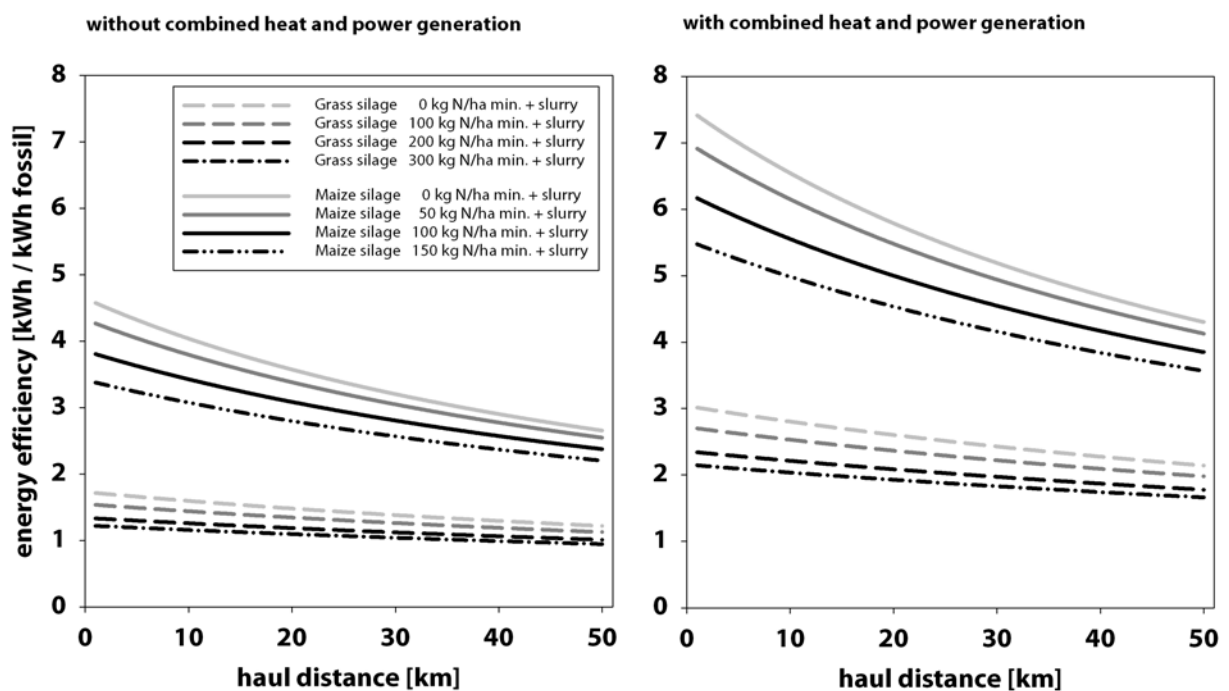

Figure 1. Energy efficiency (units energy produced per unit fossil energy input) of biogas production from grass silage and maize silage with/without power-heat coupling, depending on the distance between field and fermenter and N fertilisation (data source: N-project Karkendamm, grassland with 4 cuts versus maize monoculture).

The lower methane yields of grasses and the need of several harvests per year furthermore causes inferior energy balances, which shall be exemplified for a typical sandy region of Schleswig-Holstein, Northern Germany. Above 70% of the biogas plants in Schleswig-Holstein are located on sandy soils of low sorption capacity. Thus, biogas production is primarily associated with dairy farming, while only few arable crop farms, mainly in the marsh region, started that line of production. Due to these 'hot spots' on sandy soils, which are not suitable for wheat production, permanent grassland or arable grasses represent the sole alternatives for substrate provision. It therefore is essential to compare and appraise the impact of these two cultures with respect to climate protection. For this assessment, energy efficiency seems to be a suitable indicator. In a current study, energy balances of biogas substrate production were calculated for maize and grass grown on a typical sandy soil in Schleswig-Holstein. The impact of N fertilisation and of the availability of a power-heat coupling was analysed. In addition, we considered the distance between field and fermenter, which may span up to 50 km on many farms. Assuming current optimal degrees of efficiencies in the fermenter, the functional relationships displayed in Figure 1 were obtained. The results confirm the better performance of maize compared to permanent grassland. Consequently, the importance of permanent grassland will increase for milk production. The availability of a power-heat coupling increases energy efficiency substantially, and therefore should be a sine qua non for licensing the installation of biogas plants. Increasing distances between field and fermenter reduce energy efficiency in such a way that in case of grassland, distances around 50 km and non-available power-heat coupling the energy gain rapidly approaches zero. We thus may conclude that as long as methane injection into the gas grid is not feasible, biogas production on sandy soils in Schleswig-Holstein is energetically sound and highly profitable only if maize serves as the main co-substrate, the crop is grown in vicinity to the fermenter, and the biogas plant is equipped with a power-heat coupling.

Under the current situation, biogas farmers in intensive dairying regions will tend to increase the share of maize in substrate provision. The use of grasses for biomethanisation will mainly be restricted to arable grasses for diversifying maize rotations and to permanent grassland which is not suitable for ploughing and cannot be exploited otherwise. Biogas production from permanent or arable grassland may become competitive to maize only on marginal production sites, as for instance in growing environments with higher altitude, where maize loses its primacy. The design of forage crop rotations for biogas production is currently under investigation in several joint research projects. In this respect, yield and economy may not represent the sole criteria, but rather is a comprehensive assessment of sustainability required. The environmental effects of biogas production may vary substantially, depending on the raw materials digested, and the fuels and waste management practices replaced (Berglund, 2006). Recent findings by Scholwin *et al.* (2006) for instance indicate a bad performance of mono-fermentation systems (without slurry) regarding GHG emissions, since no mitigation of emissions from animal housing, slurry storage and spreading may be accounted for. The benefits of grassland renovation for biogas production systems are difficult to evaluate. While maintenance of grassland productivity is relevant for both, milk and bioenergy production, the benefits of forage quality improvement for biogas production are harder to quantify, since the relationship between methane productivity and digestibility seems not too close, increasing crude fibre contents were found to enhance methane output, and crude protein content obviously has a negative impact (Eder, 2006; Gröblichhoff *et al.*, 2006).

Apart from biogas, combustion might represent an alternative energetic utilisation for grassland, but combustion properties of grasses are less favourable compared to other crops or residues such as straw. Delaying the harvest to spring may reduce most elements undesirable in combustion, e.g. nitrogen, potassium, chlorine, sulphur. Furthermore, it increases the initial

ash deformation temperature. A main disadvantage of spring harvest, however, is the loss of yield during autumn and winter (Hadders and Olsson, 1997). Irrespective of technical obstacles, combustion of grass is not cost-effective.

Future perspectives include the use of grasses for BTL (biomass-to-liquid) production through a thermo chemical route. BTL-fuels may be produced from almost any type of low-moisture biomass, residue or waste. Calculation of costs anticipate straw and wood residues as main substrates for BTL production. The use of grain or whole crop cereals is assumed as economically inefficient, while BTL from perennial energy crops such as *Miscanthus* or short rotation trees, e.g. poplar and willow, is regarded cost-effective (Zeddies, 2006). For intensive grassland systems this line of production thus probably is not relevant, but it might be an alternative for landscape management grassland, since the economic input to maintain such areas could be reduced and it might become a win-win situation. Data on potential biogas production from grassland that will fall out of agricultural use is available only for few federal states in Germany, with estimates of the share of grassland for biomass production varying between 5% and 18% (Prochnow *et al.*, 2007). Although processes for BTL production are well known, production from biomass is limited to research and demonstration activities so far.

Finally, let us give some general comments on the current and future climate protection policy in Germany. At present, the end-use energy consumption in Germany amounts to 314 million tons black coal units, whereof about 0.5% are supplied by energy crops only. To achieve the ambitious climate stabilisation targets, bioenergy production from crops requires substantial expansion, which would result in a displacement of food production. In addition, further sustainability targets set by the government as for instance a 20% share of organic farming, a 10% share of the total area devoted to biotope networking, increasing biofuel usage to 5.75% of all fuel consumption by 2010, protection of soil and waterbodies by perennial cultures, and the allocation of compensation areas, together with a limited total agricultural area make assume that a successful implementation of the present energy and climate policy targets has to be questioned (Reinhard *et al.*, 2006). It therefore seems advisable to reassess the present inefficient policy of bioenergy subsidisation (indiscriminate all-round distribution). Subsidies should be allocated only to competitive lines of bioenergy production, e.g. the combustion of wood, cereals, straw, or the biogas production from residues, and the import of bioenergy from other parts of the world should be considered, where it is produced in a more efficient and sustainable way (Isermeyer and Zimmer, 2006). In view of predicted climate change effects, Germany probably will remain one of few regions with a crop production on a high level, where grassland continues to be used primarily for food production.

### **The Austrian Case**

The secure, sustainable and socially balanced supply of energy has been a focus of Austrian energy policy for decades. Therefore the permanent development of renewable energy sources is a basic strategic aspect of this policy, which also aims at the reduction of greenhouse gases. According to the Kyoto protocol Austria has committed to reduce the emissions of the six Kyoto greenhouse gases (CO<sub>2</sub>, CH<sub>4</sub>, N<sub>2</sub>O, H-CFC, CFC and SF<sub>6</sub>) by 13% by the target period 2008 to 2012 as compared to the 1990 values. In order to reach this ambitious goal an “Austrian climate strategy 2008/2012” has been initiated by the national council. This strategy mainly focuses on combining the efforts of the federal and the provincial governments to optimise the energy saving potential and to improve renewable energy sources.

At present in Austria the share of renewable energy amounts to 24% of the gross inland energy consumption and this proportion is aimed to be increased to 45% in 2020. The so far

most important source of renewable energy has been hydropower followed by firewood and some other sources, of which biogas is one of the most increasing sector (Austrian Energy Agency, 2006). The number of biogas plants in Austria has increased continuously from 20 plants in 1993 up to nearly 300 at present time with a total energy production of about 90 MW year<sup>-1</sup>. The Austrian “Ökostromgesetz” enacted in 2002 provided a strong incentive for different sources of renewable energy by means of guaranteed feed-in tariffs (scaled by the plant capacity) for a period of more than 10 years. A lot of new biogas plants were therefore planned and realised, of which most are located in regions with more favourable growing conditions for different arable crops. In the beginning stage of biogas production mainly farm manure and different organic wastes (kitchen slops, fat separates, dairy wastes, edible oil/fats, bio waste ...) were used for the fermentation process (Poetsch, 2005). In the meantime more and more biogas plants focus on the fermentation of crop biomass without any use of additional substrates.

In some regions there is therefore an increasing competition between agricultural and energetically use of land. This leads to rising rental rates for farmland and an increasing pressure for farmers with conventional production systems. This competition is tightened by the enhanced production of different bio fuels which also need plant sources like rape for bio-diesel and wheat, maize or sugar beet for bio-ethanol. An actual bio-ethanol project which will be finished in October 2007 in Lower Austria will for instance process 63,000 ha of wheat, 7,000 ha of maize and 3,000 ha of sugar beet. The total demand of farmland for an autarkic nutrition in Austria is stated with 1,6 Mio ha arable land and grassland. 275,000 ha of arable land, 180,000 ha of intensive grassland and 540,000 ha of extensive grassland are basically seen to be suitable for the production of energy crops (BMFLUW, 2006).

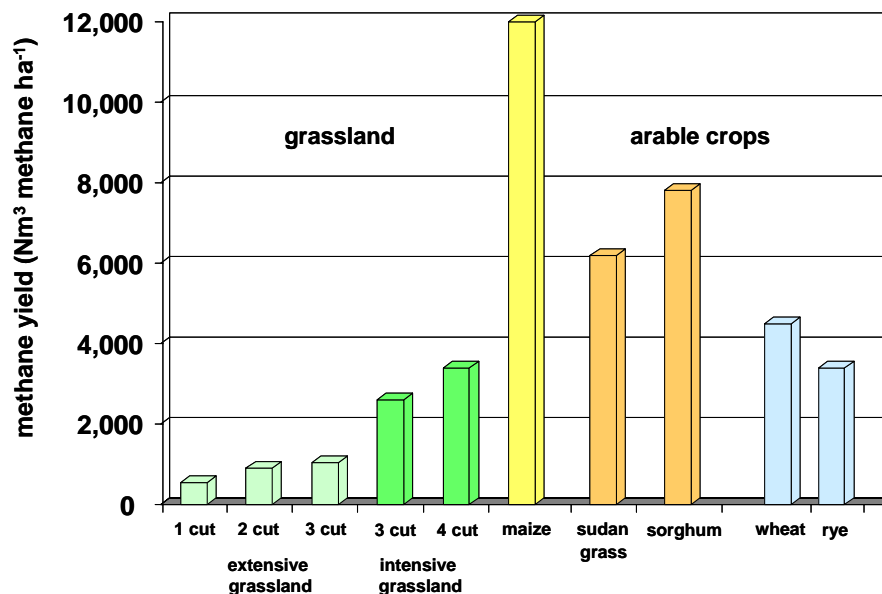

Figure 2. Methane yield production from grassland and different arable crops (Amon *et al.*, 2003).

### Consequences for grassland

Scientific findings clearly indicate, that the specific methane production rate (NI methane kg<sup>-1</sup> organic dry matter) and especially the total methane yield (Nm<sup>3</sup> methane ha<sup>-1</sup>) of grassland is significant lower than that of other crops (Figure 2). There is therefore an economic incentive to plough up grassland and to replace it with high methane yielding crops, primarily maize. Apart from negative effects on biodiversity this land use change will significantly raise the risk for ecological problems (erosion, nitrogen run off, nitrate leaching ...). Especially in

traditional grassland regions with dairy production such intensification will also negatively effect the structure of the cultural landscape. Endangered extensive grassland types, which are wide spread in disadvantaged, mountainous regions of Austria are at the same time of less interest for methane production and will not benefit from this energy production system. On the other hand it is well known, that in most of the extensive Austrian grassland regions there is an increasing amount of surplus biomass, which is not used for any agricultural intention (Buchgraber *et al.*, 2003). So therefore additional and alternative strategies have to be created to support grassland and dairy farming in such regions and to maintain the landscape and infrastructure, which is essential both for rural development and for tourism. One concept could be the support of agricultural biogas plants, which mainly use farm manure and/or grassland biomass from permanent meadows and pastures for methane production. Such biogas production systems – and there are a few existing enterprises – ideally combine agricultural production with energy production fulfilling all aspects of good agricultural practise. This also includes the environmentally friendly use of the fermentation residues, which are an important by-product of biogas production but often not adequately considered (Poetsch *et al.*, 2004). Furthermore it is evident that the energy balance (output of renewable energy versus input of fossil energy) of such biogas production systems is better than that of systems only using energy crops (Braun, 2006). The distribution of the current running biogas plants in Austria clearly shows that there is a concentration in arable regions and in favourable grassland areas, but there is a visible lack in typical grassland regions. But the current legal regulations for alternative and renewable energy production prefer high yielding crops and disadvantage grassland.

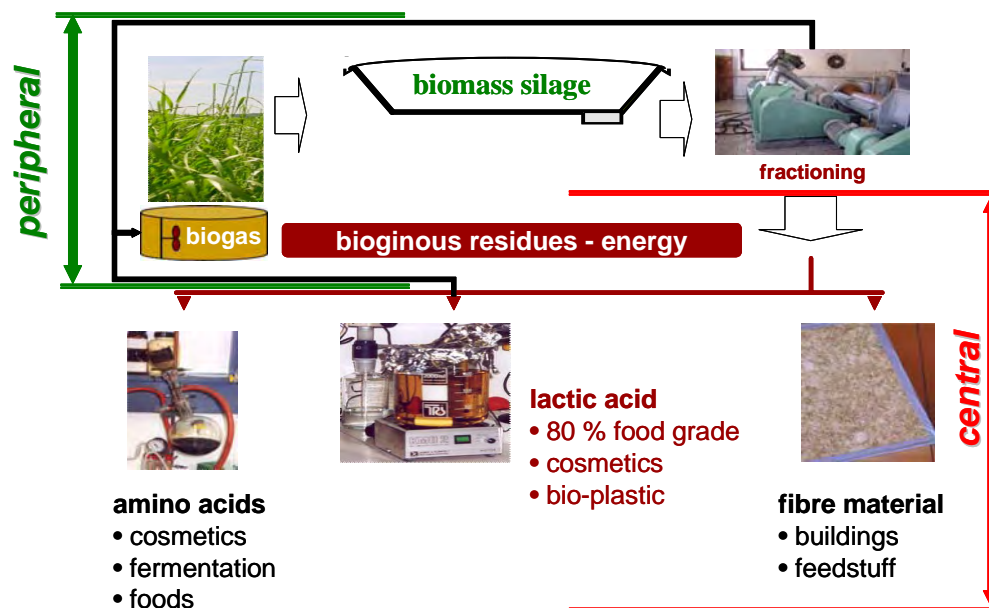

Figure 3. Schematic technical concept of the “Green bio-refinery” (Narodoslawsky, 2003)

Another promising strategy for an alternative and productive use of grassland could be the so called “Green bio-refinery”, which is a system that focuses on the efficient use of different components of grassland biomass (Narodoslawsky, 2003). The concept is subdivided into a peripheral part, which considers the small structured conditions in Austrian grassland and into a central part for the further processing steps (Figure 3). The basic raw material is biomass from different types of grassland with different levels of management intensity. This biomass is conserved as silage for a stable storage and for a permanent provision with the material. The next processing step is the local fractioning of the silage into a liquid and into a stable fraction. The stable fraction can be used for feeding, heating or fermentation in biogas plants

(peripheral) or as basic material for fibre production (central). The liquid fraction is of great attraction for its content of amino and lactic acids. Lactic acid is a key substance for polymers, solvers, or defrosting liquids for instance and there is an increasing global market. Amino acids can be used for cosmetics, fermentation or foods.

The first economical analyses of the “Green bio-refinery” system point out a high and interesting potential. Taking into account the commercial use of fibre material, amino acids, lactic acids and electricity from the residues the total revenue amounts to 1,200 – 2,900 €ha<sup>-1</sup>, depending on the market situation. In the meantime a pilot project has been installed in Upper Austria and will provide valuable data to evaluate and to develop this promising concept (BMLFUW, 2006), which could successfully contribute to maintain grassland and grassland management in Austria.

The prospective of this traditional element of agriculture not only depends on agrarian policy but also on aspects of energy and social policy. The structural changes in Austrian grassland within the last decades dramatically indicate, that special efforts have to be undertaken to equal the natural production disadvantages. This automatically means that beside a pure economical reflection, ecological aspects must be considered to ensure sustainability in agriculture and environment.

## Conclusions

The EU climate protection policy has a strong impact on crop production and land use in countries such as Germany and Austria where biomass as a source for renewable energy provision is much more subsidised than in other European countries. Due to a higher productivity of arable crops, there is a trend for converting grassland to arable land. The use of grassland for energy production is mainly restricted to obligatory grassland and to marginal areas. This may change in future if bioenergy production is certified, taking into consideration all environmental effects resulting from production and use by kind of a life-chain-analysis.

## References

- Amon T., Kryvoruchko V., Amon B., Bodiroza V., Zollitsch W. und Boxberger J. (2005) Biogaserzeugung aus Grünlandbiomasse im Alpenraum. *Landtechnik* 60, 336 – 337.
- Amon T., Kryvoruchko V., Amon B., Buga S., Amid A., Zollitsch W., Mayer K. und Pötsch E. M. (2004) Biogaserträge aus landwirtschaftlichen Gängütern. In: Bundesanstalt für Alpenländische Landwirtschaft, 10. Alpenländische Expertenforum zum Thema Biogasproduktion – Alternative Biomassenutzung und Energiegewinnung in der Landwirtschaft, 18./19. März 2004, Irnding, 21- 26, p. 1-6.
- Amon T., Kryvoruchko V., Amon B., Moitzi G., Lyson D., Hackl E., Jeremic D., Zollitsch W. und Pötsch E.M. (2003) Optimierung der Biogaserzeugung aus den Energiepflanzen Mais und Klee gras. Endbericht 2003. Available online: [http://www.nas.boku.ac.at/fileadmin/\\_/H93/H931/AmonPublikationen/Optimierung\\_der\\_Biogaserzeugung\\_aus\\_Mais\\_und\\_Klee gras.pdf](http://www.nas.boku.ac.at/fileadmin/_/H93/H931/AmonPublikationen/Optimierung_der_Biogaserzeugung_aus_Mais_und_Klee gras.pdf), verified 25.04.2007.
- Austrian Energy Agency. 2006. Renewable Energy in Austria. Available online <http://www.energyagency.at>.
- Bahrs E. and Held J.-H. 2007. Steigende Nachfrage auf den Energie- und Agrarrohstoffmärkten – Konsequenzen für die niedersächsische Landwirtschaft, die Bodenmärkte und die Agrarpolitik. Available online [http://cdl.niedersachsen.de/blob/images/C34468068\\_L20.pdf](http://cdl.niedersachsen.de/blob/images/C34468068_L20.pdf), verified 25.04.2007.
- Berglund M. (2006) Biogas production from a systems analytical perspective. PhD thesis, Lunds Univ., Sweden.
- BMLFUW (2006) Nationaler Biomasseaktionsplan für Österreich – Entwurf Endbericht. Prepared by the Austrian Energy Agency - unpublished
- Braun R. (2006) Energiebilanz von Biogasanlagen. In: *Nachwachsende Rohstoffe*, Nr. 42 – Dezember 2006, 3.
- Buchgraber K., R. Resch und Blaschka A. (2003) Entwicklung, Produktivität und Perspektiven der österreichischen Grünlandwirtschaft. In: Bericht zum 9. Alpenländisches Expertenforum „Das österreichische Berggrünland – ein aktueller Situationsbericht mit Blick in die Zukunft“, HBLFA Raumberg-Gumpenstein, 9-17.



- Eder J. (2006) Maisanbau für die Biogasanlage. GFP-Workshop 'Futterpflanzen – Perspektiven für die energetische Nutzung', Freising 9-10 März 2006, Available online [http://www.lfl.bayern.de/ipz/gruenland/18480/workshop\\_futterpflanzen\\_eder\\_lfl.pdf](http://www.lfl.bayern.de/ipz/gruenland/18480/workshop_futterpflanzen_eder_lfl.pdf), verified 25.04.2007.
- Gröblichhoff F.-F., Wulf S., Clemens J., Berendonk C. und Lütke Entrup N. (2006) Gräser in Biogasanlagen – erste Ergebnisse aus Nordrhein-Westfalen. In: 47. Fachtagung des DLG-Ausschusses 'Gräser, Klee und Zwischenfrüchte', 5-6 Dezember 2006, Fulda, 35-42. Available online <http://download.dlg.org/pdf/fachgremien/fachtagung47.pdf>, verified 25.04.2007.
- Hadders G. and Olsson R. (1997) Harvest of grass for combustion in late summer and in spring. *Biomass and Bioenergy* 12, 171-175.
- Herrmann A. and Taube F. (2006) Die energetische Nutzung von Mais in Biogasanlagen - Hinkt die Forschung der Praxis hinterher? *Ber. Landwirt.* 84, 165-197.
- Isermeyer F. und Zimmer Y. (2006) Thesen zur Bioenergie-Politik in Deutschland. Arbeitsbereiche des Bereichs Agrarökonomie 02/06, FAL Braunschweig. Available online [http://www.fal.de/nr\\_791716/SharedDocs/11\\_MA/DE/Publikationen/Bereich/download\\_ab\\_02\\_2006\\_de.tEMPLATEID=raw,property=publicationFile.pdf/download\\_ab\\_02\\_2006\\_de.pdf](http://www.fal.de/nr_791716/SharedDocs/11_MA/DE/Publikationen/Bereich/download_ab_02_2006_de.tEMPLATEID=raw,property=publicationFile.pdf/download_ab_02_2006_de.pdf), verified 25.04.2007.
- Kaiser F. 2006. Methanertragspotenziale verschiedener nachwachsender Rohstoffe. Workshop „Futterpflanzen – Perspektiven für eine energetische Nutzung“, Bayerische Landesanstalt für Landwirtschaft, Freising, 09./10.03.2006. Available online [http://www.lfl.bayern.de/ipz/gruenland/18480/workshop\\_futterpflanzen\\_kaiser\\_lfl.pdf](http://www.lfl.bayern.de/ipz/gruenland/18480/workshop_futterpflanzen_kaiser_lfl.pdf), verified 25.04.2007.
- Kaltschmitt M. 2007. Energie aus Biomasse. ‚Zukunftskonferenz Maschinenbau‘, 14./15. März 2007, Leipzig, Available online [http://www.zukunft-maschinenbau.de/set/1119/6\\_Vortrag\\_Kaltschmitt.pdf](http://www.zukunft-maschinenbau.de/set/1119/6_Vortrag_Kaltschmitt.pdf), verified 25.04.2007.
- Landbeck M. und Schmidt W. (2005) Energiemais – Ziele, Strategien und erste Züchtungserfolge. In: International Energy Farming Congress, 2. – 4. März 2005, Papeburg.
- Mähnert P., Heiermann M. and Linke B. (2005) Batch- and semi-continuous biogas production from different grass species". *Agricultural Engineering International: the CIGR Ejournal*. Manuscript EE 05 010. Vol. VII. December, 2005.
- Narodoslawsky M. (2003) Alternative Grünlandnutzung – stoffliche Verwertung grüner Biomasse in der „Grünen Bioraffinerie“. In: Bericht zum 9. Alpenländisches Expertenforum „Das österreichische Berggrünland – ein aktueller Situationsbericht mit Blick in die Zukunft“, HBLFA Raumberg-Gumpenstein, 77-79.
- Oechsner H., Lemmer A. und Neuberger C. (2003) Feldfrüchte als Gärsubstrat in Biogasanlagen. *Landtechnik* 3/2003, 146-147.
- Poetsch E.M. (2005) Final report of the project "Nutrient content of fermentation residues from agricultural biogas systems and their utilization on permanent grassland", HBLFA Raumberg-Gumpenstein, 33 pp.
- Poetsch E.M., E. Pfundtner and Much P. (2004) Nutrient content and hygienic properties of fermentation residues from agricultural biogas plants. EGF-Meeting "Land use systems in grassland dominated regions", *Grassland Science in Europe*, Vol.9, 1055-1057.
- Prochnow A., Heiermann M., Drenckhan A. and Schelle H. (2005) Seasonal pattern of biomethanisation of grass from landscape maintenance. *Agricultural Engineering International: the CIGR Ejournal*. Manuscript EE 05 011. Vol. VII. December, 2005, available online <http://cigr-ejournal.tamu.edu/volume7.html>, verified 25.04.2007.
- Reinhard G., Scheurlen K. und Benning R. (2006) Zuviel des Guten? Energiegewinnung aus Biomasse im Kontext der Nachhaltigkeitsziele in Deutschland. *Der kritische Agrarbericht* 2006, 183-188.
- Schittenhelm S., Weiland P. und Sourell H. (2005) Einfluss der Wasserversorgung auf den Biomasse- und Biogasertrag von Energiemais. *Mitteilungen der Gesellschaft für Pflanzenbauwissenschaften* 17, 114-115.
- Scholwin F., Michel J., Schröder G. und Kalies M. (2006) Ökologische Analyse einer Biogasnutzung aus nachwachsenden Rohstoffen. Institut für Energetik und Umwelt. Available online [http://www.fnr.de/pdf/literatur/pdf\\_273ie%20\(2007\)%20endbericht\\_oekobilanzen\\_final.pdf](http://www.fnr.de/pdf/literatur/pdf_273ie%20(2007)%20endbericht_oekobilanzen_final.pdf), verified 25.04.2007.
- Weiland P. (2007) Biogas – Stand und Perspektiven der Erzeugung und Nutzung in Deutschland. *Agrarspectrum* 40, 111-122.
- Zeddies J. (2006) Rohstoffverfügbarkeit für die Produktion von Biokraftstoffen in Deutschland und in der EU-25. Available online [http://www.ufop.de/downloads/Flaechenpotenzial\\_studie.pdf](http://www.ufop.de/downloads/Flaechenpotenzial_studie.pdf), verified 25.04.2007.

# Legislation with respect to grassland renovation and grass-arable rotations in England

Jewkes E.C.<sup>1</sup>, Hatch D<sup>1</sup>. and Hopkins A.<sup>2</sup>

<sup>1</sup>*IGER, North Wyke, Okehampton, Devon, EX20 2SB, UK*

<sup>2</sup>*Centre for Rural Policy Research, University of Exeter, Exeter, UK*

## Abstract

A number of legislative and non-legislative frameworks exist in England that may impact upon the potential for grassland renovation and cultivation of swards. The frameworks are principally concerned with water quality or biodiversity and vary in the magnitude of their effect on farmers' management decisions. The regulatory instruments include Nitrate Vulnerable Zones (NVZs), SSSIs and other restrictions under the Wildlife and Countryside Act of 1981, Environmental Impact Assessment (EIA) rules regarding management of swards >5 years of age and cross-compliance and stewardship schemes, whereby entry is voluntary, but management conditions become legally binding once entered into. The primary non-legislative instrument is the "supported initiative" for Catchment Sensitive Farming, which aims to reducing phosphorus, faecal indicator organisms, sediment and nitrates loads in England to meet WFD requirements through developing measures for inclusion into the WFD Programme. Whilst all potentially affect decisions regarding renovation or cultivation of grassland swards, most can be incorporated into a careful management regime whilst allowing a level of production intensity likely to be feasible for the farmer; those that are more stringent in their requirements attract compensatory payments.

Keywords: legislation, grassland cultivation, lay-arable rotations

## Introduction

This paper describes the main legislative and non-legislative ("supported initiatives") frameworks for environmental protection that may have impacts upon the potential for grassland renovation and cultivation of grass swards on farms in England. These frameworks principally concern water quality and biodiversity issues and have a varying degree of effect on the management choices on grassland farms.

As an initial response to the Nitrates Directive (Council Directive, 1991), in 1996, 8% of land in England was designated as a Nitrate Vulnerable Zone (NVZ); in 2002 this was increased to 55%. The guidelines require that only the amount of N required by a crop should be applied, taking particular account of situations of increased N supply, such as regular applications of organic manures or from recently ploughed intensively managed grass. The Action Programme measures apply only in the NVZs to promote best practice in the use and storage of fertiliser and manure and build on existing guidelines set out in the *Code for Good Agricultural Practice for the Protection of Water*. Farmers outside of the NVZs are also encouraged to follow these voluntary Codes of Good Practice, for the protection of the environment. These measures are intended to prevent nitrate levels rising to the point where regulation becomes necessary. They also help to reduce other pollution, including phosphorus losses, microbiological contamination of bathing waters and pesticide losses. Although the Nitrates Directive provides for some discretion over the content of Action Programmes, there are certain measures which must be included. There are four key aspects to the measures:

1. Limit inorganic nitrogen fertiliser application to crop requirements, after taking into account nitrogen residues in the soil and other sources.
2. Total organic manure loadings (including grazing depositions) must be limited to 210 kg N ha<sup>-1</sup> of total nitrogen each year, averaged over the area of the farm not in grass (reducing to 170 kg after four years), and 250 kg N ha<sup>-1</sup> of total nitrogen each year averaged over the area of grass on the farm (the application limit to individual fields, regardless of land use, is 250 kg ha<sup>-1</sup>).
3. On sandy or shallow soils do not apply slurry, poultry manures or liquid digested sludge between 1 September and 1 November (grassland or autumn sown crop) or between 1 August and 1 November (fields not in grass without autumn sown crop). The storage capacity available for those animal manures which cannot be applied during the autumn closed period must be sufficient to cover these periods unless other environmentally acceptable means of disposal are available.
4. Keep adequate farm records, including cropping, livestock numbers and the use of organic manures and nitrogen fertilisers.

All farmers within the NVZs have been required to implement these measures since 19 December 2002. Farmers located within the existing NVZs designated in 1996 have been required to adhere to a lower limit of 170 kg ha<sup>-1</sup> total N per year for manure loading on arable land since 19 December 2002. Farmers located in the new NVZs will also be required to adhere to this lower limit from 19 December 2006. Applications to individual fields must not exceed 250 kg total N per ha, regardless of land use, in accordance with the advice in the Codes of Good Agricultural Practice. Adherence to the NVZ rules is now a statutory management requirement under the Single Farm Payment scheme (cross-compliance), implemented in spring 2005, meaning that infringements may result in loss of subsidy revenue to the farmer.

The Water Framework Directive (WFD) came into force on 22 December 2000 (CEC, 2000). The Directive sets out a timetable for both initial transposition into laws of Member States and thereafter for the implementation of requirements. To help meet our obligations under the WFD, the Catchment Sensitive Farming (CSF) initiative is intended to reduce agricultural sources of diffuse pollution within river catchments and has implications for cultivating land that could result in the release of nutrients and soil particles to water courses. The Catchment Sensitive Farming Programme is a "supported initiative" aimed at reducing phosphorus, faecal indicator organisms, sediment and nitrates loads in England to meet WFD requirements through developing measures for inclusion into the WFD Programme. Although currently non-legislative in itself, the programme will help agriculture to play its role in ensuring that water in England is as clean and healthy as practical.

A 'Common Implementation Strategy' (CIS) has also been established by member states and the European Commission to help promote the implementation of the WFD across the EU and facilitate the exchange of best practice and experiences. Defra, devolved administrations, and the UK Environment Agencies have participated in the development of the CIS and guidance on estuarial and coastal waters, on heavily modified water bodies and the impact of human activity on surface and groundwater. A key element of the CIS is the integrated testing of guidance in pilot river basins, undertaken through an EU Pilot River Basin network, involving fifteen river basin projects. The UK participation in this network is through the *Ribble Pilot River Basin* project, located in the North West River Basin District, which was formally launched on 10 June 2003.

For the more general protection of grassland, two levels of a new scheme of Environmental Stewardship came into being in 2005, effectively extending the agri-environment agreement opportunities to all farms in England (with slightly different arrangements for other regions of the UK). Entry-level stewardship (ELS) is available to all farmers, whereby a per hectare

payment is received for agreeing to undertake self-determined specified measures to protect biodiversity, the environment or historic features. The measures are calculated on a points basis, and actions totalling 30 points per ha are required to obtain payment. Higher Level stewardship (HLS) is more stringent and discretionary – it is not open to all – and membership of ELS or similar is normally required before it is granted. Entering into agreements such as maintaining grassland at a low input level may appear beneficial until reseeded is contemplated or until additional nutrition, that is not permitted, may be required. Also, whilst there are rotational options, which make some allowance for ley-arable rotations, most of these do not include the cultivation of maize, which may be problematic for intensive grassland farmers, particularly in the dairy sector. Options for cultivated land that have equivalent categories under grassland – for instance field margin buffer strips – may be acceptable in a ley-arable rotation so long as the land area can be qualified as cultivated, or an application for a change to the agreement is applied for. Careful consideration of current and potential future land requirements is needed before entering into stewardship agreements. Whilst entry to the schemes is voluntary, once entered into they effectively become legal agreements with the relevant payment body and may reduce the flexibility for future cultivation possibilities. In addition, cross compliance rules require a proportion of land that was registered as arable at the cut-off date to be placed in set-aside each year. This may also impact upon cultivation choices, as it could effectively increase stocking pressure on, for example, an intensive dairy farm, thus reducing the area that might be considered for cropping.

For very special areas of grassland, there are existing regulations preventing cultivation in Sites of Special Scientific Interest (SSSIs), protected under the Wildlife and Countryside Act 1981 (JNCC, 2002), or the Conservation (Natural Habitats etc.) Regulations 1994, which would also include National Parks. In the 'Habitat Scheme, Water Fringe Areas', farmers were banned from ploughing, levelling, or reseeded grass. Under the 1981 Act, any grassland or arable land crossed by public rights of way (footpaths) must, within 14 days of being cultivated, have the area over which the path extends reinstated, even if the rest of the field is to remain in an uncultivated state for a longer period. More recent legislation has come into force in February 2002 (revised in 2007), in the form of Environmental Impact Assessments (EIA), to consider the potential environmental effects of projects which involve change of land use (Natural England, 2007). Grassland swards which are more than 5 years old are regarded as permanent pasture for the purposes of cross-compliance and if it is planned to plough or intensify production, farmers (since 2002) need to carry out an EIA to confirm that the sward includes >30% of productive (sown) species of grasses / legumes. Importantly, this legislation was introduced at short notice during the winter period, thereby preventing any pre-emptive agricultural improvement before the rules took effect. The legislation has been extended by bringing in EIA procedures for projects for the *use of uncultivated land or semi-natural areas for intensive agricultural purposes*. These regulations now implement specific European Community requirements. Land would be considered to be uncultivated if it had less than 25-30% of ryegrass (*Lolium* species) and/or white clover (*Trifolium repens*), or other sown grass species indicative of cultivation, where cultivation includes ploughing, rotavating, harrowing, tining, discing and reseeded.

The legislation possibilities outlined above may potentially have a large impact on grassland management, whether for renovation or ley-arable rotations. This can range from a requirement to consider nutrient loadings or potential runoff/leaching losses, as contained within the Nitrates Directive or WFD (as CSF), or whether under prescriptive, but voluntary schemes, such as ELS or HLS. The NVZ nutrient loadings may be particularly important in a

ley-arable situation if the arable area does not remain constant each year, as the smaller arable limit may result in a lower theoretical stock-carrying capacity of the farm, in order to comply. However, careful management should preclude most problems that might occur as a result of the legislative process. Examples might include choosing rotational options for ELS points or considering carefully any fields that may be entered into low input designations, whilst farm manure nutrient loadings should be assessed on the basis of the likely grass-arable balance of land holding. Many of the CSF requirements to reduce diffuse pollution to water are contained within the recommended codes of good agricultural practice and thus should be followed routinely, particularly if the land is registered as cross-compliant. Whilst farms incorporated into a SSSI receive monetary compensation for the limits on their production intensity, the restrictions of the Wildlife and Countryside Act were viewed as excessive in some quarters and encountered some opposition at their inception. The more recent rules however, requiring an EIA prior to ploughing grassland >5years old, may be as, if not more, problematic, as they affect all farms and potentially restrict the options a farmer has for intensification of or making alterations to the existing management. In the current economic situation in agriculture, this may be viewed as unhelpful for farmers trying to minimise costs per unit output. It may also contradict other "good practice" suggestions, such as cultivating and feeding maize to dairy cows to reduce dietary N intakes relative to a grass diet.

## Conclusions

A number of legislative and non-legislative frameworks exist which may impact upon the reseeded cultivation policies that a farm can implement. Most can be readily incorporated into a careful management strategy and achieve environmental benefit whilst maintaining levels of productivity that are acceptable in the current challenging economic climate. The more stringent regulations make this more difficult, but the compensatory payments and carefully thought out management can provide some redress for the difficulties.

## References

- Council Directive 91/676/EEC of 12 December (1991) concerning the protection of waters against pollution caused by nitrates from agricultural sources. Official Journal of the European Communities L327, 1-72, 2000.
- Council of the European Communities (CEC) (2000) Directive 2000/60/EC of the European Parliament and of the Council of 23 October 2000, establishing a framework for Community action in the field of water policy. Official Journal of the European Communities L327, 1-72, 2000.
- JNCC (2002) Wildlife and Countryside Act: <http://www.jncc.gov.uk/page-3614>
- Natural England (2007) Guidance on EIA (Agriculture)(England)(No 2) Regulations 2006 October 2006, revised February 2007: <http://www.defra.gov.uk/farm/environment/land-use/eia/pdf/guidance-regs06-rev070213.pdf>

# Functions of permanent grasslands in forage system of beef cattle farms in Burgundy. Impacts on technical implementations

Granger S.<sup>1</sup>, Soulard C.<sup>2</sup>, Ingrand S.<sup>3</sup> and Compagnone C.<sup>1</sup>

<sup>1</sup> ENESAD, INRA, 26 bd Dr Petitjean, BP 87999, F-21079 Dijon cedex, France

<sup>2</sup> INRA-SAD, 2 place Viala, F-34060 Montpellier cedex1, France

<sup>3</sup> INRA-SAD, UMR1273, EquipeTSE, F-63122 Saint-Genes-Champanelle, France

## Abstract

In Burgundy, one third of the farms are specialised in beef cattle systems in which permanent grasslands are the main feed resource. Forage production to meet animal requirements remains one of the main concerns of beef cattle farmers. Technical references on fertilisation, pasture management or sowing more productive species are available. Despite of this favourable context, farmers buy hay and straw, or use concentrates to compensate for the lack of forage resources.

In order to identify the factors of dissemination and adoption of technical innovations in the forage domain, we characterized grasslands management in sixty-three farms chosen according to: (i) farm size and stocking rate; (ii) range of fodder crops. We analysed: (i) balance between grazing and cutting; (ii) proportion of permanent grasslands in the forage system, especially for hay or silage. The diversity of sown species and duration of temporary grasslands, the use of wrapping, as an innovative harvesting technique, are discussed.

Keywords: permanent grassland, temporary grassland, management, beef cattle farms

## Introduction

In Burgundy, one third of the farms are specialised in beef cattle production with permanent grasslands as the main feed resource. Forage production to meet animal requirements remains one of the main concerns of beef cattle. Indeed, lack of forage has to be compensated for by buying hay and straw, or using concentrates. Previous studies (Gateau *et al.*; 2006) conducted in the area of the Saône et Loire, Burgundy, showed that the economic efficiency of beef cattle farms strongly depends on the contribution of grasslands to the total diet. Economic efficiency was higher on farms where: (i) proportion of cut grasslands was the highest; (ii) grasslands received more fertilisers; (iii) animals received less concentrates.

Whereas technical studies on fertilisation or rotational grazing management received much attention, permanent grasslands were managed with a low level of intensification. They were mainly grazed: 61% and 56% of the area in Burgundy and France, with lower level of fertilisation in Burgundy: 38% were fertilised with an average of 45 kg/ha of nitrogen. Over all France, 63% of the acreage of permanent grasslands were fertilised with a mean rate of 64 kg N/ha (Agreste, 2000).

In order to analyse the factors of dissemination and adoption of technical innovations in forage systems (*i.e.* the way the farmers acquired and used information and new techniques), we studied the function of permanent grasslands in beef cattle farms assuming that the way permanent grasslands are managed by farmers depended on the assessment of their function. We hypothesized that the function of permanent grasslands was positively correlated with proportion of permanent grasslands (*vs* temporary grasslands) on the farm and intensity of their management (fertilization, use for grazing or harvesting, harvesting method). We

focused on forage wrapping as a technical innovation analysing reasons for its adoption by farmers and relationships with the value they assigned to permanent grasslands.

## Materials and methods

We described forage management by surveys performed in 63 farms among 4894 in the study area, chosen in order to take into account the diversity found in beef cattle farms in Burgundy. Each farm was characterized by: (i) farm size and stocking rate; (ii) range of fodder crops.

We devised the questionnaire to evaluate in detail: (i) balance between grazing and cutting; (ii) proportion of permanent grasslands in the forage system, especially their use for hay or silage. To collect data on explicative factors, the farmers were also interviewed about: (i) farm structure (total area and labour force, field pattern and livestock housing); (ii) grasslands management (grazing and harvesting practices, fertilisation); (iii) livestock management (calving dates, range of animals sold, feeding practices); (iv) social frameworks of farmers (technical information and interactions with the extension services).

## Results and discussion

### *Classification of forage management*

The main characteristics of forage management differing between the farms were: (i) the farmer's priority and balance between grazing and cutting; (ii) the function of permanent grasslands regarding their use and management. We used these two criteria as typological keys to sort the farms using a multicriteria analysis. We obtained five groups (Table 1) corresponding to different forage management systems.

Table 1: Main characteristics of the five forage management systems differing by: (i) priority between grazing and cutting; (ii) function of permanent grasslands in the farm (mean values).

(number of farms)	Group 1 (16)	Group 2 (16)	Group 5 (5)	Group 4 (15)	Group 3 (11)
Priority of the forage system	Cutting			Grazing	
Function of permanent grasslands in the farm *	+	-	--	++	+++
Total area (ha)	89	182	265	150	98
Livestock unit/ha	1.06	1.20	1.72	1.25	1.49
Suckling cow/labour unit	40-50	60-90	60-90	50-70	35-50
Beef production	male	lean	lean or fat	Various, breeds	lean
Temporary grassland type	% forage area	lean	fat		fat
Harvested area (first cut) (% grassland area)	20%	12%	40%	18%	0%
	TG1	TG2	TG1 and TG2	TG1	-
Forage stores	36%	42%	35%	36%	32%
Topping for hay	Hay (PG)	Wrapping (TG2) Hay (PG)	Silage (TG2) Hay (TG1)	Silage or wrapping, hay (TG1, PG)	Hay (PG)
Grasslands fertilized	none	Various **	Whole area	Various**	Whole area
	none	Harvested areas	Harvested areas	Grazed and harvested areas	Harvested areas
TG1	more than 3 species (including rye-grass, cocksfoot, white clover), duration = more than 5 years, used for grazing or cutting (one cut)				
TG2	one or two species, duration = 2 to 3 years, only used for cutting (2 to 3 cuts)				
PG	permanent grassland				
*	main interest (+++) to low interest (- -) in permanent grasslands				
**	on some farms only and/or never the whole hay area				

Three groups (1, 2 and 5) prioritised forage conservation: at the first growth cycle, the proportion of harvested grassland ranged from 35% (with several cuts) to 42% (with only one cut). The harvested grasslands were those considered by farmers as the most productive. The other two groups (3 and 4) prioritised grazing on the most fertile paddocks. These paddocks were fertilised, grazed by suckling cows, often using a rotational grazing system.

The management of permanent grasslands showed a contrast between groups 2 and 5 on one hand and the other three on the other hand.

Farmers of groups 2 and 5 harvested temporary grassland sown with one or two species (Italian rye-grass, cocksfoot, lucerne or red clover) with short crop duration (TG2). These grasslands were fertilised, cut 2 or 3 times a year for silage or wrapping. Farms of group 5 also used another type of temporary grasslands (TG1) sown with complex mixtures for a long life duration (more than 5 years). These grasslands were used for hay production in the first cycle and then for grazing. When needed, *i.e.* because of a low proportion of temporary grassland in the farm, hay was produced on permanent grasslands. Farmers of group 2 also harvested sown set-aside.

In groups 1, 3 and 4, both temporary and permanent grasslands were either grazed or harvested. The establishment of temporary grasslands, belonging to the type TG1, was justified by the need of pasture renovation (group 1, situation with low potential for forage production, animals sold prior to fattening) or of production early in spring (group 4). Farmers of group 3 considered permanent grasslands to be of good quality.

*Relationships between permanent grasslands and innovative behaviour of farmers: the example of wrapping.*

Wrapping appears in our surveys as a good example of technical innovation in beef cattle farms. This technique is not really new; it was known and offered to farmers from the 1980's but its use on beef cattle farms in Burgundy seems to be more recent (Liénard *et al.*, 1998). This last point was confirmed in our surveys. Among the 63 interviewed farmers, 31 used wrapping. Date of introduction and reasons for choosing this technique depended on the farmers group they belonged to (Table 2).

Table 2: Use of wrapping (decreasing range) in the 63 farms according to the five groups described in Table 1

Group	3	4	2	5	1
Farms using wrapping	64%	60%	63%	60%	12%
Date of introduction	In the 1990's		Since 2000	In progress or foreseen	Not yet with a few exceptions
Reasons	Harvesting earlier 2 <sup>nd</sup> cut	Forage quality Flexibility	Use of sown set-aside or forage legumes	Replacement of grass silage	No interest

The example of wrapping shows how the adoption of a technical innovation is relevant to strategies and practices. The farmers who first took the opportunity of wrapping prioritised grazing (groups 3 and 4). They considered this harvest technique as a way to optimise grazing. Indeed, an earlier harvest favoured a better growth in the second growth cycle, a high yield in the second cut or gave more flexibility during grazing. This harvest method was equally used on permanent and temporary grasslands. On the opposite, farmers of group 5 organised with collective silage harvests were the last to be interested in wrapping. Wrapping replaced silage in farms where the labour resource or mutual aid decreased. In all cases, silage or wrapping was used on highly productive grasslands, *i.e.* on sown grasslands (TG2). With wrapping technique, farmers of group 2 took the opportunity to use forage legumes and sown set-aside as fodder crops. They did not use wrapping on permanent grasslands.



In group 1, the livestock farming system (lean beef cattle, late calving dates) did not require high quality forage. Moreover, the economic situation did not permit a lot of investment.

## Conclusion

The statistical trend of using permanent grasslands for grazing holds true in the set of the interviewed farms, whatever the forage management. Management intensity on grazed areas, such as fertilisation and grazing method of suckling cows (set stocking or rotational), depended on the overall forage management. Management of grazed paddocks was of low intensity in groups 1, 2 and 5 as priority was given to harvesting. Farmers of groups 1 and 4 worried about the quality of grazed pastures and were used to renovating grasslands with a mixture well suited to grazing. To their minds, sown grasslands (TG1) behave similarly to permanent grasslands.

For making stocks, permanent grasslands were not a priority in the forage management observed in groups 2 and 5 with no technical investments on harvesting method. As a consequence, hay was produced on permanent grasslands while silage or wrapping was performed on temporary grasslands. Permanent grasslands received less or even no fertilisation compared to the other harvested areas.

The classification of forage management is a way for rural extension people to promote extension operations and advices the most adapted to farmers. Farms of group 1 were characterized by a low production potential (structural, soil and climate). Farmers were concerned with effects of production factors to improve grassland production and possibility for low-intensity animal production. In group 2, permanent grasslands which were not easily tillable contributed a high proportion to forage area. Temporary grasslands were located in the tilled part of the farms. Farmers were interested in diversity and choice of species for the cultivation of complementary forage, such as set-aside or inter-crops. Farmers of group 5 wanted to increase the productivity of labour and chose to simplify crop and animal management through choice of highly productive forages, set stocking grazing, grouping of calvings. Farmers of groups 3 and 4 looked after decision making tools for grazing, advices on use of manure on permanent grasslands and composting of animal manure.

More specifically, on permanent grasslands, farmers were concerned with their degradation. They considered phosphorus and potassium fertilisation as a positive factor on forage quality and on animals growth and reproduction. On the opposite, nitrogen fertilisation was seen as a factor of degradation. The way of renovating permanent grasslands, historically made by ploughing and resowing, has to be changed taking into account constraints of the new CAP regulation for permanent areas. Overseeding and direct seeding of grassland as well as the choice of forage species and varieties adapted to drought were discussed. Beef-farmers were interested in getting more information on these different topics and their request could promote new dialogues.

## References

- Agreste (2000) *Chiffres et Données Agriculture. Les prairies en 1998*, SCEES, n°128, 73p.
- Gateau C., Novak S., Kockmann F., Ruget F. and Granger S. (2006) Use of the ISOP system, based on the STICS model, for the assessment of forage production. Adaptation to grassland and spatialized application. *Fourrages*, 186, 241-256.
- Liénard G., Bébin D., Lherm M. and Veysset P. (1998) Modes de récolte des fourrages et systèmes d'élevage. L'exemple des exploitations de la zone charolaise. *INRA Prod. Anim.*, 11, 387-395.

# **A decisional model for predicting the development of Alpine pastures at mid and long-term scale**

Venerus S.<sup>1</sup>, Dovier S.<sup>1</sup>, Pasut D.<sup>2</sup>, Bottecchia C.<sup>2</sup>, Bovolenta S.<sup>3</sup> and Parente G.<sup>1</sup>

<sup>1</sup>*Agenzia Regionale per lo sviluppo rurale (ERSA), viale Martelli 51, 33170 Pordenone, Italy.*

<sup>2</sup>*Servizio Agricoltura Aziende Sperimentali e Dimostrative (SAASD), Province of Pordenone, viale Martelli 51, 33170 Pordenone, Italy*

<sup>3</sup>*Department of Animal Science (DIAN), University of Udine, via S. Mauro 2, 33010 Pagnacco (UD), Italy*

## **Abstract**

The highland pastures in the Friuli Venezia Giulia region, N-E Italy (named “malghe”) are abandoned or under utilised systems in the last years. Nevertheless, their importance, ecological and economical reasons, makes actual to find viable solutions for their restoration, which implies to integrate all the functional aspects, in order to obtain a sustainable recovery of these systems. A model has been developed and applied as a decisional tool for supporting public owners and pasture managers to choose proper alternatives of management. The model consists of a background data collection for describing the areas under analysis, the data arrangement in a numerical matrix, application of multivariate cluster analysis for classifying the highland pastures into homogenous groups, and finally the application of multi-criteria techniques for their suitability analysis to different management. The study area was located in the Venetian Prealps in the Province of Pordenone, involving 13 farms managing 25 “malghe” over about 900 ha of pastures. The results obtained showed the reliability of the model, which could be applied in other marginal areas where the alpine pastures still represent a viable opportunity of territorial development.

Keywords: model, highland pastures, sustainable development

## **Introduction**

It is important to find proper solutions for recovering and relaunching traditional activities of the Friuli Venezia Giulia mountains (N-E Italy), as the highland pastures (named “malghe”), for several reasons, among which: i) to oppose the progressive territorial abandonment of the highland pastures, which decreased from more than 400 units at the beginning of the 20<sup>th</sup> century, to about 90 nowadays in the Friuli-Venezia Giulia region; ii) to contribute to the social-economical development of the alpine areas, where the pasture activities can still represent a remarkable income source, if highland pasture farms are carried out according to an integrated, multi-functional approach; iii) to restore and preserve typical mountain landscapes, thus favouring environmental-friendly tourism; iv) to conserve remarkable sources of biodiversity; and v) to maintain the local cultural heritage. These aims could be reached through favouring an entrepreneurial approach to a traditional activity, providing pasture managers and territorial decision makers with guidelines and analytical decision tools. From this perspective, it is necessary to know the territory in details to formulate reliable development plans, as result of applying models of analysis, management and development of the highland pastures (Bovolenta *et al.*, 2006). This paper presents the results of the model application in a case study of the Friuli Venezia Giulia highland pastures, where animals are moved during summer from the plain to the mountain farms, consisting of pastures and buildings used for animal shelter and cheese production.

## Materials and methods

*Study area* - The study area is located in the Venetian Prealps (Province of Pordenone, N-E Italy). The average annual temperature is 11°-12°C and the rainfall is about 1700-1900 mm/year, homogeneously distributed during the growing season. The water availability is limited, notwithstanding the high rainfall, due to the karst-type limestone soil,. The pasture vegetation belongs to pure communities as *Festuco-Brometea* and *Seslerietea albicantis*, while a small part located in flat areas belongs to *Molinio-Arrhenatheretea* (Pasut *et al.*, 2006).

In this area 13 farmers use 25 *malghe*, with about 900 ha of pastures. All the *malghe* belong to the municipalities (owners). We defined as a “Management Unit” (MU) pastures and buildings of different *malghe* managed by the same farm (managers). Grazing animals are mainly cattle, sheep and goats.

*Descriptive analysis* - Several territorial descriptors were collected from literature and field surveys in a database, related to geography, pasture characteristics, animals, products, buildings, infrastructures and economy. 73 variables were initially analysed and reduced to 36, according to a step-by-step exclusion criteria process, based on their descriptive power, redundancy and attribution of objective value. The chosen variables were attributed to three categories, based on the influence of manager (M), owner (O) or independent (I) in the values definition (Table 1).

Table 1. The 36 chosen variables, classified into three categories: M = manager, O = owner, I = independent

N.	Category	Variable	N.	Category	Variable
1	I	Slope > 40%	19	M	Milking animals
2	I	Permanent fences	20	M	Animal species
3	M	Electric fences	21	M	Shepherd presence
4	O	Density of water points	22	M	Feed supplement
5	I	Distance from lowland	23	M	Cattle production
6	M	Grazed area	24	M	Sheep production
7	I	Shrub distribution	25	O	Tourist lodging
8	I	Weeds	26	M	Cold meals providing
9	I	Pasture distribution	27	O	Hot meals providing
10	M	Scrub clearing frequency	28	O	Facilities for disabled person
11	M	Scrub clearing type	29	O	Electric energy availability
12	M	Manure type	30	O	Drinking water availability
13	M	Pasture management	31	O	Milking system
14	M	Grazing season (period)	32	O	Cheese making equipment
15	M	Number of workers	33	I	Karst landscape
16	M	Man-days	34	I	Panoramic views
17	M	Stocking rate	35	I	Hiking paths
18	O	Water availability	36	I	Isolated <i>malga</i>

The final data set was arranged in a matrix of 36 rows (variables) x 13 columns (MUs). Each variable was re-scaled into ordinal or binary classes (presence/absence). The matrix (Table 1) was analysed by cluster analysis applying correlation coefficient similarity between cases and minimum variance algorithm of agglomeration, with the aim of detecting homogeneous groups of MUs.

*Suitability Analysis* - The data matrix was also used to analyse the suitability of each MU with regard to different objectives (scenarios). Three different scenarios for optimising the sustainable profit of the MUs were chosen, e.g. a) improving pastures quality (“Pasture”), b) maximising cheese and meat production (“Product”), and c) developing tourist infrastructures (“Tourism”). The classic technique of multi-criteria analysis was applied (Malczewski 1999,

Janssen and van Herwijnen 1994), consisting of the following steps: 1) all variables were normalised on a scale ranging from 0 to 1, being initially expressed in different scales; 2) a weight was assigned to each variable, based on expert evaluation, expressing the impact of the variable in each scenario (0: no influence, 1: indirect influence, 5: direct influence, 10: high influence). Data values were multiplied by the weight assigned to each variable and then normalised again; 3) for each MU, the normalised values of variables were summed up resulting in a multi-criteria suitability index ranging from 0 to 1 for each scenario. The farms having the highest indexes were considered as the most suitable for each specific scenario.

## Results and discussion

Figure 1 shows the result of the cluster analysis. The dendrogram was used for choosing the optimal aggregation level, at which the differences were the highest between groups, and the lowest within groups. This allowed classifying the MUs in 4 groups (Table 2).

Figure 1. Dendrogram of the 13 management units.

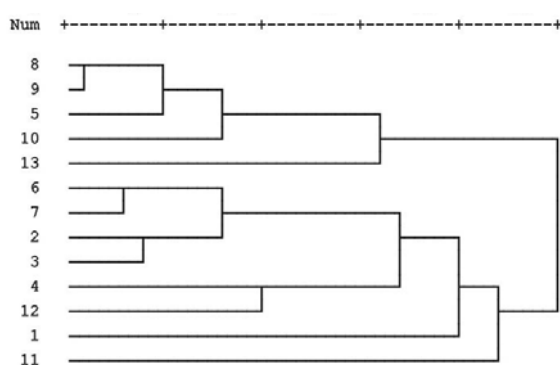

Table 2. Classification of the management units in 4 groups based on cluster analysis.

Group	Management unit
A	8, 9, 5, 10, 13
B	6, 7, 2, 3, 4, 12
C	1
D	11

The factors influencing the classification are: stocking rate and numbers of lactating animals, amount of grazed area, pasture management type, presence/absence of milking animals and traditional cheese making equipment, number of workers, man-days, distance from lowland and the presence of touristic activities (catering service). Disaggregating the suitability of each MU, some differences emerged (Figure 2). No MU reached the unity value for each scenario, suggesting that a wide improvement is possible for all the MUs.

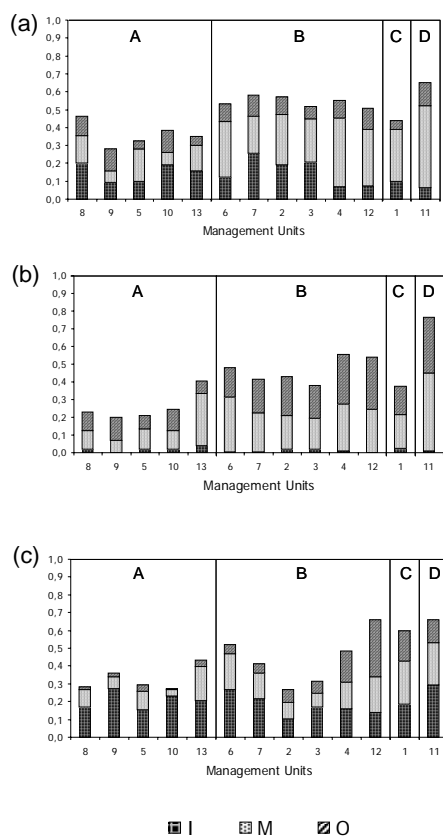

Figure 2. Suitability indexes of the MUs for each scenario: (a) Pasture; (b) Product; (c) Tourism. The contribution of the three categories: I = independent, M = manager, O = owner are indicated. The MUs are grouped based on the cluster analysis classification.

The pasture scenario was mainly influenced by independent variables or linked to management activities. Groups B and D were slightly more suitable than the others because of pasture characteristics and a quite good level of ordinary management. Independent variables had no impact on Product scenario having no power on productive activity. It depends mainly on managers' choices and on endowment provided by the owner. The low indexes of groups A and C were largely due to low stocking rate or absence of cheese making equipment. Concerning Tourism scenario, independent variables – as position of the *malga*, presence of panoramic viewpoints and hiking paths – had a great weight on the index

definition. Also tourist facilities, depending on owners, are very important to allow managers activities. In fact, MUs with lower index values have unfavourable position or limited structural investments.

## Conclusions

The results – addressed to managers, public owners and communities – could be used for proposing integrated development plans at territorial or regional level. The method could be applied also in other marginal areas where the Alpine farming system represents a viable opportunity of territorial development.

## Acknowledgments

This study was supported by an Interreg III; an Italy-Slovenia project “Models of sustainable development of agricultural and animal farming systems in Alpine areas for landscape preservation and valorisation of local products” (2003-2006).

## References

- Bovolenta S., Dovier S., Venerus S., Pasut D., Bottecchia C. and Parente G. (2006) A model of sustainable development for Alpine farming systems in N-E Italy. In: Biala K., Nösberger J., Parente G., Peeters A. (Eds) *Proceedings of the 13<sup>th</sup> Meeting of the FAO CHIEAM Sub-Network on mountain pastures* “Quality production and quality of the environment in the mountain pastures of an enlarged Europe” 15-17 September 2005 Udine (I)
- Janssen R. and van Herwijnen M. (1994) *DEFINITE: Decision on a FINITE set of alternatives*. Kluwer Academic Publishers, Dordrecht.
- Malczewski J. (1999) *GIS and Multicriteria Decision Analysis*. Wiley, New York.
- Pasut D., Dovier S., Bovolenta S. and Venerus S. (2006) *Le malghe della dorsale Cansiglio-Cavallo. Un progetto per la valorizzazione dell'attività alpicolturale*. ERSA (Gorizia, Italy).

# **Ley farming or permanent grassland ? A triple bottom line assessment**

Nevens F., Meul, M., Dessein J. and Van Passel S.

*Institute for Agricultural and Fisheries Research, Unit Agriculture and Society, B-9820 Merelbeke, Belgium*

## **Abstract**

Genuine sustainability assessment is all about realizing a triple bottom line: economic, ecological and social aspect should be reconciled, simultaneously and equally. In this contribution we present a farm sustainability radar in a context of its potential as a monitoring instrument to shine some sustainability light through the two systems in stake at this conference: permanent and temporary grasslands. Thereby, we incite an explicitly inter- and transdisciplinary approach, in which purely technical aspects as well as personal characteristics of the final decision maker should be considered.

Keywords: permanent grassland, ley farming, sustainability assessment

## **Introduction**

‘Sustainable development is development that meets the needs of the present without compromising the ability of future generations to meet their own needs’. This 1987 ‘Brundtland-definition’ is known worldwide, and at the cradle of the 21<sup>st</sup> century ‘sustainability’ seems to have gained a rightful place in the vision, mission and strategy of every self-respecting company, organisation or government (at least in a Western European context). This is obviously the case for agricultural practice and policy, also in Flanders (the northern region of Belgium). The local government as well as farmers organisations embrace sustainability as a principle, an attitude that is undoubtedly inspired by a certain ‘sense of urgency’. However, putting the theoretical concept and the undoubtedly well-meant proclamation of ‘sustainability’ into practice, into actual measures and actions towards adapted and/or new farming systems often proves to be lacking. Therefore, an interuniversity project (‘Stedula’) developed a system to concretise ‘sustainability’ for Flemish agriculture, using a theoretical framework of ‘transition’. A deliverable of this work was a monitoring tool for sustainability on dairy farms, by which the farm(er)’s activities can be assessed on their sustainability from an economic, ecological as well as a social point of view. In this contribution we present a farm sustainability radar in a context of its potential as a monitoring instrument to shine some sustainability light through the two systems in stake at this conference: permanent and temporary grasslands.

## **Materials and methods**

According to Rotmans (2005) and Elzen *et al.* (2004), a transition (towards a sustainable future) is long term and drastic change of a complex socio-technical system. The process should be based on a well conceived vision (with inspiring images of a desired future and based on guiding principles, agreed on by multiple stakeholders) and be followed up by the use of a well balanced indicator-based monitoring instrument (Kaplan and Norton, 1996). Thereby, genuine sustainability embraces –equally and simultaneously- ecological, economic and social principles and objectives. This ‘triple bottom line’ (Elkington, 1998) should always be kept in mind; sustainability practice and research should by no means be reduced to an

attitude of ‘compromising an economic activity with environmental (legislative) requirements’. A future vision for Flemish agriculture in general was expressed following a multi-stakeholder dialogue-project (Nevens *et al.*, 2007); the accompanying indicator-based monitoring tool – a ‘farm sustainability radar’ - was developed for dairy farms (Meul *et al.*, 2007). For a more detailed ‘manual’ of this instrument, we refer to the latter publication; for the current paper, we settle for the general (and simplified) sustainability radar and a number of its constituent themes (Figure 1).

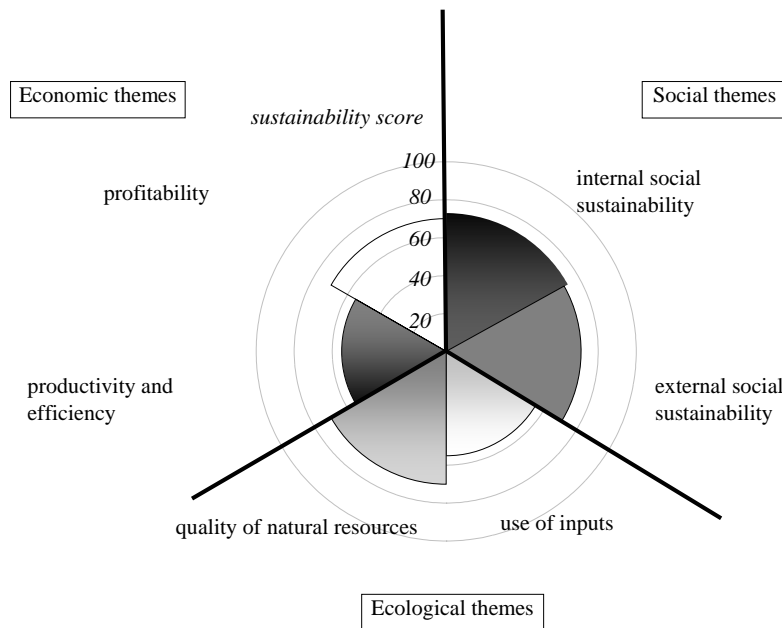

Figure 1. The simplified farm sustainability radar and its major themes

Considering these major themes of farm sustainability, we further balance some pros and cons of each of the two considered practices: permanent grassland and temporary grassland. We make a pragmatic choice to compare a system of permanent grassland (if necessary periodically resown) and permanent maize (P) on the one hand and a system of short term grassland (3 to 4 years) in rotation with feed crops (T) on the other hand. Thereby, the major objective is not give a decisive answer about which system is the best for each of the considered themes but to illustrate that genuine sustainability assessment urges a systemic approach, the use of many criteria/indicators and finally a well balanced choice, depending on the relative importance that certain stakeholders attribute to certain themes at a certain point in time.

## Results and discussion

### *Internal social sustainability*

One of the aspects that fit within the concept of internal social sustainability is professional pride: the extent to which a farmer is proud on his job and his activities. Thereby, craftsmanship and autonomy are major factors influencing professional pride in a positive way (Dessein and Nevens, 2007). Knowing that there are distinctive styles of farming corresponding with different styles of farmers (Van der Ploeg, 2000), it is clear that also this reality strongly influences a rightful choice for a T- or a P-system. No matter how obvious

scientific evidence in favour of a defined system may be, the ultimate choice is still the farmer's.

#### *External social sustainability*

A much-discussed topic of external social sustainability is landscape protection and management. In that perspective, the 'over-maization' of Flanders's rural areas raises questions in the public perception; during a few months of the summer season, the crop strongly disguises the surrounding landscapes for residents as well as tourists. Without disputing a relative freedom to decide on which crops to grow, being aware of different perceptions of different stakeholders on different aspects of a rural landscape (Rogge *et al.*, 2007) should be contributory in decision making on agricultural systems; and hence on the desirability of growing maize versus grasslands on certain locations.

#### *Use of inputs*

Growing silage maize in a ley-arable rotation (T-system) offers possibilities to save a significant amount of fertilizer N (Nevens, 2003), and at the same time save on the use of energy: a major part of consumed energy in dairy farming originates from indirect sources, of which mineral fertilizers are a major component (Meul *et al.*, 2007). Temporary grasslands and permanent grasslands (that can be kept in good botanical condition) can yield equally at equal N-inputs (Nevens, 2003). Summing up, the T-system could score better on use of inputs N and energy. Moreover - and specifically compared to continuous silage maize- a rotation offers beneficial non-N-effects that can be described to reduced disease or weed pressure, thereby reducing the need for chemicals. Meadows seem to have an outstanding 'cleansing' effect when inserted into a rotation (Tomasini *et al.*, 2002).

#### *Quality of natural resources*

The enhanced N-mineralization during the arable phase of ley-farming systems increases the risk of excessive nitrate leaching to ground and surface waters (Hatch *et al.*, 2004), which could partly be overcome by growing N greedy crops, able to scavenge the soil profile for N (Nevens and Reheul, 2002). Considering the risk of N-leaching from grassland, the choice for a P- or T-type rotation seems relatively inferior to the applied management system on the grassland (grazing versus cutting and adapted N-fertilization). In general, the soil OM in ley-arable systems is at a more optimum level than under permanent arable (maize) land (Grignani *et al.*, 2007), which is a good indication that soil physical and biological condition will be superior. Moreover, whereas under permanent grasslands a high amount of organic matter is stored but not actually used, the T-system farmer alternatively builds up and re-uses organic matter (and its mineralization products).

#### *Productivity and efficiency*

A major indicator of genuine economic sustainability is productivity, a parameter that expresses actual value added per unit of applied capital (financial, labour, land,...). Thereby, gross value added is the difference between the end value of the production and the costs of applied materials and intermediates. According to Nijssen (1996), a T-system of maize-grass farming offers no value added compared to a P-system of permanent grassland and permanent arable land; the higher yields of the maize and the possibility to save on applied fertilizer-N would not compensate for the higher costs of the more frequent resowing of the grassland (contract work, seeds, herbicides...) and the accompanying initial grass yield losses. Moreover, if the T-system would also imply a higher amount of man-hours, its labour productivity would be inferior to that of a P-system.

#### *Profitability*

This further derivative economic indicator also takes into account farm structural costs (such as depreciations of buildings and machinery) and can express how much income can actually



be attributed to the different types of applied capital: land, labour, own capital and management. Again, considering potentially higher costs of machinery capital (in case the extra work for resowing is not contracted) and a higher labour demand, the remuneration of these inputs could be lower in the T-system compared to the P-system.

## Conclusion

A well founded comparison of different systems of agricultural practice (in this case permanent grassland versus temporary grassland) asks for a multicriteria approach. Thereby, having the aspiration of establishing genuinely sustainability systems, economic, ecological and social aspects deserve equal and simultaneous attention. Such an approach urges for an explicitly inter- and transdisciplinary methodology, in which purely technical aspects as well as personal characteristics of the final decision maker should be considered. Therefore, working at sustainable systems asks for collaboration between ‘hard’ and ‘soft’ scientists and a healthy mixture of their respective methodologies.

## References

- Deinum B. (1981) Root mass of grass swards in different grazing systems. *Netherlands Journal of Agricultural Science*, 33, 377-384.
- Plauborg F. and Olesen J.E. (1991) Udvikling og validering af modellen Markvand til vandingsstyring i landbruget. Beretning nr. S-2113, 103 pp.
- Plauborg F., Andersen M.N., Heidmann T. and Olesen J.E. (1996) Markvand: A decision support system for irrigation scheduling. In: Camp, C.R., Sadler, E.J. and Yoder R.E. (eds.) *Evaporation and Irrigation Scheduling. Proceedings of the International Conference*, Nov. 3-6, 1996, San Antonio, Texas, ASAE, pp. 527-535.
- Søgaard K. (2002) Afgræsning med malkekøer i praksis. Danmarks JordbrugsForskning, DJF-rapport no. 68.
- Rotmans J. (2005) Societal innovation: between dream and reality lies complexity. Erasmus Research Institute of Management, Rotterdam, the Netherlands, 50pp.
- Elzen B., Geels F.W. and Green K. (2004) System innovation and the transition to sustainability. Edward Elgar, Cheltenham, UK, 315pp.
- Kaplan R. and Norton D. (1996) The balanced scorecard; translating strategy into action. Harvard Business School Press, Boston, USA, 322pp.
- Elkington J. (1998) Cannibals with forks. The tripple bottom line of 21st century business. New Society Publishers, Gabriola Island, Canada, 407pp.
- Nevens F., Dessein J., Meul M., Rogge E., Verbruggen I., Mulier A., Van Passel S., Lepoutre J. and Hongenaert M. (2007) 'On tomorrow's grounds', Flemish agriculture in 2030: a cas of participatory translation of sustainability principles into a vision for the future. *Journal of Cleaner Production*, in press.
- Meul M., Van Passel S., Nevens F., Dessein J., Rogge E., Mulier M. and Van Hauwermeiren A. (2007) An integrated farm sustainability tool: methodology and application on Flemish dairy farms. *Agronomy for Sustainable Development*, in press.
- Dessein J. and Nevens F. (2007) 'I'm sad to be glad'. An analysis of farmers' pride in Flanders. *Sociologia Ruralis*, 47(3), in press.
- Van Der Ploeg J.D. (2000) Revitalizing agriculture: farming economically as starting ground for rural development. *Sociologia Ruralis*, 40(4), 497 – 511.
- Rogge E., Nevens F. and Gulinck H. (2007) Perception of rural landscapes in Flanders: looking beyond aesthetics. *Landscape and urban Planning*, in press.
- Nevens F. (2003) Nitrogen use efficiency in grassland, silage maize and ley/arable rotations. Ghent University, PhD Dissertation, 231pp.
- Hatch D.J., Hopkins A. and Velthof G.L (2004) Nitrogen and phosphorus cycling in grass-to-grass resowing and grass-arable rotations. In: Conijn J. and taube F. (eds): *Grassland resowing and grass-arable crop rotations. Consequences for performance and environment*. Plant Research International, Wageningen, the Netherlands, Report 80, pp. 5 – 24.
- Tomasini C., Borrelli L. and Pecetti L. (2003) Influence of fodder crop rotations on the potential weed flora in the irrigated lowlands of Lombardy, Italy. *European Journal of Agronomy*, 19, 439 – 451.
- Nevens F. and Reheul D. (2002) The nitrogen- and non-nitrogen-contribution effect of ploughed grass leys on the following arable forage crops: determination and optimum use. *European Journal of Agronomy*, 16, 57 – 74.
- Grignani C., Zavattaro L., Sacco D. and Monaco S. (2007) Production, nitrogen and carbon balance of maize-based forage systems. *European Journal of Agronomy*, 26, 442 – 453.
- Meul M., Nevens F., Reheul D. and Hofman G. (2007) Energy use efficiency of specialised dairy, arable and pig farms in Flanders. *Agriculture, Ecosystems and Environment*, 119, 135 – 144.

# Multifunctionality of Agriculture and the future of extensive grassland production systems in European remote rural areas

Bergmann H.<sup>1</sup>, Dax T.<sup>2</sup>, Hovorka G.<sup>2</sup> and Thomson K.<sup>1</sup>

<sup>1</sup> *University of Aberdeen, Business School, AB24 3QY, Scotland*

<sup>2</sup> *Bundesanstalt für Bergbauernfragen, Marxergasse 2, A - 1030 Vienna, Austria*

## Abstract

Biodiversity-rich grasslands in European mountainous areas, such as Pinzgau-Pongau (Austria) or Caithness and Sutherland (Scotland, UK) are in danger of decline and/or afforestation due to the low level of agricultural profits and the budgetary pressures on public funds supporting grassland use in remote areas. On the other hand, there is growing societal demand for the multiple services of grasslands (e.g. high-quality sheep meat and beef, leisure resources, agro-biodiversity protection, etc.) especially in mountainous areas. This paper presents results from the FP6 EU project “Towards a Policy Model of Multifunctionality and Rural Development“ (TOP-MARD).

We highlight the importance of a “holistic policy approach” which integrates the concept of the Multifunctionality of Agriculture (MFA) into rural development policies. The comparison of two Case study areas identifies the structural differences and similarities of the chosen areas, and indicates which sector-specific policy approaches should be used to ensure the survival of rural viable communities based on tourism industries as well as biodiversity-rich grasslands. Furthermore, the comparison shows that extensive on-farm meat production and the financial recognition of services provided by farms is crucial for sustainable rural development. The comparison shows that high regional economic importance of nature-based tourism is often but not always an indicator of high MFA.

Keywords: Mountainous grassland, Multifunctionality of Agriculture, New Rural Paradigm, Scotland, Austria

## Introduction

Human activities, especially in many ecosystems of less-favoured areas of Europe have been beneficial to biodiversity and specifically to agro-biodiversity. In grasslands and other agricultural landscapes, for example, low-intensity management can and has led to high densities of species (Young *et al.* 2005). Due to the rich historical diversity of traditional agricultural production systems adapted to natural conditions, European ecosystems and cultural landscapes depend directly on traditional types of land use (Mühlenberg and Slowik 1997; Dömpke and Succow 1998). E.g. for Austria, Meyer and Wytrzens (1998) show that with ongoing reforms and continuous depopulation there might be a threat for afforestation or abandonment in mountainous grassland-dominated areas in the Alpine area. This paper presents some initial results from the FP6 EU project “Towards a Policy Model of Multifunctionality and Rural Development“ (TOP-MARD). The areas considered are the mountainous areas Caithness and Sutherland (CandS, part of the NUTS3 UKM41) in the far north of Scotland, UK, and the mountainous area of Pinzgau-Pongau (AT322) in the province of Salzburg in west Austria.

Although many factors are responsible for the decline of land use in low intensity agricultural regions, the root cause is invariably the general intensification of traditional agricultural production systems especially in mountainous areas caused by the introduction of changed

work practices, new agricultural technology and arguably the instruments of the CAP (in 1974 in the UK, in 1995 in Austria). As a simplified reference of drivers and responses shows, there is a strong link between biodiversity decline (spec. agro-biodiversity) and agricultural production systems influenced by common agricultural policy.

## Materials and methods

### *Multifunctionality of Agriculture – a definition*

This interlink is part of the recently developed concept of “Multifunctionality of Agriculture” (MFA). This concept implies that agriculture delivers not only physical commodities in the form of food and fibre but also non-commodities. In general non-commodities contribute to social and ecological objectives, included in rural development targets, by delivering a wide variety of services (e.g. agro-biodiversity, cultural landscapes, recreation services, etc.), thus meeting the actual needs of citizens. The services include the safeguarding of: viable rural societies, infrastructures, balanced regional development and rural employment, maintenance of traditional rural landscapes, and biodiversity, as well as more specific agro-biodiversity, protection of the environment and high standards of animal welfare as well as food security based on regional products rather than on imported products. (cf. Finnish Presidency of the European Union, 2006).

Apart from this political understanding and discussion of the term MFA, there is more and more scientific discussion about the term. The most frequently used definition of MFA - mainly based on the economic theories of external effects (c.f. Schmid and Sinabell 2004) - has been developed by OECD (2001, 7, bottom): "The key elements of multifunctionality are: i) the existence of multiple commodities and non-commodity outputs that are jointly produced by agriculture; and ii) the fact that some of the non-commodity outputs exhibit the characteristics of externalities or public goods, with the result that markets for these goods do not exist or function properly."

### *Grassland functions in Caithness and Sutherland and in the Pinzgau-Pongau*

Grassland in mountainous regions provides environmental goods and services which in most European countries have an obvious link between agriculture and the recreation industries. Therefore, changes in the way in which meadows and pastures are used by farmers as well as tourists have far-reaching effects on the cultural landscapes which are an input for agricultural as well as recreational industries (c.f. Bignal and McCracken 1996; 2000).

Geographically, Caithness and Sutherland (CandS) is a remote area very distant to the main European population centres of London, Paris, Frankfurt, etc., while Pinzgau-Pongau (P-P) is much closer to major cities such as Milano, Vienna and Munich, and is located within the famous tourist region of the Alps. It may therefore be expected that tourism and other leisure activities in P-P should be more important than in a remote area such as CandS. In both areas (see for further details Bergmann and Thomson 2006, and Dax and Hovorka 2006), we find that tourism industries are major employers. Whereas P-P offers a wide range of recreation facilities such as skiing in winter as well as hiking in summer, in CandS most tourism is concentrated in the months April to September, with hiking, sports shooting and other land-based recreation activities. In both areas, the most important employers by far are in the public sector, while agriculture is followed by tourism (here used the Figures from the economic sector “restaurants and hotels” as a proxy) (see also Bergmann *et al.* 2007, forthcoming).

## Results and discussion

Agricultural land use in both areas is marked by a large proportion of grassland (more than 98% of Utilised Agricultural Area in CandS and more than 99% in P-P). Especially the extensive use of grassland in the form of rough grazing and alpine pasture systems is widespread in both areas and reaches more than 40% of the total area. Both regions have only small proportions of crop areas (under 2% of UAA in CandS and less than 1% in P-P). In both areas the second largest land user is forestry, with 9% in CandS and 37% in P-P.

Farm structures in both areas are marked by specialised livestock farming: sheep husbandry in CandS and specialised cattle breeding and milk production in P-P. In particular, sheep husbandry has a long tradition in CandS, and in combination with sporting estates (deer hunting) has developed an unique landscape of extensive unfenced and unwooded areas.

The most important economic link between agriculture and recreation in CandS is based on bed and breakfast establishments, with some 60 farms (i.e. under 1%) offering this service, and the large estates offering sporting services, which cover about 50% of CandS, mostly in Sutherland. On the other hand, in P-P the existing livestock and specialised cheese production, combined with the skiing industry formed an unique landscape which is even more marked than the CandS landscape by a large degree of forestry involvement (more than 15% of all farms are “forest farms” and about 88% of all farms have at least some woodland) and the participation of farms in the bed-and-breakfast business (more than 1,600 farms, i.e. 35% of the farms in P-P).

Especially this described economic and social link between farms and recreation industries as one example of MFA is demanding for more integrated policy approaches. With positive experiences of the EU LEADER approach to rural development (OECD 2006, 94), there is a widely shared understanding among most rural actors and policymakers that all rural sectors have to contribute to rural development, particularly in peripheral regions, in order to attain appropriate farm household incomes and provide highly valued local environmental as well as tourist functions beyond agricultural production. With the inclusion of the LEADER approach into the new programming period of the EARFD 2007-2013 in both countries, it is now possible to even increase support for both inclusive measures targeted at agricultural competitiveness as well as the development of rural recreation industries. This recalls the core principles of the “New Rural Paradigm”, a holistic policy approach which can be understood in contrast to the “common practice” of former rural development policies on the following aspects:

1. the competitiveness of rural areas and the strengthening of local assets rather than concentrate on farm incomes and farm competitiveness,
2. inclusion of all sectors in the rural economy, esp. on rural tourism and the up- and down streaming businesses rather than concentrate on the agricultural sector alone,
3. the involvement of all levels of governments as well as on the wide scope of local stakeholders (multi-level governance) rather than to be based on farmer lobbies and specialised governmental branches.

## Conclusion

The long-term discussion on the tasks of mountain farms and on the development of appropriate support schemes has led to the recognition of these “services” by the local and wider society, and fostered the perception of mountain farmers to provide core aspects of MFA. In the mountain areas context analysed in the two case studies the management of grassland has far-reaching effects on the cultural landscapes. Through its close relationship to tourism these are understood as basic elements for quality of life and the rural economy of the

region. The comparison of the two study areas stressed the specific relationships developed through the predominant types of farm management in these LFAs between extensive grassland production and the regional economy.

## References

- Bergmann, H., Dax, T., Hovorka, G. and Thomson, K.J. (2007) Multifunctionality and Pluriactivity in Europe – a comparison between Scotland and Austria, Conference Proceedings of the ÖGA, Vienna, Forthcoming
- Bergmann H. and Thomson K.J. (2006) Study Area Report Scotland: Caithness and Sutherland, Working paper in the TOP-MARD Project, Aberdeen
- Bigal E.M. and McCracken D.I. (1996) Low-intensity farming systems in the conservation of the countryside. *Journal of Applied Ecology* 33 p. 413-424
- Bigal E.M. and McCracken D.I. (2000) The nature conservation value of European traditional farming systems. *Environmental Reviews* 8; p. 149-171
- Dax T. and Hovorka G. (2006) Study Area Report Austria, Pinzgau-Pongau, Working paper in the TOP-MARD Project, Vienna
- Dömpke S. and Succow M. (1998) Cultural Landscapes and Nature Conservation in Northern Eurasia. Naturschutzbund Deutschland, AIDEnvironment, and The Nature Conservation Bureau, Bonn, Germany.
- Finnish Presidency of the European Union (2006) The European Model of Agriculture - Challenges Ahead - A Background Paper for the Meeting of Ministers of Agriculture in Oulu 26.9.2006, [http://www.eu2006.fi/news\\_and\\_documents/other\\_documents/vko30/en\\_GB/1153824999785/](http://www.eu2006.fi/news_and_documents/other_documents/vko30/en_GB/1153824999785/)
- Meyer C. and Wytzens H.K. (1998) A Multidisciplinary framework for optimising the intensity of grassland management in mountain regions of Austria.; 2<sup>nd</sup> LSIRD Conference on Livestock production in the European LFAs, Bray, Ireland, Internetresource
- Mühlenberg M. and Slowik J. (1997) Kulturlandschaft als Lebensraum. Quelle and Meyer, Wiesbaden, Germany
- Organisation for Economic Cooperation and Development - OECD (2001) Multifunctionality: Towards an Analytical Framework. OECD, Paris.
- OECD (2006) OECD Rural Policy Review - The New Rural Paradigm Policies and Governance, Paris
- Schmid E. and Sinabell F. (2004) Modelling multifunctionality of agriculture – concepts, challenges, and an application; Discussion paper 08-2004; BOKU, Vienna, Austria
- Young J., Watt A., Nowicki P., Alard D., Clitherow J., Henle K., Johnson R., Laczko E., McCracken D., Matouch S., Niemela J. and Richards C. (2005) Towards sustainable land use: identifying and managing the conflicts between human activities and biodiversity conservation in Europe, *Biodiversity and Conservation* 14, p. 1641-1661

# **Environment friendly and sustainable dairy systems in the Atlantic Area**

Pflimlin A., Chambaut H., Raison C. and Le Gall A.

*Institut de l'Elevage, 149 rue de Bercy, 75595 Paris cedex 12, France*

## **Abstract**

Within the framework of a European project aiming to determine the impact of dairy systems on nitrogen and phosphorus surpluses at farm and regional levels, three types of tools were mobilized: experimentation, monitoring of pilot farms, modelling and mapping at regional scale.

Three different situations have been observed. In the North, the grazing systems are based on permanent grassland with a large grazing period; the surplus is close to 250 kg Nha-1 on dairy farms but the water quality is still good. In the south, the dairy farms are becoming very intensive but use only a small part of the area, so there is no problem of water quality yet. In West of France, despite less intensive dairy farms, the nitrate content in surface water is over 30 mg/l on average; the N surplus is high as well as the proportion of annual crops. These results show the importance of taking into account the diversity of environments and forage systems to interpret the collected data and thus, to enable a more appropriate implementation of European regulations in the field of the environment especially for water quality.

Keywords: dairy farms, NandP surplus, water quality, regulation, sustainability

## **Introduction**

The dairy sector of the Atlantic Area represents approximately 25 % of dairy production and of the territory of EU15. Recent European regulations, in particular the Nitrates Directive (1991/676 EEC) and the Water Framework Directive (2000/60 EC) aimed at obtaining before 2015 a good state of inland and marine waters, will reinforce constraints on these livestock systems to limit the risks of pollution. Moreover, the CAP 2003 reform has conditioned the attribution of European financial support to the cross compliance of regulations and in particular to the two above mentioned directives.

Confronted to this common environmental regulation, the diversity of environments and livestock systems, between Ireland and Portugal for example, appears considerable and justifies regional adaptations for better ecologic and economic efficiency. It is the objective of the Green Dairy project, a European Interreg III B project coordinated by the Institut de l'Elevage, mobilizing eleven regions of the five countries of the Atlantic Area over a period of three years. We present here some results about (1) the diversity of dairy systems and mineral surpluses; (2) the distribution of the N surplus into water, air and soil in experimental farms, according too local conditions; (3) the contribution of dairy systems to N and P surpluses and their desirable evolution, given that it is the combination of risky systems with sensitive environments that must be avoided.

## **Materials and methods**

The Green Dairy project has mobilised 3 complementary types of tools and skills:

- 9 groups of pilot farms with volunteer dairy farmers to improve practices and feasibility,
- 9 experimental stations to measure and understand, mineral flows, especially nitrogen
- statistical analysis mobilising regional databases for an extrapolation at regional level.

It is the combination of these three approaches that constitutes the originality of the project. For the three actions, specific indicators have been used: (i) farm gate mineral balance to evaluate the global impact on air, soil, and water quality, (ii) field balance to be closer to water quality (OECD 2001).

The 3 work areas with the appropriate and common methodology have been steered by the Institut de l'Élevage with the support of European scientific experts and the participation of all the partners for procedure harmonisation, data collection and processing and results discussion. The full results have been published in the proceedings of the final seminar held in December 2006 (Pflimlin *et al.* 2006). We present here only the main points.



Map 1 Location of the partners and tools of the Green Dairy project

## Results

### 1. Diversity of dairy systems and N and P surpluses in the pilot farms

Green Dairy Regions	Herds		Concentrates (kg cow-1)	Areas			Farm gate surplus	
	Number of dairy cows	Milk (l cow-1)		AA (ha)	Grass / Maize / Crops (%)	Stocking rate per AA	Kg N ha-1	Kg P2O5 ha-1
SW Ireland	82	5500	580	58	100/0/0	2.1	240	18
SW Scotland	159	7500	2180	167	95/5/00	1.6	134	40
SW England	165	6600	1600	110	85/5/10	2.2	266	35
Brittany	45	6700	930	57	55/25/20	1.4	117	36
Pays de Loire	56	7100	1500	82	50/25/25	1.3	93	21
South Aquitaine	53	7900	1800	69	20/30/50	1.2	155	50
Basque Country	99	9000	3900	58	88/12/0	2.7	257	84
Galicia	74	8500	3600	32	55/45/0	3.0	349	163
NW Portugal	88	8700	3300	22	0/100/0	6.1	502	113

Table 1 Characteristics of the 139 pilot farms and surpluses of N and P (average per group). AA: Agricultural Area

The analysis of the results (Table 1) leads us to distinguish three major types of dairy systems corresponding to three geographical subsets:

- *In the North*, dairy systems are based on heavily fertilised permanent pasture with a large proportion of grazing. The most typical systems are located in the south west of Ireland where grazing represent about 75% of the annual diet. The nitrogen surpluses, calculated with the mineral balance (farm gate), are close to 250 kg N ha<sup>-1</sup> and correspond quite well with purchases of nitrogen fertilisers.

- *In the South West of Europe*, dairy systems in permanent housing and total mix ration (TMR) with 50% of concentrates take more and more importance. Land, fragmented, rare and expensive (compared to the price of concentrates) are some of the reasons for this. However, fodder production can be very high. In the north of Porto, double cropping with irrigated maize and two cuts of Italian Rye Grass can produce up to 25 tons of DM ha<sup>-1</sup> and thus feed at least 5 cows ha<sup>-1</sup>! In these systems, the purchase of concentrates constitute the main part of the N and P surpluses per hectare which can rise till 500 kg N and 120 kg P<sub>2</sub>O<sub>5</sub> ha<sup>-1</sup>.

- *The dairy systems of the western part of France* appear less intensive with lower stocking rates and less surpluses: about 100 kg N and 30 kg P<sub>2</sub>O<sub>5</sub> ha<sup>-1</sup> for Brittany and Pays de Loire. Consequently, very different surpluses of N and P have been highlighted, mainly due to the level of nitrate fertilizers inputs on grasslands in the north and to purchases of concentrates in the south. In these 2 groups of regions, still not or just recently involved in the vulnerable zones (Table 2), liquid manure storage capacity remains insufficient (2-3 months) to lead to

an optimisation of manure valorisation. The French systems with temporary grassland and maïze appear more sparing on these two inputs and clearly show lower surpluses per hectare. The manure storage capacity is also more important (4 to 6 months), following investments carried out during the last decade: most of the territory having been classified as NVZ since 1994.

## 2. Distribution of the N surplus in the experimental farms

In the experimental stations, a study of flows and losses of nitrogen (N) was carried out over the years 2004 and 2005 at different scales: farm, field, animal (housing, storage, grazing...). Leaching was measured with tools appropriate to each situation (ceramic cups, soil nitrogen content and modeling) whereas N gaseous emissions have been estimated with emissions “coefficients” from the literature. The analysis of these results, consolidated by those from the bibliography, makes it possible to distinguish two main situations summarized in the Table 2.

Table 2 Distribution in experimental farms of the N surplus. Summary of the two main systems

(1) : farm gate surplus

	Permanent grassland	Forage crop		Permanent grassland	Forage crop
Stocking rate (LU / ha)	2-2.8	1.5-2	N surplus (kg ha <sup>-1</sup> )	200-300	100
Mineral N ha <sup>-1</sup>	200-300	50-100	N – NO <sub>3</sub> residue before drainage	50-60	60-100
Grazed grass / total diet	40-70	okt/40	N – NO <sub>3</sub> leached	15-30	40-60
% ploughed area year <sup>-1</sup>	<5	>40	NH <sub>3</sub> emissions (kg N ha <sup>-1</sup> )	40-60	25-30
% organic matter in soil	>10	2/jul	Other N emission (kg N ha <sup>-1</sup> )	30-40	okt/20
Default value, including denitrification +organisation	80-100	0			

*In grassland systems*, based on permanent grassland and loamy clay soils, the proportion of leaching is low, between 10 and 25% of the surplus, as long as this surplus remains lower than 250kg N ha<sup>-1</sup>. Conversely, gaseous losses are high with 35 to 65% of the total surplus and are related to the quantity of N cycling at the different stages.

*On systems based on forage crops in rotation*, the measured nitrate losses are greater and represent between 30 and 60% of the surplus, depending upon the intensity of winter drainage. Estimated gaseous losses are lower and vary accordingly to diet N content and to manure spreading methods. These results from experimental farms show that systems based on permanent grasslands in climate with wet summer, even with higher grazing occurrence, present fewer risks for water quality than forage crop based systems including a high rate of ploughing.

## 3. Contribution of the dairy herd to N and P surpluses

The dairy herd represents a very variable proportion of the livestock systems in the different regions. To estimate its contribution to N and P surpluses in these different Green Dairy regions, it was necessary to make a N and P balance for all the farming systems types (dairy, pigs and poultry livestock and crops) with harmonized references and a calculation method based on the 2000 agricultural census, common to the different countries.

For the global nitrogen balance, at various geographical scales, we have chosen the field balance (OECD 2001) where the main inputs are animal manures and mineral fertilizers. For the animal manures, we have chosen the French values, except for the dairy herd for which we have modulated the manure N according to the level of milk production, the protein content in the diet and the time spent grazing (Vérité, Delaby 1998). From pilot farms data and a simplified regional typology, we reconstituted the dairy herd N balance in 2 000.

Table 3 shows that the average nitrogen surpluses ranged between 30 and 86 kg N ha AA<sup>-1</sup> depending on the region. Lower values are found in Galicia and Southern West England while the highest value are observed in Brittany due to pig and poultry farms which account for



about 50% of the total organic N load in 2000. The lowest nitrate contents in surface water are found in regions which combine a low proportion of agricultural area, low surplus / ha, a high amount of permanent grassland and high winter drainage (typically Galicia).

Table 3 Environment characteristics, N surplus and nitrates in surface water in typical Green Dairy regions

	Winter drainage (climate/soil) (mm)	Environment AA % total area	Permanent Grassland (% AA)	Nitrogen surplus (2) ha AA <sup>-1</sup> (3)	Dairy % total surplus	Nitrate in water (1) (mg.l <sup>-1</sup> )	NVZ (% of the total area)
SW Ireland	600	70	80	53	60	15	100 since 2005
SW England	600	65	54	30	47	20	15
Brittany	400	65	10	86	48	33	100 since 1994
Pays de Loire	300	65	23	59	36	23	80 since 1994
Galicia	700	30	64	33	100	3	0
NW Portugal	800	35	25	53	37	5	-5

(1) Average content in surface water in 2000 (mg/l) (2) field balance

## Discussion

The impact of dairy mineral surplus varies largely between regions and farming systems. The partially land less dairy systems of the South are not very numerous and situated in regions where the forest covers two thirds of the territory. However, as an extension of NVZ is foreseen, derogation to the threshold of the 170 organic N ha<sup>-1</sup> would be fully justified, taking into account the forage production potential of these regions. However the input of purchased concentrate per cow and per hectare has to be reduced. Similarly, in the grassland regions, with grass yields of more than 10 T of DM covering the feeding needs of 2 cows per hectare, the threshold of 170 kg organic N often appears too restrictive considering the water quality, whilst there is no such a limit for mineral nitrogen in the nitrate directive regulation! Nevertheless a reduction of mineral N fertilizers and a better use of organic manure can improve the mineral balance without penalty to the stocking rate and the milk production per hectare. Conversely, in regions where the nitrate content in water is already high, combining an environment at risk with a high stocking rate and risky practices (proportion of annual crops), like in Brittany, the action margin is clearly more limited in relation to the Nitrates Directive or to eutrophication problems.

## Conclusion

Taking account of this diversity of environments and farming systems proves to be indispensable to make a diagnosis of regional significance and to improve the efficiency of the water regulation implementation. In risky environments, systems based on permanent grassland should be supported. But nitrates and phosphates are only one aspect of water pollution. Reducing pesticides use and fossil fuel consumption have also been checked in this study, as well as economic aspects in order to define more sustainable dairy farming systems, also on line with the Water Framework Directive.

## References

- OECD 2001, OECD Nitrogen balance database at <http://www.oecd.org/agr/env/indicators.htm>  
Pflimlin A., Chambaut H., Raison C. and Le Gall A. 2006 ;*Proceedings of the final seminar of the Green Dairy project Interreg IIIB n°100*. Rennes, December 2006, 118p.  
Verité R. and Delaly L. (1998) Conduite alimentaire et rejets azotes chez la vache laitière. Interrelations avec les performances. Renc. Rech. Ruminants 1998-5, 185-192

# Impact of Swiss agro-environmental policy on cattle farming and target species in the Entlebuch UNESCO Biosphere Reserve

Hofstetter P.<sup>1</sup>, Röder N.<sup>2</sup>, Bergamini A.<sup>4</sup>, Boltshauser A.<sup>3</sup>, Grandchamp A.-C.<sup>4</sup>, Keller Ch.<sup>4</sup>, Meduna E.<sup>4</sup>, Stofer S.<sup>4</sup>, Petermann R.<sup>1</sup>, Ruoss E.<sup>3</sup> and Scheidegger Ch.<sup>4</sup>

<sup>1</sup> Schüpfheim Agricultural Education and Extension Centre, Chlosterbüel 28, CH-6170 Schüpfheim, Switzerland

<sup>2</sup> TUM (Technical University of Munich) – Environmental Economics and Agricultural Policy, Alte Akademie 14, 85350 Freising, Germany

<sup>3</sup> Entlebuch UNESCO Biosphere Reserve, Chlosterbüel 28, CH-6170 Schüpfheim, Switzerland

<sup>4</sup> Swiss Federal Research Institute WSL, Zürcherstrasse 111, CH-8903 Birmensdorf, Switzerland

## Abstract

The study area is situated in the northern foothills of the Swiss Alps. 42% of the study area is covered with forest, 30% is agricultural area and the alpine zone makes up a further 18%. The farms are characterized by a small size (on average 15.2 ha). Nevertheless, 75% of the farms are full-time holdings. 34.3% of the working population works in the first sector. The impact of four agricultural policy scenarios (SC1: current situation, SC2: new agricultural policy 2011, SC3 and SC4: approaching to EU conditions without and with environmental payments) on land-use and on selected target species (selected butterflies, bryophytes and vascular plants) was analysed for different cattle farm types. Dairy farm income decreases from SC1 to 3 whilst, for breeding farms, SC2, 3 and 4 reveal to be most profitable. In SC4, beef farms operate with a low productivity level. Dairy farms usually have the highest stocking rate, breeding and veal farms the lowest. The effects of the change in area of six land-use types (intensive pastures, extensive pastures, mown meadows, nature conservation area, abandoned land, forests) under the 4 scenarios on target species (two butterfly species, four vascular plants, one bryophyte taxa) was estimated. In the long term, most target species will decline as parts of abandoned land will be transformed into forest.

Keywords: Mountain region, Swiss agriculture policy, cattle farming, economy, land-use types, target species

## Introduction

The new Swiss agricultural policy (Agrarpolitik (AP) 2011, 2005, Meier und Lanz, 2005) imposes a higher competitiveness and a stepwise approach to European conditions. According to AP 2011 and WTO negotiations, Switzerland is obliged to cut back tariffs, reduce product-bound internal measures of support and, in the medium to long-term, phase out any form of export aid. These measures are going to decrease the income of Swiss farmers, as Swiss agriculture is characterised by small-scale structures working with small herds in a high-cost context. For Swiss mountain regions, it is essential to analyse and quantify the nature and the magnitude of the impact of different political framework conditions on agriculture in general and on cattle farming, land-use types and target species in particular.

## Materials and methods

The study area, the Entlebuch UNESCO Biosphere Reserve, is situated in the northern foothills of the Swiss Alps and exposed to a sub-oceanic climate. The bedrock is calcareous. It consists of 42% of forest, 30% of agricultural area, 18% of alpine zone, 3% settlement zone and 7% of non-productive area. Due to its topography, soil, climate and remoteness, the Entlebuch has sub-optimal site qualities with respect to agriculture, industry and trade. In 2005 75% of the 1015 farms are full-time holdings and 34.3% of the working population is employed in the first sector (AfS, 2007).

The impact of four scenarios (SC1 to 4) on six real farms (management units) in 2005, typical for the Entlebuch, was analysed. Farm 1 (F1) to F3 represent different types of dairy farms. They vary mainly with respect to their size. The other three farms keep either suckler cow (F4), breed heifers (F5) or conduct a milk based veal fattening (F6). SC1 reflects the business environment in 2003/04. SC2 represents the implementation of the new Swiss agricultural policy (AP 2011; milk price decreases by 30% and meat price, on a slaughter weight basis, decreases by 20% in comparison to 2003/04, while costs remain constant). SC3 is an example for the total cessation of governmental intervention and SC4 represents the strict linkage of public payments to environmental services. The last two scenarios simulate market prices of milk and meat products as well as concentrate which are similar to European conditions in 2005/06. The costs in SC3 and 4 are kept on the same level as in SC1.

Statistical data and data about prices and costs were taken from the structural analysis of Hofstetter *et al.* (2006), Hilty *et al.* (2005), Wirz Handbuch (2005), Ammann (2004) and Meyer *et al.* (2003). Market prices in SC3 and SC4 were taken from Agrarmärkte in Bayern (2007, 2006). The labour requirement in terms of agricultural working units (AWU, man-work unit), the amount of direct payments and, on this basis, the agricultural output were calculated using a linear programming (LP) tool (Kantelhardt *et al.*, 2005). The LP tool tries to maximize the farm's specific performance. The consequences on economic parameters like gross margin and cash-flow, on changes in the production systems and on the use of agricultural area were evaluated.

Target species were selected to evaluate possible effects of these scenarios on organisms dependent on one or a few land-use types. Transition matrices which were developed in the LACOPE project (Fernandes *et al.*, 2006) show the relative change in land-use types (intensive pastures, extensive pastures, mown meadows, nature conservation area, abandoned land, forests) under the different tested scenarios.

## Results and discussion

In comparison to the status quo, the LP calculated that four farms produce milk in SC2, three in association with an additional production, while one produces meat (Tab. 1). Cash-flow per AWU markedly decreases from SC1 to SC3. Breeding, beef and dairy farms with pig fattening generate the highest income in SC1 and 2. Veal farms generate the highest income in SC3 in the majority of cases. The highest income per AWU is generated by beef and breeding farms. In SC3 (without direct payments), stocking rate is highest for F2, F3 and F5 farm types. But the need for agricultural area is essentially lower, because F1 needs only 9.6 ha, F2 13.2 ha, F3 8.6 ha, F4 7.9, F5 4.1 and F6 10.8 ha. In other scenarios with direct payments the LP showed that farmers would like to rent additional agricultural area, because the rent of 333 €ha<sup>-1</sup> is low for Swiss conditions. Farms have a very low or negative cash-flow in SC3. Economically, they wouldn't be sustainable. F2 (dairy farm) has the highest stocking rate across the 4 scenarios. The breeding farm (F5) and the veal farm (F6) are extensive production systems. Within a given scenario, the stocking rate generally decreases

from dairy to beef farm e.g. from F2 to F6. From SC1 to SC4 there is an increase of beef production together with a decrease of dairy farming and income.

Table 1. Influence of the 4 scenarios on production systems evolution, on cash-flow (€ AWU<sup>-1</sup>), on gross margin (€ AWU<sup>-1</sup>) and on stocking rate (LU ha<sup>-1</sup>) in the Entlebuch UNESCO Biosphere Reserve (Swiss mountain region)

Management unit <sup>1</sup>		F1	F2	F3	F4	F5	F6
Production system	SC1	Dairy <sup>2</sup>	Dairy	Dairy <sup>3</sup>	Beef <sup>2</sup>	Breeding	Veal
	SC2	Dairy <sup>2+</sup> Breeding	Dairy+ Fattening	Dairy <sup>3+</sup> Fattening	Beef <sup>2</sup>	Breeding	Dairy
	SC3	Veal	Veal	Veal	Breeding	Breeding	Veal
	SC4	Dairy <sup>2+</sup> Breeding	Veal	Veal	Beef <sup>2</sup>	Breeding	Veal
Cash-flow AWU <sup>-1</sup> , €	SC1	34000	53100	38500	53000	66000	24900
	SC2	30200	43800	23300	35000	41400	20200
	SC3	10800	16200	9700	-17500	-7800	-2900
	SC4	21300	33800	25000	23300	29800	17300
Gross margin AWU <sup>-1</sup> , €	SC1	45800	67500	52700	73600	110800	46200
	SC2	42700	66500	45500	57200	83700	45200
	SC3	18500	24900	20700	6200	30600	20000
	SC4	33400	42200	35700	44400	68900	38600
Livestock unit ha <sup>-1</sup>	SC1	1.2	2.3	2.3	1.7	0.6	0.6
	SC2	1.3	1.6	1.1	0.9	0.5	0.8
	SC3	0.8	1.9	1.7	1.4	1.7	1.4
	SC4	1.3	1	1	0.9	0.5	0.6

<sup>1</sup>Original farm size of the farm type F1 is 14.6 ha, 24.7 ha for F2, 13.1 ha for F3, 13.4 ha for F4, 20.8 ha for F5 and 24.9 ha for F6 in 2005. <sup>2</sup>These farms graze their cattle on alpine pastures. F1 exploits alpine pastures (36 ha) with some boarded animals from lowland farms (42 livestock units) for a 100 days period. The summering period for F3 on 20 ha lasts 120 days. <sup>3</sup>Average dairy farm with pig fattening.

As forests are strictly protected by the Federal law, these areas can not decrease. In fact, under all scenarios they will increase as abandoned land will slowly turn into forest. In scenario 2, the areas of mown meadows and extensive pastures decrease, forests and intensive pastures increase and the area of protected habitats remains unchanged. The most radical scenario (SC3) will lead to a marked increase in abandoned land and forest, a slight increase in extensive pastures and a distinct decline in mown grassland, protected areas and intensive pastures. SC4 undergoes the same changes in land-use distribution as SC3 but to a lesser extent.

The response of the target species to the different scenarios which influence the area of the land-use types can be classified in three categories: Short-term positive reaction: The butterfly *Lycaena helle* is most frequently observed on abandoned land. Thus, it will profit from the strong increase in abandoned land in all four scenarios. However, as abandoned land will eventually become forest, it will decline on the longer term. The two vascular plants *Succisa pratensis* and *Swertia perennis* are most often found on abandoned, wet land. Whether the increases in population size of these species are long-lasting again depends on the time it takes for the abandoned land to transform into forest. Neutral reaction: The butterfly *Colias palaeno* depends on the fodder plant *Vaccinium uliginosum*, which often grows in bogs which will not be influenced by SC1 to SC4. *Parnassia palustris* is a small vascular plant species which mainly grows on pastures and mown meadows in the study area. Presumably only a small decline in population size will be observed as long as the area of these land-use types remains quite large. In the same way, it is not probable that the population of *Splachnacea* will suffer as long as pastured areas do not decline dramatically. Negative reaction: The

butterfly *Boloria aquilonaris* depends on flower rich meadows on the edge of oligotrophic bogs. This species is already very rare and the population will probably decline further if conservation measures are reduced such as in SC3.

## Conclusions

The decrease of the milk and meat prices in scenario 2, 3 and 4 is the reason why the total incomes are decreasing essentially in scenario 2 and 4 and even more in scenario 3. Because of the framework conditions (similar EU-prices and without direct payments) there is no sustainable development in economy and society in scenario 3 since there is around a third of the Entlebuch population working in the first sector. This shows that direct payments are essential for the existence of agriculture in mountain regions. In scenario 2 (AP 2011) dairy farms also get direct payments for roughage consuming livestock and there is an extra-payment for cheese production. Therefore more farms are changing to milk production. This is coherent to the Swiss political goal, which intends to strengthen milk production. In scenario 4 (only environmental payments and a similar EU-price) the farms are mainly producing meat. The use of agricultural area is less intensive which is beneficial to the target species in the short term.

In the short term, target species population changes in the Entlebuch will be rather low, although extensive and intensive pastures and mown meadows, which are the most species rich land-use types in the Entlebuch, will decrease in size. Target species population sizes in these land-use types will decrease, but, as there is still a large area of these land-use types left, viable populations will most probably remain. In the long run, however, most target species will decrease since parts of the agricultural land will be abandoned and turn into forest.

## Acknowledgements

This study ([www.lacope.net](http://www.lacope.net)) was financed by SER (State Secretariat for Education and Research, SBF Nr. 01.0476-2).

## References

- AfS (2007) Statistisches Jahrbuch des Kantons Luzern 2007. *Amt für Statistik*, CH-6002 Luzern.
- Agrarmärkte in Bayern (2007, 2006) Jahresbericht 2006 und 2005. Bayerischer Bauernverband, Marktberichtsstelle – Max-Joseph-Str. 9, D-80333 München.
- Agrarpolitik 2011 (2005) Weiterentwicklung der Agrarpolitik. Eidg. Volkswirtschaftsdepartement, Bundesamt für Landwirtschaft, Vernehmlassungsunterlage, *BBL, Vertrieb Publikationen*, CH-3003 Bern.
- Ammann H. (2004) Maschinenkosten 2005. *Agroscope FAT*, Nr. 621, CH-8356 Ettenhausen.
- Fernandes J. P., Guiomar N., Riseth J.-Å., Oksanen L., Fülling F., Labba N., Aunapuu M., Johansen B., Kaule G., Mirek Z., Nikel A., Paul W., Tyran E., Röder N., Lederbogen D., Trautner T., Hofstetter P., Meduna E., Scheidegger Ch., Staehli I., Bergamini A., Stofer S, Fernandez F, Caballero R, Moreira M. B. and Brito O. (2006) Scenario approach. *Landscape Development, Biodiversity and Co-operative Livestock Systems in Europe*. *LACOPE*, Contract No.: EVK2 – CT-2002- 00150.
- Hilty R., Caenegem Van L. and Herzog D. (2005) Preisbaukasten. *Agroscope FAT*, Nr. 2.2005, CH-8356 Ettenhausen.
- Hofstetter P., Boltshauser A. and Ruoss E. (2006) Structural analysis of cattle farming and its development in the Entlebuch UNESCO Biosphere Reserve. *EGF, Grassland Science in Europe*, 11, 655-657.
- Kantelhardt J., Kapfer M. and Roeder N. (2005) A regional multi-agent model as a tool for modelling small structured agricultural land-use. *Proceedings of the 89<sup>th</sup> EAAE Seminar, Parma (Italy)*; 3.-5.02.2004; 737-757.
- Meier Th. und Lanz S. (2005) Agrarpolitik 2011 – Die Weiterentwicklung der Agrarpolitik. *AgrarForschung 12 (10): 436-441*, 2005.
- Meyer A., Nebiker B. and Schoch H. (2003) *Preiskatalog 2003*. LBL, Eschikon 28, CH-8315 Lindau.
- Wirz Handbuch (2005) LBL Lindau, Jahrgang 111, ISBN 3-7245-1328-3, Eschikon 28, CH-8315 Lindau.

# Grasslands in the Lublin Province before and after Poland's accession to the EU

Harkot W.<sup>1</sup>, Lipińska H.<sup>1</sup> and Wylupek T.<sup>2</sup>

<sup>1</sup>*Agricultural University, Department of Grassland and Green Forming, Lublin, Poland*

<sup>2</sup>*Agricultural University, Faculty of Agricultural Sciences in Zamość, Poland*

## Abstract

The paper presents the changes recorded in the arable land structure in the Lublin region in 1996-2006, i. e. after Poland's accession to the European Union. Grassland areas (pasture) were found to decline in their extent at this period and their management intensity changed, whereas semi-natural and one-cut meadows area increased. The abandoned or neglected grassland areas (no agricultural use) so far tend to come under the extensive management nowadays. The direct payments within P01 package (Maintenance of extensive meadows) and P02 (Maintenance of extensive pastures) are quite conducive to this process. The Lublin Province distinguishes itself in Poland by both, the number of applications submitted and the grassland area covered by the subsidies. Therefore, the changes in farm animals population (cattle, sheep, horses) and their effect on a grassland utilization mode were analysed.

Keywords: Lublin Province, land use, direction of changes, natural conditions

## Introduction

The Lublin Province is the furthest eastern part of Poland and since 01.05.2004 part of the EU, it borders Ukraine and Belarus. The region covers area ca 2.5 mln ha, that accounts for 8% of Poland total area (3<sup>rd</sup> largest out of 16 provinces). It is a predominantly agricultural region inhabited by about 6% of the total Polish population, 53% of economically active people work in agriculture. Owing to many years extremely low capital expenditure for agriculture in this region, it was classified into the poorest economically areas in the EU (Węsierski, 2005).

After Poland accession to the EU, the Lublin Province shows high dynamics of the structural changes in agriculture. This process has been assisted by the higher support levels in agriculture (Producer Subsidy Estimate) through various systems of direct payments, which also apply to permanent grasslands.

The objective of the present work was to present the changes in the permanent grasslands structure in the Lublin Province in the years 1996-2006 at the background of the changes in the agriculture structure owing to National Agri-Environmental Project that supports the rural area development.

## Materials and methods

The Lublin Province is situated in the south-eastern part of Poland. It includes 213 communities and 286629 farms of medium size 6.07 ha, including 5.21 ha of arable land ([www.stat.gov.pl](http://www.stat.gov.pl)). One of the characteristics of the province proves to be its highly diversified relief. The northern part is low-laying with abundant ground water resource, while the southern is of a hilly and upland nature (up to 394 m ASL) with clearly differentiated ground water level (often under 60 m). On the lowland, the river valleys spread wide, while on upland they appear narrow with steep slopes. The mean annual air temperature ranges

within 7.5–8.0 °C, whereas the absolute maximum air temperature is 39°C and minimum - 37°C. Annual amount of precipitation is found within 500–700 mm. The value and usability of soil is very differentiated. Both, the arable and meadow soils belong to six soil quality classes (I–VI). In the upland part of the voivodship, fertile soils developed from loess prevail, while in the lowland - weak podzolic soils formed from sand. The river valleys are dominated with alluvial soils, while some area depressions with bog soils and multi-species meadow and peat vegetation. Differentiation of the natural conditions is reflected in the land use structure as well as in the landscape.

The directions of the structural changes and their rate in the Lublin Province agriculture, after Poland accession to the EU, were presented on the grounds of the primary data supplied by the annual statistical publications concerning the Lublin province (WUS,1997-2006) and compared to the data from the national census of agriculture conducted in 1996 and 2002 (GUS,1997-2006). The impact of some changes in the structure of arable fields and animal head was analysed as well as in the area covered with the agri-environmental subsidies within P01 (Maintenance of extensive meadows) and P02 (Maintenance of extensive pastures) packages on the changes of the meadow and pasture area and utilization.

## Results and discussion

A typical characteristic of the Polish agriculture proves to be the disintegration of private farms, especially noticeable in the Lublin Province region, where the farms sized up to 5 ha constitute over 60% of the total number of farms (Brodziński and Chyłek, 2006). In the years 1996-2005 the process of farm area structure changes was very slow, particularly in a group of very big farms (>50ha). However, an upwards tendency was observed for small farms (up to 5 ha) and big ones share (10-50 ha) in the total number of farms at the expense of the middle-sized farms. Still, small and middle- sized farms (67.4%) prevail in the agriculture (Figure 1).

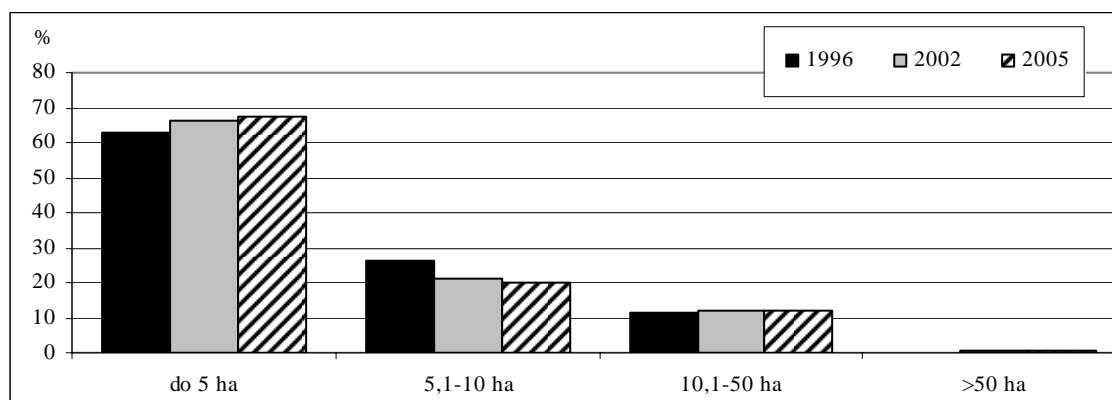

Figure 1. Private farms share (%) in total number of farms according to cropland area groups

The main reasons for slow concentration of land resources in big farms and progressing disintegration of the agricultural allotments, mainly in the attractive natural regions and in vicinity of big cities, are attributed to a serious deficiency of alternative nonagricultural income sources for farmers and the state negligence of the land management (Węsierski, 2005).

In the analyzed period, there was a decreased percentage of arable fields at the expense of forests and other nonagricultural areas in the land use structure. In the total arable land area, a pasture contribution declined (Table 1). From 1980 (the onset of the economy transformation in Poland) there has been progressing extensive management of the permanent grasslands. In

2002 as much as 30.8% of permanent grassland area in Poland was not utilized, including 8.1% pastures. At that time in the Lublin Province region, which is recognized as predominantly agricultural, this effect had a less extent as only 21.8% of meadow area and 5.1% of pastures were not in an agricultural use. The extensive management or even neglect of fodder production on great part of permanent grasslands both in Poland and in the Lublin Province over the past years resulted from a dramatic fall of the number of farm animals.

Table 1. Structure of land use in Lublin Voivodship in 1996-2006 (% total area)

Year	Total area	Agricultural lands					Forest and wood area	Other land
		Total	Arable lands	Orchard	meadows	pastures		
1996	100	67.4	53.5	1.3	10.2	2.4	21.9	10.7
2002	100	62.8	49.9	1.8	9.0	2.0	22.5	14.8
2004	100	59.3	47.7	1.9	8.0	1.7	22.6	18.1
2006	100	58.9	46.9	2.2	8.4	1.3	22.7	18.3

In 1980 in Poland, stock density per 100 ha of arable land decreased to 66.8 bovine animal units (in that 31.2 dairy cow units), 22.2 sheep units and 9.4 horse units, while in 2004 it was only 32.8 bovine animal units (in that 17.1 cow units), 1.9 sheep units and 2 horse units. Thus, the Lublin Province turned out to be a region characterized with the most dramatic drop in the number of cattle units in Poland. This tendency persisted till 2004 (Table 2). In the late 2004, the population of cattle at all age groups appeared lower as compared to the means of 1999-2003 and the most significant fall (by 22.7%) was recorded for cattle aged 1-2 years.

Table 2. Stock of cattle, sheep and horses per 100 ha of arable land in Lubin Voivodship in 1996-2006 (animal units)

Item	1996	2002	2004	2006
Cattle	33.7	27.9	26.5	28.5
in cow units	18.5	16.6	15.7	16.0
Sheep	2.1	1.7	1.8	1.8
Horses	3.8	2.8	2.8	2.8

Total reduction in the number of animal head resulted from low purchase price of live animal, milk and wool that lost profitability compared to the costs of essential production means, other goods and services as well as import of inexpensive high-subsidized dairy products and meat from the western European countries (Jankowska-Huflejt *et al.*, 2004). The years 2005-2006, after Poland accession to the EU, were marked by some stop in the sheep and horse head number drop when cattle stock per 100 ha of cropland increased, mainly young cattle group aged 1-2 years.

Since 2004 a steady upwards tendency of permanent grassland utilization for fodder has been recorded, the area of cut meadows increases. This situation arises from implementation of the agri-environmental projects within the Common Agricultural Policy of the EU Member States. The system of direct payments has moderated the costs of the crisis in farming management, particularly in permanent grasslands. A great number of private farms benefits from the payments supporting the organic and environmentally friendly production. The abandoned or neglected grassland areas (no agricultural use) have been extensive management-oriented assisted by the direct payments within P01 (Maintenance of extensive meadows) and P02 (Maintenance of extensive pastures) packages. The Lublin Province distinguishes itself in Poland with a number of applications submitted and grasslands area subsidized (Table 3).



Table 3. Permanent grasslands covered by agri-environmental subsidies within P01 and P02 packages in Lublin Province and Poland in 2004-2005

Name and code of package	Period	Application number		Area subsidized (ha)		Share (%) in total area grasslands	
		Poland	Lublin Province	Poland	Lublin Province	Poland	Lublin Province
Maintenance of extensive meadows (P01)	1.09.2004-15.06.2005	5483	1059	60518	6542	2.5	3.2
	1.08.2005-31.12.2005	1681	560	10132	1959	0.4	0.9
Maintenance of extensive pastures (P02)	1.09.2004-15.06.2005	684	53	6899	342	0.7	0.8
	1.08.2005-31.12.2005	149	49	434	112	0.05	0.3

## Conclusions

The data supplied by the national census of agriculture conducted in 1996 and 2002 and the Statistical Office in Lublin (1997-2006) confirms that the Polish agriculture has undergone structural changes. In the Lublin Province though, the changes prove slower compared to the western and northern part of Poland. The farms are still disintegrated and of low capital expenditure. The farms sized 50 ha and more account for only 0.3% of the total farm number. Unprofitable purchase price of live animal, milk and wool in comparison with the cost of production means over the period of economy transformation in Poland resulted in a decline of animal head number as well as extensive production of fodder on the permanent grassland areas finally leading to neglect any production on some part of them. After Poland accession to the EU, the crisis in agriculture has been moderated due to the direct payment system. The introduced agri-environmental packages applying to the permanent grasslands contribute to the decline of uncut meadows area and hold up their degradation.

## References

- Brodziński Z. and Chylek K. (2006) Evaluation of the direction of structural transformations in Polish agriculture. *Water-Environment-Rural Areas* 1(16), Wydawnictwo IMUZ, Falenty, 57-75.
- Central Statistical Office (GUS) (1997-2006) Użytkowanie gruntów, powierzchnia zasiewów i pogłowie zwierząt gospodarskich. Warszawa.
- Jankowska-Huflejt H., Zastawny J., Wróbel B. and Okularczyk S. (2002) Przyrodnicze i ekonomiczne uwarunkowania rozwoju łąkarskich gospodarstw ekologicznych w Polsce. W: Jankowska-Huflejt H. (eds.) *Perspektywy gospodarowania na trwałych użytkach zielonych w ramach Wspólnej Polityki Rolnej UE*". Materiały Seminaryjne, 49, 37-50
- Voivodship Statistical Office (WUS) (1997-2006) Użytkowanie gruntów, powierzchnia zasiewów i pogłowie zwierząt gospodarskich w województwie lubelskim, Lublin.
- Węsierski J. (2005) Prognoza rozwoju obszarów wiejskich województwa lubelskiego 2007 – 2020. Urząd Marszałkowski w Lublinie. Ekspertyza wykonana na zlecenie Departamentu Rozwoju Regionalnego UM w Lublinie.

# **Current status of legislation related to grassland renovation and grass-arable rotations in Poland**

Goliński P.

*Department of Grassland Sciences, August Cieszkowski Agricultural University of Poznań, Wojska Polskiego 38/42, 60-627 Poznań, Poland*

## **Abstract**

The paper focuses on the translation of EU nitrate and water framework directives into Polish legislation related to grassland renovation and grass-arable rotations. Almost 60% of Poland's total area is used for agriculture and is affected significantly by farmers' activities. One of them is grassland renovation and crop-arable rotations. These activities may influence the environment to various degrees depending on soil quality, local site conditions as well as on the intensity and concentration of production, especially milk and beef production. Environment protection is regulated by many international agreements, which Poland has signed, as well as by EU law that obliges all countries to prepare a Code of Good Agricultural Practice. Additionally, Poland is developing its own pro-ecological policy by establishing appropriate decrees on environmental management and use as well as by the elaboration of norms on admissible concentrations of various substances in the environment. This paper will try to give the scientific background of this legislation and the remaining uncertainties, questions and further research needed.

Keywords: environment, grassland, legislation, nitrate directive, socio-economical aspect

## **Introduction**

In sustainable forage production systems, the establishment of temporary grassland in rotation with arable crops, the resowing of permanent grassland after ploughing and other methods of grassland renovation should aim at developing a permanent botanical composition of the sward which becomes fine-tuned to the site yield potentials (Wachendorf and Goliński, 2006). The employed renovation methods and techniques can affect considerably the environment and, therefore, it is essential to carry them out in accordance with good farming practices. Particularly, ploughing and reseedling of grassland has become increasingly questioned with regard to environmental aspects such as nutrient loss and soil fertility. It is necessary to develop management rules for grassland management, e.g. renovation, which are acceptable for both farmers and society (Kemp and Michalk, 2005). Grassland cultivation is more and more challenged by increasing demands of legislation and society in terms of nutrient losses, conservation of biotic diversity, protection against erosion and carbon sink (Wachendorf and Goliński, 2006).

The aim of the paper is to present the current status of legislation related to grassland renovation and grass-arable rotations in Poland, in particular the study focuses on their impact on EU nitrate and water framework directives.

## **Legislation related to grassland renovation in Poland**

In Poland Grasslands occupy an area of 4.1 million hectares, which constitutes 21% of the total agricultural land or 13% of the entire area of the country (Goliński, 2006). Decisions concerning grassland renovations depend on the demand for high quality feed for ruminants.

In fact, it refers only to farms specialising in dairy cattle production. At the moment, no reliable data is available about the renovation scale of permanent grasslands and sowing of leys. On the basis of information obtained from the Polish Seed Chamber about the quantities and structure of sold seeds of grasses and legumes, it can be estimated, that in the last three years, seed mixtures were sown on the area of 90 000 ha annually.

There are no special regulations concerning grassland renovation in Poland, although the issue is mentioned in a number of legislative acts concerning agriculture. One of them is the Code of Good Agricultural Practice (Code, 2002) which comprises a number of recommendations concerning, among others, rational management of grasslands and the implementation of the Nitrate Directive.

### **The Code of Good Agricultural Practice**

EU law obliges Poland to prepare a Code of Good Agricultural Practice. The Code has been prepared in co-operation with agricultural advisers and representatives of agricultural organizations. It is supposed to be useful in introducing environmentally-friendly practices and in enabling the agricultural sector to develop in a sustainable way. The Code describes not only the main environmental threats likely to arise during agricultural production which may lead to unfavourable changes of physical, chemical and biological properties of the soil and water, but it is also a guide showing how to protect the environment in agricultural production. People responsible for agricultural policy and environmental protection should also be acquainted with the Code so that they are able to establish a balance between the level of agricultural intensification and the necessity of environmental protection.

The problems of grassland renovation are described in the Code in chapter entitled “Water protection from non-point source pollution – Agrotechnical methods for preventing water pollution” (Code, 2002). In this chapter, it is stated that permanent grasslands of degraded sward or sod should be renovated. The basic methods aimed at improving the sward are as follows: undersowing, if necessary with fragmentary damage of the old sward, as well as its proper management and fertilisation. Under exceptional circumstances, the sward can be ploughed and resown. If such an operation is done, considerable amounts of nitrogen that are released may pollute ground water, especially when its level is shallow. The number of agricultural treatments aimed at restoring the sward completely should be as few as possible and sowing must be completed so that the soil is completely covered with plants before the end of September. Grassland should be converted into arable land only in exceptional cases and taking into account the effects that the inevitable mineralisation of large amounts of nitrogen will have. When the sward is ploughed under, it is recommended to grow for the period of one year fodder plants characterised by high nitrogen requirements, for example rye for green fodder followed by maize as a secondary crop, so that grass can be resown in the optimal term. If precipitation in autumn and winter is greater than the water-holding capacity of the soil, the excess of rain water with nitrogen compounds diluted in it leaches to ground water and causes its pollution. It is necessary to remember that permanent grasslands, particularly those located within protective and sensitive zones play both productive and protective roles as regards open and ground waters.

In another chapter of the Code (2002) entitled “Protection of agricultural lands”, it is stated that changing land use from permanent pasture, grassland or forest to arable causes rapid decomposition of organic matter and the release of great amounts of easily-soluble organic and mineral compounds. Such a situation creates a danger of water contamination with substances causing its eutrophication or deterioration of drinking value. Regulation of water-air relations is very important on grasslands as they determine the development of desirable meadow plant species.

## Nitrate Directive in Poland

Council Directive 91/676/EEC of 12 December 1991 concerning the protection of waters against pollution caused by nitrates from agricultural sources was transferred into Polish legislation within the process of Poland's accession to UE with the assistance of numerous legal regulations:

- The Act on Environmental Protection from 27.04.2001,
- The Act from 18.07.2001 – Water Law,
- The Act on Fertilisers and Fertilising from 26.07.2000,
- Directive from 23 December 2002 concerning the criteria of determining water sensitive to contamination with nitrogen sources of agricultural origin,
- Directive of the Minister of Environment from 23 December 2002 about specific requirements to be fulfilled by guidelines aiming at limiting the discharge of nitrogen from agricultural sources,
- Directive of the Minister of Agriculture and Rural Development from 1 June 2001 concerning detailed ways of application of fertilizers and training connected with their application.

In accordance with the Nitrate Directive, areas have been identified and established in Poland on which waters sensitive to the contamination with nitrates of agricultural origin occur (Ministry, 2006). Monitoring results of surface and underground water quality showed very low contamination of surface waters with nitrates but in some regions of the country the quality of underground waters, especially ground waters (shallow) was considerably worse although since 1996 tendency for improvement has been noticed (Table 1). The aims of the Nitrate Directive concerning the protection of waters against nitrates correspond well with the Water Framework Directive (WFD) 2000/60EU.

Table 1. Nitrate pollution of underground water in Poland (% of monitoring results).

Nitrate (NO <sub>3</sub> ) content		Year	
		1996	2001
Underground water total	in range 25–50 mg dm <sup>-3</sup>	9.2	7.4
	above 50 mg dm <sup>-3</sup>	15.0	9.8
Underground water	in range 25–50 mg dm <sup>-3</sup>	3.0	2.0
	above 50 mg dm <sup>-3</sup>	3.7	2.0
Ground water (shallow)	in range 25–50 mg dm <sup>-3</sup>	14.1	12.1
	above 50 mg dm <sup>-3</sup>	24.8	16.7

On the basis of expert opinions elaborated with scientific institutes connected both with the departments of environment and agriculture which take into consideration, apart from results from the monitoring of waters also the condition of agriculture in our country, the total of 21 areas believed to be particularly exposed to nitrates of agricultural origin have been identified. The entire surface of this area amounts to 6263.25 km<sup>2</sup> which constitutes about 2% of the entire surface of Poland (Ministry, 2006). Special action plans are being introduced in these regions aiming at compulsory implementation of the Code of Good Agricultural Practice by farmers. The practices include compliance with appropriate principles and dates of fertilization, storage of natural fertilizers as well as production organization on farmland taking into account, among others, crop rotation and grassland renovation (Farmer Guidebook, 2006). In addition, areas have been determined in Poland which are exposed to potential risks of nitrate leaching and water contamination with nitrate compounds (Figure 1). From the point of view of grassland management north-eastern Poland is worrying. In this region, grasslands have the highest share in the structure of agricultural land. In Warmia and Mazury Voivodeship and Podlasie Voivodeship they reach the level of 30-32%. The north-eastern Poland is described as the region specializing in milk production based on grasslands, where their cultivation plays an important role.

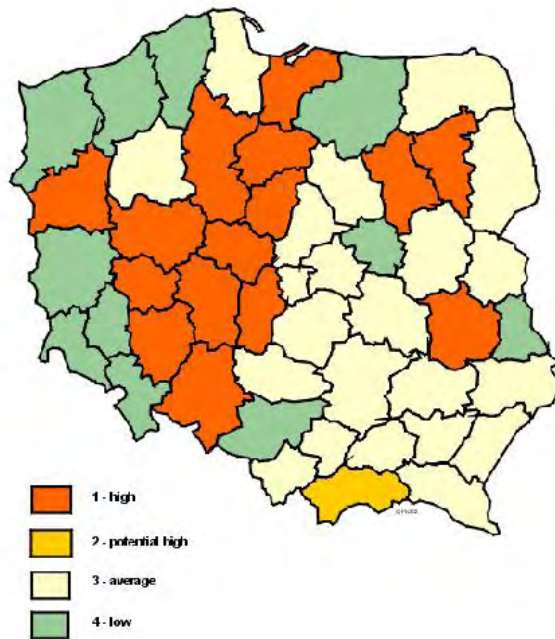

Figure 1. Risk classes of potential nitrogen losses supposed as the potential threat of water pollution with nitrogen compounds in Poland (Ministry, 2006).

Grasslands on farms specialising in milk production are renovated systematically every 5-6 years and large areas of leys are established. The stocking rate of dairy cows per 100 ha of agricultural land in that region in 2006 was 37.7 LSU, while the average stocking rate of dairy cows in Poland was 17.7 LSU (GUS, 2007). In such conditions, the potential risk of water contamination with nitrates is high and the farmers' compliance with good agricultural practices essential.

## Conclusions

There are no special regulations concerning grassland renovation and crop-arable rotations in Poland, although the issue is mentioned in a number of legislative acts concerning agriculture. One of them is the Code of Good Agricultural Practice which comprises a number of recommendations concerning, among others, rational management of grasslands and the implementation of the Nitrate Directive. Additionally Poland is developing its own pro-ecological policy by establishing appropriate decrees on environment management and use as well as establishing norms on admissible concentrations of various substances in the environment related grassland renovation.

## References

- Code (2002) Code of a good agriculture practice. Ministry of Agriculture and Rural Development, Warszawa.
- Farmer Guide-book (2006) Agriculture and Nitrate Directive EU. Farm management in particularly dangerous regions in Poland, Warszawa.
- Goliński (2006) Grassland renovation in Poland. *Report of the EGF-Working Group 'Grassland Resowing and Grass-arable Rotations'*, Wageningen (in press).
- GUS (2007) Agriculture in 2006. Main Statistical Office. Warszawa, [www.stat.gov.pl](http://www.stat.gov.pl)
- Kemp D.R. and Michalk D.L. (2005) Grasslands for production and the environment. In: McGilloway D.A. (ed) *Grassland: a global resource*, Wageningen Academic Publishers, The Netherlands, 193-208.
- Ministry (2006) Ministry of Agriculture and Rural Development. Warszawa, [www.minrol.gov.pl](http://www.minrol.gov.pl)
- Wachendorf M. and Goliński P. (2006) Towards sustainable intensive dairy farming in Europe. *Grassland Science in Europe*, 11, 624-634.

# **Economic evaluation of different land use alternatives: forest, grassland and silvopastoral systems**

Fernández-Núñez E., Mosquera-Losada M.R. and Rigueiro-Rodríguez A

*Crop Production Department, Escuela Politécnica Superior, Universidad de Santiago de Compostela, 27002. Lugo, Spain*

## **Abstract**

Economic evaluation including externalities of different land use scenarios is very important in order to recommend the best management alternatives for land-owners and for the general public. Silvopastoral systems can allow adequately the increase of woodland from agricultural land as they favour a multipurpose land use and allows economic returns on short, medium and long terms in a sustainable way. The aim of this study was to evaluate in the first years of the plantations the economic aspects (wood production), the environmental value (carbon sequestration + water protection + soil protection) and the recreational value (landscape + recreation areas) of different use alternatives of typical Galician area management: forestry, agronomic and silvopastoral, an integration of the two formers. Silvopastoral system increased land rent compared with agricultural land and forestry use.

Keywords: agroforestry

## **Introduction**

Agroforestry and more specifically silvopastures are sustainable ways of land management. Silvopastoralism is an ancient way of managing woodland and, more recently, a way of managing grazing land. It leads to: much faster increases in production than from woodland in the short, medium and long terms; biodiversity enhancement of pastures and, as a multi-product system, a sustainable use of land. Economic return from forests is realised over a long time frame. Often the first income will be from the first thinning. High costs are associated with woodland management activities such as clearing, pruning and fire prevention. Silvopastoral systems can generate income from woodland from the first stages of establishment (from the stock component) as well as reduce wood production costs, because clearing is not necessary and fire risk is reduced. In this paper, we evaluate the profitability of three different land use alternatives: woodland, grazing land and silvopastoralism.

## **Materials and methods**

Three scenarios were chosen based on the most important kind of land management farms in Galicia: exclusively forestry, traditional livestock farms and the alternative based on the combination of both of them: agroforestry systems. The *Forestry system* consisted of a plantation of *Pinus radiata* D. Don, initially with a density of 2,500 trees/ha to maximise volume production. The choice of this species is justified by the good market in the area for chip. *Traditional livestock farm system*: livestock management is based on pasture seasonal distribution availability (Mosquera *et al.*, 1999) in the region. Sheep were chosen because they are more compatible than other animals with tree production from the beginning of the plantation in silvopastoral systems. The grazing period was around seven months, the animals were fed with grass silage indoors for a five-month period. During the transition phases, animals were fed on pasture and silage during 15 days. Pasture and silage area were taken into

account in order to quantify the whole area needed for feeding sheep. *Agroforestry system*: two alternatives based on tree density (2,500 or 833 trees ha<sup>-1</sup>) were evaluated in the sylvopastoral system. The combination of tree and animal within the same area will last for seven and ten years depending on the previous mentioned densities, respectively, as it modifies tree cover and therefore pasture production. Pasture production was obtained from an agroforestry experiment (Mosquera-Losada *et al.*, 2006) developed in Galicia where pasture production as well as tree productivity was evaluated.

In order to evaluate the profitability of the systems, initial and maintenance costs as well as benefits were evaluated. Initial costs depend on the proposed system which includes land preparation (disc-arrowing and vegetation mechanical clearance) and plantation for the forestry system; land preparation, grass sowing, fertilization and animals for the traditional livestock farm. The same initial costs were taken into account in the agroforestry systems as well as protection for trees. Maintenance costs for the forestry systems were the pruning of 50% of trees, and the first (50% of trees) and second thinnings, as well as the final harvest. Maintenance costs for the traditional livestock farm were the vet, the shepherd, annual fertilization, silage making costs and resowing (every five years) and the animal replacement (every five years). Agroforestry system maintenance costs included the vet, the shepherd, annual fertilization, silage making costs, resowing (every five years), animal replacement and the same maintenance costs than for the forestry system.

The main benefits proceed from the annual selling of the livestock (lamb and sheep sold to maintain an adequate stocking rate in accordance with pasture production variation). Wood from thinning and final harvest was taken into account in the agroforestry and forestry alternatives.

All management practices in the different alternatives can be seen in Figure 1.

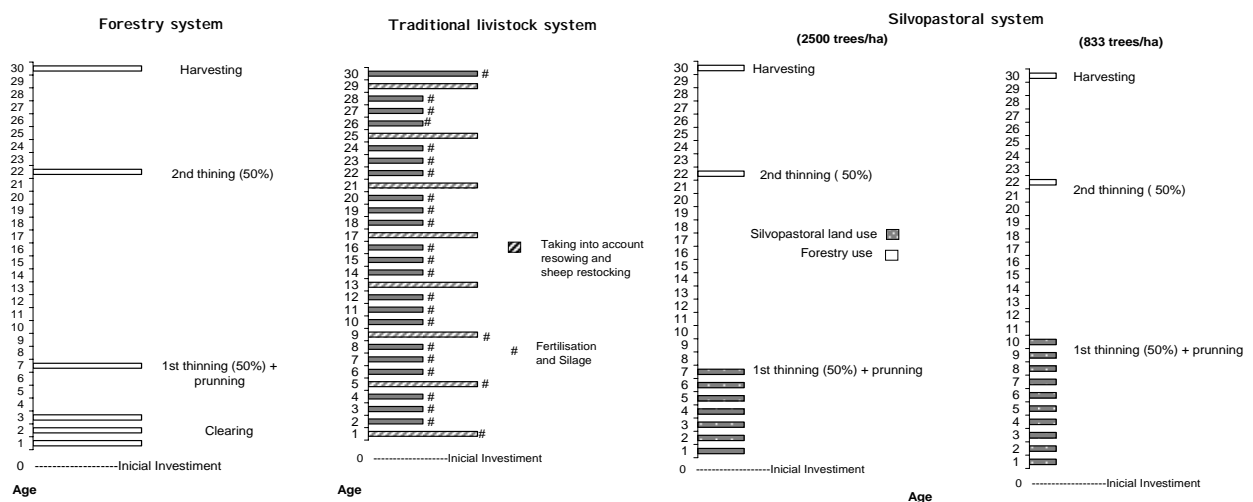

Figure 1. Management practices of the forestry, traditional livestock and silvopastoral systems.

The three scenarii were compared for a period of thirty years, needed for *Pinus radiata* final harvest. The economic analysis of such long-term alternatives requires the consideration of the opportunity cost of capital, or interest, over the investment period. One of the most common indicators used in forest-type investments is the present net value (PNV) (Davis and Johnson 1987) which is calculated as:

$$PNV = \sum_{j=1}^{i=n} \frac{R_j}{(1+r)^j} - K$$

where:

$R_j$  = cash flow;  $n$  = number of years of investment;  $r$  = discount rate ( $r = 2\%$ );  $K$  = initial investment.

## Results and discussion

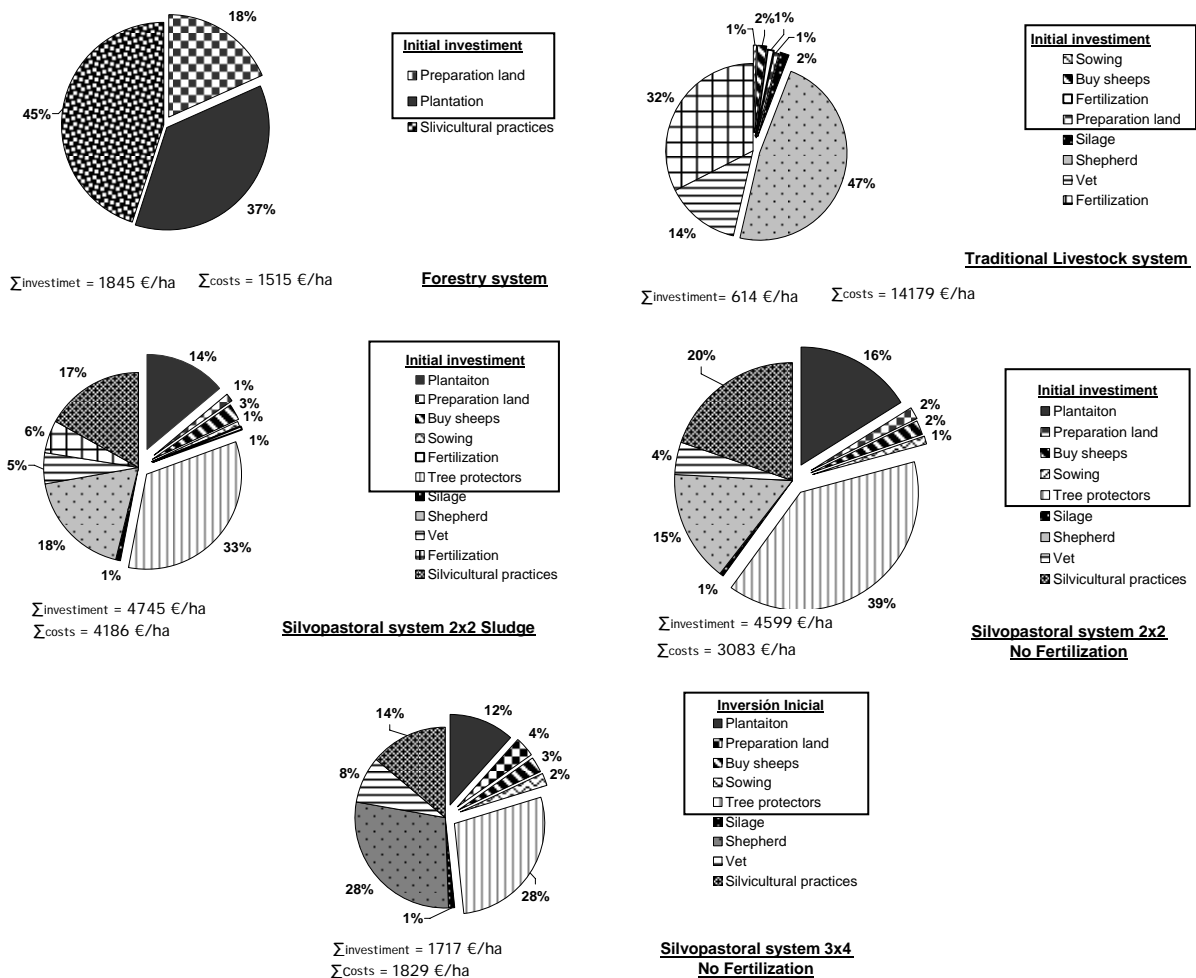

Figure 2. Investment and total costs of the three alternatives (Captions bordered by a square are related to initial investment).

Figure 2 shows the initial investment of the three systems. Initial investment is higher in the silvopastoral system 2x2, intermediate in 3x4 and forestry system and lower in the livestock system. The initial investment is mainly dedicated to buy animals (2% of total costs) in the traditional livestock system, but it is very low compared with the investment due to afforestation in those systems with trees (silvopastoral systems: 12-16% of total costs; forestry systems: 37% of total costs). Silvopastoral system costs are considerably increased by the need of tree protection to avoid animal damage (28-39%, depending on density). Maintenance costs are mainly allocated to personnel costs that are necessary for taking care of animals (47% of total in specialised livestock systems), but the proportion is much lower in



the case of silvopastoral systems. Around 50% of forestry maintenance costs are allocated to wood production practices (mainly clearance). When the productive value (consisting of selling of animals and tree products) for a period of thirty years is evaluated, the silvopastoral system with a low tree density had a production 17% higher compared with a traditional livestock system and 53% compared with a forestry system. When the silvopastoral system has a high tree density this Figures are reduced until 16% compared with forestry system but the traditional livestock is a 13% more productive. Galician estimation of recreation (landscape and recreation area) and environmental value (carbon sequestration and non-use value) are around 9% and 33% of the productive value (Xunta de Galicia, 2004) (Table 1).

Table 1. Benefits (production, recreation, environmental) and total economic value from the different systems

	Systems				
	Forestry	Agronomic	Silvopastoral		
	€/ha		(2500 trees/ha)		(833 trees/ha)
			NF	L	NF
Production value	5900	7731	6804	6845	9020
Recreative value	915	-	1056	1062	1400
Environmental value	3357	-	3871	3894	5132
Economic value total	10172	7731	11731	11801	15552

## Conclusions

Silvopastoral systems established at an adequate density which allows pasture use of forestry land for unless ten years improves the productive value of this land compared with forestry and agronomic exclusively land use, but also the recreative and environmental value. Silvopastoral systems could thus be considered as a good alternative for grazing land and woodland in Galicia when tree density is adequate

## References

- Davis L. and Johnson K.N. (1987) *Forest Management*. McGraw-Hill, New York, N.Y. 280 pp.
- Mosquera-Losada M.R., González-Rodríguez A. and Rigueiro-Rodríguez A. (2004) Fertilization with nitrogen and potassium on pastures in temperate areas. *Journal of range management*, 57(3) 280-290.
- Mosquera-Losada M.R., Fernández-Núñez E. and Rigueiro-Rodríguez A. (2006) Pasture, tree and soil evolution in silvopastoral systems of Atlantic Europe. *Forest Ecology and Management*, 232, 135-145.
- Proceedings of the International Conference*, Nov. 3-6, 1996, San Antonio, Texas, ASAE, pp. 527-535.
- Xunta de Galicia (2004) O monte galego en cifras. *Figures of Galician forestland*. Consellería de Medio Ambiente. 226 pp.

# The Rengen Grassland Experiment (1941 – 2006) and its contribution to grassland ecology

Schellberg J.<sup>1</sup>, and Hejcman M.<sup>2</sup>

<sup>1</sup>University of Bonn, Katzenburgweg 5, D-53115 Bonn, Germany

<sup>2</sup>Czech University of Life Sciences, CZ-165 21 Prague, Czech Republic

## Abstract

In 1941, the Rengen Grassland Experiment (RGE) was established on low-productive grassland dominated by *Nardus stricta* and *Calluna vulgaris* in the Eifel Mountains (Germany). Six treatments combinations of fertilizer nutrients were applied annually: an unfertilized control, Ca, CaN, CaNP, CaNP-KCl, and CaNP-K<sub>2</sub>SO<sub>4</sub>. Although plant species composition was identical in all treatments in 1941, long-term fertilization resulted in considerable diversification of the plant communities. Species characteristic for oligotrophic grasslands completely disappeared in all treatments with combined applications of Ca, N, and P. Multivariate analyses revealed that treatments explained the same variability percentage of plant species composition as selected soil parameters (content of P, K, Mg, N, pH, OM, C/N). P soil concentration was strictly dependant on P fertilizer application; long-term P depletion was observed in unfertilised treatments. On the other hand, accumulation of P in fertilised treatments still continues. The impact of soil P on floristic composition and species richness was much stronger than that of any other soil nutrient. Biomass production (first and second cuts) ranged in all treatments from 2.5 to 9.6 t ha<sup>-1</sup> and differed significantly between treatments as a long-term average.

Keywords: long-term fertilization, nitrogen, phosphorus, plant species composition, species richness

## Introduction

The Rengen Grassland Experiment (RGE, Figure 1a), set up by Prof. Ernst Klapp in 1941 on Rengen Grassland Research Station in the Eifel Mts. in West Germany, is one of the longest still running and well-designed grassland fertilizer experiment in the world. Initially, combinations of fertilizers should be tested as to whether they improve yield and forage quality on low-productive grassland. At that time, the prevailing acid grassland in that region was dominated by low-palatability species such as *Calluna vulgaris*, *Danthonia decumbens*, *Festuca ovina* agg., and *Nardus stricta*.

Some experimental results have been summarized by Becker (1956) in a PhD thesis. Further, Arens (1963) published data from the years 1953-61. Only 2 out of originally 7 blocks with each 5 replicates per fertilizer treatment have survived and have continuously been managed as a demonstration for university students. The RGE still illustrates a silent witness of grassland improvement for decades. Today it represents a solitary 'island' of extraordinary species-rich vegetation in a 'sea' of intensive grasslands of the Eifel Mountains.

A summary of the status of the experiment after more than 50 years of permanent treatment is given in Schellberg *et al.* (1999). Fertilisation strongly affected plant mineral content and the amount of nutrients removed under a two-cut system. Net energy for lactation and crude protein in plants varied significantly mainly due to changes in floristic composition. Soil

analyses exhibited significant differences with P but not with K. Recently, in 2005, plant species composition was analysed by means of plant cover estimation and by applying multivariate data analysis (Hejcman *et al.*, 2007a). Relationships between chemical soil properties, species richness and plant species composition were investigated in detail thereafter. So far, publications provided a brief systematic overview of the most interesting results from this unique experiment with respect to biodiversity conservation and future perspectives of long-term grassland experiments.

## Materials and methods

In 1941, the sward of the study site was dominated by *Nardus stricta* and *Calluna vulgaris*. The soil was cultivated using a grubber in order to create a seed bed and then reseeded with a mixture of productive grasses and herbs. The experiment was arranged in completely randomized blocks with five replications. Each block consisted of five fertilization treatments (Table 1). An unfertilized control plot was added in 1998 on a strip adjacent to the existing plots. This strip has not been fertilized or grazed since 1941 but cut when experimental plots were harvested and sampled. Individual plot size was 3 x 5 m. Details for type of fertilizer as well as soil nutrient determination are given in Schellberg *et al.* (1999).

Table 1. Amounts of nutrients (kg ha<sup>-1</sup>) supplied annually in the treatments since 1941 at the RGE

Treatment abbreviation	Applied nutrients (kg ha <sup>-1</sup> )	Nutrient
A	unfertilized control	
B	CaO=1000; Mg=67	Ca
C	CaO=1052; N=100; Mg=67	Ca/N
D	CaO=1309; N=100; P <sub>2</sub> O <sub>5</sub> =80; Mg=75	Ca/N/P
E	CaO=1309; N=100; P <sub>2</sub> O <sub>5</sub> =80; K <sub>2</sub> O=160; Mg=90	Ca/N/P/KCl
F	CaO=1309; N=100; P <sub>2</sub> O <sub>5</sub> =80; K <sub>2</sub> O=160; Mg=75	Ca/N/P/K <sub>2</sub> SO <sub>4</sub>

In Figure 1b, soil P data published in previous studies are compared. P was selected because of its generally high effect on plant species composition and species richness (Janssens *et al.*, 1998; Hejcman *et al.*, 2007b). Although the experiment was running for more than 60 years, stability of soil nutrient status could not be achieved in each plot. In fact, differences among treatments with and without P application increased substantially during the last 10 years.

## Results and discussion

Calculated by redundancy analysis (RDA), the effect of fertilizer treatment was found to be a significant predictor of sward structure in the experimental area and explained 62% of cover data variability (Figure 2). The largest difference in vegetation structure and composition was between the treatments without and with P application. Species characteristic for oligotrophic grasslands completely disappeared in all treatments with combined applications of Ca, N, and P. *Briza media* was the dominant short grass in control, B and C treatments.



a)

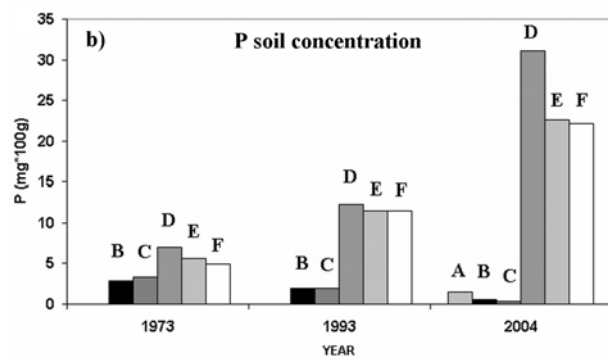

c)

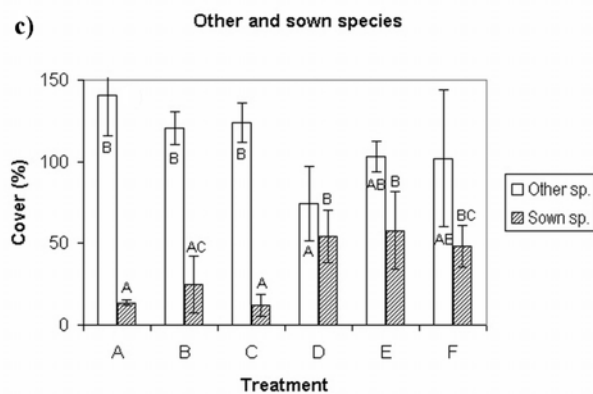

Species present only in treatments without P fertiliser were e.g. *Betonica officinalis*, *Carex* spp., *Linum catharticum*, *Helictotrichon pubescens*, *Potentilla erecta*, *Dactylorhiza maculata*, *Nardus stricta*, *Listera ovata*, *Platanthera bifolia*. *Lathyrus linifolius* was the dominant legume in the control and *Carex panicea* was the dominant species in the C treatment. Among treatments with P application, plant species composition was similar with tall grasses such as *Alopecurus pratensis*, *Arrhenatherum elatius*, and *Trisetum flavescens* dominating in the sward. *Lathyrus pratensis*, *Galium mollugo*, *Anthriscus sylvestris*, and *Bromus inermis* were present only in P fertilised treatments.

The multivariate analysis revealed that the explanatory power of measured soil parameters (P, K, pH, Mg, C/N, OM, N total) was almost the same like that of the treatment effect (61.7%), indicating that soil nutrient contents were decisive for the creation of different plant communities. The most powerful explanatory variable was that of soil P concentration followed by the soil pH. In contrast, species richness of vascular plants was significantly negatively affected by P soil concentration. Forage species reseeded in 1941 had higher total cover in treatments with P application in 2005. In the case of mosses highest cover was recorded in the control followed by treatments without P application (Figures. 1c and 1d).

Figure 1. (a) Aerial photograph of Rengen Grassland Experiment taken in June 2005, (b) the effect of treatment on phosphorus concentration in 1973, 1993, and 2004 - treatment abbreviations (A, B, C, D, E, F) are defined in Table 1, (c) cover of species naturally growing on the locality (other species) and species sown in 1941. Treatments with different letters in Figures c are significantly different.

Biomass production was strongly affected by fertiliser treatments. In 2005, the control and the treatments 'lime only' (A and B) did not differ significantly with mean biomass production ranging from 2.5 to 2.9 t ha<sup>-1</sup>. In comparison to the control, biomass production increased with the addition of other nutrients: 4.9 and 6.5 t ha<sup>-1</sup> in the C and D treatment, respectively, with both these treatments differing significantly from the A, B, E and F treatments. Highest biomass production was obtained under N, P and K fertilization, which was 8.9 and 9.6 t ha<sup>-1</sup> in the E and F treatments, respectively.

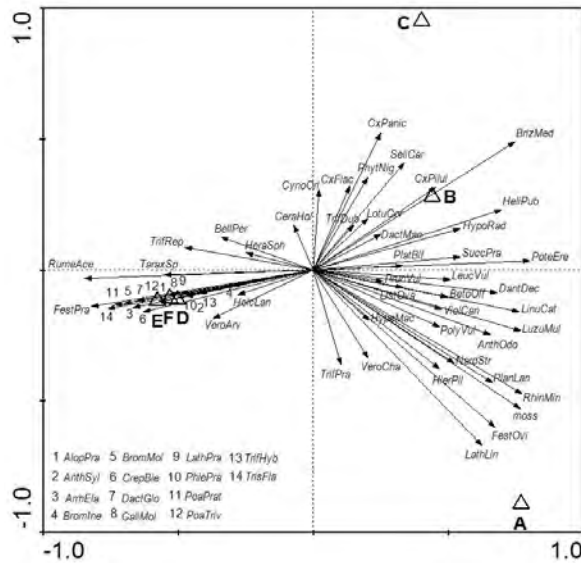

Figure 2: Ordination diagram indicating the result of the redundancy analysis of plant species composition data. Abbreviations indicate genus (4 letters) and species (3 letters) names.

## Conclusion

The RGE provides more than one important conclusion in view of the conservation of low productivity grassland. It was often argued that N enrichment is detrimental to vascular plant diversity. However, the RGE showed that this must not necessarily be the case if N fertilizer application is not accompanied by another limiting nutrient like P. The presence of two orchid species as well as *Briza media* and short sedges recorded in the N fertilized plots and the absence of tall grasses in the same environment support this conclusion. Further, the differentiation of P soil concentration among treatments is still in process even after 64 years indicating the necessity of long-term studies in grassland ecology.

## References

- Arens R. (1963) Umbruchlose Ödlandverbesserung mit und ohne Nachsaat. In: Arbeitsgemeinschaft zur Förderung des Futterbaus [AGFF] (ed.) Berichte über die Europäische Konferenz für Naturfutterbau in Berglagen, Zürich: AGFF, pp. 85-93.
- Backer H. (1956) Nährstoff und Reaktionszustand in Rengen Ödland-Düngungsversuchen. PhD thesis, University of Bonn, Bonn. 88 pp.
- Hejzman M., Klaudivová M., Schellberg J. and Honsová D. (2007a) The Rengen Grassland Experiment: plant species composition after 64 years of fertilizer application. *Agriculture, Ecosystems and Environment*, 119, in press.
- Hejzman M., Klaudivová M., Štursa J., Pavlů V., Hák J., Schellberg J., Hejzmanová P., Rauch O. and Vacek S. (2007b) Revisiting a 37 years abandoned fertilizer experiment on *Nardus* grassland in the Czech Republic. *Agriculture, Ecosystems and Environment* 118, 231-236.
- Janssens F., Peeters A., Tallowin J.R.B., Bakker J.P., Bekker R.M., Fillat F. and Oomes M.J.M. (1998) Relationship between soil chemical factors and grassland diversity. *Plant and Soil* 202, 69-78.
- Schellberg J., Möselers B.M., Kühbauch W. and Rademacher I.F. (1999) Long-term effects of fertiliser on soil nutrient content, yield, forage quality and floristic composition of a hay meadow in the Eifel Mountains, Germany. *Grass Forage Science* 54, 195-207.

# Restoring botanical biodiversity in permanent grassland – a targeted pro-active approach

Peel S.<sup>1</sup> and Diack I.A.<sup>2</sup>

<sup>1</sup>Natural England, Otley Road, Lawnswood, Leeds LS16 5QT, UK

<sup>2</sup>Natural England, Woodthorne, Wergs Rd, Wolverhampton WV6 8TQ, UK

## Abstract

Agri-environment schemes have had limited success in restoration of grassland biodiversity. We explain how, in the Higher Level element of the Environmental Stewardship Scheme launched in England in 2005, we have attempted to design and implement a scheme which may improve our success using science and evidence developed from long-term research and monitoring programmes. Compared with previous schemes HLS has more focused objectives, stricter eligibility and is targeted at sites offering greatest potential. It allows agreement-holders more flexibility but requires a commitment to a pro-active, interventionist approach. We summarise research findings which have been synthesised into decision support for targeting and prioritising sites, and into practical guidelines for advisers and farmers. These include the use of severe sward disturbance to create gaps for establishment of target species, addition of seed either direct or via spreading of green hay, and requirement to follow-up by grazing with cattle.

Keywords: grassland, biodiversity, agri-environment, botanical

## Introduction

Stevenson, Peel and Martin (2005), and Stevenson, Peel and Christian (2007) have described the development of the grassland component of Higher Level Stewardship (HLS), part of the new agri-environment scheme introduced in England in 2005. They focused on the methods used to identify grassland of high value, or high potential, for biodiversity. Here we focus on restoration of botanical diversity; we explain more about the monitoring and research background, the design of the scheme and how, on sites of high potential, we encourage agreement-holders to pro-actively restore grassland.

## Materials and methods

### *Species-rich grassland in England*

Of the 3 million ha of permanent grassland in England only approximately 3% (88,500 ha) qualify as species-rich grassland priority habitats within the UK Biodiversity Action Plan (BARS, 2007). Many sites are small: Hewins *et al.* (2005) found an average field size of 2.7 ha. They have escaped agricultural improvement, often because they are distant from farmsteads, too steep or rough. And for these reasons they are often not well-managed or are even abandoned. Their small size makes them particularly vulnerable to external impacts such as agricultural operations around the perimeter of the site, as well as rapid encroachment of scrub and bracken from field boundaries. They therefore require buffering, extending and linking. They also require suitable livestock systems to be sustained; this is difficult in areas dominated by arable cropping.

## *Agri-environment schemes*

Environmentally Sensitive Areas (ESAs) were designated from 1986: their aims were to conserve and enhance landscape character, the historic environment and public access, as well as biodiversity. One of their main priorities was to protect existing species-rich grassland and to start to restore species-richness on agriculturally-improved grasslands. Within ESA boundaries it was important to get as much land into the schemes as possible so normally any permanent grassland was accepted into lower ESA tiers. Eligibility for higher ESA tiers, and to the Countryside Stewardship (CS) scheme initiated in 1991, developed over time. Crucially, no assessment of soil suitability for botanical restoration was routinely made. Prescriptions were fairly rigid, no restoration plan was required and no botanical targets were set at individual agreement level.

From the mid-late 1990s there was a gradual increase in flexibility of the schemes; for example in some options the rigid limits on stocking rates were replaced by targets for sward structure. And entry criteria were raised. In particular we started assessing soil pH and nutrient status and giving priority to sites judged to have high potential (Stevenson, Peel and Christian, 2007) but this was only routinely applied from 2005 when HLS was launched and ESA and CS were closed to new entrants.

## **Results and discussion**

To a large extent, ESA and CS have succeeded in maintaining grassland sites of high existing value (e.g. Hewins *et al.*, in prep; Manchester *et al.* in prep.a). Increases in species-richness have been detected in some improved and semi-improved grasslands on chalk and limestone (Hewins *et al.*, in prep), and in hay meadows in Dartmoor ESA (Kirkham, Fowbert and Parkin, 2004) and Pennine Dales ESA (Critchley *et al.*, 2004). This enhancement has, however, been relatively slow and inconsistent. Monitoring in other ESAs (e.g. upland fringe grasslands, Manchester *et al.*, in prep b)) has shown little if any diversification in previously improved swards. Grassland in ESAs launched in 1987 have now been under extensive management for 20 years and the expectation at their launch was that restoration of species-diversity would occur much more rapidly than it has.

From the early 1990s research funded by the Ministry of Agriculture, Fisheries and Food was re-focused to directly support agri-environment schemes. It was already recognised then that there was a need to develop methods for re-introducing plant species into grassland. This resulted in a line of work which still continues today; progress was reviewed recently (Pywell *et al.*, 2006). The key findings are:

- Species-rich grassland (>25 species/m<sup>2</sup>) is overwhelmingly found on soil with an available phosphorus status which is low or very low by agricultural standards (Critchley *et al.*, 2002)
- Restoration of botanical diversity is primarily limited by lack of seed of desirable species in the soil seedbank or arriving from other sites (Walker *et al.*, 2004b).
- Successful seed introduction requires major disturbance of the existing sward to create sufficiently large gaps for establishment, and to reduce competition. This can be achieved by specialist slot-seeders, preferably with herbicide band-spray and mollusc control, or by use of normal disc or tine harrows to create approx. 50% bare ground. (Hopkins *et al.*, 1999)

- Seed can also be introduced using ‘green hay’ i.e. fresh herbage from a species-rich donor site, cut at or just before normal hay time (Edwards *et al*, in press).
- Some key species do not establish and/or survive successfully in the early years of restoration. This may be associated with inappropriate soil microbiota (Smith *et al*, 2003). Work is ongoing (e.g. Bardgett *et al*, 2007) to characterise the suitability of soils for botanical restoration, and to test the hypothesis that soil ‘facilitation’ by legumes and other species is necessary before more specialised species will establish.

These findings have been synthesised into a series of Technical Advice Notes covering choice of sites and methods, detail of methods and aftercare, e.g. Christian and Peel, 2004.

### *Design and implementation of Higher Level Stewardship*

HLS has, like ESA and CS, 10-year agreements. It also has a break clause at 5 years. But it has important aspects which distinguish it from the earlier schemes:

- A primary focus on ‘features’ of high environmental value. These may be existing or potential, e.g. species-rich calcareous grassland. The features, and their condition, are identified in an audit (the Farm Environment Plan) submitted with the application, and condition is reassessed at least twice in 10 years.
- Separate options for maintenance, restoration and creation of named features.
- More stringent eligibility criteria for entry to options (those for HK7 ‘Restoration of species-rich grassland’ are discussed by Stevenson, Peel and Christian, 2007)
- Flexible prescriptions that can be tailored to suit the site.
- Indicators of Success (IoS). Unlike prescriptions these are not legally binding. Their function is to make clear, for the adviser and the agreement-holder, the desired outcome. If the IoS is not being achieved the adviser will discuss possible reasons and may suggest changes to site management. If the IoS is not achieved in 5 or 10 years the adviser may recommend that the site is transferred to a different, perhaps less demanding and lower-paying option, or that the agreement is not renewed. An example of an IoS in HK7 is ‘*by year 5 at least 2 high-value indicator species for lowland calcareous grassland BAP habitat should be frequent and 2 occasional in the sward*’.
- A new policy on seed provenance (Stevenson, Christian and Peel, 2006). For restoration of semi-natural habitats only British-native (wild) species can be used. And adjacent to existing semi-natural grassland the seed should be of local origin. Based on Walker *et al* (2004a).

The design concept of HLS is to allow the agreement-holder the flexibility to deliver the desired outcomes in ways which suit the site and the farming business. But advisers are empowered to negotiate and make judgments on the suitability of, for example, the livestock system for delivery of the outcomes. In the case of HK7, which is the most popular field-scale option in HLS, the applicant must agree to an Implementation Plan, usually involving seed introduction by over-sowing or green hay spreading, and ongoing management by appropriate grazing, often by cattle.

### **References**

Bardgett R.D., Smith R.S., Shiel R.S., Tallowin J.R.B., Mortimer S.R., Brown V.K., Pilgrim E.S., Millward D., Lawson C., Harrison K.A., Edwards A.E., Hobbs P.J., Sanderson R., Harris, S.J., Beaumont D.A., Murray A.M.



and Quirk H. (2007) Diversification of grassland through manipulation of plant-soil interactions: the DIGFOR experiment. In: Hopkins J. *et al* (Eds). High Value Grassland *Occasional Symposium no. 39*, British Grassland Society, Cirencester.

BARS (2007) Biodiversity Action Reporting System. <http://www.ukbap-reporting.org.uk/>

Christian M. and Peel S. (2004). Sward enhancement: diversifying grassland by oversowing and slot-seeding. *Rural Development Service Technical Advice Note 29*.

Critchley C.N.R., Chambers B.J., Fowbert J.A., Bhogal A., Rose S.C. and Sanderson R.A. (2002) Plant species richness, functional type and soil properties of grasslands and allied vegetation in English Environmentally Sensitive Areas. *Grass and Forage Science*, 57, 82-92.

Critchley C.N.R., Fowbert J.A., Wright B. and Parkin A.B. (2004) *Upland hay meadows in the Pennine Dales Environmentally Sensitive Area: vegetation change between 1987 and 2002 and its relation with management practices and soil properties*. ADAS report to Defra.

Edwards A.R., Mortimer S.R., Lawson C.S., Westbury D.B., Harris S.J., Woodcock B.A and Brown V.K. (In Press) Hay strewing, brush harvesting of seed and soil disturbance as tools for the enhancement of botanical diversity in grasslands. *Biological Conservation*.

Hewins E. J., Pinches C., Arnold J., Lush M., Robertson H. and Escott S. (2005) *The condition of lowland BAP priority grasslands: results from a sample survey of non-statutory stands in England*. English Nature (EN) Research Report No, 636. EN, Peterborough.

Hewins E., Toogood S., Lush M., Anthwal V. and Mellings J. (in prep.) *Botanical survey of Lowland Calcareous Grasslands in Environmentally Sensitive Areas*. Draft Just Ecology report to Defra.

Hopkins A., Pywell R.F., Peel S., Johnson R.H and Bowling P.J. (1999) Enhancement of botanical diversity of permanent grassland and impact on hay production in Environmentally Sensitive Areas in the UK. *Grass and Forage Science*, 54, 163-173.

Kirkham F.W., Fowbert J.A. and Parkin A.B. (2004) *Hay meadow monitoring in the Dartmoor ESA 1995-2003*. ADAS Consulting Ltd report MA01016 for Department for Environment, Food and Rural Affairs.

Manchester S.J., Carey P.D. and Pywell R.F. (in prep). a) *Botanical survey of upland grassland in the Shropshire Hills, Blackdown Hills and South West Peak ESAs*. b) *Botanical survey of wet grassland in the Avon Valley, Upper Thames Tributaries and Somerset Levels and Moors ESAs*. Draft CEH reports to Defra.

Pywell R.F., Bullock J.M., Tallowin J.B., Walker K.J., Warman E.A. and Masters G. (in press) Enhancing diversity of species-poor grasslands: an experimental assessment of multiple constraints. *Journal of Applied Ecology*.

Pywell R.F. (2006) A literature review and gap analysis of grassland restoration research in the UK and Europe. Final report on RandD project BD1458 to Department for Environment, Food and Rural Affairs.

Smith R.S., Shiel R.S., Bardgett R.D., Millward D., Corkhill P., Rolph G., Hobbs P.J. and Peacock S. (2003) Soil microbial community, fertility, vegetation and diversity as targets in the restoration management of meadow grassland. *Journal of Applied Ecology*, 40, 51-64.

Stevenson M., Christian M. and Peel S. (2006) Seed sources for grassland restoration and re-creation in Environmental Stewardship. *Rural Development Service Technical Advice Note 53*.

Stevenson M., Peel S. and Christian M. (2007) The science behind the development of the Environmental Stewardship scheme grassland options. In: Hopkins J. *et al* (Eds). High Value Grassland. *Occasional Symposium no. 39*, British Grassland Society, Cirencester.

Stevenson M., Peel S. and Martin D. (2005) Agri-environment schemes in England: identifying and targeting semi-natural grasslands for management and restoration. In: Lillak R. (Ed) Integrating efficient grassland farming and biodiversity. *Grassland Science in Europe*, 10, 158-172. European Grassland Federation, Estonia.

Walker K.J., Hodder K.H., Bullock, J.B. and Pywell R.F. (2004a) *A review of potential effects of seed sowing for habitat re-creation on the conservation of intraspecific biodiversity*. Defra contract BD1447. Centre for Ecology and Hydrology, Monks Wood.

Walker K.J., Stevens P.A., Stevens D.P., Mountford J.O., Manchester S.J. and Pywell R.F. (2004) The restoration and re-creation of species-rich lowland grassland on land formerly managed for intensive agriculture in the UK. *Biological Conservation*, 119, 1-18.

# The protection and conservation of grasslands in the Polish Landscape Parks

Stypiński P. and Sienkiewicz-Paderewska D.

*Warsaw Agricultural University, Department of Agronomy, 02-776 Warsaw, Nowoursynowska 159, Poland*

## Abstract

Grassland's ecosystems are influenced both by natural processes (erosion, flooding and plant succession) and by anthropogenic factors (stopping of management, burning, change of utilisation, mineral fertilisation). This research indicates the threat intensity for permanent grasslands connected with the decrease of grassland area and the degradation of many rare plant communities. On the basis of field studies, carried out in the years 2004-2006 in the Landscape Park 'Podlaski Przełom Bugu' and of questionnaires which have been sent to all 120 Landscape Parks in Poland, it is possible to list the most harmful factors for permanent grasslands. The lack of utilisation seems to be particularly dangerous for plant communities. According to the Landscape Park's staff opinions plant succession and urbanisation (even for recreation purpose) also seems to be very harmful. Nature 2000 and agri-environmental programmes should help in grassland protection but in practice the results are not satisfying because farmers are still not very interested in environmental protection of their grasslands.

Keywords: Landscape Parks, permanent grassland, threats, environment, succession

## Introduction

The majority of Polish grasslands are semi-natural, anthropogenic ecosystems. An enormous biodiversity that results from a wide range of habitats is typical for them. However, grassland ecosystems are threatened both by natural processes (erosion, flooding and plant succession) and by anthropogenic factors (cessation of management, burning, change of utilization, mineral fertilization). That results in the decrease of rare plant and animal species and the degradation of many rare plant communities as well.

At present there are 120 Landscape Parks in Poland and they cover 2.6 million ha (8.3% of the country) (CSO, 2006). The purpose of their existence is to preserve the area that is extremely valuable due to its nature, history, culture and landscape (Journal of Laws 2004, No 92, item 880). A large number of different grassland functions (natural, social, economic) (Miazga and Mosek, 2001; Kozłowski *et al.*, 2000;) is coherent to the functions of the Parks, which especially predestine them for playing a significant role in the process of establishing sustainable development and Nature 2000 network in their area. Grasslands constitute a substantial part of the Landscape Parks, but their proportion is not exactly known. The data of CSO (2006) contain the percentage share of forest, agricultural land and waters in the landscape parks (Figure 1) only. Nature 2000 and agri-environmental programs should help in grassland protection but in practice the results have not been satisfying so far.

The aim of the study was to evaluate the area of grassland in the Landscape Parks and to identify the main threats for grassland ecosystems.

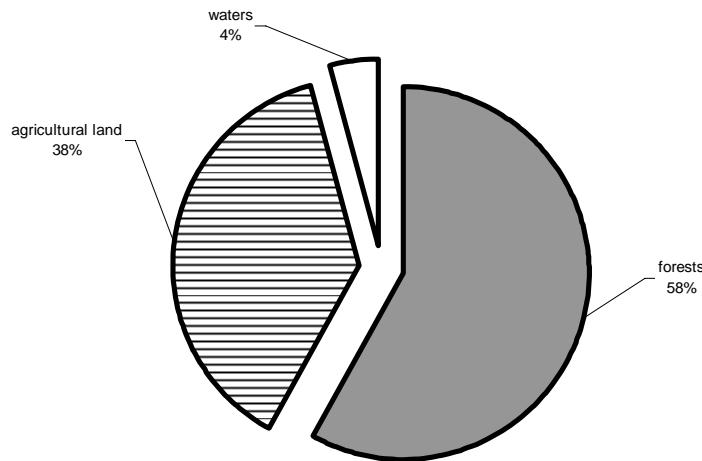

Figure 1. Percentage share of forest, agricultural land and waters in the landscape parks (CSO, 2006).

## Materials and methods

A survey addressed to the managers of every Polish Landscape Parks was conducted in 2005. In this paper the answers to three questions connected with grassland conservation are presented. The first question, referring to the local problems of the Parks' management, was: 'Are the grasslands located in the Park in danger or not? If yes, please mark what the origin of the threat is?' The respondents could choose among 30 given possibilities and could add other ones if they considered that they significantly affected grasslands. The second question was a continuation of the previous one: 'Which of the above mentioned threats could be especially dangerous for the Landscape Parks in Poland and for the grasslands in general?' It was an open question and the answer was optional. The percentage share of each of the mentioned threats was calculated. The third question was about the area of permanent grasslands in the Park. On the basis of the received data the average percentage share of the permanent grasslands in the area of the Parks was calculated. Regardless of the survey, the problem of grassland conservation has been evaluated on the example of one specific Landscape Park 'Podlaski Przełom Bugu' where more previous field studies had been done (Czarnecka *et al.*, 2004). Having the results of that study, it was interesting to see whether and how the situation has changed since Poland joined the EU.

## Results and discussion

The questionnaires were filled in by 95% of the Parks' managers. According to their opinion the cessation of utilisation, secondary succession, burning, lack of profitability of grassland production and afforestation were among the most often mentioned threats to grassland ecosystems (Figure 2). According to the second question it could be concluded that the cessation of utilisation and secondary succession were considered as the most dangerous factors and mentioned by about 50% of respondents Urbanisation (14.8%), soil drainage (13.9%) and grass burning were also mentioned but they were not such important in the local scale like cessation of utilisation and secondary succession. The third question was answered by 59% of the managers. The average percentage share of the permanent grasslands in the area of the Parks amounts to 11.43% which is almost the same Figure than in the whole country (CSO 2006) but it also indicates that even within Landscape Parks (environmentally sensitive area) it is very difficult to keep semi-natural grasslands.

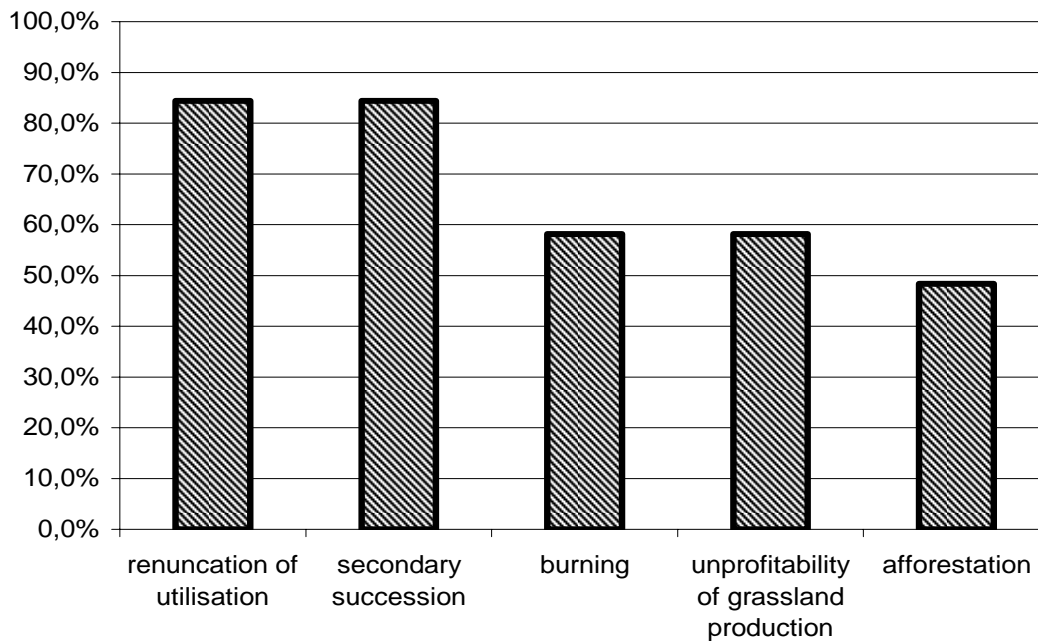

Figure 2. Main risk for grassland ecosystems according to the opinion of landscape parks' managers.

After becoming a EU Member State, Poland implemented agri-environmental programmes as a tool of proper, environmentally friendly management (Biuletyn Informacyjny, 2005). The field and case studies in the Landscape Park 'Podlaski Przełom Bugu' have shown however that less than 10% of agricultural land in this area is covered by those programs and only 4% of grassland has been included in agri-environmental agreements (Table 1).

Table 1. The realisation of Natura 2000 and agri-environmental programs in Landscape Park „Podlaski Przełom Bugu”

Name of the Nature 2000 area	Size of Natura 2000 (ha)	Area of grassland in agri-environmental programs (ha) (2005 and 2006)	Grasslands inside Natura 2000 (%)	Share of grassland in agri-environmental programs (%)	Number of farmers whose sign the agreements
<i>Dolina Dolnego Bugu</i>	21615.05	437.65	36	2.0	64
<i>Dolina Środkowego Bugu</i>	13123.68	459.07	51	3.5	64
<i>Dolina Tyśmienicy</i>	4759.58	200.66	76	4.2	64
<i>Lasy Parczewskie</i>	1629.31	101.27	12	6.2	13
Total / average	41127.62	1198.65	16	4.0	205

Official data from the Ministry of Agriculture and Rural Development (Biuletyn Informacyjny, 2005) also confirmed rather small interest of Polish farmers in active grassland

protection. Less than 1% of Polish farmers signed the environmental agreements with the Polish government. Protection of extensive cutting meadows (for example late and hand harvesting) and grazing pastures (low stocking rate, control of afforestation) is still not very popular. According to the opinion of Parks' managers, cessation of grassland utilisation is caused by many reasons but a low efficiency of animal production (especially the decrease of milk and beef production) could be one of the most important. Agriculture on the area of the Landscape Park is not profitable as we can see in Landscape Park 'Podlaski Przełom Bugu' (Czarnecka *et al.*, 2004) and it is a general phenomena observed also in Europe (Hopkins and Holz, 2005) that environmentally sensitive areas are not attractive for farmers. People often emigrate from these areas. Secondary succession and afforestation of grassland seem to be very harmful for grassland ecosystem biodiversity. Another threat for grasslands that is important, not only in Poland but also in whole Europe, is drainage and drying of swamps and peat meadows. On the basis of the results of our research, it could be concluded that this phenomena is observed in different parts of Poland.

Since 2007, special extra payments will be given to farmers who will decide to manage grasslands located on the environmentally sensitive area and in Natura 2000 zone. We hope that it will help farmers and that new agri-environmental programmes will make possible to keep our nice and often unique grassland ecosystems for future generations according to the principles of sustainable development.

## Conclusions

The cessation of utilisation, secondary succession, burning, lack of profitability of grassland production and afforestation are the most often mentioned threats to grassland ecosystems.

The field and case studies have shown that only 4 % of grassland has been included in agri-environmental agreements

Results of our study confirmed rather small interest of Polish farmers in active grassland protection even on area of Polish Landscape Parks

## References

- Biuletyn Informacyjny (2005) Ministerstwo Rolnictwa i Rozwoju Wsi ( ed) Ministry of Agriculture and Rural Development, 11-12.29-31.
- Central Statistical Office (CSO). (2006) *Environment 2006*. Statistical Publications House, Warsaw.
- Czarnecka A., Radecki A. and Stypiński P. (2005) The ecological knowledge of farmers located in National and Landscape Parks in Poland . *Grassland Science in Europe*. Vol.9, 1196-1198.
- Hopkins A. and Holz B. (2005) Grassland for agriculture and nature conservation : production, quality and multi-functionality *Grassland Science in Europe* vol.10., 15-29.
- Law of 16 April 2004 on the environmental protection. *Journal of Laws* 2004, No 92, item 880.
- Kozłowski S., Goliński P. and Golińska B. (2000) Non fodder function of grasses. *Grassland Science in Poland*, 3, 79-94..
- Miazga S. and Mosek B. (2001) Economical value and floristic differentiation of plant communities in Kosarzewka river valley. *Grassland Science in Poland*, 4, 107-117.

## Study on shrub encroachment in western Romanian grasslands

Sărățeanu V., Moisuc A., Butnariu M. and Stroia M. C.

*University of Agricultural Sciences and Veterinary Medicine of Banat – Timișoara, Romania, Calea Aradului 119, 300645 Timișoara, Romania*

### Abstract

The present state of most Romanian grasslands is deeply influenced by the agricultural activities of the communistic period, and of the present period too, because after 1989 a lot of these surfaces were irrationally used or abandoned. Additionally, the number of animals that are using these permanent grasslands decreased by more than a half in the case of dairy cows and sheep during the 1980-2004 period. These conditions determined deep changes in Romanian grassland vegetation structure and created favourable conditions for shrub encroachment, that have negative influence on the initial valuable vegetation, some of them becoming dominant in the vegetation cover. This work tries to develop a diagnosis tool for shrub encroachment short-term dynamics in grassland applicable for western Romania. For this purpose we have calculated an average spreading coefficient applicable for a range of species that are spread in this area as: *Prunus spinosa*, *Crataegus monogyna*, *Rosa canina*, *Rubus caesius*, *Sarothamnus scoparius*, *Amorpha fruticosa* and *Ononis spinosa*.

Keywords: shrub encroachment, grassland, vegetation, spreading coefficient

### Introduction

In Romania, erosion and landslides affect the biggest part of the grassland area (60%). Humidity excess and alkalinity affect every 10%, or less from the total grassland area. There are 379,000 hectares with parent material close to the surface, which are totally degraded grasslands (Moisuc and Đukic, 2002). In Timiș County and neighbour counties the situation is similar; only the size of the land area affected by degradation processes is different, depending on the specificity of the county's relief. In Caraș Severin County 80 % of grasslands are affected by soil erosion, in Timiș 36 % have humidity excess, in Hunedoara 21 % of grasslands have parent material close to the surface (Moisuc and Đukic, 2002). Undergrazing and the absence of maintenance work in grasslands lead to shrub proliferation on the grassland surface (Sărățeanu and Moisuc, 2004). We tried to develop a diagnosis tool useful to determinate a short-term dynamics of shrubs encroachment in grassland vegetation applicable for western Romania. For this purpose we have calculated a shrub average spreading coefficient applicable for a wide range of species from this area.

### Material and methods

Researches were realised during 2003-2005 on nine permanent grasslands situated in places with different environmental conditions from Banat region (western Romania). The data were collected twice a year: at the end of May and at the beginning of September. Research plots were situated at altitudes comprised between 87 and 370 m, on soils with pH between 5.4 and 8.0. The mapping of the aerial projection of shrubs on 100 m<sup>2</sup> (10 m x 10 m) plots was done by dividing the surface into 100 sub-plots (1 m x 1 m). For each sub-plot we have evaluated the area covered with shrubs (m<sup>2</sup>). The data obtained in this way helped us to analyse spatial distribution, and to calculate the coverage index for the studied species, which is the ratio of

the total area covered by shrubs (sum of the areas covered in 100 sub-plots) to the total area of the plot (100 m<sup>2</sup>). These data helped us to calculate the spreading coefficient, which represents the increase in area covered by shrubs starting from a reference area of 1 m<sup>2</sup> during two years (year<sup>-1</sup>). The Daget and Poissonet method (Moisuc *et al.*, 1995) was used to evaluate the vegetation. This method helped us to calculate some vegetation indexes as specific frequency (%), specific volume (%) and pastoral value (on a scale from 0 - grassland without economic value - to 100 - ideal grassland). The indexes of Shannon-Wiener (biodiversity index) and Simpson (dominance index) (Sutherland, 1977; Coste and Arsene, 2002) were also used. Statistical methods were polynomial regression and Bravais-Pearson correlation (Stanton, 1997; Coste and Arsene, 2002).

## Results and discussions

Altitude influence on shrub spreading coefficient is analysed with the help of polynomial regression and Bravais-Pearson correlation (Figure 1). The altitude range of the analysed grassland surfaces is comprised between 87 m and 370 m. Figure 1 shows the evident influence of altitude on shrub spreading coefficient ( $r = 0.72$ ).

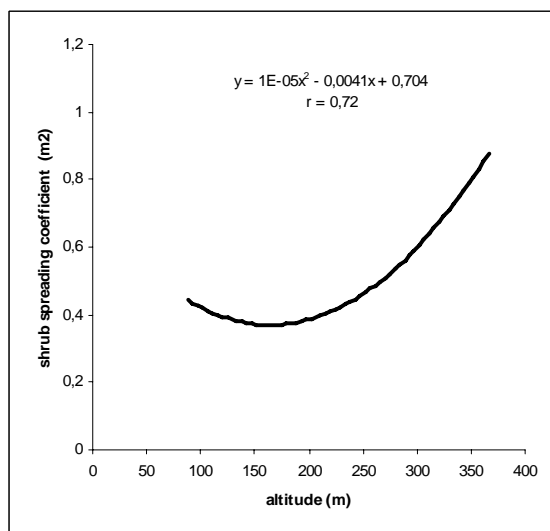

Figure 1. Correlation between altitude and shrub spreading coefficient.

Some researchers (Levine, 2000; Planty-Tabacchi *et al.*, 1996; Kotanen, 1997) are considering that the habitats with high biodiversity are rarely invaded compared with the vegetation communities with low species numbers. We have verified that these considerations are right in the case of Banat's grasslands.

Another aspect analysed is represented by the influence of shrub coverage index on Shannon-Wiener and Simpson indexes (Figure 2).

Figure 2 shows that there is no significant correlation between these variables in the case of Banat's grassland. Figure 3 shows the influence of shrub coverage index on the pastoral value. It can be noticed that there is no significant correlation between these two variables ( $r = -0.46$ ).

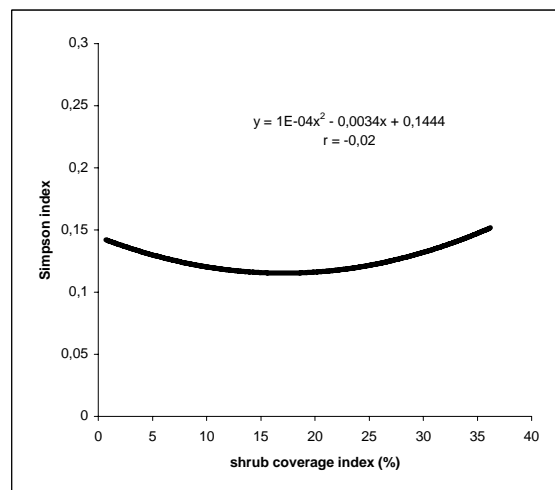
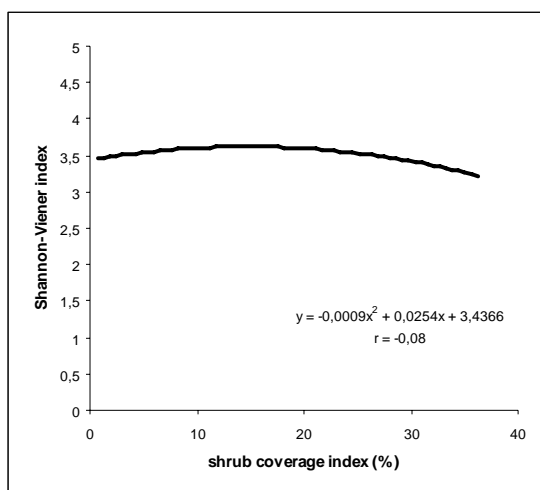

Figure 2. Correlation of shrub coverage index on biodiversity and dominance indexes.

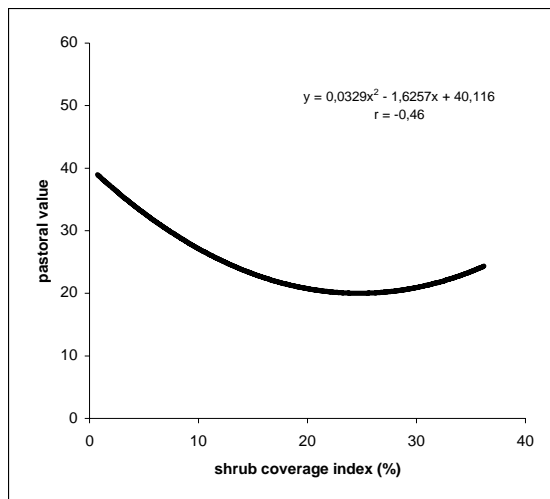

Figure 3. Correlation between shrub coverage index and pastoral value.

Another concern of this work is the influence of shrub coverage index on the main plant technological groups (grasses, legumes and plant species from other botanical families) Table 1.

Species	Technological group	Species number	Specific frequency (%)	Specific volume (%)
<i>Prunus spinosa</i>	Grasses	-0.22	-0.94	-0.91
	Legumes	0.90	0.40	0.13
	Other families	0.24	0.93	0.93
<i>Crataegus monogyna</i>	Grasses	0.03	0.08	0.12
	Legumes	0.78	0.38	0.19
	Other families	-0.02	-0.29	-0.23
<i>Rosa canina</i>	Grasses	0.40	-0.80	-0.89
	Legumes	0.37	0.15	0.12
	Other families	0.48	-0.82	0.94
<i>Rubus caesius</i>	Grasses	0.80	-0.92	-0.93
	Legumes	0.83	0.88	0.88
	Other families	0.91	0.92	0.92
<i>Sarothamnus scoparius</i>	Grasses	0.03	0.47	-0.87
	Legumes	-0.21	-0.25	-0.42
	Other families	-0.39	-0.36	0.83
<i>Amorpha fruticosa</i>	Grasses	-0.08	-0.12	0.41
	Legumes	0.52	0.19	-0.15
	Other families	0.81	-0.05	-0.38
<i>Ononis spinosa</i>	Grasses	0.83	0.92	0.72
	Legumes	0.02	-0.83	-0.85
	Other families	0.88	0.33	-0.57

Table 1. Correlation coefficients (r) between technological plant groups and shrub coverage index.

For this purpose, species number, specific frequency and specific volume are taken into account. The results differ among species, among plant groups and among vegetation features.

*Prunus spinosa* coverage index shows a positive correlation with legume species number and other family specific frequency and specific volume. The decrease of grass specific frequency and specific volume is determined by the increase of *P. spinosa* coverage index. In case of the shrub species, *Crataegus monogyna*, there is a positive correlation with legume species number. *Rosa canina* coverage index and other plant families are in close relationship ( $r =$



0.94). *Rubus caesius* has a positive correlation with the number of all technological plant groups; this is explained by the increase of annual weed number from the three technological plant groups, but the increase of this shrub species coverage index determinates the decrease of grass specific volume and frequency. *Sarothamnus scoparius* has a positive interrelation with other plant family specific volume, and a negative influence on grass specific volume. Between *Amorpha fruticosa* coverage index and other plant families species number is a positive correlation ( $r = 0.81$ ). *Ononis spinosa* has a positive influence on grasses and other plant family species number, and on grass specific frequency and specific volume; also, a negative interrelation is found for legumes specific frequency and specific volume.

## Conclusion

- The altitude between 87 m and 370 m showed a significant correlation on shrub spreading in western Romania;
- In the first stages of shrub invasion there wasn't any correlation with Shannon-Weaver, Simpson and pastoral value indexes;
- *Rubus caesius* had the greatest impact on vegetation carpet because there were highly significant correlations with all the plant groups analysed here.

## References

- Brown J.R. and Archer, S. (1999) Scrub invasion of grassland: Recruitment is continuous and not regulated by herbaceous biomass or density, *Ecology* 80(7), Ecological Society of America, p. 2385-2396.
- Coste I. and Arsene G.G. (2002) *Ecologie lucrări practice*, Editura Orizonturi Universitare, Timișoara.
- Heisler J.L., Briggs J.M. and Knapp A.K. (2003) Long-term patterns of shrub expansion in a C4-dominated grassland: fire frequency and the dynamics of shrub cover and abundance, *American Journal of Botany*, nr. 90(3), p. 423-428.
- Kotanen P.M. (1997) Effects of experimental soil disturbance on re-vegetation by natives and exotics in coastal Californian meadows. *Journal of Applied Ecology* 34: 631-644.
- Levine J.M. (2000) Species diversity and biological invasions: relating local process to community patterns, *Science* 288, p. 852-854.
- Moisuc A. and Dukič D. (2002) *Cultura plantelor furajere*. Editura Orizonturi Universitare, Timișoara, p. 16-21.
- Moisuc A. Breazu L. and Samfira I. (1995) *Lucrări practice, Cultura pajiștilor și a plantelor furajere*, Lito IAT, Timișoara.
- O'Mahony T (2003) The *Rosa tomentosa* group (Downey-roses) in Ireland, *Irish Botanical News*, nr. 13, martie 2003, p. 8-15.
- Planty-Tabacchi A. Tabacchi E. Naiman R.J. DeFerrari C. and DeCamps H. (1996) Invasibility of species rich-communities in riparian zones, *Conservation Biology* 10, p. 598-607.
- Sărățeanu Veronica and Moisuc A. (2004) Identification of some herbaceous invasive plant species in Banat's grasslands, *Lucrări Științifice Facultatea de Agricultură*, vol. XXXVI, Editura Eurobit Timișoara, 171-176.
- Stanton J.M. (2001) Galton, Pearson, and the Peas: A Brief History of Linear Regression for Statistics Instructors, *Journal of Statistics Education*, vol. 9, nr. 3.
- Sutherland W.J. (1997) *Ecological census techniques a handbook*, Cambridge: Cambridge University Press. 336p.

# The biodiversity and agronomic value of mountain permanent grasslands from the North-Eastern part of Romania

Vintu V., Samuil C., Iacob T., Postolache St. and Popovici I. C.

*University of Agricultural Sciences and Veterinary Medicine Iasi, Romania*

## Abstract

Over 4.9 million ha are covered by grasslands at national level and 676.7 thousands ha are situated in NE Moldavia, representing about 13.8% of the total national pastoral area. The agronomic value of the most important grassland ecosystems from NE Romania is generally low, because of improper floristic composition and structure. This is the result of a lack of management and improvement works, and of unreasonable utilization. The aim of this study was to identify, by geo-botanic methods, the floristic structure and the composition of the present vegetal canopy. The pastoral value and the grazing capacity were assessed for establishing a proper management and improvement measures, adapted to plot conditions. There are two important plant communities. One is dominated by *Festuca rubra* and *Agrostis capillaris*; its pastoral value is ranging between 2.0 and 2.5, its grazing capacity between 1.0 and 1.2 LU/ha. The second community is dominated by *Nardus stricta*; it has a low pastoral value and a grazing capacity below 1.0 LU/ha.

Keywords: biodiversity, grassland, pastoral value

## Introduction

Biodiversity conservation in grassland is an important concern because of the negative impact of several techniques and practices of modern agriculture. Intensive farming can dramatically decrease the number of grassland species. In the last decades, increasing the production has often been more important than the quality of the products and of the environment. The experience of the developed countries underlines the fact that taking decisions for the conservation of biodiversity must be made after interdisciplinary studies for developing a sustainable management of natural resources, among which permanent grasslands occupy an important place (Knops J.M.H. *et al.*, 2001; Lambers J.H.R. *et al.*, 2004; Sanderson M.A. *et al.*, 2004; Tilman D., Reich P.B. *et al.*, 2001).

In the last 40 years, grassland vegetation in Romania has changed a lot, which requires the update of previous studies as soon as possible, in order to have a clear picture of the present Romanian grassland composition. The *vegetation composition* and the *specific quality indicator* of the vegetation must also be characterized in order to measure the agronomical value of the grassland.

## Materials and methods

For determining the vegetation we have used the geo-botanical method (Braun-Blanquet, 1964), the analysis of the biodiversity being realized through *vegetation relevés* studies, conducted on two sites from the woodland zone, Pojorâta – Câmpulung Moldovenesc Valley and Coșna- Dornelor Waterflow Area (ten relevés). The ecological characteristics of these two sites show relatively low annual average temperatures and rainfall (Table 1).

An agronomical appreciation of the experimental plots was made on the basis of their pastoral value ( $V_p$ ) and their grazing capacity ( $C_p$ ).

The species from the relevés were clustered in the following groups: *dominant species* (60-100% cover), *codominant species* (25-40% cover) and *indicator species* (low abundance species, but giving information on some ecological factors).

Table 1. Ecological characteristics of the studied locations.

Vegetation belt	Location	Average annual temperature ( $^{\circ}\text{C}$ )	Average annual rainfall (mm)	Average altitude (m)	Soil types
<i>Fagus sylvatica</i> belt	Pojorâta - Câmpulung Moldovenesc	6.5	709	707	Eu-mezobasic brown
<i>Picea excelsa</i> belt	Coşna - Dornelor Waterflow Area	6.3	675	775	Podzol

The **Pastoral value** ( $V_p$ ) is influenced by the vegetation composition and by the fodder value of the component species. It is the main indicator for evaluating the grassland value. The contribution of each species to the *vegetation composition* was expressed through *specific covering* ( $A\%$ ). The fodder value of the component species was expressed through *specific quality indicator* ( $I_s$ ) with values between 0-5.

We calculated  $V_p$  by the following equation:  $V_p = \Sigma (A \times I_s/100)$

Grassland species were classically classified in three groups: grasses, legumes and miscellaneous.

The **grazing capacity** ( $C_p$ ) represents the livestock unit number, which can be distributed to the area of one grassland hectare, in relationship with their yield.

The **livestock unit** ( $LU$ ) is the standard animal unit used to aggregate the number of animals from different species or categories, equivalent to a cow of 600 kg weight, which produces 3000 litres of milk per year.

We calculated  $C_p$  by the following equation:  $C_p = V_p \times c$  (LU/ha)

“ $c$ ” is a coefficient with values between 0.4-0.6 which indicates the livestock unit number at one unit of the pastoral value, deeming that on a good permanent grassland from the temperate region, with  $V_p=5$ , the grazing capacity is of 2-3 LU/ha (Barbulescu C. and Motca Gh., 1987).

**AD** represents the estimation of the abundance and dominance, using the Braun-Blanquet scale with six degrees, between + and 5.

The **classification mark** represents a synthesis estimation of the grassland vegetation consulting three criteria: pastoral value, humidity criterion and yield, with the value between 0-100 (91-100=excellent grassland, class I,  $C_p>1.8$  LU/ha; 81-90=very good grassland, class II,  $C_p=1.6-1.8$  LU/ha; until 0-10= improper grassland for grazing, class X,  $C_p<0.2$  LU/ha) (Barbulescu C. *et al.*, 1980). There is a negative correlation between the grazing capacity and the grassland class quality.

## Results and Discussion

In Pojorâta - Câmpulung Moldovenesc Valley, grasslands contain 40 plant species, which is relatively high (Table 2). The average cover of the sward is 74%, grasses cover 58.5%; *Agrostis capillaris* (37.5%) and *Festuca rubra* (6.0%) are the most abundant species. All legume species cover together 7.5%, of which *Trifolium repens* is the most widespread (5.0%). A group of 26 miscellaneous species cover 8%.

Table 2. Grassland location: Pojorâta; Grassland type: *Agrostis capillaris*+*Festuca rubra* community.

No.	Species	Total cover: 74%				No.	Species	Total cover: 74%			
		Mark AD	A (%)	IS	AxIS			Mark AD	A (%)	IS	AxIS
<i>Poaceae</i> (58.5%)					Miscellaneous (continuation)						
1	<i>Anthoxanthum odoratum</i>	1	4.5	1	4.5	20	<i>Carex tomentosa</i>	+	0.5	0	0
2	<i>Arrhenatherum elatius</i>	1	5	4	20	21	<i>Centaurea jacea</i>	*		0	0
3	<i>Agrostis capillaris</i>	3	37.5	3	112.5	22	<i>Colchicum autumnale</i>	*		0	0
4	<i>Dactylis glomerata</i>	1	5.0	5	25	23	<i>Cruciata glabra</i>	+	0.5	0	0
5	<i>Brachypodium pinnatum</i>	*		1	0	24	<i>Galium verum</i>	*		0	0
6	<i>Cynosurus cristatus</i>	*		3	0	25	<i>Hieracium pilosella</i>	*		0	0
7	<i>Festuca rubra</i>	1	6.0	3	18	26	<i>Hypericum perforatum</i>	+	0.5	0	0
8	<i>Nardus stricta</i>	+	0.5	0	0	27	<i>Leucanthemum vulgare</i>	*		1	0
<i>Fabaceae</i> (7.5 %)					28	<i>Leontodon hispidus</i>	*		1	0	
9	<i>Lotus corniculatus</i>	+	0.5	4	2	29	<i>Luzula multiflora</i>	*		0	0
10	<i>Trifolium pratense</i>	1	5.0	4	20	30	<i>Pimpinella saxifraga</i>	+	0.5	1	0.5
11	<i>Anthylis vulneraria</i>	+	0.5	2	1	31	<i>Plantago lanceolata</i>	+	0.5	2	1
12	<i>Trifolium repens</i>	+	0.5	4	2	32	<i>Plantago media</i>	+	0.5	1	0.5
13	<i>Trifolium montanum</i>	+	0.5	3	1.5	33	<i>Polygala vulgaris</i>	*		0	0
14	<i>Cytisus ciliatus</i>	+	0.5	0	0	34	<i>Potentilla aurea</i>	+	0.5	0	0
Miscellaneous (8%)					35	<i>Primula veris</i>	+	0.5	0	0	
15	<i>Achillea millefolium</i>	+	0.5	2	1	36	<i>Ranunculus polyanthemus</i>	+	0.5	0	0
16	<i>Achillea stricta</i>	+	0.5	2	1	37	<i>Rumex acetosa</i>	+	0.5	0	0
17	<i>Alchemilla xanthochlora</i>	+	0.5	2	1	38	<i>Taraxacum officinale</i>	+	0.5	2	1
18	<i>Cardamine pratensis</i>	*		0	0	39	<i>Thlaspi kovatsii</i>	+	0.5		0
19	<i>Cardaminopsis halleri</i>	*		0	0	40	<i>Thymus pulegioides</i>	+	0.5	0	0
TOTAL: $\Sigma A = 74\%$ ; $\Sigma(A \times Is) = 211.5$											

In Coşna - Dornelor Waterflow Area, grasslands also contain 40 plant species (Table 3). The total cover of the sward is 97%, grasses reaching 64%. These grasslands are dominated by *Nardus stricta* (62.5%). Legumes have a very low participation in the sward, only 0.5%, while the miscellaneous plant group owns a number of 31 species with a cover of 32.5%.

Table 3. Grassland location: Coşna; Grassland type: *Nardus stricta*.

No.	Species	Total cover: 74%				No.	Species	Total cover: 74%			
		Mark AD	A (%)	Is	AxIs			Mark AD	A (%)	Is	AxIs
<i>Poaceae</i> (64%)					Miscellaneous (continuation)						
1	<i>Anthoxanthum odoratum</i>	1	5.0	1	5	20	<i>Centaurea jacea</i>	*		0	0
2	<i>Cynosurus cristatus</i>	+	0.5	3	1.5	21	<i>Cerastium semidecandrum</i>	+	0.5	0	0
3	<i>Holcus lanatus</i>	+	0.5	2	1	22	<i>Cruciata glabra</i>	*		0	0
4	<i>Alopecurus pratensis</i>	*		4	0	23	<i>Dactylorhiza maculata</i>	+	0.5	0	0
5	<i>Dactylis glomerata</i>	*		5	0	24	<i>Filipendula ulmaria</i>	+	0.5	0	0
6	<i>Festuca rubra</i>	*		3	0	25	<i>Hieracium bauhinia</i>	*		0	0
7	<i>Nardus stricta</i>	4	62.5	0	0	26	<i>Juncus inflexus</i>	+	0.5	0	0
<i>Fabaceae</i> (0.5 %)					27	<i>Knautia arvensis</i>	*		0	0	
8	<i>Trifolium repens</i>	+	0.5	4	2	28	<i>Leucanthemum vulgare</i>	*		1	0
9	<i>Trifolium pratense</i>	*		4	0	29	<i>Lychnis flos-cuculi</i>	+	0.5	0	0
Miscellaneous (32.5%)					30	<i>Luzula multiflora</i>	1		0	0	
10	<i>Alchemilla xanthochlora</i>	1	5.0	2	10	31	<i>Myosotis alpestris</i>	+	5.0	0	0
11	<i>Plantago lanceolata</i>	1	5.0	2	10	32	<i>Peucedanum spp.</i>	+	0.5	0	0
12	<i>Achillea millefolium</i>	+	0.5	2	1	33	<i>Plantago media</i>	*		1	0
13	<i>Carum carvi</i>	+	0.5	2	1	34	<i>Potentilla aurea</i>	+	0.5	0	0
14	<i>Leontodon hispidus</i>	+	0.5	1	0.5	35	<i>Ranunculus acris</i>	+	0.5	0	0
15	<i>Bellis perennis</i>	*		1	0	36	<i>Ranunculus auricomus</i>	+	0.5	0	0
16	<i>Cardamine pratensis</i>	+	0.5	0	0	37	<i>Rumex acetosa</i>	*		0	0
17	<i>Cardaminopsis halleri</i>	*		0	0	38	<i>Rumex obtusifolius</i>	*		0	0
18	<i>Carex elongata</i>	+	0.5	0	0	39	<i>Valeriana simplicifolia</i>	+	0.5	0	0
19	<i>Carex nigra</i>	1	5.0	0	0	40	<i>Veronica arvensis</i>	+	0.5	0	0

In the site Pojorâta – Campulung Moldovenesc Valley, the pastoral value is average ( $V_p=2.11$ , class V) and of the grazing capacity can reach 1.01 – 1.2 LU/ha (Table 4). In Coşna – Dornelor Waterflow Area, the pastoral value is very low ( $V_p=0.32$ , class X) and the grazing capacity must be lower than 0.21 LU/ha.

Table 4. Pastoral value of the two sites.

Location	Grassland type	Cover A%	AxIs	Vp	Cp LU/ha	Classification mark	Grassland class and category
Campulung Moldovenesc-Pojorâta	<i>Agrostis capillaris</i> + <i>Festuca rubra</i>	74	211.5	2.11	1.01-1.2	41-60	V-VI Average-low
Dornelor Waterflow Area - Coşna	<i>Nardus stricta</i>	97	32	0.32	<0.21	1-20	IX-X Degraded-improper

## Conclusions

The biodiversity of the two grassland types is high, the number of plant species being relatively high (40 species). The community type of *Agrostis capillaris*-*Festuca rubra* is a valuable one, the dominant species having a high fodder value, even if the production is not impressive. The community type of *Nardus stricta* has a low agronomical value, because of the low fodder value of the dominant species.

Used only for grazing by a great number of animals, with the sheeps and cow, some mountainous grasslands with acid and poor soils, have been degraded for over 40-50 years; *Nardus stricta* species was prevalent on these grasslands.

*Nardus stricta* grassland from *Picea excelsa* belt is used for grazing during 25-31 May and 20-30 September.

*Agrostis capillaris* + *Festuca rubra* grassland from *Fagus sylvatica* belt has a mixed utilization: it is mowed until the end of July and, then, grazed, in September, until 1-10 October.

Nowadays, the pressure of animals (grazing capacity) on certain grasslands diminished, but the grassland management was not improved.

These grasslands may be improved by manure fertilization and reasonable utilization, and sometimes by overseeding, applying a proper management.

## References

- Barbulescu C. and Motca Gh. (1987) Pajistile de deal din Romania. Editura Ceres. Bucuresti.
- Barbulescu C. (1980) Determinator pentru flora pajistilor cu elemente de tehnologie. Editura Ceres. Bucuresti.
- Braun-Blanquet (1964) Pflanzensoziologie, Grundzüge der Vegetationskunde. Springer-Verlag. Wien-New York.
- Knops J.M.H., K.L. Bradley and D.A. Wedin (2002) Mechanisms of species impacts on ecosystem nitrogen cycling. *Ecology Letters* 5: 454-466.
- Lambers J.H.R., W.S. Harpole, D. Tilman, J. Knops and P.B. Reich (2004) Mechanisms responsible for the positive diversity-productivity relationship in Minnesota grasslands. *Ecology Letters*, 7, 661-668.
- Sanderson M.A. and Goslee S.C. (2005) Plant diversity in pastures: management implications. In: Proceedings of the Appalachian Grazing Conference. March 22-24, 2005, Morgantown, West Virginia.
- Tilman D., P. B. Reich, J. Knops, D. Wedin, T. Mielke and C. Lehman (2001) Diversity and productivity in a long-term grassland experiment. *Science* 294:843-845.

# Quality seed mixtures for permanent grassland and field forage growing in Austria

Krautzer B., Buchgraber, K. and Pötsch, E.M.

*Institute of Plant Production and Cultural Landscape, Federal Research and Education  
Centre Raumberg-Gumpenstein, A-8952 Irdning, Austria*

## Abstract

Austria's grasslands lie in very heterogeneous climatic and soil conditions. Their management, in respect of cutting frequency and purpose of use, therefore requires differentiated and adapted seed mixtures. Within the framework of the Austrian Grassland Federation (AGF), in recent years, a quality standard was established, under private law, – from the cultivation of forage plants to seed production for the composition of mixtures – for the development of regionally adapted quality mixtures for permanent and temporary grassland production. AGF seed mixtures can be produced by every interested company in Austria and offered to grassland farmers. Following a six-year observation period, the best varieties are combined into seed mixtures. This takes into consideration regional aspects (such as climate and soil), as well as differing cultivation systems. The seed must meet quality standards that surpass the seed law regulations. The results are quality mixtures recommended and checked by the AGF for grassland and forage growing. Comparative field tests and experience gained through years of practice with AGF seed mixtures have fostered a strong demand in recent years.

Keywords: permanent grassland, temporary grassland, quality seed mixtures

## Introduction

The production of forage of adapted quality is a prerequisite to improve economical performance of grassland based livestock farming systems. What is essential is to secure the establishment of a stable, enduring, harmonic, healthy, highly digestible, sorrel-free stand of plants adapted to the climate, soil and intended use. In over-sowed, re-sowed and new sowed grasslands the quality of the seed mixture is decisive for achieving these targets. In recent years intensive work was undertaken in Austria to define high-quality seed mixtures for permanent grassland and field forage growing. With entry into the EU, the legal situation for seed has changed. It had great effects on the seed market. The EU standards for seed quality compared to previous norms valid in Austria are significantly laxer. This can have negative consequences, especially in respect of sorrel content. From the experiences of the control points in Austria, it can be concluded that, undoubtedly, many of the varieties listed in the EU catalogue are not suitable for the climatic and cultivation conditions in Austria.

The ecologically and economically motivated concept of quality seed mixtures drawn up originally in Austria were targeted at making high-quality seed available to the farmer. It is a concept that is now carried on, further developed and improved by the Austrian Grassland Federation (AGF). The AGF is a non-profit association that offers a common platform for research, chambers of agriculture, farm economy and farmers, with the aim of promoting grassland management in Austria.

## Principles of the AGF seed mixtures quality certification

AGF recommendations manual ([www.oeag-gruenland.at](http://www.oeag-gruenland.at))

The result of the AGF's work in recent years is a comprehensive total concept, from the cultivation to the propagation and the control of seed to the definition of regionally adapted mixtures. This concept links the production of quality varieties for the alpine grassland region and the added value of these varieties of a controlled quality that clearly exceeds the stipulations of the EU standards. So the AGF, as a private association, furnishes recommended and controlled quality mixtures for permanent and temporary grassland sowing. These are made available to grassland farmers by all participating seed firms. A manual defines the criteria for the attainment and allocation of the AGF standard for seed mixtures, and is the basis of a quality norm under private law (Krautzer *et al.*, 2005).

### Criteria of the AGF quality mixtures

The following specific criteria of the AGF quality mixtures enable Austrian grassland farmers to find a suitable mixture to accommodate the diverse conditions met in the field:

#### *Seed quality*

The minimum requirements for AGF quality mixtures according to the new seed law for purity, germination capacity and "Other Seeds" have been replaced by the AGF norms under private law, which guarantee a significantly better seed quality (Table 1).

#### *Guaranteed lack of dock seeds*

Special value is placed on the lack of sorrel. Every firm producing mixtures certified by AGF must have the individual varieties, as well as the readymade mixtures controlled for the presence of sorrel. As, in the AGF norm, there is a zero tolerance for sorrel seed, (Table 1). Such guarantee for lack of sorrel seed in grassland mixtures, above all under the requirements of organic cultivation, is of prime importance.

Table 1: Comparison of EU seed quality standards to AGF standards of selected grasses and leguminosae related to germinative capacity (GC), tolerated number of dock seeds (TD) and sample size (SS)

Species	EU quality standard			AGF quality standard		
	GC	TD	SS	GC	TD	SS
<i>Dactylis glomerata</i>	80	5	30	80	0	100
<i>Lolium hybridum</i>	75	5	60	85	0	100
<i>Poa pratensis</i>	75	2	5	80	0	50
<i>Festuca pratensis</i>	80	5	50	85	0	100
<i>Phleum pratense</i>	80	5	10	85	0	50
<i>Trifolium repens</i>	80	10	20	85	0	50
<i>Trifolium pratense</i>	80	10	50	85	0	100

#### *Choice of varieties*

Variety tests carried out, over six years, by the Federal Office and Research Centre for Agriculture in Vienna and the HBLFA Raumberg-Gumpenstein, which are located throughout Austria, allow to identify the best varieties on the basis of their persistence, their resistance to diseases, their quality and their adapted growth behaviour. Only the best varieties are added to the "AGF list of varieties" and are used for mixtures with an AGF recommendation.

### *Mixture content*

A significant role is played by the characteristics of the varieties (winter hardiness, competitive resistance, growth behaviour, state of health and degree of performance) for use in the special mixtures adapted to location and purpose of use. The mixtures are defined according to their purpose of use and according to regional aspects (provincial suitability) to provide optimum recipes to meet *all* conditions. Additionally, AGF mixtures must contain a guaranteed minimum share of seed produced in Austria: for 15% to 30% according to mixture type.

### *Control*

Single components of AGF mixtures are subject to severe controls according to seed quality and lack of dock seeds as described above. The readymade mixtures are again controlled for composition in respect of the prescribed AGF recipes. A sample is then taken and tested for the lack of sorrel. The mixtures made according to the norms are released by AGF and must be labelled "Controlled and Recommended by the AGF".

A double-digit percentage of mixtures made commercially available are then controlled annually. In this way the maintenance of regulations is controlled. In field cultivation such mixtures are also used for practice-orientated tests (e.g. to control variety authenticity and to compare to standard mixtures).

### **Declaration, AGF recommendation**

Every AGF quality mixture must carry on the sack a label giving a mixture designation, a brief description, a list of the varieties included in the mixture and the amount (percent of weight) as well as the recommended sowing amounts. AGF mixtures must carry the declaration: "Controlled and Recommended by the AGF".

### **Seed market and commercial implementation of AGF seed mixtures**

An overview on the market shows an Austrian consumption of, in average, 7,500 tons during the recent years. Roughly estimated, the share of the seed for grassland is about 1,800 tons annually. This demand of seed was not only for temporary grasslands, which account for only 6% of the total grassland area, but mainly for (re-)sowing of permanent grassland to regenerate the sward. A grassland area of about 80,000 hectares is subject to over-sowing, re-sowing and new sowing annually in Austria. As much as 75% of the spectrum of varieties used in grassland management comes from abroad. Commercial cultivation firms in Austria have not been active for decades in the production of forage plants. Only the Federal Research and Education Centre Raumberg-Gumpenstein, which has set clear accents in this direction during the recent years, can be mentioned. Up to now, twelve different local varieties of grasses and leguminous plants are available on the Austrian seed market. These varieties are produced on an average production area of 1,100 hectares.

The aim of the concept behind the AGF mixtures is to produce persistent, stable, harmonic, healthy and highly digestible grassland swards. These characteristics have multiple effects on operating results: less expenditure for grassland renewing, care and weed control, a better suitability for silage production and a high nutritive value, would only be some of the positive effects. Extensive comparative tests undertaken, over four years, by the HBLFA Raumberg-Gumpenstein (Buchgraber and Gerl 2000), between conventional grassland mixtures and those certified by AGF, have confirmed these expectations. But clear results in favour of AGF mixtures were also obtained in several field tests in terms of dry matter production (Part I



1997). These better performances, in quantity and quality, are coupled to dense sward less susceptible to weed invasion.

## Conclusions

The AGF concept is meanwhile well established throughout Austria and farmers are convinced about the value of the 21 different AGF quality seed mixtures that are currently on the market. The total sales of AGF mixtures are around 900 - 1000 tons annually, produced by a differing number of 2-5 firms. This means that more than half of the total requirement of seed is covered by AGF quality mixtures for grassland renovation.

## References

- Buchgraber K. und Gerl S. (2000) Grünlandmischungen mit den richtigen Sorten. Österreichische Arbeitsgemeinschaft für Grünland and Futterbau, INFO 6/2000, HBLFA Raumberg-Gumpenstein, 16 S.
- Krautzer B. (1999) Gräser- and Leguminosenzüchtung für den Alpenraum. Bericht über die 50. Arbeitstagung 1999 der Vereinigung österreichischer Pflanzenzüchter, HBLFA Raumberg-Gumpenstein, A-8952 Irdning, 19-25.
- Krautzer B., Girsch L., Buchgraber K. und H. Luftensteiner H. (2005) Handbuch für ÖAG-Empfehlungen von ÖAG-kontrollierten Qualitätssaatgutmischungen für das Dauergrünland und den Feldfutterbau. Veröffentlichung der Österreichischen Arbeitsgemeinschaft für Grünland und Futterbau (ÖAG), Fachgruppe Saatgutproduktion und Züchtung von Futterpflanzen. BAL Gumpenstein, A-8952 Irdning, 1-37.
- Krautzer B. und Graiss W. (2006) Entwicklung und Organisation der Züchtung und Saatgutwirtschaft von Futterpflanzen in Österreich. In: Bericht 11. Alpenländisches Expertenforum zum Thema "Züchtung, Wertprüfung und Vermehrung von Futterpflanzen für die alpenländische Landwirtschaft", Kornberg/Feldbach bzw. HBLFA Raumberg-Gumpenstein vom 27.-29. Juni, 1-5.
- Partl C. (1997) Vergleich von Standard- und Qualitätsmischungen für das inneralpine Grünland. Bericht ALVA-Tagung „Zeitgemäße Landbewirtschaftung“, Arbeitsgemeinschaft Landwirtschaftlicher Versuchsanstalten in Österreich, Wien, 195-196.

# Simulation of grassland management when fodder is utilised by cattle and its environmental impacts in the Czech Republic

Kohoutek A.<sup>1</sup> and Pozdíšek J.<sup>2</sup>

<sup>1</sup>*Crop Research Institute, Prague 6 - Ruzyně, Research Station in Jevíčko, the Czech Republic*

<sup>2</sup>*Research Institute for Cattle Breeding, Ltd., Rapotín, the Czech Republic*

## Abstract

This study evaluated the impact of cutting frequency (two, three or four silage cuts per year) on the forage yield, quality and feeding value for cattle of permanent grasslands in the Czech Republic. Forage dry matter yield, averaged over 4 experimental sites decreases from 8.05 t ha<sup>-1</sup> to 6.42 t ha<sup>-1</sup> for the two-cuts to the four-cuts systems. Based on these yields of harvested forage, the number of cows in a herd necessary to convert the forage dry matter that is potentially harvested from the 500 000 ha of grassland available for the national dairy herd in the Czech Republic ranged between 382 000 cows in the treatment without grain and extensive grassland utilisation in a two-cuts system, 306 000 in a three-cuts system and 231 000 in a four-cuts system. The environmental impact of these alternatives was also evaluated.

Keywords: grasslands, fodder quality, cattle, farming system modelling

## Introduction

Permanent grasslands cover an area of 950 000 ha which make up 22.2% of the total agricultural land (4280 000 ha) in the Czech Republic. However, a decrease in the number of livestock from 1236 000 cows in 1990 to 570 000 cows in 2004 has resulted in the deterioration of grassland management and utilization.

The number of dairy and suckler cows in the Czech Republic is lower than in EU-15 countries where the number of dairy cows reached 20.58 million and number of suckler cows reached 11.95 million, or 36.7% of the total cattle population (Pflimlin and Todorov, 2003). In the Czech Republic the number of dairy cows was 477 000 in 2002 and the number of suckler cows was about 100 000, which was only 17.3% of the total cattle population (Kvapilík *et al.*, 2003). Currently, about 300 000 ha of grassland are used by suckling systems and 150 000 ha are not managed. Both of these land use classifications make up nearly 50% of the 950 000 ha of grassland (Pozdíšek, Kohoutek *et al.*, 2004).

A complicated situation arises especially in less favoured areas, where substitution of ruminant farming by another agrarian activity is impossible in practice (Harvieu, 2002). However, a decrease in the importance of forage dry matter yield and an improvement in the utilisation of forage produced can allow for an increase of grassland forage quality. For example, Gruber *et al.* (2000) reported that two, three and four cuts per year resulted in forage intakes of 10.4, 13.0 and 15.2 kg of dry matter (DM) cow<sup>-1</sup> day<sup>-1</sup>, respectively, and an increase in the intake of total feedstuffs. Production of the feedstuff in terms of milk production was 11.4, 17.2 and 23.0 kg of milk per cow<sup>-1</sup> day<sup>-1</sup> after 2, 3 and 4 cuts, respectively.

The aim of this study was to examine the effect of two, three and four silage cuts per year on the forage yield and quality of permanent grassland in the Czech Republic. A modelling approach was used to determine the size of a dairy cow herd, which includes young cattle, that is necessary to efficiently utilise the forage harvested from 500 000 ha of grassland under these different cutting managements.

## Materials and methods

The experiment was established in 2003 on permanent grassland at four sites of Jevíčko, Liberec, Rapotín and Zubří. The grassland vegetation at each site was classified as *Arrhenatherion*. At each site there was a factorial design of four levels of grassland utilisation intensity (I) and four levels of fertilisation (F) laid out in four replications of 10 m<sup>2</sup> plots. The levels of grassland utilisation intensity were four cutting regimes of four cuts per year (I<sub>1</sub>: 1<sup>st</sup> cut on May 15<sup>th</sup> and then at 45-day intervals), three cuts per year (I<sub>2</sub>: 1<sup>st</sup> cut between 16<sup>th</sup> and 31<sup>st</sup> May and then at 60-day intervals), two cuts per year (I<sub>3</sub>: 1<sup>st</sup> cut between 1<sup>st</sup> and 15<sup>th</sup> June and the second cut after 90 days) and one or two cuts per year (I<sub>4</sub>: 1<sup>st</sup> cut between 16<sup>th</sup> and 30<sup>th</sup> June with the second cut after 90 days). The four levels of fertilisation were no fertilisation (F<sub>0</sub>), 30 kg P and 60 kg K ha<sup>-1</sup> year<sup>-1</sup> (F<sub>PK</sub>), F<sub>PK</sub> plus 90 kg N ha<sup>-1</sup> year<sup>-1</sup> (F<sub>PKN90</sub>) and F<sub>PK</sub> plus 180 kg N ha<sup>-1</sup> year<sup>-1</sup> (F<sub>PKN180</sub>).

The three treatments of I<sub>1</sub>, I<sub>2</sub> and I<sub>3</sub> at F<sub>PKN90</sub> were selected for examination in this paper. The F<sub>PKN90</sub> level corresponded to a stocking rate of about 1 livestock unit (LU) ha<sup>-1</sup>. The mean results obtained in 2003 and 2004 from the four sites were used to calculate the size of the herd necessary to utilise the conserved forage (Kohoutek *et al.*, 2005). Voluntary intake (kg DM cow<sup>-1</sup>) of the forage obtained from the three cutting regimes, either with or without grain, was determined in a series of feeding studies (Gruber *et al.*, 2000). Simulations were performed using stock feeding charts (Sommer *et al.*, 1994) for dairy cows of 600 kg with a daily milk yield of 20 kg or an annual production of 6100 kg of fat corrected milk (FCM) yield. This is the current mean level of performance of dairy cows in the Czech Republic. Therefore, the variables determined were daily and annual milk production, annual forage DM intake, total consumption of grain, the size of the dairy herd necessary to utilise the forage harvested from grassland under the three cutting regimes. The quantity of “feedable DM” was estimated at 70% of the forage yield to account for losses during harvest, conservation and feeding.

## Results and discussion

Dry matter yields and forage quality are presented in Table 1. The simulated total annual intakes of forage from two, three and four cuts per year when fed without grain were 4.21, 4.79 and 5.56 t DM cow<sup>-1</sup> year<sup>-1</sup>, respectively. Forage intake decreased when grain was added to the diet, possibly due to substitution, but the trend was similar at 3.26, 3.99 and 4.48 t DM cow<sup>-1</sup> year<sup>-1</sup>, respectively.

The size of a dairy cow herd, which includes young cattle, that is necessary to efficiently utilise the forage harvested from 500 000 ha of grasslands under the three cutting regimes was estimated based on the forage yield and intake results (Table 1). The production of feedable DM was 2 818 000 t in a two-cuts system, 2 566 000 t in a three-cuts system and 2 247 000 t in a four-cuts system, which was 20% less than the two-cuts system. Therefore, the intensive level of utilisation decreased the total forage production from the grassland, which is a major issue of grassland management in the Czech Republic and Slovakia.

The size of a dairy cow herd necessary to utilise the feedable DM without grain ranged between 382 000 cows in the extensive two-cuts system and 231 000 cows in the four-cuts system (Table 1). On this basis, potential milk production per cow and per lactation ranged between 2340 and 5637 kg of FCM milk.

Table 1: Impact of grassland use intensity, reflected by the number of cuts per year, on the quantity and quality of forage production, forage voluntary intake (VI), milk and manure production and the herd size necessary to utilise 500 000 ha of grassland under each cutting regime.

Variables	Unit	Utilisation intensity (number of cuts per year)					
		Without grain			With grain (to achieve 20 kg of FCM milk cow <sup>-1</sup> day <sup>-1</sup> )		
		2	3	4	2	3	4
Dry matter yield	t ha <sup>-1</sup>	8.05	7.33	6.42	8.05	7.33	6.42
NEL concentration in forage dry matter	MJ kg <sup>-1</sup>	5.28	5.70	5.85	5.28	5.70	5.85
Nitrogen substances concentration in forage dry matter	g kg <sup>-1</sup>	127	164	181	127	164	181
Crude fiber concentration in forage dry matter	g kg <sup>-1</sup>	281	231	214	281	231	214
Voluntary intake (VI) of dry matter by a dairy cow (recalculated from Gruber, 2002)	kg 100 kg <sup>-1</sup> LW	1.99	2.33	2.76	1.47	1.89	2.17
Calculation of dry matter intake by a dairy cow weighing 600 kg	kg head <sup>-1</sup>	11.94	13.98	16.56	8.82	11.34	13.02
NEL intake through forage (dairy cow weighing 600 kg)	MJ head <sup>-1</sup> day <sup>-1</sup>	63.04	79.69	96.88	46.57	64.64	76.17
Grain dry matter intake (energy concentration 8 MJ NEL.kg <sup>-1</sup> DM)	kg head <sup>-1</sup> day <sup>-1</sup>	-	-	-	6.94	4.68	3.24
NEL intake through grain	MJ head <sup>-1</sup> day <sup>-1</sup>	-	-	-	55.48	37.41	25.88
Daily NEL intake by a dairy cow weighing 600 kg	MJ head <sup>-1</sup> day <sup>-1</sup>	63.04	79.69	96.88	102.05	102.05	102.05
Calculation of daily milk production from forage (NEL)	kg FCM head <sup>-1</sup> day <sup>-1</sup>	7.7	13.0	18.5	2.4	8.2	11.9
Daily milk production	kg FCM head <sup>-1</sup> day <sup>-1</sup>	7.7	13.0	18.5	20	20	20
Milk production, per lactation	kg FCM	2340	3962	5637	6100	6100	6100
Annual dry matter forage intake	t head <sup>-1</sup>	4.21	4.79	5.56	3.26	3.99	4.48
Potential dry matter production on 500 thousand ha of grasslands	Thousand t	4025	3665	3210	4025	3665	3210
Feedable dry matter production after deducting 30 % losses	Thousand t	2818	2566	2247	2818	2566	2247
Number of cattle in the cow herd	Thousand	382	306	231	494	368	286
Stocking rate of cattle per ha of grassland	LU ha <sup>-1</sup>	1.61	1.28	0.97	2.08	1.54	1.20
Slurry production	Thousand m <sup>3</sup>	15545	11992	9897	20071	14407	12276
N production in cattle slurry per ha of grassland	kg N ha <sup>-1</sup>	90.8	88.0	103.1	126.9	109.7	122.1

Therefore, the milk production from dairy cow herds that utilise grassland forage from two, three and four cuts per year would be 894, 1212 and 1302 000 t of milk per a year, respectively.

The addition of grain into the diet, in order to reach a mean milk yield of 20 kg FCM head<sup>-1</sup> day<sup>-1</sup>, led to an increase of 55-112 000 the cows necessary to convert the amount forage given. The consumption of grain required to reach a target yield of 6100 kg of FCM milk year<sup>-1</sup> was 1 045 000 t in a two-cuts system, 525 000 t in a three-cuts system and 283 000 t in a four-cuts system. The milk production from these modelled herds was 3 013 000, 2 245 000 and 1 745 000 t of FCM milk per year, respectively.

## Conclusion

It is possible that an extensive system of grassland utilisation can require more cattle management while an intensive system of grassland management can support a good level of milk production without a large quantity of imported feedstuffs. Based on the simulations a four-cuts system seemed to be optimal for the agricultural utilisation of 0.5 million ha of grasslands in the Czech Republic. This will require the development of a dairy cow herd of 250 – 300 000 which produces about 6000 kg of FCM milk per year, together with young cattle, to utilise the forage produced.

The system where grassland is cut four times per year is also the most favourable practice from an ecological perspective. It decreases the annual amount of grain imported onto the 500 000 ha of grassland by 762 000 t. This decreases the nutrient load of the agricultural system through the reduction of imported nutrients in the purchased feedstuff. Under such a system a stocking rate of 0.5 cow ha<sup>-1</sup> of grassland was reached and about 1 LU ha<sup>-1</sup> when young cattle were included, which is the herd size quota in the present agricultural situation.

## Acknowledgements

The contribution was financially supported by project VZ0002700601 and QF3018.

## References

- Gruber L., Steinwidder A., Guggenberger T., Schauer A., Häusler J., Steinweder R. and Steiner B. (2000) Einfluss der Grünlandbewirtschaftung auf Ertrag, Futterwert, Milchezeugung und Nährstoffausscheidung. In: *Bericht 27. Viewirtschaftliche Fachtagung*, BAL Gumpenstein 6.-8. 6. 2000, 41-88.
- Harvieu B. (2002) Multi-functionality: a conceptual framework for a new organisation of research and development on grasslands and livestock systems. In: *Multi-Function Grasslands (Quality Forages, Animal Products and Landscapes)* (Derand, J. L., Emile, J. C., Huyghe, Ch., Lemaire, G., eds.), La Rochelle, France, Imprimerie P. Oudin, Poitiers, 2002, p. 1 - 2.
- Kohoutek A., Pozdříšek J., Šrámek P., Odstrčilová V., Nerušil P., Komárek P., Gaisler J., Fiala J., Mičová P. and Grézlová M. (2005) Effects of intensity fertilisation and cutting frequency on yield and forage quality of grassland. In: *Integrating Efficient Grassland Farming and Biodiversity*, (Lillak, R., Viiralt, R., Linke, A. Geherman, V. eds.), Tartu, 2005, Estonsko, pp. 332-335.
- Kvapilík J., Pytloun J., Bucek P. a kol. (2003) Chov skotu v České republice, hlavní výsledky a ukazatele za rok 2002. ČMSCH, SCHČSS, SCHSČR, Praha, 2003, 111 pp.
- Pflimlin A. and Todorov N., A. (2003) Trends in European forage systems for meat and milk production: facts and new concerns. In: *Optimal Forage Systems for Animal Production and the Environment*. Bulgaria, Pleven. 2003. pp. 1 – 10.
- Pozdříšek J., Kohoutek A., Bjelka M. and Nerušil P. (2004) Utilization of grassland by suckler cow rearing (*in Czech*). Praha: ÚZPI, 2004, 103 pp.
- Sommer A., et al. (1994) Potřeba živin a tabulky výživné hodnoty krmiv pro přežvýkavce. ČAZ, komise výživy hospodářských zvířat, Pohořelice: 198 pp.

# Effects of days of regrowth and N fertilization on fatty acid composition of perennial ryegrass and CLA concentration in milk from stall-fed dairy cows

Smit H.J.<sup>1</sup>, Malda K.<sup>1,2</sup>, Dijkstra J.<sup>2</sup> and Elgersma A.<sup>1</sup>

<sup>1</sup>*Crop and Weed Ecology Group*

<sup>2</sup>*Animal Nutrition Group, Wageningen University, The Netherlands*

## Abstract

Grassland management could offer means to produce milk with naturally higher concentrations of unsaturated fatty acids (FA) such as conjugated linoleic acid (CLA). Regrowth stage and N fertilization affect the concentration of FA in grasses, which could affect milk FA. Four paddocks were split and received either 73 or 37 kg N ha<sup>-1</sup>; herbage was subsequently cut daily from 25 to 43 days of regrowth. Two groups of 18 cows were stall-fed during these 19 days with either high or low N fertilized grass. FA concentrations in the herbage and the CLA concentration in the milk were monitored.

The high N fertilized plots had a higher herbage mass, but there was no difference in herbage N or FA concentration. There was a negative effect of days of regrowth on the FA concentration in grass, which was associated with a lower CLA concentration in the milk. In general there was no effect of N treatment on milk CLA concentration. Only during the last two days of the experiment, when there was a very large difference in herbage mass between the N treatments (2000 vs. 4000 kg DM ha<sup>-1</sup>), the CLA concentration was significantly ( $P < 0.05$ ) higher in milk of cows fed grass from the low N treatment. This could be a result of the lower herbage yield and NDF content.

The lack of effect of N fertilizer treatment on milk FA composition may be due to the fact that treatments surprisingly did not differ in grass N content. During the final days, effects were confounded with changes in other chemical composition variables. The negative effect of grass regrowth stage on herbage FA and milk CLA concentration confirmed our hypotheses.

Keywords: conjugated linoleic acid, CLA, regrowth, nitrogen

## Introduction

There is an increasing acceptance that food can contribute to the prevention and development of some human disease conditions. Grassland management could offer means to produce milk with naturally higher concentrations of unsaturated fatty acids (FA) such as conjugated linoleic acids (CLA). The concentration of FA in herbage declined with the maturity of the plant and regrowth interval (Dewhurst *et al.*, 2003 Elgersma *et al.*, 2003), that could be partly explained by leaf/stem ratio evolution. Moreover, N fertilization has been shown to increase FA concentrations in ryegrass (Witkowska *et al.*, 2007). This experiment was set up to examine the effects of regrowth and N fertilization of stall-fed grass on milk FA concentration.

## Materials and methods

The experiment was carried out in Kubaard in the North of the Netherlands. Four paddocks, predominately *Lolium perenne*, were split in two plots that received either 73 or 37 kg N ha<sup>-1</sup>. Herbage was cut daily, from 25 to 43 days of regrowth. Two groups of 18 cows were stall-fed, *ad libitum*, with either high or low N fertilized grass. The experiment started on the 15<sup>th</sup> of June and continued until the 3<sup>rd</sup> of July. Cows received additional concentrate feed according to lactation stage, which was not different between the two groups.

From both plots, grass was sampled and sward surface height (SSH) was recorded. Grass samples were analyzed for bio-chemical composition, using NIRS and for FA concentration, using gas chromatography. Milk yield was recorded individually and milk samples were analyzed for protein, fat and CLA concentration using a rapid analysing technique (Elgersma and Wever, 2005).

Sward characteristics, chemical parameters were analyzed with the General Linear Model procedure (SPSS for Windows, Rel. 11.0 Chicago: SPSS Inc.), according to the following model:  $Y_{ij} = \mu + N_i + D_j + e_{ijk}$ . Where  $\mu$  is general mean;  $N_i$  is the N effect ( $i = \text{high or low}$ );  $D_j$  is day effect ( $j = 1.15$ );  $e_{ijk}$  is residual term. Interaction could not be measured, because of the statistical design. LSD test was used for all pair wise comparisons. Milk fat parameters were analyzed for the N effect using a one-way ANOVA on each day separately and over the whole period by averaging for each of the 36 cows the five measurement days.

## Results and discussion

The high N fertilized plots had a higher ( $P < 0.05$ ) SSH and herbage mass (difference on average 400 kg DM ha<sup>-1</sup>) than the low N fertilized plots. This difference increased during the experiment.

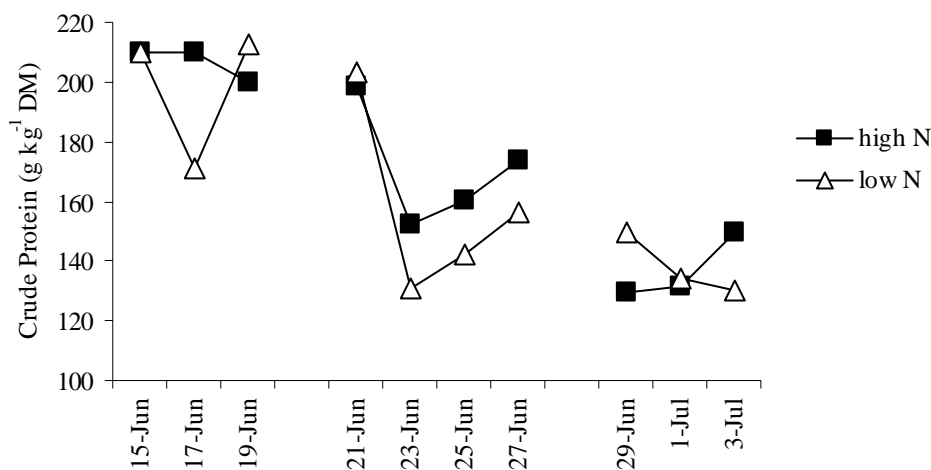

Figure 1. Crude protein concentration in grass fertilized with high or low N levels (gaps represent paddock changes)

As shown in Figure 1, there was no difference ( $P > 0.05$ ) in herbage protein content between both N treatments, but there was a negative trend in time explained by the increasing regrowth stage of the sward. The opposite trend is visible in the NDF concentration (Figure 2), showing an increasing NDF concentration in the progress of the experiment. In the last three days of the experiment the low N treatment had a lower NDF concentration than the high N treatment.

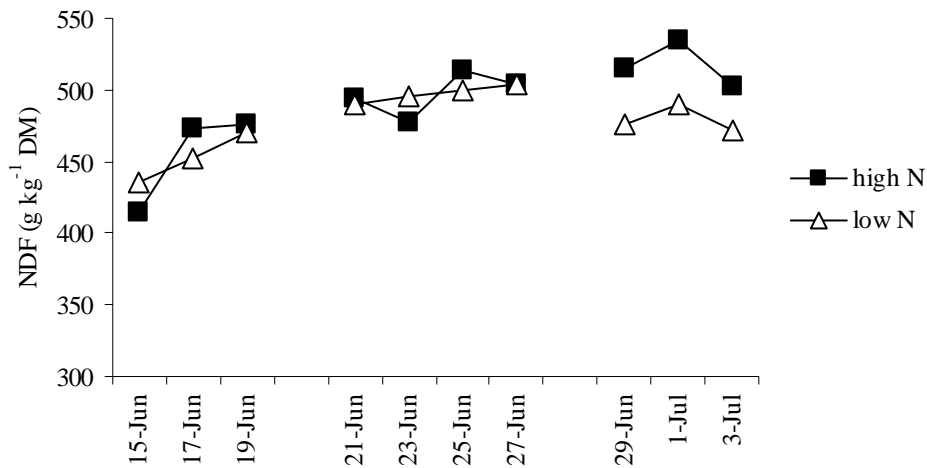

Figure 2. NDF concentration in grass fertilized with high or low N levels (gaps represent paddock changes).

The total FA concentration of the grass was not influenced ( $P > 0.05$ ) by N fertilization. However, there was a negative effect of days of regrowth on the FA concentration in grass in the low N treatment (Figure 3).

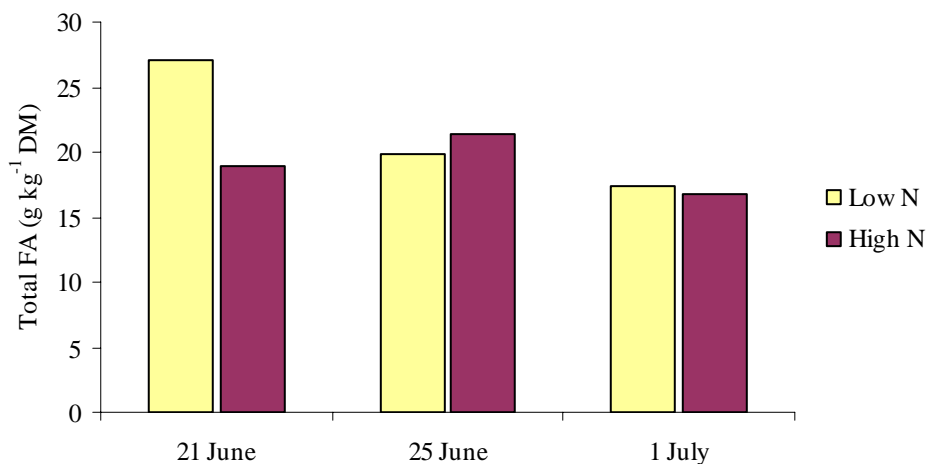

Figure 3. Total fatty acids (FA) concentration (in g kg⁻¹ DM) in grass fertilized with high or low N level on three sampling dates during the experiment.

A progressing regrowth stage was associated with a lower CLA concentration in milk fat as shown in Figure 4. In general there was no effect ( $P > 0.05$ ) of N treatment on milk fat CLA concentration. Only during the last two days of the experiment (1<sup>st</sup> and 3<sup>rd</sup> July), when there was a very large difference in herbage mass between the N treatments (2000 vs 4000 kg DM/ha), the CLA concentration was significantly ( $P < 0.05$ ) higher in milk of cows fed grass from the low N treatment. This could be a result of the lower NDF concentration during these days (Figure 2). The intake of low N grass might have been higher, because of a lower NDF-content (Taweel *et al.*, 2005), and therefore the intake of FA with grass might have been higher in this group. In addition, if there is more NDF in the diet, this will stimulate fibrolytic bacteria that enhance the final step of biohydrogenation in the rumen (Dewhurst *et al.*, 2003). This might explain the higher concentration of CLA in the milk.



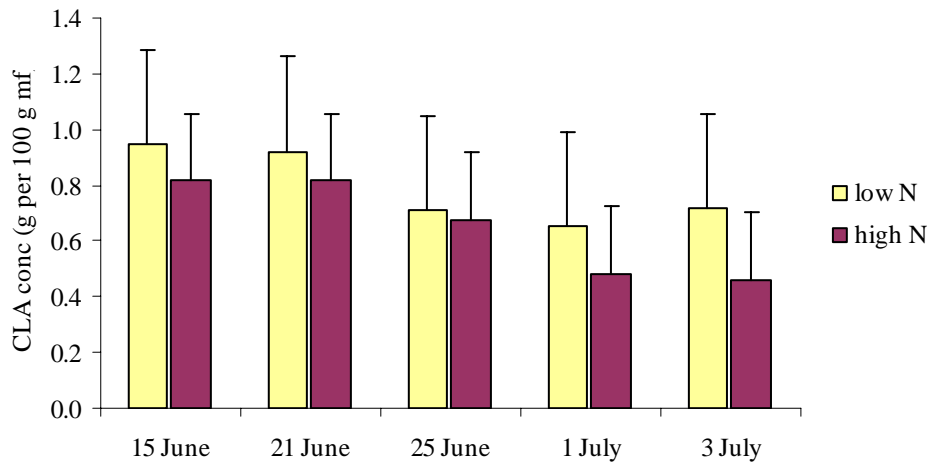

Figure 4. CLA concentration (g per 100 gram milk fat) of cows consuming a grass fertilized with high or low N, on five sampling dates during the experiment.

## Conclusion

The lack of effect of N fertilizer treatment on milk FA composition may have been due to the fact that treatments unexpectedly did not differ in grass N and FA concentration, and were confounded with changes in days of regrowth. The negative effect of grass regrowth stage on herbage FA and milk CLA concentrations confirmed our hypotheses.

## References

- Dewhurst R.J., Scollan N.D., Lee M.R.F., Ougham H.J. and Humphreys M.O. (2003) Forage breeding and management to increase the beneficial fatty acid content of ruminant products. *Proceedings of the Nutrition Society*, 62, 329-336.
- Elgersma A., Ellen G., Van Der Horst H., Muuse B.G., Boer H. and Tamminge S. (2003) Comparison of the fatty acid composition of fresh and ensiled perennial ryegrass, as affected by cultivar and regrowth period. *Animal Feed Science and Technology*, 28, 191-205.
- Elgersma A., and Wever A.C. (2005) Grazing fresh grass at a high herbage allowance results in milk with a higher CLA concentration than a maize silage diet. *Modern aspects of fats and oils*, Abstracts, 61.
- Taweel H.Z., Tas B.M., Smit H.J., Elgersma A., Dijkstra J. and Tamminge S.. 2005. Improving the quality of perennial ryegrass (*Lolium perenne* L.) for dairy cows by selecting for fast clearing and/or degradable neutral detergent fiber. *Livestock Production Science* 96: 239-248.
- Witkowska I.M., Wever A.C. and Elgersma A., (2007) Seasonal effects on fatty acid concentrations in perennial ryegrass (*Lolium perenne* L.) in relation to nitrogen and regrowth interval. *Agronomy Journal* (in press).

# **Green Futures for Grassland: a regional case study on farmer engagement to develop measures for improving environmental benefits on intensively managed grassland**

Hopkins A. and Lobley M.

*Centre for Rural Policy Research, University of Exeter, Exeter, EX4 6TL, UK*

## **Abstract**

Intensively managed grassland is usually a poor quality habitat and often contributes to a range of environmental problems. Raising environmental awareness and improving biodiversity value through agri-environmental schemes on such farms is a major challenge. The aims of this project were to stimulate and engage intensive livestock farmers in collaboration with environmentalists and other stakeholders in ways which recognized and emphasized their role in finding sustainable solutions. Through meetings with farmer groups in a dairy farming region (south-west England) management changes that farmers would be willing to undertake were discussed. Farmers were required to evaluate the financial and other implications that various measures might have for their farm business, and to identify barriers to adoption. Potential 'win-win' situations were considered that could improve biodiversity potential and produce agronomic benefits. The need for knowledge transfer to farmers on potential environmental measures and the provision of locally relevant demonstration sites emerged as important issues limiting adoption of environmental improvements.

Keywords: dairying, intensive grassland, biodiversity

## **Introduction**

This study was conducted in south-west England, a region having a proportion of agriculturally improved grassland. Agri-environmental schemes have been available since the late 1980s but have had little impact on the more intensively managed farms. Whilst some areas of grassland in the region are currently of national and international significance for biodiversity, most improved grassland is of limited value for nature but does have the potential to deliver improvements to the region's environment and biodiversity. The most recent agri-environment scheme, Environmental Stewardship (ES) (Defra, 2005), aims to see 75% of England's agricultural land brought into an 'Entry Level Stewardship' (ELS) agreement. If taken up widely, ES will contribute towards improved water quality and reduced soil erosion, improve conditions for wildlife on farms, and help maintain the character of the landscape and its historic environment. Attracting large numbers of farmers previously not involved in agri-environmental schemes (particularly dairy farms) will be a considerable challenge. Nevertheless, every farm in the region can provide some degree of environmental improvement: the challenge is to enable this to occur on farms that consist predominately of improved grassland. The specific objectives of the project were to: (1) raise awareness across the region of the environmental problems caused by the use and management of intensive grasslands; (2) explain the range of environmental benefits that sward diversification could provide; (3) identify the most promising management changes farmers might be willing to undertake to test emerging approaches; and (4) host a grassland 'summit' to share with key audiences the progress made by the project and explore future opportunities.

## Materials and methods

Given that the main objectives concerned awareness raising and dialogue with farmers, the project adopted a participative and flexible methodology based on engagement with farmer groups. Presentations were made to existing farmer discussion groups, local grassland society meetings, and to groups within an Objective 1 project (Grassland Challenge).

A 1-hour interactive presentation was devised which used a stepwise consideration of possible opportunities starting with actions that fit within farmers' terms of reference as good agricultural practice, such as improved nutrient use and introduction of grass-legume swards, followed by actions that were progressively more likely to lead to environmental improvements. This was followed by discussions in which the audience would give their reactions, make alternative suggestions and comment on their perceived implications. The next stage involved a 'bidding game' in which participating farmers made monetary bids indicating the minimum payment that would be necessary to induce them to enter land under specific management options, and to indicate how much land they would be willing to enter for this level of payment. The purpose was not to establish the 'price' of various options but, using the monetary and area bids as proxy indicators, to explore how willingness and resistance varied as the environmental benefits of the options increased. Presentations were made at five farmer meetings (43 farmers) and two further meetings were held with members of the policy community. The participating farmers were responsible for managing over 5000 ha, of which 38% were temporary grass and 38% permanent grass. They were predominately (64%) dairy farmers. These meetings were followed by a grassland summit attended by a wider range of grassland stakeholders (further information in Lobley and Hopkins (2006).

## Results and discussion

*Knowledge gaps.* Several issues were identified through the farmer meetings that suggested the need for additional and more effective knowledge transfer (KT). For instance, a clear knowledge gap emerged surrounding aspects of sward diversification. Many farmers with land suited to permanent pasture do not want to plough unnecessarily, which was a reasonable justification for not sowing red clover, but in other cases it appears that farmers are even unaware of potential agronomic (*let alone*, environmental) benefits of legume-based systems. One specific knowledge barrier is related to bloat risk in legume-based systems. There was a lack of understanding about bloat and how to manage to prevent or reduce the risk.

The issue of nutrient budgeting also highlighted a recurrent knowledge gap about how soil analyses could be interpreted in terms of the nutrient contents of fertilizers and farm manures. Although some farmers thought that they did this to some extent, e.g. applications of P and K based on soil analysis, it seemed clear that the concepts of nutrient audits were not really appreciated. Consequently, there is a knowledge gap which is preventing nutrient budgeting from being incorporated into farm decision making and this has implications for delivery of environmental outcomes. Farmers suggested a need for demonstration sites that were meaningful in terms that related to the environment of their own farm, such as soil type, with a more localised network of demonstration farms/sites.

*Incentive payments.* In addition to various KT needs, farmers pointed to the need for financial incentives. In terms of the land and monetary bids made by farmers, options and actions to increase white clover and to vary sward height emerged as the most popular. Increasing the use of clover and other legumes is not currently an option within agri-environmental schemes and yet was the most favoured option identified through this project. Clearly, it would only provide limited biodiversity gains but could nevertheless represent an entry level option for otherwise intensively managed farms. The next most favoured option was varying sward

height, recognised as leading to sward structural changes that can affect invertebrates and foraging by birds. Beyond this, intensive grassland farmers are less willing (requiring higher payments and offering small areas of land) to implement demanding management practices.

*Capital support.* Farmers also identified a need for capital support to bring about environmental improvements. Some suggestions pose challenges to the 'Polluter Pays' Principle, e.g. farmers identified improved slurry storage to avoid having to spread at inappropriate times or on unsuitable sites. Other suggestions, such as capital support towards the cost of temporary fencing of sensitive areas and hedgerow restoration, are currently only available through the more demanding higher level Environmental Stewardship.

*Principles and characteristics of a green future for grassland.* The outputs of the farmer discussion groups clearly point to some potential for intensive grassland farmers to adopt practices which would produce some environmental gain. In all of this it is important to recognise that one of the unique features of dairy farming is the tightness of the margin on milk price and the effect that a very small decline in milk yield, or increase in production costs or fall in milk price has on turning a herd that is in profit to one that is operating at a loss. Any changes in grazing management are affected by concerns of losing milk yield, problems with access to distant fields, cold and wet weather in spring and autumn. Dairy farmers that rely heavily on ryegrass silage and purchased feed may continue to do so because of perceived simplicity compared with growing, say, legume silage crops.

It was clear from the discussions with farming and non-farming stakeholders throughout this project that there is an opportunity to advocate a realistic environmental land management package that fits intensive grassland farming and meets the challenge of improved environmental delivery. This would include support needs broader than, but building on the existing opportunity that the current agri-environmental measures provide. At the same time, environmentalists must have realistic expectations about short-term achievements.

If intensive grassland farmers are going to make a contribution to environmental improvement they need to be informed and persuaded of the implications for their business. This will involve incrementalism – a gradual stepwise movement rather than a rapid movement. The environmental pay-off may primarily derive from the potential scale effects from the large areas of land that could be involved rather than from a significant short-term reorientation of land management practices.

*The Grassland Summit.* Two principles emerged equally strongly from the grassland summit: farmer stakeholders must be involved in the design of any initiatives which derive from this work, and they must have a sense of ownership and be willing and able to act as advocates. If this is not achieved then the sense of social acceptability that was identified as so important may also fail to materialise. In addition, any practical policy intervention must be at an appropriately local scale in order to make it meaningful for participants.

A full list of recommendations is given in Table 1. The first recommendation of the research team is that consideration of an 'intensive-grassland-proofing' exercise be undertaken to discover the extent to which existing and planned initiatives are consistent with the requirements of intensive grassland farming and identify any steps needed to make them more so: i.e. are there any changes that could be made to policy initiatives that would make particular management options, training events, etc more relevant and more appealing to intensive grassland farmers?

Awareness was identified as a necessary precursor to more ambitious initiatives, ranging from 'simple' awareness-raising activities through to detailed and specific KT activities, e.g. regarding the establishment and management of legume-based swards, or multi-species sown grass swards. There is a need for a localised demonstration network within easy access of most potential users. In this context a one-hour drive was considered acceptable.

Table 1. Recommendations of the research team

- 
- Intensive grassland-proofing exercise
  - Knowledge transfer (KT) and awareness raising programme targeted at intensive grassland farmers
  - Localised demonstration network
  - Geographically targeted initiatives with significant degree of farmer design
  - Promote mixture of existing, modified and new Environmental Stewardship options
  - Any grant aid conditional on attendance at KT events
  - Improved evidence base for policy-making and delivery: field survey of intensive grassland farms – current environmental services and future potential.
  - Research to inform strategic thinking on trends in grassland in the region and implications for delivering environmental outcomes
  - Greater demonstration role for large landowners and public bodies.
- 

The project was conducted at a regional level but the results have a wider geographical relevance. There is a need to understand why there is resistance by some farmers to adopting improved environmental management: are environmental actions considered likely to be unaffordable, or a cultural issue, or a fear of change? There is also a need to think ahead to consider strategic issues concerning the type and structure of agricultural activity required to underpin the environment and how to deal with challenges such as further CAP reform. The effects of the possible shrinking of the Single Payment Scheme budget and its impact on farm businesses (post-2012) are potentially very significant. The survival of small and medium scale family farms, especially dairy farms, is not assured. The potential situation that the trend towards a smaller number of ‘mega-herds’ of highly capitalised and highly productive farms serving the commodity milk market is one scenario. Farmers, who at present see little scope for a ‘greener’ system of dairy farming at the current family-farm scale, need to consider whether they are likely to have a future that is not part of a multi-functional system.

## Conclusions

Outputs of the farmer discussion groups showed a potential for intensive grassland farmers to adopt practices leading to environmental gains. Lack of knowledge by farmers about ‘greener’ farming practices is a barrier to adoption of measures such as improved nutrient management and encouraging increased biodiversity. Demonstration sites that were relevant to particular farm conditions could help meet this knowledge gap. For researchers and policy makers it is important to discover the extent to which existing and planned initiatives are consistent with the requirements of intensive grassland farming and identify any steps needed to make them more so. Management options, training events, etc need to be relevant and appealing to intensive grassland farmers if these farmers are to adopt environmental measures within the context of intensive farming.

## References

- Defra (2005) Entry Level Stewardship Handbook. London: Department of Environment, Food and Rural Affairs. On-line version. <http://www.defra.gov.uk/erdp/schemes/els/handbook/default.htm>
- Lobley M and Hopkins A. (2006) *Green Futures: practical environmental enhancements in the South West’s improved grasslands*. CRR Research Report no. 19. Exeter: University of Exeter Centre for Rural Research, 52 pp.

# Effects of different periods of abandonment on the features of the class *Festuco-Brometea* Br.-Bl. meadows in N-E Italy

Da Ronch F., Macolino S. and Ziliotto U.

University of Padova, Department of Environmental Agronomy and Crop Productions –  
Agripolis- Viale dell'Università 16, 35020 Legnaro (PD) Italy

## Abstract

Since the end of the years 1960, the pressure of agricultural activities and livestock husbandry in the Italian mountains has decreased. Consequently, important vegetation changes have affected grasslands endangering their conservation.

With the aim to define the effect of abandonment on the evolution of grasslands, five permanent meadows in the Venetian Prealps were studied. Meadows were different for the abandonment period, but they were similar for climate, soil, botanical composition and past management.

Floristic composition was studied by the Braun-Blanquet procedure, and soil samples were collected to determine litter thickness. According to the phytosociological analysis, all meadows belong to the class *Festuco-Brometea* Br.-Bl.

The most evident effect the abandonment was the reduction of species number, followed by a marked increase of monocotyledone species and especially *Brachypodium rupestre* (Host) R. et S. ssp. *caespitosum* (Host) Sch.

Keywords: *Festuco-Brometea*, grassland abandonment, *Brachypodium rupestre*, Venetian Prealps

## Introduction

The reduction of anthropic activities in marginal Alpine areas is at the origin of the establishment of vegetation communities with low landscape and usage value.

In Italy, this process often occurs in native and semi-natural grasslands of the class *Festuco-Brometea* Br.-Bl. Mountain depopulation, difficult mechanization and lower profitability compared to agricultural activities in plain areas are the major reasons of this abandonment. In the study area, agriculture still has a very important role, because it is located inside the DOC zone of the Prosecco of Conegliano and Valdobbiadene. Consequently a lot of farmers become more and more specialized in vineyard cultivation while forage productions decrease as years go.

In this work, some features of five close meadows abandoned in different periods were compared.

## Materials and methods

The present work concerns oligotrophic meadows located between 350 and 550 m a.s.l in the southern side of Prealpi Trevigiane (the border between Treviso and Belluno provinces). Meadows are characterised by southern exposition and a steep slope that ranges from 20 to 40%. The underlying rock is calcareous and the main soil types in the area are Eutricambisols and Redzicleptosols. The study area is characterised by a mean yearly temperature of 12.5°C and an annual rainfall of 1502 mm distributed with a sub-equinoctial trend with two peaks: one in April (169.8 mm) and a second in November (155.5 mm). Meadows were chosen

according to their period of abandonment that goes back respectively to 3, 10, 15, 20 and 25 years. On these meadows, during the season 2006, botanical surveys using the Braun-Blanquet method were performed, and coverage percentage of every species was recorded. Litter thickness of each meadow was also recorded. The botanical surveys were submitted to multivariate analysis, using the Mulva 5 program, adopting the complete linkage algorithm and the Van der Maarel correlation coefficient. Several simple linear regressions were also made to estimate the relationship between 'abandonment period' and the following variables: 'number of species', 'number of monocotyledon species', 'number of dicotyledon species', 'cover percentage of monocotyledon species' 'cover percentage of *Brachypodium caespitosum*', 'Shannon Index' and 'litter thickness'.

## Results and discussion

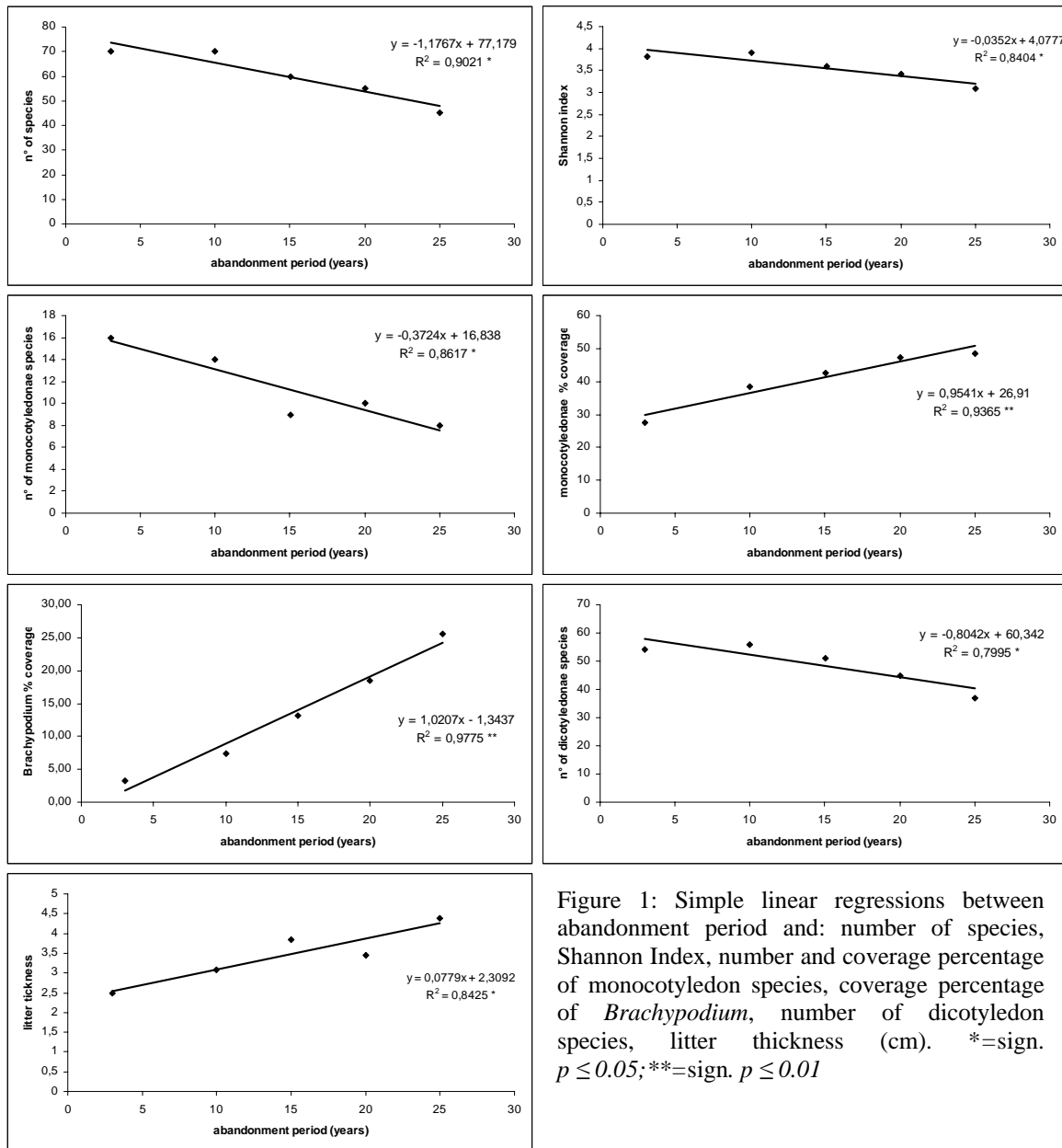

Figure 1: Simple linear regressions between abandonment period and: number of species, Shannon Index, number and coverage percentage of monocotyledon species, coverage percentage of *Brachypodium*, number of dicotyledon species, litter thickness (cm). \* = sign.  $p \leq 0.05$ ; \*\* = sign.  $p \leq 0.01$

Table 1: Result of the cluster analysis and phytosociological Table

Abandonment period (years)	25	20	15	3	10
Survey number	2	1	3	4	5
<b>Character and differential species of the alliance Mesobromion Br.-Bl. et Moor 38</b>					
Scabiosa columbaria L.	0,64	1,28	1,32	1,36	2,36
Ononis repens L., 4: 0,27; Carlina acaulis L., 5: 0,21					
<b>Character species of the order Brometalia erecti Br.-Bl. 36</b>					
Bromus erectus Hudson	7,63	11,12	5,95	10,40	3,46
Helianthemum nummularium (L.) Miller ssp. obscurum (Celak.) Holub	1,27			0,82	0,43
Hippocrepis comosa L.		0,37		0,82	1,29
Arabis hirsuta (L.) Scop.	0,13	0,32		0,82	
Teucrium chamaedrys L.		1,59		3,01	5,81
Koeleria pyramidata (Lam.) Domin, 4: 1,64 - 5: 4,52; Dianthus carthusianorum L. ssp. carthusianorum, 1:					
<b>Character and differential species of the class Festuco-Brometea Br.-Bl. et Tx. 43</b>					
Thymus praecox Opiz	1,91	0,97	2,62	1,37	1,49
Salvia pratensis L.	1,60	2,55	2,30	1,09	1,06
Brachypodium rupestre (Host) R. et S.	25,50	18,53	13,18	7,39	3,21
Galium verum L.	1,91	0,97	1,32	1,37	1,71
Sanguisorba minor Scop. ssp. minor		0,64	1,64	2,46	3,43
Euphorbia cyparissias L.	2,22	0,97		0,81	3,41
Asperula cynanchica L.		0,97		2,46	0,86
Pimpinella saxifraga L.	0,64		0,50	0,55	0,21
Polygala comosa Schkuhr		0,64	0,23	0,55	
Filipendula vulgaris Moench			0,96	2,19	1,06
Anthyllis vulneraria L. ssp. alpestris (Kit.) Asch. et Gr., 4: 0,41 - 5: 1,51; Prunella grandiflora (L.) Scholler, 4: 0,54 - 5: 1,06; Stachys recta L., 3: 3,29 - 4: 0,27; Allium carinatum L., 4: 0,82 - 5: 0,43; Centaurea scabiosa L., 4: 1,09 - 5: 5,14; Campanula glomerata L., 2: 2,22 - 4: 0,41; Trifolium montanum L., 2: 0,06; Bothriochloa ischaemon (L.) Keng, 4: 1,36; Pseudolysimachion barrelieri (Schott ex R. et S.) Holub, 5: 1,70.					
<b>Expected companion species</b>					
Vincetoxicum hirundinaria Medicus	0,32	0,95	0,33		0,32
Peucedanum oreoselinum (L.) Moench		1,28	1,00	1,09	6,63
Anthericum ramosum L., 2: 0,13 - 5: 0,43; Agrimonia eupatoria L. 3: 0,17 - 5: 0,33; Thalictrum minus L.: 5:					
<b>Mesophylous companion species (differential of alliance)</b>					
Lotus corniculatus L.	2,53	1,28	1,98	3,28	1,71
Briza media L.	2,55	3,81	1,32	1,09	3,01
Centaurea jacea L.	4,48	2,24	1,30	1,36	2,32
Festuca rubra L.	4,43	2,22	8,60	3,01	2,78
Leontodon hispidus L.	3,82	0,64	0,98		2,56
Carex flacca Schreber		2,22	0,50	1,09	0,44
Dactylis glomerata L.	4,44	4,78	5,57	4,10	
Silene vulgaris (Moench) Garcke	2,55	1,61	1,66	1,37	
Vicia cracca L.	0,95	0,95	0,50	1,09	
Stachys officinalis (L.) Trevisan	5,12		1,00	1,09	1,27
Plantago lanceolata L.	0,32			0,55	0,32
Lathyrus pratensis L.	0,64	0,95	0,98		
Galium mollugo L.	1,59	2,24	2,28		
Veronica chamaedrys L.	0,64	1,59	1,64		
Presl, 4: 1,65 - 5: 0,21; Trifolium pratense L., 3: 0,50 - 4: 1,64; Holcus lanatus L., 3: 1,64 - 4: 1,37; Rumex acetosa L., 3: 0,16 - 4: 0,27; Trifolium repens L., 2: 1,26; Molinia arundinacea Schrank, 5: 2,13; Plantago media L., 5: 0,43; Taraxacum officinale Weber (aggregato), 5: 0,43; Genista tinctoria L., 5: 0,21; Leucanthemum vulgare Lam., 5: 0,09.					
<b>Character and differential species of the class Molinio-Arrhenatheretea</b>					
Achillea millefolium L.	4,44	2,86	2,64	1,64	1,70
Knautia arvensis (L.) Coulter	0,64		0,66	0,55	
Dianthus superbus L.	0,64			0,60	0,64
Ranunculus acris L.	0,32		0,98		
Agrostis tenuis Sibth.	0,48				1,29
Festuca arundinacea Schreber		0,95	4,29		
Geranium pyrenaicum Burm. f.			1,00		1,49
Poa pratensis L.				1,65	0,21
<b>Character and differential species of the class Trifolio-Geranietea</b>					
Buphthalmum salicifolium L.		0,48	0,98	1,09	0,65
Hypericum perforatum L. ssp. veronense (Schrank) Frohlich		1,28	0,33		0,86
Anthoxanthum odoratum L.	0,16			1,09	2,60
Clinopodium vulgare L., 2: 0,95 - 3: 0,98; Trifolium rubens L., 4: 2,19 - 5: 1,7; Coronilla varia L., 3: 1,98.					
<b>Character species of the order Prunetalia spinosae Tx. 52</b>					
Glechoma hederacea L.		0,97	0,49		
Populus tremula L.	0,32				
Clematis vitalba L.		0,97			
Euonymus europaeus L.			2,62		
Cornus sanguinea L.			0,66		
Rosa canina L. sensu Bouleng.					0,21
Number of other species. 1: 17; 2: 13; 3: 17; 4: 20; 5: 19.					



The five meadows belong clearly (Table 1) to the class *Festuco-Brometea* and particularly to the *Mesobromion* Br. -Bl. et Moor 38 alliance; they present a high number of species of the abovementioned class, and of the species that characterize this alliance. In all meadows, forest margin species, traceable to the class *Trifolio-Geranietea*, are present. In the meadows abandoned from more time, these species tend to be replaced by species of the order *Prunetalia* Tx. 52, belonging to the class *Quercu-Fagetea* Br. -Bl. et Vlieg. in Vlieg 1937, that indicate a reforestation of the surface.

Linear regressions (Figure 1) showed a gradual loss of biodiversity due to the depletion of 'number of total species', 'number of monocotyledon species', 'number of dicotyledon species', and 'Shannon Index'. The decrease of 'number of total species' was mainly due to the increase of coverage percentage of tall species and the decrease of the number of short species (Table 1).

A drastic increase of coverage percentage of monocotyledon species was also observed, but the major effect of abandonment was the increase of percentage of *Brachypodium caespitosum* that ranged from 3.21% (3 years) to 25.50% (25 years). Finally, the litter thickness was also positively related to the period of abandonment. The increase of litter layer could be the consequence of the continuous release of dead tissues on the soil, as well as the increase of *Brachypodium caespitosum*, the litter of which is difficult to decompose. Moreover, the increase of litter could also help to explain the reduction of species number as a consequence of a more difficult germination of seeds on a soil with a thick litter.

## Conclusion

As a consequence of abandonment, *Mesobromion* alliance meadows are progressively invaded by *Quercu-Fagetea* species. This process is rapid and is strongly related to the period of abandonment. The mowing is the only management practice that maintains a high level of floristic biodiversity. Therefore if biodiversity is a major priority, the cost of mowing should be taken up by the public administration.

## References

- Hurst A. and John E. (1999) The biotic and abiotic changes associated with *Brachypodium pinnatum* dominance in chalk grasslands in south-east England. *Biol. Conserv.* 88: 75-84.
- Lasen C. (1989) La vegetazione dei prati aridi collinari submontani del Veneto. *Atti del simposio della Società Estalpino-dinarica di fitosociologia*, Feltre 29/6-3/7 1988, pp. 147-160.
- Oberdorfer E. (1978,1983) Süddeutsche Pflanzengesellschaften, Teils II and III. G. Fischer, Jena1-355, 1-455.
- Pignatti S., 1982. Flora d'Italia, Edagricole. 3 voll.
- Poore M. E. D. The Use of Phytosociological Methods in Ecological Investigations: I. The Braun-Blanquet System. *The Journal of Ecology*, Vol. 43, No. 1. (Jan., 1955), pp. 226-244.
- Ziliotto U., Andrich O., Lasen C. and Ramanzin M. (2004). *Tratti essenziali della tipologia veneta dei pascoli di monte e dintorni*. (vol. 1° e 2°, pp. 1-268 e 1-204). VENEZIA: Regione del Veneto, Accademia Ital. Sc. Forestali.

# The influence of cattle grazing on grasslands situated in different habitat conditions in Poland

Wasilewski Z.

*Institute for Land Reclamation and Grassland Farming at Falenty, Department of Meadows and Pastures, 05-090 Raszyn, Poland*

## Abstract

Permanent grasslands in Poland are valuable cutting meadows and grazing pastures with rich flora and fauna. Moreover they diversify and adorn the landscape and are protection tool of waters and soils. Despite these characteristics, significant areas of grasslands are not utilized anymore and they are losing their natural value (they are invaded by shrubs and trees). One of the cheapest and effective methods of maintaining them in agriculture landscape and their natural value is cattle grazing. During the years 2002-2004, a study was conducted on grasslands corresponding to three habitats: mineral soil meadows (A), moorshed meadows (B) and flooded meadows (C). Dairy cows and heifers grazed on areas separated by electric fences (habitats A and B) and in habitat C the extensive (open), 24-hour grazing was used. Their moisture evaluated with the phytoindication method, in a 10-level scale, was 5.9, 5.4 and 7.8 respectively, but with the oven method 21, 36 and 60%. In swards of habitats A and B grasses were dominant (71%), in habitat C it was grasses and sedges (52 and 31% respectively). At the end of the grazing period the height of grazed sward was 20 cm in habitat A, 50 cm in habitat B and 110 cm in habitat C. The depth of tracks left by animals was 4, 5 and 30 cm, respectively. Utilisation value of sward measured in a 10-level scale was 6.7, 7.2 and 4.1 respectively.

Keywords: habitat, grazing, sward, soil moisture

## Introduction

In Poland permanent grasslands are valuable cutting meadows and grazing pastures with rich flora and fauna. Moreover they diversify and adorn the landscape and are protection tool of waters and soils. Their economic significance and natural richness depend on many factors. The most important ones are habitat conditions and way of utilisation. Significant areas of grasslands are not utilized anymore and they are losing their natural value (they are invaded by shrubs and trees). One of the cheapest and effective methods of maintaining grasslands and their natural value is cattle grazing. Cattle can effectively graze either on very dry or on very moist and even wet grasslands. A study concerning this problem was conducted in years 2002-2004. The aim of this study was evaluating sward quality (botanical composition) of grasslands situated in different habitats and the influence of grazing animals (cattle).

## Materials and methods

The botanical composition of the swards was evaluated on fresh plant material by the use of a sorting and weighing method, moisture of soil – with oven method and the useful value of sward (Lwu) in a 10-point scale according to Filipek method (1973). The moisture conditions of the habitats were evaluated in a 10-point scale by the phytoindication method using Lw coefficient elaborated by Oświt (1992).

Classification of habitats was based on the typology of meadows according to Grzyb and Prończuk (1994), Grzyb (1996) and Wasilewski (2002). The study was conducted on permanent grasslands and lands periodically grazed, situated on the following habitats: A – mineral soil meadows, B - moorshed meadows and C – flooded meadows. According to the phytoindication method, the values of Lw coefficient of plant communities were calculated and the moisture conditions of habitats were evaluated.

## Results and discussion

In habitats of mineral soil meadows, Lw coefficient was 5.9, in moorshed meadows 5.4 (fresh soil habitats) and in flooded meadows 7.8 (moist and wet soil habitats) (Table 1). In habitats of mineral soil meadows and moorshed meadows, a rotational grazing was conducted and the animals received calculated amounts of concentrates; in habitats of flooded meadows, free grazing was applied. Depending on soil moisture and intensity of utilisation, different plant communities were observed in the three habitats. In every case, the yield was mainly produced by grasses with different participations of other plant groups (Table 1). A small participation of *Trifolium repens* L. in sward was noticed.

Table 1. Botanical composition – plant groups (% yield)

Plant group	Habitat		
	A	B	C
<i>Poaceae</i> ( <i>Gramineae</i> )	70.7	71.3	52.2
<i>Fabaceae</i> ( <i>Papilionaceae</i> )	2.5	5.7	-
<i>Magnoliopsida</i> (other <i>Dicotyledones</i> )	26.8	22.6	16.5
<i>Carex</i> spp., <i>Juncus</i> spp.	-	0.4	31.3
Lwu	6.7	7.2	4.1
Lw	5.9	5.4	7.8

In habitats A and B, about 75% of total yields were produced by grasses with a small contribution of legumes and a significant participation of weeds and herbs (about 25% of yield). In flooded meadows (habitat C), grasses produced about the half of the yield, and sedges, rushes and horsetails about 1/3 (Table 1). In habitats A, 26 plant species were observed, in B 31 and in C 28. In habitat A, the most abundant grass species were (by decreasing order): *Poa pratensis* L., *Lolium perenne* L., *Dactylis glomerata* L., *Agropyron repens* L.; in B: *Poa pratensis* L., *Phalaris arundinacea* L., *Alopecurus pratensis* L., *Agropyron repens* L., *Festuca rubra* L., and in C – *Glyceria maxima* (Hartm.) Holmb., *Glyceria fluitans* (L.) R. BR., *Phalaris arundinacea* L., *Agrostis stolonifera* L.), *Alopecurus pratensis* L., *Phragmites australis* (Cav.) Trin. ex Steud. Among dicotyledonous plants, *Cirsium arvense* (L.) Scop.), *Potentilla anserina* L., *Taraxacum officinale* F. H. Wigg., *Ranunculus acris* L. s. s. were the dominant species in habitat A; in B it was *Taraxacum officinale* F. H. Wigg., *Urtica dioica* L., *Ranunculus acris* L. s. s., *Ranunculus repens* L. s. s., and in C, *Polygonum amphibium* L., *Potentilla anserina* L. In habitat C, the most abundant sedge and rush species were: *Carex* spp., *Acorus calamus* L., *Typha latifolia* L., *Juncus conglomeratus* L. em. Leser.

Calculated coefficient Lwu shows (Table 1) that plant communities in habitats of moorshed meadows and mineral soil meadows can be classified among the group of good useful value (range of values 6.1-8) and in habitats of flooded meadows to group of poor value (range 3.1-6). The values of Lwu coefficient depended on the participation of valuable grasses, dicotyledonous species and sedges.

In habitats of flooded meadows, animals grazed first on drier uplifts. In these habitats, the first species eaten by animals were: *Phalaris arundinacea* L. and *Alopecurus pratensis* L., and next *Glyceria maxima* (Hartm.) Holmb., and even *Carex* spp. *Acorus calamus* L., *Typha latifolia* L., *Juncus conglomeratus* L. em. Leser. were not eaten by animals.

Table 2. Sward height structure of swards in the three habitats

Habitat	Sward height structure (% cover per layer)					
	< 5 cm	6-10 cm	11-20 cm	21-50 cm	51-100 cm	>100 cm
A	4.5	91.0	4.5			
B	26.1	51.8	20.2	1.9		
C	0	2.9	24.5	30.2	38.9	3.5

Sward height (Table 2) measured in August in habitats of mineral soil meadows and moorshed meadows were 20 cm; only a few groups of plants, particularly in places of dungs, exceeded this height. Height below 5 cm was stated on over ¼ of area in very intensively grazed parts of sward of moorshed meadows. Significantly different was sward height in flooded meadows. Here the plants were not eaten below 5 cm, and even 10 cm, in the range 6-10 cm the sward was damaged but not eaten. The sward height in the range 20-100 cm, covered nearly 73% of area. As a result, reedbed communities (*Phragmition*) were noted in these habitats.

It can be stated, that plant density and carrying capacity of sod is inversely correlated with soil moisture and the content of soil organic matter. Therefore, grassland located in habitats of flooded meadows, on organic very moist soils, cannot be grazed because of insufficient soil structure. Grazing cows exert a pressure on sod, amounting about 3 - 4 N per cm<sup>2</sup>. In habitats of mineral soil meadows and moorshed meadows, this issue was not stated, because soil in habitats of mineral meadows has a low content of organic matter, a high mechanical fraction and a significantly lower water capacity. However in moorshed meadows the soil was very drained. The critical water content in pasture soils, for avoiding sod damage by animals, is below 50% of soil capacity (Table 3).

Table 3. Moisture of soil (% soil capacity) and depth of tracks left by cows (cm)

Specification	Habitat		
	A	B	C
Moisture of soil	21.2	36.0	59.8
Maximum depth of tracks	4	5	30

## Conclusion

Grazing of grasslands located in different, particularly difficult habitats of flooded meadows has high natural meaning. Their economic significance is rather low because of two particular reasons. The first reason is the high consumption of energy for moving animals (cattle) on difficult, sticky area, and the second one is the short grazing duration that is restricted to summer, when the area is dry. But just then the plants are very mature and have low nutritive value. The study showed that cattle grazing, even in so difficult habitats as flooded meadows, can be a good method for their protection, for avoiding unfavourable plant successions, and the development of bushes and trees.

## References

- Grzyb S. (1996) Typologiczny podział użytków zielonych w Polsce oraz charakterystyka i zasady identyfikacji ważniejszych jednostek. Wyd. IMUZ. W: Mat. Semin. pt. *Podstawy typologicznego użytków zielonych i zasady ich inwentaryzacji*. p. 7-21.
- Grzyb S. and Prończuk J. (1994) Podział i waloryzacja siedlisk łąkowych oraz ocena ich potencjału produkcyjnego. Wyd. SGGW Warszawa. W: Kierunki rozwoju łąkarstwa na tle aktualnego poziomu wiedzy w najważniejszych jego działach. *Mat. z Ogólnopolskiej Konf. Łąkarskiej*, Warszawa 27-28 września 1994, p. 51-63.
- Filipek J. (1973) Projekt klasyfikacji roślin łąkowych i pastwiskowych na podstawie liczb wartości użytkowej. *Post. Nauk Rol.* nr 4 p. 59-68.
- Oświt J. (1992) Identyfikacja warunków wilgotnościowych w siedliskach łąkowych za pomocą wskaźników roślinnych (metoda phytindykacji). W: Hydrogeniczne siedliska wilgotnościowe. *Bibl. Wiad. IMUZ* 79 p. 39-67.
- Wasilewski Z. (2002) Charakterystyka typologiczna użytków zielonych oraz sposoby użytkowania priorytetowych zbiorowisk roślinnych umożliwiające zachowanie ich walorów przyrodniczych. W: Aktualne problemy mokradeł. Walory przyrodnicze mokradeł a ich rolnicze użytkowanie. *Woda, Środowisko, Obszary Wiejskie*. Rozprawy naukowe i monografie nr. 4, p. 62-81.

# **Economical and ecological effects of meadow and pasture production on a long reclaimed object in the Por river valley**

Prokopowicz J., Jankowska-Huflejt H. and Burs W.

*Institute for Land Reclamation and Grassland Farming, Falenty 05-090 Raszyn, Poland*

## **Abstract**

The study aimed to assess the economical and ecological effects of meadow and pasture production on a long reclaimed object in the Por River valley. Seven villages in the Sułów commune, Zamość County, were the study objects. Reclaimed grassland situated near very good arable grounds was used for 45 years. Changes resulting from the regulation of air and water conditions of soils in the river valley were confronted with climatic and physiographic conditions, agricultural characteristics of soils and water relations in the object. Land use, plant and animal production on permanent grasslands, gross production in corn units per ha croplands and per capita, and coefficients of reproduction and soil degradation were presented. A question was formulated - what is the future of such reclamation objects in Poland? Has one to restore the reclamation system and intensify agricultural use or rather return these lands to nature?

The study confirmed working hypothesis that under current socio-economic conditions the formerly reclaimed grassland objects situated near very good arable lands should be returned to nature and not modernized.

Key words: economy, ecology, meadows, pastures, land reclamation, the Por River valley

## **Introduction**

Many unfavourable changes have taken place in permanent grasslands during the last decades. Advanced running down and destruction of reclamation facilities (Mioduszewski, 1992) caused uncontrolled water outflow (Łoś, 2005), particularly near basic water courses, and excessive moisture near non-preserved detail ditches. Such evolutions lead to, in extreme cases, their total abandonment. So, the question arises - what to do with such grasslands? To restore the reclamation system and prolong their intensive use or rather „return” them to nature? Working hypothesis of this study is that such long reclaimed grasslands in Poland, particularly those located near arable lands with very good soils, should not be improved but rather left unmanaged.

## **Materials and methods**

The Por River valley is situated in the western part of Zamość Valley, in the Lublin region. The area with a physiographic pattern suitable for agricultural production is characterised by average annual precipitation of 630 mm and mean air temperature of 7.3°C. Arable grounds are dominated by loess soils qualified, in view of their agricultural potential, to be good to very good for wheat complex production. The seven villages included in the study have an average population density of 88-100 persons per 100 ha croplands in the 1960s and 70 persons 100 ha<sup>-1</sup> in 2002.

Before their reclamation, starting in 1959, large parts of the valley were marshlands. Most meadows were not mown and the mean hay yield of the total surface recorded as meadow was

1.0 to 2.5 t ha<sup>-1</sup>. Therefore, reclamation was a decisive step towards agricultural use of the valley and grassland production intensification.

Reclamation detailed in this study covers 1730 ha of permanent grasslands. To characterise the evolution of this area, we used statistical and survey data collected before reclamation (1953), between 1963 and 1965 and between 2002 and 2006, more than forty years after reclamation.

Monographic method was used in this study. An assessment of the intensity of agricultural production (more precisely – the intensity of organisation of agricultural production) was made with the point method (Kopeć, 1968), comparing the content of starch and protein (plant forages) and labour input (remaining agriculture products) in relation to 1 dt of crops.

## Results and discussion

Regulation of air and water conditions and post-reclamation management based chiefly on complete cultivation method led to the appearance of sward communities including leguminous (red and hybrid clovers (*Trifolium pratense* and *Trifolium hybridum*), the black medic (*Medicago lupulina*), the bird's foot trefoil (*Lotus corniculatus*)) and grasses species (tussock-grass (*Poa pratensis*), meadow and red fescues (*Festuca pratensis* and *Festuca rubra*)). Combination of efficient reclamation system and technological development resulted in a remarkable increase of hay production in the valley with weighed mean hay yield of 5.16 t ha<sup>-1</sup>. On the meadows intensively managed this yield reached 6.0 t ha<sup>-1</sup> and even 11.0 t ha<sup>-1</sup> in some villages.

Today, 40 years later, status of permanent grasslands in the Por River valley depends largely on marshland re-development in the close vicinity of the river and on soil moisture increase in more elevated areas (tab. 1). Based on botanical analyses and field observations performed in 2006 one may conclude that according to current agricultural priorities in our country the grasslands of the Por valley should return to their initial conditions. In fact, this phenomenon has already taken place.

Table 1. Percentage share by the different plant groups in the meadow swards in the Por River valley

Groups of plants	1965				2006				
	1	2	3	mean	1	2	3	4	mean
Grasses, including:	89.0	84.3	74.1	82.5	41.3	7.6	26.3	27.4	25.7
Very good*	57.8	38.6	39.8	45.4	39.7	3.1	8.3	6.9	14.5
Good	18.6	15.3	21.8	18.6	0.5	0.7	3.5	18.1	5.7
Poor	12.6	30.4	12.5	18.5	1.1	3.8	14.5	2.4	5.5
Sedges and rushes	0.1	1.7	2.3	1.4	5.3	15.4	2.2	7.1	7.5
Legumes	6.2	1.5	13.4	7.1	1.3	20.5	3.8	14.4	10.0
Herbs and weeds	5.1	12.2	10.1	9.1	29.0	36.8	35.7	25.8	31.8
Horsetails	-	-	0.1	0.0	23.1	19.7	35.5	25.3	25.9

\*due to their fodder value

After reclaiming permanent grasslands the animal production, especially cattle production expressed in LU stock per 100 ha of croplands, markedly increased (tab. 2) as an effect of increased amount of fodder production from meadows and pastures and of economic boom of the 1970s in agriculture. Later, the production of meadows and pastures declined, following the degradation and technical run down of reclamation system, chiefly of the detailed reclamation. Lower production of meadows and worse economic situation of the 1990s have drastically reduced cattle stock. It should be underlined, however, that recently the animal productivity has increased. Changes have also taken place in the crop structure.

Table 2. Technico-economical parameters describing the agricultural production in 7 villages of the Por River valley from 1953 till 2002

Parameters of agricultural production	Years								
	1953	1963	2002	1953	1963	2002	1953	1963	2002
Animal stock (LU/100 ha croplands)	productive stock			cattle			pigs		
	43.0	60.5	51.3	35.0	51.0	29.6	7.2	7.6	21.6
Crop structure, %	cereals			tuber crops			fodder crops		
	53.7	57.1	71.1	18.6	24.2	15.5	22.3	11.1	2.4
Plant yields (t per ha)	cereals			potatoes			sugar beets		
	1.5	1.7	3.7	14.2	20.5	20.1	20.7	32.8	45.0

To better illustrate the relationship between animal production and grassland status in the Por River valley a balance of hay and green fodder (calculated as green fodder) per 100 ha of croplands was presented (Table. 3). In the same way, the proportion of the fertilisation need covered by manure was evaluated (Table. 3).

Table 3. Ecological parameters describing the agricultural production in 7 villages of the Por River valley from 1953 till 2002

Parameters of ecological production	Year									
	1953	1963	2002	1953	1963	2002	1953	1963	2002	
Hay* and green fodder balance t/100 ha croplands	demand			fulfilment			% of demands			
	662	941	358	458	799	239	69.1	85.0	66.7	
Manure balance	577	753	537	522	698	317	90.5	92.7	59.0	
Coefficients of soil reproduction/degradation	From field production			from manure			total			
	-0.53	-0.82	-0.75	+0.35	+0.48	+0.22	-0.18	-0.34	-0.53	
Coefficient of production intensity (point/100 ha croplands)	plant			animal			agriculture in total			
	114.6	141.1	130.8	138.1	187.6	120.3	252.7	328.7	251.1	
Total production	Plant			animal			total			
	corn units**/ha	18.51	28.64	43.45	14.03	21.0	20.94	32.54	49.64	64.39
	corn units per capita	18.38	28.40	62.42	13.93	20.89	30.08	32.3	49.3	92.5

\* expressed in green fodder; \*\* - technical-biological standard for equal expression of value different products

Basic and detailed reclamation interfered in the natural environment of the valley. In the post-war period such reclamations were required and justified. Lower genetic potential of crop plants in those years and a lack of mineral fertilisers forced farmers to extend the area of fodder production in order to cover population needs and to increase their incomes. Increasing yields of bulk fodder from grasslands in reclaimed valley allowed, on the one hand, to decrease the area of fodder plant production and to use it for market crops like cereals, sugar beets, rape etc. (tab. 2). Larger cattle stock, on the other hand, increased the production of farm manure, improving the balance of organic matter in arable lands soils.

Calculated coefficients of reproduction and degradation of soil organic matter in studied villages confirm a positive effect of land reclamation in the valley on reproduction of organic matter and a negative effect of altered crop structure i.e. increased area of cereals, sugar beets and rape crops. Total coefficient of reproduction of soil organic matter was, however, higher.

Level of intensity of agricultural production markedly increased (tab. 3) in studied villages in the years 1953-1963 after the accomplishment of the reclamation system. Total production in corn units and its indices per 100 ha of croplands and per capita also increased. In 2002, in spite of return to nature of about 70% of reclaimed area, global production significantly increased. It was influenced by the increase of global plant production (higher yields of new



varieties) and of animal performances (high dairy cows performances and an increase of pigs production). It thus appears that, in spite of an important proportion of the Por River valley returns to nature the production and people's incomes did not decrease but rather substantially increased.

## **Conclusion**

Reclamation of permanent grasslands in the Por River valley was, when initiated, economically effective. Indeed, it allowed for utilising, to the farmers' benefit, larger part of the river valley surface, which was previously barren. This through the development of high quality meadows and pastures enabled to increase animal stock and milk production. So, reclamation system of the valley indirectly increased the intensity of agricultural production, with also an improvement of the quality of neighbouring arable soils through increased organic matter valorisation, and farmers' incomes.

Noteworthy, the reclamation system constructed 45 years ago did not irreversibly worsen the habitat conditions of the valley. After an effective use of soil potential by farmers during the operational hours of these technical facilities, their degradation let the natural forces take the advantage. Now farmers and local authorities have to decide what to do with the marshland surfaces of the Por River valley.

Results of this study confirmed the hypothesis that under current socio-economic conditions restoration of this reclamation system is not necessary – there is no such economic need. But in the future, should the need of intensifying agricultural production arise, it will be possible to construct modern reclamation system to reach such a target.

## **References**

- Kodeks Dobrej Praktyki Rolniczej (2002) [Code of Good Agricultural Practices] Ministerstwo Rolnictwa i Rozwoju Wsi, Ministerstwo Środowiska, 96 pp.
- Kopeć B. (1968) Systemy gospodarcze w rolnictwie polskim. [Economic systems in Polish agriculture] Warszawa: PWRiL.
- Łoś M.J. (2005) Melioracje rolne w procesie transformacji. [Agricultural land reclamation in the period of transformation] Wiadomości Melioracyjne i Łąkarskie nr 3 p. 113-118.
- Mioduszewski W. (1992) Wybrane problemy eksploatacji systemów wodno-melioracyjnych. [Selected problems of the exploitation of water-reclamation systems] Melioracje Rolne Biuletyn Informacyjny nr ½.

# Fodder productions in organic suckling beef farming systems: impact of the driving forces that have led to system conversion to organic rules

Jamar D.<sup>1</sup>, Stilmant D.<sup>1</sup> and Baret P.V.<sup>2</sup>

<sup>1</sup> Walloon Agricultural Research Centre – Farming Systems Section, B-6800 Libramont, Belgium

<sup>2</sup> Université catholique de Louvain - Unité de génétique (GENA), Croix du Sud, 2 bte 14, B-1348 Louvain-la-Neuve, Belgium

## Abstract

A socio-economical typology focusing on the re-conversion motivations and perspectives of farmer producing organic beef have allowed to define four main groups of breeders: 'environmentalist', 'market', 'opportunist' and 'holist' breeders. Within these main types, the diversity of the fodder production schemes was subsequently characterized through a detailed survey performed on four farms during two years. The recorded data included, among others, fodder crop management schemes and yields, and nitrate load at the end of the season as indicator of the environmental pressure. The results highlighted higher production performances in the 'market' driven system than in the environmentalist and holist systems. The former correspond to an intensification of the practices in terms of livestock production, through feedstuffs importation, leading to higher livestock density and so to a higher availability of farm manure which is associated with grassland ploughing, to increase fodder crop productivity. Such practices lead to a higher nitrate load and increase leaching risk in 'market' driven systems and question the environmental return expected from such systems of production. These results challenge the premium the market driven systems received in the second CAP pillar context.

Keywords: organic, farming systems, fodder production, beef, environment

## Introduction

The first concern of organic agriculture pioneers wasn't to preserve the environment *per se* but, aside from the production of healthy food, to improve the richness and the stability of the soil by restoring its organic matter and avoiding synthetic inputs. In the nineties, environmental issues have been integrated in the organic farming functions and organic farming is now part of the Rural Development Program and more especially of the Agri-Environmental Schemes. Other concerns such as biodiversity, animal welfare... have been added later to the organic rules (Macilwain, 2004a).

Agri-environmental policy aim to switch a proportion of financial assistance to farmers from commodity support to incentives to carry out environmentally beneficial measures (Ovenden *et al.*, 1998). So, does organic farming lead to clear benefit for the environment?

Taking into account nitrate runoff the differences between organic and conventional systems are less clear (Macilwain, 2004b). Indeed, to maintain their productivity, organic systems can intensify some rotations and practices with an important negative environmental impact such as ploughing in clover rich grasslands to produce cereal. As illustrated by Eriksen *et al.* (1999) in Danish dairy systems, this can lead to nitrate concentrations in drainage water higher than the European threshold of 50 mg l<sup>-1</sup>. Organic systems can also intensify their practices by purchasing fertilizer and fodder, leading to level of production diverging from local capacity (Granstedt, 2000) and to lowest environmental performances. Due to the high

cost of the organic inputs, as fertilizers or animal feeds, we can draw the hypothesis that such intensification scheme that seems to be in opposition to the environmental objectives of the organic way of production could only be operated by the systems having an access to the organic market. In addition they are boosted by the market demand which focalize on the same product specifications as those occurring in the conventional market. So there should have a link between (1) environmental pressure and fodder production performances, both reflecting this intensification scheme, and (2) products commercialization (market support) schemes in organic beef farming systems. The aim of this paper is to test this hypothesis.

## Materials and methods

To test this hypothesis we followed up, during two seasons, four farms representative of three of the four main farm types identified by Jamar and Stilmant (2006) on the basis of the internal driving forces (farmer's project) and of the signals from the socio-economic environment in which farmer exerts his activity (market, premiums, and social demand) that have led to system reconversion to organic rules (Table 1).

Table 1. Typology based on the conversion motivations taking into account external (sanitary crisis, market, premiums, social demand) and internal (farmer objectives and projects) socio-economical driving forces. In bold: percentage of the 157 converted units with a suckling herd took into account and livestock stocking rate per hectare of UAS.

Breeder's projects	External signals				Organic conversion mode
	Sanitary crisis in beef sector	Public support : organic premiums	Organic produce market development	Social demand and consumption	
Decreasing agricultural activity	+++	+++	+		1° Financial opportunity (22%, 1.4 LU ha <sup>-1</sup> )
Livestock = auxiliary and/or extensive	+	+++	+	++	2° Environmental conversion (40%, 1.2 LU ha <sup>-1</sup> )
Livestock = Produce valorisation	+++	+++	+++	+	3° Conversion for the market (31%, 1.8 LU ha <sup>-1</sup> )
Looking for a new farming system coherence	++	++	++	+++	4° Farming system, holistic conv. (7%, 1.2 LU ha <sup>-1</sup> )

One of these farms (ENV farm) is representative of the cluster qualified as '**environmental conversion**', integrating 40% of the converted units with a suckling herd. The productivity of these systems didn't rely upon produce marketing but well on alternative agricultural function in phase with social demand: production of an environment of high quality with the support of agri-environmental premiums. On such farms, the professional activity is seen as a way to make use of the land, rather than a way to develop a product.

Two of the farms followed up (MAR farms) are included in the cluster with the label '**conversion for the market**' (31%). These farmers have redefined their business plans and their technical and economic orientations following the developments of a demand for produce labeled as organic. They are aware that, to valorize their products in a long 'sTable-to-Table' chain, it is necessary to meet both the constraints of organic breeding rules and the specifications from the downstream food chain which remain mainly conventional.

The fourth farm (HOL farm) is representative of the ‘**holistic farming system conversion**’ cluster (7%). These farmers are looking for coherence and consistency between technical, economical and environmental imperatives, between their products and their consumers, between organic rules and retailers demands, etc. These innovative farmers gradually perceive organic rules as being the normative translations of the principles to which they subscribe, rather than simple constraints.

The fodder management (fertilization scheme, grazing and cutting strategy,...) and production of these farms were recorded during two seasons, in 2003 and 2004. In order to quantify the environmental risk, nitrate profiles were measured, between the 15<sup>th</sup> of November and the 15<sup>th</sup> of December, in a minimum of 10 fields per farm, 3 samples collected per field. Excepting in the grazed grasslands, the samples integrated the 0-30 cm and the 30-60 cm profiles. In the grazed grasslands, each sample is the mixture of 30 soil sub-samples collected in the 0-30 cm profile (Hennart *et al.*, 2005). This adapted sampling scheme is required to take into account the heterogeneity of nitrogen deposition through animal urination, leading to patches with deposition as high as 400 to 1200 kg N ha<sup>-1</sup>.

## Results and discussion

### *Fodder management and production*

The ENV farm, representative of the ‘**environmental conversion**’ group, was characterized by an UAS of 72 ha and a stocking rate of 1 LU per ha of UAS. This means a herd of 50 suckling cows. 80% of the products were sold at weaning for conventional fattening or kept for breeding; the remaining 20% were fattened as steers or heifers. Cull cows are linked to a 18% replacement rate and also sales for conventional market. 7% of UAS is devoted to cereals crops.. Surface productivity observed was of 6 T of net dry matter per hectare of grassland and of 2.4 T of cereal ha<sup>-1</sup>. These cereals allow covering all the herd needs. Fertilization schemes were based on composted manure valorization. The ENV farm spread 15 T ha<sup>-1</sup>, every year on temporary grasslands and every two years on permanent cut and grazed grasslands. Nitrogen fixation by legumes accounted for 90 % of the inputs in the system.

The two **MAR** farms were characterized by a mean UAS of 60 ha and by a stocking rate of 1.7 LU ha<sup>-1</sup>. This means a herd of 56 suckling cows with the production of 12 cull cows (23%), of 8 heifers and of 24 fattened bulls. In these farms, we observed the development of fodder crops, reaching up to 20% of the UAS at the detriment of permanent grasslands. Such strategy, based on the stimulation of organic matter mineralization following legume rich grasslands ploughing, allowed to reach good cereal (4 T ha<sup>-1</sup>) and haylage (8.5 T of utile dry matter per hectare) productions. Fertilization schemes are based on composted manure valorization with spreading of 20 T ha<sup>-1</sup> on temporary grasslands, 10 T ha<sup>-1</sup> on permanent cut and grazed grasslands and 10T ha<sup>-1</sup>, every two years, on the exclusively grazed grasslands. Nitrogen fixation by legumes accounted for 43 % of the inputs in the system.

The **HOL** farm was characterized by a UAS of 53 ha and a stocking rate of 1.3 LU ha<sup>-1</sup>. As in many of these ‘holistic systems’, this farm had dairy Normand bred (3700 l cow<sup>-1</sup>) and suckling herds (40% of the cows). Apart from the cull cows linked to a 19% replacement rate and sold on conventional market, all the animals were fattened on the farm: 20% as baby beef, 20% as young bulls, 40% as steers and 20% as heifers. 79% of its UAS was covered by grasslands. The remaining surface was covered by fodder (11%) and commercial (9%) crops. So 98% of the feeding needs of the herds were self-produced. Surface productivity observed on the HOL farm was close from 7 T of utile dry matter per hectare of grassland and 2.7 T of cereal ha<sup>-1</sup>, this with fertilization schemes based on composted manure valorization. 10 T ha<sup>-1</sup> were spread every year on crops and temporary grasslands and every two years on permanent

cut and grazed grasslands. Nitrogen fixation by legumes accounted for 94% of the inputs in the system.

#### *Nitrate profiles measurement*

**In cropped land**, the results obtained in 2003, a year characterised by a very hot and dry summer, highlighted N-NO<sub>3</sub><sup>-</sup> loads after cereals higher than 100 kg ha<sup>-1</sup> without farm effect (F(3,7) = 2.0; p = 0.197). In 2004, a ‘farm’ effect was highlighted (F(5,25) = 6.0; p < 0.001). The farms were separated in two groups. A first group included the MAR farms, with a mean load of 81.9 kg N-NO<sub>3</sub><sup>-</sup> ha<sup>-1</sup>. The second group integrated the HOL farm (24.1 kg N-NO<sub>3</sub><sup>-</sup> ha<sup>-1</sup>) and the ENV farm (33.7 kg N-NO<sub>3</sub><sup>-</sup> ha<sup>-1</sup>).

**In grassland**, 29 and 32 fields were sampled, respectively, in 2003 and in 2004. In 2003, with a mean nitrate load of 21.4 N-NO<sub>3</sub><sup>-</sup> ha<sup>-1</sup>, no ‘farm’ impact was highlighted (F(3,17) = 1.0; p = 0.418). In 2004, as for cropped land, the HOL farm (6.7 kg N-NO<sub>3</sub><sup>-</sup> ha<sup>-1</sup>) led to significantly (F(5,21) = 3.0; p = 0.033) lower environmental impact than the two MAR farms (31.0 kg N-NO<sub>3</sub><sup>-</sup> ha<sup>-1</sup>). The ENV farm (20.2 kg N-NO<sub>3</sub><sup>-</sup> ha<sup>-1</sup>) comes in the intermediate position group. However this conclusion has to be taken with caution as only 3 grasslands from this ‘holistic’ system were sampled in 2004.

### **Conclusions**

These results, to be considered with caution as they were obtained on a small number of farms, support the hypothesis that, even in the case of suckling cows herd for bovine meat production which is generally more extensive, it is legitimate to question the sustainability of the systems converted to organic farming for the market in terms of environmental return for the premium they receive and fertility preservation. Indeed, to respond to market demand, they maintain intensive practices (importation of a huge amount of N under concentrate feeds, ploughing of long term grasslands...), at the edge of some organic rules, leading to good fodder productions but with possible unexpected environmental impacts. This underlines the need for a real conversion of whole agro-food chain including retailers and consumers demand to insure a sustainable conversion of systems turned onto the organic market.

### **Acknowledgements**

We thank the farmers who have accepted to participate to this follow up, the Belgian Federal Scientific Policy (SSTC) and the General Direction of the Agriculture (DGA) of the Walloon Region for funding.

### **References**

- Eriksen J., Askegaard M. and Kristensen K. (1999) Nitrate leaching in an organic dairy crop rotation as affected by organic manure type, livestock density and crop. *Soil Use and Management*, 15, 176-182.
- Granstedt A. (2000) Increasing the efficiency of plant nutrient recycling within the agricultural system as a way of reducing the load to the environment – experience from Sweden and Finland. *Agriculture, Ecosystems and Environment*, 80, 169-185.
- Hennart S., Stilmant D., Lambert R. and Vandenberghe Ch. (2005) Accuracy of the nitrate sampling scheme, proposed in Walloon area, for grazed grasslands. *Proceedings of the 14<sup>th</sup> Nitrogen Workshop*, 24-26<sup>th</sup> October, Maastricht, 144.
- Jamar D. and Stilmant D. (2006) Link between market access and environmental pressure of organic beef productions systems. In : Stassart P., Mormont M., Jamar D., Stilmant D., Aertsens J. and Van Huylenbroeck G. (eds.) How can organic farming contribute to the sustainable production and consumption patterns ? Belgian Science Policy Publisher, 137-158.
- Macilwain C. (2004a). Organic : is it the future of farming ? *Nature*, 428, 792-793.
- Macilwain C. (2004b). Organic FAQs. Is organic farming better for the environment ? *Nature*, 428, 797-798.

# Change in forage practices and technical dialogues among beef cattle farmers in Burgundy

Compagnone C.<sup>1</sup>, Granger S.<sup>1</sup> and Soulard C.<sup>2</sup>

<sup>1</sup> ENESAD, INRA, 26 bd Dr Petitjean, BP 87999, F-21079 Dijon cedex, France

<sup>2</sup> INRA-SAD, 2 place Viala, F-34060 Montpellier cedex1, France

## Abstract

The physical world in which farmers develop their production influences their practices. However, the social environment also influences the way farmers know and think about their practices. In this social environment, the farmers can exchange information and debate technical points of view with each other as well as with a technical consultant to confirm or change their ways of working. We investigated twenty farmers in Burgundy in order to describe how the interactive dialogues in their social network influenced the way they brought about changes in the forage domain.

Three positions were identified: a practical position (what farmers say on their practices in relation to the others), a social position (the position in the social network made of all the farmers being interviewed) and a geographical position (the physical position in a geographical space). Coherence appeared between these three positions and showed that the way farmers choose and analyse their practices, in the forage domain, could be explained geographically and socially. This was particularly true when we looked at the use of wrapping; we noticed the role of some farmers is determined by their position in the social network.

Keywords: social network, interactive dialogues, forage, beef cattle farmers

## Introduction

The social and physical world in which farmers are working constitutes the environment in which: (i) the conception of their practice has historically been generated; (ii) they regularly discuss different points of view, with other farmers or technical advisers, to confirm or to question these practices; (iii) they exchange useful information and advice to improve their know-how. A sociological approach was developed in a multidisciplinary study conducted on beef cattle systems in Burgundy in order to explain the link that could exist between the forage management of farmers and their social world. Our purpose is to analyse the way farmers discuss conceptions and especially those about practice changes with other actors on their geographical area (Compagnone, 2004).

## Materials and methods

Prior to the sociological work, forage management and farmers' practices on grasslands were described on 63 farms (Granger *et al.*, 2007) and 20 farms were chosen located in 4 areas, each equivalent to the size of a canton<sup>2</sup>. Comprehensive interviews were conducted to let farmers: (i) accurately describe the different kinds of grasslands as well as the way they characterize them; (ii) talk about their practices and practice changes. Farmers were questioned on their professional ties to link their practices to professional discussions. We

---

<sup>2</sup> Administrative division of a department (about 2500ha)

drew a social network based on their dialogues that we identified as the social position. We identified a practical position determined from their practices and their relationships with others and we compared it to social position.

To be able to report our argument in detail, we will only present results obtained in a limited geographical area where six farmers were interviewed (canton of Issy-l'Évêque, department of Saône-et-Loire).

**Results and discussion**

*Geographical and social positions: distance and network between farmers*

The professional dialogues of the 6 farmers identified in the surveys can be showed by two sociograms drawing the relations in a geographical area: the first one represents the relationships that connect the interviewed farmers with other farmers (Figure 1), the second one represents the relationships between farmers and their technical advisers (Figure 2). According to the location of partners, two “social relations zones” appeared. They must be understood as the extent of surface area covered by the different links between one farmer and another. These areas corresponded respectively to the south-eastern part of the total area with 3 farmers S4, S5 and S6 and the north-western part with the other three farmers N1, N2 and N3. In the north-western zone, two farmers N1 and N2 were connected through another farmer and an adviser. In the south-eastern zone, the three farmers were partially connected together: through one farmer for S5 and S6, through two advisers for S4 and S5. Indirect specific links are established in each zone between interviewed farmers, while there was no link between the two zones. The south-eastern zone differed from the north-western one in the nature and number of links. Indeed, farmers S4 and S5 had advices either from the agricultural council or supply cooperative, while farmers of the north-western zone had supports from both organisations. Farmers S4 and S6 had fewer relations (3 or 4) with others compared to farmers of the north-western zone (6 or 7). The professional social integration of farmers was less important in the south-eastern zone than in the north-western one. One farmer S5 had more relations than the others in the zone; he seemed to be the intermediary between the other two farmers and with the outside.

Figure 1. Relationships between farmers in the geographical space

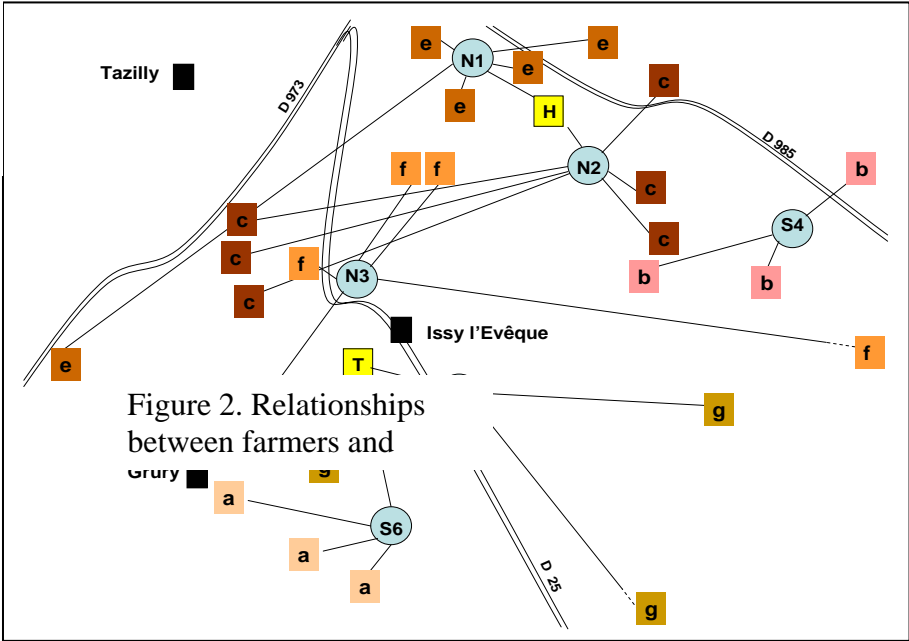
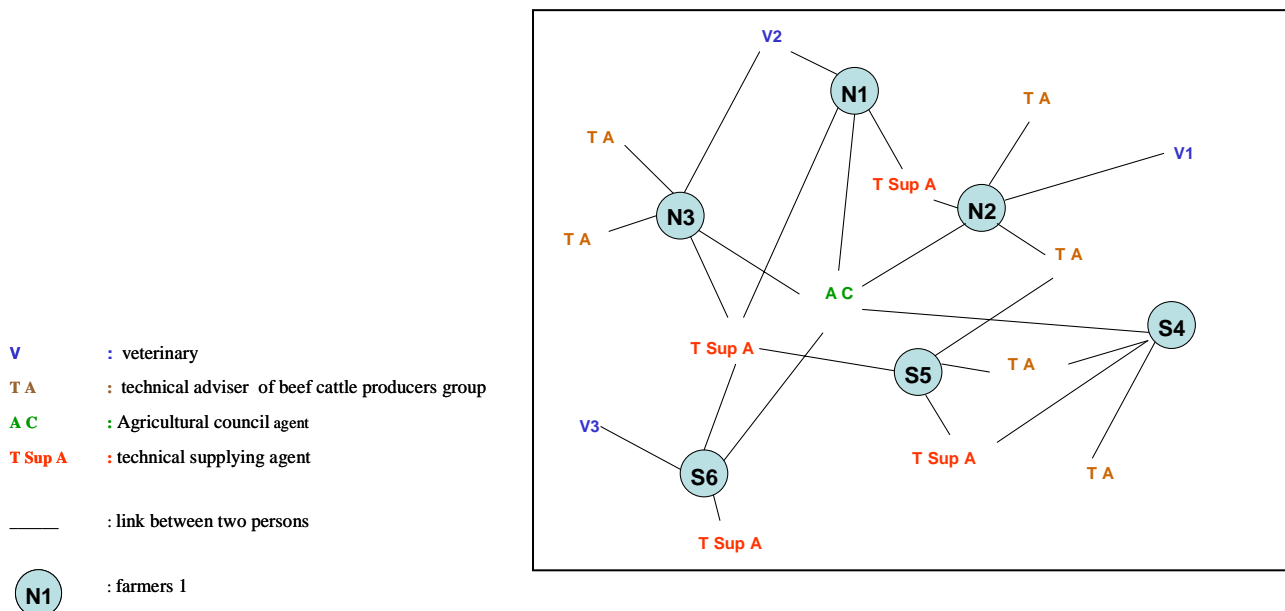

Figure 2. Relationships between farmers and



*Practical position: forage management practices*

According to the forage management practices, we looked at the usual well-established practices or the innovative ones in progress on the farm. Two situations were observed.

In the cluster **usual practices** (UP), two groups could be distinguished by using comprehensive interviews and the typological keys of balance between grazing and harvesting and place of permanent grasslands in the forage management. The first group (UP1) included three farmers (N2, N3 and S6). They prioritised harvesting in their forage management, grazed areas were permanent grasslands only and harvested areas were temporary grasslands. Permanent grasslands "were never ploughed - or a long time ago-"; they never received mineral fertiliser. Fertilisation of temporary grasslands was discussed: farmers said it would be necessary to bring less mineral fertiliser, to use "more traditional" fertilisers although one of them (N2) did not fertilise temporary and permanent grasslands. In the second group (UP2), which was less homogeneous, the harvested areas were permanent grasslands, occasionally for S4 or systematically for S5 and N1 as well as temporary grasslands. Harvested permanent grasslands received mineral fertilisers and were regularly renovated for S4 and N1. Two farmers of this group (S4 and S5) prioritised harvesting and got closer to farmers of group UP1, while N1 prioritised grazing and thus took distance with UP1.

In the cluster **innovative practices** (IP), two topics, forage harvest and grasslands renovation, separated farmers into two groups. Four farmers (N1, N2, N3 and S4) were the first group (IPa): they steadily used wrapping which had gradually replaced silage. N1, N2 and N3 have tested techniques to renovate grasslands: N1 and N2 spoke about an unsuccessful attempt to renovate by direct seeding. N1 and N3 discussed choice of forage varieties of the temporary grasslands that will change in the future so as to get an earlier growth in spring or to make grasslands more resistant to drought. In the second group (IPb), farmers S5 and S6 did not use wrapping and did not test new techniques for grasslands renovation. Two farmers, N3 and S6, were associated to different groups but made silage. This practice placed them close. S5 is more distant from the group IPa than S6.

Coherence between geographical, social and practical positions

What is the coherence between practical positions and social or geographical positions? Regarding the **usual practices** (UP), the superimposition cannot be strictly done; nevertheless some correspondence exists between practical, geographical and social positions. Two farmers (N2 and N3) among the group UP1 (3 farmers) are located on the north-western area; two farmers (S4 and S5) of the group UP2 (3 farmers) are located on the south-eastern area.



Two farmers N1 and S6 showed practices not in coherence with their social position. From a geographical point of view, they were the more distant from the social networks observed in Figure 1. It looks as if the distance to the border made it possible to adopt other practices than those usually used and considered as the standard in the social network they belonged to.

Regarding the **innovative practices** (IP), all farmers of group IPa, except farmer S4, are located in the north-western area and those of group IPb in the south-eastern area. Two farmers, S4 and N3, had practical positions which were not relevant with their social network. S4 used wrapping while farmers in the south-eastern area did not. N3 was the only one to use silage as well as wrapping. From a social point of view, these two farmers were less connected with the farmers of their area (Figure 1), respectively N1 and N2 for N3, S5 and S6 for S4. From their geographical position, they were the nearest to the farmers located in the other area.

Regarding an innovative practice such as **wrapping**, they were less dependent on the standard way of thinking of their zone and more influenced by leading farmers of the other zone. This analysis in terms of geographical space is confirmed by the spread and date of introduction of wrapping from the north-western zone to the south east zone. The farmer N1 considered himself as the pioneer for the use of wrapping in the local area; N2 had used wrapping for 5 to 6 years; N3 and S4 used it more recently. The innovative impulse got from farmer N1, off-centre not only from the whole social network but also from his own zone, at first, to other farmers of the north-western zone, then to farmers of the south-western zone. The farmer S4 introduced wrapping in its own zone (south-western) while N3 used the technique later than the others in his zone (north-eastern). The spreading of wrapping was in accordance with a social and geographical logic well described by the drawing of the two areas (north-western and south-eastern).

## Conclusion

The analysis of the correspondence between the practical position and the social position shows that the way farmers choose and think their practices in the forage domain can be explained geographically and socially. Results depend on the type of practices, usual or innovative, but both correspondences are coherent with each other. For the steady usual practices, border between the two social networks was also a border which divided up practices: farmers from each area used permanent and temporary grasslands in different ways. Nevertheless, difference between practices seems to decrease with the relative distance of the farmer to the border. This suggests, within each area, some diversity in practices and a tolerance of gaps to standard, possibly related to a secondary social network not well identified by our interviews. This social tolerance makes it possible to promote a trend of changes in the network.

## References

- Compagnone C. (2004) Agriculture raisonnée et dynamique de changement en viticulture bourguignonne. In: Conein B., Ferrand A., Lazega E. (dir), *Connaissances et relations sociales, Recherches Sociologiques*, 2004/3, 103-121.
- Granger S., Soulard C., Ingrand S. and Compagnone C (2007) The role of permanent grasslands in the forage system of beef cattle farms in Burgundy. Impacts on the technical needs in the field of forage. *Proceedings of the 12<sup>th</sup> Symposium of the European Grassland Federation, Gent, Belgium*.

# **Breed-specific classification potentials of sheep in different grassland biotopes in the German federal state of Brandenburg**

Fischer A.<sup>1</sup>, Schalitz G.<sup>1</sup> and Behling C.<sup>2</sup>

<sup>1</sup> *Leibniz-Centre for Agricultural Landscape (ZALF) Müncheberg, Germany*

<sup>2</sup> *State Office for Consumer Protection, Agriculture and Land Re-planning Brandenburg, Germany*

## **Abstract**

The political changes in east Germany in the context of German unification had far-reaching consequences for sheep farming in the federal state of Brandenburg.

Most conspicuously, there has been an increasing influx from national and international genetic reservoirs into a region that used to be a main breeding area of a merino breed which was consequently reduced to small groups of remaining stocks.

Due to the new diversity of breeds it is possible to keep sheep at sites with distinct characteristics in a wide range of different biotopes. As cattle and sheep often share the same feed the latter are mainly kept on sandy and low-yield sites which are typical for Brandenburg. There is a considerable variability of distinctive differences between individual breeds. The present paper describes the specifics of the various breeds to be found in Brandenburg and assesses potentials of their employment in different grassland biotopes. This may provide a basis for further studies into genotype-environment interactions which are of practical and economic relevance for reasonable land use by sheep keeping.

Keywords: Sheep, breeding, grasslandbiotope, life-weight

## **Introduction**

Since 1991, the variety of breeds has significantly expanded in Brandenburg. Sheep were imported from all regions in Germany and from all over Europe. However, a study by Baehne (1997) shows that, in some cases, animals were brought to landscapes that did not meet their needs and requirements. As a consequence, often the site-specific preservation target was not achieved, animal production performance dropped, costs increased and, in some cases, farmers gave up and sheep breeding was discontinued.

This paper, therefore, focuses on the question how the new and richer potential of breeds can be used in a more systematic way.

## **Natural site conditions and breed structure**

Brandenburg has some 280,000 hectares of grassland. Sheeps, are mostly herded on low-yield and “other” sites. The latter are, to a considerable extent, grassland sites with a very low productivity index, some of which were formerly used as training areas of the armed forces and are registered in cadastral maps as “not agriculturally used areas”. It is intended to keep these areas open in the future. Management of the greater part of all areas used for sheep herding must comply with conditions issued by the European Union or the governmental authorities of Brandenburg on nature conservation and extensive land use.

Initially influenced by A. D. Thaer, from the 1820s Merino sheep for various specific purposes became the dominating breed.

## Results and discussion

### *Biotope-related plant yields*

The feed quality of grassland crops is largely dependent on plant stand populations and management intensity. Decisive factors in this context are the time and frequency of land use. Table 1 is based on uniform dates for different sites in Brandenburg that are particularly suitable for sheep keeping in this region.

The yield and quality data were supplied from data banks based on results achieved both in experiments and agricultural practice. The values for metabolisable energy (MJ ME kg<sup>-1</sup> DM) are based on raw nutrient contents derived from feed analyses and estimation equations (Weissbach, 1999).

Table 1: Influence of different sites and plant communities on yield (dt/ha DM) and energy concentration (MJ ME/kg DM) under extensive grassland management

Site, moisture and nutrient conditions	Growth	Tussok grass, river-side		Poa-quack grass grassland		Creeping soft-red fescue-poa grassland		Cocksfoot-poa grassland		Red fescue-sheep-fescue association	
		DM	EC	DM	EC	DM	EC	DM	EC	DM	EC
Sand with far groundwater Table (Moisture 4-) (Nutrient A)	1 <sup>st</sup>			9.2	9.8	6.4	9.5	9.6	8.8	4.4	9.2
	2 <sup>nd</sup>			6.6	8.3	4.6	8.0	6.9	9.3	3.2	7.8
	3 <sup>rd</sup>			7.7	8.7	5.4	8.3	8.1	9.2	3.8	8.0
Flood plains. Pleistocene clay and loam soils (Moisture 2-) (Nutrient B)	1 <sup>st</sup>	18.6	10.0	22.2	10.2	11.6	10.2	23.4	9.0	9.0	9.5
	2 <sup>nd</sup>	21.8	8.8	26.1	9.0	13.6	8.8	27.4	9.7	10.5	8.3
	3 <sup>rd</sup>	23.8	8.8	28.3	9.8	14.8	9.0	29.9	9.8	11.5	8.3
Low moors (Moisture 3+) (Nutrient A)	1 <sup>st</sup>	11.5	9.8	13.1	10.3	6.7	10.2	12.9	9.5		
	2 <sup>nd</sup>	13.5	8.7	15.3	9.0	7.8	9.0	15.2	9.7		
	3 <sup>rd</sup>	14.8	8.7	16.7	9.2	8.5	9.0	16.6	9.3		

### *Breed-specific basics for site-related classification of sheep*

There are certain specifics to every breed. They manifest themselves in the living mass, which is closely related to nutritional requirements and thermal balance, in fleece characteristics, digestive physiology, and ethological qualities.

Performance and health decisively depend on the satisfaction of daily dry matter and nutrient requirements. These requirements are, *inter alia*, related to the living mass of the animal concerned. According to Jeroch *et al.* (1999), the intake of dry matter of non-pregnant and in-lamb ewes varies between 1.0 kg and 2.3 kg per animal and day. It increases by 0.5 kg in the lactation period. Drepper and Rohr (1984) reported dry-matter intakes of 2.5 kg to 2.8 kg per 100 kg of sheep. As this source is related to the living mass it is used as a basis on which the intake of dry matter is estimated.

Jeroch *et al.* (1999) stated weight-related energy and crude protein requirements which are based on data of the Society Nutrition Physiology (1996) and the Rostock feed evaluation system. According to them, 430 kJ of metabolisable energy and 4.7 g of crude protein are required for the maintenance (including mean wool yield and locomotive activities) of 1 kg of metabolic living mass ( $W^{0.75}$ ) per day. During pregnancy and lactation the maintenance requirement increases by about 30 per cent to 40 per cent, dependent on single or twin births.

Table 2 shows the requirement values of dry matter, energy and crude protein that result from the above equations with estimations being based on the mean living masses of ewes according to the applicable breeding standards.

Table 2: Estimated dry matter and nutrient requirements of sheep kept in Brandenburg (per ewe and day)

Breed	Living mass	Metabolic living mass	Dry matter intake	Energy maint. requirement	Crude protein requirement
	kg	kg <sup>0.75</sup>	kg*d <sup>-1</sup>	MJ ME *d <sup>-1</sup>	g CP *d <sup>-1</sup>
Suffolk	95	30.4	2.5	13.1	143.0
Blackheaded Mutton	85	28.0	2.3	12.0	131.6
Whiteheaded Mutton	85	28.0	2.3	12.0	131.6
East Friesland Milk	85	28.0	2.3	12.0	131.6
Merino Land	80	26.7	2.1	11.5	125.7
Merino Mutton	78	26.2	2.1	11.3	123.4
Leine	78	26.2	2.1	11.3	123.4
Texel	75	25.5	2.0	11.0	119.8
Bentheim Land	65	22.9	1.7	9.8	107.6
Coburg Fox	65	22.9	1.7	9.8	107.6
Rhon	60	21.6	1.6	9.3	101.3
Gotland	53	19.6	1.4	8.4	92.3
Rough-Haired Pomeranian Land	53	19.5	1.4	8.4	91.7
Grey-Horned Heath	45	17.4	1.2	7.5	81.7
White-Horned Heath	43	16.8	1.1	7.2	78.9
Prong Horn	43	16.8	1.1	7.2	78.9
White Hornless Heath	43	16.6	1.1	7.2	78.2
Skudde	35	14.4	0.9	6.2	67.6

It demonstrates the high degree of variability in the daily requirements of different breeds and indicates both limits and possibilities of their site-related employment.

With an estimated possible dry matter intake on marginal sites of 8.5 to 9.0 MJ ME/dm the maintenance requirement can hardly be met. Furthermore, it is to be expected that feed intake is reduced by another 10 per cent during high summer dryness. At higher temperatures (>28 °C), the thermo-static regulation of feed intake is a limiting factor. It is on the basis of these factors that different sheep breeds may be categorised according to their feed intake abilities in conditions of extensive grassland management. Table 3 demonstrates a respective categorisation of sheep breeds in Brandenburg. It is to be stressed that the estimation result has to be further supported by scientific studies on the relation between feed intake ability and living mass and breed.

Table 3: Categorisation of breeds related to potential feed intake capacity in conditions of extensive grassland management

good	Feed intake capacity	
	average	insufficient
Leine sheep	Merino Mutton sheep	Suffolk sheep
White Hornless Heath sheep	Texel sheep	Blackheaded Mutton sheep
Grey Horned Heath sheep	Bentheim Land sheep	Whiteheaded Mutton sheep
Prong Horn sheep	Coburg Fox sheep	East Friesland Milk sheep
White Horned Heath sheep	Rhon sheep	Merino Land sheep
Skudde sheep	Gotland sheep	Ouessant sheep
	Rough-Haired Pomeranian Land sheep	Soay sheep

Due to their high dry matter and nutrient requirements the employment of heavy commercial breeds for purposes of landscape preservation is possible, though limited. They must be offered additional traditionally managed areas in order to limit more cost-intensive supplementary forage.

The ability of some breeds (*e.g.* German Heath sheep, Bentheim Country sheep) to take in large quantities of feed with high crude fibre contents (Förster and Kneiss, 1999) and to increase their rumen volume can be of practical relevance for landscape preservation. As a result, the feed stays longer in the rumen and the digestibility of organic matter increases. This adaptability is not found with high performance breeds characterised by high growth intensity (Jeroch *et al.*, 1999).

## Conclusions

The greater variety of sheep breeds offers manifold opportunities to keep this animal species on very different grassland sites. Scientific and research efforts should be intensified to improve knowledge on breed-specific nutrient requirements (dry-matter intake, energy and crude protein requirement) and nutrient conversion of land race sheeps in extensive management.

## References

- Baehne T. (1997) Die Lammfleischproduktion im Land Brandenburg unter dem Aspekt einer landschaftspflegenden Schafhaltung. Humboldt University Berlin, Faculty of Agriculture and Horticulture, diploma thesis
- Drepper K and Rohr K. (1984) Grundzüge der Fütterungslehre. Verlag Paul Parey, Hamburg and Berlin
- Förster C and Kneiss P. (1999) Zucht und Landschaftspflege. Deutsche Schafzucht 91, 23, 564-567, Society of Nutrition Physiology 1996. Energie-Bedarf von Schafen. *Proc. Soc. Nutr. Physiol.*, 5, 149-152
- Jeroch H, Drochner W and Simon O. (1999) Ernährung Landwirtschaftlicher Nutztiere. Verlag Eugen Ulmer, Stuttgart
- Weissbach F u. a. (1999) Schätzung der Verdaulichkeit und der Umsetzbaren Energie von Gras und Grasprodukten, *Proc. Soc. Nutr. Physiol.*, 8, 72

# Grassland and its economic use as a renewable energy resource in biogas plants

Hasselmann H. and Bergmann H.

*Department für Agrarökonomie und Rurale Entwicklung, Lehrstuhl für Umwelt- und Ressourcenökonomie, Platz der Göttinger Sieben 5, D-37073 Göttingen*

## Abstract

Global impacts of climate change, the foreseeable end of fossil resources (e.g. oil, coal and uranium) and the upcoming importance of developing countries on global markets like China and India, make it obvious to reconsider climate neutral and regional available energy resources like biomass. This paper analyses if farmers can profitably use biogas plants to process the harvest of meadows and pastures.

It is shown that farmers can play a crucial role in the provision of CO<sub>2</sub>-neutral energies in the production of renewable energies from fields and pastures. With the new legislation from August 2004, the German government supports markedly the use of biomass in biogas plants. By specific farm based calculations for three different sizes of plants (335 kW<sub>el</sub>; 526 kW<sub>el</sub> and 1,7 MW<sub>el</sub>), it is shown that in comparison with maize silage, grasslands (extensively used, nature protected as well as intensively used ones) will play an important role for the future energy supply in Germany. Specific sensitivity analysis in these calculations show that homogenous harvested grass is an absolute necessary prerequisite for a profitable operation of biogas plants.

## Introduction

Actually Europe faces two threats for its future well-being, climate change and dependency on fossil fuels. Those threats are obviously linked by carbon dioxide which undoubtedly is a major cause of climate change and originates to a large proportion from the use of fossil energy as fuels in homes, industry and cars.

Today's western European economies are highly addicted to fossil energy sources. The main sources of energy are primarily imported fossil energy sources mostly from Russia and the Middle East. Since at least the Meadows report in 1973 it is known that fossil energy sources will face out and there is no doubt that this process will be accelerated by

- a) the rise of India's and China's economies and
- b) more important for short term energy prices fluctuations: political instability in the Middle East, Africa and South America.

Besides mostly market based factors influencing the European Energy supply, climate change is a widely accepted threat to Agriculture and the whole European economy. For this reason, the environmental summit meeting in 1992 in Rio with the heading "United Nations Framework Convention on Climate Change" agreed on a goal focused on the "*stabilization of greenhouse gas concentrations in the atmosphere at a level that would prevent dangerous anthropogenic interference with the climate system*" (BUNDESMINISTERIUM DER JUSTIZ 1993, p. 1788). This agreement was signed by 166 countries altogether, thereby making the climate goal an obligatory declaration of intention under the patronage of the United Nations for all signers. The Federal Republic of Germany served as one of the initiators. For years, there was little action taken towards the goals that the agreement from the Rio Summit strived to reach. However, following the Kyoto Conference in 1997, a concrete and obligatory reduction was agreed upon for the first time in which the European

Union as a whole committed itself to reduce emissions by 8% (compared to 1990) and Germany committed itself to reduce carbon dioxide emissions by 20% by 2010. (BUNDESMINISTERIUM DER JUSTIZ 2002, p. 970).

In order to meet these future threats and to change them into future economic development chances the European Union has presented

1. The Biomass Action plan (COM 2005(628))

2. The Biofuels strategy (COM2006(34)).

The Biomass Action plan is the answer of the EU to manage the problems of increasing dependency on imported energy and offers a great opportunity to farmers. By supporting domestic use of biomass for energy production it aims to reduce the dependence on imported energy from 48% to 42% in 2010, to increase the share of renewable energy by 5, to reduce CO<sub>2</sub> emissions (and equivalents) by 209 million tonnes in 2010, to create more than 200,000 jobs in rural areas and to reduce the high oil prices by substitution in 2010. Part of this Action plan is the Biofuel strategy. To support the use of biomass for heating in rural areas Member States may apply reduced rates of VAT. In the framework of the Common Agricultural Policy in 2003 a special aid for energy crops has been introduced (45 €/ha).

### **National calculation bases of the Production of regenerative energy**

In order to be able to fulfil the demand for power and, at the same time, to reach the desired climate protection goals, the German Federal Government decided among other things to promote renewable sources of energy. For this purpose, the law for the priority of renewable energies – EEG (Erneuerbare Energien Gesetz – Law of renewable energy) was issued in 2004 (BUNDESMINISTERIUM DER JUSTIZ 2004, pp. 1918 - 1930). The core of this law is formed by both the power companies' obligation to buy the electricity, as well as by remuneration sets for biomass plant operators. The following sentences are intended for the different plant sizes:

1. to and including an output of 150 kilowatts at least 11.5 cent per kilowatt-hour,
2. to and including an output of 500 kilowatts at least 9.9 cent per kilowatt-hour,
3. to and including an output of 5 megawatts at least 8.9 cent per kilowatt-hour,
4. starting from an output of 5 megawatts at least 8.4 cent per kilowatt-hour.

With the use of regenerating raw materials, the remuneration set rises depending upon the plant around 0.04 to 0.06 EUR in relation to its size and is understood as a major boost in stimulating the interest of farmers to diversify their income by investing into biogas plants. A new operating field for agriculture resulted on this basis, as the number of biological gas facilities rose rapidly with the introduction of the EEG. Especially as with the upcoming Single Farm payments it becomes clearer that farmers will and have recently decreased their livestock (mostly cattle) Germany as well as other European countries are facing a situation in which more and more growth from pastures and meadows is no longer used in husbandry. One possible alternative in Germany is the use of it in Biogas plants. The following calculations present how in comparison with other basic materials like silo maize or potatoes, grassland growth (mostly grass silages) performs economically.

### **The enterprise of biological gas facilities with regenerating raw materials**

The substrates typically used for biological gas facilities in Germany and Austria are presently maize silage and liquid manure. As Maize plantation areas are near to their crop rotation maximum and in some cases the planted area is even beyond e.g. parts of Lower Saxony the question is posed which further substrates can be used from a plant-structural view. In the following text, the use of grass silage will be examined more closely.

If one regards the potential energy (in specific gas yield (l) per kg fresh matter), shows that grass silage can quite be applicable as a substrate as its yield is at least comparable to rye silages and maize silages and quite better than potatoes or even sugar beets.

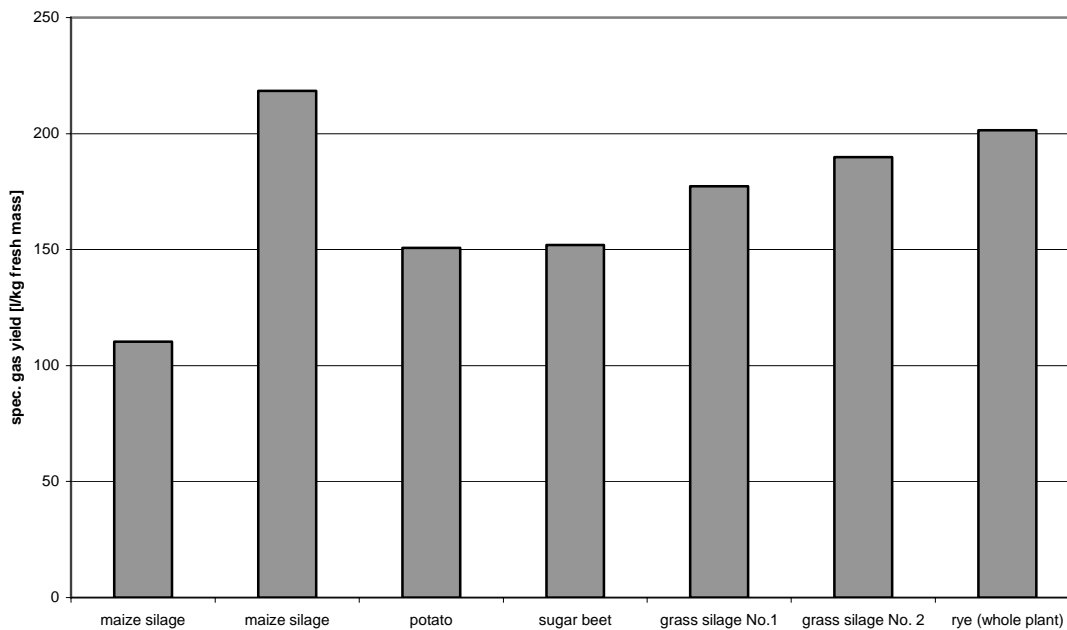

Figure 1: Specific fermentation gas yields of individual substrates (HASSELMANN 2006, p. 53)

The calculations undertaken in this paper are based on a biogas plant model developed by Hasselmann (2006). The main purpose of this model is to analyse the impact of different input substrates on the profitability of the whole plant. The model was extended to test the effect of different substrates in three different biological gas facilities, so as to test the effectiveness of two different sorts of grass silage in comparison with other substrates (HASSELMANN 2006, pp. 35 - 49). Grass silage No. 1 is a upper-grass-stressed silage of the 2-3 cut. The harvest time lies before beginning of the bloom. The grass silage No. 2 is based on same harvest time; in the comparison it is more strongly herb-stressed. The content of dry mass in both silage mentioned is 35%.

This test concerns plant models in the size of 335 kW, 526 kW and 1734 kW electrical rated output. All analysed and presented plants are mesophile wet fermentation plants with continuous filling. For the enterprise 8000 full-load hours per year are assumed. As a basis for the fermentation process, liquid manure from cattle in the proportions of 48%, 53% and 67% are put into the fermentation vat.

For the comparison, the plants with maize silage and two kinds grass silage (grass silage No. 1: upper-grass-stressed; grass silage No. 2: clover and herb-rich) are to be calculated. One subordinates a substrate price of 21.20 EUR/t for maize silage and a substrate price of 20.00 EUR/t for grass silage arises in the following explained profitability's (see Figure 2). The results show that maize silage is naturally the most profitable substrate but that grass silage in both cases can achieve at least 50%.



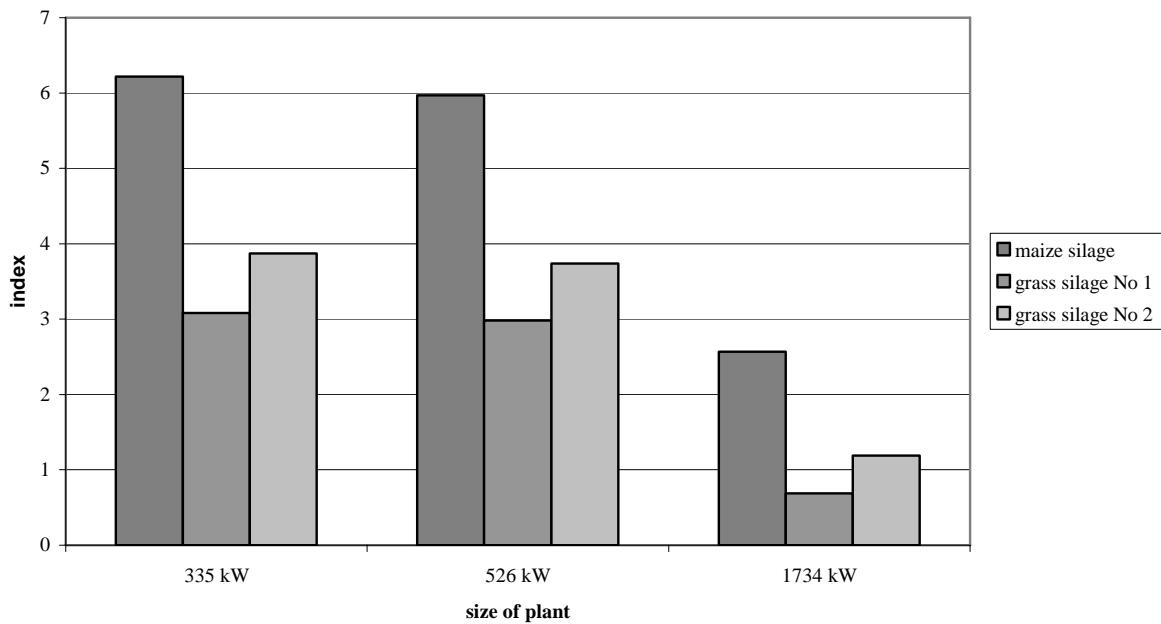

Figure 2: Profitability of the substrates from different plants

## Results and Conclusions

It is shown that the use of grass silage in biological gas facilities is possible in principle, and including especially economic aspects opens a further income opportunity for farmers across Germany and probably beyond. For the fermentation process however, grass silage from agricultural surfaces are to be preferred over those from traffic surfaces. These possess a smaller impurity degree and are available in a nearly constant level of quality. In particular, the grass production here is located on marginal yield locations, and is also accompanied by front running landscape conservation measures.

It can be assumed that, the concentration areas across Germany of biogas plants like in Bavaria and in Lower Saxony will encounter a shortage of available maize substrates. This justifies itself in the small transportation worthiness of the substrates. Especially in these areas, a new business field for grassland enterprises can flourish and can substitute the use of grassland by animal husbandry.

## References

- Bundesministerium der Justiz (Hrsg.) (1993) Bundesgesetzblatt Teil 2 Nr. 33, Bundesanzeigerverlagsgesellschaft mbH, Bonn.
- Bundesministerium der Justiz (Hrsg.) (2002) Bundesgesetzblatt Teil 2 Nr. 16, Bundesanzeigerverlagsgesellschaft mbH, Bonn.
- Bundesministerium der Justiz (Hrsg.) (2004) Bundesgesetzblatt Teil 1 Nr. 40, Bundesanzeigerverlagsgesellschaft mbH, Bonn.
- European Commission (2005) Biomass Action plan, CCOM 2005 (628)  
[http://www.europa.eu.int/comm/energy/res/biomass\\_action\\_plan/doc/2005\\_12\\_07\\_comm\\_biomass\\_action\\_plan\\_en.pdf](http://www.europa.eu.int/comm/energy/res/biomass_action_plan/doc/2005_12_07_comm_biomass_action_plan_en.pdf)
- European Commission (2006) An EU Strategy for Biofuels,  
[http://ec.europa.eu/agriculture/biomass/biofuel/com2006\\_34\\_en.pdf](http://ec.europa.eu/agriculture/biomass/biofuel/com2006_34_en.pdf)
- Hasselmann (2006) Überlegungen zur Rentabilität von Biogasanlagen auf der Grundlage unterschiedlicher Substrate und Voraussetzungen, Göttingen.

# An alternative use of biomass from non-utilised grassland areas

Gonda L.<sup>1</sup> and Gadus J.<sup>2</sup>

<sup>1</sup>*Slovak Agricultural Research Centre - Grassland and Mountain Agriculture Research Institute, Mladeznicka 36, 974 21 Banska Bystrica, Slovakia*

<sup>2</sup>*Slovak University of Agriculture, Faculty of Mechanisation, Tr. A. Hlinku 2, 949 76 Nitra, Slovakia*

## Abstract

A mixture of cattle slurry and preserved herbage from mountain grassland dominated (86%) by *Deschampsia caespitosa* (L.) P. Beauv. was used to produce biogas. Results of trials performed in co-operation with the Slovak University of Agriculture are presented. A semi-continuous experimental equipment was used for biogas production in two cycles from a substrate differing in the proportion of added herbage in the slurry. The substrate composition was analysed, biogas production was measured and conditions of anaerobic decomposition in the fermentor were monitored. These data were submitted to statistical analysis and compared to those recorded at fermentation of slurry without herbage addition. Mean specific production of methane (as m<sup>3</sup>) increased by 9.4% at fermentation of substrate containing 90% slurry and 10% ensiled grass. Fresh herbage was quite unsuitable for the mixture. It was concluded that the mixture of cattle slurry and preserved biomass - mostly poor quality grass - could be utilised for biogas production.

Keywords: biogas, biogas plant, grassland, energy production, analysis

## Introduction

Since 1990, livestock numbers have markedly decreased, namely cattle by 1,023,000 head (65%) and sheep by 279,000 head (46%) in Slovakia, resulting in more areas of non-utilised agricultural land. Currently, this is 240,000 ha (data from the Slovak Land Fund), of which one quarter is permanent grassland (PG) invaded by poor tall grasses, herbs, shrubs and trees. In the non-utilised PG, the proportion of self-sown wood species is 10 – 22%, depending on the period without sward use. This is a big problem for the less-favoured mountain regions where more than 83% of PG is located. The PG areas at slopes of 18° and above are most vulnerable to erosion and avalanche threat. An option for reducing these risk factors is processing the redundant biomass to biogas and to produce energy. As the biogas production depends on the biomass composition, it is important to explore the co-fermentation possibilities and to find the best procedures for cost-effective biogas production. Research on composition of a range of plant and animal waste used for biogas production is presented.

## Materials and methods

The research was conducted in the mountain regions of Slovakia (*Zvolenska* and *Liptovska* hollows and the *Nizke Tatry* mountain range) under operational conditions at five Co-operative Farms (*Ocova*, *Sebedin*, *Micina*, *Smrecany* and *Lipt. Teplicka*). The altitudes ranged between 340 and 1100 m. Total area of investigated permanent grassland was 6,586 ha of which 1,515 ha (23%) were non-utilised swards, as specified in compliance with the official cadastral and aerial maps (orthophotomaps). In total, 10,979 ha of agricultural land were monitored. Botanical composition of swards was determined according to the method of

projective dominance by Regal (1963). Herbage production was determined from 5 samples cut at 50 mm height from 1 m<sup>2</sup>. The arithmetical mean was determined and average yield of herbage per hectare was calculated. Herbage dry matter (DM) was determined in compliance with the Slovak Technical Standard STN 46 0707. Experiments were carried out at the biogas plant which is a part of the Demonstration Farm of the Slovak University of Agriculture. The experimental equipment for biogas production by anaerobic decomposition is shown in Figure 1. The following substrates were processed in the fermentor: i) cattle slurry (100%); ii) cattle slurry (90%) with fresh herbage (10%); iii) cattle slurry (90%) with grass silage (10%); iv) cattle slurry (80%) with grass silage (20%). The parameters measured in the input substrates were as follows: chemical oxygen demand (COD, g l<sup>-1</sup>) photometrically; SO<sub>4</sub> (sulphates, mg l<sup>-1</sup>) photometrically; total nitrogen content (N<sub>tot</sub>, mg l<sup>-1</sup>) photometrically; dry matter content (DM, %) by weighing scales; organic load rate of fermentor (OLR) as kg COD m<sup>3</sup> day<sup>-1</sup> calculatedly. The following parameters were measured in the output substrates: substrate temperature (°C) by a digital resistance thermometer; pH by pH-meter; CH<sub>3</sub>COOH (acetic acid, mg l<sup>-1</sup>) calculatedly. Biogas composition was analysed (*Schmack SSM 60000* analyser) and these four main compounds were measured: CH<sub>4</sub> (methane, % vol.) by infrared two-ray sensor; CO<sub>2</sub> (carbon dioxide, % vol.) by infrared two-ray sensor; O<sub>2</sub> (oxygen, % vol.) electrochemically and H<sub>2</sub>S (hydrogen sulphide, ppm vol.) electrochemically.

## Results and discussion

The botanical composition of swards was diverse and influenced by climatic and environmental conditions – rainfall, slope inclination, soil moisture and particularly by the wide range of altitudes, as shown by long-term records. The proportion of grasses was 35 – 68% (dominated by *Deschampsia caespitosa* L. at 86 %), legumes 5 – 29% and other herbs 18 – 46%. Bare ground varied from 0 to 8%. Yields of DM ranged between 1.56 and 5.94 t ha<sup>-1</sup>. The monitored non-utilised 1,550 ha of PG area produced 26,880 t of fresh biomass (18 % DM) which could provide 2,553,562 m<sup>3</sup> of biogas at production of 95 m<sup>3</sup> t<sup>-1</sup> (Table 1). At 25 MJ m<sup>-3</sup> heating value, annual energy production from biogas is 63.84 TJ.

Table 1. Potential energy production from non-utilised grassland biomass (Gonda, 2005)

Co-op. Farms	Land area (ha)	Biomass yield (t) at DM 18%	Biogas (m <sup>3</sup> )	Heating value (MJ m <sup>-3</sup> )	Thermal energy (TJ)
Ocova	515	9.476	900.220	25	22.51
Sebedin	340	5.559	528.105	25	13.20
Micina	226	2.458	233.472	25	5.81
Smrecany	222	4.409	418.855	25	10.47
Lipt. Teplicka	212	4.978	472.910	25	11.82
Total/Mean	1515	26.880	2.553.562	25	63.84

Moreover, an organic fertiliser is obtained as a secondary product from the processed biomass. Statistically processed experimental data are given in Tables 2, 3 and 4. A comparison of COD at the input substrates showed that ii) substrate contained more organic substances. However, the anaerobic decomposition was less efficient than at i) substrate as shown by decreased biogas production. The mean N<sub>tot</sub> content was also higher with ii) substrate than with i) substrate. The content of DM in ii) substrate fluctuated markedly in relation to the dry matter content of slurry. Substrate samples were analysed to monitor the anaerobic decomposition. The processing temperature at fermentation was within mesophilic limits. The middle value of pH slightly increased with 10% grass silage addition but was not higher than the optimum pH values of 8 – 8.5 reported by Braun (2002). Slurry has a high buffering capacity and high acidity of substrate need not change pH. Consequently, acetic acid content is a better indicator than pH for supervising the process. High content of acetic

acid in iii) substrate was inhibiting the production of biogas (Table 3). Methane content in biogas was higher at processing substrates with ensiled grass than at using only slurry. The content of H<sub>2</sub>S was also below 1000 ppm and biogas could be directly burned without cleaning (Hani, 1998). However, the production of biogas was decreasing with rising proportion of preserved grass.

Table 2. Analyses input and Table output substrates

<i>Input</i>				<i>Output</i>				
Substrates	Parameters	Mean	Min.	Max.	Parameters	Mean	Min.	Max.
i	COD (g l <sup>-1</sup> )	45.5	45.5	72.7	Temperature (°C)	37.5	27.8	43.4
ii		61.5	22.0	95.0		37.7	34.4	42.9
iii		38.3	24.5	48.8		37.9	34.3	42.1
iv		47.8	16.5	89.7		37.8	34.2	39.8
i	Ntot (mg l <sup>-1</sup> )	93.0	93.0	135.0	pH	7.1	6.8	7.8
ii		105.5	31.0	238.0		7.4	7.2	7.6
iii		85.8	47.0	107.5		7.3	7.2	7.4
iv		86.5	20.05	112.4		7.2	7.1	7.3
i	DM (%)	4.8	4.8	7.7	CH <sub>3</sub> COOH (mg l <sup>-1</sup> ) (acetic acid)	-	-	-
ii		5.3	1.4	9.6		2.224.0	600.0	6.300.0
iii		4.3	2	6.0		6.025.0	600.0	19.000.0
iv		4.9	1.1	9.0		2.325.0	600.0	8.400.0
i	OLR as kg	3.2	3.2	5.1				
ii	COD	3.8	1.3	5.7				
iii	(m <sup>3</sup> day <sup>-1</sup> )	2.3	1.5	2.9				
iv		1.85	0.7	3.6				

Table 4. Biogas analysis

Parameters	Substrates	Mean	Minimum	Maximum
CH <sub>4</sub> (% vol.)	i	55.77	53.45	59.10
	ii	56.70	53.40	60.00
	iii	57.09	53.40	61.15
	iv	54.44	52.25	61.20
CO <sub>2</sub> (% vol.)	i	39.07	40.90	43.80
	ii	43.00	40.00	46.50
	iii	40.49	34.45	46.20
	iv	45.55	38.77	47.73
H <sub>2</sub> S (ppm vol.)	i	158.00	0.00	1,672.00
	ii	338.00	14.00	539.00
	iii	227.50	0.00	444.00
	iv	81.00	0.00	375.00
Biogas production (m <sub>N</sub> <sup>3</sup> day <sup>-1</sup> )	i	4.80	0.35	11.02
	ii	3.60	1.21	5.52
	iii	2.64	0.72	4.32
	iv	1.273	0.23	0.55

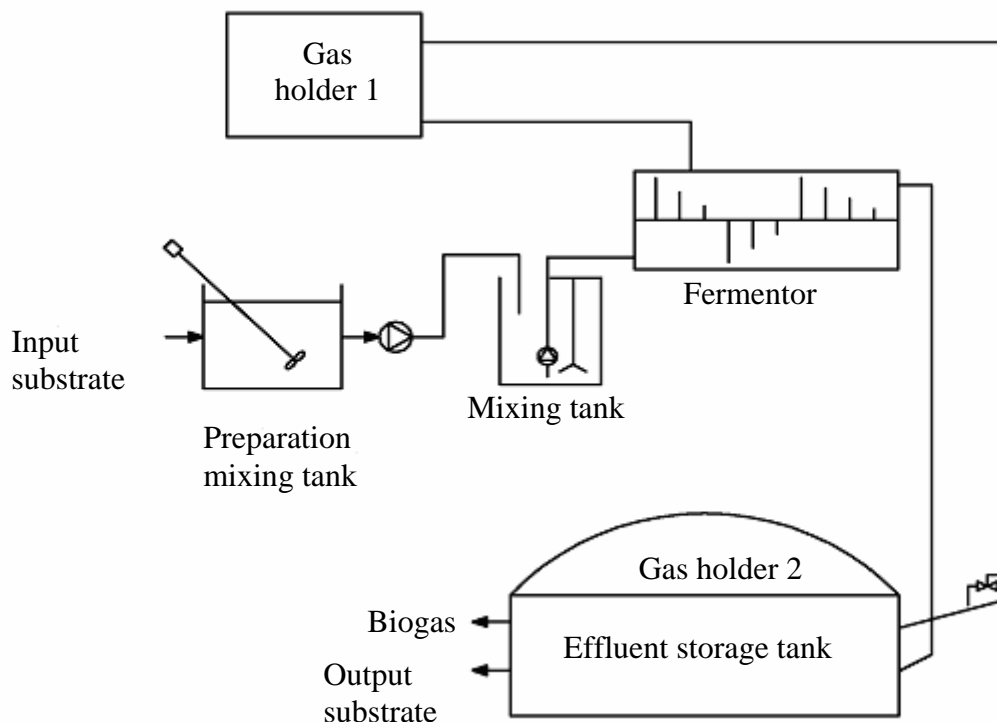

Figure 1. The experimental equipment for biogas production

## Conclusions

The research experiments showed that biomass from non-utilised grassland areas could be processed to produce biogas. A mixture of cattle slurry and ensiled grass was the most efficient input substrate. The mixture of cattle slurry and fresh herbage was not very suitable as a substrate for biogas production by anaerobic fermentation (Sargova, 2005).

## References

- Braun R. (2002) *Anaerobtechnologie für die mechanisch-biologische Vorbehandlung von Restmüll und Klärschlamm*, Wien: BMUJF, ISBN 3-901271-64-3
- Gonda L. (2005) *Energetické zdroje produkcie nevyuzivanych trvalych travnych porastov*. Vyskumna sprava. Banska Bystrica, VUTPHP, 40 pp.
- Hani A. I. (1998) *Untersuchung zu In- und Outputströmen bei der Restabfallvergärung und Vergleich mit der Kompostierung*, Höxter, Universität – Gesamthochschule Paderborn [Diplomova praca]
- Lucke I. (2002) *Biogas. Die regenerative Energie der Zukunft*, Oldenburg: Hochschule Vechta [Diplomova praca]
- Regal V. (1963) *Picninárství*, Praha, SZN, 464 pp
- Sargova S. (2005) *Monitorovanie vplyvu prímеси na energetickú vykonnosť bioplynových zariadení* [Dizertacna praca] Nitra, SPU, 130 pp.

# Two cuts - and afterwards? - Effects of adapted management on permanent grassland

Elsaesser M.

*Bildungs- und Wissenszentrum fuer Viehhaltung, Gruenland, Wild und Fischerei, D - 88326 Aulendorf*

## Abstract

Dairy farmers need grassland forage with very good quality, which can be produced only by intensive grassland use (frequent cuts, high fertilisation). On the other hand farmers mostly have enough or sometimes too much grassland, which gives the impression that there is no need for managing the large areas. What is to do? Using large areas with low intensity only? This seems to be too cost-intensive and the quality is not good enough for feeding dairy cows. On the other hand: Using small areas with higher intensity and no use of the residual grassland? Is mulching the suitable solution?

In an experiment with 4 replications, 4 different grassland management systems have been compared since 2003. Botanical composition, dry matter yields and forage quality attributes are investigated.

Treatments are as follows:

1. Intensive grassland management (5 cuts and 250 kg of nitrogen per ha in total)
2. 2 early cuts with high N fertilisation for 1<sup>st</sup> and 2<sup>nd</sup> cut; after it no further fertilisation; one additional cut in September (120 kg N ha<sup>-1</sup>)
3. 2 early cuts with high N fertilisation for 1<sup>st</sup> and 2<sup>nd</sup> cut; in continuity only mulching at the same time as the last cut in variant 2 (150 kg N ha<sup>-1</sup>)
4. three early cuts and mulching of last regrowth (120 kg N ha<sup>-1</sup>)

The experiment is still going on, only preliminary results can be given.

Keywords: grassland management, cutting frequency, grassland yields, forage quality, botanical composition

## Introduction

High forage quality from grassland is the basis for good nutrition of dairy cows. Therefore there is a need for intensive utilisation with frequent cutting. Caused by a dramatically decrease of the number of milking cows in Baden-Wuerttemberg (South Germany) because of increasing milk performance under the quota system, some parts of grassland area are not used anymore. This had significance for the ecological situation (Briemle and Elsaesser, 1997), f. e. the typical open landscape changes. There is the question, if new forms of grassland management can help to solve the problems with best forage quality on the one hand and the use of large grassland areas at the other. These problems were theme on a grassland conference 2002 in Germany and the present experiment follows this question: Two times cutting and what else?

## Materials and methods

The experiment was established in 2003 on permanent grassland at the experimental station Aulendorf in South Germany (590 m a.s.l., in average 1000 mm annual rainfall and 7 °C mean temperature). Four management treatments were compared using 25 m<sup>2</sup> plots with 4

replications (Table 1). Botanical composition (method according to Klapp (1949)), dry matter yields and forage quality parameters (energy content, crude protein) were investigated. The experiment still persists, so only preliminary results can be given.

Table 1. Treatments

	Treatment	Cutting frequency	Amount and partitioning of N supply (kg ha <sup>-1</sup> )
V1	Control	5 times per year	250 (60/60/60/50/20)
V2	Early cut and harvest	2 early cuts (1 <sup>st</sup> decade in May and 2 <sup>nd</sup> decade in June and late 3 <sup>rd</sup> cut in September)	120 (60/60/0/0/0)
V3	Early cut and mulching	2 early cuts (1 <sup>st</sup> decade in May and 2 <sup>nd</sup> decade in June and late mulching in September)	160 (80/80/0/0/0)
V4	Early cut and mulching	3 early cuts (1 <sup>st</sup> decade in May and 2 <sup>nd</sup> decade in June, end of July and mulching of the last regrowth in October)	120 (60/40/20/0/0)

## Results and discussion

The exceptional drought period in 2003 after the 1st regrowth lead to very low dry matter (DM) yields (Figure 1). Humid weather conditions in 2004 and 2005 increased the yields, whereas 2006 has again lower DM yields, due to the long winter with winter killing of the main grass species *Lolium perenne* and *Lolium hybridum*. However, the 2<sup>nd</sup> and 3<sup>rd</sup> regrowth were stable, the DM yield of the whole year 2006 was lower than that of the years before. Between the treatments significant differences were observed. In wet years, the treatment 1 (five cuts per year), showed best results, whereas in unfavourable years the mulching treatment (var. 3) was highest. The nitrogen yield was much higher than the nitrogen fertilisation. Three early cuts gave higher nitrogen output than only two cuts with the same amount of N fertilizer.

Large differences were observed in net energy contents, with strong decreases in the 3<sup>rd</sup> and 4<sup>th</sup> cut.

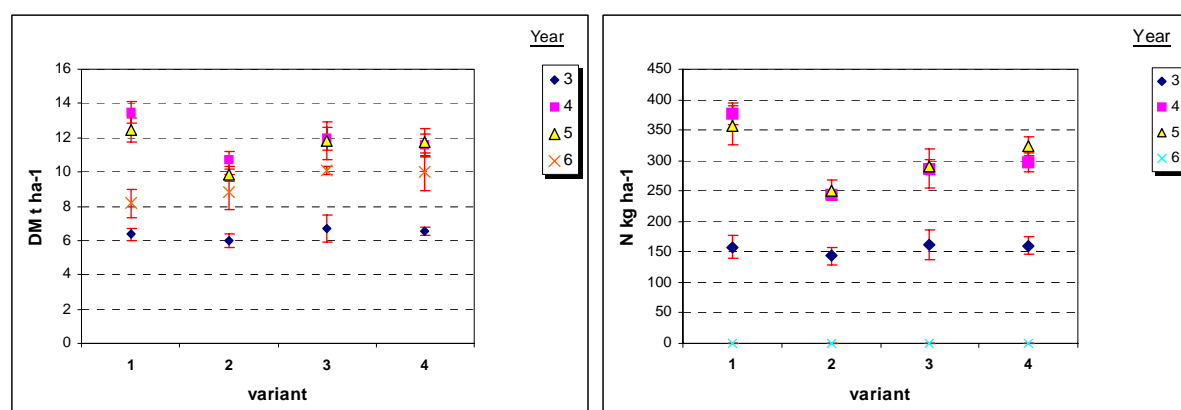

Figure 1. Dry matter yield (2003 - 2006 in t ha<sup>-1</sup>) and N yield (2003 - 2005 in kg ha<sup>-1</sup>) (P<0.05)

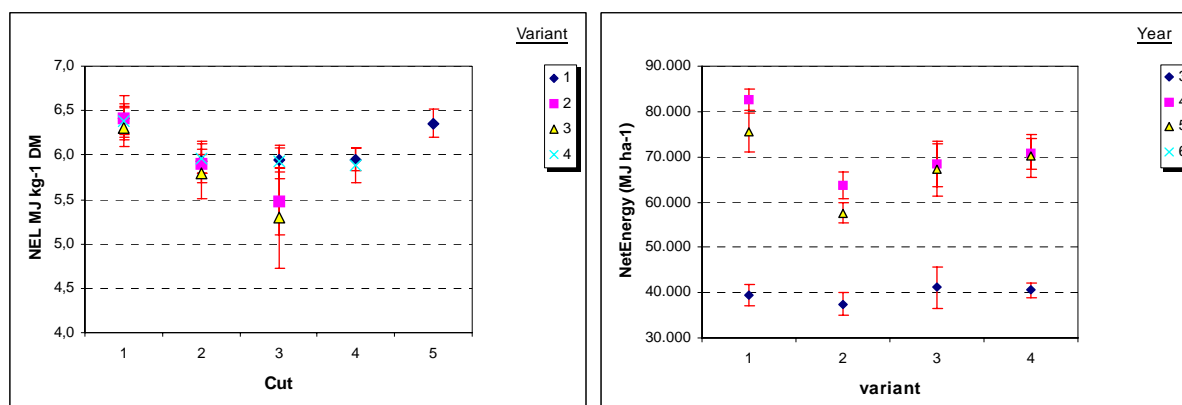

Figure 2. Net energy content (MJ NEL kg<sup>-1</sup> DM) per cut and net energy yield (MJ NEL ha<sup>-1</sup>) (2003 - 2005) (P<0.05)

Concerning the net energy yield, it seems that the reduction of cutting frequency has clear effects. Energy yields were highest with usual management, but three cuts and additional late mulching gave also good results, saving nitrogen and working time for harvests at the same time.

Table 2: mean values of DM and N yields and total net energy (same letters = n.s. P<0.05)

		DM (t ha <sup>-1</sup> )	Energy (NEL ha-1)	N yield (kg ha-1)
treatment	1	10.11 a	65836 a	297.8 a
	2	8.85 b	52910 c	213.0 c
	3	10.15 a	58942 b	246.2 b
	4	9.97 a	60438 b	260.3 b
year	2003	6.41 c	39641 c	156.0 b
	2004	11.93 a	71359 a	301.5 a
	2005	11.47 a	67594 b	305.5 a
	2006	9.27 b		

Caused by the specific grassland management, the botanical composition changed (Table 3). Comparing the first and the last experimental year, the variations in the percentage of grasses and herbs were only marginal, but due to the extreme weather conditions with the exceptional drought in 2003, some grass species show an interesting development. *Poa trivialis* disappeared nearly completely after 2003 and was replaced by *Lolium hybridum*, which could obviously spread by seed. In spring 2006 the conditions changed markedly. Now *Poa trivialis* propagated, whereas *Lolium perenne* disappeared through an infestation with *Fusarium nivale* due to the long winter period with snow until the beginning of April 2006. Differences between the treatments were only small, but it seems that mulching (var. 3 and 4) reduces the percentage of *Taraxacum officinale*.



Table 3. Variation of botanical composition (% of total plant biomass after Klapp, 1949)

Year	03	04	05	06	03	04	05	06	03	04	05	06	03	04	05	06
Treatment	1				2				3				4			
grasses	63	68	61	56	59	68	64	58	63	64	81	59	60	63	73	68
herbs	31	27	29	28	35	28	25	25	33	32	14	28	35	33	16	18
legumes	6	6	10	16	6	5	11	17	5	4	5	14	5	4	11	15
<i>Lolium hybridum</i>	8	23	12	4	8	24	11	3	6	22	27	5	7	20	18	7
<i>Lolium perenne</i>	27	29	21	6	23	23	19	2	25	26	15	3	26	26	17	3
<i>Poa pratensis</i>	4	5	14	18	3	5	16	17	4	5	20	17	4	6	17	20
<i>Poa trivialis</i>	18	2	4	17	19	3	8	18	21	1	7	13	17	2	7	19
<i>Taraxacum officinale</i>	26	23	24	20	29	25	24	19	26	28	13	10	30	27	15	10

## Conclusions

In order to reach best forage quality for dairy production it is necessary to cut grassland very early. If farms have enough or too much land for the nutrition of their dairy herds, it seems better to reduce cutting frequency after the third regrowth with using or discarding the last regrowth. Cutting only twice per year, even if the cutting dates are very early and close to ear emergence, is not enough for good forage quality. At the same time, nitrogen fertilisation can be reduced according to the cutting frequency. The botanical composition after 4 experimental years changed markedly due to the different weather conditions, while herbs have nearly the same percentage over the whole experimental period. If the reduction of the intensity of grassland management is preferable under economical aspects is to be determined in the future under regard of the general framework for agriculture. Cofermentation of grassland in biogas plants seems to be a good alternative to non-using or reduced production intensity.

## References

- Briemle G. and Elsaesser M. (1997) Die Funktionen von Grünland. Berichte über Landwirtschaft, 1, 75, 272-290.
- Elsaesser M. (2002) Zweimal schneiden - und was dann? Tagungsband DLG-Grünlandtagung Bad Hersfeld, 5-8.
- Klapp E (1949) Landwirtschaftliche Anwendung der Pflanzensoziologie. Verlag Eugen Ulmer, Stuttgart.

# Energy use efficiency of grass stands under different management regimes

Kocourková D., Hakl J., Fuksa P., Mrkvička J. and Sobotová H.

*Department of Forage Crops and Grassland Management, Czech University of Agriculture in Prague, Kamýcká 129, 165 21, Prague 6-Suchdol, Czech Republic*

## Abstract

The aim of this research was to find the best grass stand management for energy biomass production from the point of view of energy use efficiency (EUE). The EUE as the ratio of net energy yield to energy input is an important indicator for evaluating the suitability of energy biomass production. The experiment with four grass species (*Festulolium*, *Festuca arundinacea*, *Bromus marginatus* and *Bromus inermis*) grown for biomass production for direct combustion was established in Prague in 2002. The studied treatments were: two cuts with fertilisation (100 kg N ha<sup>-1</sup>), two cuts without fertilisation, one cut at the end of growing season without fertilisation and a delayed harvest in spring without fertilisation. The maximum primary energy yield in average for all treatments was achieved in *B. inermis* plots 92.74 GJ ha<sup>-1</sup> (P < 0.001). The EUE ranged from 7.5 to 34.3 GJ bio energy per GJ input according to grass species and stand management. It was concluded that maximum EUE for observed grasses is in one cut management with harvest at the end of growing season.

Keywords: energy use efficiency, grasses, stands management

## Introduction

Energy resources and their utilization intimately relate to sustainable development. In attaining sustainable development, increasing the energy efficiencies of processes utilizing sustainable energy resources plays an important role (Hepbasli, 2006). Direct combustion is the technology which provides higher energy output than ethanol, oil or biogas production (Stražil, 2000). Only crops that yield significantly more energy than is required to grow them are suitable energy crops, and their potential increase the higher the net energy yields are (Lewandowski and Schmidt, 2006). The productivity, energy input, and costs, as well as environmental impact vary for different energy crops (Börjesson, 1996). Energy balance of biomass production can be influenced among others by choosing crop species and stand management. The one of the indicators that can be used for estimation of energy balance is energy use efficiency (EUE) as the ratio of net energy yield to energy input. The aim of this research was to find the best grass stand management for energy biomass production from the point of view of EUE.

## Materials and methods

The experiment with four grass species (*Festulolium*, *Festuca arundinacea*, *Bromus marginatus* and *Bromus inermis*) grown for biomass production for direct combustion was established at the Czech University of Agriculture in Prague (50°08' N, 14°24' E), 286 m above sea level, in 2002. The experiment comprised of four main treatments: N, two cuts per year with fertiliser (100 kg N ha<sup>-1</sup> applied in the spring as ammonium nitrate) with the first cut at seed ripening (July) and a second cut at the end of the growing season (October); 2S, two cuts per year without fertiliser (July and October); 1S, one cut per year at the end of the growing season (October); J, one cut per year - the delayed harvest until the following spring

(March). The soil in the experimental area was a deep loamy degraded chernozem with a permeable under layer. The area is classified as having a moderate to warm and mostly dry climate. The average growing period is 172 days with a mean annual temperature of 7.9°C (30 year mean) and long-term annual average precipitation of 526 mm. Individual plot size was 10 m<sup>2</sup> and the experimental treatments were established in a randomized block design with four replicates. Primary energy yield was calculated as product from the dry biomass yield and lower heating value (LHV). LHV of biomass was measured using calorimeter LAGET MS 10 A. By subtracting the energy consumption from the energy yield the net energy yield was achieved. The energy input for growing grass was assessed according to energy coefficients stated in Preininger (1987), Nagy (1999) and Strašil (2000). The energy input of phosphorus (40 kg ha<sup>-1</sup> per year in superphosphate) and potassium (100 kg K ha<sup>-1</sup> per year in KCl) application was included although it was not used because of sufficient soil nutrient reserve. The energy use efficiency (EUE) was obtained as the output: input ratio of the primary energy yield and energy consumption. An analysis of variance was carried out on the variables for primary energy yield, energy consumption and EUE.

## Results and discussion

Energy consumption was highest at the plots with N fertilisation. It is caused by high energy demand for the production of N fertilisers (e.g. Preininger, 1987, Strašil, 2000, Lewandowski and Schmidt, 2006) and due to increase of biomass yields and consequently higher energy input for harvesting (Table 1).

Table 1. Energy input for the production of grass biomass under different stand management

Operation	Energy consumption (GJ ha <sup>-1</sup> year <sup>-1</sup> )				Data source
	N	2S	1S	J	
Soil preparation	0.547	0.547	0.547	0.547	Strašil (2000)
Fertilisation	9.611	1.284	1.284	1.284	Preininger (1987)
Sowing	0.211	0.211	0.211	0.211	Strašil (2000)
Harvest*	0.881	0.720	0.392	0.294	Preininger (1987). Nagy (1999). Strašil (2000)
Total	11.25	2.762	2.434	2.336	

\* average for species

The differences in energy consumption for growing different grass species were small but significant (Table 2) and they were caused by different level of biomass yield and consequently diverse energy input for harvesting.

Primary energy yield was significantly influenced by grass species and stand management (Table 2). The highest average primary energy yield was assessed in *B.inermis* plots (92.74 GJ ha<sup>-1</sup>) and in treatment N (117.18 GJ ha<sup>-1</sup>). Our results show, that growing of the selected species provides lower primary energy yield than is usually achieved with growing of more common energy grasses like *Phalaris arundinacea* and *Miscanthus* (Strašil, 2003, Lewandowski, 2006). Adverse energy balance can be ascribed to unsuitable stand management of studied species and varieties which were bred for forage production it means for on the average three cuts regime. Delayed first harvest and only one or two cuts per year decreased total biomass yield and consequently the primary energy yield was lower.

Similar to our results, Lewandowski and Schmidt (2006) concluded that EUE decreases with increasing N fertiliser rates. Energy use efficiency was lowest in N fertilised plots where ranged from 7.72 to 14.04 GJ per GJ energy input in *Festulolium* and *B. inermis*, respectively. The effect of treatment on EUE was significant (P < 0.0001).

Table 2. Effect of grass species and treatment on energy consumption, primary energy yield and energy use efficiency (EUE)

Factor		Energy consumption (GJ/ha)	Primary energy yield (GJ/ha)	EUE (GJ <sub>output</sub> /GJ <sub>input</sub> )
Grass species	<i>Festulolium</i>	4.61a	60.49a	15.92a
	<i>F.arundinacea</i>	4.63a	66.04ab	17.35a
	<i>B.marginatus</i>	4.66b	76.19bc	21.85b
	<i>B.inermis</i>	4.72c	92.74d	22.34b
	p-value	0.0003	0.0000	0.0000
	F test	6.57	19.89	21.17
Treatments	N	11.17a	117.18a	9.41a
	2S	2.68b	66.83b	23.95b
	1S	2.44c	67.40b	26.34b
	J	2.34d	44.06c	17.77c
	p-value	0.0000	0.0000	0.0000
	F test	58870	92.08	117.79

Means followed by the same letter are not significantly different at  $P < 0,01$  (Scheffe)

N - two cuts per year with fertiliser; 2S - two cuts per year without fertiliser; 1S - one cut per year at the end of the growing season; J - one cut per year - the delayed harvest until the following spring

The grass species response to management types were similar with the highest energy consumption and primary energy yield on twice cut fertilised plots and the lowest in the one spring harvest system. Harvest in spring is from the point of view of EUE less favourable because of biomass losses during winter months. *B. inermis* and *B. marginatus* provided higher EUE than *F. arundinacea* and *Festulolium* (Table 2) which indicate the importance of species choice.

## Conclusion

*B. inermis* provided the highest primary energy yield and EUE. In spite of the fact, that in fertilised plots was obtained significantly more energy in harvested biomass in comparison with other management regimes, one cut treatment with autumn harvest was evaluated as the most suitable stand management for studied grass species on the base of EUE.

## Acknowledgement

This research was supported by Research Project of Ministry of Education, Youth and Sports of Czech Republic No. 6046070901.

## References

- Börjesson P.I.I. (1996) Energy analysis of biomass production and transportation. *Biomass and bioenergy*, 11, 4, 305-318.
- Hepbasli A. (2006) A key review on exergetic analysis and assessment of renewable energy resources for a sustainable future. *Renewable and Sustainable Energy Reviews*, In Press, Corrected Proof, Available online 27 November 2006 (<http://www.sciencedirect.com/science/article/B6VMY-4MFCS3R-1/2/98a2e9e9b10382370cd6b22a4d1e42ad>)
- Lewandowski I. and Schmidt U. (2006) Nitrogen, energy and land use efficiencies of Miscanthus, reed canary grass and triticale as determined by the boundary line approach. *Agriculture, ecosystems and environment*, 112, 4, 335 - 346.
- Nagy C.N. (1999) Energy coefficients for agriculture inputs in western Canada. CAEEDAC, 41 pp.
- Preininger M. (1987) Energetické hodnocení výrobních procesů. Metodika Mze, Praha, 29 pp.
- Stražil Z. (2000) Energetické hodnocení vybraných klasických a netradičních alternativních plodin jako zdroje různých energetických paliv. In: Kalorimetrický seminář 2000, 29. 5. - 1. 6. 2000, Zvíkovské Podhradí, pp. 49 - 53.

# Energy potential of reed canary grass as an energy crop in organic agriculture in Lithuania

Kryzeviciene A.<sup>1</sup>, Navickas K.<sup>2</sup>, Venslauskas K.<sup>2</sup> and Zuperka V.<sup>2</sup>

<sup>1</sup>Department of Plant Nutrition and Agroecology, Lithuanian Institute of Agriculture, Akademija, LT-58344, Kedainiai distr., Lithuania

<sup>2</sup>Department of Agroenergetics, Lithuanian University of Agriculture, Studentu 11, LT-53356, Akademija, Kaunas, Lithuania

## Abstract

The present paper provides the results on the energy potential of the swards composed of pure reed canary grass (*Phalaris arundinacea* L.) and its mixtures with legumes (*Galega orientalis*, *Lupinus polyphyllus*, *Melilotus officinalis*) grown for biogas production. The experimental evidence suggests that sward species composition and timing of the 1<sup>st</sup> cut exerted some effect on biomass yield. All swards, irrespective of the species composition, were higher yielding in the 1<sup>st</sup> cut, especially when it was taken in July. The total annual dry matter (DM) yield of two cuts for more productive swards exceeded 9 t ha<sup>-1</sup>.

The highest biogas yield from the biomass of perennial grasses was produced from the second cut. The results show a large variation in the potential for bio-energy (biogas) of different swards, ranging from 52 to 138 GJ ha<sup>-1</sup>. The two swards, mixture of reed canary grass with goat's rue and pure reed canary grass, had the greatest energy potential -138 and 130 GJ ha<sup>-1</sup>, respectively. In all cases organically grown mixtures had an important advantage over pure swards applied with nitrogen.

Keywords: *Phalaris arundinacea* L., energy potential, biomass, biogas

## Introduction

In developed and relatively densely populated areas as occur in Northwest and Central Europe, surplus land (i.e. surplus relative to food production) is likely to go into integrated production of non-food crops, amenity and environment – ameliorating activities (Askew, 2005). Such a trend would offer new opportunities for grassland species.

Cultivating perennial grasses for energy purposes in Lithuania will enable us to harness the arable lands that are now standing fallow (currently about 0.5 million ha) and will reduce reliance on the imports of fossil fuels. The researchers of biomass in the US and Europe concluded that the most important perennial rhizomatous grasses (PRG) for energy crops can be grasses with either the C<sub>3</sub> and C<sub>4</sub> photosynthetic pathway, but in more likely cool regions the most promising grass is reed canary grass (C<sub>3</sub>) (Lewandowski *et al.*, 2003; McLaughlin and Walsh, 1998; Olsson and Landström, 2000). The results from Finland show that experimental biomass yield on organic soils was of 8-14 t DM ha<sup>-1</sup> (Sahramaa *et al.*, 2003), on mineral soils 5-8 t DM ha<sup>-1</sup> (Venendaal *et al.*, 1997).

The aim of the present study was to test the energy potential of different swards using their production for non-food, i.e. for biogas production.

## Materials and methods

In the field experiments conducted during 2000-2004 reed canary grass was tested in pure-sown stands and in mixtures with legumes. The soil of the experimental site is characterised as *Endocalcari – Epihypogleyic Cambisol*, light loam. Soil pH varied between 5.2-7.0, humus content was 1.5-1.9%, available P<sub>2</sub>O<sub>5</sub> 150 mg kg<sup>-1</sup> and K<sub>2</sub>O 169 mg kg<sup>-1</sup>. The trials were set up in 2000 with a net plot size of 10 m<sup>2</sup>. The plots were arranged in one row and replicated four times. The pure swards of grasses were fertilized with 120 kg N ha<sup>-1</sup> split-applied in two equal applications: in spring and after the first cut. Three two-component mixtures were composed of reed canary grass and a legume: the first mixture (Mix-1) with sweet clover (*M. officinalis*), the second mixture (Mix-2) with perennial lupine (*L. polyphyllus*) and the third mixture (Mix-3) with goat's rue (*G. orientalis*). All mixtures did not receive any nitrogen fertilisation. The yield presented in the article is from two cuts per season: in Experiment 1 (Exp 1) the first cut was taken in the middle of June and in Exp 2 in the middle of July, the second cut in both Exps was taken simultaneously at the end of September. On the cutting day the cut herbage biomass was weighed and sampled for DM content determination.

The yield data were statistically processed using the analysis of variance. Energy potential (E<sub>A</sub>) of swards was calculated according to the herbage DM yield and biogas yield (B<sub>DM</sub>), extracted from biomass on laboratory scale digesters. Biogas energy value was estimated according to methane concentration in biogas. The data on the characteristics of grass biomass for biogas production are comprehensively analysed and discussed in Navickas *et al.* (2003).

## Results and discussion

Species composition of the swards and timing of the 1<sup>st</sup> cut had some effect on the annual biomass yield. DM yield of the 1<sup>st</sup> cut was higher for pure reed canary grass, than that for mixtures, when the swards had been cut in June (in Exp 1), 5.93 t ha<sup>-1</sup> (Table 1).

Table 1. Dry matter yield (t ha<sup>-1</sup>) of *Ph. arundinacea* sown pure and in mixtures with legumes

Composition of swards	DM yield t ha <sup>-1</sup>					
	Experiment 1 (Exp 1)			Experiment 2 (Exp 2)		
	1 <sup>st</sup> cut in June	2 <sup>nd</sup> cut in September	Total	1 <sup>st</sup> cut in July	2 <sup>nd</sup> cut in September	Total
Pure sward, N <sub>60+60</sub>	5.930	3.353	9.283	6.880	2.457	9.337
Mix-1 (with <i>Melilotus officinalis</i> )	3.993	1.890	5.883	5.060	1.250	6.310
Mix-2 (with <i>Lupinus polyphyllus</i> )	4.360	2.003	6.363	5.917	1.503	7.420
Mix-3 (with <i>Galega orientalis</i> )	4.833	2.217	7.050	6.950	2.130	9.080
LSD <sub>0.05</sub>	0.2677	0.0973	0.2848	0.2704	0.0575	0.3529

The lowest and non-significant differences in biomass yield were between pure grasses and their mixtures with *G. orientalis* Mix -3 in the first cut in both experiments.

Our findings suggest that when the first cut had been taken later, the biomass of the first cut of swards increased from 0.95 to 2.12 t ha<sup>-1</sup>, irrespective of the species composition. The data of the annual yield indicates that the timing of the 1<sup>st</sup> cut exerted a lesser effect on pure grass swards with N than on mixtures. Due to nitrogen fertilisation, pure grasses grew and yielded more stably than mixtures. Despite the differences in biomass, the early-cut swards had more chances to produce a more abundant aftermath or yield of the 2<sup>nd</sup> cut. In Exp 1 DM yield of

aftermath was higher than in Exp 2. In the latter experiment the annual DM yield was much higher of all mixtures, compared with Exp 1: the total yield increase of mixtures Mix-1 amounted to 0.43 t ha<sup>-1</sup>, of Mix-2 – to 1.06 and of Mix-3 – to 2.03 t ha<sup>-1</sup>.

Biogas yield ( $B_{DM}$ , m<sup>3</sup> kg<sup>-1</sup>) was significantly higher from the aftermath herbage mass, (0.527-0.790) than that from the 1<sup>st</sup> cut mass (0.326-0.678) (Table 2).

Table 2. Biogas production from biomass of perennial grasses

Composition of swards	Biomass of 1 <sup>st</sup> cut in June			Biomass of 2 <sup>nd</sup> cut (aftermath) in September			Total energy potential
	$B_{DM}$ (m <sup>3</sup> kg <sup>-1</sup> )	CH <sub>4</sub> (%)	$E_A$ (GJ ha <sup>-1</sup> )	$B_{DM}$ (m <sup>3</sup> kg <sup>-1</sup> )	CH <sub>4</sub> (%)	$E_A$ (GJ ha <sup>-1</sup> )	$E_A$ (GJ ha <sup>-1</sup> )
Pure swards	0.579	68.0	88.97	0.614	65.0	40.90	129.87
Mix-1	0.326	62.1	32.23	0.551	64.4	19.65	51.99
Mix-2	0.473	65.3	56.00	0.527	63.1	20.57	76.57
Mix-3	0.678	70.2	98.94	0.790	63.8	38.66	137.59

The content of methane (CH<sub>4</sub>) in the biogas produced from the biomass of the 1<sup>st</sup> cut ranged from 62 to 70%, and that in the biomass produced from aftermath 63-65%. The highest energy potential ( $E_A$ ) was estimated for the pure *Ph. arundinacea* and for mixtures Mix-3, 89 and 99 GJ ha<sup>-1</sup>, respectively. The amount of gas produced from aftermath was 20-41 GJ ha<sup>-1</sup> and in the total energy yield it constituted a higher percentage than DM yield. As a result, aftermath biomass was characterized by a higher gas yield. The highest total annual energy potential 130-138 GJ ha<sup>-1</sup> was obtained from pure sward of *Ph. arundinacea* and from mixtures Mix-3.

## Conclusions

Pure *Phalaris arundinacea*, applied with N<sub>60+60</sub> yielded significantly best of the four swards differing in species composition grown on a light soil, low in humus (up to 2%) only when 1<sup>st</sup> cut had been taken in June. The total yield of pure stand and mixtures with *Galega orientalis* Mix -3 was not significantly different when 1<sup>st</sup> cut had been taken in July. Averaged annual DM yield amounted to 9.2 t ha<sup>-1</sup>.

The biomass of 1<sup>st</sup> cut of Mix -3 was higher when the cut was taken later (in July), but the annual biomass yield of these mixtures practically did not differ from that of pure grass sward. This suggests that the legumes supplied the swards with biologically-fixed nitrogen and this is an important advantage of mixtures over pure stands in organic agriculture. Moreover, this is a good perspective in reducing nitrogen costs.

The highest biogas yield (up to 0.79 m<sup>3</sup> kg<sup>-1</sup>) from biomass of swards was produced from the 2<sup>nd</sup> cut (aftermath).

Pure *Phalaris arundinacea* and its mixtures with *Galega orientalis* were found to have the greatest energy potential, 130-138 GJ ha<sup>-1</sup>, of the four swards differing in species composition, whose biomass was used for biogas production.

## References

- Askew M.F. (2005) The potential of grassland and associated forages to produce fibre, biomass, energy or other feed stocks for non-food and other sectors: new uses for a global resource. In: McGilloway D.A. (ed.) *Grassland: a global resource*. Wageningen Academic Publishers, The Netherlands, 179-188.
- Lewandowski I., Scurlock J.M. and Lindvall E., (2003) The development and current status of perennial rhizomatous grasses as energy crops in the US and Europe. *Biomass and Bioenergy*, 25, 335-361.
- Navickas K., Zuperka V. and Janusauskas R. (2003) Utilisation of perennial grasses for biogas generation. *Agricultural Engineering*, Research papers, 35(4). Raudondvaris, 109-116. (in Lithuanian).
- McLaughlin S. and Walsh M.E. (1998) Evaluating environmental consequences of producing herbaceous crops for bioenergy. *Biomass and bioenergy*, 14, 17-24.
- Olson R. and Landstrom S. (2000) Screening trials with new breeding lines of reed canary grass (*Phalaris arundinacea*) under development for varieties for energy and industrial use in Northern Europe. *Final Conference of Cost Action 814, Crop Development for the cool and wet regions of Europe* (Patente G., Frame J., eds). Pordenone, Italy.
- Sahramaa M., Ihamaki H. and Jauhiainen L. (2003) Variation in biomass related variables of reed canary grass. *Agricultural and Food Science in Finland*, 12(3-4), 213-225.
- Venendaal R., Jorgensen U. and Forsters C.A. (1997) European energy crops: a synthesis. *Biomass and Bioenergy*, 13(3), 147-185.



## Index of Authors

Adamovich A.	59, 181	D'Ottavio P.	204
Adamovicha O.	181	Da Ronch F.	548
Andueza D.	200	Daugeliene N.	102
Argenti G.	291, 386	Dax T.	488
Argüello-Montserrat E.	263	De Vliegheer A.	1, 51
Arlauskienė A.	331	Debersaques F.	142
Avraam E.M.	371	Decruyenaere V.	279, 351
Baert G.	142	Demolder H.	414
Baert J.	86	Denef K.	259
Balcar J.	287	Dessein J.	484
Bałuch-Małecka A.	150	Destain J.-P.	327, 351
Baret P.V.	560	Dettori D.	43
Barszczewski J.	114	Di Grigoli A.	208
Bartolomé J.	406	Di Leo V.	386
Baumgartner D.	382	Di Miceli G.	208
Baumont R.	200	Di Prinzio M.	386
Behling C.	568	Diack I.A.	516
Bergamini A.	496	Dijkstra J.	540
Bergmann H.	488, 572	Dimitrova Ts.	134
Bernard F.	189	Dittert K.	319
Besnard A.	335	Domingo Olivé F.	267
Black A.D.	192, 215	Dovier S.	480
Blaj V.	94	Dragomir C.	185
Boeckx P.	259, 263	Dragomir N.	185
Bolognesi L.	386	Dufrasne I.	323, 343, 375
Boltshauser A.	496	Elgersma A.	162, 540
Bommelé L.	1	Elsaesser M.	580
Bonanno A.	208	Eriksen J.	212, 219
Bonis A.	173	Fefeu B.	200
Bottecchia C.	480	Fernagut B.	307
Bouzillé J.-B.	173	Fernández-Núñez E.	508
Bovolenta S.	480	Fiala J.	398
Bries J.	142	Fischer A.	568
Briner H.U.	417	Franca A.	43
Britanak N.	367, 378	Fratila I.	185
Bubenheim H.	259	Freiermuth Knuchel R.	382
Buchgraber K.	532	Frelich J.	223
Burs W.	114, 556	Fretté X.C.	212, 219
Butkutė B.	158	Froidmont E.	351
Butkute R.	102	Fuksa P.	584
Butkutė R.	118, 355	Fustec J.	189
Butkuvienė E.	118	Gadus J.	576
Butler M.R.	315	Gaillard G.	382
Butnariu M.	524	Gaisler J.	126, 398
Cabaraux J.-F.	323, 343, 375	Gaman L.	185
Carlier L.	1, 51, 90	Gaspar S.	185
Cecato U.	200	Genghini M.	386
Čermák B.	223	Giambalvo D.	208
Cervasio F.	386	Gierus M.	27, 82, 162
Chambaut H.	492	Gilliland T.	66
Compagnone C.	476, 564	Godden B.	327
Connolly J.	421	Golińska B.	196
Cunderlik J.	367	Goliński P.	196, 504
		Gonda L.	287, 576
		Gottwaldová P.	394
		Grabowski K.	63

Grandchamp A.-C.	496	Katova A.	86
Granger S.	476, 564	Kauer K.	339
Griesebner C.	138	Keller Ch.	496
Grünhage L.	425	Kexagia A.	371
Grünig A.	271	Kirilov A.	15
Grzegorzczak S.	63	Knoden D.	327
Gutkowska A.	441	Kocourková D.	584
Gutmane I.	59	Kohoutek A.	39, 90, 398, 536
Haesaert G.	142	Komárek P.	39, 90, 398
Hakl J.	584	Köster T.	339
Haková P.	223	Kostopoulou P.	429
Halling M.	27	Kovács P.	283
Hanocq D.	335	Kozłowska T.	299
Hanzes L.	378	Kozłowski S.	196
Harkot W.	433, 500	Krautzer B.	532
Hasselmann H.	572	Kreuzer M.	162
Hatch D.	227, 472	Kristensen I.S.	311
Hejcman M.	512	Kristensen T.	212, 219, 311
Hejduk S.	177	Kryszak A.	410
Hennart S.	279, 351	Kryszak J.	410
Hennessy T.	445	Kryzeviciene A.	587
Hermann A.	82, 463	Kulakovskaya T.	130
Hermenean I.	94	Kwiecień R.	299
Hofmann M.	303	Kyriazopoulos A.	437
Hofstetter P.	496	Laidinen G.	130
Holm Nielsen J.	212, 219	Lambert R.	323
Hopkins A.	27, 170, 472, 544	Larionova N.	130
Hornick J.-L.	323, 343, 375	Látal O.	70
Hovorka G.	488	Laurent F.	227, 335
Hrabě F.	398	Lauwers L.	307
Hristov K.	86	Le Gall A.	492
Huguenin-Elie O.	382	Lenhart K.	259, 263
Hurley G.	66	Ligabue M.	347
Iacob T.	146, 528	Lipińska H.	433, 500
Ilavská L.	378	Liptak L.	378
Ionescu I.	110	Lobley M.	544
Isselstein J.	303	Lobsiger M.	74
Istasse L.	323, 343, 375	Loges R.	162, 319
Jäger H.-J.	263, 425	Loiseau P.	227
Jakešová H.	398	López-Díaz M.L.	154
Jamar D.	560	López-i-Gelats F.	406
Janicka M.	98	Lösche M.	82
Jankowska-Huflejt H.	556	Lüscher A.	74, 417, 421
Jeangros B.	74	Luxen P.	327
Jeanneret Ph.	382	Macháč R.	177
Jewkes E.C.	315, 472	Macolino S.	548
Kacorzyk P.	359	Maikštėnienė S.	331
Kádár I.	283	Malda K.	540
Kadžiuilienė Ž.	47	Mandaluniz N.	275
Kadžiulis L.	47	Mantovi P.	347
Kammann C.	263, 425	Martincova J.	287
Karakosta C. C.	122	Marusca T.	94
Karameri E.	371	Mary B.	335
Karatassiou M.	371	Meduna E.	496
Kašparová J.	394, 398	Mertens J.	142
Kasperczyk M.	359	Messeri A.	291

Meul M.	484	Rigueiro-Rodríguez A.	154, 508
Meura S.	323, 343, 375	Röder N.	445, 496
Mičová P.	398	Rodrigues A.	200
Mihaescu L.	185	Roselló Martínez A.	267
Mocanu V.	94	Rosická L.	398
Moisuc A.	524	Rosignol N.	173
Moloney A.P.	215	Rost M.	223
Mosimann E.	74	Rotar I.	15, 295, 363
Mosquera-Losada M.R.	154, 508	Röver K.-U.	303
Mrkvička J.	584	Ruiz R.	275
Müller C.	259, 263, 425	Ruoss E.	496
Murray P.J.	247	Sacconi F.	386
Nagy G.	78	Şahin Demirbağ N.	303
Nannen D.U.	319	Salama H.	82
Navickas K.	587	Salvia Fuentes J.	267
Nemecek Th.	382	Samuil C.	146, 528
Neružil P.	39, 90, 398	Santilocchi R.	204
Nesheim L.	55	Sărăţeanu V.	524
Nevens F.	484	Sarbu A.	185
Nicolardot B.	335	Schalitz G.	568
Noitsakis B.	429	Scheidegger Ch.	496
O'Donovan M.	66	Schellberg J.	512
O'Kiely P.	192, 215	Schmid W.	271
Odstrčilová V.	39, 90, 398	Scholefield, D.	315
Olszewska M.	150	Schüpbach B.	271
Ondrasek L.	287, 367	Selge A.	339
Oregui L.M.	275	Serafimov P.	134
Osiceanu M.	110	Serra Gironella J.	267
Overloop S.	307	Ševčíková M.	394
Pácurar F.	363	Siegrist-Maag S.	421
Papanastasis V.P.	122	Sienkiewicz-Pad. D.	520
Paplauskienė V.	158	Sima N.	295
Parente G.	480	Six J.	263
Parissi Z.M.	371	Šlachta M.	223
Pasut D.	480	Smeding F.W.	247
Pavlů V.	126	Smit H.J.	162, 540
Pazzi G.	291	Sobotová H.	584
Peel S.	516	Søgaard K.	27, 166, 212, 219
Pelikán J.	177, 394	Sölter U.	170
Pet E.	185	Soulard C.	476, 564
Pet I.	185	Sprainaitis A.	158
Petermann R.	496	Šrámek P.	398
Pflimlin A.	492	Staglianò S.	291
Picard F.	200	Steinshamn H.	162
Ponzetta M. P.	386	Stilmant D.	279, 327, 351, 445, 560
Popovici I. C.	528	Stofer S.	496
Porqueddu C.	43	Stroia M.C.	524
Postolache St.	528	Štýbnarová M.	70
Pötsch E.M.	138, 162, 463, 532	Stypinski P.	15, 520
Pozdíšek J.	70, 398, 536	Susan F.	402
Prokopowicz J.	556	Suter D.	417
Pycke B.	142	Suter M.	421
Raave H.	339	Svozilová M.	70, 398
Raison C.	492	Sýkorová Z.	223
Recous S.	227	Szemán L.	283
Reheul D.	1	Szewczyk W.	359

Tabaglio V.	347
Taube F.	82, 162, 227, 319, 463
Teixidor Albert N.	267
Thomson K.	488
Tomaskin J.	367
Tornambè G.	208
Van Bockstaele E.	86
Van Cleemput O.	259
van Dorland H.A.	162
van Eekeren N.	247
Van Passel S.	484
Vargetto D.	208
Vasilev E.	106
Vasileva V.	106
Vávrová L.	223
Velthof G.	227
Venerus S.	480
Venslauskas K.	587
Verlinden G.	142
Vertès F.	227, 335
Vestergaard J.	219
Viiralt R.	339
Vintu V.	146, 528
Violleau S.	200
Wachendorf M.	162
Walter T.	271
Wasilewski Z.	552
Webb J.	315
Weibel P.	382
Weisbjerg M.R.	166
Wiking L.	212, 219
Wilasini M.	259
Wolicka M.	114
Wrage N.	303
Wustenberghs H.	307
Wyłupek T.	500
Zarzycki J.	390
Ziliotto U.	402, 548
Zimková M.	15, 90
Zuperka V.	587