



HAL
open science

EVASPA : EVapotranspiration Assessment from SPace

Albert Oliosio, Belen Gallego-Elvira, Malik Bahir, Gilles Boulet, Marie Weiss,
Maria Mira Sarrio, Sergio Reyes Castillo

► **To cite this version:**

Albert Oliosio, Belen Gallego-Elvira, Malik Bahir, Gilles Boulet, Marie Weiss, et al.. EVASPA : EVapotranspiration Assessment from SPace. Workshop modélisation de surface, Nov 2015, Toulouse, France. hal-02800057

HAL Id: hal-02800057

<https://hal.inrae.fr/hal-02800057>

Submitted on 5 Jun 2020

HAL is a multi-disciplinary open access archive for the deposit and dissemination of scientific research documents, whether they are published or not. The documents may come from teaching and research institutions in France or abroad, or from public or private research centers.

L'archive ouverte pluridisciplinaire **HAL**, est destinée au dépôt et à la diffusion de documents scientifiques de niveau recherche, publiés ou non, émanant des établissements d'enseignement et de recherche français ou étrangers, des laboratoires publics ou privés.

EVASPA

EVapotranspiration Assessment from SPACe

**Albert Olioso, Belen Gallego-Elvira, Malik Bahir,
Gilles Boulet, Marie Weiss, Maria Mira, Sergio Castillo-Reyes**



ET (mm/day) 8 July 2008

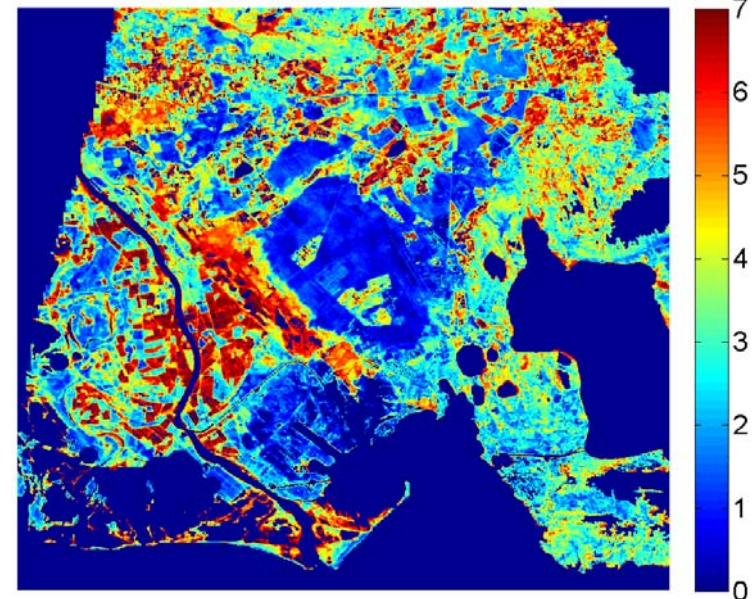

Objectives

Provide evapotranspiration **ET** maps at relevant spatial and time scales for agronomical and hydrological purposes

- > watershed hydrological balance
- > water stress and drought monitoring
- > crop water requirements and irrigation management

Account of the improvements in algorithm for mapping land surface variables (LAI, albedo, vegetation fraction cover) and evapotranspiration since the 90's

by combining Earth Observation and thermal infrared remote sensing

NB: Operational Evapotranspiration products are only few and have strong limitations (validity, temporal and spatial resolution)



Main features of EVASPA

- 1) Combination of Evapotranspiration models (ensemble calculation):
estimation of uncertainties
- 2) Integrate data from various remote sensing sensors (Easily adaptable to new sensors)
- 3) Continuous daily ET maps (interpolation methods)
- 4) Graphical User Interface (GUI) (MATLAB)

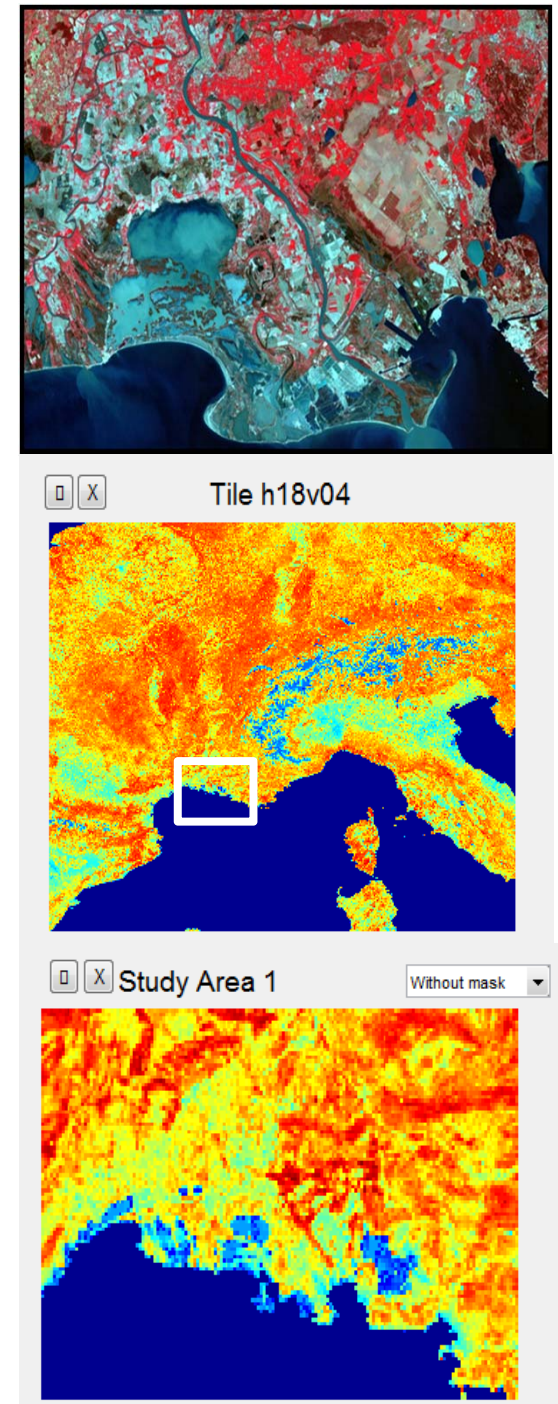

EVASPA.v1 – v2 (first operational versions)

- 1) MODIS data (TERRA and AQUA)
Continuous daily ET maps at kilometric spatial resolution
- 2) Landsat 5 and 7 High resolution ET maps (~hectometric) when images of the study area are available ;
- 3) extension to any VISIR-IRT sensors
- 4) Solar radiation from satellite products
- 5) Mapping algorithms based on
 - S-SEBI (Roerink 2000)
 - Triangle approach (Jiang and Islam 1999)
- 6) Several hypotheses in the calculations of albedo, emissivity, ground heat flux, net radiation, evaporative fraction, time interpolation

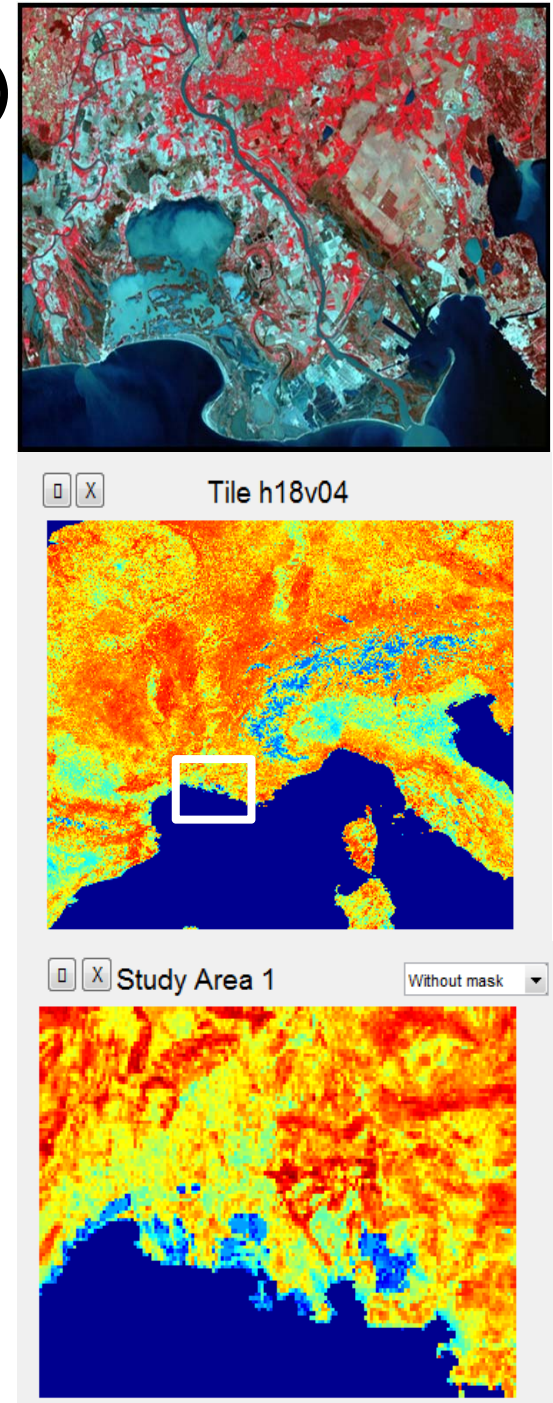

EVASPA algorithm for mapping ET from MODIS data

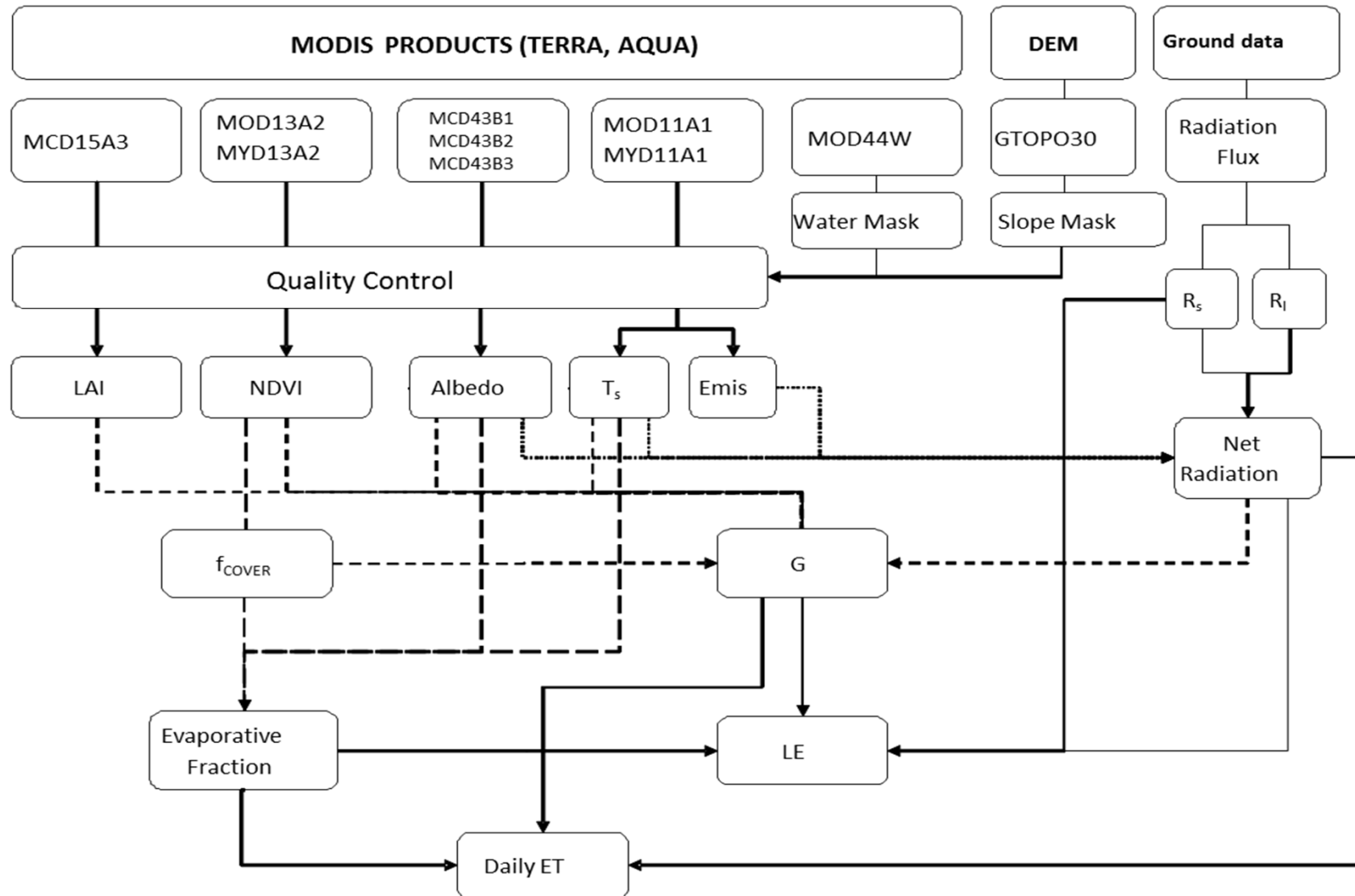

EVASPA algorithm for mapping ET from MODIS data

Sensor dependant part

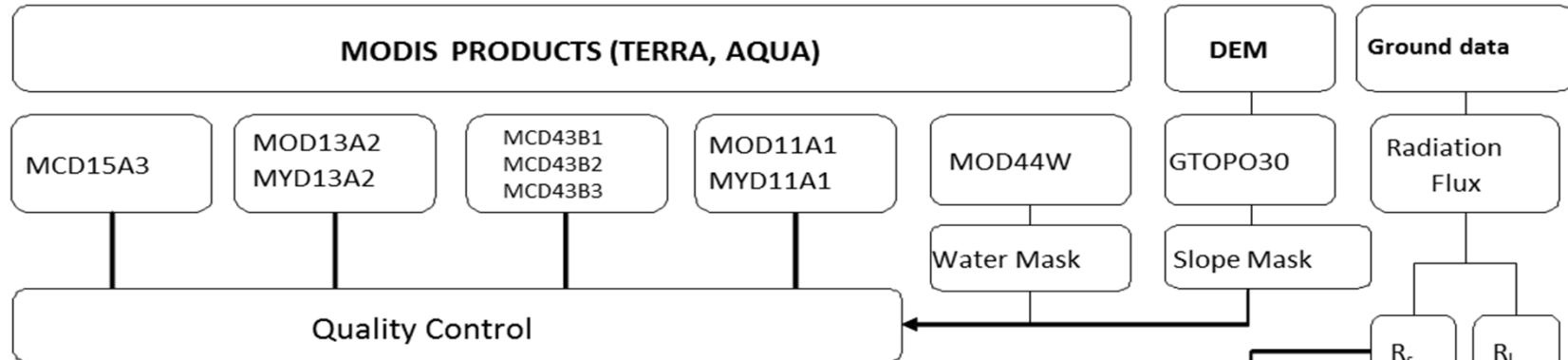

Generic part (ET algorithms)

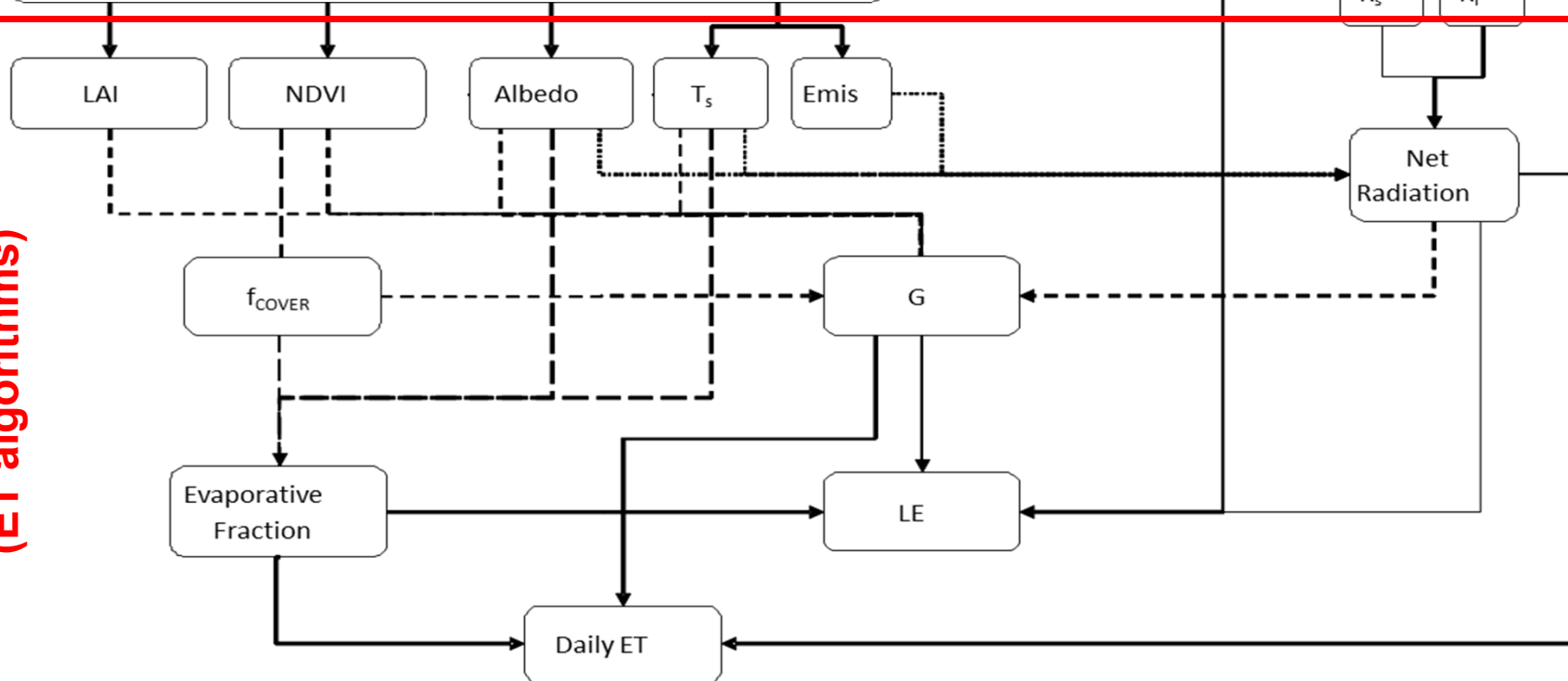

EVASPA algorithm for mapping ET from MODIS data

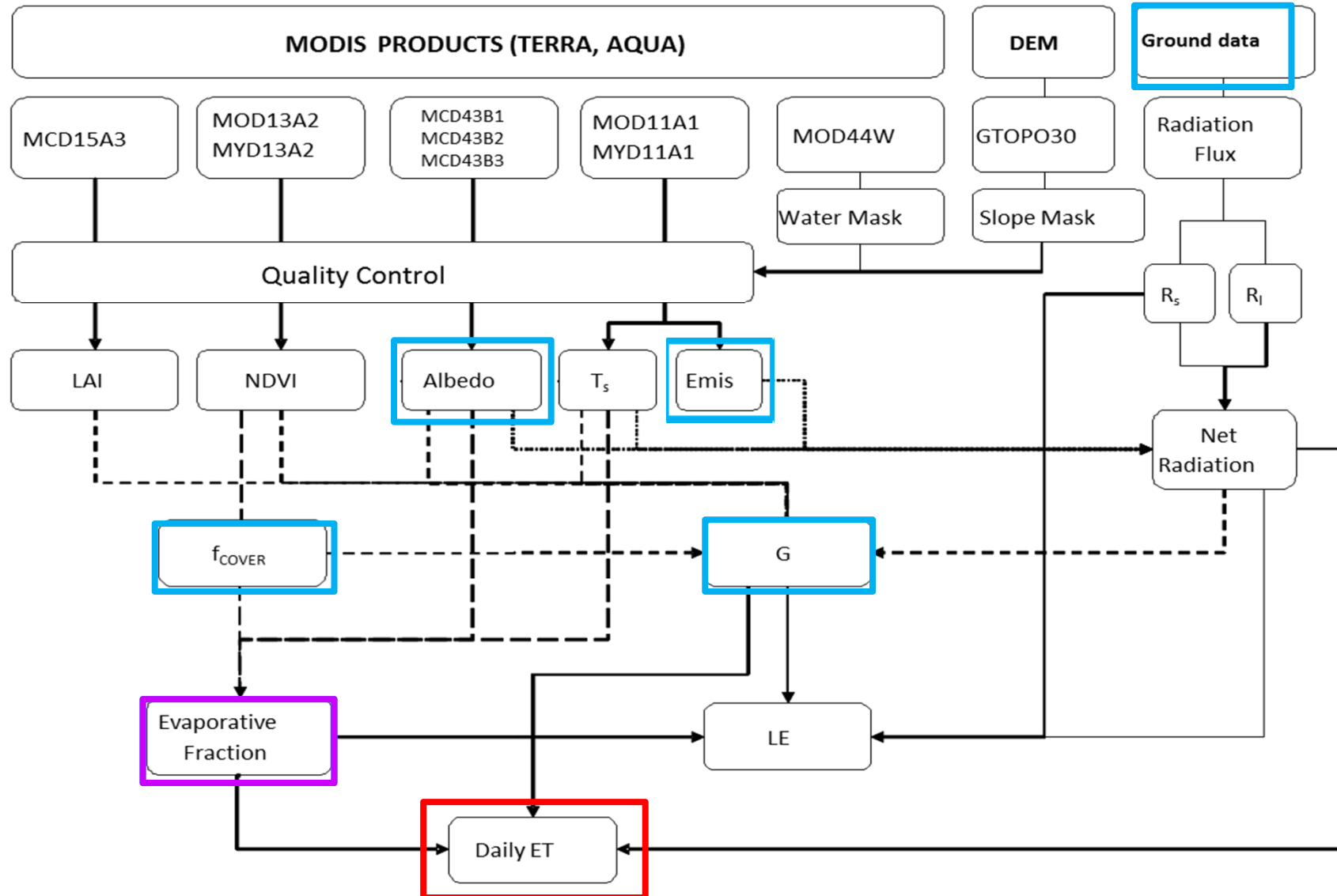

Example : continuous daily evapotranspiration from MODIS

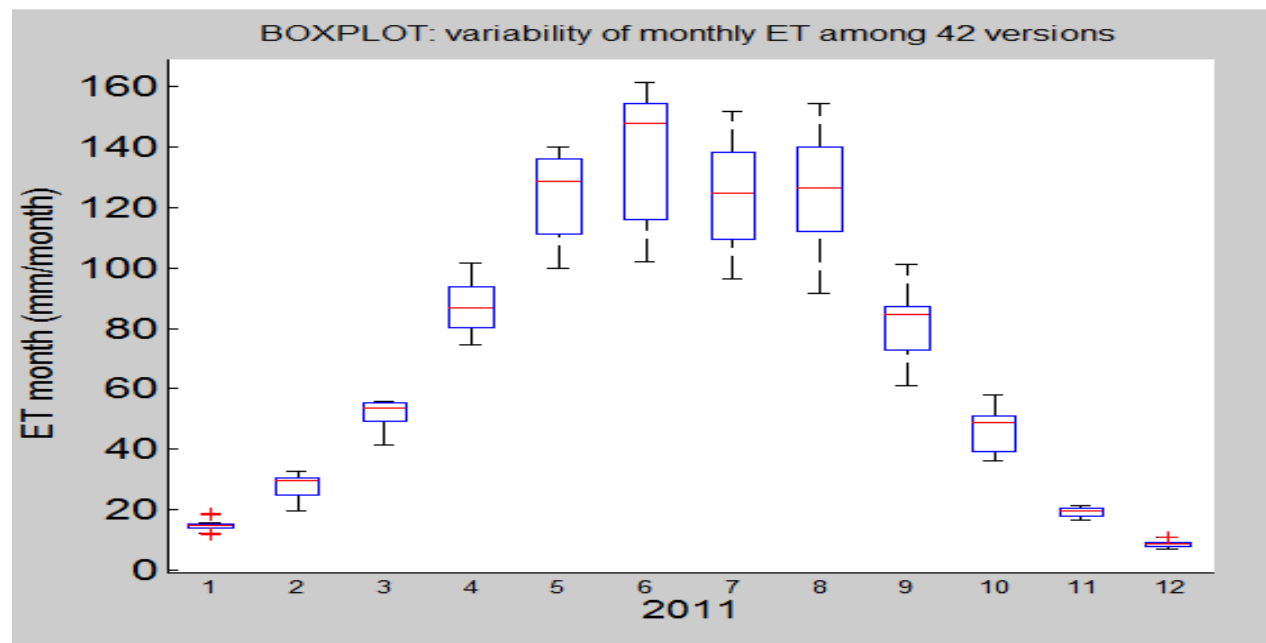
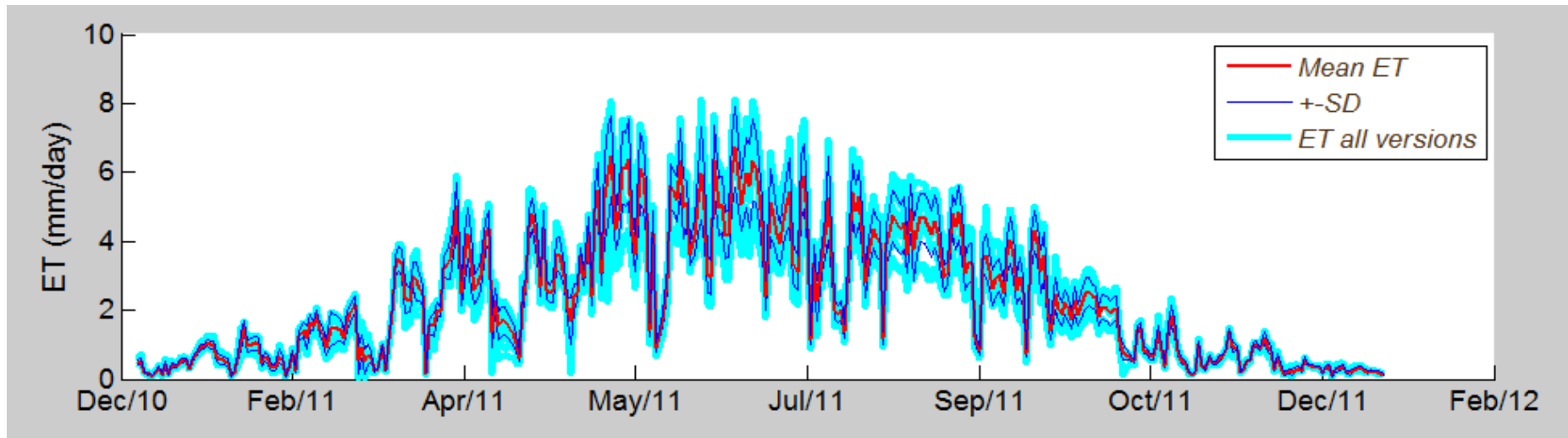

Uncertainties in latent heat flux (LE)

$$\delta(LE) = LE(\alpha_{best\ model}) - LE(\alpha_{worst\ model})$$

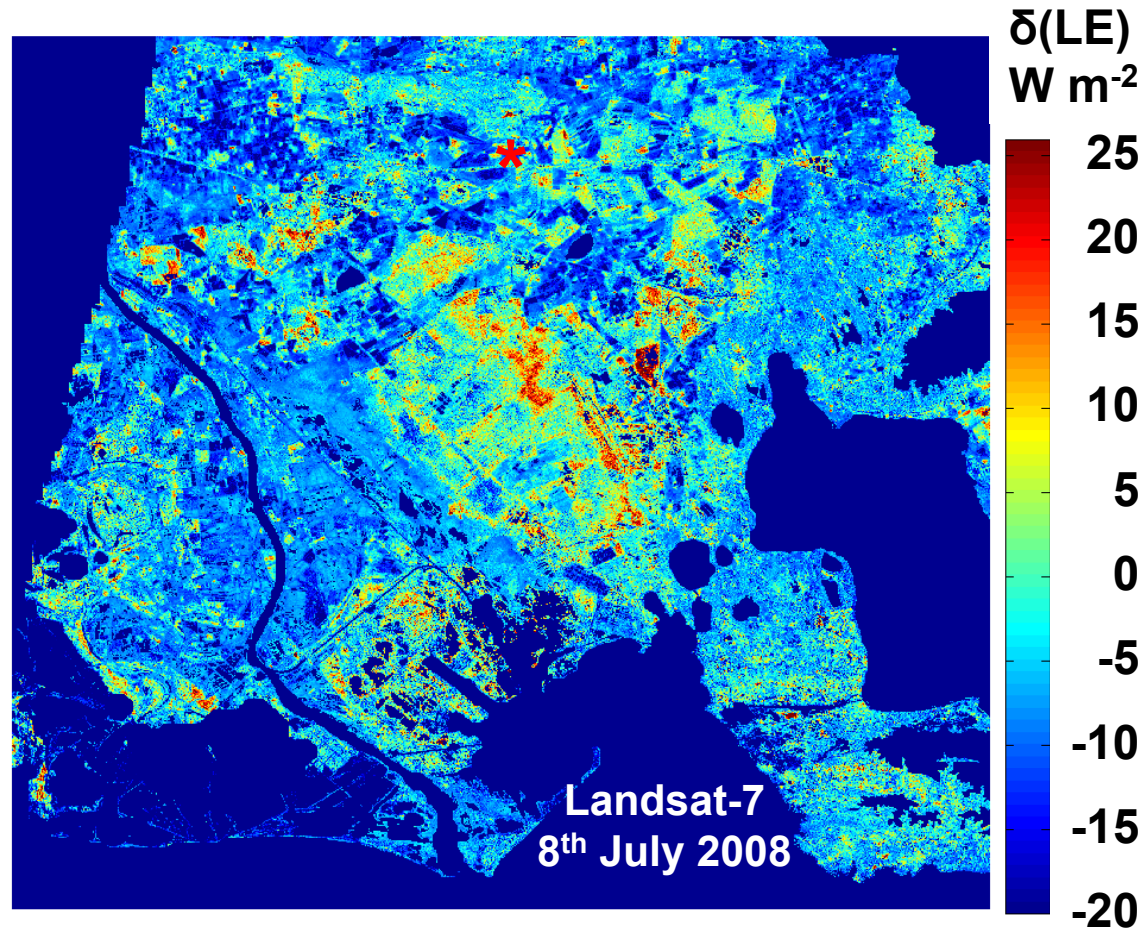

Instantaneous latent heat flux (LE) estimates at high spatial resolution using EVASPA tool (S-SEBI algorithm, LANDSAT 7)

a. GLOBAL uncertainty in net radiation
 δRn (Wm^{-2})

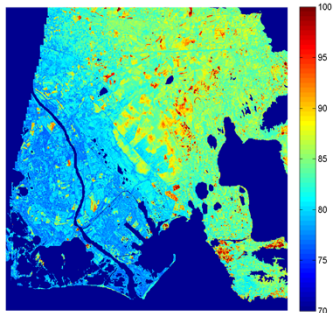

b. GLOBAL uncertainty for the first term of Eq. 1
(SOLAR contribution)
 $\delta[Rg^+ (1 - \alpha)]$ (Wm^{-2})

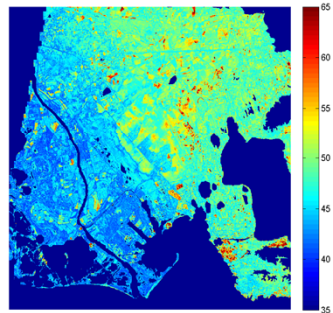

c. GLOBAL uncertainty for the second term of Eq. 1
(THERMAL contribution)
 $\delta[\epsilon (R\alpha^+ - \sigma T_s^4)]$ (Wm^{-2})

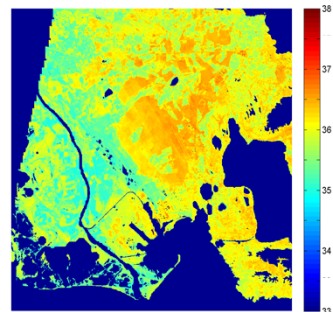

SOLAR contribution

d. $\delta Rn(\alpha)$ (Wm^{-2})

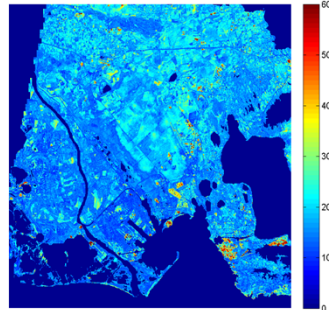

e. $\delta Rn(\alpha_s)$ (Wm^{-2})

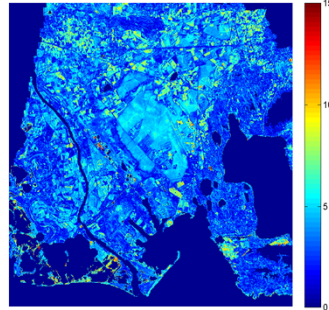

f. $\delta Rn(\rho_s)$ (Wm^{-2})

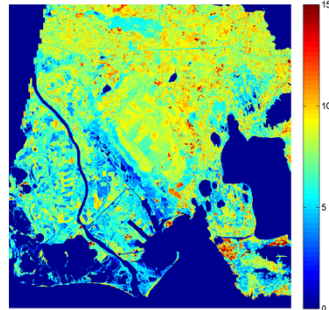

THERMAL contribution

g. $\delta Rn(Tb_{10.4-12.5\mu m})$ (Wm^{-2})

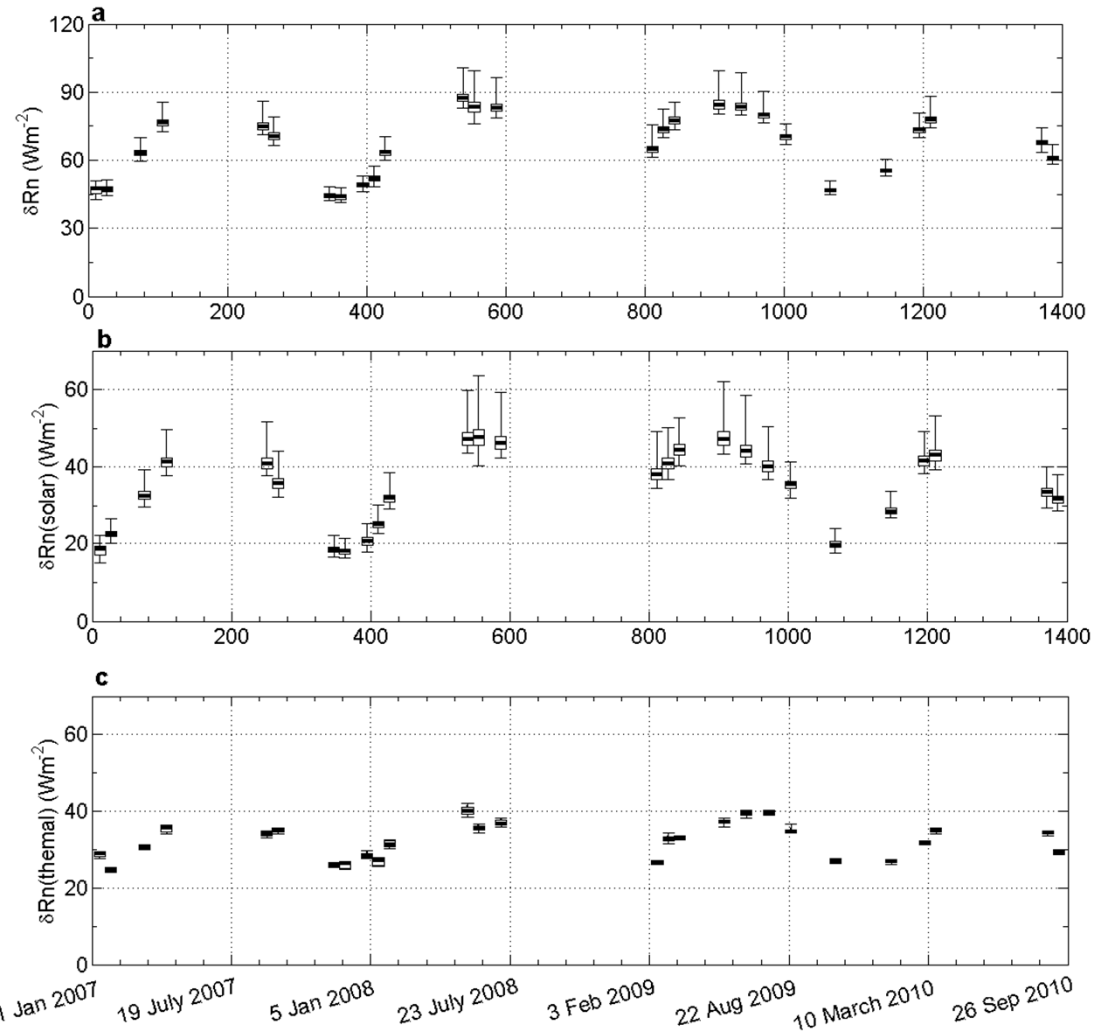
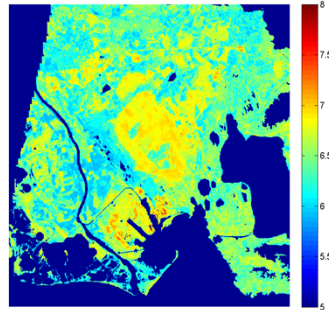

Uncertainty assessment of surface net radiation derived from Landsat

Mira, Olioso, Gallego et al., en révision (mineure) dans RSE

Comparaison des estimation d'évapotranspiration par rapport aux mesures de terrain sur les coussouls de Crau

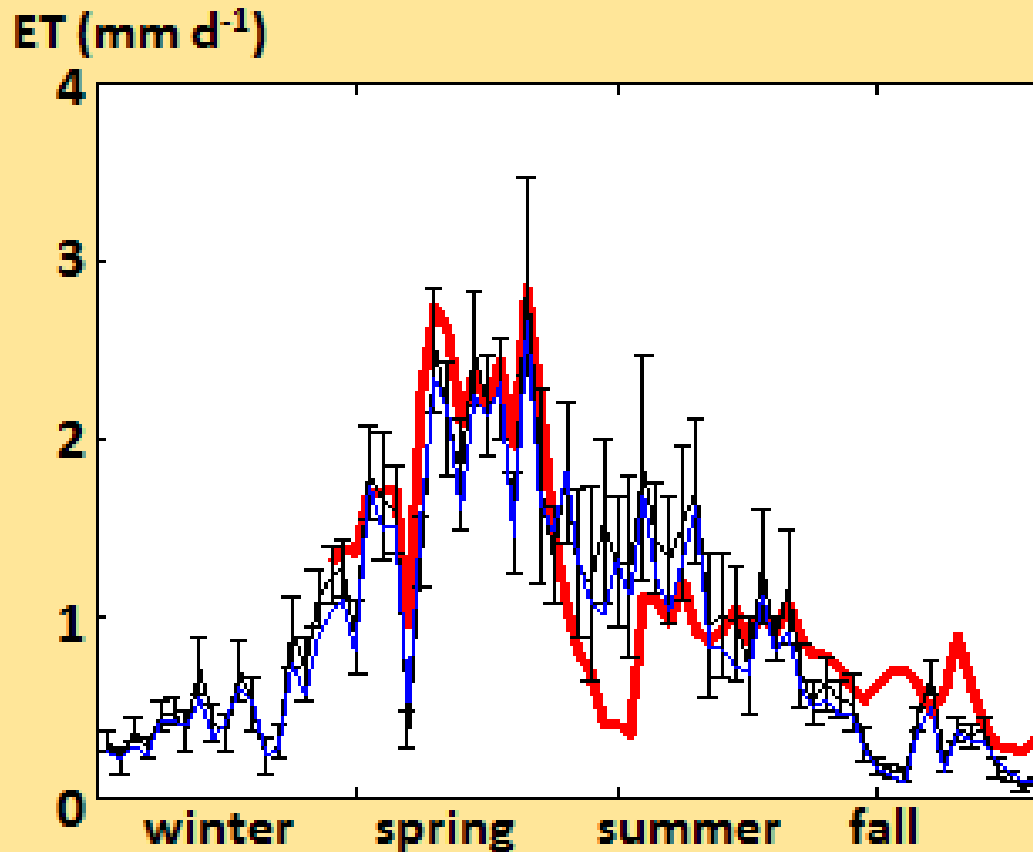

- Ground measurements over dry grassland site (4)
- EVASPA average and standard deviation (17 models, 2 satellites)
- Best model

Application: bilan hydrique de l'aquifère de Crau (550 km²)

Monthly evapotranspiration (mm)

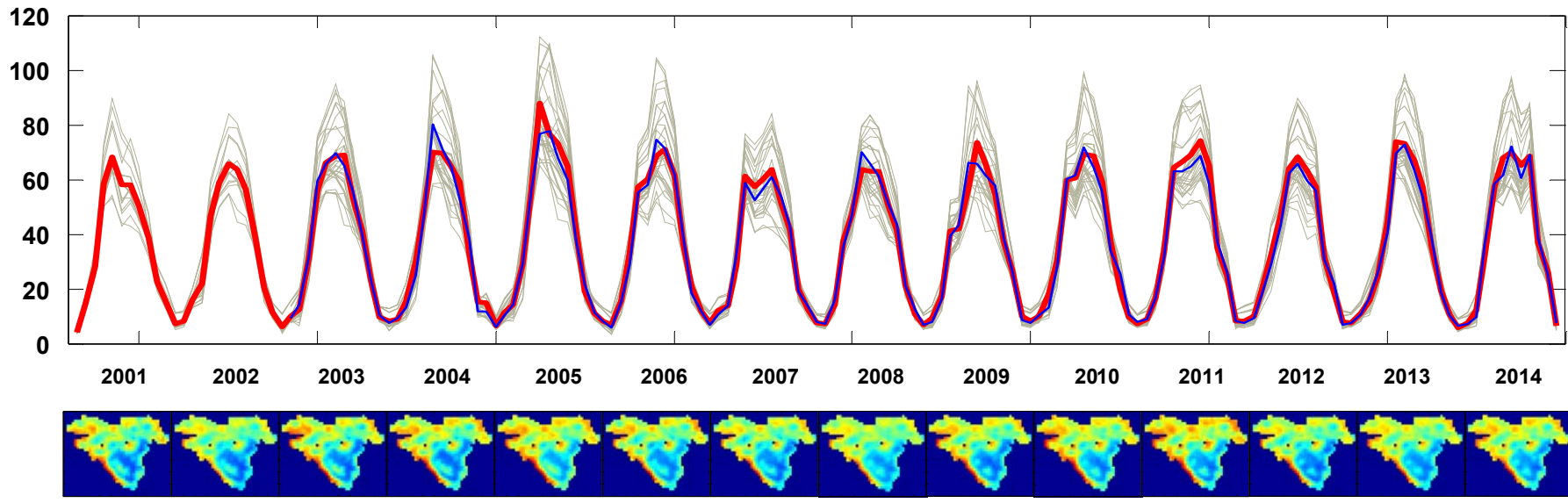

- █ MODIS TERRA model average
- █ MODIS AQUA model average
- █ All models

Water balance of the Crau aquifer area

EVASPA		Oliosio et al. (2013)	
Rain (Salon)	299 hm ³	Rain (SAFRAN)	294 hm ³
Rain (Istres)	260 hm ³	ET (surface models)	321 hm ³
ET	239 hm ³ [224 -261 hm ³]	Irrigation	297 hm ³
		Drainage	277 hm ³

Annual evapotranspiration (mm y⁻¹)

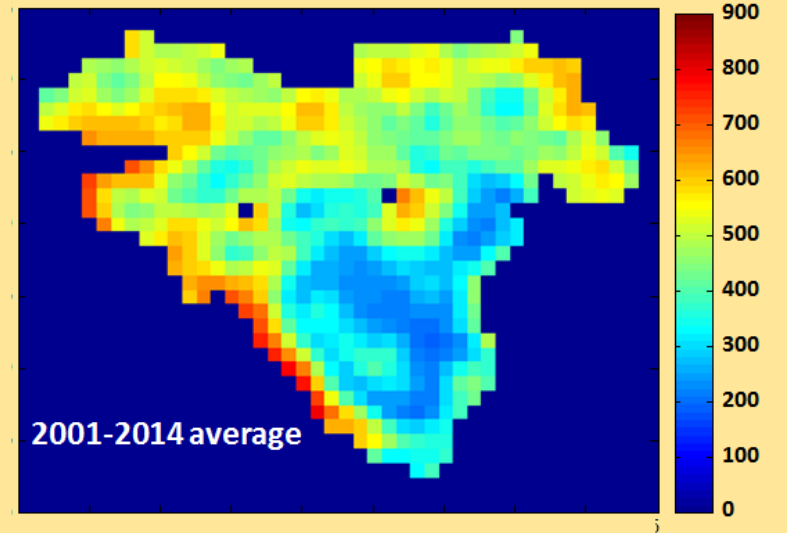

Ex: INRA: EVAPOTRANSPIRATION

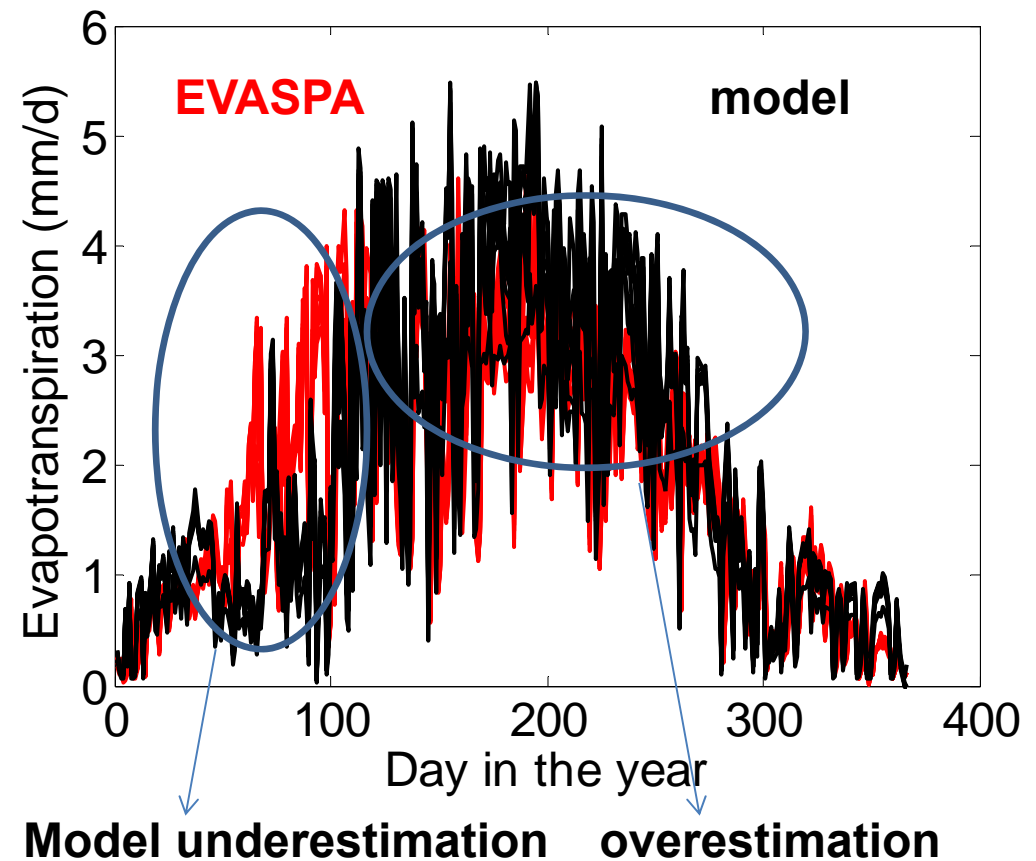
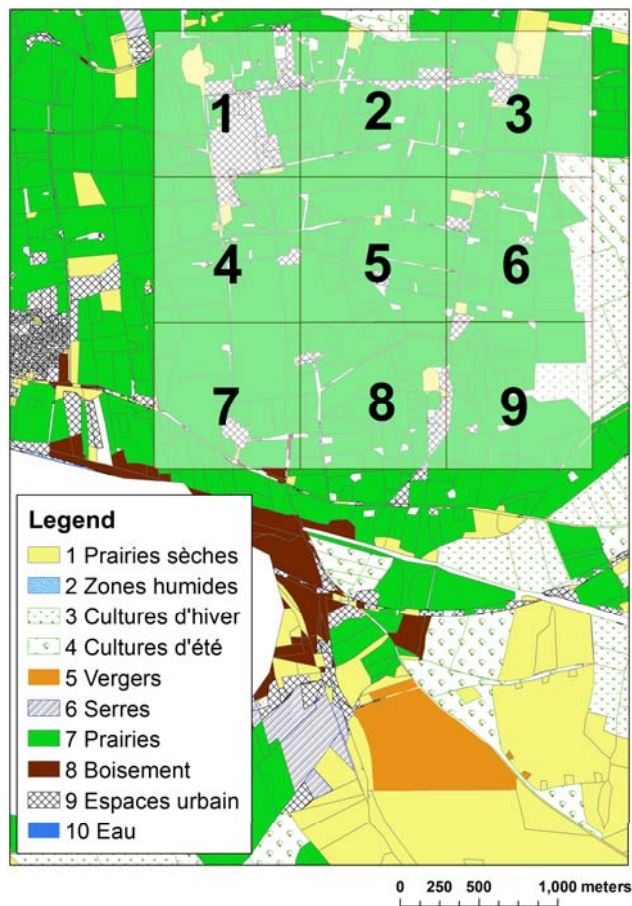

Tour du Valat – Camargue – France

MODIS data against ground station
and water table fluctuations

saltmarsh scrubs

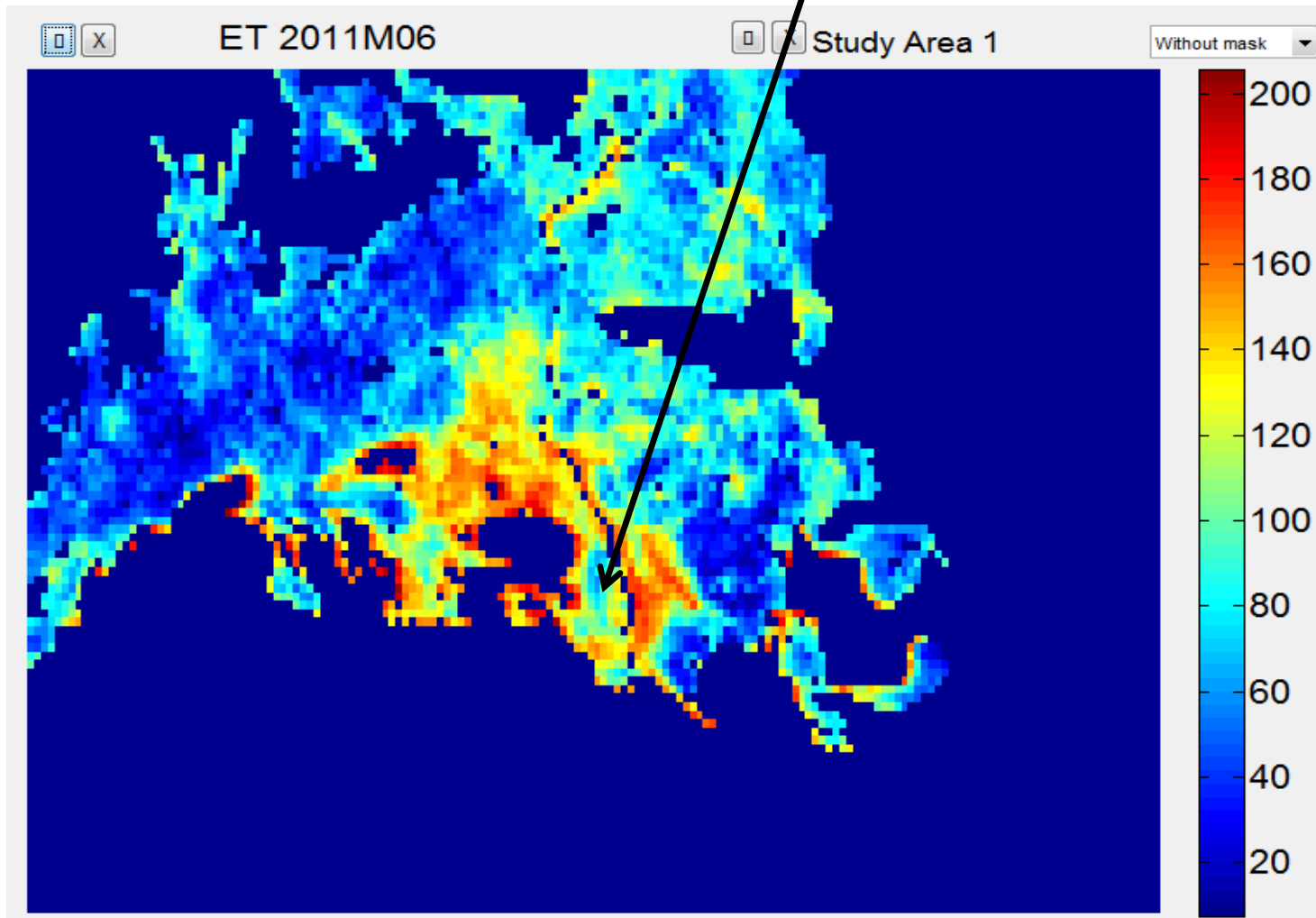

Tour du Valat – Camargue – France

MODIS data

saltmarsh scrubs

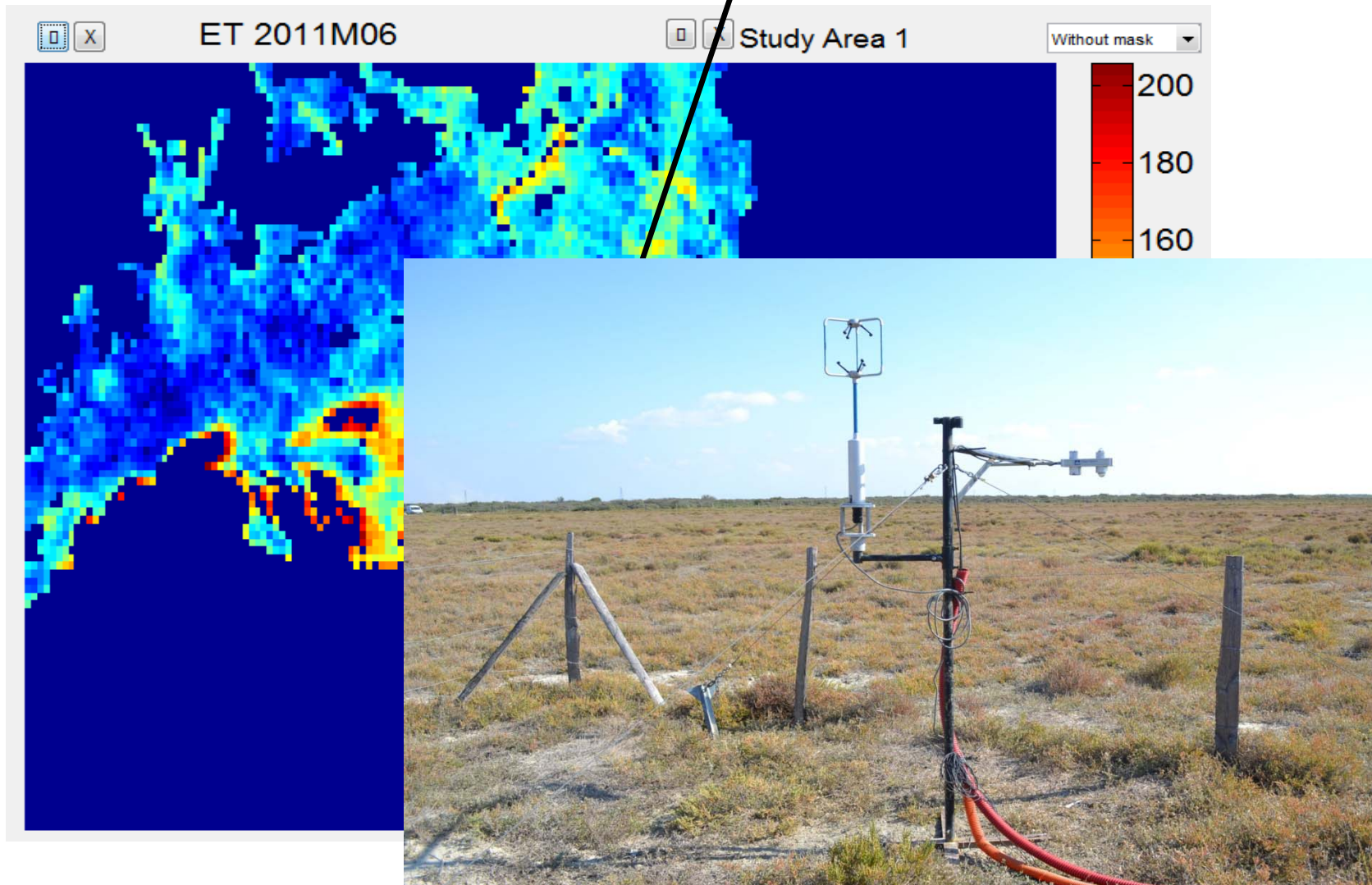

EVASPA ET estimations vs. ground stations

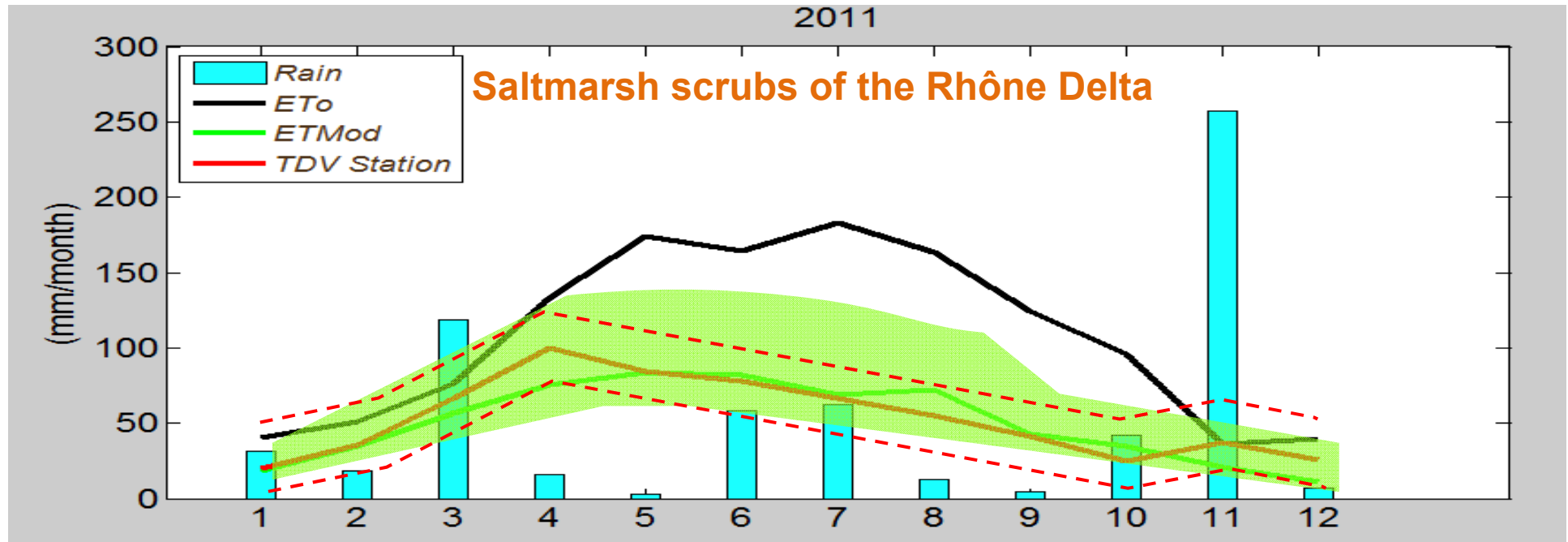

Identification of best performance methods for different surfaces and water stress conditions

EVASPA TOOL

Evapotranspiration in the saltmarsh scrubs and its relationship with water table

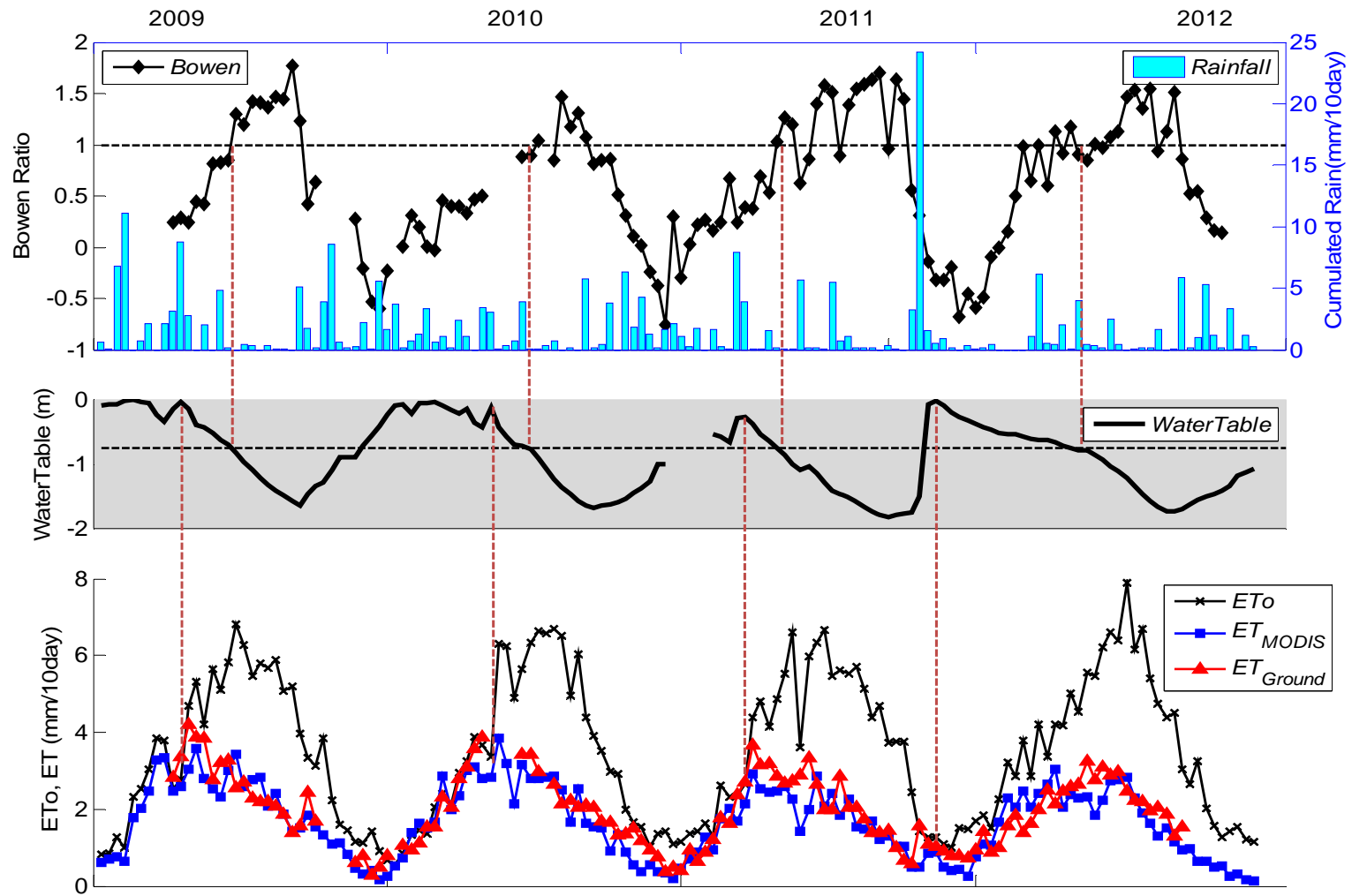

Evolution of evapotranspiration, rain and water table

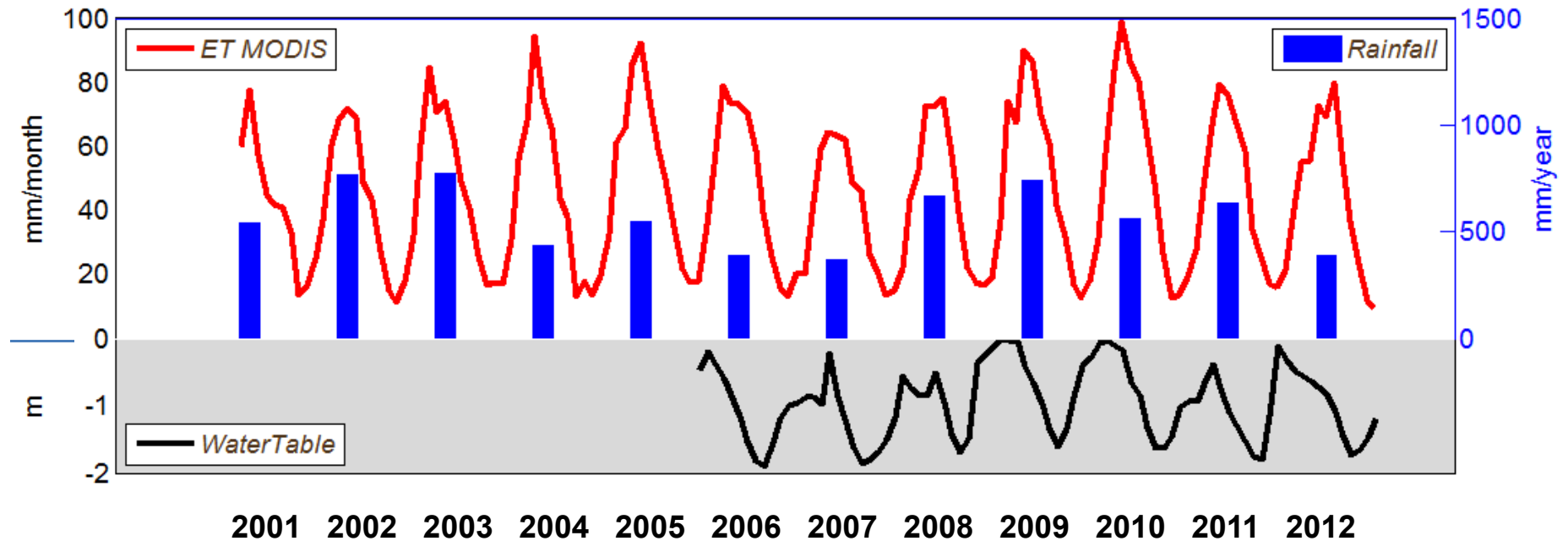

Ground measurements
period -> « training »

Application of EVASPA from MODIS data
-> extrapolation of evapotranspiration measurements

Final remarks

EVASPA integrates

- several methods to derive ET
- data from several remote sensing sensors

Work in progress

- performance assessment in several laboratories and over various types of landscapes
- identify the most suitable and reliable methods for different surfaces and water stress conditions
- uncertainty assessment
- evaluation of land surface models (LSM, SVAT, Crop Models) against evapotranspiration chronicles from EVASPA
- inclusion of new sensors and new models

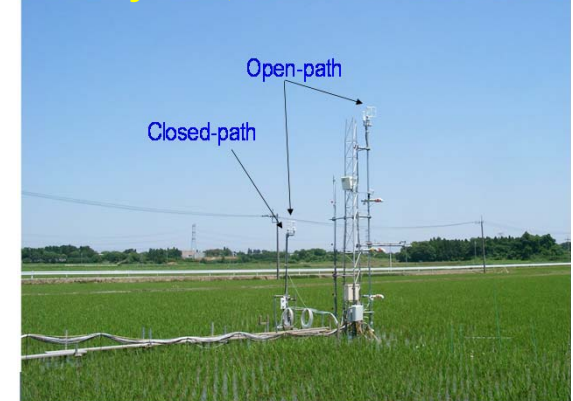

EVASPA V3.0

Projet TOSCA AO 2015

Coord. A.Olioso, coll. CESBIO (coord. G. Boulet), NASA-JPL (P. Guillevic)

Objectifs:

- Implémenter les nouveaux algorithmes dans EVASPA2.0 = **EVASPA 3.0**
(modèles SEBS, TSEB et SEB-4S)
 - Intégrer les données des nouveaux capteurs ou produits:
VIIRS, LANDSAT8, MASTER et MODIS v6
 - Produire une **estimation d'ensemble** de l'ETR élaborée à l'aide de la combinaison des algorithmes
 - Elaborer une méthode de **réduction de l'ensemble** basée sur une présélection des algorithmes à l'aide de données observées (calibration) ou par analogie (paysages)
 - Amélioration des procédures d'interpolation / extrapolation temporelle pour passer de l'échelle « instantanée » à l'échelle journalière et pour combler l'absence de données.
- + proposition d'un premier algorithme dans le CES Evapotranspiration du pôle THEIA

THANK YOU FOR YOUR ATTENTION

Supports

⇒ CNES (TOSCA calls) in the frame of the thermal infrared satellite mission project **MISTIGRI**

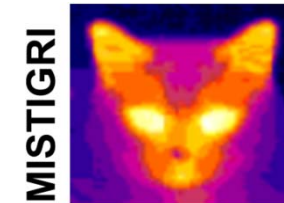

⇒ Application to water balance of irrigated Mediterranean catchments in the frame of the SIRRIMED FP7 project and SICMED



⇒ Fundacion Ramon Areces (Spanish program for post-doc fellowships)



MISTRALS

Mediterranean I
at Regional A



Triangle method:
Evaporative Fraction (EF)

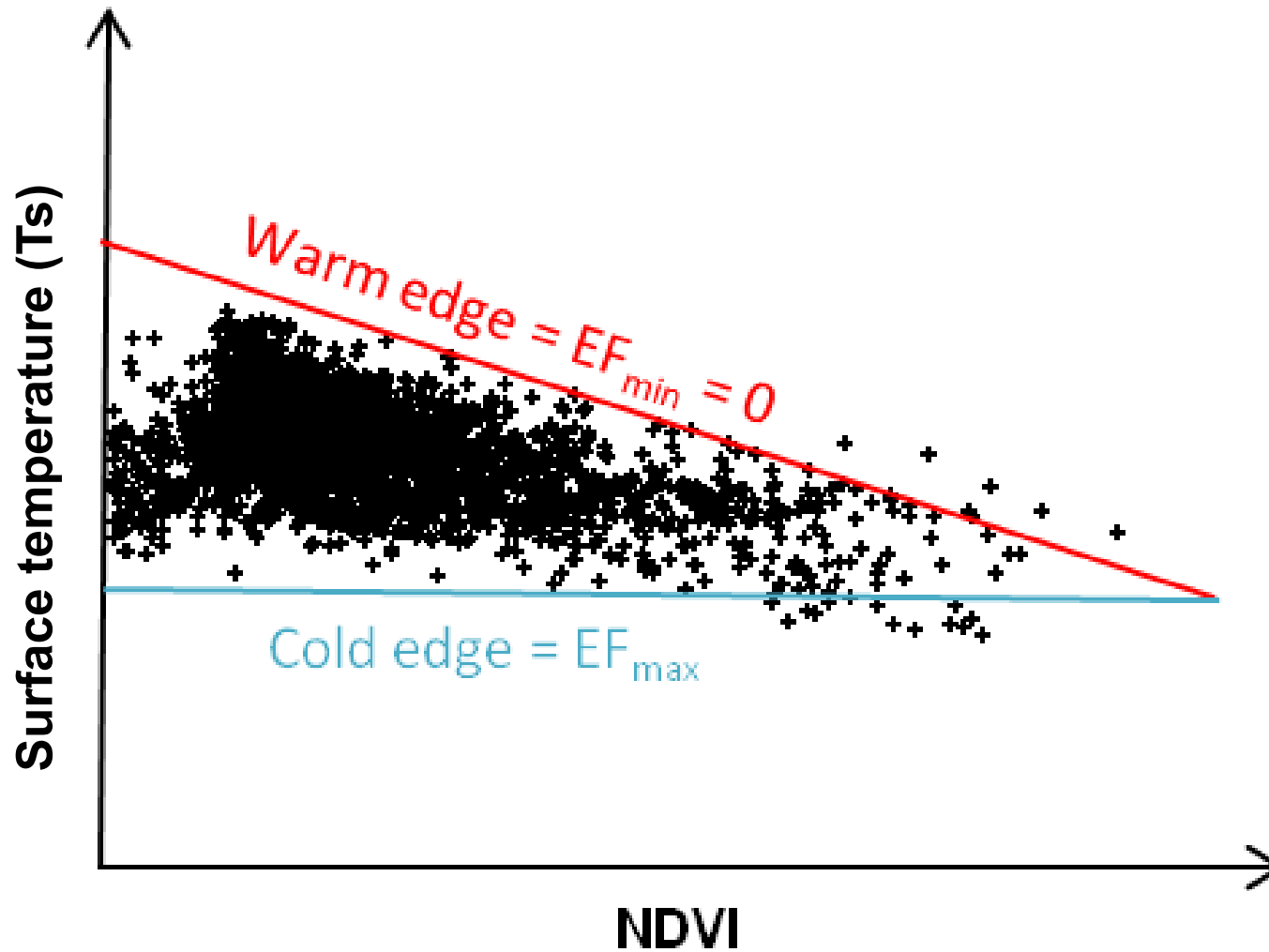

Triangle method: Evaporative Fraction (EF)

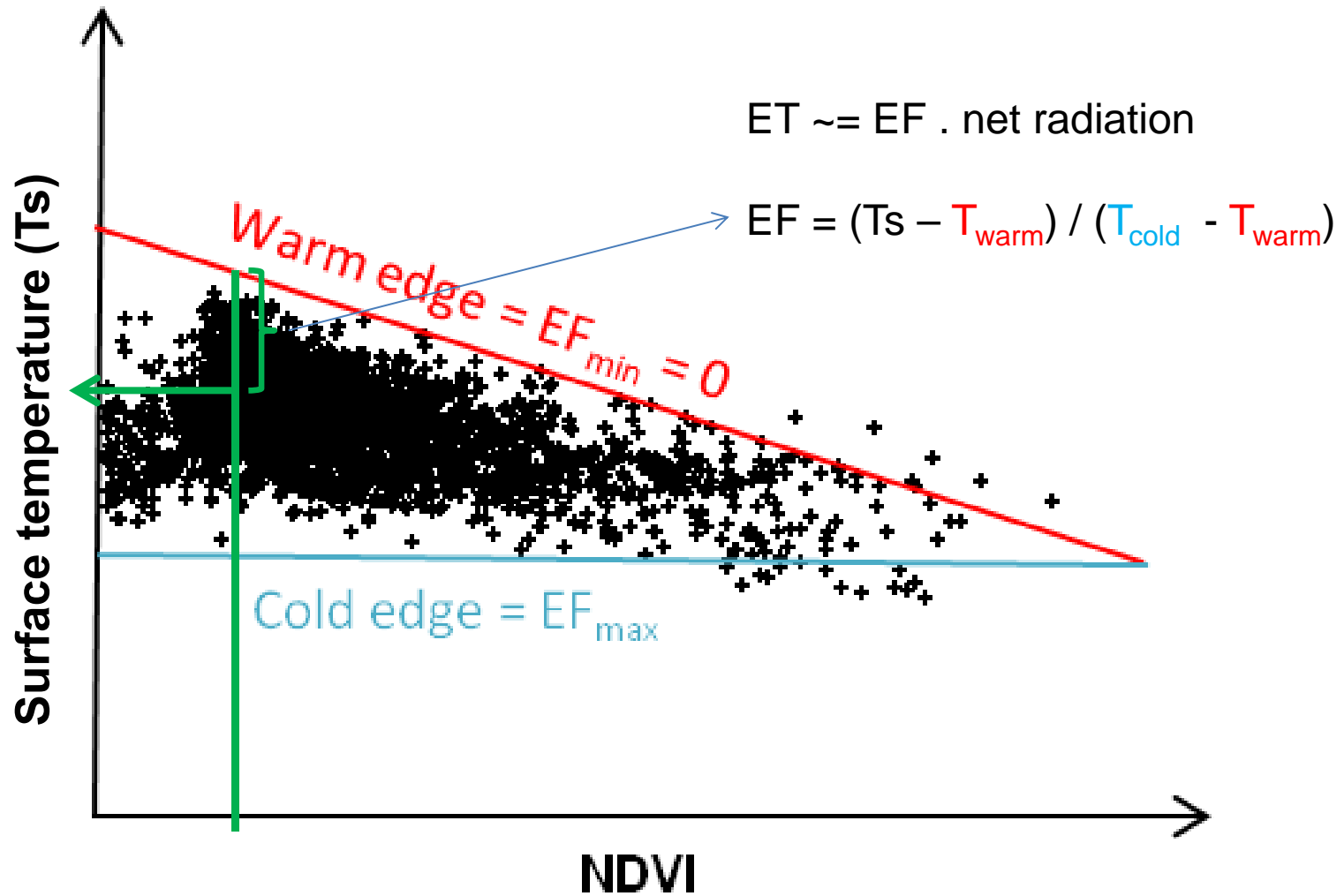

Triangle method: Evaporative Fraction (EF)

EF1

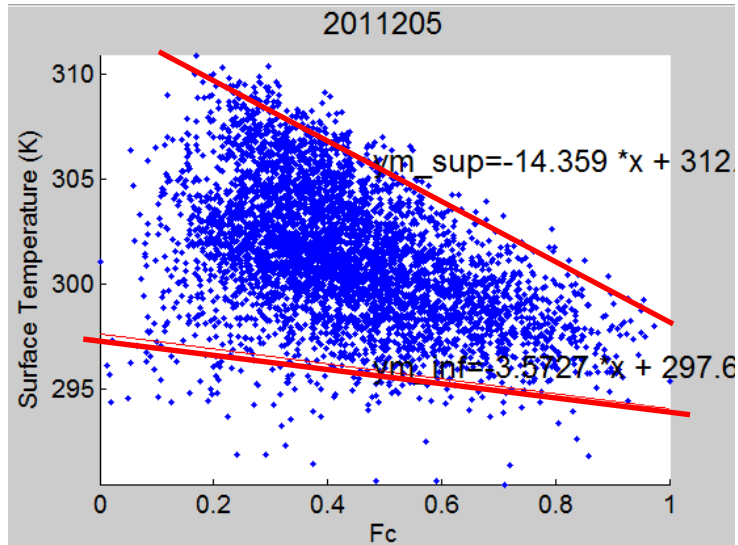

EF2

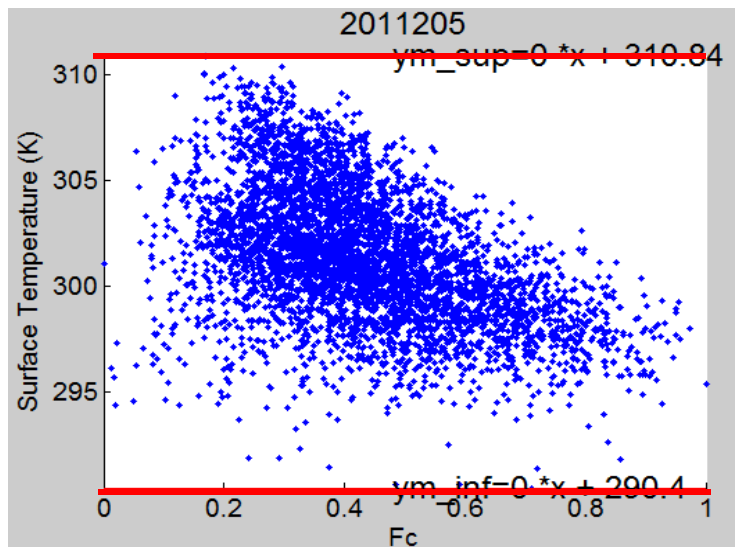
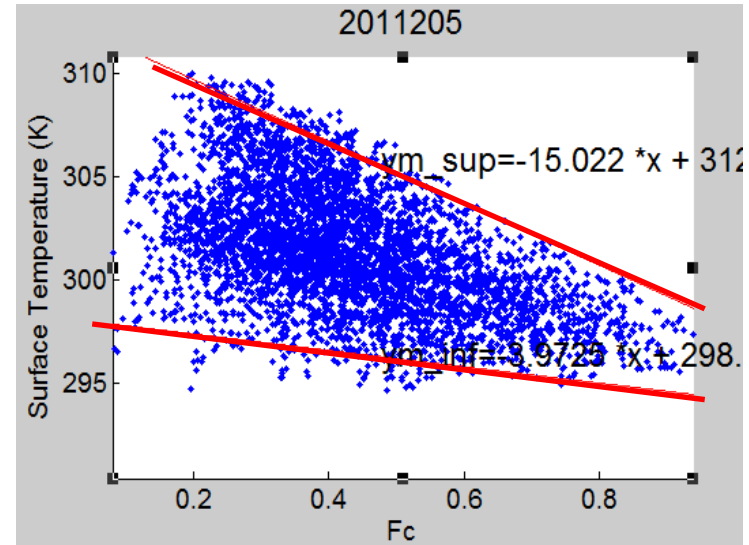

EF3

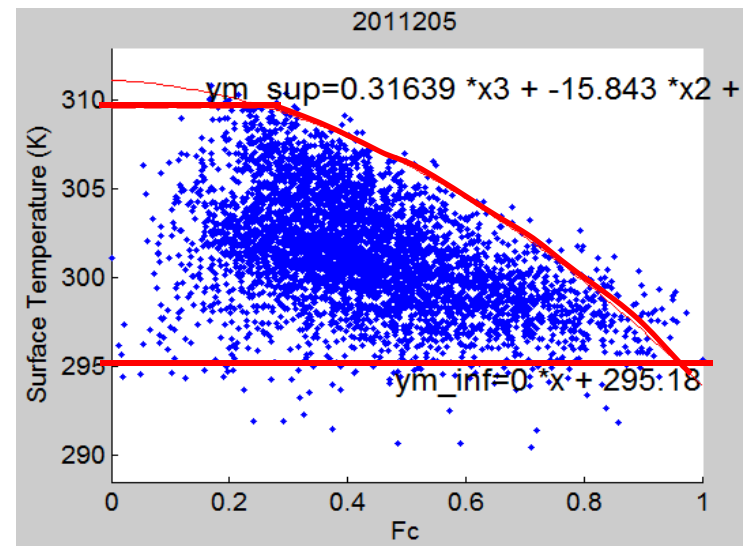

EF4