



**HAL**  
open science

## Stochastic metapopulation modeling of influenza dynamics: framework and conditions for replacement and coexistence of several co-circulating subtypes

Elisabeta Vergu, Sébastien Ballesteros, Caroline C. Bidot, Bernard Cazelles,  
Anton Camacho

### ► To cite this version:

Elisabeta Vergu, Sébastien Ballesteros, Caroline C. Bidot, Bernard Cazelles, Anton Camacho. Stochastic metapopulation modeling of influenza dynamics: framework and conditions for replacement and coexistence of several co-circulating subtypes. Journées de l'ANR Manège, Jan 2012, Marseille, France. 53 diapos. hal-02806242

**HAL Id: hal-02806242**

**<https://hal.inrae.fr/hal-02806242>**

Submitted on 6 Jun 2020

**HAL** is a multi-disciplinary open access archive for the deposit and dissemination of scientific research documents, whether they are published or not. The documents may come from teaching and research institutions in France or abroad, or from public or private research centers.

L'archive ouverte pluridisciplinaire **HAL**, est destinée au dépôt et à la diffusion de documents scientifiques de niveau recherche, publiés ou non, émanant des établissements d'enseignement et de recherche français ou étrangers, des laboratoires publics ou privés.

# Stochastic metapopulation modeling of influenza dynamics: framework and conditions for replacement and coexistence of several co-circulating subtypes

Elisabeta Vergu<sup>1</sup>, Sébastien Ballesteros<sup>2</sup>, Anton Camacho<sup>3,4</sup>, Caroline Bidot<sup>1</sup>,  
Bernard Cazelles<sup>3,4</sup>

<sup>1</sup>INRA - MIA UR341, Jouy-en-Josas, France; <sup>2</sup>Ecology and Evolutionary Biology Department, Princeton University, USA;  
<sup>3</sup>Ecole Normale Supérieure - UMR 7625, Paris, France; <sup>4</sup>UPMC, Paris, France

Séminaire ANR MANEGE, Marseille 01 février 2012

# Outline

- 1 My lab: research topics
- 2 Influenza characteristics and motivation for this work
- 3 Simple models for multi-strain dynamics
- 4 Influenza A gradual and epochal evolution: insights from simple models
- 5 Framework and conditions of coexistence and replacement in the case of a pandemic

# Outline

- 1 My lab: research topics
- 2 Influenza characteristics and motivation for this work
- 3 Simple models for multi-strain dynamics
- 4 Influenza A gradual and epochal evolution: insights from simple models
- 5 Framework and conditions of coexistence and replacement in the case of a pandemic

## A few words on my lab “Applied mathematics and informatics” (MIA)

20 permanent researches and engineers, 10 PhD students, 3 Post-docs

Part of the “Applied mathematics and informatics department” of the National Institute for Agricultural Research (INRA)

Three teams:

- image analysis and spatio-temporal modeling of biological systems (AnIMod team)
  - ▶ spatial statistics, 3D reconstruction, reduction of order of EDO systems
  - applications in cell biology and physiology
- analysis of large sets of data and complex models in biology (MegaDim team)
  - ▶ high-dimensional statistics (multiple testing, variable selection, inference in graphical models)
  - ▶ numerical experiments (meta-modelling, sensitivity and uncertainty analyses, high dimensional simulations)
  - applications in molecular genetics, epidemiology, environment
- modelling and analysis of dynamical phenomena met in agro-ecology, epidemiology (DynEnVie team)

- Modelling, analysis and prediction of complex dynamical phenomena (individuals and metapopulations in interactions, spatial or network structure, uncertainty and stochasticity, heterogeneous and missing data)
  - ▶ **dynamical systems**: analysis and reduction of order, numerical exploration
  - ▶ **stochastic processes**: branching processes, diffusion processes
  - ▶ **bayesian statistics, statistical inference for diffusion processes**
- Understanding, evaluation and prediction of impacts and risks
  - ▶ **epidemiology**
  - ▶ **agronomy and environment at the scale of small agricultural land**
  - ▶ **food safety and nutrition**

# Outline

- 1 My lab: research topics
- 2 Influenza characteristics and motivation for this work
- 3 Simple models for multi-strain dynamics
- 4 Influenza A gradual and epochal evolution: insights from simple models
- 5 Framework and conditions of coexistence and replacement in the case of a pandemic

# Influenza dynamics: seasonal epidemics and occasional pandemics

Regular phase and variable amplitude

2009 pandemic: earlier start of the outbreak

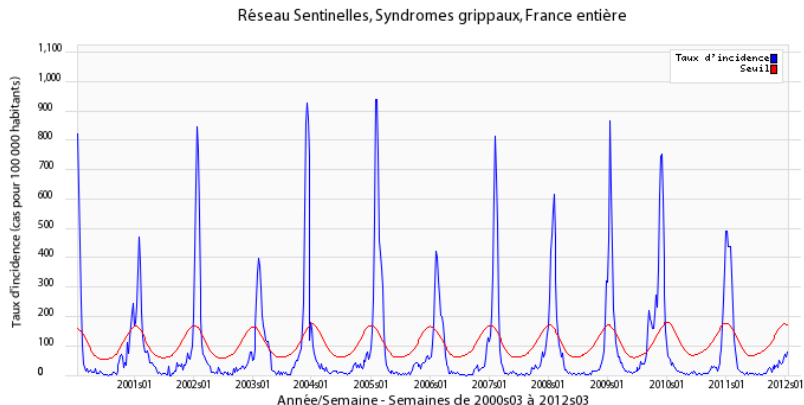



## Diversity of influenza virus

- 3 phylogenetically and antigenically distinct viral **types** A, B and C
- 2 main antigens: 16 haemagglutinin (HA) and 9 neuramidase (NA): **subtypes HxNy** (not all of 144 combinations have been found)
- ssRNA-viruses, genome (13kb) composed of 8 segments (reassortment possible): **strains**

Pandemic strains obtained through reassortment

# Influenza: seasonal outbreaks and genetic diversity at the population level

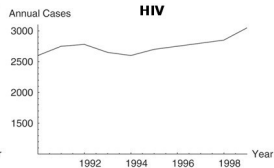
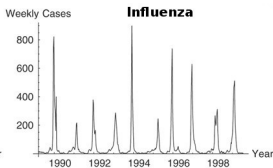
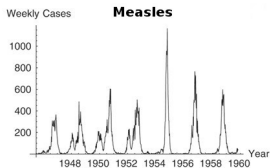

Measles virus population phylogeny

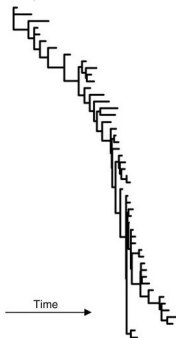

Human influenza A virus population phylogeny

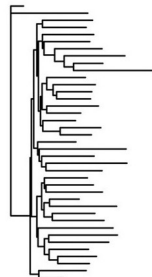

HIV population phylogeny

# Correspondance between genetic and antigenic evolution of influenza main antigen HA

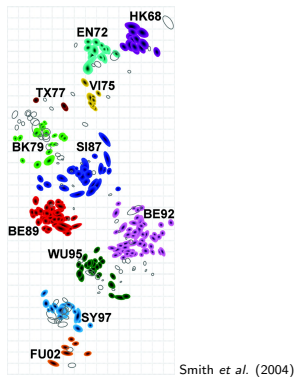
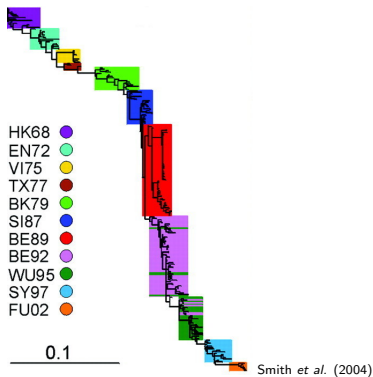

## Combination of phylogenetic and antigenic data

- Ladder-like branching structure
- Punctuated evolution of influenza main antigen

# Correspondance between genetic and antigenic evolution of influenza main antigen HA

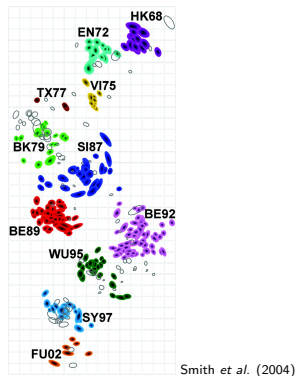
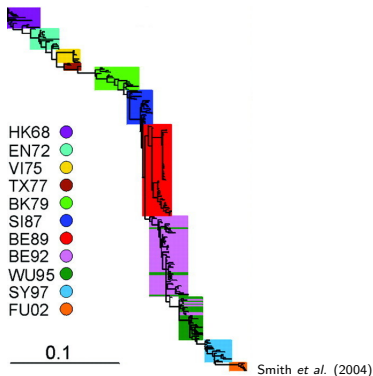

## Combination of phylogenetic and antigenic data

- Ladder-like branching structure
- Punctuated evolution of influenza main antigen

## Pandemics (1)

During past influenza pandemics the new subtype replaced previously circulating subtypes, except in 1977

- in 1957 the A/H2N2 subtype replaced the pandemic A/H1N1 subtype circulating since 1918
- in 1968 the A/H3N2 subtype replaced the A/H2N2 subtype
- in 1977 the A/H1N1 subtype reocured and has cocirculated with the A/H3N2 subtype until the last year

## Pandemics (2)

2009 pandemic: the great majority of worldwide subtyped influenza viruses was pandemic A/H1N1

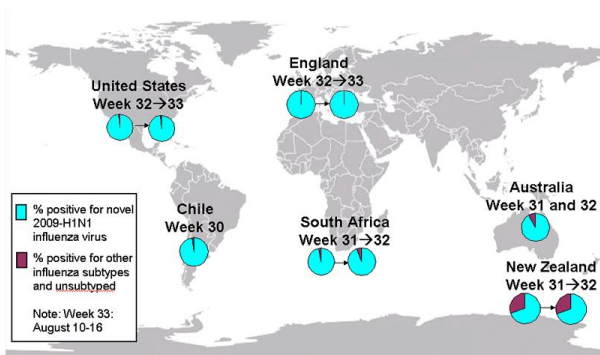

## Pandemics (2)

During 2010 influenza season the previous circulating A/H3N2 subtypes came back

# Context and motivation (1)

Figure courtesy of S. Ballesteros

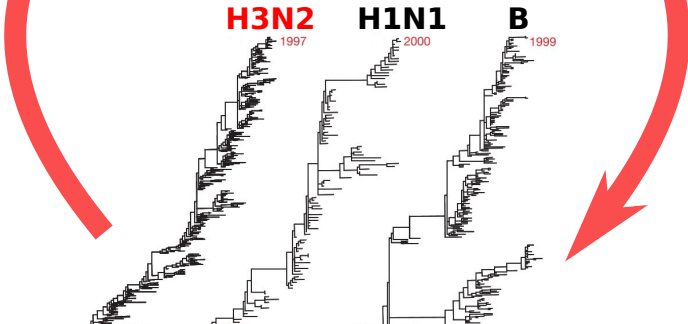
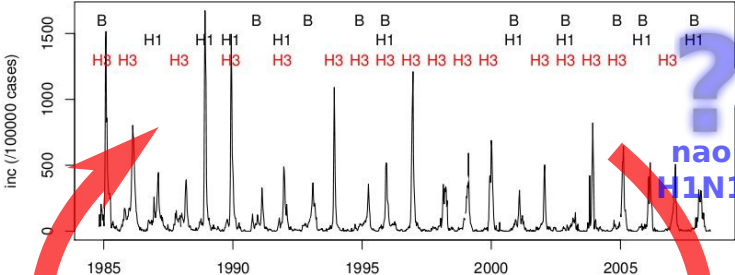



## Context and motivation (2)

Three models have been proposed to explain the distinctive phylodynamic pattern observed in human A/H3N2 viruses:

- viral strains are characterized by a short-lived strain-transcending immunity (Ferguson *et al.*, Nature 2003)
- HA evolves in a punctuated manner among antigenic types that are linked by a network of neutrally evolving sites (Koelle *et al.*, Science 2006)
- the virus continually reuses a limited number of antigenic combinations (Recker *et al.*, PNAS 2007)

Hypothesis explaining influenza phylodynamics supported by complex simulations

→ difficult to assess the consequences of modelling assumptions

→ difficult to understand the conditions supporting co-circulation and replacement dynamics following the occurrence of a new pandemic strain

# Outline

- 1 My lab: research topics
- 2 Influenza characteristics and motivation for this work
- 3 Simple models for multi-strain dynamics**
- 4 Influenza A gradual and epochal evolution: insights from simple models
- 5 Framework and conditions of coexistence and replacement in the case of a pandemic

# Types of equation-based multi-strain *SIR* models

## *SIR* model

- partitioning the host population into  $S$  (susceptible),  $I$  (infectious),  $R$  (recovered) compartments
- abundance in  $S$ ,  $I$  and  $R$  classes tracked through time (e.g. ODEs)

## Classification of the multi-strain *SIR* models

- with respect to cross-immunity
  - ▶ history-based (*HB*): hosts grouped based on all strains with which they have ever been infected (Andreasen *et al.*, JMB 1997)
  - ▶ status-based (*SB*): hosts grouped based on all strains against which they are immune (Gog and Swinton, MB 2002)
- with respect to the mechanism of protective immunity
  - ▶ reduced susceptibility (*RS*)
  - ▶ reduced infectivity (*RI*)

## Notation and construction: *HBRS* model (Andreasen *et al.*, JMB 1997)

$\Omega = \{1, 2, 3, \dots, n\}$  the set of all possible strains

$R_J$  the set of individuals currently uninfected and previously infected by the strains in the set  $J \subset \mathcal{P}(\Omega) \rightarrow 2^n$  classes

$R_\emptyset$  the set of individuals who had not encountered any infections

$I_J^i$  the set of individuals currently infected by strain  $i$  and previously recovered from infectious with strains in  $J \rightarrow n2^{n-1}$  classes

$J \setminus j = J \setminus \{j\}$

$\beta_i$  transmission rate of strain  $i$

$\sigma_J^i$  reduction in susceptibility when infected with strain  $i$  when immune history  $J$  ( $\sigma_\emptyset^i = 1$ ,

$\sigma_J^i \leq \sigma_L^i$  for  $L \subseteq J$ )

$\nu_i$  recovery rate from infection with strain  $i$

$$\dot{R}_J = \sum_{j \in J} \nu_j I_{J \setminus j}^j - \sum_{i \notin J} \sigma_J^i R_J \beta_i \sum_{J \subseteq \Omega \setminus i} I_J^i$$

$$\dot{I}_J^i = \sigma_J^i R_J \beta_i \sum_{J \subseteq \Omega \setminus i} I_J^i - \nu_i I_J^i$$

## Notation and construction: *SBRIS* model (Gog and Swinton, MB 2002)

$R_J$  the set of individuals currently uninfected and immune to the strains in the set

$J \subset \mathcal{P}(\Omega) \longrightarrow 2^n$  classes

$R_\emptyset$  the set of individuals immune to none strain

$I^i$  the set of individuals currently infected by strain  $i \longrightarrow n$  classes

$C(K, J, i)$  the proportion of hosts that recover to a state  $J$  having started in  $K$  and been infected by strain  $i$  ( $i \notin K$ ,  $i \in J$ ,  $K \subset J$ ,  $\sum_J C(K, J, i) = 1$ )

$$\dot{R}_J = \sum_{i, K} C(K, J, i) \beta_i I^i R_K - \sum_{i \notin J} \beta_i I^i R_J$$

$$\dot{I}^i = \beta_i I^i \sum_{J: i \notin J} R_J - \nu_i I^i$$

# Outline

- 1 My lab: research topics
- 2 Influenza characteristics and motivation for this work
- 3 Simple models for multi-strain dynamics
- 4 Influenza A gradual and epochal evolution: insights from simple models**
- 5 Framework and conditions of coexistence and replacement in the case of a pandemic

# Influenza A gradual and epochal evolution: insights from simple models

Ballesteros S, Vergu E, Cazelles B. PLoS One 2009, 4(10):e7426

Comparison of the consequences of *SB* and *HB* formulations with *RS* and *RI* assumptions on the transient dynamics of antigenic clusters

Study of the invasion of a new antigenic cluster within a population where a resident antigenic cluster is at the endemic equilibrium

## Illustration on a two-strain model

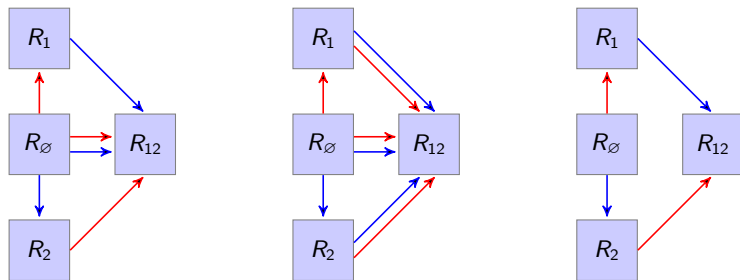

*SBRS* (left), *SBRI* (middle), *HB* (right) models  
Infection with strain 1 (red arrows) and with strain 2 (blue arrows).



## Invasion dynamics for SB and HB models

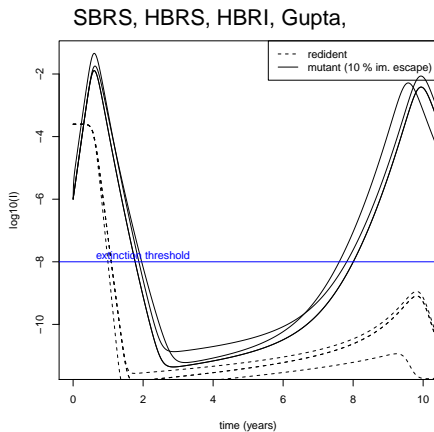

Cluster replacement only for the *SBRI* model

## Invasion dynamics for SB and HB models

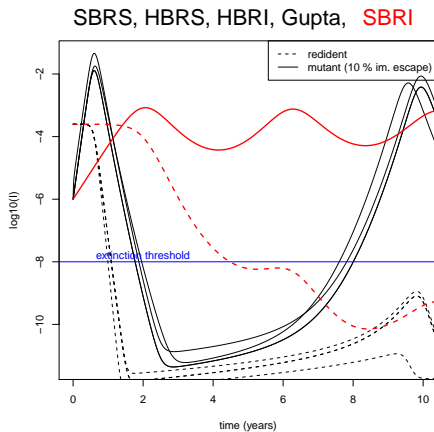

Cluster replacement only for the **SBRI** model

## Invasion condition for the mutant cluster

Easily obtained after algebraic manipulation from  $\dot{I}^2 > 0$

*SBRI* model:  $1 + \sigma(\beta/\nu - 1)/((1 - \sigma)(\beta/\nu - 1) + 1)$

all other models:  $1 + \sigma(\beta/\nu - 1)$

$\beta$ : transmission rate (assumed equal for both strains);  $\nu$ : recovery rate;  $\sigma \in [0, 1]$ :  
immune escape rate

$$\dot{R}_\emptyset = -\beta_1 R_\emptyset I^1 - \beta_2 R_\emptyset I^2$$

$$\dot{R}_1 = (1 - \sigma)\beta_1 R_\emptyset I^1 - \beta_1 R_1 I^1 + (1 - \sigma)\beta_1 R_1 I^1 - \beta_2 R_1 I^2$$

$$\dot{R}_2 = (1 - \sigma)\beta_2 R_\emptyset I^2 - \beta_2 R_2 I^2 + (1 - \sigma)\beta_2 R_2 I^2 - \beta_1 R_2 I^1$$

$$\dot{R}_{12} = \sigma\beta_1 R_\emptyset I^1 + \sigma\beta_2 R_\emptyset I^2 + \sigma\beta_1 R_1 I^1 + \sigma\beta_2 R_2 I^2 + \beta_2 R_1 I^2 + \beta_1 R_2 I^1$$

$$\dot{I}^1 = \beta_1 R_\emptyset I^1 + \beta_1 R_2 I^1 - \nu I^1$$

$$\dot{I}^2 = \beta_2 R_\emptyset I^2 + \beta_2 R_1 I^2 - \nu I^2$$

- Reformulating the model (new variables  $S_i$ )  $\longrightarrow$  order reduction:
  - ▶  $S_1 = R_\emptyset + R_2$  (hosts susceptible to strain 1)
  - ▶  $S_2 = R_\emptyset + R_1$  (hosts susceptible to strain 2)
- $2K$  variables instead of  $2^K$
- However, cross-immune boosting appears to be problematic

$$\dot{R}_\emptyset = -\beta_1 R_\emptyset I^1 - \beta_2 R_\emptyset I^2$$

$$\dot{R}_1 = (1 - \sigma)\beta_1 R_\emptyset I^1 - \beta_1 R_1 I^1 + (1 - \sigma)\beta_1 R_1 I^1 - \beta_2 R_1 I^2$$

$$\dot{R}_2 = (1 - \sigma)\beta_2 R_\emptyset I^2 - \beta_2 R_2 I^2 + (1 - \sigma)\beta_2 R_2 I^2 - \beta_1 R_2 I^1$$

$$\dot{R}_{12} = \sigma\beta_1 R_\emptyset I^1 + \sigma\beta_2 R_\emptyset I^2 + \sigma\beta_1 R_1 I^1 + \sigma\beta_2 R_2 I^2 + \beta_2 R_1 I^2 + \beta_1 R_2 I^1$$

$$\dot{I}^1 = \beta_1 R_\emptyset I^1 + \beta_1 R_2 I^1 - \nu I^1$$

$$\dot{I}^2 = \beta_2 R_\emptyset I^2 + \beta_2 R_1 I^2 - \nu I^2$$

- Reformulating the model (new variables  $S_i$ )  $\longrightarrow$  order reduction:
  - ▶  $S_1 = R_\emptyset + R_2$  (hosts susceptible to strain 1)
  - ▶  $S_2 = R_\emptyset + R_1$  (hosts susceptible to strain 2)
- $2K$  variables instead of  $2^K$
- However, cross-immune boosting appears to be problematic

# Outline

- 1 My lab: research topics
- 2 Influenza characteristics and motivation for this work
- 3 Simple models for multi-strain dynamics
- 4 Influenza A gradual and epochal evolution: insights from simple models
- 5 Framework and conditions of coexistence and replacement in the case of a pandemic

# Framework and conditions of coexistence and replacement in the case of a pandemic

Vergu, Ballesteros *et al.*, work in progress

Another formulation than the problematic *SBRI* model  $\longrightarrow$  *HB* model

New assumptions are necessary

Aim: exploring the possible outcomes after the introduction of the new virus

- To provide a general framework capturing the dynamics of co-circulating subtypes
- To characterize replacement and coexistence conditions in terms of
  - ▶ basic reproductive number,  $R_0$ 
    - ★ illustrates the ability of a pathogen to invade a population
  - ▶ antigenic drift rate ( $\stackrel{\text{notation}}{=} g = 1/D$ )
    - ★ describes the continuous process of genetic and antigenic change among flu strains
    - ★ accounts for the virus ability to escape immune system
  - ▶ seasonal forcing
  - ▶ underlying biological mechanisms

## Model (1): main modelling assumptions, key processes of influenza dynamics

One subtype

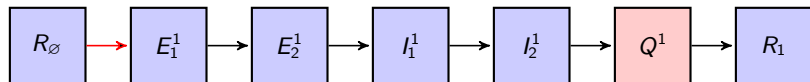

- inclusion of a latent state  $E$
- not realistic assumption of exponential distribution for latency and infectious durations  $\longrightarrow$  Erlang distribution
- temporary period of full cross protection ( $Q$ ) (Ferguson *et al.*, Nature 2003)
- gradual antigenic drift



## Model (1): main modelling assumptions, key processes of influenza dynamics

One subtype

antigenic drift

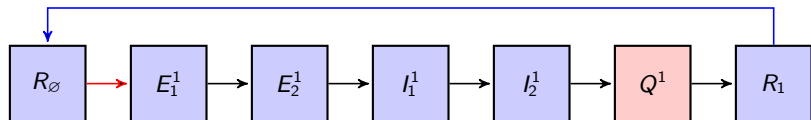

- inclusion of a latent state  $E$
- not realistic assumption of exponential distribution for latency and infectious durations  $\longrightarrow$  Erlang distribution
- temporary period of full cross protection ( $Q$ ) (Ferguson *et al.*, Nature 2003)
- gradual antigenic drift

# Model (1): main modelling assumptions, key processes of influenza dynamics

Invasion of the second subtype

antigenic drift

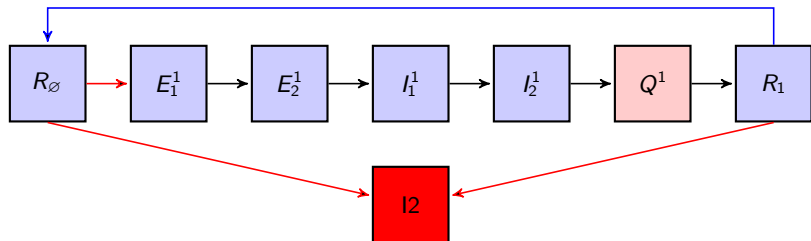

- inclusion of a latent state  $E$
- not realistic assumption of exponential distribution for latency and infectious durations  $\rightarrow$  Erlang distribution
- temporary period of full cross protection ( $Q$ ) (Ferguson *et al.*, Nature 2003)
- gradual antigenic drift

# Model (1): main modelling assumptions, key processes of influenza dynamics

Two subtypes

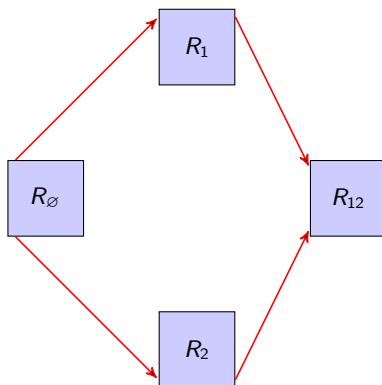

- infection

# Model (1): main modelling assumptions, key processes of influenza dynamics

Two subtypes

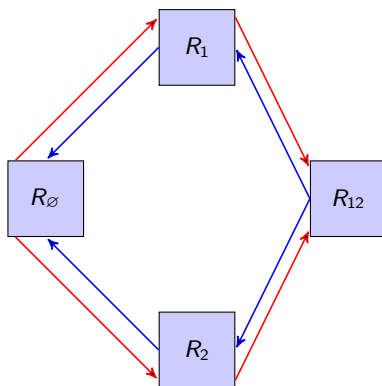

- antigenic drift

## Model (1): main modelling assumptions, key processes of influenza dynamics

### Invasion of the pandemic subtype

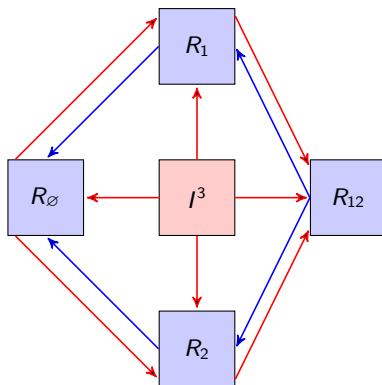

- introduction of the pandemic subtype → co-circulation of three subtypes interacting only via a temporary period of full cross-immunity ( $Q$ ); no co-infections

## Model (1): main modelling assumptions, key processes of influenza dynamics

Co-circulation of three subtypes

Additional important assumption: **seasonality in transmission** → the transmission parameter has a sinusoidal formulation

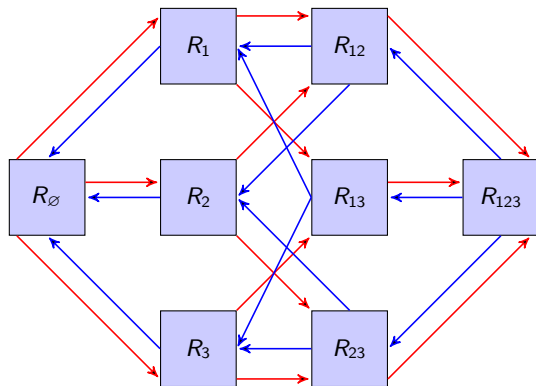

## Model (2): network

Metapopulation of 52 major cities in the world

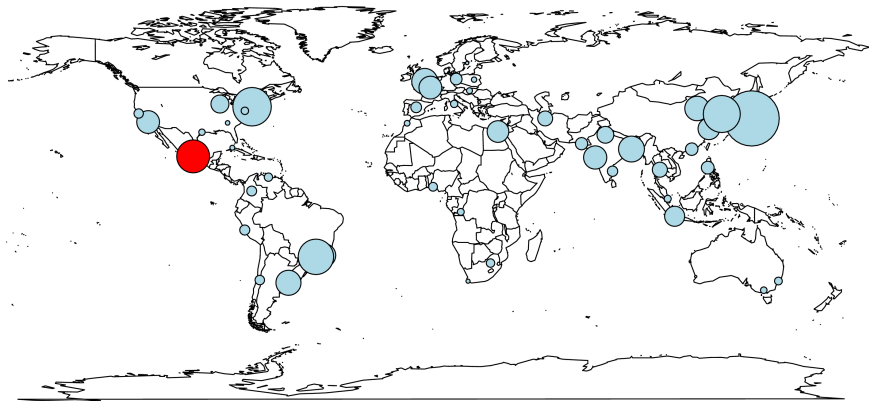

## Model (2): network

### Metapopulation of 52 major cities in the world

- coupling of local dynamics through transportation flows (daily air passengers) → weighted network of mean degree of connectivity=8 (838 connexions / 2652)

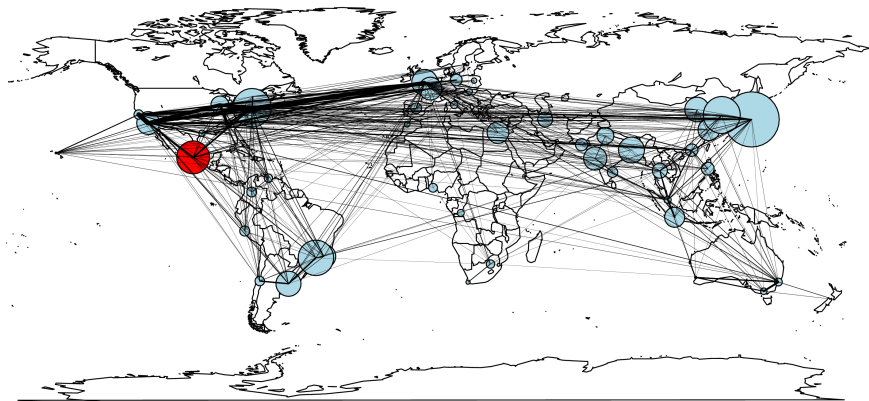



## Model (2): network

### Metapopulation of 52 major cities in the world

- initial node: Mexico City, on 1st April

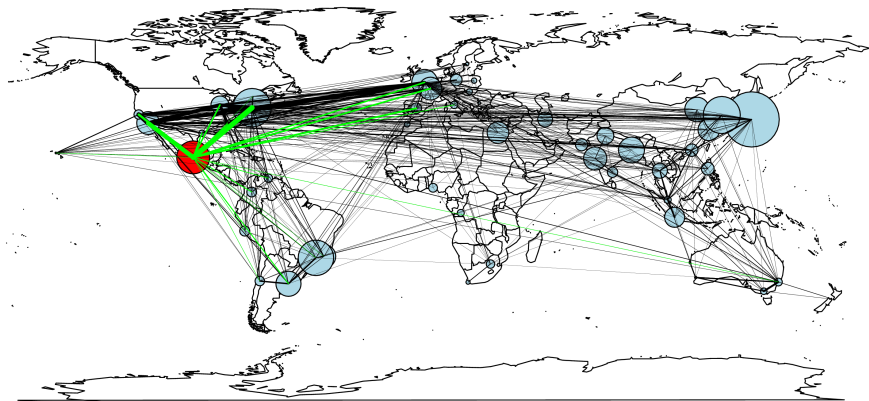



## Model (4): technical aspects

Stochastic model in continuous time, Markovian transitions

### Levels of heterogeneity and complexity

- *HB* formulation
- three strains
- three age classes
- network of cities

Simulations performed using an Euler-multinomial approximation (Breto *et al.*, Ann App Stat 2009)

Number of state variables:  $A * C * (4 * n * 2^{n-1} + 2 * 2^n) = 3 * 52 * 64 = 9984$   
where  $A$  is the number of age classes,  $C$  the number of cities in the network,  $n$  the number of strains

## Model (5): simulation of the continuous time Markov chain via the limit of coupled discrete-time multinomial processes with random rates

Breto *et al.*, Ann App Stat 2009

$X(t) = (X_1(t), \dots, X_c(t))$  is the vector-valued process denoting the (integer or real-valued) counts in each of  $c$  compartments.  $X_i(t) = X_i(0) + \sum_{j \neq i} N_{ji}(t) - \sum_{j \neq i} N_{ij}(t)$

- 1 Divide the interval  $[0, T]$  into  $N - 1$  intervals of width  $\delta = T/N$
- 2 Set initial value  $X(0)$
- 3 FOR  $n = 0$  to  $N - 1$
- 4 Generate noise increments  $\{\Delta\Gamma_{ij} = \Gamma_{ij}(n\delta + \delta) - \Gamma_{ij}(n\delta)\}$
- 5 Generate process increments  $(\Delta N_{i1}, \dots, \Delta N_{i,i-1}, \Delta N_{i,i+1}, \dots, \Delta N_{ic}, R_i)$  from Multinomial( $X_i(n\delta), p_{i1}, \dots, p_{i,i-1}, p_{i,i+1}, \dots, p_{ic}, 1 - \sum_{k \neq i} p_{ik}$ ) where  $p_{ij} = p_{ij}(\{\mu_{ij}(n\delta, X(n\delta))\}, \{\Delta\Gamma_{ij}\})$  is given below
- 6 Set  $X_i(n\delta + \delta) = R_i + \sum_{j \neq i} \Delta N_{ji}$
- 7 END FOR

$p_{ij} = p_{ij}(\{\mu_{ij}(t, x)\}, \{\Delta\Gamma_{ij}(t)\}) = (1 - \exp\{-\sum_k \mu_{ik} \Delta\Gamma_{ik}\}) \mu_{ij} \Delta\Gamma_{ij} / \sum_k \mu_{ik} \Delta\Gamma_{ik}$   
 $R_i$  counts remaining in compartment  $i$  during the current increment

# Analysis of simulations

## Exploration of large ranges of values for

- the basic reproductive number,  $R_0$
- the antigenic drift rate,  $1/D$
- the susceptibility  $\sigma$  of specific age-classes to the new subtype

in terms of most likely event (on average) after the introduction of a new subtype in a two-subtype system at equilibrium (i.e. for each parameter combination, the proportion of trajectories leading to a specific outcome: coexistence, replacement, etc)

# Analysis (1): probability of persistence or replacement

## Preliminary study

- important to account for **co-circulation** processes
- the impact of  $R_0$ ,  $D$  and **seasonality** on invasion and replacement strongly depends on the number of subtypes in competition

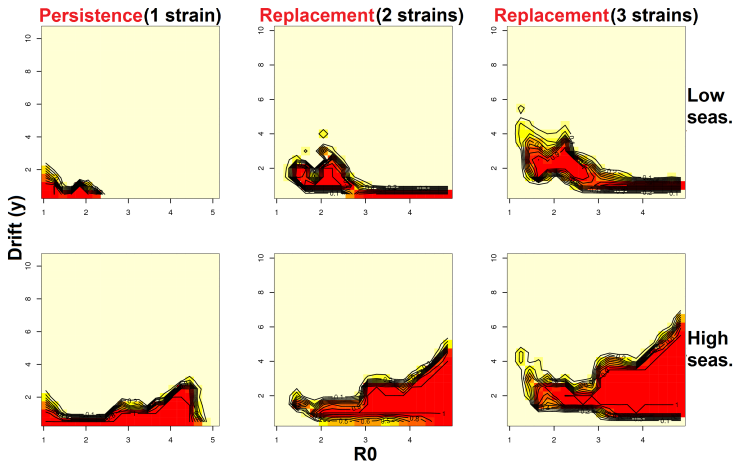

## Analysis (2): $R_0$ fixed, $D$ variable

Distinct regions in parameter space corresponding to several outcomes

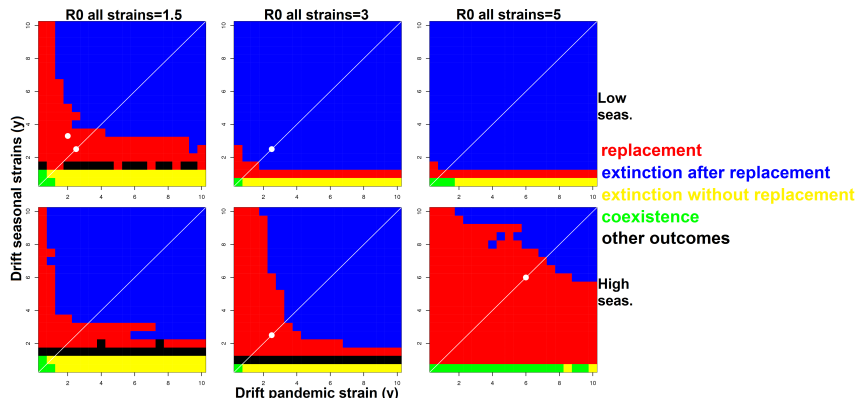

- **replacement** obtained for plausible ranges of parameter values:  $R_0 = 1.5$ ,  $D = 3y$ , low seasonality
- large area of **replacement** for  $R_0 = 5$  and high seasonality (counterbalancing mechanisms)
- **extinction after replacement** obtained for large ranges of parameters: (?) need of additional immunity based mechanisms

# Analysis (3): trajectories of global incidence dynamics for realistic parameter values → replacement

Plausible patterns in terms of peaks succession and amplitude

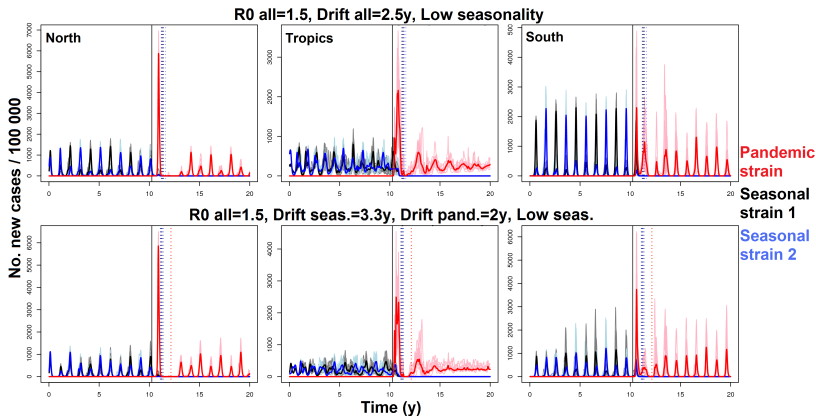

- **replacement** of the seasonal subtypes by the new pandemic subtype
- two pandemic waves in Southern hemisphere, one large wave in Northern zones followed by a refractory period



## Analysis (4): other trajectories of global incidence dynamics

Various patterns in terms of peaks succession and amplitude and with respect to the geographic zone

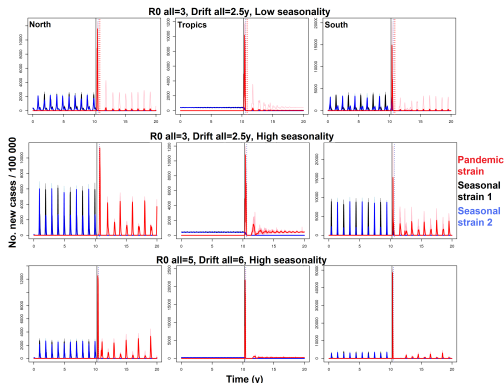

- for high  $R_0$  and low seasonality: depletion of susceptibles after the first epidemic wave leading to quasi-extinction
- the high seasonality: (i) stops the transmission and prevents susceptibles pool exhaustion, (ii) has an impact on the initial conditions of the new sub-type emergence

## Analysis (5): $R_0$ variable, $D$ fixed

No distinct trend in outcomes

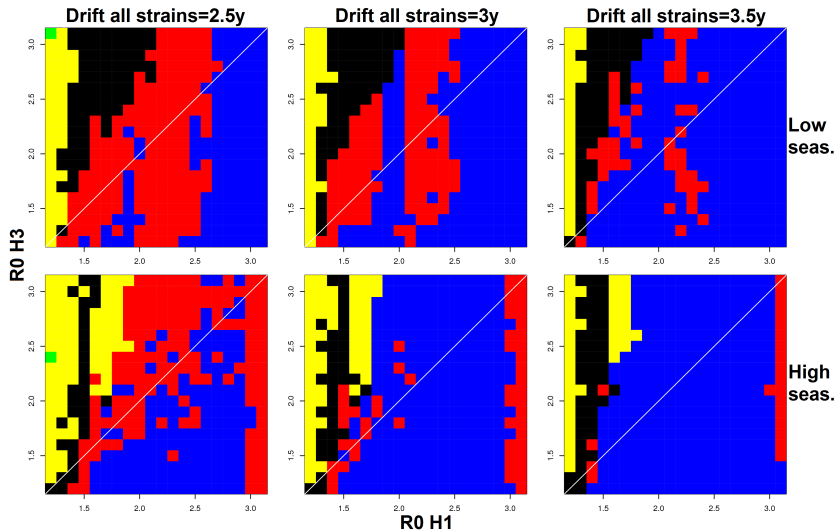

- replacement could occur even for a new subtype with a smaller  $R_0$

## Results (6): $R_0$ and $D$ fixed, Age susceptibility variable

Majority of extinctions without replacement but also successful replacement

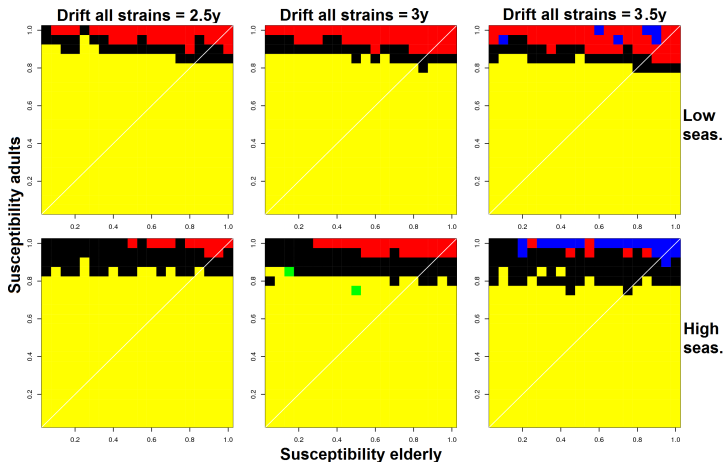

- **replacement** could occur for different values of susceptibility of elderly given that adults are completely susceptible

## Results (7): trajectories of global incidence dynamics → coexistence

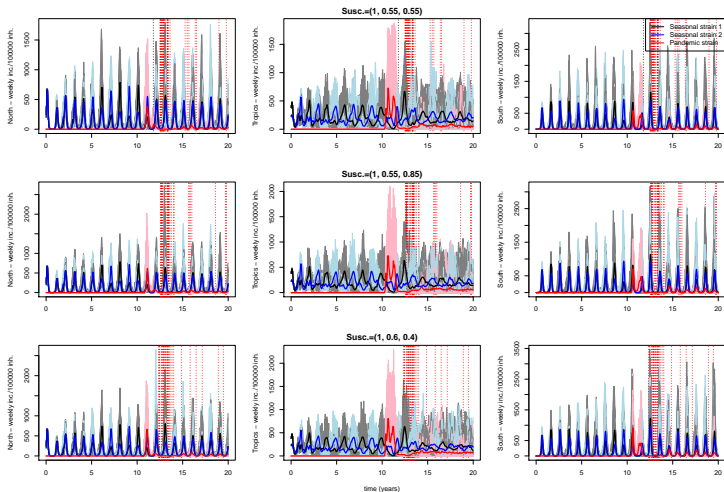

- Unrealistic low level of the new subtype in the next seasons following introduction ?

## Discussion (1)

### Interpretation of the replacement dynamics of the new influenza virus with regard to $R_0$ and antigenic drift

- impact of seasonality in transmission on both the initial emergence conditions for the pandemic subtype and the magnitude of the first epidemic wave
- replacement obtained for  $R_0$  around 1.5, a value consistent with recent estimations (Fraser *et al.*; Yang *et al.*; Science 2009)
  - ▶ for a rapidly evolving new subtype ( $D < 1y$ ) whatever the antigenic drift rate of seasonal subtypes
  - ▶ for realistic antigenic drift rates ( $D$  around 3-4y)
- importance of the temporary full cross immunity in regulating the susceptible pool size
  - ▶ if the seasonal subtypes circulation results in a large proportion of hosts with temporary full cross immunity, a new pandemic subtype can never invade (low  $D_{seasonal}$ )
  - ▶ on the contrary, a too low proportion of hosts with temporary full cross immunity results in successful invasion but followed by a post-pandemic extinction
  - ▶ an appropriate balance is necessary to obtain replacement

## Discussion (2)

For most realistic area of parameters space, successful invasion implies replacement, but often replacement is followed by extinction

Additional mechanisms can reduce the post-pandemic extinction risk

- boosting effect of immunity: reduction of the refractory period following the first pandemic wave
- long term immunity only after multiple infections: avoids the depletion of the susceptibles pool

Introduction of a correction term (possible overestimation of incidences and underestimation of replacement) in the Euler-multinomial approximation: simulations are still running

Euler-multinomial approximation: consider discrete-time multinomial processes with random rates to incorporate environmental stochasticity

More systematic and designed numerical exploration