



HAL
open science

**Euro-Mediterranean Wildland Fire Laboratory, a “ wall-less ” Laboratory for Wildland Fire Sciences and Technologies in the Euro-Mediterranean Region.
EUFIRELAB: Les Vignières facilities: presentation
(intermediate 1)**

Jean-Luc Dupuy, Joel Marechal, Denis Portier, P. Vachet, J-Charles Valette

► **To cite this version:**

Jean-Luc Dupuy, Joel Marechal, Denis Portier, P. Vachet, J-Charles Valette. Euro-Mediterranean Wildland Fire Laboratory, a “ wall-less ” Laboratory for Wildland Fire Sciences and Technologies in the Euro-Mediterranean Region. EUFIRELAB: Les Vignières facilities: presentation (intermediate 1). [Contract] 2004. hal-02830402

HAL Id: hal-02830402

<https://hal.inrae.fr/hal-02830402>

Submitted on 7 Jun 2020

HAL is a multi-disciplinary open access archive for the deposit and dissemination of scientific research documents, whether they are published or not. The documents may come from teaching and research institutions in France or abroad, or from public or private research centers.

L'archive ouverte pluridisciplinaire **HAL**, est destinée au dépôt et à la diffusion de documents scientifiques de niveau recherche, publiés ou non, émanant des établissements d'enseignement et de recherche français ou étrangers, des laboratoires publics ou privés.



EUFIRELAB
EVR1-CT-2002-40028

D-07-02

<http://eufirelab.org>

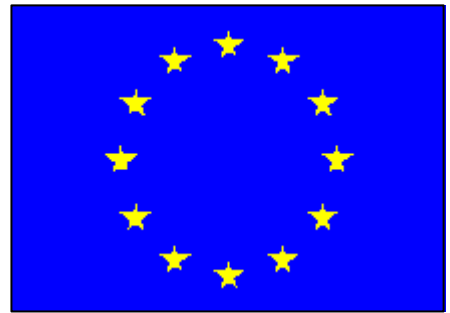

EUFIRELAB:
Euro-Mediterranean Wildland Fire Laboratory,
a “wall-less” Laboratory
for Wildland Fire Sciences and Technologies
in the Euro-Mediterranean Region

Deliverable D-07-02

Les Vignières facilities:

presentation (intermediate 1)

Jean-Luc DUPUY, Joël MARECHAL, Denis PORTIER, Philippe VACHET,
Jean-Charles VALETTE

May 2004

CONTENT LIST

Summary 1

Glossary 1

List of associated documents 1

1 Objectives 2

2 The building 3

 2.1 Outside presentation 3

 2.2 Inside presentation 3

 2.2.1 View from above 3

 2.2.2 Section following the South – North axis 5

 2.2.3 Section following the West-to-East axis 7

 2.3 Fire safety 7

3 The static fire experimental bench 8

 3.1 Objective 8

 3.2 Description 8

 3.3 Illustrations 9

4 The experimental bench for moving fire 11

 4.1 Objectives 11

 4.2 Description 11

 4.3 Illustrations 12

5 Data acquisition system 14

6 Video images acquisition system 15

7 Infrared images acquisition system 16

8 Meteorological data acquisition system 18

 8.1 The portable weather station 18

 8.2 The sensors 19

 8.3 Data logger Campbell CR10X 20

9 Computing network 21

 9.1 Internal network 21

 9.2 Connection with the INRA main server 22

 9.3 Internet connections 22

SUMMARY

This document presents the different components of the research infrastructure developed by INRA-PIF in Les Vignères, dedicated to laboratory studies of wildland fire behaviour and largely opened to INRA-PIF partners in national or international co-operation.

It describes shortly:

- the building itself and its internal organisation,
- the experimental bench dedicated for static fires,
- the experimental bench dedicated for moving fires: DESIRE,
- the National instruments data acquisition system,
- the video images acquisition system,
- the FLIR infra red images acquisition system,
- the meteorological data acquisition system, and
- the computing network.

More accurate description of the components, and procedure are available in Deliverable D-07-09

GLOSSARY

None

LIST OF ASSOCIATED DOCUMENTS

None

1 OBJECTIVES

One of the major research theme of INRA.AV.PIF is to design and develop behaviour models of wildland fire.

These models are based on a complete physical approach of the phenomena.

The research activities include the development and implementation of sub-models dedicated to specific parts of the phenomena.

These models permit to simulate the wildland fire behaviour in a two-dimensional space (vertical plan): the wildland fire propagates in a complete fuel bed (all the vegetation strata from the litter to the tree canopies are represented) located in the stand and on the interface.

In order to improve the predictive abilities of these models and to validate their predictions, the research team needs to carry out specific well-documented experiments under laboratory conditions.

Therefore, the team has built and equipped a specific research infrastructure dedicated to laboratory studies of fire behaviour in Les Vignères in which INRA-PIF gathers all its experimental devices and equipment.

INRA-PIF was able to develop Les Vignères infrastructure during the last fifteen years, thanks national and European contracts, mainly those supported by the General Directorate for Research during the 3rd, 4th and 5th frameworks programmes.

It is the most important research infrastructure dedicated to wildland fire existing in our Institute, largely open to all the INRA research teams.

Since the creation of the Scientific Interest Group "Wildland fires", it is also open to the personnel of the partners.

Finally, it is open to the personnel of the co-contractors to European projects such as FIRE STAR.

In the framework of EUFIRELAB, this infrastructure is open to the teams involved mainly in Unit7 dedicated to Fire Metrology.

This document presents rapid overviews of the major equipments of Les Vignères infrastructure.

More accurate technical information, and common procedures are available in Deliverable D-07-09,

2 THE BUILDING

2.1 OUTSIDE PRESENTATION

The following images detail the outside views of the building.

- The Southern view presents from left to right:
- the technical parts (yellow facades) with the outside emergency stairs to access the first floor, the ground floor areas have no windows towards outside the building for safety and operational reasons,
 - the experimental area (white facade) and its main entrance door

- The Western view presents from left to right
- the mobile home for the temporary staff,
 - the two closed storing areas referenced 21 and 23 in the following of this chapter, and the open one (reference 22),
 - the ground floor of the technical part (no windows)
 - the first floor (four windows) corresponding to the observation room and two offices,
 - the upper level of the experimentation area with its polycarbonate windows and its adjustable shutters
 - the smoke exhaust on the top of the roof



Figure 2-1: Southern view



Figure 2-2: Western view

2.2 INSIDE PRESENTATION

2.2.1 View from above

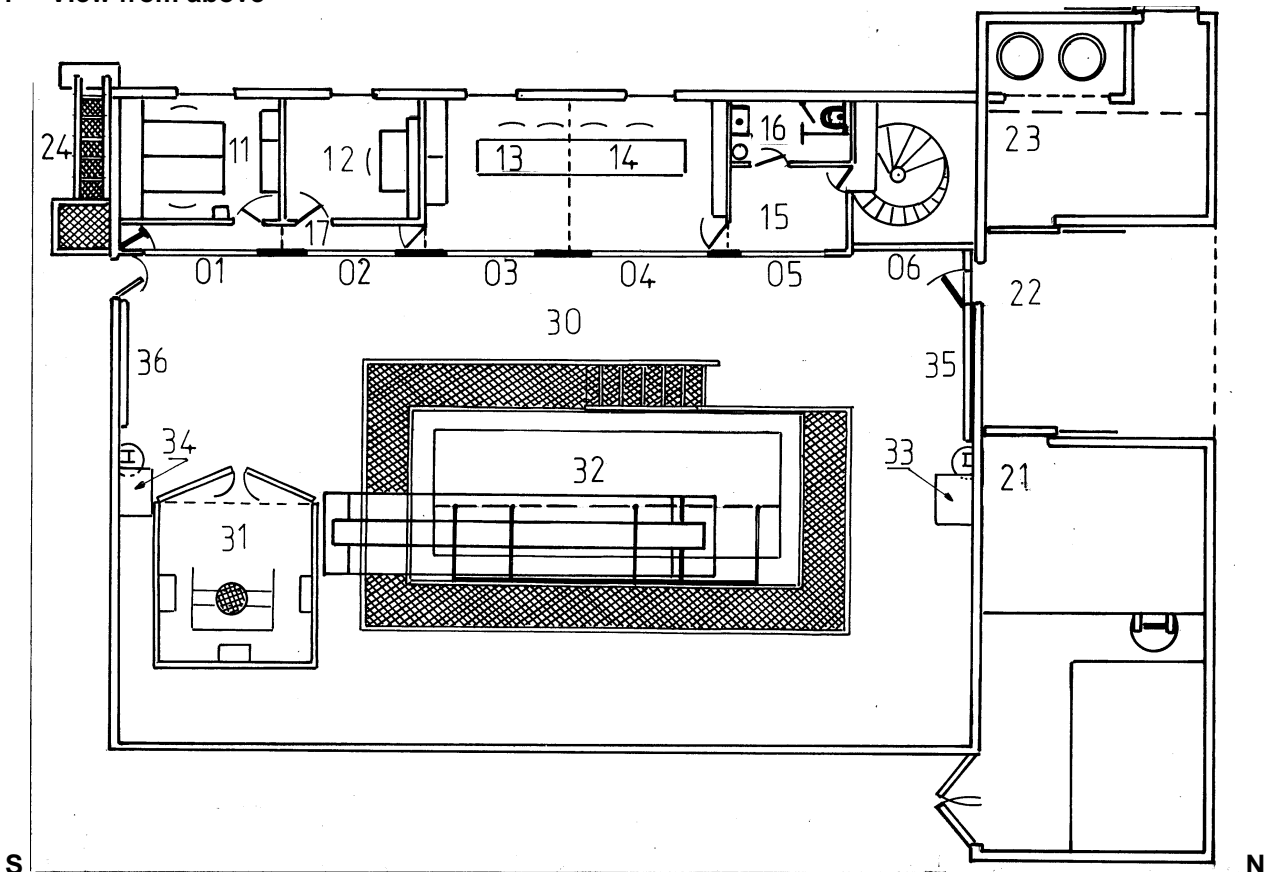

Figure 2-3: View from above

Only the first floor of the technical part of the building is visible on this figure, rooms 01 to 06 are described in the following chapter.

2.2.1.1 Outside the main building

Space 21: Eastern Storing Room

This closed room is dedicated for storing the rough wildland fuel collected under different wildland stands, presently *Pinus pinaster* and *Pinus halepensis*.

A specific area is dedicated for sorting the wildland fuel in order to prepare for the experimental fires pure and homogeneous fuel.

This closed room is equipped with containers for storing the sorted fuel, tools for collecting the fuel and safety installation in case of accidental fire outbreak.

Diverse materials for outside fires are stored in the upper part of this room.

Space 22: Open storing area

This open but covered area is dedicated for downloading or uploading the vans, and cleaning the materials back from the field

Space 23: Western Storing Room

This closed room is dedicated for storing the water station (water supply for the building and safety installation in case of accidental fire outbreak) and devices and tools needed for carrying out fields experiments (water tankers, hand tools, poles,)

2.2.1.2 The experimentation area (30)

This area (length 20 m, width 12 m and height 11 m) is mainly occupied by the major facilities described in the following chapter:

- the bench for static fires: 31
- DESIRE bench for moving fires: 32 described

Two video-cameras (Northern camera 33 and Southern camera 34) permit to monitor the fire behaviour on DESIRE following back view and front view respectively

Two main doors (35 and 36) 4 x 4 m permit the entrance of lorries inside the building itself.

It is illuminated by polycarbonate windows (38) presented in the following chapter.

An adjustable smoke exhaust (25) is located on the roof just above DESIRE bench, presented in chapter 4.

2.2.1.3 The first floor of the technical part

The first floor is accessible by:

- from inside by helicoid stairs (06)
- from outside by the emergency stairs (24)

The first floor is occupied by:

- an office for permanent staff (11)
- an office for temporary staff (12)
- the observation room (13 and 14),
- a corridor (15), the entrance area (17) and part of the observation room permit to following the fire propagation on DESIRE behind a glass wall.

This room is devoted to follow the propagation of the fire on the Desire bench (following internal safety rules, nobody is allowed to stay in the experimental hall during an experimental fire.

It is equipped with data logging systems, and infrared and visible images logging systems.

It is also equipped with selves and metallic cupboards for storing experimental forms and data storage devices (magnetic tapes, CD and DVD in relative safe conditions.

In this room are also all the remote controls for the visible video-cameras, the shutters and the smoke exhaust.

Sanitary equipment is located in area 16.

2.2.2 Section following the South – North axis

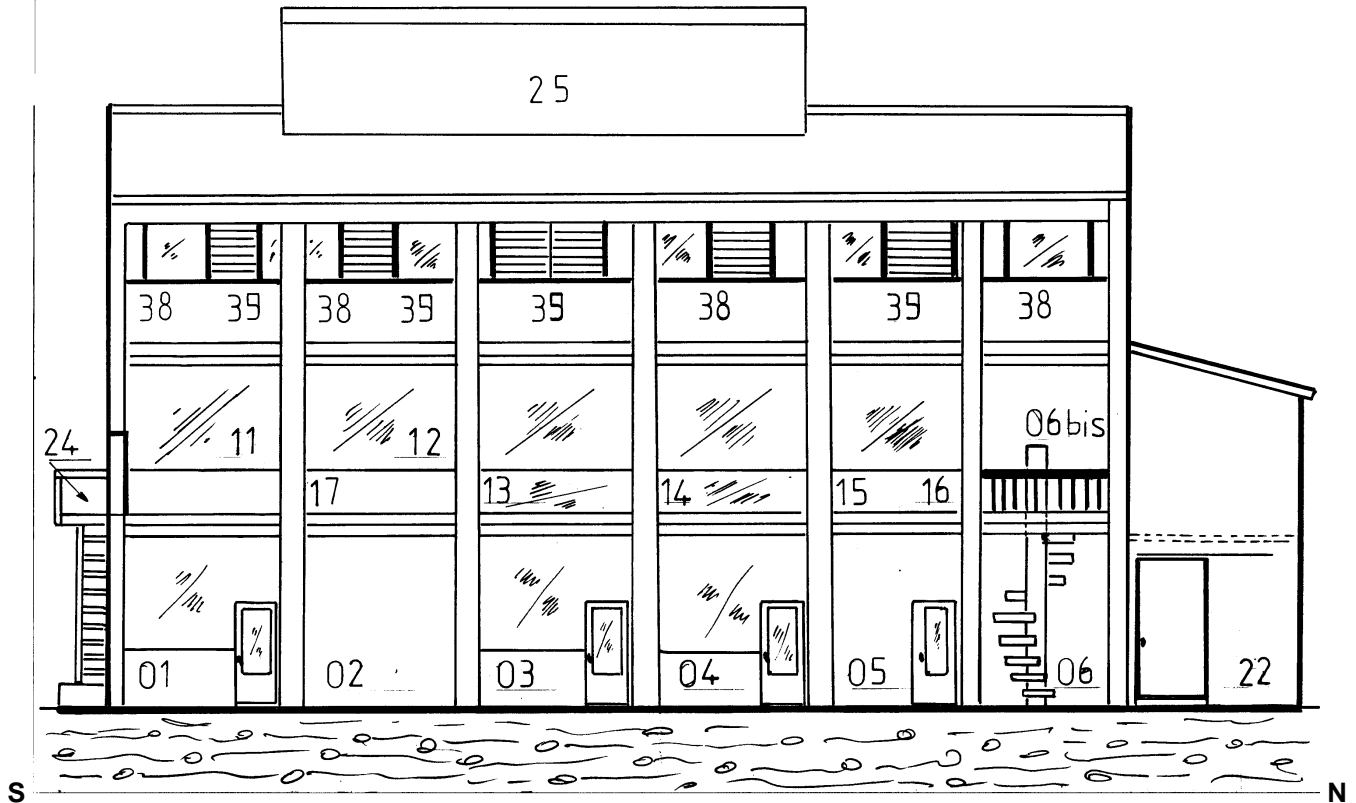

Figure 2-4: Western part of the building

This scheme details the technical parts of the building seen from the experimental hall, following the South-to-North axis.

Parts 22 to 24 have been described in the previous sub-chapter.

2.2.2.1 Ground level

The following rooms and space are at the same level as the experimental hall and open towards it in order to facilitate the work and respect the work regulations and internal safety measures.

Room 01: Drying room

This room is dedicated for determining the wildland fuel moisture content either during the experimental fires or in the framework of wildland fuel description and modelling.

It is equipped by:

- an electric oven-drier (up to 200°C)
- an electronic balance : range 0 to 15 000 g, accuracy 1 g
- an electronic balance: range 0 to 400 g, accuracy 0.001 g
- set of sieves for storing wildland fuel
- an area and diverse tools for sorting the different fuel families (leaves, needles, twigs following their diameter

Room 02: Wildland fuel storing room

This open room is dedicated to the storage of the fuel before the experimental fires in order to equilibrate its moisture content with the air humidity of the experimental hall.

It is equipped with containers of different capacities to store the sorted wildland fire.

Room 03: Electronic room

This room is dedicated to electronic activities, mainly for preparing or repairing thermocouples sensors carried out with threads of different diameter, from 1 mm to 50 μ, which will equipped the experimental benches.

It is equipped by different electronic device and a specific welding machine Soudax SD 100



Figure 2-5: The welding machine Soudax SD 100



Figure 2-6: To weld thermocouple sensors

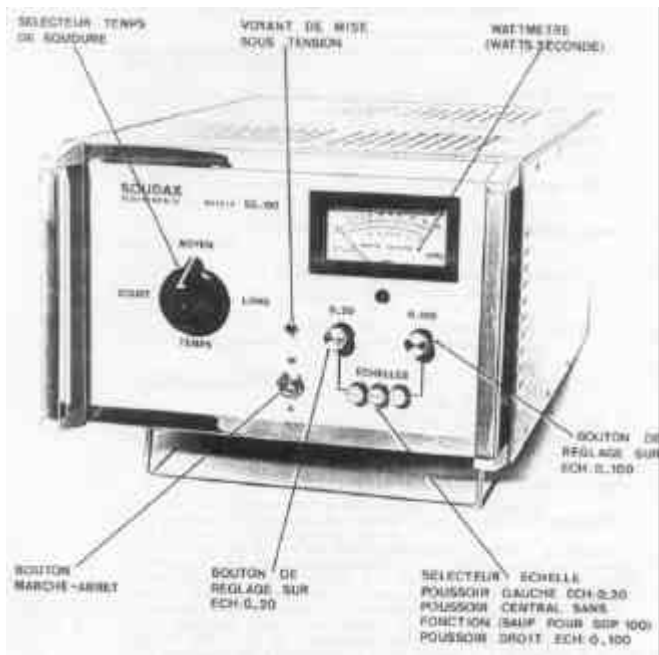

Figure 2-7: Command box of the welding machine Soudax SD100

Selecteur temps de soudure	Select solder time
Bouton marche arrêt	On – off command
Voyant de mise sous tension	On – off light
Wattmètre	Wattmeter
Bouton de réglage, échelle 0 – 20	Adjustment potentiometer, scale 0 – 20
Bouton de réglage, échelle 0 – 100	Adjustment potentiometer, scale 0 – 100
Sélecteur d'échelle	Scale selector

Room 04: Mechanical work room

This room is dedicated to store all the mechanical tools needed for preparing or repairing experimental devices for laboratory and field fires

Room 05: Sanitary equipment

Space 06: Helicoid stairs for accessing to the first floor

2.2.2.2 First floor

Areas 11 to 17 have been described in the previous sub-chapter.

2.2.2.3 Top level

The experimental hall is illuminated by poly-carbonate windows (38)

Adjustable shutters (39) on both side of the experimental hall and the smoke exhaust (25) on its top permit to adjust the air ventilation of the hall without modifying the fire behaviour.

They are under control from the observation room for permitting to adjust them during the tests or in case of emergency.

2.2.3 Section following the West-to-East axis

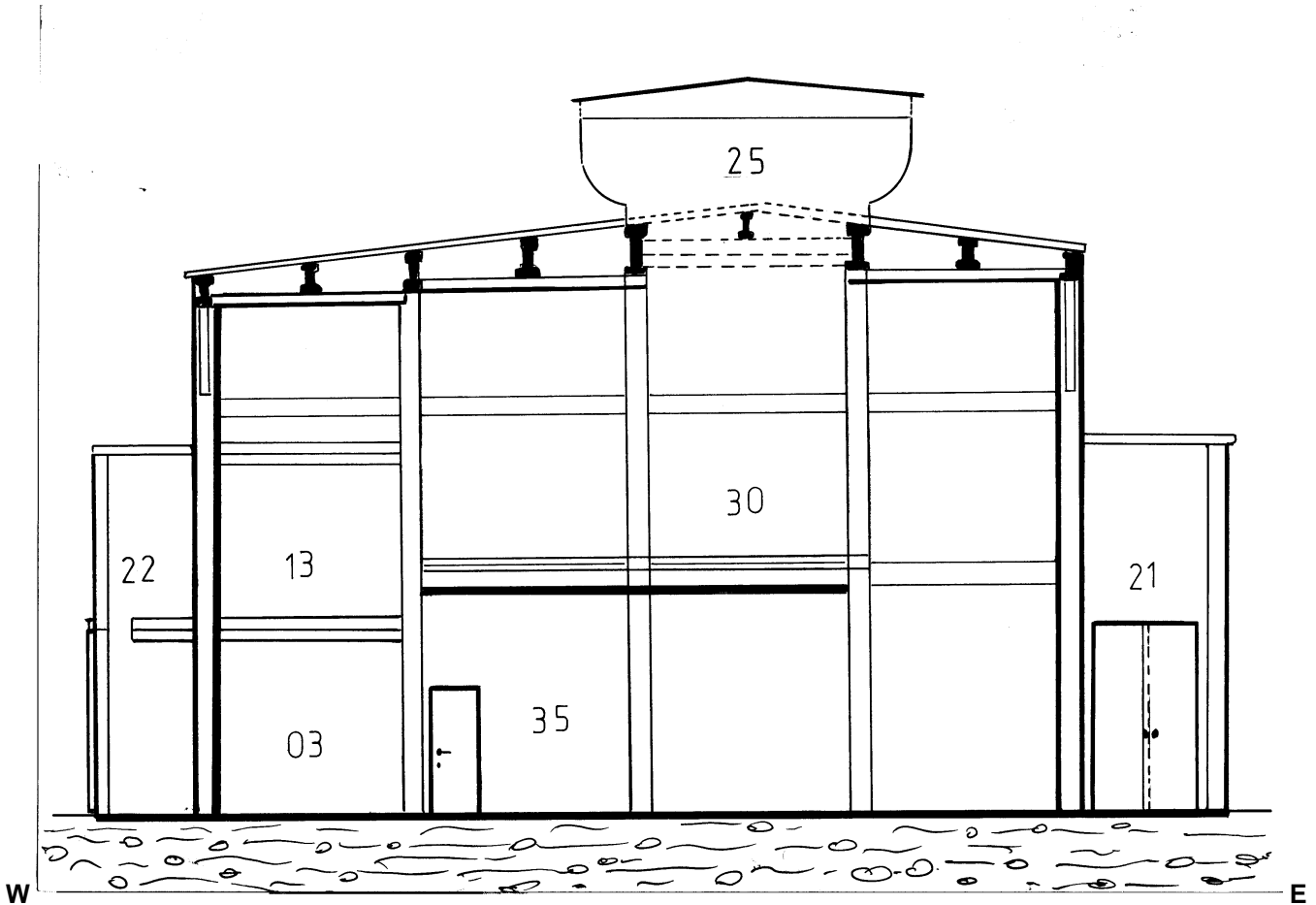

Figure 2-8: Northern part of the building

This figure presents the Northern part of the building:

- behind the experimental area and the technical part, the outside storing areas (21 and 22 and 23 not visible),
- the experimental area itself with its main gates (35 and 36 not visible on this figure),
- the observation room (13) at the first floor of the technical part from which the experimental fires can be observed through the glass wall,
- the electronic room (03) at the ground floor of the technical part is directly connected to the experimental area.

2.3 FIRE SAFETY

Because of the type of laboratory activities carried out inside the building, it is strictly forbidden to smoke in the building and in its annexes.

The building and its annexes are equipped with three permanent fire-hose points (10 bars): Southern and Northern entrance of the experimentation hall and inside the Eastern Storing Room.

Water-pump is directly connected to external electric power supply so that it remains active even if electric power has been cut-off inside the building.

Pipes length and water pressure are high enough to reach the opposite side of the building.

Safety exercises are carried out regularly.

3 THE STATIC FIRE EXPERIMENTAL BENCH

This is one of the two major facility located in the experimentation area (reference 31 in Figure 2-3).

3.1 OBJECTIVE

This facility is dedicated for studying static fire: static means that it does not move in a large spatial scale.

This enables to record data by "fixed" sensors during periods, which are long enough to get a sufficient number of values of each given data.

The bench can be considered like a "burner" limited by the initial amount of fuel.

Its equipment permits to record parameters like:

- temperature variations in diverse locations above the fire, inside and outside the plume,
- energy received in diverse locations by radiation and/or convection,
- vertical component of the gas velocity inside the flame and the plume,
- weigh loss rate of wildland fuel.

Afterwards, these parameters can be related to the wildland fuel characteristics: family, moisture content, load,....

The results obtained on this bench are mainly devoted for:

- verifying assumptions concerning the combustion procedure,
- validating some sub-models dedicated to specific phases of the combustion procedure such as ignition, pyrolysis, .
- comparing with the predictions of behaviour models of wildland fire.

It has been described by DUPUY et al. 2002¹

3.2 DESCRIPTION

Figure 3-1 presents a general view of the static fire bench, Figure 3-2 summarises the principle of this bench and Figure 3-3 focuses on the basket of wildland fuel.

It is included in a 4-m cube:

- the top side is open: the smoke provided during the test exhausts through the smoke exhaust (see 25 on Figure 2-4 and Figure 2-8)
- the front side is transparent (8-mm extruded polystyrene plate) so that fire behaviour can be monitored and video-recorded from outside, a double door (2 x 2 m) also in extruded polystyrene permits to enter the chamber before and after the test
- the three other sides are white woody walls.

Specific components have been carried out for this bench:

- cylindrical metallic baskets for containing the wildland fuel before and during the test,
- adaptable baskets holder
- specific ignition devices
- vertical marks for analysing visible video images

Specific sensors have been developed or adapted for this purpose:

- hot and cold back bodies,
- weighting system
- thermocouples sensors
- connection to the data logging system

All these items are presented in deliverable D-07-09.

¹ DUPUY, JI; MARECHAL, J; PORTIER, D; MORVAN, D , 2002. Fires from a cylindrical forest fuel burner: combustion dynamics and flame properties. 4. International Conference on forest fire research / 2002 Wildland fire safety summit, Luso (PRT), 2002/11/18-23; Millpress, Rotterdam (NLD). Viegas D.X. (ed.), Forest fire research and wildland fire safety. Abstracts book.

3.3 ILLUSTRATIONS

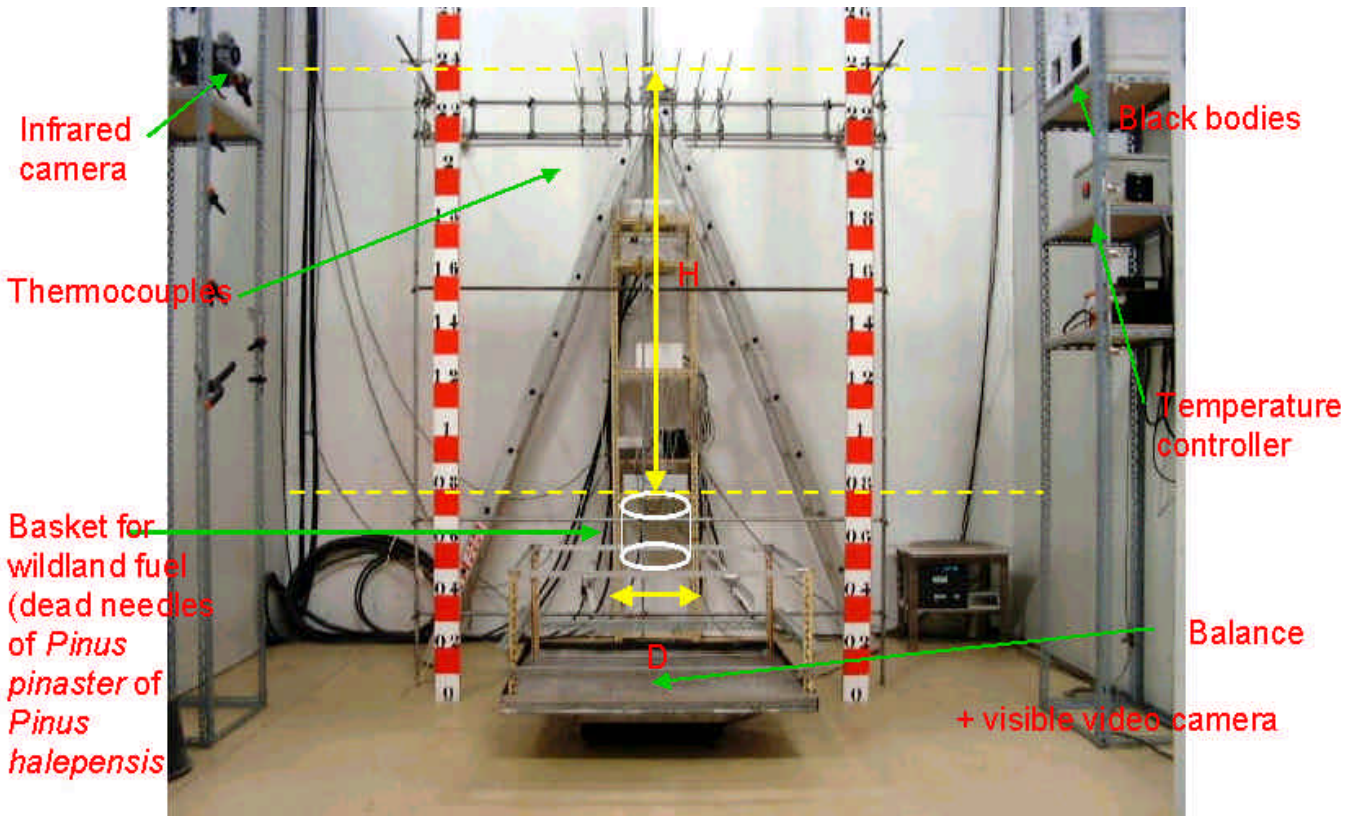

Figure 3-1: General view of the static fire device

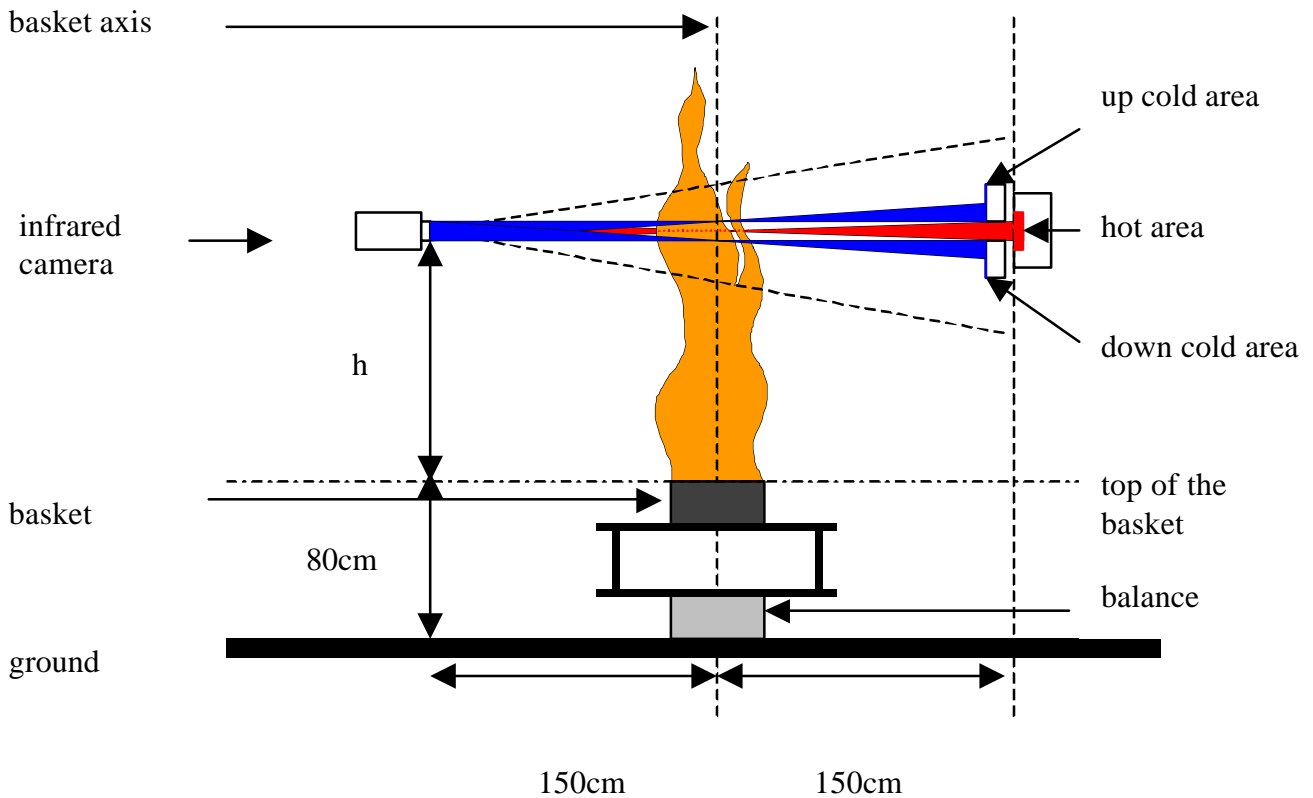

Figure 3-2: Scheme of the experimental device

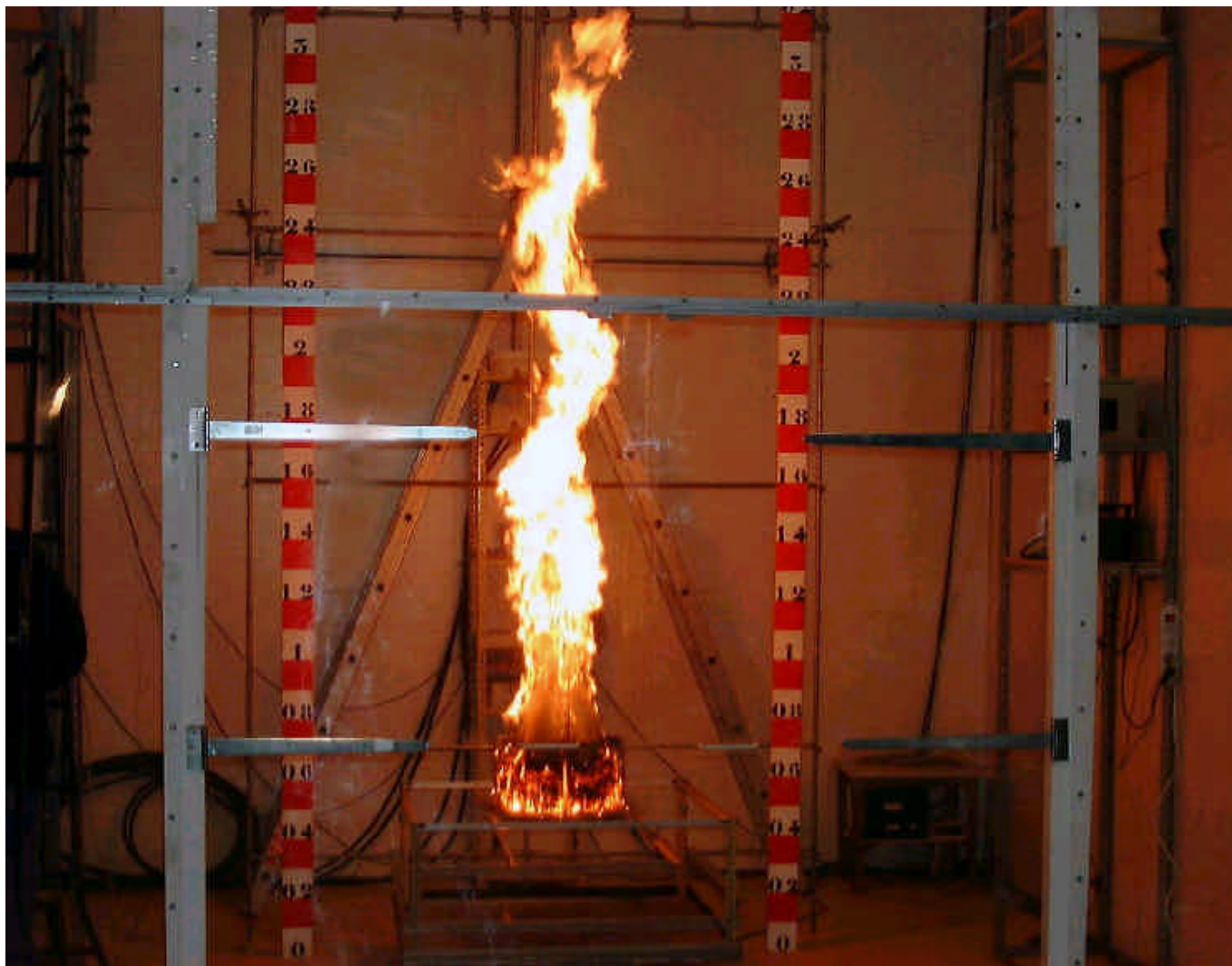

Figure 3-3: Detailed view of the “wildland fuel burner”

4 THE EXPERIMENTAL BENCH FOR MOVING FIRE

This is one of the two major facility located in the experimentation area (reference 32 in Figure 2-3).

4.1 OBJECTIVES

This facility is dedicated to study moving surface fire under laboratory conditions, like the experimental bench for static fire.

Most of the sensors, which equipped this bench, are "fixed" in the sense that they are neither moving with the fire nor following it.

Consequently, each of these sensors delivers data which describe the temporal evolution of the measured parameter in a given location.

For technical reasons and because wind effects were studied by partners like INIA-CIF P010 in Spain and EIPFI-CEREN P017 in France, this bench has been build for studying the slope effect on the fire behaviour:

- no slope as control, the fire dynamic is mainly due to the internal characteristics of the fuel bed: type of fuel, moisture content, load and porosity,
- up-slope, the dynamic of the fire increases due to the fact that the angle between the fire front and the fuel bed is sharper
- down slope: the angle between the fire front and the fuel bed becomes obtuse.

Even if the phenomenon occurs in the three spatial dimensions, one of the objectives is to analyse when:

- the fire remains two dimensional (X direction of fire spreading, Z local vertical) and
- the fire becomes typically three dimensional (Y direction perpendicular to X).

During the 1980's, a fist series of test have been carried out on a small bench which was not adapted to follow and analyse the behaviour of up-slope fire (edges effects and to short duration of the tests).

Consequently, we decided at the beginning of the 1990's to build a larger bench.

During the last period, the studied fuel beds were constituted of dead needles of *Pinus pinaster* or of *Pinus halepensis*, because these two species constitute the larger flammable stands in Southern-East of France.

For a given type of fuel bed, it is possible to study the effects of:

- slope, continuously between -30° and $+30^\circ$
- moisture content, between oven-dried to air-dried fuel,
- load, with a maximum of 3 kg per square meter for security and technical reasons
- ignition method: in one point, or following a line
- width of the fuel bed (in fact length of the fire line).

Other types of fuel should be used without major technical problems, except the possibility to collect and prepare easily the large quantities of fuel needed to carry out these tests.

4.2 DESCRIPTION

Figure 4-1 and Figure 4-2 present two views of the bench itself and the surrounding equipment.

Figure 4-3 details he equipment of the bench.

As indicated in chapter 2.2, DESIRE bench occupies the largest part of the experimental area and fire behaviour is observed from the observation room and the corridor.

Internal, safety rules do not authorise that people remain inside the experimentation hall during a test.

Quite all parts of the bench have been home assembled:

- the platform itself : the metallic structure supports a woody floor and a cellular-concrete floor for ensuring stability and avoiding to artificially pre-heat the fuel
- the surrounding catwalk for permitting the preparation of each test and the cleaning of the platform in complete safety
- the lifting oil jack for tilting the platform at the required inclination, the system is under control in the experimentation hall and in the observation room in case of emergency
- the grid for pointing the base and the tip of the fame (side view) and supporting the thermocouples sensors
- the red and white visible marks for locating as accurately as possible the fire front
- the connections from the thermocouples sensors to the connecting boxes and from these boxes to the data acquisition system
- the third side view video camera
- the tools and systems for spreading fuel, measuring fuel bed depth, following the fire front propagation, evaluating the consumption ratio, collecting burning conditions and determining the fuel moisture content.

All these items are described more accurately in Deliverable D-07-09

4.3 ILLUSTRATIONS



Figure 4-1: General view of the experimental bench for moving fire DESIRE

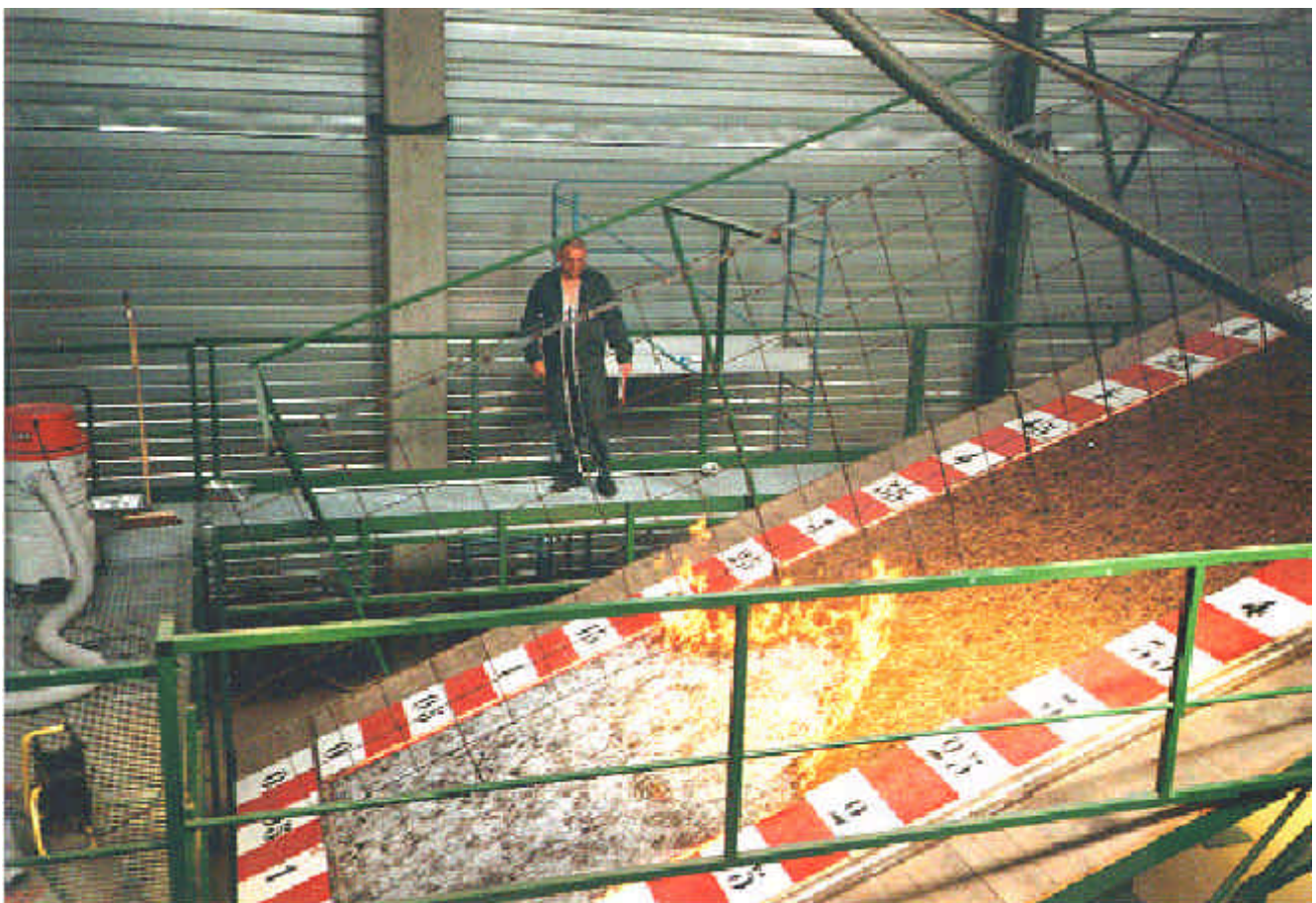

Figure 4-2: Side view of an up-slope the surface fire

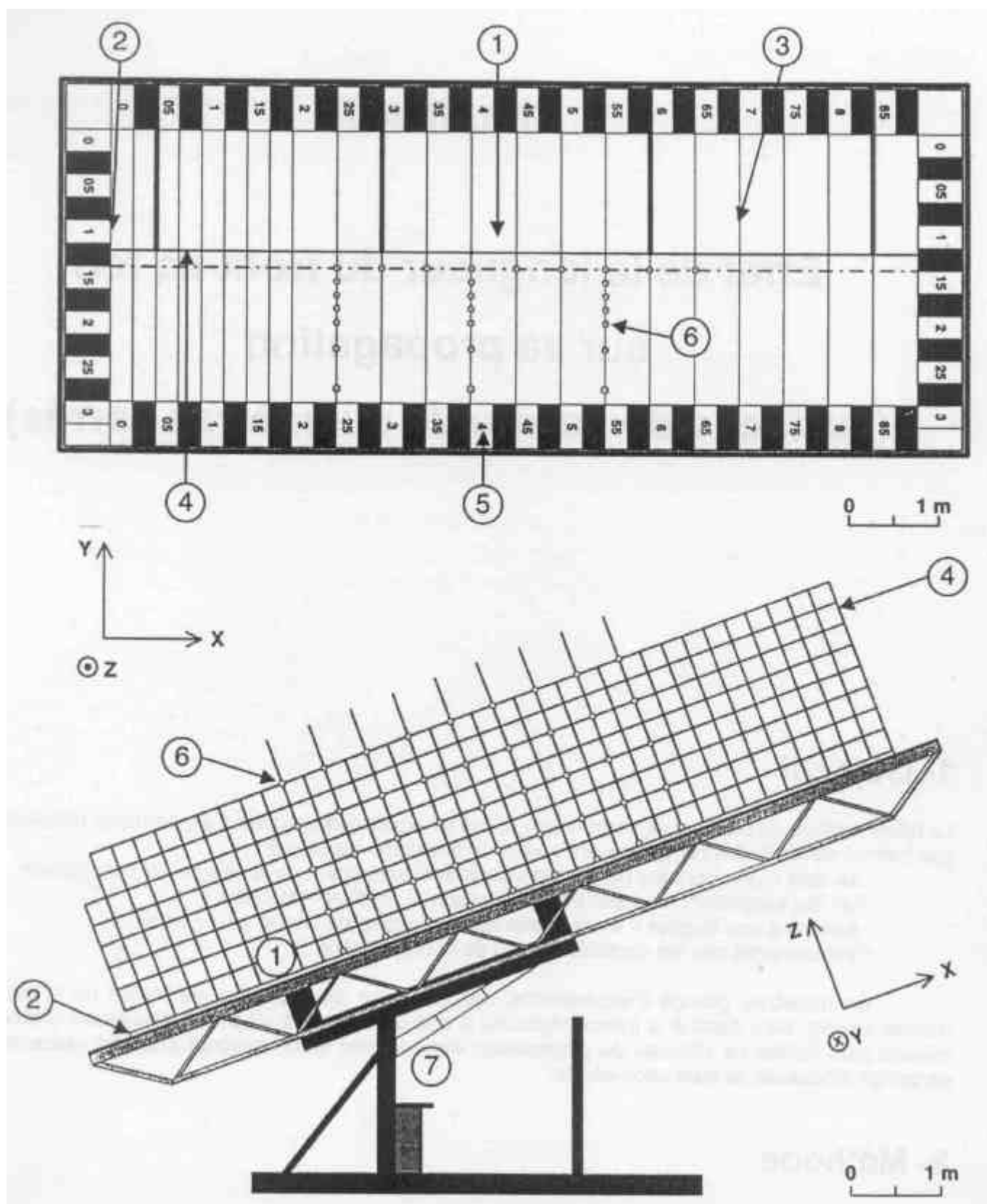

Figure 4-3: DESIRE bench (from Joël MARÉCHAL)

- | | |
|--------------------|-------------------------------------|
| 1 Burning platform | 2 Ignition line (up-slope fire) |
| 3 Cotton threads | 4 metallic grid (25-cm square mesh) |
| 5 Coloured marks | 6 location of thermocouples sensors |
| 7 Lifting oil jack | |

5 DATA ACQUISITION SYSTEM

In order to be able to scan at high frequency the different sensors, which equipped the experimental benches, we progressively substitute the previous ORION data logger by a more flexible National Instruments data acquisition system.

EUFIRELAB project gave us the opportunity to continue.

The National Instruments system presently used in Les Vignères is represented on following figure.

Our system gathers the following components:

- the terminal blocks SCXI 1303, 1321 and 1328
- the signal conditioning modules SCXI 1102/C, 1120 and 1121
- the SCXI-1000 chassis
- the SCXI 1349 shielded cable
- the data acquisition board AT-MOI-16XE-50

The functionality of each of them and their technical information are provided in Deliverable D-07-09.

The following figure present the chassis containing the modules to which two terminal blocks are connected.

SCXI1102C, 1120 and 1121 modules are stored inside the chassis.

SCXI 1349 shielded cable is connected to the rear facade of the chassis.

They are all concealed.

The coloured wires connected the sensors ad transducers to the blocks.



Figure 5-1: SCXI100 chassis, SCXI1321 and 1303 connectors

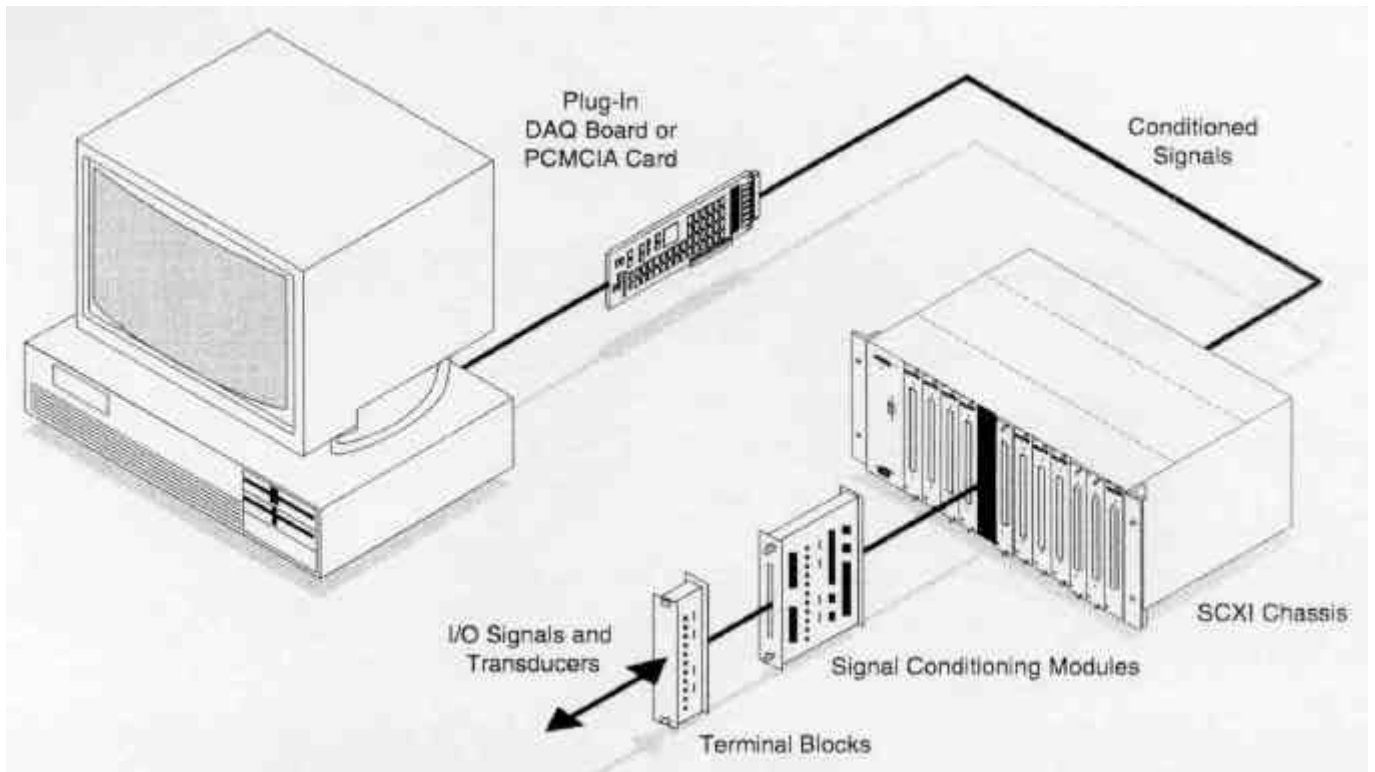

Figure 5-2: The SCXI Signal Conditioning Front-End System for Plug-In Data Acquisition Boards

6 VIDEO IMAGES ACQUISITION SYSTEM

Figure 5-1 presents the scheme of the video network existing in the experimentation area and mainly dedicated to record images of fires spreading on the experimental bench for moving fires

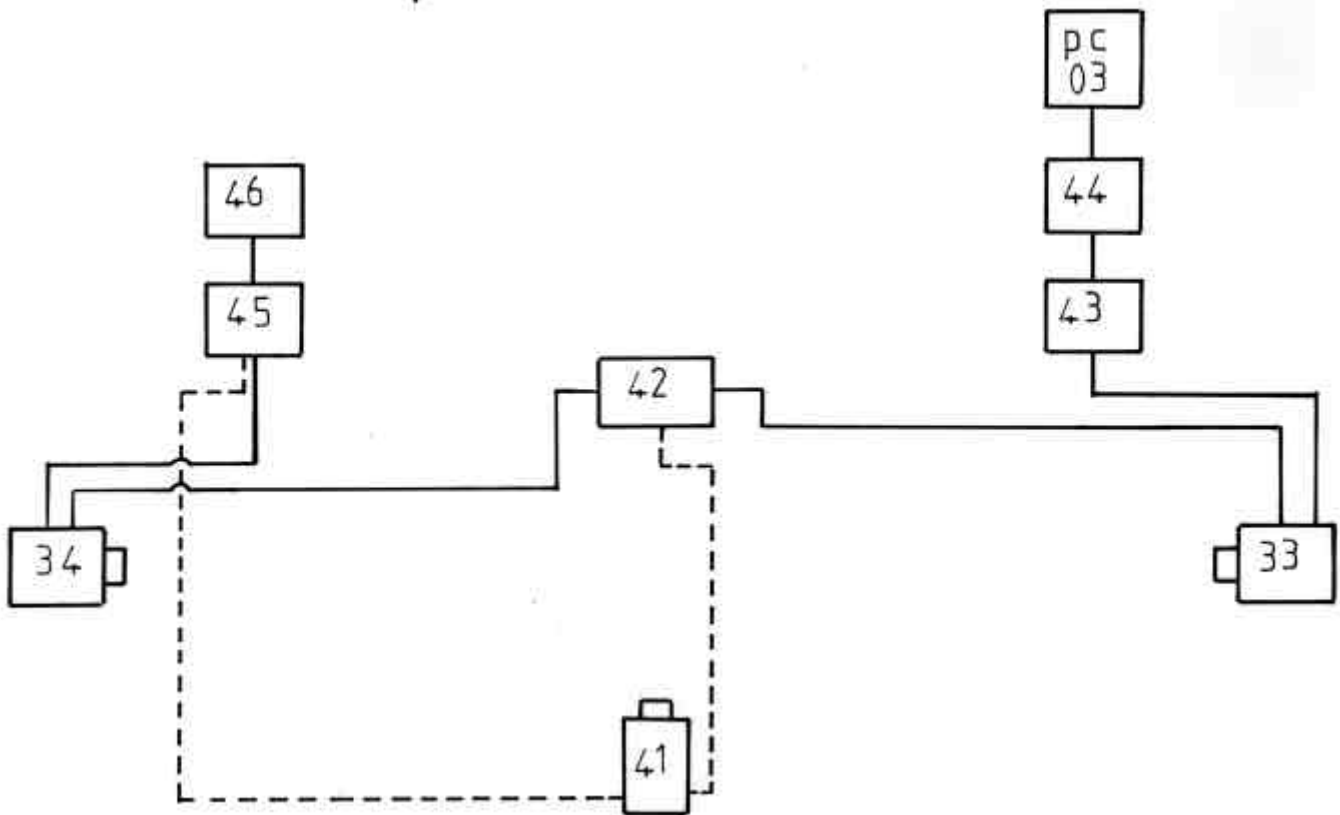

Figure 6-1: Video image network

Description of the part	
33	Northern fixed camera for back view of no-slope or up-slope fires, and front view for down-slope fires
34	Southern fixed camera for front view of no-slope and up-slope fires and back view for down-slope fires
41	Eastern "mobile" camera for side view of no-slope, up-slope or down-slope fires, it can be moved along the main axis of the bench and follow its angle value
42	VT-14A video switch for controlling the pan and tilt movements of the turrets 560 of cameras 33 and 34 by joystick and their zooms, iris and focus by specific keys In and Out (Increase Decrease)
43	Video recorder Panasonic AG-7355-E
45	Video recorder Panasonic AG-7355-E
44	Video monitor Panasonic TC 1470 Y, switch 6 in HI-Z position
46	Video monitor Panasonic TC 1470 Y, switch 6 in 75 Ohms position
PC03	Personal computer dedicated to images digitalisation and treatments

The lines represent permanent linkages, the dash line indicates temporary linkages: for safety reasons the 41 camera is installed each time a test is carried out on the bench.

The Sony SSM-145E dedicated to camera 41 is not represented on this chart: because presently the camera 41 is not remotely controlled.

All technical information on the devices and the procedure of use are included in Deliverable D-07-09

7 INFRARED IMAGES ACQUISITION SYSTEM

We use an infrared camera FLIR SC2000 (see technical specifications and using procedure in Deliverable D-07-09

- IR-detector based on non-cooled micro-bolometer focal plane array (FPA),
- this technology works in the long wave spectral band (7.5 – 13 im spectral range),
- a built-in spectral filter reduces the influence of the atmospheric attenuation,
- the camera has a fully radiometric design with temperature measurement up to 1500 °C,
- three temperature ranges are available: -40° C to +120° C, 0°C to +500°C, 350°C to 1500 °C,
- its 14 bits digital output works in real-time,
- it can be used as a portable handheld camera, tripod mounted, operated locally or by remote control.

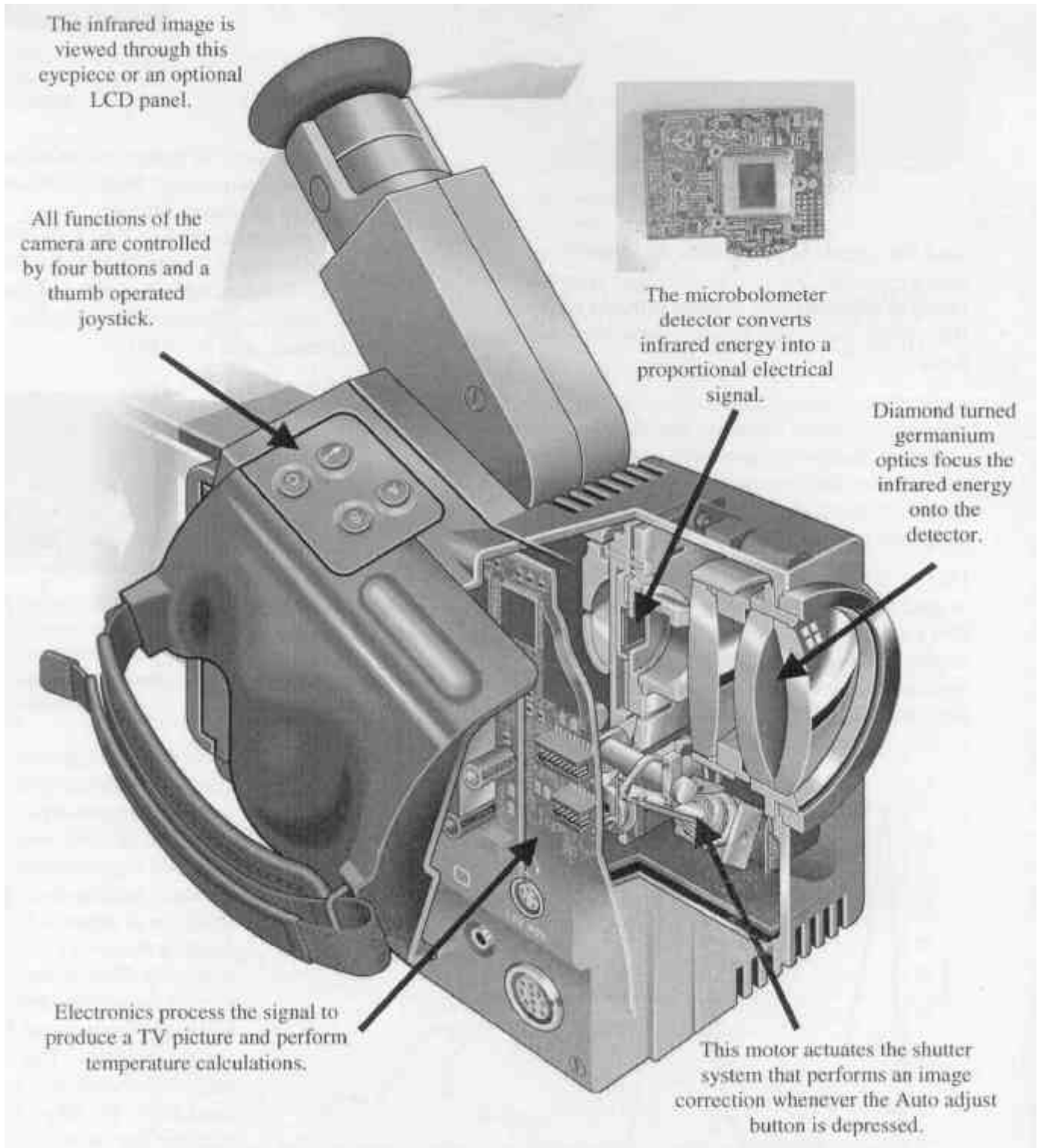

Figure 7-1: SC2000 camera

The Researcher HS system is used to perform high-speed image data acquisition at a sampling rate of 50 Hz.

The software features are the same as ThermoCAM® Researcher but the hardware uses the System parts ThermoCAM® SC Parallel:

- IC2-DIG16 frame grabber (inside the PC) from Imaging Technology Inc., USA
- a PCI-standardised card with a 44-pin DSUB cable fitting into the side of the Parallel Interface (PI) (3)
- a Parallel Interface (PI) 500/900 box (3).
- the PI - Camera Cable fits into the "Camera 500" connector of this box
- the IC2-DIG16 cable fits into the "RS422" connector.
- a serial cable links the desktop computer to the "RS232" connector
- a LEMO connector on the short side fits to a Power Supply 500 unit (5)
- the ThermoCAM® Researcher CD-ROM (not shown) including PC driver software
- a desktop computer (1) with an internal SCSI disk (2) (*external on the image*) for image storage



Figure 7-2: ThermoCAM® Researcher HS - ThermoCAM® SC parallel interface system

More over an extension cable links the camera (installed on DESIRE) to the PC07 (see chapter 8)

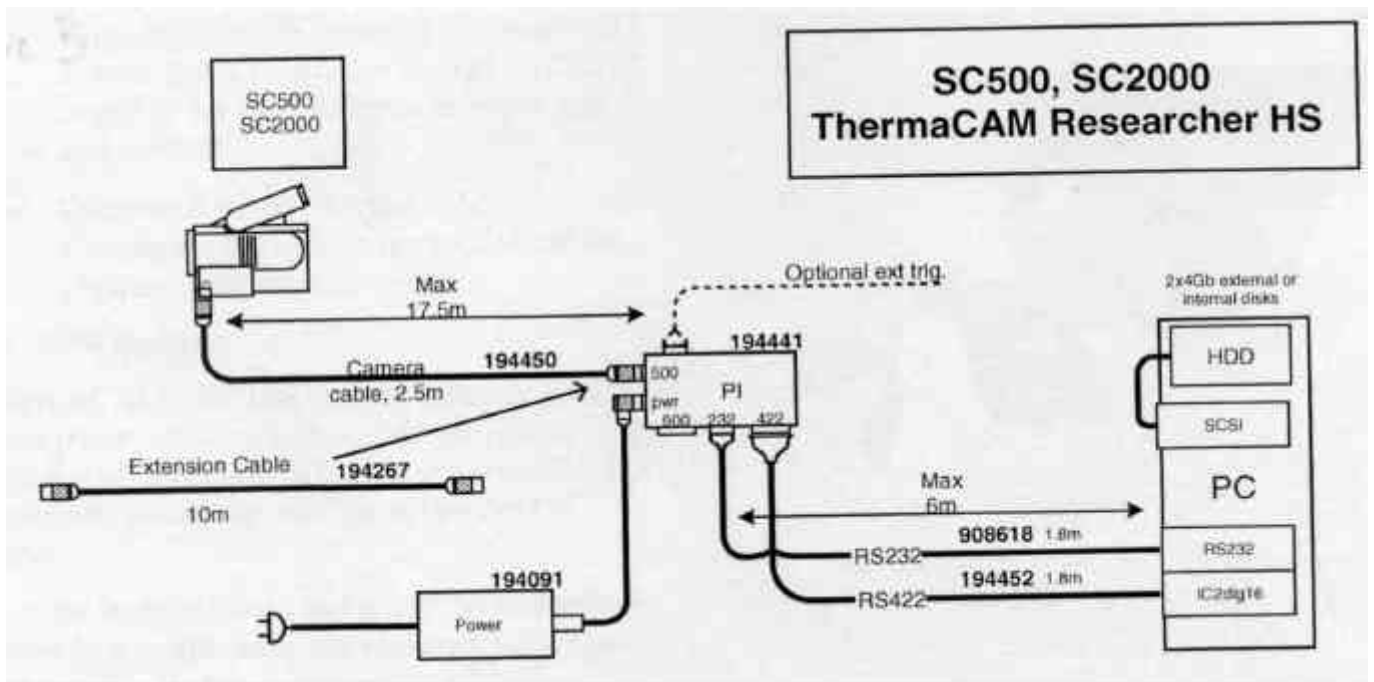

Figure 7-3: SC2000 ThermoCAM Researcher system

8 METEOROLOGICAL DATA ACQUISITION SYSTEM

8.1 THE PORTABLE WEATHER STATION

Since this year and thanks to EUFIRELAB project, the team is now equipped with a portable meteorological data acquisition system presented in figure 7-1 and dedicated to record meteorological parameters during the experimental fires, mainly:

- air temperature and air humidity at 2 m high
- wind direction and wind speed at 1 and 2 m high.

This station is basically constituted by:

- 1: anemometer (wind speed) at 2 m above the ground
- 2: wind vane (wind direction) at 2 m above the ground
- 3: air temperature and air humidity at 2 m above the ground
- 4: solar panel for supplying electric power to the data logger
- 5: data logger and storage device protected
- 6: anemometer (wind speed) at 1 m above the ground
- 7: wind vane (wind direction) at 1 m above the ground
- 8: lap top for programming the data logger and storing the data files.

The air characteristics do not vary so quickly as wind direction and speed (gusts of wind), so the corresponding data are recorded less frequently than the wind characteristics:

- air temperature and air humidity are recorded every 30 seconds during fifteen minutes before and after the experiment in order to determine the mean values of air temperature and air humidity,
- wind speed and direction are recorded every half a second during the complete test.

This "high" frequency permits to identify the periods of time when the fire is strictly driven by the wind (direction of fire propagation and wind direction are identical).

Only the data corresponding to these periods will be used for establishing correlations with fire behaviour.

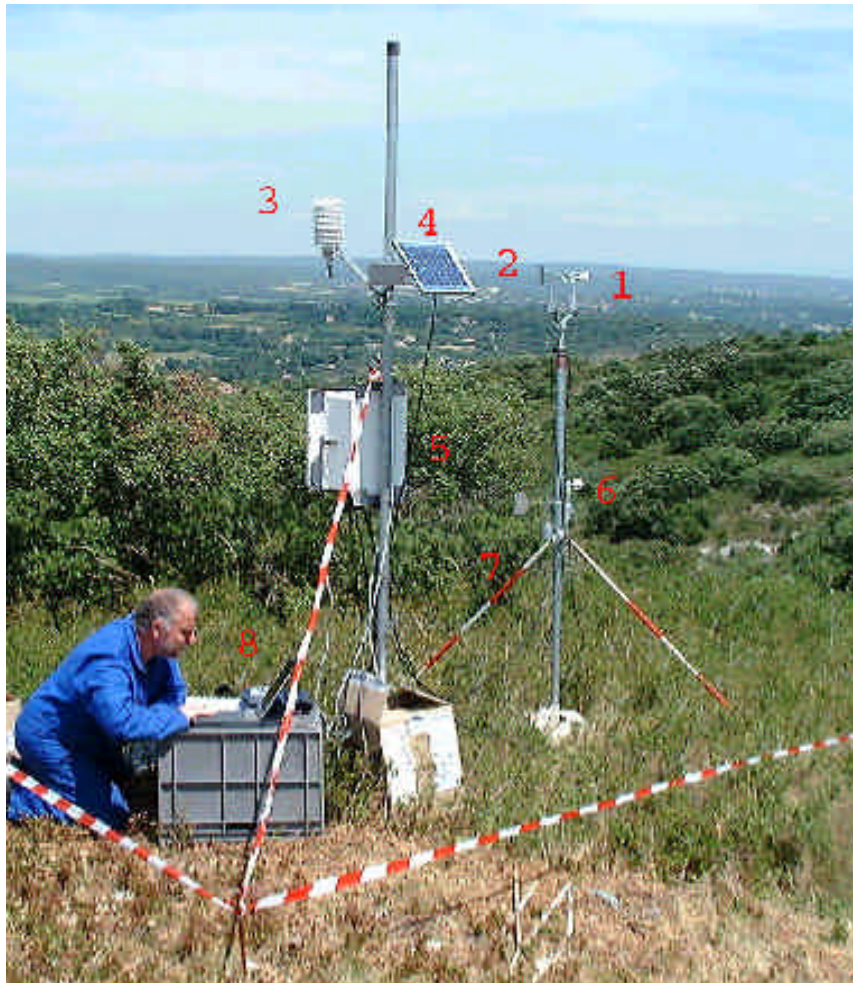

Figure 8-1: The portable weather station, installed close the experimental fire

8.2 THE SENSORS

Technical specifications are available Deliverable D-07-09

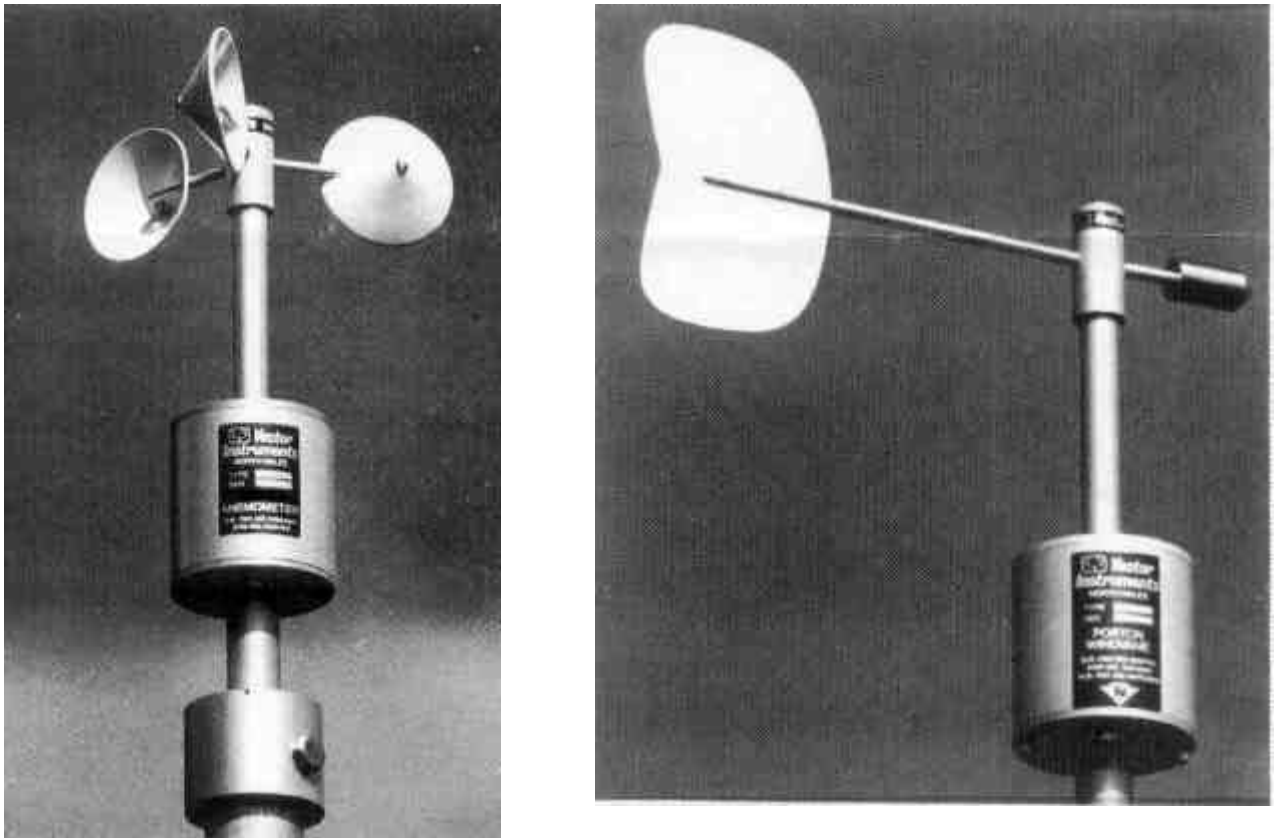

Figure 8-2: Vector anemometer (right) and win vane (rights)

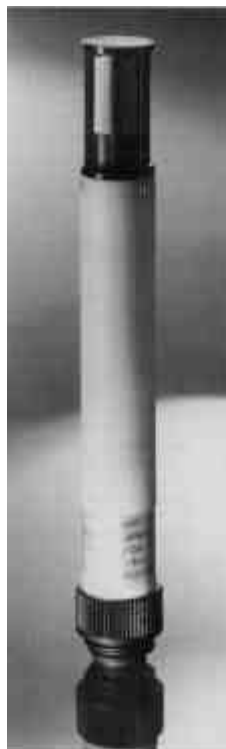

Figure 8-3: Air temperature (RTD Pt 100 1/3 DIN) and humidity (ROTRONIC-HYGROMER C94) sensors

8.3 DATA LOGGER CAMPBELL CR10X

Technical specifications are available Deliverable D-07-09

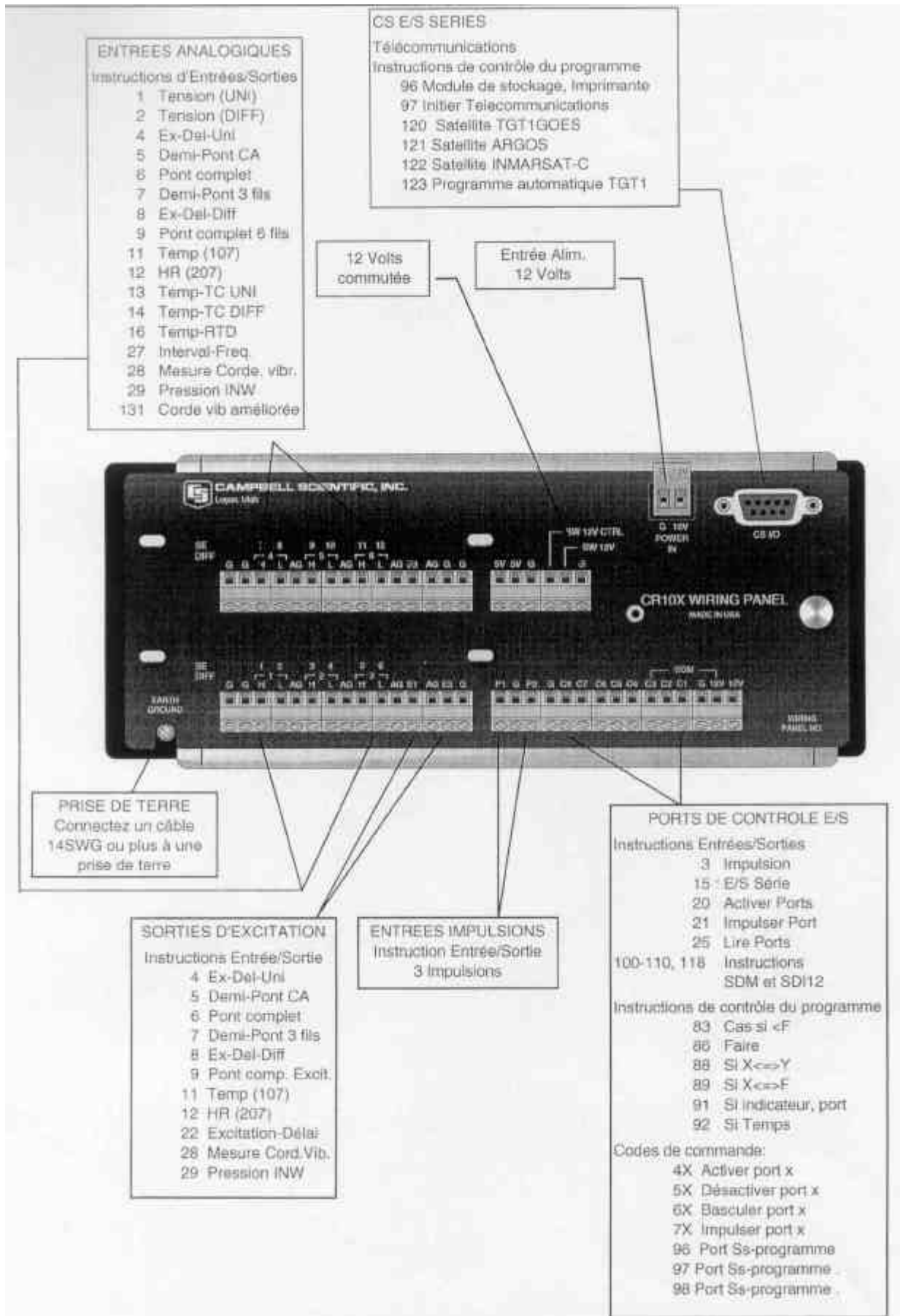

Figure 8-4: Data logger Campbell CR10X

9 COMPUTING NETWORK

9.1 INTERNAL NETWORK

Figure 9-1 presents the internal serial network of personal computers and laptops presently existing. The network is basically constituted with BNC wires, at least one RJ45 junction will be installed in the next future.

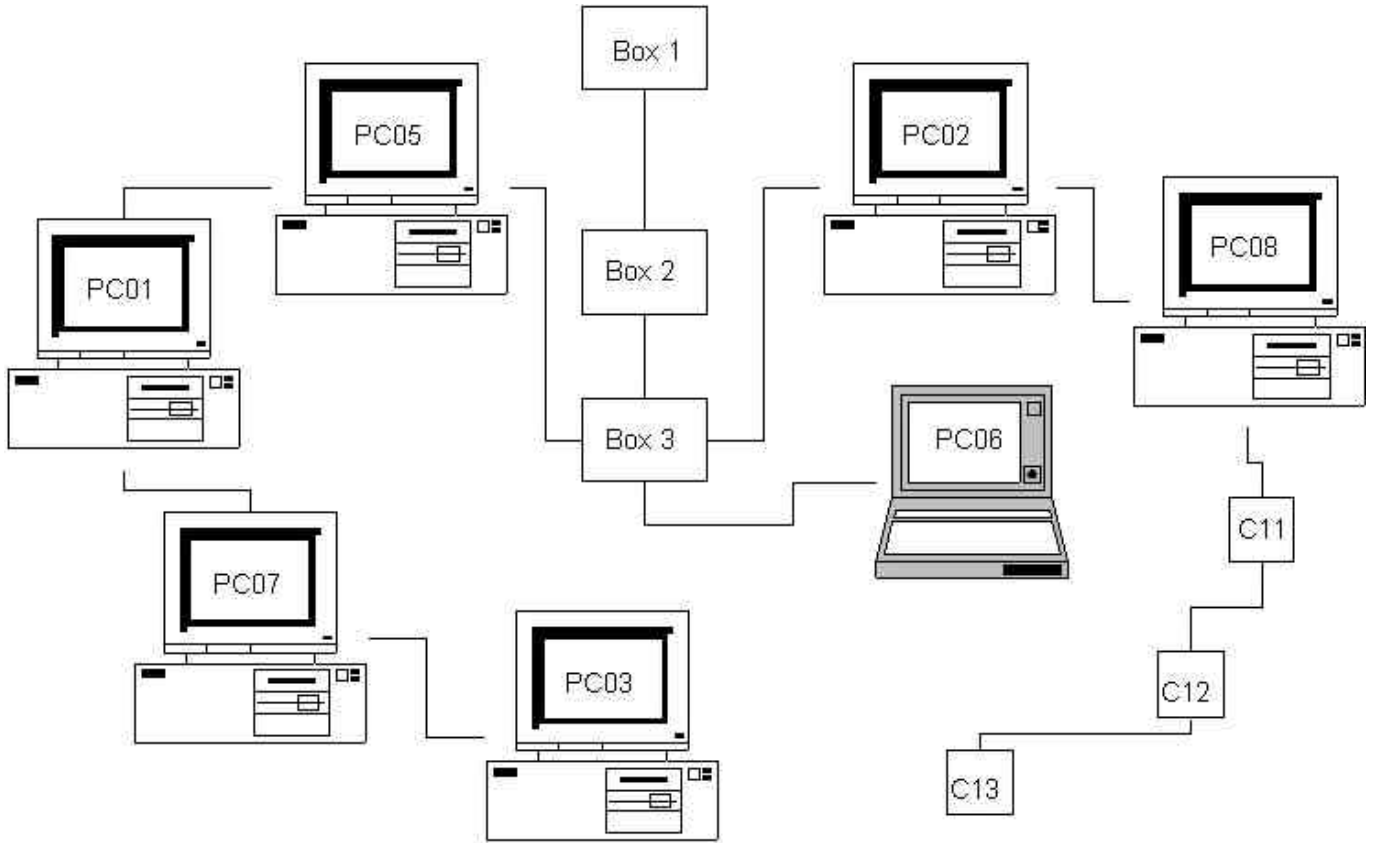

Figure 9-1: Internal computing network

Box 1	Numeris box TRN 4GEPS	Connection to the telephone network connected with the specialised server of INRA centre, dedicated to connections with remote laboratories located outside the centre
Box 2	CISCO 760	For connecting the internal network to the Numeris box
Box 3	Ethernet converter	For converting the signals adapted to Ethernet link
PC01	Personal Computer 01	Pentium 2, 400 Mhz, RAM 64 Mb, Hard Disk 4 Gb, CD reader, 1.44 Mb diskette writer, Colour screen 17 inches (1024 x 768 p) Windows 98 (2 nd edition), Office 2000 (Access, Excel, Word, PowerPoint), Visio4, AutoCAD LT 2002
PC02	Personal Computer 02	Pentium 2, 166 Mhz, RAM 64 Mb, Hard Disk 3 Gb, CD reader, 1.44 Mb diskette writer, Colour screen 17 inches (1024 x 768 p) Windows 98 (2 nd edition), Office 2000 (Excel, Word, PowerPoint), Adobe ImageReady 7.0, Adobe Photoshop 7.0
PC03	Personal Computer 03 dedicated for visible images treatments	Pentium 3, 933 Mhz, RAM 256 Mb, Hard Disk 40 Gb, CD R/RW writer, DVD-RW writer, 1.44 Mb diskette writer, Colour screen 17 inches (1024 x 768 p) Windows 2000 5/0, Office 2000 (Excel, Word, PowerPoint), ImageReady 7.0, Adobe Photoshop 7.0, Tecplot 9.0, Microsoft Visual Studio NET, VITEC Multimedia tools (Images digitiser, Vitec player, Toolbox)
PC04	Personal Computer 04	Presently, out of order

PC05	Personal Computer 05 dedicated to the National Instrument Data Logger	Pentium 3, 933 Mhz, RAM 256 Mb, Hard Disk 20 Gb, CD reader, 1.44 Mb diskette writer, Colour screen 17 inches (1024 x 768 p) Windows 98 (2 nd edition), Office 1997 (Access, Excel, Word, PowerPoint), National Instruments LabView 6.1, AutoCAD LT 2002
PC06	Laptop	Pentium, RAM, RAM 128 Mb, Hard Disk 4.5 Gb, CD reader, 1.44 Mb diskette writer, PCMCIA cards reader, Colour screen 11 inches Windows 98 (2 nd edition), Office 98 (Access, Excel, Word, PowerPoint), Visio3, Adobe Photoshop 7.0, Vitec player, ThermaCam Explorer 99, ThermaCam Researcher 2001,
PC07	Personal Computer 07 dedicated to infra red images acquisition	Pentium 3, 866 Mhz, RAM 256 Mb, Hard disk 40 Gb, mobile Hard disk 180, DVD reader, PCMCIA cards reader, 1.44 Mb diskette writer, Colour screen 17 inches (1024 x 768 p) Windows 2000, Office 2000 (Access, Excel, Word, PowerPoint), ThermaCam Explorer 99, ThermaCam Researcher 2001, Microsoft Visual Studio NET, ImageReady 7.0, Adobe Photoshop 7.0, Tecplot 9.0
PC08	Personal Computer 08	Athlon XP, 1 Ghz, RAM 512 Mb, Hard disk 40 Gb, DVD reader, External cards reader, 1.44 Mb diskette writer, Colour screen 17 inches (1024 x 768 p) Windows 2000, Office 2000 (Access, Excel, Word, PowerPoint), ImageReady 7.0, Adobe Photoshop 7.0
C11	Connection point 11	Not yet used, available for connecting any computers or laptops, including guests machines
C12	Connection point 12	Not yet used, available for connecting any computers or laptops, including guests machines
C13	Connection point 13	Not yet used, available for connecting any computers or laptops, including guests machines

9.2 CONNECTION WITH THE INRA MAIN SERVER

The network of Les Vignères is connected to a specific server of INRA centre dedicated to the connection with remote INRA laboratories.

The specificity of the telephone link does not allowed high-speed exchanges.

The Files Transfer Procedure installed on all the machines is efficient for transferring up to 100-Mb files to and from Les Vignères.

One of the machine is equipped with mobile hard disk in order to transfer the files provided by the infrared imager, larger than 1Gb.

The same connection permits to manage the e-mails exchanges using Eudora software, either internal to the Institute or external without any problems, except time limitation due to the specificity of the telephone line.

9.3 INTERNET CONNECTIONS

All the machines of Les Vignères network have their own IP address registered in and managed by the specific INRA's server.

All the machines use either Microsoft Explorer or Netscape navigators for connecting through Internet to Web sites.

There are no limitations, except those due to:

- the characteristics of the link, and
- the internal rules for connecting to Web sites.

Guest machines can be connected to the Les Vignères network.

They need only to be registered by the main server of Avignon Research Centre.