



HAL
open science

Badnaviruses and banana genomes: a long association sheds light on Musa phylogeny and origin

Matthieu Chabannes, Marc Gabriel, Abderrahmane Aksa, Serge Galzi, Jean-françois Dufayard, Marie-line Iskra-caruana, Emmanuelle Muller

► **To cite this version:**

Matthieu Chabannes, Marc Gabriel, Abderrahmane Aksa, Serge Galzi, Jean-françois Dufayard, et al.. Badnaviruses and banana genomes: a long association sheds light on Musa phylogeny and origin. *Molecular Plant Pathology*, 2021, 22 (2), pp.216-230. 10.1111/mpp.13019 . hal-03049799

HAL Id: hal-03049799

<https://hal.inrae.fr/hal-03049799>

Submitted on 10 Dec 2020



HAL is a multi-disciplinary open access archive for the deposit and dissemination of scientific research documents, whether they are published or not. The documents may come from teaching and research institutions in France or abroad, or from public or private research centers.

L'archive ouverte pluridisciplinaire **HAL**, est destinée au dépôt et à la diffusion de documents scientifiques de niveau recherche, publiés ou non, émanant des établissements d'enseignement et de recherche français ou étrangers, des laboratoires publics ou privés.



Distributed under a Creative Commons Attribution 4.0 International License

Badnaviruses and banana genomes: a long association sheds light on *Musa* phylogeny and origin

Matthieu Chabannes ¹ | Marc Gabriel¹ | Abderrahmane Aksa¹ | Serge Galzi¹ | Jean-François Dufayard² | Marie-Line Iskra-Caruana ¹ | Emmanuelle Muller ¹

¹CIRAD, UMR BGPI, University of Montpellier, Montpellier SupAgro, Montpellier, France

²CIRAD, UMR AGAP, University of Montpellier, CIRAD, INRA, Montpellier SupAgro, Montpellier, France

Correspondence

Emmanuelle Muller, CIRAD, UMR BGPI, University of Montpellier, Montpellier SupAgro, 34398 Montpellier, France.
Email: emmanuelle.muller@cirad.fr

Abstract

Badnaviruses are double-stranded DNA pararetroviruses of the family *Caulimoviridae*. Badnaviral sequences found in banana are distributed over three main clades of the genus *Badnavirus* and exhibit wide genetic diversity. Interestingly, the nuclear genome of many plants, including banana, is invaded by numerous badnaviral sequences although badnaviruses do not require an integration step to replicate, unlike animal retroviruses. Here, we confirm that banana streak viruses (BSVs) are restricted to clades 1 and 3. We also show that only BSVs from clade 3 encompassing East African viral species are not integrated into *Musa* genomes, unlike BSVs from clade 1. Finally, we demonstrate that sequences from clade 2 are definitively integrated into *Musa* genomes with no evidence of episomal counterparts; all are phylogenetically distant from BSVs known to date. Using different molecular approaches, we dissected the coevolution between badnaviral sequences of clade 2 and banana by comparing badnavirus integration patterns across a banana sampling representing major *Musa* speciation events. Our data suggest that primary viral integrations occurred millions of years ago in banana genomes under different possible scenarios. Endogenous badnaviral sequences can be used as powerful markers to better characterize the *Musa* phylogeny, narrowing down the likely geographical origin of the *Musa* ancestor.

KEYWORDS

Badnavirus, banana streak virus, endogenous pararetrovirus, host and virus coevolution, *Musa* phylogeny

1 | INTRODUCTION

Although integration is not a requisite in the life cycle of pararetroviruses, integrated pararetrovirus sequences do occur in the nuclear genomes of several plant species, including banana (Harper et al., 1999; Lockhart & Jones, 2000; Ndwora et al., 1999), citrus (Yu et al., 2019), dahlia (Pahalawatta et al., 2008), fig (Laney et al.,

2012), grape (Bertsch et al., 2009), petunia (Richert-Poggeler et al., 2003), pineapple (Gambley et al., 2008), potato (Hansen et al., 2005), rice (Kunii et al., 2004), tobacco, and tomato (Gregor et al., 2004; Jakowitsch et al., 1999; Staginnus et al., 2007). Integration into host chromosomes probably occurs in the nucleus (Hull, 2002) via non-homologous end-joining (NHEJ) during repair of host DNA breaks, as reported for several endogenous viral elements (EVEs) (Feschotte

This is an open access article under the terms of the Creative Commons Attribution License, which permits use, distribution and reproduction in any medium, provided the original work is properly cited.

© 2020 The Authors. *Molecular Plant Pathology* published by British Society for Plant Pathology and John Wiley & Sons Ltd

& Gilbert, 2012; Holmes, 2011). These integrated sequences are relics of quite ancient infection events, so their presence is not necessarily associated with current infection, especially when present only as partial viral sequences or nonfunctional sequences with null mutations.

Usually, pararetroviral integrations have no deleterious impact on their host plants because they are untranslatable sequences. However, in some cases, integrated sequences contain a functional full-length viral genome that can be activated, leading to systemic infection of the host plant. Also known as infective integration, examples include *Petunia vein clearing virus* (genus *Petuvirus*) in petunia (Richert-Poggeler & Shepherd, 1997), *Tobacco vein clearing virus* (genus *Solendovirus*) in tobacco (Gregor et al., 2004), and banana streak viruses (BSVs; genus *Badnavirus*) in banana (Gayral et al., 2008; Harper et al., 1999; Ndowora et al., 1999). BSVs in banana are by far the most economically significant examples; indeed, banana—one of the oldest domesticated crops in the world—is ranked as the world's sixth most important food crop in terms of gross production value after cassava, potato, rice, wheat, and maize (FAOStat, 2014), and first among fruit crops.

Most modern banana cultivars arose via traditional selection processes (Perrier et al., 2011). The seedy progenitors of all domesticated banana cultivars are *Musa acuminata* (A genome) and *Musa balbisiana* (B genome) and, to a much lesser extent, *Musa schizocarpa* (S genome) and *Musa textilis/Musa maclayi* (T genome) (Carreel et al.,

2002; Daniells et al., 2001a). *M. acuminata* exhibits large diversity based on morphological and molecular characters, and up to nine different subspecies are known (Christelova et al., 2011; Daniells et al., 2001a). *M. balbisiana* shows comparatively narrower diversity, with a more restricted centre of origin (Perrier et al., 2011). Interestingly, infective endogenous BSV sequences (eBSV)—found exclusively in the *M. balbisiana* B genome to date—belong to three distinct BSV species: *Banana streak GF virus*, *Banana streak IM virus*, and *Banana streak OL virus* (Chabannes et al., 2013; Gayral et al., 2008; Iskra-Caruana et al., 2010). Several reports have noted the presence of partial badnaviral sequences also in *M. acuminata* and/or *M. balbisiana* genomes (Geering et al., 2001; Ndowora et al., 1999), but most significant was the description of 33 distinct groups of banana endogenous viruses (BEV) related to either *M. acuminata* or *M. balbisiana* genomes (Geering et al., 2005).

The genomes of badnaviruses contain three main open reading frames (ORFs), with the largest encoding a movement protein, a capsid protein, an aspartic protease, a reverse transcriptase (RTase), and a ribonuclease H (RNase H). Badnavirus genetic diversity (based on partial sequences of the RTase and RNase H genes) in banana appears large and complex, as viral sequences generated to date are distributed over three different clades within the diversity of the genus *Badnavirus* (Gayral & Iskra-Caruana, 2009; Harper et al., 2005) (Figure 1). Importantly, the 11 full-length sequenced episomal BSV species responsible for banana streak disease described to date

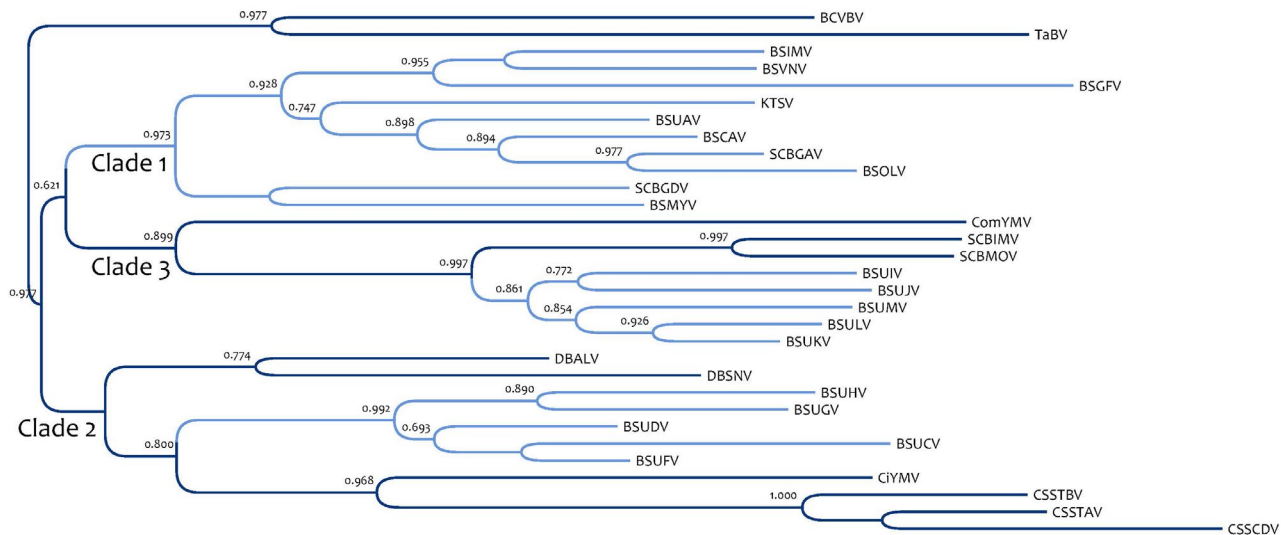

FIGURE 1 Maximum-likelihood phylogeny based on RTase/RNase H region. Statistical aLRT SH-like branch supports given above nodes when >0.6 . Virus or sequences names (GenBank numbers): BSUCV (AJ968464), BSUDV (AJ968465), BSUFV (AJ968469), BSUGV (AJ968470), BSUHV (AJ968472), Banana streak Cavendish virus (BSCAV, HQ593111), *Banana streak MY virus* (BSMYV, AY805074), *Banana streak GF virus* (BSGFV, AY493509), *Banana streak IM virus* (BSIMV, HQ659760), *Banana streak OL virus* (BSOLV, AJ002234), *Banana streak VN virus* (BSVNV, AY750155), *Banana streak UA virus* (BSUAV, HQ593107), *Banana streak UI virus* (BSUIV, HQ593108), *Banana streak UJ virus* (BSUJV, AJ968501), *Banana streak UK virus* (BSUKV, AJ968504), *Banana streak UL virus* (BSULV, HQ593109), *Banana streak UM virus* (BSUMV, HQ593110), *Bougainvillea chlorotic vein banding virus* (BCVBV, EU034539), *Cacao swollen shoot Togo B virus* (CSSTBV, L14546), *Cacao swollen shoot CD virus* (CSSCDV, JN606110), *Cacao swollen shoot Togo A virus* (CSSTAV, AJ781003), *Citrus yellow mosaic virus* (CiYMV, AF347695), *Commelina yellow mottle virus* (ComYMV, X52938), *Dioscorea bacilliform AL virus* (DBALV, X94576-581), *Dioscorea bacilliform SN virus* (DBSNV, DQ822073), *Kalanchoe top-spotting virus* (KTSV, AY180137), *Sugarcane bacilliform IM virus* (SCBIMV, AJ277091), *Sugarcane bacilliform MO virus* (SCBMOV, M89923), *Sugarcane bacilliform Guadeloupe A virus* (SCBGAV, FJ824813), *Sugarcane bacilliform Guadeloupe D virus* (SCBGDV, FJ439817), *Taro bacilliform virus* (TaBV, AF357836)

TABLE 1 PCR primers used to detect badnaviral species of the different clades in banana plants

Specificity	Forward primer (5'–3')	Reverse primer (5'–3')	Tm (°C)	Number of PCR cycles	Amplicon size (bp)
IC-PCR for species of clade 1					
BSOLV	ATCTGAAGGTGTGTTGATCAATGC	GCTCACTCCGCATCTTATCAGTC	62	30	522
BSGFV	ACGAACTATCAGACTTGTTC AAGC	TCGGTGG AATAGTCTGAGTCTTC	62	30	475
BSIMV	TGCCAACGAATACTACATCAAC	CACCCAGACTTTTCTTTCTAGC	62	25	383
BSMYV	TAAAAGCACAGCTCAGAACAACC	CTCCGTGATTCTTCGTGGTC	62	30	588
PCR for species of clade 2					
BEV UC	CTGAAGAATGCACCAGCAATATTC	TCCATACATCCGTCAGTTTCGAG	60	35	542
BEV UD	GGTACAGAACAATTYATTGCTGTGTAC	CCAGTTGGGCTTGT TTTTGAATAC	60	35	362
BEV UF	ACTGCTTCAAAGGTACGGAACAAT	CTAGATCCGGGAGATTTGTACCA	60	35	450
BEV UG	TGGACGACTGCTTTCGAGGT	CATACATCCGTCCACCTTAGGA	60	35	506
BEV UH	GCATCTTCATAAAATGCTAGAAATCTGT	TCTGGGGGTGGTACTTCTAGATCA	60	35	381
BEV NGA	CCGTGTTCCAAAGGAAAATGGAC	CATGCATCCGTCTGTTTCAAGTATTATG	60	35	524
BEV P	CAAAGGTACAGAACAATTTATAGCAGTC	GGAGTAAAGTGGTCTAACAGCCTT	60	35	348
BEV Q	CCTGGTATTCTCAGAGAATGAAGAA	GTCTTCGGGGGGA ACTTCTAAG	60	35	418
PCR for species of clade 3					
BSUIV	AAGAAGARCATGCGGAGCATT	GCATCCTCTGGGGGTATTGC	55	35	401
BSUJV	CAGAAGCCTTTATAGCAGTTTACATT	TCCTGCTTCATCCTTCTGATAATT	55	35	412
BSUKV	GATGATATTCTGGTTTTTTCAGAACTA	CAGTTTCAATTACTATGTATGCATCTGA	55	35	448
BSULV	TGGTTTTCTCAGAACTGARGAAGA	ATGTATGCATCTTGAGGGGTAT	53	35	424
BSUMV	AGGGACTGAGGCATTATAGC	TTCATYCTTCTGATTATCTTCCA	50	35	412

belong only to clades 1 and 3; clade 3 encompasses East African BSV species exclusively (Geering et al., 2005, 2011; Harper & Hull, 1998; James et al., 2011). All other (partial) badnavirus sequences described in banana are in clade 2. However, controversially, Harper et al. (2005) associated banana streak disease in Uganda (banana genotype East African Highland [EAH] AAA) with badnaviral sequences belonging to clade 2. With the previous International Committee on Taxonomy of Viruses (ICTV) demarcation criteria of an 85% nucleotide divergence threshold (now fixed at 80%), they proposed five novel BSV Uganda BSUXV species (X = species descriptor): BSUCV, BSUDV, BSUFV, BSUGV, and BSUHV. Subsequently, examining different evolutionary parameters of episomal and endogenous sequences, Gayral and Iskra-Caruana (2009) suggested that BSV sequences from clade 2, including the five BSUXV species, exist as endogenous sequences only, unlike BSV sequences from clade 3, which are episomal.

Here, we focused our research on banana badnaviral clade 2 sequences to categorize their exact nature (integrated and/or episomal) and estimate their distribution in the family Musaceae. Performing Southern blot and immunocapture PCR (IC-PCR) tests on a wide sample survey of 109 samples of EAH AAA banana collected in Uganda, we extended sampling to include diploid banana plants representative of the diversity of the family Musaceae. Interestingly, the different BEV integration patterns observed indicate that banana genomes have been colonized extensively over time under different possible scenarios. BEVs could thus serve as phylogenetic markers to precisely map *Musa* phylogeny. This coevolution between

clade 2 badnaviral sequences and banana allows us to better estimate the age of different integration events and narrow the likely geographical origin of the *Musa* ancestor.

2 | RESULTS

2.1 | Detection of BSV sequences in Ugandan EAH AAA banana samples

We estimated the distribution and prevalence of BSV species in 109 samples representative of local banana diversity collected from EAH AAA bananas in Uganda. All samples were first subjected to DNase I-treated IC-PCR using specific primers (Table 1) to detect episomal forms of the main circulating BSVs, banana streak OL virus (BSOLV), banana streak GF virus (BSGFV), banana streak IM virus (BSIMV), and banana streak MY virus (BSMYV), belonging to species of clade 1. Among 91 EAH AAA plant samples exhibiting typical disease symptoms, only 34 (c.1:3) were infected by the BSVs from clade 1 tested here: 32 plants by BSOLV and two by BSIMV (Table 2). Symptomless plants were also infected, one by BSOLV and four by BSIMV. In total, 33/109 plants were infected with BSOLV and six with BSIMV, with only one plant coinfecting with both viruses. No samples were infected with either BSMYV or BSGFV.

Because the polyclonal antiserum used for IC-PCR did not reliably detect BSVs from clade 3, every sample was subjected to direct PCR using specific primers (Table 1) to detect banana streak

TABLE 2 Badnavirus diversity in EAH AAA banana samples from Uganda

Banana samples	Clade 1				Clade 2 BSUCV, BSUDV, BSUFV, BSUGV, BSUHV	Clade 3				
	BSOLV	BSIMV	BSMYV	BSGFV		BSUIV	BSUJV	BSUKL	BSULV	BSUMV
With typical BSV symptoms (91)	32	2	0	0	91	20	2	0	34	34
Symptomless or doubtful symptoms (18)	1	4	0	0	18	2	0	0	0	0

Note. Numbers refer to the number of plants.

EAH AAA banana genetic diversity encompasses the five following clone sets: Nakitembe, Musakala, Nakabulu, Nfuuka, and Nbide (beer cultivar).

UI virus (BSUIV), banana streak UJ virus (BSUJV), banana streak UK virus (BSUKV), banana streak UM virus (BSUMV), and banana streak UL virus (BSULV). Of 91 plants with symptoms, 82 appeared infected by at least one of the five BSVs tested from clade 3. No samples were infected by BSUKV. Of the four other BSVs in this clade, BSUJV is strongly under-represented in our samples, with only two plants harbouring BSUJV sequences compared to 20, 34, and 34 for BSUIV, BSUMV, and BSULV, respectively (Table 2). Two symptomless banana plants were infected with BSVs from clade 3, both carrying BSUIV. The finding that BSVs from clade 3 are detected in most plants with symptoms, and absent from most symptomless EAH AAA plants, supports the episomal nature of viruses in these five BSV species.

Similarly, direct PCR using specific primers identified BSV sequences from clade 2. All samples, regardless of symptoms, contained all five BSV sequences belonging to clade 2 (Table 2). Their systematic presence in every EAH AAA banana tested suggests that sequences from all five species are probably integrated into the *M. acuminata* genome.

2.2 | Are badnaviral sequences from clades 2 and 3 integrated in Ugandan EAH AAA genotypes?

To establish whether badnavirus sequences corresponding to species from clades 2 and 3 are episomal, integrated or both, Southern blot analyses were performed. Probes corresponding to BSUDV and BSUFV (clade 2), and BSUIV, BSULV, and BSUMV (clade 3) were hybridized to undigested and digested genomic DNA of three banana samples with symptoms and three samples without symptoms (Figures 2, S1, and S2) representative of the whole EAH AAA diversity. Figure 2 illustrates results obtained with BSUDV and BSUMV probes. The three samples with symptoms were negative for BSVs from clade 1, one was infected with BSUIV (sample 5), another with BSUMV (sample 7), and the third was coinfecting with BSULV and BSUIV (sample 8). As expected, hybridization with the BSUMV probe (Figure 2a) yielded a signal only with sample 7, testing positive with BSUMV primers. The upper band corresponds either to viral

concatemers, as described by Geijskes et al. (2004), or, more probably, to episomal viral DNA present in the heavy plant genomic DNA, with the two lower bands corresponding to open circular and supercoiled viral double-stranded (ds)DNA (the lowest band). The viral sequence (which was not available when the experiments were carried out) does not harbour a recognition sequence for either *KpnI* or *Alw441*; the hybridization pattern was, therefore, similar to that of undigested DNA (Figure 2a). Similar patterns were observed with BSUIV and BSULV probes in samples testing positive with the corresponding primers (Figures S1 and S2). Thus, the three BSV species belonging to clade 3 do not seem to be integrated in the samples tested, representing the five clone sets of the EAH AAA genotypes, or in Cavendish (AAA), Pahang (AA), and PKW (BB) control plants. Additionally, rolling circle amplification (RCA) performed on one BSUIV and two BSUMV infected banana samples gave products of high molecular weight in all cases. RCA products were digested and the sum of the fragments obtained was in each case of the order of 7.5 kb (Figure 3). For one of the samples, the fragments were cloned and sequenced, confirming the presence of BSUMV (data not shown).

In contrast, and corroborating PCR results, the BSUDV probe hybridized with all (digested and undigested) *M. acuminata* samples tested, including virus-free banana plants cultivars Cavendish AAA and Pahang AA (Figure 2b). We also observed high molecular weight signals on undigested DNA (>15 kb) without the two lower bands (open circular/supercoiled viral dsDNA, cf. Figure 2a) associated with multiple band patterns; the cumulative size of all bands was >7 kb per sample on digested DNA. This result indicates that BSUDV is integrated into the genomes of all genotypes tested except PKW. Similar patterns were observed with a BSUFV probe (Figure S1). We also performed a parallel immunosorbent electron microscopy experiment on eight symptomless banana samples containing only clade 2 sequences (also analysed in the Southern blot experiment) and on nine samples with symptoms containing clade 3 and clade 2 sequences (including samples 7 and 8 in Figure 2, and sample 9 in Figure S1). As expected, viral particles were observed only for the samples with symptoms containing clade 3 sequences (Figure S3).

Consequently, and given the absence of corresponding episomal virus in the samples tested so far and identity with any known

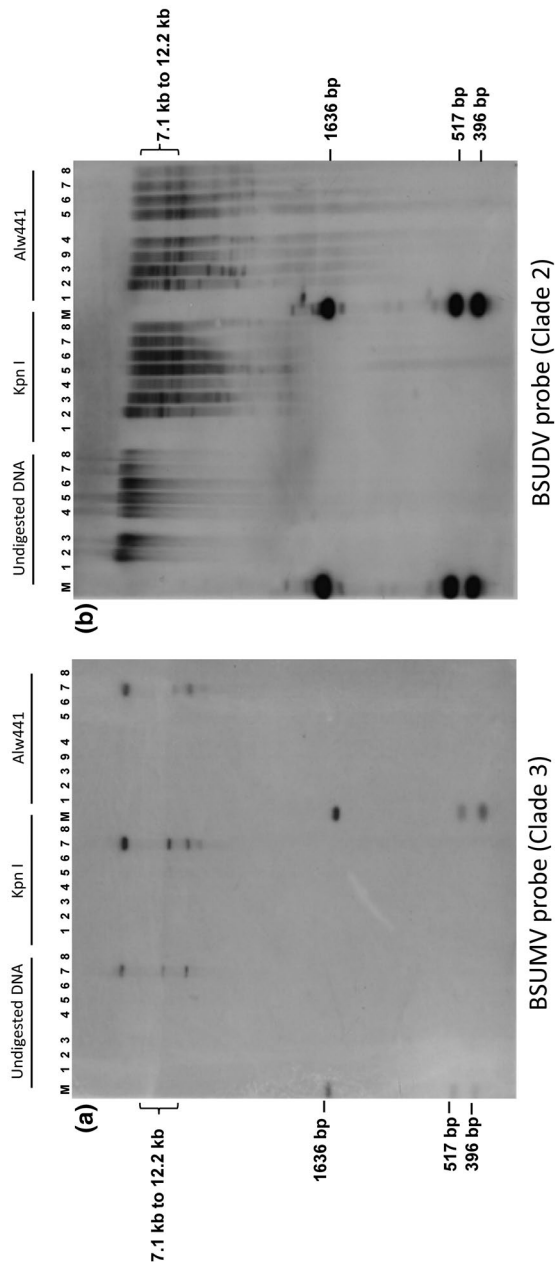

FIGURE 2 Southern blot hybridization of genomic DNA from EAH AAA banana plants using clade 3 (BSUMV; a) and clade 2 (BSUDV; b) badnaviral sequences as probes. Total genomic DNA (undigested, *KpnI*-digested, *Alw441*-digested): 1, Pisang Klutuk Wulung (PKW) (BB genotype); 2, Cavendish (CAV) (AAA genotype); 3, Pahang (AA genotype); 4–9, EAH AAA plants (4, 6, 9, healthy samples [symptomless and no bacilliform particles]; 5, BSUIV-infected; 7, BSUMV-infected; 8, BSUIV and BSULV coinfecting). M, 1 kb ladder from Invitrogen

viral species far below the threshold of 80%, we definitively conclude that clade 2 BSUDV and BSUFV in our tested banana samples are exclusively endogenous badnaviral-related sequences. According to the PCR results (Table 2), we can extend this statement to other clade 2 species and reclassify these BSUXV species under the general term BEV UX, as defined by Geering et al. (2005).

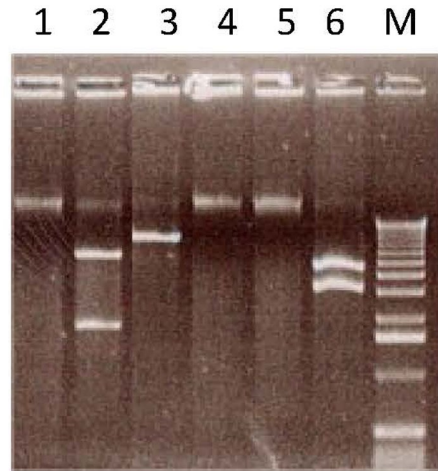

FIGURE 3 Agarose gel analysis of rolling circle-amplified (RCA) DNA. Undigested (lanes 1, 4, and 5), *KpnI*-digested (lane 2), *BamHI*-digested (lane 3), and *PstI*-digested (lane 6) RCA products derived from BSUIV (lanes 1 and 2) and BSUMV (lanes 3, 4, 5, and 6) infected banana plants. M, 1 kb ladder from Invitrogen

2.3 | Are clade 2 badnaviral sequences present in the *Musa* diversity?

To gain a better overview of the presence/spread of clade 2 badnaviral sequences in banana genomes over evolutionary time, we looked for clade 2 BEVs in diploid banana plants representing subspecies of *M. acuminata* and *M. balbisiana*, as well as other species from the genus *Musa* and the two other genera of Musaceae (*Ensete* and *Musella*).

We first analysed diversity of clade 2 badnaviral sequences using PCR primers specific for different clade 2 BEVs (Table 1). BEV-NGA corresponds to a distinct BEV integrated in the genome of *M. acuminata* subsp. *malaccensis* 'Pahang' (D'Hont et al., 2012). BEVs UC and UF generated amplification products from all *M. acuminata* samples (AA1–AA14 and AA26) and all *M. balbisiana* samples (BB15–BB20) (Table 3). BEV UG primers gave the same results, with the exception of four *M. acuminata* samples (AA4, AA5, AA14, and AA26), where no amplification was obtained. Primers specific to BEVs UD, UH, and NGA amplified products from all *M. acuminata* samples. In contrast, no amplification was obtained for the five *M. balbisiana* samples. Other species of the family Musaceae yielded very diverse results. Interestingly, *M. laterita* (M22) contained all six BEVs tested, *M. ornata* (M25) five BEVs (only BEV UD missing), *M. basjoo* (M24) and *M. itinerans* (M27) harboured both BEV UC and BEV UG, and BEV UH was detected in *M. schizocarpa* (M21) (Table 3). Furthermore, no BEVs from clade 2 were amplified in *M. textilis* (M23) and *M. coccinea* (M28), or from samples of the other two Musaceae genera (M32 and M34) (Table 3).

All PCR product sequences were aligned to generate a phylogenetic tree (Figure 4). Our analysis included BEVs that are closely related to our sequences from among the different subgroups defined by Geering et al. (2005). As expected, all amplified sequences belong to clade 2 and most sequences grouped with the reference sequence of the amplified BEVs. Notably, all BEVs identified here can be assigned

TABLE 3 PCR amplification results

Species	Plant samples	BEV-specific primers							
		BEV UC	BEV UD	BEV UF	BEV UG	BEV UH	BEV NGA	BEV P	BEV Q
<i>M. acuminata</i>	AA1/errans	+	+	+	+	+	+	-	-
	AA2/zebrina	+	+	+	+	+	+	-	-
	AA3/siamea	+	+	+	+	+	+	-	-
	AA4/malaccensis	+	+	+	-	+	+	-	-
	AA5/malaccensis	+	+	+	-	+	+	-	-
	AA6/truncata	+	+	+	+	+	+	-	-
	AA7/burmannica	+	+	+	+	+	+	-	-
	AA8/microcarpa	+	+	+	+	+	+	-	-
	AA9/malaccensis (ITC0250)	+	+	+	+	+	+	-	-
	AA10/banksii	+	+	+	+	+	+	-	-
	AA11/siamea	+	+	+	+	+	+	-	-
	AA12/malaccensis (ITC0399)	+	+	+	+	+	+	-	-
	AA13/burmannicoides	+	+	+	+	+	+	-	-
	AA14/siamea	+	+	+	-	+	+	-	-
AA26/banksii	+	+	+	-	+	+	-	-	
<i>M. balbisiana</i>	BB15/Honduras	+	-	+	+	-	-	+	+
	BB16/Cameroun	+	-	+	+	-	-	+	+
	BB17/Pisang Klutuk Wulung	+	-	+	+	-	-	+	+
	BB18/Butuhan	+	-	+	+	-	-	+	+
	BB19/Lal Velchi	+	-	+	+	-	-	+	+
	BB20/Papouasie Nouvelle Guinée	+	-	+	+	-	-	+	+
Other species of the family Musaceae	M21/ <i>M. schizocarpa</i>	-	-	-	-	+	-	-	-
	M22/ <i>M. laterita</i>	+	+	+	+	+	+	-	-
	M23/ <i>M. textilis</i>	-	-	-	-	-	-	-	-
	M24/ <i>M. basjoo</i>	+	-	-	+	-	-	-	-
	M25/ <i>M. ornata</i>	+	-	+	+	+/-	+	-	-
	M27/ <i>M. itinerans</i>	+	-	-	+	-	-	-	-
	M28/ <i>M. coccinea</i>	-	-	-	-	-	-	-	-
	M32/ <i>Ensete ventricosum</i>	-	-	-	-	-	-	-	-
	M34/ <i>Musella lasiocarpa</i>	-	-	-	-	-	-	-	-

Note. AA diploid *M. acuminata* bananas, BB diploid *M. balbisiana* bananas, and other species from the family Musaceae.

to a BEV subgroup described by Geering et al. (2005) (Figure 4) and exhibit >85% nucleotide sequence similarity with other sequences from the same subgroup. BEV UD is close to BEV5 with 92.7%–98.8% nucleic acid identity, BEV UH to BEV13 (94.3%–97.4% identity), BEV NGA to BEV2 (96.3%–98.3% identity), and BEV F to BEV1 (86.2%–98.8% identity). Sequences amplified by BEV UC primers were divided into two subgroups: one resembles BEV9 (90.4%–98.5% identity) and the other BEV8 (samples M24C and M27C, 89% identity). Similarly, sequences amplified by BEV UG primers are related to BEV11 (97.4%–98.8% identity) in sequences originating from *M. balbisiana* and to

BEV12 (95.7%–99.1% identity) in all other sequences. Interestingly, two new sequence groups were revealed due to weak specificity of the first BEV UD and UF primer sets designed; named P and Q, respectively, both are related to known BEVs, that is, BEV25 for BEV P (93%–95.5% identity) and BEV14 for BEV Q (92% identity). New BEV P- and Q-specific primers were then used to rescreen all samples. Interestingly, only *M. balbisiana* samples harbour BEVs P and Q (Table 3). As observed in the phylogenetic tree (Figure 4), BEV UF is divided into two subgroups; one is more closely linked to BEV UD (nucleotide identity c.85%), which could be derived from BEV UF.

FIGURE 4 Maximum-likelihood phylogeny of clade 2 badnavirus sequences based on RTase/RNase H region. Statistical aLRT SH-like branch supports given above nodes when >0.6. BEV sequences (Geering et al., 2005) close to our BEV groups are included. BSV species from clades 1 and 3 are used as outgroups. AA1–M27 refer to sample number. Samples: blue, AA; red, BB; green, M. Sequences used for comparative analysis (GenBank numbers): BEV1-PWi11 (AY028702), BEV1-Bank10 (AY189385), BEV2-Bank19 (AY189390), BEV5-Mal3 (AY189398), BEV8-Mal15 (AY189395), BEV9-Batu20 (AY189422), BEV11-PKW8 (AY189442), BEV12-OBLE3 (AY189412), BEV13-Shiz2 (AY189378), BEV14-PKW12 (AY189436), BEV25-Batu10 (AY189420), BEV-NGA integrated in *Musa acuminata* subsp. *malaccensis* 'Pahang' (from genomic scaffold 305, HE806766)

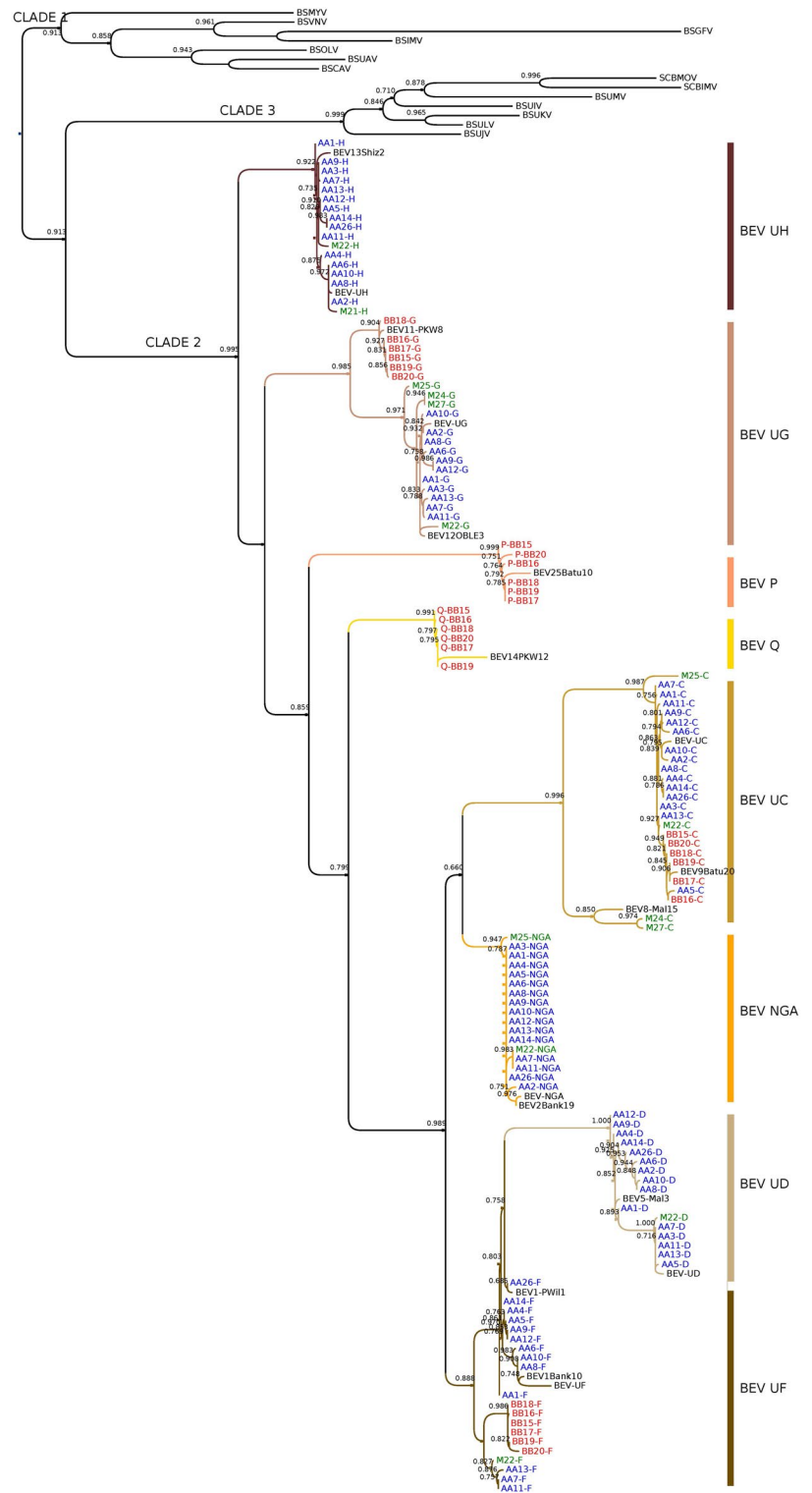

2.4 | Clade 2 badnaviral sequences are spread widely in the *Musa* diversity

To further characterize BEVs in the *Musa* diversity, we hybridized banana genomic DNA of the same samples with probes corresponding to individual BEVs (Figure 5). Genomic DNA was digested by *HindIII*, which does not cleave BEVs UC, UD, UF, NGA, and P probe sequences but recognizes a single conserved site in

BEVs UG, UH, and Q. No signal was observed for samples corresponding to other genera of the family Musaceae (M32 and M34) (data not shown).

Importantly, no bands corresponding to episomal viruses were observed in any of the samples. Overall, Southern blot hybridizations and PCR results were very consistent, although a few samples generated hybridization signals while the corresponding PCR was negative (e.g., samples AA4, AA5, AA14 plus AA26 with the BEV UG probe). A

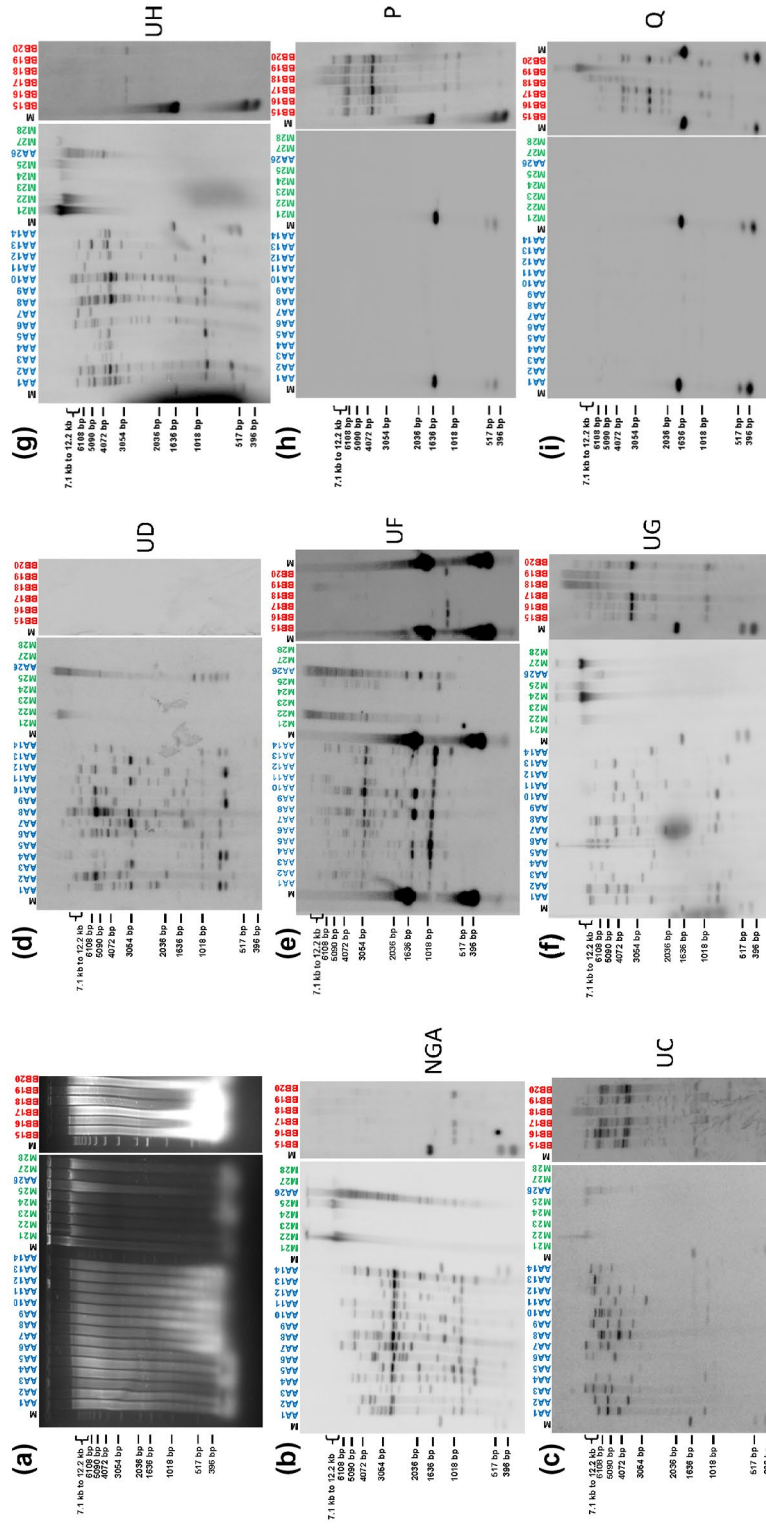

FIGURE 5 Southern blot hybridization of total genomic DNA (digested by *Hind*III) from plants of the family Musaceae using diverse clade 2 badnaviral sequences as probes. Samples AA1–14 and AA26 correspond to *M. acuminata* genotypes, samples M21–25, M27, and M28 to other species from the family Musaceae. (a) Agarose gel electrophoresis. (b)–(i) Hybridization results for BEV probes UC (b), UD (c), UH (f), UG (g), P (h), and Q (i). M, 1 kb ladder from Invitrogen

mismatch at the primer recognition site seems the most likely explanation. In addition, although membranes were washed stringently, we cannot rule out slight cross-hybridization yielding a very weak signal, as explained further below. The BEV NGA probe hybridized with all *M. acuminata* samples, showing several bands ranging from high to low molecular weight, revealing several BEV NGA sequences in those samples. Although individuals displayed different patterns, they all shared two conserved fragments at 1 kb and c.3 kb (Figure 5b). In four *M. balbisiana* samples (BB15–BB17 and BB20), a similarly weak signal was seen at c.1 kb. This signal is probably due to cross-hybridization with BEV UF because no PCR amplification was obtained with BEV NGA primers on *M. balbisiana* samples, hybridization patterns were similar to those of BEV UF but fainter, and BEV UF shares c.85% identity with BEV NGA. Geering et al. (2005) also observed the absence of BEV 2 (similar to BEV NGA) in *M. balbisiana*. We also observed hybridization signals corresponding to high molecular weight (>12 kb) bands in samples of other species of the genus *Musa* (M22, M24, M25, and M27). Similar to the NGA probe, we observed hybridization signals both for *M. acuminata* and *M. balbisiana* with BEV UC, UF, UG, and UH probes (Figure 5c,e–g). Hybridization patterns differed for all *M. acuminata* samples for each given probe and between probes, whereas hybridization patterns in *M. balbisiana* plants were much more conserved, with fewer integrations detected except for BEV UC, for which polymorphic patterns were observed (Figure 5c). Again, hybridization signals corresponding to high molecular weight (>12 kb) bands were present in some species other than *M. acuminata* and *M. balbisiana* belonging to the genus *Musa*. Finally, corroborating PCR amplification results, the three remaining probes (BEV-UD, -P, and -Q) exhibited very striking pattern differences between *M. acuminata* and *M. balbisiana* samples, with BEV UD hybridizing only with *M. acuminata* individuals (Figure 5d), and BEV P (Figure 5h) and Q (Figure 5i) probes hybridizing only with *M. balbisiana* samples.

3 | DISCUSSION

3.1 | Badnaviral sequences from clade 2 are integrated in the banana genome

Previous studies differed on whether BEV UC, UD, UF, UG, and UH species corresponded to integrated and/or episomal viruses (Gayral & Iskra-Caruana, 2009; Harper et al., 2005). To address this question, we performed DNA analysis on EAH AAA triploids collected in BSV-affected areas in Uganda as well as on a diverse sampling encompassing BSV-free diploids *M. acuminata* and *M. balbisiana* and other *Musa* species from the family Musaceae.

Our data revealed BEV integration in *M. acuminata* and *M. balbisiana* genomes, with hybridization signals observed for plants with symptoms (EAH AAA samples) and without symptoms (EAH AAA samples plus all the *Musa* diversity), consistent with the conclusion that BEV sequences are integrated in all our samples. For the first time, we show that some BEV sequences are shared between *M. acuminata* and *M. balbisiana* genomes.

Our Southern blot results (Figure 5) indicate the level of plant genome colonization, and suggest coevolution between virus and banana. All *M. acuminata* banana samples showed different integration patterns, suggesting a large degree of badnavirus sequence colonization via either multiple integration waves or genome duplications and evolution of one or a few initial integration events. Interestingly, each given probe suggested a wide polymorphism of badnavirus sequence integration in all *M. acuminata* banana samples, probably reflecting genetic and geographical *M. acuminata* subspecies diversity linked to various environmental pressures (Perrier et al., 2011). Our data are consistent with preliminary analysis by D'Hont et al. (2012), who reported the presence of different BEVs belonging to clade 2 at several loci distributed on 10/11 chromosomes of the genome of *M. acuminata* 'Pahang'.

The patterns observed for *M. balbisiana* are less complex, suggesting either fewer integrations or very few genome duplication events with a much less diverse profile. This low polymorphism of badnavirus sequence integration could be due to limited genetic diversity among *M. balbisiana* banana species (Carreel, 1994; Gayral et al., 2010). Overall, our data corroborate preliminary data published by Geering et al. (2001), who reported integrations in all samples, but fewer in *M. balbisiana* than in *M. acuminata*. Importantly, we demonstrate here for the first time that several BEVs are integrated in other species of the genus *Musa*, that is, *M. basjoo*, *M. itinerans*, *M. laterita*, *M. ornata*, and *M. schizocarpa*, (sections *Eumusa* or *Rhodochlamys*), but not in more phylogenetically distant samples corresponding to *Callimusa* and *Australimusa* sections or other genera of the family Musaceae (Table 3 and data not shown). This suggests that, for some BEVs, initial integrations occurred after formation of the family Musaceae but before speciation of the genus *Musa* (see below).

BEVs UC and UG appear to be widely disseminated within *M. acuminata* and *M. balbisiana*, unlike BEV UF, which is abundant in *M. acuminata* but poorly represented in *M. balbisiana*. Our results also show the absence of BEVs UD, UH, and NGA in *M. balbisiana* genomes, the absence of BEVs P and Q in *M. acuminata* genomes and the presence of all BEVs (except P and Q) in some other species of the family Musaceae.

Thus, our results differ from those of Harper et al. (2005), who suggested that BEVs UC, UD, UF, UG, and UH exist as episomal BSV particles, and support the hypothesis proposed by Gayral and Iskra-Caruana (2009), ascribing an exclusively integrated status to all BEVs of clade 2. Our present results allow us to ascribe the diversity of BSV exclusively to clades 1 (seven species to date: BSOLV, BSGFV, BSMYV, BSIMV, BSCAV, BSUAV, and BSVNV) and 3 (five species to date: BSUIV, BSULV, BSUMV, BSUJV, and BSUKV).

3.2 | What can BEVs tell us about the badnavirus/banana coevolution?

Badnaviral sequences linked to banana plants are distributed over three main clades (Figure 4). Surprisingly, they are as diverse as all

the other viruses of the genus *Badnavirus* with which they share a same common ancestor. Interestingly, the clade to which these sequences belong is associated with a particular status (episomal and/or integrated) as a result of specific interactions between the virus and its banana host.

Clade 1 encompasses BSVs that are either episomal *sensu stricto* or both episomal and integrated (Iskra-Caruana et al., 2014) as observed for BSOLV, BSGFV, BSIMV, and BSMYV, where integrations restricted to *M. balbisiana* genomes occurred only after speciation of *M. acuminata*/*M. balbisiana*, but before diversification of *M. balbisiana* (Chabannes et al., 2013). Although those eBSV exhibit a strong rearranged structure, with inverted and duplicated sequences at-testing to past integration, pseudogenization has not progressed to the point where they can no longer reconstitute an infectious viral genome (Chabannes et al., 2013; Chabannes & Iskra-Caruana, 2013; Iskra-Caruana et al., 2010). Because nucleic acid identity between a given eBSV and the corresponding BSV is >99%, it is likely that episomal BSOLV, BSGFV, and BSIMV observed now are due mainly, or exclusively, to the awakening of an endogenous counterpart (Chabannes et al., 2013; Gayral et al., 2008).

Because no episomal virus belonging to clade 2 has ever been detected in banana plants, we assume that the episomal BEV counterpart has long since disappeared. BEVs are thus relics of ancestor viruses that existed previously in wild plant populations, before speciation of the genus *Musa* and long before domestication and trade. Consequently, they are older than the BSVs and eBSV of clade 1, that is, the BSOLV, BSMYV, BSIMV, and BSGFV integrated in *M. balbisiana* genomes, with integration estimated to have occurred c.640,000 years ago (Gayral et al., 2010). Whether integrated BEV sequences confer a selective advantage by contributing towards plant virus resistance (via transcriptional or posttranscriptional gene silencing) is still an open question, but would explain both the disappearance of the counterpart episomal viruses and current integrated sequences resulting from pseudogenization. As described for other viruses (Feschotte & Gilbert, 2012), BEVs have become part of the genetic material of the banana host.

BSVs of clade 3 result from recent viral evolution in East Africa. Karamura et al. (1996) described a widespread BSV epidemic in Uganda on the East African Highland *M. acuminata* banana group (EAH AAA) (Kubiriba et al., 1997). The endemic presence of BSV in Uganda is probably the result of vegetative propagation of infected plants rather than vector transmission because cultivated cultivars are seedless and the rate of disease spread by mealybugs is slow (Daniells et al., 2001b; Kubiriba et al., 2001). Furthermore, BSVs generally do not have a severe impact on bunch production, particularly when cultural conditions are good. In the 109 EAH AAA samples analysed here, we observed a prevalence of species BSUIV, BSULV, and BSUMV from clade 3 (Table 2), whereas species BSUJV and BSUKV are poorly represented or absent, respectively, in agreement with the findings of Harper et al. (2005) (after correction of BSV species names mislabelled in the latter article; the species BSUHV, BSUIV, BSUJV, BSUKV, and BSULV described by

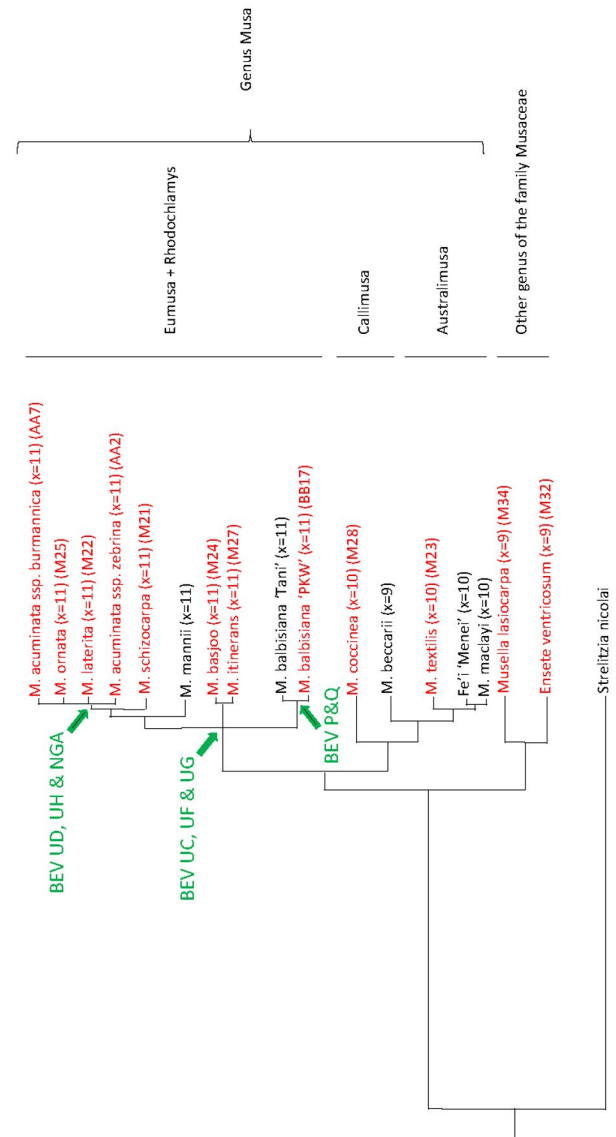

FIGURE 6 Schematic phylogenetic tree of BEV fixation events relative to speciation events within the family Musaceae constructed using nodes supported from the latest *Musa* phylogenies (Christelova et al., 2011; Janssens et al., 2016; Li et al., 2010). Banana samples from different sections of the genus *Musa* and other genera of the family Musaceae are represented. Samples characterized during this work are in red. *M. acuminata* and *M. balbisiana* subspecies are represented by samples AA2 and AA7, respectively. Green arrows, BEV fixation events; X, number of chromosomes

Harper et al., 2005, were respectively submitted to GenBank as BSUIV, BSUJV, BSUKV, BSULV, and BSUMV). Importantly, no sequences corresponding to BSUIV, BSULV, and BSUMV have so far been found integrated in banana plants (Figure 2a). The diversity of viruses from clade 3 observed nowadays is therefore more likely due either to introduction of infected banana cultivars from different locations or to host shifts between banana and other plants (Iskra-Caruana et al., 2014).

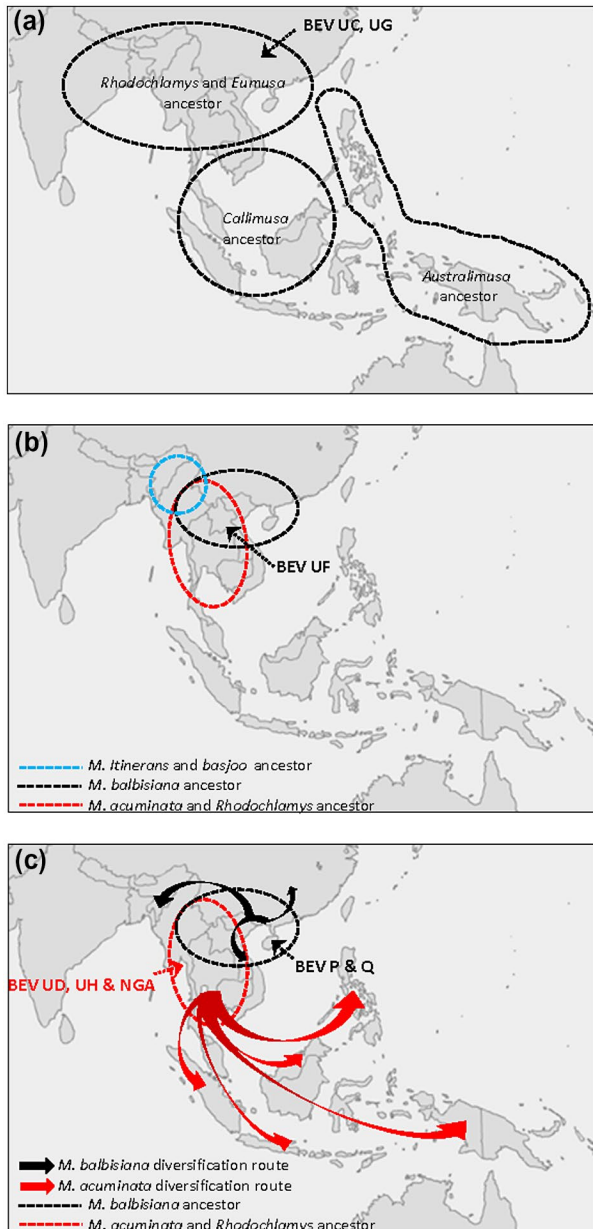

FIGURE 7 Geographical distribution of main sections of the genus *Musa* and subspecies *Eumusa* along with proposed BEV fixation events. A first wave of BEV fixation (BEV UC and UG) occurred in the *Rhodochlamys* and *Eumusa* ancestor (a). A second wave of integration fixed BEV UF in the *M. balbisiana*/*M. acuminata*/*Rhodochlamys* ancestor but not in the *M. itinerans*/*M. basjoo* ancestor (b). The boundaries of the *M. itinerans*/*M. basjoo* ancestor are uncertain. Finally, a third wave of BEV fixation occurred in *M. acuminata* (BEV UD, UH, and NGA) and *M. balbisiana* (P and Q) ancestors prior to diversification of both subspecies (c). *M. balbisiana* and *M. acuminata* diversification routes are illustrated by black and red arrows, respectively. All BEV integration and fixation events proposed took place in South/South-East continental Asia. The figure was inspired by Simmonds (1962), De Langhe et al. (2009), and Perrier et al. (2011)

3.3 | What can BEVs tell us about the banana phylogeny?

BEVs phylogeny suggests two close (in terms of parsimony) scenarios of banana genome integration: (a) a unique integration event before emergence of Musaceae, associated with several gene duplications and losses in some *Musa* subgroups; and (b) multiple integrations, whereby badnavirus ancestors of BEVs integrated into the banana genome in at least three waves corresponding to distinct periods of banana evolution, as proposed by Yu et al. (2019) for other endogenous pararetroviruses in Citrinae. Synteny analyses between the *M. acuminata* Pahang (D'Hont et al., 2012) and PKW (Wang et al., 2019) genomes found no evidence that any BEV-containing loci were identical. This is not too surprising considering that the number of initial integrations is low, and that only half of the genomes of these two sequenced plants are being examined, because each derives from a duplication of an initial haploid plant. On the other hand, because genomes A and B diverged 4.5 million years ago (Lescot et al., 2008), the initial integration loci may have diverged sufficiently so as to no longer be identified during synteny analyses. Therefore, based on recently published banana phylogenies (Christelova et al., 2011; Janssens et al., 2016; Li et al., 2010), we propose a speculative scheme (Figure 6) depicting each BEV integration event for scenario (b) with regards to the main speciation events reported within the family Musaceae.

The presence of BEVs UC, UF, and UG within both *M. acuminata* and *M. balbisiana* genomes, as well as other species of the genus *Musa* (*M. basjoo*, *M. itinerans*, *M. laterita*, or *M. ornata*), could represent the first and second integration waves (Figure 7a,b). Indeed, BEV UF integration may have followed that of BEV UC and BEV UG because *M. basjoo* and *M. itinerans* genomes do not harbour BEV UF integrations (Table 3). Interestingly, amongst *Musa* sections, BEVs are present only in *Rhodochlamys* (*M. laterita* and *M. ornata*) and *Eumusa* (*M. acuminata*, *M. balbisiana*, *M. schizocarpa*, *M. basjoo*, and *M. itinerans*) and are absent from both *Australimusa* (*M. textilis*) and *Callimusa* (*M. coccinea*)—phylogenetically very distant from *Rhodochlamys* and *Eumusa* (Christelova et al., 2011; Li et al., 2010). According to estimates of species divergence times within the family Musaceae (Christelova et al., 2011), integrations of BEVs UC, UF, UG took place between c.28 and 50 million years ago, corresponding to speciation events within *Rhodochlamys*/*Eumusa* and the age of the genus *Musa*, respectively. Importantly, based on the known geographical distribution of the main sections of the genus *Musa* (De Langhe et al., 2009) and the *M. acuminata* and *M. balbisiana* subspecies (Perrier et al., 2011), the absence of BEV in *Australimusa* and *Callimusa* genomes, and their presence in all *M. acuminata* and *M. balbisiana* subspecies, indicates that initial badnavirus infections of the *Musa* ancestor and viral integration of BEVs UC, UF, and UG occurred in South/South-East continental Asia (Figure 7a). Using the BEV markers developed here, we can

TABLE 4 Description of plant material used in this study

Genus or section in the family Musaceae	Species/subspecies	Common name	Genome	Accession number	Number in that study
<i>Eumusa</i>	<i>M. acuminata</i> subsp. <i>errans</i>	Agutay	AAw	ITC1028 (NEU0033)	AA1
<i>Eumusa</i>	<i>M. acuminata</i> subsp. <i>zebrina</i>	Zebrina	AAw	ITC1177 (NEU0029)	AA2
<i>Eumusa</i>	<i>M. acuminata</i> subsp. <i>siamea</i>	Pa (Rayong)	AAw	ITC0672 (NEU0024)	AA3
<i>Eumusa</i>	<i>M. acuminata</i> subsp. <i>malaccensis</i>	Pahang	AAw	ITC0609 (NEU0013)	AA4
<i>Eumusa</i>	<i>M. acuminata</i> subsp. <i>malaccensis</i>	THA018	AAw	ITC1067 (NEU0034)	AA5
<i>Eumusa</i>	<i>M. acuminata</i> subsp. <i>truncata</i>	Truncata	AAw	(NEU0027)	AA6
<i>Eumusa</i>	<i>M. acuminata</i> subsp. <i>burmannica</i>	Long Tavoy	AAw	ITC0283 (NEU0016)	AA7
<i>Eumusa</i>	<i>M. acuminata</i> subsp. <i>microcarpa</i>	Bornéo	AAw	ITC0253 (NEU0028)	AA8
<i>Eumusa</i>	<i>M. acuminata</i> subsp. <i>malaccensis</i>	Malaccensis	AAw	ITC0250	AA9
<i>Eumusa</i>	<i>M. acuminata</i>	Wikago	AAcv	NEU0102 (ITC0888)	AA10
<i>Eumusa</i>	<i>M. acuminata</i> subsp. <i>siamea</i>	Khao (Phrae)	AAw	ITC0660 (NEU0025)	AA11
<i>Eumusa</i>	<i>M. acuminata</i> subsp. <i>malaccensis</i>		AAw	ITC0399	AA12
<i>Eumusa</i>	<i>M. acuminata</i> subsp. <i>burmannicoides</i>	Calcutta 4	AAw	ITC0249 (NEU0017)	AA13
<i>Eumusa</i>	<i>M. acuminata</i> subsp. <i>siamea</i>	Pa (Songkhla)	AAw	ITC0408 (NEU0043)	AA14
<i>Eumusa</i>	<i>M. acuminata</i> subsp. <i>banksii</i>	Madang	AAw	ITC0254	AA26
<i>Eumusa</i>	<i>M. balbisiana</i>	Honduras	BBw	ITC0247 (NEU0049)	BB15
<i>Eumusa</i>	<i>M. balbisiana</i>	Cameroun	BBw	ITC0246 (NEU0050)	BB16
<i>Eumusa</i>	<i>M. balbisiana</i>	Pisang Klutuk Wulung	BBw	ITC1063 (NEU0056)	BB17
<i>Eumusa</i>	<i>M. balbisiana</i>	Butuhan	BBw	ITC0565	BB18
<i>Eumusa</i>	<i>M. balbisiana</i>	Lal Velchi	BBw	NEU0051	BB19
<i>Eumusa</i>	<i>M. balbisiana</i>	Papouasie New Guinea	BBw	ITC0626	BB20
<i>Eumusa</i>	<i>M. schizocarpa</i>		SS	ITC856	M21
<i>Rhodochlamys</i>	<i>M. laterita</i>			NEU0008	M22
<i>Australimusa</i>	<i>M. textilis</i>		TT	ITC1072 (NEU0001)	M23
<i>Eumusa</i>	<i>M. basjoo</i>			NEU0060	M24
<i>Rhodochlamys</i>	<i>M. ornata</i>			NEU0007	M25
<i>Eumusa</i>	<i>M. itinerans</i>				M27
<i>Callimusa</i>	<i>M. coccinea</i>			ITC0287 (NEU0003)	M28
<i>Ensete</i>	<i>Ensete ventricosum</i>				M32
<i>Musella</i>	<i>Musella lasiocarpa</i>				M34

Note. ITC numbers, accession codes from the International Transit Center, Catholic University, Leuven, Belgium; NEU numbers, accession codes from the Banana collection of CIRAD Neufchateau, Guadeloupe, France; AAw or AAcv, wild or cultivar of diploid *acuminata* bananas; BBw, wild diploid *balbisiana* bananas; M, other species from the family Musaceae. Sections *Eumusa*, *Rhodochlamys*, *Callimusa*, and *Australimusa* correspond to subsections in the genus *Musa*.

further restrict the origin of the *Eumusa/Rhodochlamys* ancestor to the south mainland of Asia, thus narrowing considerably the area defined initially by De Langhe et al. (2009).

Alternatively, virus ancestors of BEVs UC, UF, and UG could have integrated independently and randomly into different *Musa* genomes. This hypothesis is less parsimonious because it requires that at least three distinct viruses (BEVs UC, UF, and UG) integrated into different *Musa* genomes over time and in different geographical areas.

The presence of BEVs UD, UH, and NGA only in the genome of *M. acuminata*, in contrast to the absence of BEVs P and Q (present

only in *M. balbisiana*), suggests a third wave of integrations occurring after *M. acuminata* and *M. balbisiana* speciation (Figures 6 and 7c) in scenario (b). Considering the close phylogenetic relationship of BEVs UF and UD (Figure 4), we propose that BEV UD emerged after a duplication of BEV UF in *M. acuminata* only. Interestingly, Southern blot hybridization patterns clearly indicate that this integration occurred after speciation of *M. acuminata/M. balbisiana* but before species diversification. This third wave of integration seems likely to have been a host response to different viral pressures, namely BEVs P and Q for *M. balbisiana* and BEVs NGA, UD, and UH for *M. acuminata*, which come from different geographical

areas (Perrier et al., 2011) (Figure 7b,c). Interestingly, within the genus *Musa*, PCR and Southern blot profiles of BEV species suggest a close relationship between *M. acuminata* subspecies and banana species from section *Rhodochlamys* (*M. ornata* M25 and *M. laterita* M22), in agreement with published *Musa* phylogeny (Christelova et al., 2011; Li et al., 2010). Similarly, profiles of *M. basjoo* (M24) and *M. itinerans* (M27) are barely distinguishable, again corroborating their closeness in *Musa* phylogeny (Li et al., 2010). Notably, both exhibit intermediate BEV profiles compared with *M. acuminata* and *M. balbisiana*, supporting their equidistant position from the latter in the phylogenetic tree of Musaceae (Li et al., 2010).

Duroy et al. (2016) previously demonstrated eBSV to be relevant phylogenetic markers to illustrate the *M. balbisiana* phylogeographic story. In light of our data, and given the high polymorphism of BEVs within *M. acuminata* species, BEV patterns can be added to the arsenal of phylogenetic markers to describe and complete *Musa* phylogeny.

4 | EXPERIMENTAL PROCEDURES

4.1 | Plant material

Leaf samples from 109 East African Highland banana plants representing five clone sets encompassing EAH AAA banana genetic diversity (Nakitembe [32], Musakala [19], Nakabulu [16], Nfuuka [23], and Nvide [beer cultivar, 19]; Karamura & Pickersgill, 1999) were collected in Uganda in 2009; 91 samples showed typical banana leaf streak mosaic symptoms, indicating BSV infection.

We also analysed 30 samples encompassing different *M. acuminata* (AA1-AA14, AA26) and *M. balbisiana* (BB15-BB20) diploid subspecies, along with other species from the genus *Musa* (M21-M25, M27, and M28) and other genera of the family Musaceae (M32 and M34) (Table 4). Samples were collected in the Banana field collection of CIRAD Neufchateau, Guadeloupe, France.

4.2 | Extraction of genomic DNA from banana

Genomic DNA was extracted from fresh or frozen banana leaf tissue using the method of Gawel and Jarret (1991).

4.3 | Immunocapture PCR detection

BSV species were detected by IC-PCR according to a procedure adapted from Le Provost et al. (2006) using specific BSOLV, BSGFV, BSIMV, and BSMYV primers (Table 1) and a polyclonal antiserum raised against a cocktail of purified BSV species and SCBV species (kindly provided by B.E.L. Lockhart). To avoid contamination by plant genomic DNA, samples were treated with RNase-free

DNase I (Promega). DNase mix (3 μ l of 10 \times buffer [400 mM Tris, HCl pH 8, 100 mM MgSO₄, 10 mM CaCl₂], 3 μ l of DNase I [1 U/ μ l], and 24 μ l of water) was added to coated tubes and incubated for 1 hr at 37 °C. The supernatant was removed and the tubes washed once with water. DNase I was inactivated by incubation at 95 °C for 10 min.

4.4 | PCR, cloning, and sequencing

Primers in the RTase/RNase H region of badnavirus ORF III were designed to specifically detect each Ugandan badnaviral species of clades 2 and 3 (Table 1). PCR was performed with 1 U GoTaq DNA polymerase according to the manufacturer's instructions (Promega) and the following thermal cycling conditions: 1 cycle at 94 °C for 4 min; 35 cycles at 94 °C for 30 s, T_m (Table 1) for 30 s, 72 °C for 30 s; followed by 1 cycle at 72 °C for 10 min. PCR fragments were sequenced by Beckman Coulter Genomics (UK).

PCR products used as probes for Southern blot hybridization were gel-purified using the Wizard SV Gel and PCR Clean-up System (Promega) and cloned into the pGEM-T Easy vector according to the manufacturer's instructions (Promega).

4.5 | Southern blot hybridization

Total genomic DNA (40 μ g per sample) was digested overnight with 1 U/ μ g DNA for each enzyme in a final volume of 200 μ l; *Hind*III for samples representative of the *Musa* diversity, and *Kpn*I or *Alw*441 for EAH banana samples. Samples were separated by electrophoresis on 1% agarose gels and capillary-transferred overnight to Hybond N+ membrane (Amersham Biosciences) in 20 \times saline-sodium citrate (SSC) buffer. Nucleic acids were fixed onto the membrane using a UV crosslinker (70,000 μ J/cm²), then prehybridized in 20 ml of buffer (50 mM Tris.HCl pH 8, 25 mM EDTA, 5 \times SSC, 1% sodium dodecyl sulphate [SDS], 2.5 \times Denhardt's solution and 2 mg denatured salmon sperm DNA) and incubated for 3 hr at 65 °C.

Fragments corresponding to RTase/RNaseH regions of each species of clade 3 (BSUIV, BSULV, BSUMV) and each group of clade 2 (BEVs UC, UD, UF, UG, UH, P, Q, NGA) were released from pGEM-T Easy plasmids using *Eco*RI digestion and used as probes. DNA probe (50 ng) was labelled with [α -³²P] dCTP using a random priming protocol (Prime-a-Gene kit, Promega). Labelled probe was then added to 20 ml of hybridization solution (as above + 5% dextran sulphate) and incubated overnight at 65 °C. To remove non-specific hybridization signal, membranes were washed at 65 °C for 10 min, twice in SSC with 0.1% SDS solution and once in 0.5 \times SSC with 0.1% SDS. Additional washes, if required, used 0.2 \times SSC with 0.1% SDS solution. Membranes were wrapped in transparent plastic (Scel O Fraiss) and screen scanned after overnight exposure on a filmless autoradiography Typhoon FLA 9000 imaging system (GE Healthcare).

4.6 | Rolling circle amplification

DNA was amplified using a TempliPhi Amplification kit (GE Healthcare) following the protocol described by James et al. (2011). Reaction products were digested using 2 U of different restriction endonucleases (Promega), according to the manufacturer's instructions, and then separated by electrophoresis in 1% agarose gels.

4.7 | Phylogenetic analysis

Badnaviral sequences were aligned using the MAFFT software algorithm (Kato & Standley, 2013). Phylogenetic trees were constructed using the maximum-likelihood method with PhyML 3.0 (Guindon et al., 2010) and visualized using Darwin 5 software (Perrier et al., 2003). The robustness of trees was tested with aLRT-SH-like statistical support (Anisimova et al., 2011). The new sequences produced during this work have GenBank accession numbers KJ720037–KJ720154 and KJ734678–KJ734703.

ACKNOWLEDGMENTS

We are very grateful to Jerome Kubiriba from the National Agricultural Research Organisation (NARO), Jim Lorenzen (previously IITA), and farmers in Uganda for assistance with field sampling. We would like to thank the Guadeloupe Centre de Ressources Biologiques Plantes Tropicales and especially Nilda Paulo de la Reberdière and Danièle Roques for providing plant material. We also thank CIRAD for funding.

DATA AVAILABILITY STATEMENT

The data that support the findings of this study are openly available in NCBI GenBank at <https://www.ncbi.nlm.nih.gov/nucleotide>, reference numbers KJ720037–KJ720154 and KJ734678–KJ734703.

ORCID

Matthieu Chabannes  <https://orcid.org/0000-0001-5754-5982>

Marie-Line Iskra-Caruana  <https://orcid.org/0000-0003-4486-2449>

[org/0000-0003-4486-2449](https://orcid.org/0000-0003-4486-2449)

Emmanuelle Muller  <https://orcid.org/0000-0003-3292-4809>

REFERENCES

- Anisimova, M., Gil, M., Dufayard, J.-F., Dessimoz, C. & Gascuel, O. (2011) Survey of branch support methods demonstrates accuracy, power, and robustness of fast likelihood-based approximation schemes. *Systematic Biology*, 60(), 685–699.
- Bertsch, C., Beuve, M., Dolja, V.V., Wirth, M., Pelsy, F., Herrbach, E. et al. (2009) Retention of the virus-derived sequences in the nuclear genome of grapevine as a potential pathway to virus resistance. *Biology Direct*, 4, 21.
- Carreel, F. (1994) *Etude de la diversité génétique des bananiers (genre Musa) à l'aide des marqueurs RFLP*. Paris, France: Institut National Agronomique Paris-Grignon.
- Carreel, F., Gonzalez de Leon, D., Lagoda, P., Lanaud, C., Jenny, C., Horry, J.P. et al. (2002) Ascertaining maternal and paternal lineage within *Musa* by chloroplast and mitochondrial DNA RFLP analyses. *Genome*, 45, 679–692.
- Chabannes, M., Baurens, F.-C., Duroy, P.-O., Bocs, S., Vernerey, M.-S., Rodier-Goud, M. et al. (2013) Three infectious viral species lying in wait in the banana genome. *Journal of Virology*, 87, 8624–8637.
- Chabannes, M. & Iskra-Caruana, M.L. (2013) Endogenous pararetroviruses—a reservoir of virus infection in plants. *Current Opinion in Virology*, 3, 615–620.
- Christelova, P., Valarik, M., Hribova, E., De Langhe, E. & Dolezel, J. (2011) A multi gene sequence-based phylogeny of the Musaceae (banana) family. *BMC Evolutionary Biology*, 11, 103.
- D'Hont, A., Denoeud, F., Aury, J.M., Baurens, F.C., Carreel, F., Garsmeur, O. et al. (2012) The banana (*Musa acuminata*) genome and the evolution of monocotyledonous plants. *Nature*, 488, 213–217.
- Daniells, J., Jenny, C., Karamura, D. & Tomekpe, K. (2001a) *Musalogue: A catalogue of Musa germplasm. Diversity in the genus Musa*. Montpellier, France: Compiled by Arnaud, E. and Sharrock, S. International Network for the Improvement of Banana and Plantain.
- Daniells, J.W., Geering, A.D.W., Bryde, N.J. & Thomas, J.E. (2001b) The effect of Banana streak virus on the growth and yield of dessert bananas in tropical Australia. *Annals of Applied Biology*, 139, 51–60.
- De Langhe, E., Vrydaghs, L., De Maret, P., Perrier, X. & Denham, T. (2009) Why bananas matter: An introduction to the history of banana domestication. *Ethnobotany Research and Applications*, 7, 199–216.
- Duroy, P.-O., Perrier, X., Laboureau, N., Jacquemoud-Collet, J.P. & Iskra-Caruana, M.L. (2016) How endogenous plant pararetroviruses shed light on *Musa* evolution. *Annals of Botany*, 117, 625–641.
- FAOStat (2014) *FAO production statistics for banana and plantain 2012*. Rome, Italy: FAO.
- Feschotte, C. & Gilbert, C. (2012) Endogenous viruses: insights into viral evolution and impact on host biology. *Nature Reviews Genetics*, 13, 283–296.
- Gambley, C.F., Geering, A.D., Steele, V. & Thomas, J.E. (2008) Identification of viral and non-viral reverse transcribing elements in pineapple (*Ananas comosus*), including members of two new badnavirus species. *Archives of Virology*, 153, 1599–1604.
- Gawel, N.J. & Jarret, R.L. (1991) A modified CTAB DNA extraction procedure for *Musa* and *Ipomoea*. *Plant Molecular Biology Reporter*, 9, 262–266.
- Gayral, P., Blondin, L., Guidolin, O., Carreel, F., Hippolyte, I., Perrier, X. et al. (2010) Evolution of endogenous sequences of banana streak virus: what can we learn from banana (*Musa* sp.) evolution? *Journal of Virology*, 84, 7346–7359.
- Gayral, P. & Iskra-Caruana, M.-L. (2009) Phylogeny of *Banana streak virus* reveals a recent burst of integrations in the genome of banana (*Musa* sp.). *Journal of Molecular Evolution*, 69, 65–80.
- Gayral, P., Noa-Carrazana, J.C., Lescot, M., Lheureux, F., Lockhart, B.E., Matsumoto, T. et al. (2008) A single *Banana streak virus* integration event in the banana genome as the origin of infectious endogenous pararetrovirus. *Journal of Virology*, 82, 6697–6710.
- Geering, A.D., Olszewski, N.E., Dahal, G., Thomas, J.E. & Lockhart, B.E. (2001) Analysis of the distribution and structure of integrated *Banana streak virus* DNA in a range of *Musa* cultivars. *Molecular Plant Pathology*, 2, 207–213.
- Geering, A.D.W., Olszewski, N., Harper, G., Lockhart, B., Hull, R. & Thomas, J.E. (2005) Banana contains a diverse array of endogenous badnaviruses. *Journal of General Virology*, 86, 511–520.
- Geering, A.D., Parry, J.N. & Thomas, J.E. (2011) Complete genome sequence of a novel badnavirus, banana streak IM virus. *Archives of Virology*, 156, 733–737.
- Geijskes, R.J., Braithwaite, K.S., Smith, G.R., Dale, J.L. & Harding, R.M. (2004) Sugarcane bacilliform virus encapsidates genome concatamers and does not appear to integrate into the *Saccharum officinarum* genome. *Archives of Virology*, 149, 791–798.

- Gregor, W., Mette, M.F., Staginnus, C., Matzke, M.A. & Matzke, A.J. (2004) A distinct endogenous pararetrovirus family in *Nicotiana tomentosiformis*, a diploid progenitor of polyploid tobacco. *Plant Physiology*, 134, 1191–1199.
- Guindon, S., Dufayard, J.-F., Lefort, V., Anisimova, M., Hordijk, W. & Gascuel, O. (2010) New algorithms and methods to estimate maximum-likelihood phylogenies: assessing the performance of PhyML 3.0. *Systematic Biology*, 59, 307–321.
- Hansen, C.N., Harper, G. & Heslop-Harrison, J.S. (2005) Characterisation of pararetrovirus-like sequences in the genome of potato (*Solanum tuberosum*). *Cytogenetic and Genome Research*, 110, 559–565.
- Harper, G., Hart, D., Moul, S., Hull, R., Geering, A. & Thomas, J. (2005) The diversity of Banana streak virus isolates in Uganda. *Archives of Virology*, 150, 2407–2420.
- Harper, G. & Hull, R. (1998) Cloning and sequence analysis of banana streak virus. *Virus Genes*, 17, 271–278.
- Harper, G., Osuji, J.O., Heslop-Harrison, J.S. & Hull, R. (1999) Integration of banana streak badnavirus into the *Musa* genome: molecular and cytogenetic evidence. *Virology*, 255, 207–213.
- Holmes, E.C. (2011) The evolution of endogenous viral elements. *Cell Host & Microbe*, 10, 368–377.
- Hull, R. (2002) *Matthew's plant virology*. San Diego: Academic Press.
- Iskra-Caruana, M.-L., Baurens, F.-C., Gayral, P. & Chabannes, M. (2010) A four-partner plant-virus interaction: enemies can also come from within. *Molecular Plant-Microbe Interaction*, 23, 1394–1402.
- Iskra-Caruana, M.L., Duroy, P.-O., Chabannes, M. & Muller, E. (2014) The common evolutionary history of badnaviruses and banana. *Infection, Genetics and Evolution*, 21, 83–89.
- Jakowitsch, J., Mette, M.F., van Der Winden, J., Matzke, M.A. & Matzke, A.J. (1999) Integrated pararetroviral sequences define a unique class of dispersed repetitive DNA in plants. *Proceedings of the National Academy of Sciences of the United States of America*, 96, 13241–13246.
- James, A.P., Geijskes, R.J., Dale, J.L. & Harding, R.M. (2011) Molecular characterisation of six badnavirus species associated with leaf streak disease of banana in East Africa. *Annals of Applied Biology*, 158, 346–353.
- Janssens, S.B., Vandeloock, F., De Langhe, E., Verstraete, B., Smets, E., Vandenhoutte, I. et al. (2016) Evolutionary dynamics and biogeography of the Musaceae reveal a correlation between the diversification of the banana family and the geological and climatic history of Southeast Asia. *New Phytologist*, 210, 1453–1465.
- Karamura, D.A., Karamura, E.B. & Gold, C.S. (1996) Cultivar distribution in primary banana growing regions of Uganda. *MusAfrica*, 9, 3–5.
- Karamura, D. & Pickersgill, B. (1999) A classification of the clones of East African highland banana (*Musa*) found in Uganda. *Plant Genetic Resources Newsletter*, 119, 1–6.
- Katoh, K. & Standley, D.M. (2013) MAFFT multiple sequence alignment software version 7: improvements in performance and usability. *Molecular Biology and Evolution*, 30, 772–780.
- Kubiriba, J., Legg, J.P., Tushemereirwe, W. & Adipala, E. (2001) Disease spread patterns of banana streak virus in farmers' fields in Uganda. *Annals of Applied Biology*, 139, 31–36.
- Kubiriba, J., Tushemereirwe, W. & Karamura, E.B. (1997) Distribution of banana streak virus in Uganda. *MusAfrica*, 11, 17.
- Kunii, M., Kanda, M., Nagano, H., Uyeda, I., Kishima, Y. & Sano, Y. (2004) Reconstruction of putative DNA virus from endogenous rice tungro bacilliform virus-like sequences in the rice genome: implications for integration and evolution. *BMC Genomics*, 5, 80.
- Laney, A.G., Hassan, M. & Tzanetakis, I.E. (2012) An integrated badnavirus is prevalent in fig germplasm. *Phytopathology*, 102, 1182–1189.
- Le Provost, G., Iskra-Caruana, M.-L., Acina, I. & Teycheney, P.-Y. (2006) Improved detection of episomal banana streak viruses by multiplex immunocapture PCR. *Journal of Virological Methods*, 137, 7–13.
- Lescot, M., Piffanelli, P., Ciampi, A.Y., Ruiz, M., Blanc, G., Leebens-Mack, J. et al. (2008) Insights into the *Musa* genome: syntenic relationships to rice and between *Musa* species. *BMC Genomics*, 9, 58.
- Li, L.F., Hakkinen, M., Yuan, Y.M., Hao, G. & Ge, X.J. (2010) Molecular phylogeny and systematics of the banana family (Musaceae) inferred from multiple nuclear and chloroplast DNA fragments, with a special reference to the genus *Musa*. *Molecular and Phylogenetic Evolution*, 57, 1–10.
- Lockhart, B.E.L. & Jones, D.R. (2000) Banana streak. In: Jones, D.R. (Ed.), *Diseases of banana, abaca and enset*. Wallingford, UK: CAB International, pp. 263–274.
- Ndowora, T., Dahal, G., La Fleur, D., Harper, G., Hull, R., Olszewski, N.E. et al. (1999) Evidence that badnavirus infection in *Musa* can originate from integrated pararetroviral sequences. *Virology*, 255, 214–220.
- Pahalawatta, V., Druffel, K. & Pappu, H. (2008) A new and distinct species in the genus *Caulimovirus* exists as an endogenous plant pararetroviral sequence in its host, *Dahlia variabilis*. *Virology*, 376, 253–257.
- Perrier, X., De Langhe, E., Donohue, M., Lentfer, C., Vrydaghs, L., Bakry, F. et al. (2011) Multidisciplinary perspectives on banana (*Musa* spp.) domestication. *Proceedings of the National Academy of Sciences of the United States of America*, 108, 11311–11318.
- Perrier, X., Flori, A. & Bonnot, F. (2003) Data analysis methods. In: Hamon, P., Seguin, M., Perrier, X. & Glaszmann, J.C. (Eds.) *Genetic Diversity of Cultivated Tropical Plants*. Montpellier: Enfield Science Publishers, pp. 43–76.
- Richert-Poggeler, K.R., Noreen, F., Schwarzacher, T., Harper, G. & Hohn, T. (2003) Induction of infectious petunia vein clearing (pararetro) virus from endogenous provirus in petunia. *EMBO Journal*, 22, 4836–4845.
- Richert-Poggeler, K.R. & Shepherd, R.J. (1997) Petunia vein-clearing virus: a plant pararetrovirus with the core sequences for an integrase function. *Virology*, 236, 137–146.
- Simmonds, N.W. (1962) *The evolution of the bananas*. London: Longmans.
- Staginnus, C., Gregor, W., Mette, M.F., Teo, C.H., Borroto-Fernandez, E.G., Machado, M.L. et al. (2007) Endogenous pararetroviral sequences in tomato (*Solanum lycopersicum*) and related species. *BMC Plant Biology*, 7, 24.
- Wang, Z., Miao, H., Liu, J., Xu, B., Yao, X., Xu, C. et al. (2019) *Musa balbisiana* genome reveals subgenome evolution and functional divergence. *Nature Plants*, 5, 810–821.
- Yu, H., Wang, X., Lu, Z., Xu, Y., Deng, X. & Xu, Q. (2019) Endogenous pararetrovirus sequences are widely present in Citrinae genomes. *Virus Research*, 262, 48–53.

SUPPORTING INFORMATION

Additional supporting information may be found online in the Supporting Information section.)

How to cite this article: Chabannes M, Gabriel M, Aksa A, et al. Badnaviruses and banana genomes: a long association sheds light on *Musa* phylogeny and origin. *Mol Plant Pathol.* 2020;00:1–15. <https://doi.org/10.1111/mpp.13019>