



HAL
open science

Phylogenomic analysis of a 55.1 kb 19-gene dataset resolves a monophyletic *Fusarium* that includes the *Fusarium solani* species complex

David Geiser, Abdullah Al-Hatmi, Takayuki Aoki, Tsutomu Arie, Virgilio Balmas, Irene Barnes, Gary Bergstrom, M.K. Bhattacharyya, Cheryl Blomquist, Robert Bowden, et al.

► To cite this version:

David Geiser, Abdullah Al-Hatmi, Takayuki Aoki, Tsutomu Arie, Virgilio Balmas, et al.. Phylogenomic analysis of a 55.1 kb 19-gene dataset resolves a monophyletic *Fusarium* that includes the *Fusarium solani* species complex. *Phytopathology*, 2021, 111 (7), pp.1064-1079. 10.1094/phyto-08-20-0330-le . hal-03274544

HAL Id: hal-03274544

<https://hal.inrae.fr/hal-03274544v1>

Submitted on 6 Nov 2024

HAL is a multi-disciplinary open access archive for the deposit and dissemination of scientific research documents, whether they are published or not. The documents may come from teaching and research institutions in France or abroad, or from public or private research centers.

L'archive ouverte pluridisciplinaire **HAL**, est destinée au dépôt et à la diffusion de documents scientifiques de niveau recherche, publiés ou non, émanant des établissements d'enseignement et de recherche français ou étrangers, des laboratoires publics ou privés.

1 Phylogenomic analysis of a 55.1 kb 19-gene dataset resolves a monophyletic *Fusarium* that includes the
2 *Fusarium solani* Species Complex

3
4 David M. Geiser^{1,†}, Abdullah M. S. Al-Hatmi², Takayuki Aoki³, Tsutomu Arie⁴, Virgilio Balmas⁵, Irene Barnes⁶, Gary C. Bergstrom⁷,
5 Madan K. Bhattacharyya⁸, Cheryl L. Blomquist⁹, Robert L. Bowden¹⁰, Balázs Brankovics¹¹, Daren W. Brown¹², Lester W.
6 Burgess¹³, Kathryn Bushley¹⁴, Mark Busman¹², José F. Cano-Lira¹⁵, Joseph D. Carrillo¹⁶, Hao-Xun Chang¹⁷, Chi-Yu Chen¹⁸,
7 Wanquan Chen¹⁹, Martin Chilvers²⁰, Sofia Chulze²¹, Jeffrey J. Coleman²², Christina A. Cuomo²³, Z. Wilhelm de Beer⁶, G. Sybren de
8 Hoog²⁴, Johanna Del Castillo-Múnera²⁵, Emerson M. Del Ponte²⁶, Javier Diéguez-Uribeondo²⁷, Antonio Di Pietro²⁸, Véronique
9 Edel-Hermann²⁹, Wade H. Elmer³⁰, Lynn Epstein²⁵, Akif Eskalen²⁵, Maria Carmela Esposito³¹, Kathryn L. Everts³², Sylvia P.
10 Fernández-Pavía³³, Gilvan Ferreira da Silva³⁴, Nora A. Foroud³⁵, Gerda Fourie⁶, Rasmus J. N. Frandsen³⁶, Stanley Freeman³⁷,
11 Michael Freitag³⁸, Omer Frenkel³⁷, Kevin K. Fuller³⁹, Tatiana Gagkaeva⁴⁰, Donald M. Gardiner⁴¹, Anthony E. Glenn⁴², Scott E.
12 Gold⁴², Thomas R. Gordon²⁵, Nancy F. Gregory⁴³, Marieka Gryzenhout⁴⁴, Josep Guarro⁴⁵, Beth K. Gugino¹, Santiago Gutierrez⁴⁶,
13 Kim E. Hammond-Kosack⁴⁷, Linda J. Harris⁴⁸, Mónica Homa⁴⁹, Cheng-Fang Hong¹⁸, László Hornok⁵⁰, Jenn-Wen Huang¹⁸, Macit
14 Ilkit⁵¹, Adriaana Jacobs⁵², Karin Jacobs⁵³, Cong Jiang⁵⁴, María del Mar Jiménez-Gasco¹, Seogchan Kang¹, Matthew T. Kasson⁵⁵,
15 Kemal Kazan⁴¹, John C. Kennell⁵⁶, Hye-Seon Kim¹², H. Corby Kistler⁵⁷, Gretchen A. Kuldau¹, Tomasz Kulik⁵⁸, Oliver Kurzai⁵⁹, Imane
16 Laraba¹², Matthew H. Laurence⁶⁰, Theresa Lee⁶¹, Yin-Won Lee⁶², Yong-Hwan Lee⁶², John F. Leslie⁶³, Edward C.Y. Liew⁶⁰, Lily W.
17 Lofton⁴², Antonio F. Logrieco⁶⁴, Manuel S. López-Berges²⁸, Alicia G. Luque⁶⁵, Erik Lysøe⁶⁶, Li-Jun Ma⁶⁷, Robert E. Marra³⁰, Frank N.
18 Martin⁶⁸, Sara R. May¹, Susan P. McCormick¹², Chyanna McGee¹, Jacques F. Meis²⁴, Quirico Migheli⁶⁹, N. M. I. Mohamed Nor⁷⁰,
19 Michel Monod⁷¹, Antonio Moretti⁶⁴, Diane Mostert⁷², Giuseppina Mulè⁶⁴, Françoise Munaut⁷³, Gary P. Munkvold⁷⁴, Paul
20 Nicholson⁷⁵, Marcio Nucci⁷⁶, Kerry O'Donnell¹², Matias Pasquali⁷⁸, Ludwig H. Pfenning⁷⁸, Anna Prigitano³¹, Robert H. Proctor¹²,
21 Stéphane Ranque⁷⁹, Stephen A. Rehner⁸⁰, Martijn Rep⁸¹, Gerardo Rodríguez-Alvarado³³, Lindy Joy Rose⁷², Mitchell G. Roth⁸²,
22 Carmen Ruiz-Roldán²⁸, Amgad A. Saleh⁸³, Baharuddin Salleh⁷⁰, Hyunkyung Sang⁸⁴, María Mercedes Scandiani⁶⁵, Jonathan
23 Scauflaire⁸⁵, David G. Schmale III⁸⁶, Dylan P. G. Short⁸⁷, Adnan Šišić⁸⁸, Jason A. Smith⁸⁹, Christopher W. Smyth⁹⁰, Hokyoung Son⁶²,
24 Ellie Spahr⁵⁵, Jason E. Stajich⁹¹, Emma Steenkamp⁶, Christian Steinberg⁹², Rajagopal Subramaniam⁴⁸, Haruhisa Suga⁹³, Brett A.
25 Summerell⁶⁰, Antonella Susca⁶⁴, Cassandra L. Swett²⁵, Christopher Toomajian⁶³, Terry J. Torres-Cruz¹, Anna M. Tortorano³¹,
26 Martin Urban⁴⁷, Lisa J. Vaillancourt⁹⁴, Gary E. Vallad¹⁶, Theo A. J. van der Lee¹¹, Dan Vanderpool⁹⁵, Anne D. van Diepeningen¹¹,
27 Martha M. Vaughan¹², Eduard Venter⁹⁶, Marcele Vermeulen⁹⁷, Paul E. Verweij²⁴, Altus Viljoen⁷², Cees Waalwijk¹¹, Emma C.
28 Wallace¹, Grit Walther⁶¹, Jie Wang²⁰, Todd J. Ward¹², Brian L. Wickes⁹⁸, Nathan P. Wiederhold⁹⁹, Michael J. Wingfield⁶, Ana K. M.
29 Wood⁴⁷, Jin-Rong Xu¹⁰⁰, Xiao-Bing Yang⁷⁵, Tapani Yli-Mattila¹⁰¹, Sung-Hwan Yun¹⁰², Latiffah Zakaria⁷⁰, Hao Zhang¹⁹, Ning
30 Zhang¹⁰³, Sean X. Zhang¹⁰⁴, Xue Zhang⁵⁵

31
32 †Corresponding author: D. Geiser; dgeiser@psu.edu

33
34 ¹Department of Plant Pathology and Environmental Microbiology, Pennsylvania State University, University Park, PA 16802

35 ²Directorate General of Health Services, Ministry of Health, Ibb, Oman

36 ³National Agriculture and Food Research Organization, Genetic Resources Center, Tsukuba, Japan

37 ⁴Tokyo University of Agriculture and Technology, Fuchu, Japan

38 ⁵Dipartimento di Agraria, Università degli Studi di Sassari, Italy

39 ⁶Department of Biochemistry, Genetics and Microbiology, University of Pretoria, Pretoria, South Africa

40 ⁷Plant Pathology and Plant-Microbe Biology Section, Cornell University, Ithaca, NY 14853

41 ⁸Department of Agronomy, Iowa State University, Ames, IA 50011

42 ⁹Plant Pest Diagnostics Branch, California Department of Food and Agriculture, Sacramento, CA 95832

43 ¹⁰Hard Winter Wheat Genetics Research Unit, USDA-ARS, Manhattan, KS 66506

44 ¹¹Wageningen Plant Research, Wageningen University & Research, Wageningen, The Netherlands

45 ¹²Mycotoxin Prevention and Applied Microbiology Research Unit, USDA-ARS, Peoria, IL 61604

46 ¹³Sydney Institute of Agriculture, Faculty of Science, University of Sydney, Sydney, Australia

47 ¹⁴Department of Plant and Microbial Biology, University of Minnesota, St. Paul, MN 55108

48 ¹⁵Universitat Rovira i Virgili Medical School, Mycology Unit and IISPV, Reus, Spain

49 ¹⁶Gulf Coast Research and Education Center, University of Florida, Wimauma, FL 33598

50 ¹⁷Department of Plant Pathology and Microbiology, National Taiwan University, Taipei, Taiwan

51 ¹⁸Department of Plant Pathology, National Chung Hsing University, Taichung, Taiwan

52 ¹⁹State Key Laboratory for Biology of Plant Diseases and Insect Pests, Institute of Plant Protection, Chinese Academy of Agricultural Sciences,
53 Beijing, P. R. China

- 54 ²⁰Department of Plant, Soil and Microbial Sciences, Michigan State University, East Lansing, MI 48824
- 55 ²¹Research Institute on Mycology and Mycotoxicology (IMICO), National Scientific and Technical Research Council, National University of Rio
- 56 Cuarto, Rio Cuarto, Córdoba, Argentina
- 57 ²²Department of Entomology and Plant Pathology, Auburn University, Auburn, AL 36849
- 58 ²³Broad Institute of Harvard and MIT, Cambridge, MA 02142
- 59 ²⁴Department of Medical Mycology and Infectious Disease, Center of Expertise in Mycology, Radboud University Medical Center/Canisius
- 60 Wilhelmina Hospital, Nijmegen, The Netherlands
- 61 ²⁵Department of Plant Pathology, University of California-Davis, Davis, CA 95616
- 62 ²⁶Departamento de Fitopatologia, Universidade Federal de Viçosa, Viçosa, Brazil
- 63 ²⁷Department of Mycology, Real Jardín Botánico CSIC, Madrid, Spain
- 64 ²⁸Departamento de Genética, Campus de Excelencia Internacional Agroalimentario (ceiA3), Universidad de Córdoba, Córdoba, Spain
- 65 ²⁹INRAE, French National Institute for Agriculture, Food, and Environment, Dijon, France
- 66 ³⁰Department of Plant Pathology and Ecology, The Connecticut Agricultural Experiment Station, New Haven, CT 06504
- 67 ³¹Department of Biomedical Sciences for Health, Università degli Studi di Milano, Milan, Italy
- 68 ³²Wye Research and Education Center, University of Maryland, Queenstown, MD 21658
- 69 ³³Laboratorio de Patología Vegetal, IIAF, Universidad Michoacana de San Nicolás de Hidalgo, Tarímbaro, Michoacán 58880, México
- 70 ³⁴Embrapa Amazônia Ocidental, Manaus, Brazil
- 71 ³⁵Lethbridge Research and Development Centre, Agriculture and Agri-Food Canada, Lethbridge, AB, Canada T1J 4B1
- 72 ³⁶Department of Biotechnology and Biomedicine, Technical University of Denmark, Lyngby, Denmark
- 73 ³⁷Department of Plant Pathology and Weed Research, ARO, The Volcani Center, Rishon LeZion, Israel
- 74 ³⁸Department of Biochemistry and Biophysics, Oregon State University, Corvallis, OR 97331
- 75 ³⁹Department of Microbiology and Immunology, University of Oklahoma Health Sciences Center, Oklahoma City, OK 73104
- 76 ⁴⁰Laboratory of Mycology and Phytopathology, All-Russian Institute of Plant Protection, St. Petersburg-Pushkin, Russia
- 77 ⁴¹CSIRO Agriculture and Food, St. Lucia, Australia
- 78 ⁴²Toxicology & Mycotoxin Research Unit, ARS-USDA, Athens, GA 30605
- 79 ⁴³Department of Plant and Soil Sciences, University of Delaware, DE 19716
- 80 ⁴⁴Department of Genetics, University of the Free State, Bloemfontein, South Africa
- 81 ⁴⁵Unitat de Microbiologia, Departament de Ciències Mèdiques Bàsiques, Universitat Rovira i Virgili, Reus, Spain
- 82 ⁴⁶Department of Molecular Biology, Universidad de Leon, Spain
- 83 ⁴⁷Rothamsted Research, Department of Biointeractions and Crop Protection, Harpenden, United Kingdom
- 84 ⁴⁸Ottawa Research and Development Centre, Agriculture and Agri-Food Canada, Ottawa, ON, Canada K1A 0C6
- 85 ⁴⁹MTA-SZTE Fungal Pathogenicity Mechanisms Research Group, Hungarian Academy of Sciences—University of Szeged, Szeged, Hungary
- 86 ⁵⁰Institute of Plant Protection, Szent István University, Gödöllő, Hungary
- 87 ⁵¹Division of Mycology, Faculty of Medicine, University of Çukurova, Sarıçam, Adana, Turkey
- 88 ⁵²ABiosystematics Unit, Plant Health and Protection, Agricultural Research Council, Pretoria, South Africa
- 89 ⁵³Department of Microbiology, Stellenbosch University, Matieland, South Africa
- 90 ⁵⁴College of Plant Protection, Northwest Agriculture and Forestry University, Xianyang, P. R. China
- 91 ⁵⁵Division of Plant and Soil Sciences, West Virginia University, Morgantown, WV 26506
- 92 ⁵⁶Biology Department, St. Louis University, St. Louis, MO 63101
- 93 ⁵⁷USDA ARS Cereal Disease Laboratory, University of Minnesota, St. Paul, MN 55108
- 94 ⁵⁸Department of Botany and Nature Protection, University of Warmia and Mazury in Olsztyn, Olsztyn, Poland
- 95 ⁵⁹German National Reference Center for Invasive Fungal Infections NRZMyk, Leibniz Institute for Natural Product Research and Infection
- 96 Biology – Hans-Knoell-Institute, Jena, Germany
- 97 ⁶⁰Australian Institute of Botanical Science, Royal Botanic Garden and Domain Trust, Sydney, Australia
- 98 ⁶¹Microbial Safety Team, National Institute of Agricultural Sciences, RDA, Wanju, Republic of Korea
- 99 ⁶²Department of Agricultural Biotechnology, Seoul National University, Seoul, Republic of Korea
- 100 ⁶³Department of Plant Pathology, Kansas State University, Manhattan, KS 66506
- 101 ⁶⁴CNR (Research National Council), ISPA Institute of Sciences of Food Production, Bari, Italy
- 102 ⁶⁵Centro de Referencia de Micología (CEREMIC) Facultad de Ciencias Bioquímicas y Farmacéuticas, Universidad Nacional de Rosario, Rosario,
- 103 Argentina
- 104 ⁶⁶Norwegian Institute of Bioeconomy Research, Division of Biotechnology and Plant Health, Høgskoleveien, Ås, Norway
- 105 ⁶⁷Department of Biochemistry and Molecular Biology, University of Massachusetts Amherst, Amherst, MA 01003

- 106 ⁶⁸Crop Improvement and Protection Research Unit, ARS-USDA, Salinas, CA 93905
- 107 ⁶⁹Dipartimento di Agraria and Nucleo Ricerca Desertificazione (NRD), Università degli Studi di Sassari, Italy
- 108 ⁷⁰School of Biological Sciences, Universiti Sains Malaysia, Penang, Malaysia
- 109 ⁷¹Service de Dermatologie, Laboratoire de Mycologie, Centre Hospitalier Universitaire Vaudois (CHUV), 1011 Lausanne, Switzerland
- 110 ⁷²Department of Plant Pathology, Stellenbosch University, Matieland, South Africa
- 111 ⁷³Brussels, Belgium
- 112 ⁷⁴Department of Plant Pathology & Microbiology, Iowa State University, Ames, IA 50011
- 113 ⁷⁵Department of Crop Genetics, John Innes Centre, Norwich Research Park, Norwich, UK
- 114 ⁷⁶Hospital Universitário, Universidade Federal do Rio de Janeiro, Rio de Janeiro, Brazil
- 115 ⁷⁷Department of Food, Environmental and Nutritional Sciences, Università degli Studi di Milano, Milan, Italy
- 116 ⁷⁸Departamento de Fitopatologia, Universidade Federal de Lavras, Lavras, Minas Gerais State, Brazil
- 117 ⁷⁹Aix Marseille University, IHU Méditerranée Infection, Marseille, France
- 118 ⁸⁰Mycology and Nematology Genetic Diversity and Biology Laboratory, USDA-ARS, Beltsville, MD 20705
- 119 ⁸¹Swammerdam Institute for Life Science, University of Amsterdam, Amsterdam, The Netherlands
- 120 ⁸²Department of Plant Pathology, University of Wisconsin-Madison, Madison, WI 53706
- 121 ⁸³Department of Plant Protection, College of Food and Agriculture Sciences, King Saud University, Riyadh 11451, Saudi Arabia
- 122 ⁸⁴Department of Integrative Food, Bioscience and Biotechnology, Chonnam National University, Gwangju, Republic of Korea
- 123 ⁸⁵Centre de Recherche et de Formation Agronomie, Haute Ecole Louvain en Hainaut, Montignies-sur-Sambre, Belgium
- 124 ⁸⁶School of Plant and Environmental Sciences, Virginia Polytechnic Institute and State University, Blacksburg, VA 24061
- 125 ⁸⁷Amycel/Spawn Mate, San Juan Bautista, CA 95045
- 126 ⁸⁸Department of Ecological Plant Protection, University of Kassel, Witzenhausen, Germany
- 127 ⁸⁹School of Forest Resources & Conservation, University of Florida, Gainesville, FL 32611
- 128 ⁹⁰Department of Biological Sciences, Binghamton University, State University of New York, Binghamton, NY 13902
- 129 ⁹¹ Department of Microbiology and Plant Pathology, University of California-Riverside, Riverside, CA 92521
- 130 ⁹²Agroécologie, AgroSup Dijon, INRAE, University of Bourgogne Franche-Comté, Dijon, France
- 131 ⁹³Life Science Research Center, Gifu University, Gifu, Japan
- 132 ⁹⁴LDepartment of Plant Pathology, University of Kentucky, Lexington, KY 40546
- 133 ⁹⁵Department of Biology, Indiana University, Bloomington, IN 47405
- 134 ⁹⁶Department of Botany and Plant Biotechnology, University of Johannesburg, Auckland Park, South Africa
- 135 ⁹⁷Microbial Biochemical and Food Biotechnology Department, University of the Free State, Bloemfontein, South Africa
- 136 ⁹⁸Department of Microbiology, Immunology & Molecular Genetics, University of Texas Health Science Center at San Antonio, San Antonio, TX 78229
- 137 ⁹⁹Department of Pathology, University of Texas Health Science Center at San Antonio, San Antonio, TX 78229
- 138 ¹⁰⁰Department of Botany and Plant Pathology, Purdue University, West Lafayette, IN 47907
- 139 ¹⁰¹Department of Biochemistry, University of Turku, Turku, Finland
- 140 ¹⁰²Department of Medical Biotechnology, Soonchunhyang University, Asan, Republic of Korea
- 141 ¹⁰³Department of Plant Biology, Rutgers University, New Brunswick, NJ 08901
- 142 ¹⁰⁴Department of Pathology, Johns Hopkins University, Baltimore, MD 21287

144 **Abstract**

145 Scientific communication is facilitated by a data-driven, scientifically sound taxonomy that considers the
146 end-user's needs and established successful practice. Previously (Geiser et al. 2013; *Phytopathology*
147 103:400-408. 2013), the *Fusarium* community voiced near unanimous support for a concept of *Fusarium*
148 that represented a clade comprising all agriculturally and clinically important *Fusarium* species, including
149 the *F. solani* Species Complex (FSSC). Subsequently, this concept was challenged by one research group
150 (Lombard et al. 2015 *Studies in Mycology* 80: 189-245) who proposed dividing *Fusarium* into seven
151 genera, including the FSSC as the genus *Neocosmospora*, with subsequent justification based on claims
152 that the Geiser et al. (2013) concept of *Fusarium* is polyphyletic (Sandoval-Denis et al. 2018; *Persoonia*
153 41:109-129). Here we test this claim, and provide a phylogeny based on exonic nucleotide sequences of
154 19 orthologous protein-coding genes that strongly support the monophyly of *Fusarium* including the
155 FSSC. We reassert the practical and scientific argument in support of a *Fusarium* that includes the FSSC
156 and several other basal lineages, consistent with the longstanding use of this name among plant
157 pathologists, medical mycologists, quarantine officials, regulatory agencies, students and researchers
158 with a stake in its taxonomy. In recognition of this monophyly, 40 species recently described as
159 *Neocosmospora* were recombined in *Fusarium*, and nine others were renamed *Fusarium*. Here the
160 global *Fusarium* community voices strong support for the inclusion of the FSSC in *Fusarium*, as it remains
161 the best scientific, nomenclatural and practical taxonomic option available.

162

163 **Introduction**

164 Scientific advances and new fungal nomenclatural rules have forced necessary changes in fungal
165 names in recent years, many of which are inconvenient. But unlike other fungal genera where
166 phylogenetics and nomenclatural conflicts forced very difficult taxonomic decisions (e.g.,
167 *Magnaporthe/Pyricularia*; Zhang et al. 2016), there is a clear path to define *Fusarium* phylogenetically,
168 eliminate confusing dual nomenclature/taxonomy, and maintain a generic circumscription that has been
169 widely used for over a century (Bilal 1955; Booth 1971; Gams and Nirenberg 1989; Gerlach and
170 Nirenberg 1982; Joffe 1974; Leslie and Summerell 2006a; Matuo 1972; Nelson et al. 1983; Raillo 1950;
171 Snyder and Hansen 1941; Summerell 2019; Wollenweber 1913; Wollenweber and Reinking 1935). The
172 highest impact taxonomic outcome at stake is the segregation of *F. solani* and the *F. solani* Species
173 Complex (FSSC) out of *Fusarium* into the relatively obscure taxon *Neocosmospora*, the type of which
174 represents a morphologically aberrant lineage within the FSSC. Here we argue that this move is

175 scientifically unnecessary and impractical, and refute phylogenetic arguments that have been presented
176 to support it (Sandoval-Denis and Crous 2018).

177 The scientific argument for a monophyletic *Fusarium* in Geiser et al. (2013) was strongly
178 supported by 66 authors from 17 countries representing the *Fusarium* community. The goal was to
179 promote a generic concept of *Fusarium* that is scientifically (i.e., monophyletic) and nomenclaturally
180 sound, and at the same time minimizes disruption by protecting scientifically valid, longstanding use.
181 *Fusarium* is one of the most commonly used ascomycete generic names in the scientific literature
182 (Geiser et al. 2013), so this practical consideration is essential due to the negative impact of
183 disconnecting past, current and future uses of the name.

184 The Geiser et al. (2013) phylogenetic circumscription of *Fusarium* precisely corresponds to a
185 monophyletic group that encompassed all economically important *Fusarium* species, originally termed
186 the Terminal *Fusarium* Clade (herein abbreviated TFC; Gräfenhan et al. 2011). Members of this clade
187 almost always produce spores and colonies with a recognizable *Fusarium* morphology. The TFC included
188 the type species of *Fusarium*, *F. sambucinum*, the same species in which the competing teleomorph
189 genus *Gibberella* is typified: *G. pulicaris*. This overlap made it straightforward to propose unitary use of
190 the name *Fusarium* over *Gibberella* (Rossman et al. 2013). That proposal, however, did not address the
191 many *Fusarium* species within the TFC with connections to teleomorph genera other than *Gibberella*,
192 comprising the FSSC and all other Species Complexes in Figure 1 that resolve basally with respect to the
193 *F. buharicum* Species Complex.

194 Geiser et al. (2013) proposed that all members of the TFC be included in *Fusarium*, not just
195 those associated with *Gibberella*, and synonymized competing genera in the TFC under that name.
196 Based on portions of two loci (the second-largest RNA polymerase II B-subunit (*rpb2*) and larger ATP
197 citrate lyase (*acl1*) genes), the Gräfenhan et al. (2011) phylogenetic analysis provided only weak
198 statistical support for the node associated with the TFC. The proposal in Geiser et al. (2013) was based
199 on a phylogenetic analysis of a much larger set of species in the TFC that utilized more informative loci
200 (*rpb2*, as well as the largest RNA Polymerase II B-subunit gene *rpb1*; O'Donnell et al. 2013). This analysis
201 also resolved the TFC as monophyletic ("node F1"), with improved but still weak statistical support
202 (<70% maximum parsimony bootstrap (MP-BS) and maximum likelihood bootstrap (ML-BS); 1.0 Bayesian
203 posterior probability (BPP). Recognizing this uncertainty, a second node ("F2"), which received much
204 stronger statistical support (87% MP-BS; 100% ML-BS; 1.0 BPP), was offered as an alternative to F1,
205 should more rigorous analyses reject the monophyly of F1. F2 comprises all of F1 except its two basal-

206 most clades (the *F. ventricosum* and *F. dimerum* Species Complexes; FVSC and FDSC respectively).
207 Notably, both the F1 and the F2 hypotheses include the FSSC within *Fusarium*.

208 Based on a phylogenetic analysis of nine concatenated loci and a rich sampling of nectriaceous
209 taxa, Lombard et al. (2015) also resolved the same TFC node, but again with weak statistical support.
210 Although the aforementioned studies all resolved the same node, with different levels of support,
211 Sandoval-Denis and Crous (2018) claimed with no new phylogenetic evidence that the concept of
212 *Fusarium* proposed by Geiser et al. (2013) is polyphyletic. However, as carefully accounted for in Geiser
213 et al. (2013) and O'Donnell et al. (2013), statistical support for that node based on analyses of *RPB1* and
214 *RPB2* was in need of a more rigorously tested phylogeny using additional genes. In this paper, we
215 address this with a phylogenetic inference based on complete exonic nucleotide sequences of 19
216 protein-coding genes, derived from whole-genome sequences of 89 taxa, 47 of which were generated in
217 the present study (Supp. Table 1). The resulting analysis provides 100% ML-BS/1.0 BPP for the
218 monophyly of *Fusarium* as delimited by Geiser et al. (2013; i.e., the F1 node in Fig. 1), reaffirming the
219 taxonomic hypothesis that *Fusarium* has nomenclatural priority over all names typified in that clade,
220 including *Neocosmospora*.

221 We also present a phylogeny of 77 FSSC species based on three-loci: portions of *rpb2* and *tef1*
222 (translation elongation factor 1- α), and rDNA (a contiguous portion of the nuclear ribosomal RNA gene
223 repeat comprising the internal transcribed spacer (ITS) and D1-D2 regions of the nuclear large subunit).
224 Sandoval-Denis and Crous (2018) and Sandoval-Denis et al. (2019) typified and named many of the
225 previously unnamed species within the FSSC. This is an extremely important advance in the taxonomy of
226 this group, an effort and will greatly facilitate scientific communication about these fungi. However, we
227 disagree with their placement in *Neocosmospora*, for reasons we outline here and in O'Donnell et al.
228 (2020). Accordingly, we list the combinations of these taxa in *Fusarium* (Aoki et al. 2020), along with
229 other FSSC species typified or previously combined in *Neocosmospora*.

230

231 **Materials and Methods**

232 ***Selection and extraction of marker loci.*** Exonic nucleotide sequences of the 19 housekeeping genes
233 (Table 1) used to infer the *Fusarium* phylogeny in this study were selected based on (i) their use in
234 previous studies for inferring phylogenetic relationships within this genus and across the Kingdom *Fungi*
235 (Floudas et al. 2012; O'Donnell et al. 2013; Sarver et al. 2011; Villani et al. 2019; Watanabe et al. 2011);
236 (ii) their utility in previous studies of the distribution and evolution of secondary metabolite genes/gene
237 clusters in *Fusarium* (Brown and Proctor 2016; Brown et al. 2019; Busman et al. 2012; Kim et al. 2020;

238 Proctor et al. 2009, 2010, 2013, 2018) and (iii) their relative lengths. Full-length exonic sequences of
239 each gene were obtained from whole-genome sequences of 89 taxa, generated in-house at the USDA-
240 ARS-NCAUR (n=65), or by the Beijing Genome Institute (BGI; n=4), or downloaded from the GenBank
241 database at the National Center for Biotechnology Information (n=20; Suppl. Table 1).

242 Genomic DNA for sequencing was extracted from mycelia grown in liquid GYP medium (2%
243 glucose, 1% peptone, and 0.3% yeast extract) for 2 – 3 days, harvested by filtration, lyophilized, and
244 ground to a powder. Genomic DNA was then extracted using a ZR Fungal/Bacterial DNA MiniPrep kit
245 (Zymo Research, Irvine, CA), the Qiagen Genomic-Tip 20/G protocol, or a previously described
246 chloroform-phenol-based method (Raeder and Broda 1985). For data generated in-house, sequence
247 reads were generated using the MiSeq systems (Illumina) and processed using CLC Genomics
248 Workbench (CLC) versions 8 – 20 (Qiagen) as previously described (Laraba et al. 2020a, b; Proctor et al.
249 2018). Sequence reads were imported into CLC and then screened against genome sequences of 84
250 bacterial species to remove contaminating DNA introduced during library preparation and/or the
251 sequencing process. Reads were trimmed to remove low-quality data and assembled using the following
252 parameter settings in CLC: word size = 20; bubble size = 50; minimum contig length = 500; auto-detect
253 paired distances = checked; and perform scaffolding = checked.

254 Protein coding genes were predicted with the program AUGUSTUS (Stanke and Morgenstern
255 2005) using *F. graminearum* genes as a reference and the fgenesh algorithm (Solovyev et al. 2006)
256 implemented online in Softberry (<http://www.softberry.com>). Gene sequences were retrieved from
257 coding region databases of each strain using the BLASTn function in CLC Genomics Workbench and
258 query sequences from *F. fujikuroi*, *F. graminearum* and *F. vanettenii* (formerly reported as *Nectria*
259 *haematococca* mating population MPVI; Coleman et al. 2009). Sequences of each gene were aligned
260 with the query sequences using MUSCLE (Edgar 2004) as implemented in MEGA7 (Kumar et al. 2016),
261 and the resulting alignments were examined for differences between predicted coding regions and the
262 query sequences. When necessary, genes were manually annotated using genome sequence data to
263 correct errors introduced by the automated annotation, particularly with respect to predicted intron-
264 splicing sites. The three loci utilized for phylogenetic analysis of the FSSC were those utilized in previous
265 studies (O'Donnell et al. 2008; Sandoval-Denis and Crous 2019).

266 **Molecular phylogenetics.** Two multilocus datasets were assembled and analyzed using partitioned
267 maximum likelihood bootstrapping (ML-BS, 5000 replicates) with IQ-TREE 1.6.12 for MacOS (Nguyen et
268 al. 2015; <http://www.iqtree.org/>) and Bayesian inference with MrBayes v.3.2.7 (Ronquist et al. 2019). A
269 partitioned 19-gene 55.1 kb dataset was assembled to assess *Fusarium* monophyly (Table 1). It

270 contained complete exonic nucleotide sequences for 84 fusaria, a putative sister group comprising three
271 *Neonectria* species, and sequences of two non-nectriaceous hypocrealean taxa, *Beauveria bassiana*
272 (Cordycipitaceae) and *Trichoderma brevicompactum* (Hypocreaceae), which were used to root the
273 phylogeny. A partitioned 3-locus 3.2 kb dataset was constructed to infer evolutionary relationships
274 among 77 species within the FSSC, derived from previous studies (O'Donnell et al. 2008; Sandoval-Denis
275 and Crous 2019). Sequences were aligned with MUSCLE and then manually edited using TextPad 8
276 (<https://www.textpad.com>) to improve the alignment. ModelFinder (Kalyaanamoorthy et al. 2017) was
277 used to identify the best-fit model of molecular evolution for each partition based on the Bayesian
278 information criterion (BIC) scores (Chernomor et al. 2016). Bayesian inference was conducted using
279 1,000,000 generations in four chains (3 cold, and one hot, with 25% burnin), using the GTR+Γ+I
280 evolutionary model. To assess compatibility of individual loci in the phylogenetic inference, gene
281 compatibility factors (gCF) were calculated using IQ-TREE v.2.1.2 (Minh et al. 2020a,b); gCF values,
282 representing the proportion of gene partitions that resolve a particular node, were translated into
283 numerals representing the number of supporting loci out of 19. In addition, Internode Certainty (IC), IC-
284 All (ICA), Tree Certainty (TC) and relative TC values (Salichos and Rokas 2013; Salichos et al. 2014) were
285 calculated for the IQ-TREE partitioned ML tree in RAxML v.8.2.12 (Stamakis 2014; Kobert et al. 2016).
286 Aligned 19- and 3-locus datasets and best ML trees in NEXUS format, with genes partitioned as charsets,
287 are included as Supplemental Materials, and also deposited in TreeBASE (Study S27101;
288 <http://purl.org/phylo/treebase/phyloids/study/TB2:S27101>).

289

290 Results

291 **Fusarium phylogenetics.**— The 19-gene nucleotide alignment of full-length exons totalled 55,140 sites,
292 23,668 of which were parsimony informative (Table 1). Individual genes provided a range of 0.5% (*cal1*)
293 to 12.7% (*dpe1*) of the total parsimony informative sites in the concatenated character set. In the best
294 ML phylogeny (Fig. 1), 72/86 inferred nodes were supported at the 100% level by ML bootstrapping (BS)
295 as well as 1.0 Bayesian Posterior Probability (BPP), with only two nodes receiving <80% BS/<0.99 BPP
296 support (highlighted in magenta in Fig. 1). The F1/TFC node, upon which the Geiser et al. (2013)
297 circumscription was based (O'Donnell et al. 2013), received 100% BS/1.0 BPP, as did the previously
298 proposed alternate node F2. The ML and Bayesian (Suppl. Fig. 1) trees were topologically identical
299 except for placement of *F. ventricosum* within node F1 (see discussion below), which neither method
300 resolved with statistical confidence (BS <50%; 0.88 BPP for an alternative topology; see Fig. 1 and Suppl.
301 Fig. 1).

302 Based on gCF values, 53/86 internodes in the ML tree were supported by at least 16/19 loci in
303 the dataset, while 71/86 were supported by at least half (Suppl. Fig. 3). Nodes F1 and F2 were
304 supported by 12 and 14 individual loci. The most poorly supported node in the ML tree (unresolved in
305 the majority-rule bootstrap consensus tree and by Bayesian analysis) placed *F. ventricosum* as a sister to
306 the *F. dimerum* Species Complex, within the F1 node. In 7/19 individual gene trees (*act1*, *cal1*, *dpe1*,
307 *ku70*, *pgk1*, *tef1*, *tub2*; Suppl. Fig. 2), ingroup taxa (usually *F. ventricosum*) resolved among outgroup
308 taxa. These genes tend to be shorter and have lower PIC/bp values than those that resolve F1 (Table 1).
309 However, the F1/TFC, inclusive of *F. ventricosum* was supported in each of the remaining 12 individual
310 gene trees, with bootstrap values between 78-100%. Three loci, *fas1*, *fas2*, and *ku70*, representing
311 24.6% of the parsimony-informative characters in the matrix, are co-located within ~30kb on the same
312 contig (FFUJ_scaffold03) of the *F. fujikuroi* genome sequence. Removal of these linked loci and
313 reanalysis using IQ-TREE resolved the F1/TFC node with 100% ML bootstrap support (result not shown).
314 The IC and ICA values for the F1 node were 0.19 and 0.33, respectively (Suppl. Fig. 3), indicating that
315 roughly 70% of the genes support the bipartition (see Fig. 2 in Salichos et al., 2014). This value is similar
316 to the proportion of 12/19 (~63%) indicated by gCF, and evident by visual inspection of individual gene
317 trees (Suppl. Figs. 2 and 3). TC, representing the sum of IC values across trees, was 48.41, and relative
318 TC, representing TC normalized to the maximum TC for the phylogeny, was 0.563.

319 Three additional Species Complexes recognized within *Fusarium* since the publication of the
320 *rpb1 + rpb2* phylogeny (O'Donnell et al. 2013) are represented in the dataset: the *F. torreyae* Species
321 Complex (FtorSC; Zhou et al. 2018), the *F. newnesense* Species Complex (FnewSC; Laurence et al. 2016)
322 and *F. burgessii* Species Complex (FburSC, here represented by *F. beomiforme*; Laraba et al. 2018;
323 Laurence et al. 2011; Nelson and Toussoun 1987), bringing the total to 23 Species Complexes recognized
324 within the genus. Each of these Species Complexes received at least 95% ML-BS, except for the *F.*
325 *concolor* Species Complex (FconSC), which received 69% ML-BS/0.98 BPP support. This lack of resolution
326 appears to be due to FconSC's sister taxon, the *F. babinda* Species Complex, being represented by a
327 single taxon in the dataset. When *F. babinda* was removed, FconSC received 100% BS support (result not
328 shown). Similarly, the *F. ventricosum* Species Complex (FVSC) is represented by a single taxon on a long
329 branch, which likely explains the failure to resolve its placement (Felsenstein 1978). However, it does
330 resolve within the FTC/F1 node with 100% ML-BS and 1.0 BPP support, as it did with weaker support in
331 previous studies (Gräfenhan et al. 2011; Lombard et al. 2015; O'Donnell et al. 2013).

332 **FSSC phylogenetics.** The 3-locus DNA alignment for the FSSC comprised 3209 sites (665 for *TEF1*, 956 for
333 rDNA, 1588 for *RPB2*), 655 of which were parsimony-informative (164 for *TEF1*, 131 for rDNA, 360 for

334 *RPB2*). In the best ML cladogram, the previously identified major clades 1, 2 and 3 (O'Donnell 2000)
335 were resolved with 100% bootstrap support. Three clades with unique morphologies and host
336 associations were also resolved within the FSSC: (i) the subclade within Clade 3 that is morphologically
337 associated with *Neocosmospora*'s type (Smith 1899); (ii) the Ambrosia *Fusarium* Clade (AFC; Kasson et
338 al. 2013; O'Donnell et al. 2015); and (iii) the Soybean Sudden Death Syndrome (SDS) and Bean Root Rot
339 (BRR) pathogen clade nested in Clade 2 (Aoki et al. 2012).

340 **Taxonomy.** Recognizing that *Neocosmospora sensu* Lombard et al. (2015), Sandoval-Denis and Crous
341 (2018) and Sandoval-Denis et al. (2018, 2019) represents a later synonym of *Fusarium* under this
342 taxonomic hypothesis, species combinations (Aoki et al. 2020) are listed in Appendix A.

343 Importantly, we retained as distinct species the important soybean sudden death (SDS) and
344 bean root rot (BRR) pathogens in the FSSC, *F. phaseoli*, *F. tucumaniae*, *F. virguliforme*, *F. brasiliense*, *F.*
345 *cuneirostrum*, *F. crassistipitatum* and *F. azukicola*, which were synonymized under *F. phaseoli* by
346 Sandoval-Denis et al. (2019). The latter authors performed a split graph analysis and interpreted
347 reticulate patterns as evidence that these groups are conspecific. This is in contrast to previous work
348 providing evidence that they were genealogically exclusive (Aoki et al. 2005, 2012). However, the split
349 graph analysis was based on *tef1*, *rpb2* and *rDNA*, with only twelve parsimony informative sites among
350 these taxa, and they did not analyze the more phylogenetically informative loci that indicated
351 genealogical exclusivity among these species (Aoki et al. 2012). While the levels of sequence divergence
352 among these species were very small, and scrutiny of the species boundaries based on information-rich
353 phylogenomic datasets is encouraged, the reticulate pattern illustrating homoplasy could be due to
354 processes other than intraspecific genetic exchange, including incomplete lineage sorting and
355 convergence. The synonymization by Sandoval-Denis et al. (2019) also does not account for the
356 morphological differences among these species, nor reported distinctions in their symptomology and
357 host range (Aoki et al. 2005, 2012).

358

359 **Discussion**

360 The rationale for a phylogenetic delimitation of *Fusarium* outlined by Geiser et al. (2013), reaffirmed
361 here, can be considered on its own merit. However, we emphasize that the 166 scientists from 30
362 countries (aka core global *Fusarium* community) who co-authored the present publication
363 enthusiastically support it as the best scientifically and nomenclaturally valid taxonomic option. We
364 argue that the alternative posed by Lombard et al. (2015) is based on a taxonomic viewpoint that binds
365 the concept of *Fusarium* to a teleomorph name, *Gibberella*. This approach was first hinted at (Gräfenhan

366 et al. 2011; Schroers et al. 2011), and later manifested in a proposal (Lombard et al. 2015) to split
367 *Fusarium* into seven genera within the TFC: *Fusarium* (*Gibberella*'s de facto replacement), *Albonectria*,
368 *Bisifusarium*, *Cyanonectria*, *Geejayessia*, *Neocosmospora*, and *Rectifusarium*. Although the generic
369 concepts proposed by Lombard et al. (2015) are monophyletic and nomenclaturally valid, they fail on
370 the practicality criterion because they exclude species with a longstanding place in *Fusarium*. We see no
371 benefit in splitting *Fusarium* in favor of competing names that are largely tied to rarely observed sexual
372 stages.

373 The most important exclusion by Lombard et al. (2015) is that of the FSSC, which was moved to
374 the genus *Neocosmospora* in their taxonomic proposal. The type species, *Neocosmospora vasinfecta*,
375 which was recombined in *Fusarium* as *F. neocosmosporiellum* (Geiser et al. 2013), represents an atypical
376 morphological lineage derived within the FSSC (Figs. 1 and 2). *Fusarium neocosmosporiellum* and
377 related species produce an asexual stage that, unlike most FSSC species, lacks the fusiform sporodochial
378 macroconidia that are the hallmark of *Fusarium*, and a homothallic sexual stage consisting of smooth,
379 thin-walled perithecia and ascospores that are mostly single-celled (Smith 1899; Wollenweber and
380 Reinking 1935). However, *F. neocosmosporiellum* produces microconidiophores typical of the FSSC
381 (Domsch et al. 1980). Viewed within a robust phylogenetic framework, *F. neocosmosporiellum* clearly
382 represents a morphologically aberrant FSSC lineage whose species have lost the ability to produce the
383 iconic multiseptate macroconidia and only occasionally produce two-celled ascospores (O'Donnell 2000;
384 O'Donnell et al. 2013). Similarly, most of the 19 species in the Ambrosia *Fusarium* Clade are
385 morphologically unique within the FSSC in that they produce club-shaped macroconidia that are
386 hypothesized to be adaptive to roles associated with the ambrosia beetle symbiosis (Kasson et al. 2013).

387 While *Neocosmospora* works nomenclaturally as an available genus name typified within the
388 FSSC, it would be unfortunate if its aberrant morphology were to replace *Fusarium*, which represents
389 the dominant morphology of the group. Because *Neocosmospora* is the oldest teleomorph name
390 associated with the FSSC, this awkward nomenclatural option seemed reasonable when it was applied
391 under dual nomenclature (e.g., Nalim et al. 2011). However, the demise of dual nomenclature as of 01
392 Jan 2013 opened the door to a much more practical and attractive option: *Fusarium*, an older name, and
393 the dominant longstanding generic concept associated with the FSSC. Highlighting that status, '*Fusarium*
394 *solani*' generated over 100 times more Google hits than '*Neocosmospora*' (3,000,000 to 27,600; search
395 conducted on 09 July 2020). In summary, we argue that the practical and most scientifically attractive
396 option is to combine *Neocosmospora* species under *Fusarium* (Geiser et al. 2013), not the other way
397 around.

398 We refute the argument that inclusion of the FSSC in *Fusarium* “implies a denial of the current
399 phenotypic ... evidence” (Sandoval-Denis et al. 2019), and, to the contrary, argue that the name
400 ‘*Neocosmospora*’ is an atypical phenotypic fit for the FSSC. Sandoval-Denis et al. (2019) do not apply a
401 rigorous test or accounting of phenotypic synapomorphies that invalidate the Geiser et al. (2013)
402 circumscription. Iconic *Fusarium* multiseptate macroconidia are observed in a majority of FSSC species,
403 as they are in members of every other *Fusarium* Species Complex. In addition to the aforementioned *F.*
404 *neocosmosporiellum*, occasional isolates within multiple FSSC species appear to lack macroconidium
405 production (Gams 1971; O’Donnell 2000; Short et al. 2013; Summerbell and Schroers 2002). However,
406 the vast majority of isolates in the FSSC do produce these spores, and a lack of macroconidia is
407 occasionally observed in *Fusarium sensu* Lombard et al. (2015) as well (*e.g.*, *F. xyrophilum*: Laraba et al.
408 2020a). While the FSSC is morphologically distinguishable from other *Fusarium* Species Complexes, we
409 do not accept that these differences are sufficiently significant to require recognition as a separate
410 genus. To wit, the concept of *Fusarium* in existence for over a century has consistently accommodated
411 this level of phenotypic diversity in the recognition of taxonomic subgroups within the genus
412 (Wollenweber 1913; Wollenweber and Reinking 1935).

413 While there are indeed morphological and ecological trends associated with the phylogenetic
414 structure within our circumscription of *Fusarium*, there are no convincing nomenclatural, scientific or
415 practical criteria that obligate splitting it into multiple genera. Illustrating similarities between the FSSC
416 and other *Fusarium* clades, FSSC species share many morphological, ecological and genomic
417 characteristics with the *F. oxysporum* Species Complex (FOSC), which Lombard et al. (2015) retain in
418 *Fusarium*. FSSC and FOSC often are co-isolated from the same soil and plant samples, and while they can
419 be resolved morphologically, misidentification of one as the other is common. FSSC and the FOSC are
420 cosmopolitan residents of soil and the rhizosphere, and of decaying and living plant material, where
421 they may act as parasites and/or endophytes. Interestingly, their ecological similarities are reflected in
422 their genomes, with both having significantly expanded accessory genomes that include supernumerary,
423 conditionally dispensable chromosomes that harbor niche adaptive genes (Coleman et al. 2009; Ma et
424 al. 2010; Waalwijk et al. 2018). While these two groups occupy different clades within *Fusarium*, and
425 placing them in separate genera is a discretionary option, plant pathologists and medical mycologists
426 have treated them as congeneric for the past century. International *Fusarium* Laboratory Workshops,
427 which have been held regularly since the 1970s, (Leslie and Summerell 2006b) present the FSSC and the
428 FOSC, which is retained in *Fusarium* by Lombard et al. (2015), together in lectures and the laboratory,
429 reflecting the shared ecological, morphological and genomic characteristics that are relevant to

430 clinicians and researchers. In short, we argue that the individual lineages that comprise the
431 monophyletic *Fusarium sensu* Geiser et al. (2013) share more in common than not.

432 In support of splitting *Fusarium* into seven genera and promoting the FSSC as *Neocosmospora*,
433 additional claims were made about the status of the TFC as a monophyletic group (Sandoval-Denis and
434 Crous 2018), including: (i) the Geiser et al. (2013) concept of *Fusarium* is “polyphyletic,” and (ii) moving
435 it to *Neocosmospora* represents a “more natural classification.” To correct the record, there are no
436 published phylogenies known to the authors of this paper with appropriate taxon sampling and
437 resolving power showing the TFC to be anything but monophyletic, including the Lombard et al. (2015)
438 phylogeny. Comparisons of the phylogeny in Lombard et al. (2015) with those in Geiser et al. (2013),
439 O’Donnell et al. (2013) and Gräfenhan et al. (2011) reveal that a monophyletic TFC is resolved in **all** of
440 them. Certainly, as has been shown in many publications, there is phylogenetic structure within
441 *Fusarium*, but phylogenetic structure is not synonymous with polyphyly (i.e., having multiple distinct
442 evolutionary origins (Farris 1990)); a strongly supported monophyletic genus can encompass strongly
443 supported monophyletic subgroups. Nor would it be reasonable to argue that a genus can
444 accommodate only a certain degree of phylogenetic structure, particularly when its well-studied
445 taxonomy has unanimously accommodated substructure, in the form of Sections (Wollenweber 1913)
446 and now phylogenetic lineages referred to as Species Complexes (O’Donnell et al. 2013).

447 We also reject the assertion that splitting the FSSC off as *Neocosmospora* represents a “more
448 natural classification.” Given that *Neocosmospora sensu* Sandoval-Denis et al. (2019) and the
449 circumscription of *Fusarium* in Geiser et al. (2013) are both monophyletic, the two concepts are of equal
450 status regarding scientific support. In fact, Geiser et al. (2013) openly critiqued the phylogenetic
451 evidence underlying their taxonomic hypothesis and presented an alternative circumscription of
452 *Fusarium* in case additional data did not support this hypothesis. Although the concept proposed by
453 Geiser et al. (2013) is based on phylogenetics, it is rooted in the first taxonomic synthesis of *Fusarium*
454 (Wollenweber and Reinking, 1935), and subsequent modifications based on modern morphological (e.g.,
455 moving ‘*F. nivale*’ into *Microdochium*; Samuels and Hallett 1983) and phylogenetic (Gräfenhan et al.
456 2011; O’Donnell et al. 2013) information. It retains all agriculturally, medically and economically
457 important species in *Fusarium*. In contrast to the claim that *Neocosmospora* is the more natural
458 classification for the FSSC, we find its transfer to *Neocosmospora* unnatural in light of this historical and
459 practical context. It is a morphologically counterintuitive, unnecessarily disruptive solution to a
460 taxonomic problem that does not exist.

461 Our phylogenetic circumscription of *Fusarium* mirrors that of *Aspergillus* in several ways
462 (Samson et al. 2014). *Aspergillus* is also one of the most commonly used generic names in *Fungi*, and it
463 corresponds to a strongly supported clade (Kocsubé et al. 2016; Steenwyk et al. 2019). Both genera
464 harbor great species diversity, with new species being discovered at high rates. However, the *Aspergillus*
465 clade encompasses much greater morphological diversity than *Fusarium*, including sexual stages varying
466 from asci enclosed within wefts of hyphal elements (*Neosartorya*, associated with *A. fumigatus*) to
467 cleistothecia enclosed in sclerotial ascostromata (*Petromyces*, associated with *A. flavus*). While the
468 familiar *Aspergillus* conidiophore morphology dominates, the clade also includes aberrant anamorph
469 forms such as *Phialosimplex*. In the case of *Aspergillus*, it was decided that the broader circumscription
470 was the most reasonable solution among nomenclaturally and scientifically valid options (Samson et al.
471 2014), and all competing generic concepts have been subsumed under *Aspergillus*. While molecular
472 phylogenetic studies over the past three decades have revealed *Aspergillus* and *Fusarium* are much
473 larger than documented using morphology alone, it is important to note that both are monophyletic as
474 presently circumscribed.

475 The strong statistical support presented in the 19-locus phylogeny solidifies the taxonomic
476 hypothesis assigning the name *Fusarium* to all descendants of node F1 in Geiser et al. (2013) and
477 O'Donnell et al. (2013), and the "Terminal *Fusarium* Clade" *sensu* Gräfenhan et al. (2011). This finding
478 further negates the unsupported claim that *Fusarium sensu* Geiser et al. (2013) is polyphyletic, and it
479 eliminates any remaining doubt regarding the robustness of the TFC/F1 node. As a result, all competing
480 generic names typified in this clade, including *Albonectria*, *Bisifusarium*, *Cyanonectria*, *Geejayessia*,
481 *Gibberella*, *Neocosmospora*, and *Rectifusarium*, are recognized as *Fusarium*. With taxon discovery and
482 phylogenomic datasets rapidly accumulating, we will continue to scrutinize and refine our taxonomic
483 hypothesis and promote a scientifically robust and practical, user-friendly generic concept. As shown
484 here, consideration of additional data has significantly strengthened the inference that the present
485 circumscription of *Fusarium* is monophyletic (Geiser et al. 2013).

486 Taxonomy's purpose is to foster clear scientific communication, and the job of taxonomists is to
487 refine it with that in mind. In doing so, taxonomists must not only recommend improved communication
488 going forward, but also weigh the costs of altering longstanding, effective communication (Booth 1978).
489 This communication underlies international trade and agricultural biosecurity, pesticide and crop
490 cultivar registration, and accurate identification and reporting of etiological agents essential for plant,
491 animal and human disease management. In some cases, scientific evidence and practical merit require
492 inconvenient disruptions of and changes in taxonomic usage to accommodate nomenclatural rules and

493 scientific rigor. As spelled out here and in Geiser et al. (2013), we assert that inclusion of the FSSC in
 494 *Neocosmospora* rather than *Fusarium* is not such a case. In this age, when molecular phylogenetics is
 495 informing a vastly improved taxonomy, the *Fusarium* community is fortunate that the genus-level
 496 taxonomy is supported by a phylogenetically rigorous, nomenclaturally sound and user-friendly solution
 497 allowing uninterrupted unitary use of the name *Fusarium*. In the interest of a robust taxonomy that
 498 facilitates communication, we welcome cogent, data-driven alternative taxonomic hypotheses that fully
 499 consider the scientific, nomenclatural and practical ramifications.

500

501 **ACKNOWLEDGMENTS**

502

503 The authors thank Crystal Probyn and Amy McGovern for skilled technical assistance in various aspects
 504 of this study, and suggestions and comments on the manuscript from Antonis Rokas, Edward Kaiser and
 505 two anonymous reviewers. This research was funded by the US Department of Agriculture's Agricultural
 506 Research Service (USDA-ARS) National Program for Food Safety, NSF grant DEB-1655980, and the
 507 Pennsylvania State Agricultural Experiment Station Project 4655. This is contribution no. 21-022-J from
 508 the Kansas Agricultural Experiment Station. IL was supported through the ORISE program.

509

510 **DISCLAIMER**

511

512 The mention of company names or trade products does not imply that they are endorsed or
 513 recommended by the US Department of Agriculture over other companies or similar products not
 514 mentioned. USDA is an equal opportunity provider and employer.

515

516 **Appendix A**

517 A list of taxonomic changes follows (Aoki et al. 2020):

518 *Fusarium acutisporum* (Sand.-Den. & Crous) O'Donnell, Geiser, Kasson & T. Aoki, Index Fungorum 440: 1.
 519 2020. [IF 557667]

520 ≡ *Neocosmospora acutispora* Sand.-Den. & Crous, Persoonia 43: 108. 2019. [MB 831170]

521

522 *Fusarium ambrosium* (Gadd & Loos) Agnihotr. & Nirenberg, Stud. Mycol. 32: 98. 1990. [MB 130225]

523 ≡ *Monacrosporium ambrosium* Gadd & Loos, Trans. Br. mycol. Soc. 30: 13. 1947. [MB 288427]

524 ≡ *Neocosmospora ambrosia* (Gadd & Loos) L. Lombard & Crous, Stud. Mycol. 80: 227. 2015.

525 [MB 810957]

526 Note: Also known as FSSC 19.

527

- 528 *Fusarium amplum* (Sand.-Den. & Crous) O'Donnell, Geiser, Kasson & T. Aoki, Index Fungorum 440: 1.
529 2020. [IF 557668]
530 ≡ *Neocosmospora ampla* Sand.-Den. & Crous, Persoonia 43: 110. 2019. [MB 831171]
531
- 532 *Fusarium bataticola* (Sand.-Den. & Crous) O'Donnell, Geiser, Kasson & T. Aoki, Index Fungorum 440: 1.
533 2020. [IF 557670]
534 ≡ *Neocosmospora bataticola* Sand.-Den. & Crous, Persoonia 43: 112 2019. [MB 831172]
535 Note: Also known as FSSC 23.
536
- 537 = *Neocosmospora striata* Udagawa & Y. Horie, Trans. Mycol. Soc. Japan 16: 340. 1975. [MB 318599]
538 (non *Fusarium striatum* Sherb. 1915 [MB240201])
539 = *Neocosmospora parva* Mahoney, Mycologia 68: 1111. 1976. [MB 318598]
540 = *Fusarium solani* f. *batatas* T.T. McClure, Phytopathology 41: 75. 1951. [MB 537090] (non *Fusarium*
541 *batatas* Wollenw. 1914. [MB 175963])
542 Note: Also known as *Nectria haematococca* Mating Population II (NhMP II).
543
- 544 *Fusarium bomiense* (Z.Q. Zeng & W.Y. Zhuang) O'Donnell, Geiser, Kasson & T. Aoki, Index Fungorum 440:
545 1. 2020. [IF 557671]
546 ≡ *Neocosmospora bomiensis* Z.Q. Zeng & W.Y. Zhuang, Phytotaxa 319(2): 177. 2017. [MB 570412]
547
- 548 *Fusarium borneense* (Petr.) O'Donnell, Geiser, Kasson & T. Aoki, Index Fungorum 440: 1. 2020. [IF
549 557672]
550 ≡ *Neocosmospora borneensis* (Petr.) Sand.-Den. & Crous, Persoonia 43: 115. 2019. [MB 831173]
551 ≡ *Nectria borneensis* Petr., Sydowia 8: 20. 1954. [MB 301755]
552 Note: Also known as FSSC 30.
553
- 554 *Fusarium bostrycoides* Wollenw. & Reinking, Phytopathology 15(3): 166. 1925. [MB 258714]
555 ≡ *Neocosmospora bostrycoides* (Wollenw. & Reinking) Sand.-Den. & Crous, Persoonia 43: 115.
556 2019. [MB 831174]
557 Note: Also known as FSSC 25.
558
- 559 *Fusarium breve* (Sand.-Den. & Crous) O'Donnell, Geiser, Kasson & T. Aoki, Index Fungorum 440: 1. 2020.
560 [IF 557673]
561 ≡ *Neocosmospora brevis* Sand.-Den. & Crous, Persoonia 43: 119. 2019. [MB 831176]
562 Note: Also known as FSSC 15.
563
- 564 *Fusarium breviconum* (Wollenw.) O'Donnell, Geiser, Kasson & T. Aoki, Index Fungorum 440: 1. 2020. [IF
565 557674]
566 ≡ *Hypomyces haematococcus* var. *breviconus* Wollenw., Fusaria autographice delineata 3: no. 828.
567 1930. [MB 373029]
568 ≡ *Neocosmospora brevicona* (Wollenw.) Sand.-Den. & Crous, Persoonia 43: 117. 2019. [MB 831175]
569 ≡ *Nectria haematococca* var. *breviconica* (Wollenw.) Gerlach, Fusarium: Disease, Biology, and
570 Taxonomy (State College), p. 422. 1981. [MB 117167]
571 = *Fusarium solani* var. *minus* Wollenw., Die Fusarien, ihre Beschreibung, Schadwirkung und
572 Bekämpfung (Berlin). p. 134. 1935. [MB 185066]
573

- 574 *Fusarium catenatum* (Sand.-Den. & Crous) O'Donnell, Geiser & T. Aoki, Index Fungorum 440: 1. 2020. [IF
575 557675]
576 ≡ *Neocosmospora catenata* Sand.-Den. & Crous, Persoonia 41: 115. 2018. [MB 822898]
577 Note: Also known as FSSC 43.
578
- 579 *Fusarium crassum* (Sand.-Den. & Crous) O'Donnell, Geiser, Kasson & T. Aoki, Index Fungorum 440: 1.
580 2020. [IF 557676]
581 ≡ *Neocosmospora crassa* Sand.-Den. & Crous, Persoonia 43: 122. 2019. [MB 831177]
582 Note: Also known as FSSC 34.
583
- 584 *Fusarium croci* (Guarnaccia, Sand.-Den. & Crous) O'Donnell, Geiser & T. Aoki, Index Fungorum 440: 1.
585 2020. [IF 557677]
586 ≡ *Neocosmospora croci* Guarnaccia, Sand.-Den. & Crous, Persoonia 40: 17. 2017. [MB 820251]
587
- 588 *Fusarium cryptoseptatum* (Sand.-Den. & Crous) O'Donnell, Geiser, Kasson & T. Aoki, Index Fungorum
589 440: 1. 2020. [IF 557678]
590 ≡ *Neocosmospora cryptoseptata* Sand.-Den. & Crous, Persoonia 43: 122. 2019. [MB 831178]
591
- 592 *Fusarium cucurbiticola* O'Donnell, Geiser, Kasson & T. Aoki, Index Fungorum 440: 2. 2020. [IF 557679]
593 ≡ *Neocosmospora cucurbitae* Sand.-Den., L. Lombard & Crous, Persoonia 43: 125. 2019. [MB
594 831179] (non *Fusarium cucurbitae* Taubenh. 1920 [MB 509348])
595 = *Fusarium solani* f. *cucurbitae* W.C. Snyder & H.N. Hansen, Amer. J. Bot. 28: 740. 1941. [MB 346145]
596 = *Fusarium solani* f. sp. *cucurbitae* W.C. Snyder & H.N. Hansen, Root rots caused by Phycomycetes
597 28: 740. 1941. [MB 434083]
598 = *Hypomyces solani* f. *cucurbitae* W.C. Snyder & H.N. Hansen, Amer. J. Bot. 28: 741. 1941. [MB
599 346179]
600 ≡ *Nectria haematococca* var. *cucurbitae* (W.C. Snyder & H.N. Hansen) Dingley, New Zealand J. Agric.
601 Res. 4: 337. 1961. [MB 349909]
602 ≡ *Nectria solani* f. *cucurbitae* (W.C. Snyder & H.N. Hansen) G.R.W. Arnold, Z. Pilzk. 37: 193. 1972.
603 [MB 348526]
604 Note: Also known as *Nectria haematococca* Mating Population I (NhMPI) and FSSC 10.
605
- 606 *Fusarium cyanescens* (G.A. de Vries, de Hoog & Bruyn) O'Donnell, Geiser & T. Aoki, Index Fungorum 440:
607 2. 2020. [IF 557680]
608 ≡ *Phialophora cyanescens* G.A. de Vries, de Hoog & Bruyn, Antonie van Leeuwenhoek 50(2): 150.
609 1984. [MB 107121]
610 ≡ *Neocosmospora cyanescens* (G.A. de Vries, de Hoog & Bruyn) Summerbell, Schroers & Scott,
611 Biology of Microfungi (Cham) 183. 2016. [MB 813864]
612 ≡ *Cylindrocarpon cyanescens* (G.A. de Vries, de Hoog & Bruyn) Sigler, J. Clin. Microbiol. 29: 1858.
613 1991. [MB 499349]
614 Note: Also known as FSSC 27.
615
- 616 *Fusarium diminutum* (Sand.-Den. & Crous) O'Donnell, Geiser, Kasson & T. Aoki, Index Fungorum 440: 2.
617 2020. [IF 557681]
618 ≡ *Neocosmospora diminuta* Sand.-Den. & Crous, Persoonia 43: 127. 2019. [MB 831180]
619 Note: Also known as FSSC 39.
620

- 621 *Fusarium euwallaceae* S. Freeman, Z. Mendel, T. Aoki & O'Donnell, Mycologia 105(6): 1599. 2013. [MB
622 803293]
623 ≡ *Neocosmospora euwallaceae* (S. Freeman, Z. Mendel, T. Aoki & O'Donnell) Sand.-Den., L.
624 Lombard & Crous, Persoonia 43: 129. 2019. [MB 831181]
625
626 *Fusarium falciforme* (Carrión) Summerb. & Schroers, J. Clin. Microbiol. 40(8): 2872. 2002. [MB 483950]
627 ≡ *Cephalosporium falciforme* Carrión, Mycologia 43: 523. 1951. [MB 294124]
628 ≡ *Acremonium falciforme* (Carrión) W. Gams, Cephalosporium-artige Schimmelpilze (Stuttgart):
629 139. 1971. [MB 308145]
630 ≡ *Neocosmospora falciformis* (Carrión) L. Lombard & Crous, Stud. Mycol. 80: 227. 2015. [MB
631 810958]
632 Note: Also known as FSSC 3+4.
633
634 *Fusarium ferrugineum* (Sand.-Den. & Crous) O'Donnell, Geiser, Kasson & T. Aoki, Index Fungorum 440: 2.
635 2020. [IF 557682]
636 ≡ *Neocosmospora ferruginea* Sand.-Den. & Crous, Persoonia 43: 130. 2019. [MB 831182]
637
638 *Fusarium haematococcum* Nalim, Samuels & Geiser, Mycologia 103(6): 1322. 2011. [MB 519837]
639 = *Nectria haematococca* Berk. & Broome var. *haematococca*, J. Linn. Soc. Bot. 14: 116. 1875. [MB
640 417425]
641 ≡ *Neocosmospora haematococca* (Berk. & Broome) Nalim, Samuels & Geiser, Mycologia 103 (6):
642 1322. 2011. [MB 519835]
643 Note: Also known as FSSC 28.
644
645 *Fusarium helgardnirenbergiae* O'Donnell, Geiser, Kasson & T. Aoki, Index Fungorum 440: 2. 2020. [IF
646 557683]
647 ≡ *Neocosmospora nirenbergiana* Sand.-Den. & Crous, Persoonia 43: 143. 2019. [MB 831189] (non
648 *Fusarium nirenbergiae* L. Lombard & Crous 2018. [MB 826845])
649 Etymology: In honor of Dr. Helgard Nirenberg.
650
651 *Fusarium hengyangense* (Z.Q. Zeng & W.Y. Zhuang) O'Donnell, Geiser, Kasson & T. Aoki, Index Fungorum
652 440: 2. 2020. [IF 557684]
653 ≡ *Neocosmospora hengyangensis* Z.Q. Zeng & W.Y. Zhuang, Phytotaxa 319: 179. 2017. [MB 570411]
654
655 *Fusarium hypothenemi* (Sand.-Den. & Crous) O'Donnell, Geiser, Kasson & T. Aoki, Index Fungorum 440:
656 2. 2020. [IF 557685]
657 ≡ *Neocosmospora hypothenemi* Sand.-Den. & Crous, Persoonia 43: 132. 2019. [MB 831183]
658 Note: Also known as FSSC 38.
659
660 *Fusarium illudens* C. Booth, The genus *Fusarium*: 54. 1971. [MB 314215]
661 = *Neocosmospora illudens* (Berk.) L. Lombard & Crous, Stud. Mycol. 80: 227. 2015. [MB 810959]
662 ≡ *Nectria illudens* Berk., The botany of the Antarctic Voyage II, Flora Novae-Zealandiae 2: 203. 1855.
663 [MB 170632]
664
665 *Fusarium kelerajum* Samuels, Nalim & Geiser, Mycologia 103(6): 1326. 2011. [MB 519856]
666 = *Neocosmospora keleraja* Samuels, Nalim & Geiser, Mycologia 103(6): 1326. 2011. [MB 519854]
667

- 668 *Fusarium keratoplasticum* Geiser, O'Donnell, D.P.G. Short & Ning Zhang, Fungal Genetics Biol. 53: 68.
 669 2013 [MB 802390]
 670 ≡ *Neocosmospora keratoplastica* (Geiser, O'Donnell, D.P.G. Short & Ning Zhang) Sand.-Den. &
 671 Crous, Persoonia 41: 120. 2017 [MB 822900]
 672 Note: Also known as FSSC 2.
 673
- 674 *Fusarium kuroshium* (F. Na, J.D. Carrillo & A. Eskalen ex Sand.-Denis & Crous) O'Donnell, Geiser, Kasson
 675 & T. Aoki, Index Fungorum 440: 2. 2020. [IF 557669]
 676 ≡ *Neocosmospora kuroshio* F. Na, J.D. Carrillo & A. Eskalen ex Sand.-Den. & Crous, Persoonia 41:
 677 137. 2018. [MB 831184]
 678 (≡ *Fusarium kuroshium* F. Na, J.D. Carrillo & A. Eskalen, Plant Disease 102: 1159. 2018. Nom. inval.,
 679 Art. 40.7 [MB 821907])
 680
- 681 *Fusarium kurunegalense* Samuels, Nalim & Geiser, Mycologia 103(6): 1323. 2011. [MB 519848]
 682 = *Neocosmospora kurunegalensis* Samuels, Nalim & Geiser, Mycologia 103(6): 1324. 2011. [MB
 683 519847]
 684
- 685 *Fusarium lichenicola* C. Massal., Annales Mycologici 1(3): 223. 1903. [MB 200576]
 686 ≡ *Neocosmospora lichenicola* (C. Massal.) Sand.-Den. & Crous, Persoonia 41: 120. 2018. [MB
 687 822901]
 688 ≡ *Bactridium lichenicola* (C. Massal.) Wollenw. [as '*lichenicolum*'], Fusaria autographica delineata 1:
 689 no. 456 (1916). [MB 101879]
 690 ≡ *Cylindrocarpon lichenicola* (C. Massal.) D. Hawksw., Bull. Br. Mus. Nat. Hist., Bot. 6(3): 273. 1979.
 691 [MB 312456]
 692 Note: Also known as FSSC 16.
 693
- 694 *Fusarium liriodendri* (Sand.-Den. & Crous) O'Donnell, Geiser, Kasson & T. Aoki, Index Fungorum 440: 2.
 695 2020. [IF 557686]
 696 ≡ *Neocosmospora liriodendri* Sand.-Den. & Crous, Persoonia 43: 139. 2019. [MB 831185]
 697 Note: Also known as FSSC 24.
 698
- 699 *Fusarium macrosporum* (Sand.-Den., Guarnaccia & Polizzi) O'Donnell, Geiser & T. Aoki, Index Fungorum
 700 440: 2. 2020. [IF 557687]
 701 ≡ *Neocosmospora macrospora* Sand.-Den., Guarnaccia & Polizzi, Persoonia 40: 21. 2017. [MB
 702 820253]
 703
- 704 *Fusarium mahasenii* Samuels, Nalim & Geiser, Mycologia 103(6): 1325. 2011. [MB 519853]
 705 = *Neocosmospora mahasenii* Samuels, Nalim & Geiser, Mycologia 103(6): 1325. 2011. [MB 519852]
 706
- 707 *Fusarium martii* Appel & Wollenw., Arbeiten Kaiserl. Biol. Anst. Land- u. Forstw. 8: 83. 1910. [MB
 708 249096]
 709 ≡ *Neocosmospora martii* (Appel & Wollenw.) Sand.-Den. & Crous, Persoonia 41: 121. 2018. [MB
 710 831187]
 711
- 712 *Fusarium metavorans* Al-Hatmi, S.A. Ahmed & de Hoog, Med. Mycol. 56: S147. 2018. [MB 821742]
 713 ≡ *Neocosmospora metavorans* (Al-Hatmi, S.A. Ahmed & de Hoog) Sand.-Den. & Crous, Persoonia
 714 41: 121. 2018. [MB 823687]

715 Note: Also known as FSSC 6.

716

717 *Fusarium mori* (Sand.-Den. & Crous) O'Donnell, Geiser, Kasson & T. Aoki, Index Fungorum 440: 2. 2020.
718 [IF 557688]

719 ≡ *Neocosmospora mori* Sand.-Den. & Crous, Persoonia 43: 143. 2019. [MB 831188]

720 (= *Fusarium solani* f. *mori* Sawada, Special Publication College of Agriculture, National Taiwan
721 University 8: 222. 1959. Nom. inval., Art. 39.1 [MB 353476])

722 (= *Hypomyces solani* f. *mori* Y. Sakurai & Matuo, Ann. Phytopathol. Soc. Japan 24: 222. 1959. Nom.
723 inval., Art. 39.1 [MB 353542])

724 Note: Also known as *Nectria haematococca* Mating Population III (NhMPIII) and FSSC 17.

725

726 *Fusarium neocosmosporiellum* O'Donnell & Geiser, Phytopathology 103(5): 405. 2013. [MB 800615]

727 ≡ *Neocosmospora vasinfecta* E.F. Sm., Bulletin U.S. Dept. Agri. 17: 45. 1899. [MB 241907]

728 (non *Fusarium vasinfectum* G.F. Atk. 1892. [MB 225413])

729 *Typification* (for *N. vasinfecta*): Lectotype: USA: Pl. V, figs 1-2 as collected on 8 Oct. 1895 (Smith,
730 Bull. U.S. Dept Agric. 17, 1899); Sandoval-Denis et al. 2019)[MBT 387252]; Neotype: USA, SOUTH

731 CAROLINA: Cameron, a dried specimen on cotton (*Gossypium hirsutum*), collected on Oct. 1902,

732 William A. Orton (BPI 630336, Cannon & Hawksworth 1984)[IF 596775]; Epitype: USA, ILLINOIS:

733 southern area, isolated from a cyst of *Heterodera glycines* in a soil sample from soybean field, 6 Apr.

734 1983, Lori M. Carris, CARRIS E-8-8 (BPI 910920, a dried culture of NRRL 22166, Aoki et al. 2020 [IF
735 557666]; Carris and Glawe 1989). Ex-epitype culture NRRL 22166 = ATCC 62199.

736 = *Neocosmospora vasinfecta* E.F. Sm. var. *africana* (Arx) P.F. Cannon & D. Hawksw. Trans. Br. Mycol.
737 Soc. 82(4): 676. 1984. [MB 116939]

738 ≡ *Neocosmospora africana* Arx, Antonie van Leeuwenhoek 21(2): 161. 1955. [MB 301806]

739 Note: Also known as FSSC 8.

740

741 *Fusarium ngaiotongaense* O'Donnell, Geiser, Kasson & T. Aoki, Index Fungorum 440: 3. 2020. [IF 557689]

742 ≡ *Neocosmospora longissima* Sand.-Den. & Crous, Persoonia 43: 141. 2019. [MB 831186] (non

743 *Fusarium longissimum* Sacc. & P. Syd. 1899. [MB 229470])

744 Etymology: *Ngaiotonga* + *-ensis* from the name of its type locality.

745

746 *Fusarium noneumartii* (Sand.-Den. & Crous) O'Donnell, Geiser, Kasson & T. Aoki, Index Fungorum 440: 3.
747 2020. [IF 557690]

748 ≡ *Neocosmospora noneumartii* Sand.-Den. & Crous, Persoonia 43: 145. 2019. [MB 831190]

749 Note: Also known as FSSC 42.

750

751 *Fusarium oblongum* (Sand.-Den. & Crous) O'Donnell, Geiser, Kasson & T. Aoki, Index Fungorum 440: 3.
752 2020. [IF 557691]

753 ≡ *Neocosmospora oblonga* Sand.-Den. & Crous, Persoonia 43: 148. 2019. [MB 831191]

754 Note: Also known as FSSC 29.

755

756 *Fusarium oligoseptatum* T. Aoki, M.T. Kasson, S. Freeman, D.M. Geiser & K. O'Donnell, Fungal
757 Systematics and Evolution 1: 29. 2018. [MB 822305]

758 ≡ *Neocosmospora oligoseptata* (T. Aoki et al.) Sand.-Den. & Crous, Persoonia 43: 149. 2019. [MB
759 831192]

760

- 761 *Fusarium ornamentatum* (M.A.F. Barbosa) O'Donnell, Geiser & T. Aoki, Index Fungorum 440: 3. 2020. [IF
762 557692]
763 ≡ *Neocosmospora ornamentata* M.A.F. Barbosa, Garcia de Orta, Revista da Junta de Investigações
764 do Ultramar (Ministério de Ultramar, Lisboa), Série de Estudos Agrónomicos 13(1): 17. 1965. [MB
765 335130]
- 766
767 *Fusarium paraeumartii* (Sand.-Den. & Crous) O'Donnell, Geiser, Kasson & T. Aoki, Index Fungorum 440:
768 3. 2020. [IF 557693]
769 ≡ *Neocosmospora paraeumartii* Sand.-Den. & Crous, Persoonia 43: 149. 2019. [MB 831193]
770
- 771 *Fusarium parceramosum* (Sand.-Den. & Crous) O'Donnell, Geiser, Kasson & T. Aoki, Index Fungorum 440:
772 3. 2020. [IF 557694] ≡ *Neocosmospora parceramosa* Sand.-Den. & Crous, Persoonia 43: 151. 2019.
773 [MB 831194]
774 Note: Also known as FSSC 18.
775
- 776 *Fusarium perseae* (Sand.-Den. & Guarnaccia) O'Donnell, Geiser & T. Aoki, Index Fungorum 440: 3. 2020.
777 [IF 557695]
778 ≡ *Neocosmospora perseae* Sand.-Den. & Guarnaccia, Fungal Syst. Evol. 1: 136. 2018. [MB 824587]
779
- 780 *Fusarium petroliphilum* (Q.T. Chen & X.H. Fu) Geiser, O'Donnell, D.P.G. Short & N. Zhang, Fungal Genet.
781 Biol. 53: 70. 2013. [MB 802539]
782 ≡ *Fusarium solani* var. *petroliphilum* Q.T. Chen & X.H. Fu, Acta Mycol. Sinica, Suppl.: 330. 1987. [MB
783 127720]
784 ≡ *Neocosmospora petroliphila* (Q.T. Chen & X.H. Fu) Sand.-Den. & Crous, Persoonia 41: 121. 2018.
785 [MB 822902]
786 Note: Also known as *Nectria haematococca* Mating Population V (NhMPV) and FSSC 1
787
- 788 *Fusarium phaseoli* (Burkh.) T. Aoki & O'Donnell, Mycologia 95(4): 671. 2003. [MB 488914]
789 ≡ *Fusarium martii* f. *phaseoli* Burkh., Mem. Cornell U. Agr. Exp. Station 26: 1007. 1919. [MB
790 489076]
791 ≡ *Neocosmospora phaseoli* (Burkh.) L. Lombard & Crous, Stud. Mycol. 80: 227. 2015. [MB 810962]
792
- 793 Also, we recognize the following valid existing species as distinct from *F. phaseoli*:
794 *Fusarium tucumaniae* T. Aoki, O'Donnell, Yosh. Homma & Lattanzi, Mycologia 95(4): 664. 2003. [MB
795 489463]
796 ≡ *Neocosmospora tucumaniae* (T. Aoki et al.) L. Lombard & Crous, Stud. Mycol. 80: 228. 2015. [MB
797 810966]
798 *Fusarium virguliforme* O'Donnell & T. Aoki, Mycologia 95: 667. 2003. [MB 489315]
799 ≡ *Neocosmospora virguliformis* (O'Donnell & T. Aoki) L. Lombard & Crous, Stud. Mycol. 80: 228.
800 2015. [MB 810967]
801 *Fusarium brasiliense* T. Aoki & O'Donnell, Mycoscience 46: 166. 2005. [MB 338753]
802 *Fusarium cuneirostrum* O'Donnell & T. Aoki, Mycoscience 46: 170. 2005. [MB 341392]
803 *Fusarium crassistipitatum* Scandiani et al., Mycoscience 53: 171. 2011. [MB 561257]
804 *Fusarium azukicola* T. Aoki et al., Mycologia 104: 1075. 2012. [MB 563147]
805
- 806 *Fusarium piperis* (F.C. Albuquerque) O'Donnell, Geiser, Kasson & T. Aoki, Index Fungorum 440: 3. 2020. [IF
807 557696]

- 808 ≡ *Neocosmospora piperis* (F.C. Albuquerque) Sand.-Den. & Crous, *Persoonia* 43: 152. 2019. [MB 831195]
 809 ≡ *Fusarium solani* f. *piperis* F.C. Albuquerque, *Circular do Instituto Agronómico do Norte* 5: 19. 1961. [MB
 810 349447]
 811 Note: Also known as FSSC 31.
 812
 813 *Fusarium plagianthi* (Dingley) O'Donnell & Geiser, *Phytopathology* 103(5): 404. 2013. [MB 800613]
 814 ≡ *Nectria plagianthi* Dingley, *Trans. Proc. Royal Soc. New Zealand* 79: 196. 1951. [MB 301780]
 815 ≡ *Neocosmospora plagianthi* (Dingley) L. Lombard & Crous, *Stud. Mycol.* 80: 227. 2015. [MB
 816 810963]
 817
 818 *Fusarium protoensiforme* (Sand.-Den. & Crous) O'Donnell, Geiser, Kasson & T. Aoki, *Index Fungorum*
 819 440: 3. 2020. [IF 557697]
 820 ≡ *Neocosmospora protoensiformis* Sand.-Den. & Crous, *Persoonia* 43: 156. 2019. [MB 831197]
 821 Note: Also known as FSSC 32.
 822
 823 *Fusarium pseudensiforme* Samuels, Nalim & Geiser, *Mycologia* 103(6): 1323. 2011. [MB 519839]
 824 = *Neocosmospora pseudensiformis* Samuels, Nalim & Geiser, *Mycologia* 103(6): 1323. 2011. [MB
 825 519838]
 826 Note: Also known as FSSC 33.
 827
 828 *Fusarium pseudoradicicola* (Sand.-Den. & Crous) O'Donnell, Geiser, Kasson & T. Aoki, *Index Fungorum*
 829 440: 3. 2020. [IF 557698]
 830 ≡ *Neocosmospora pseudoradicicola* Sand.-Den. & Crous, *Persoonia* 43: 157. 2019. [MB 831198]
 831 Note: Also known as FSSC 37.
 832
 833 *Fusarium pseudotonkinense* (Sand.-Den. & Crous) O'Donnell, Geiser, Kasson & T. Aoki, *Index Fungorum*
 834 440: 3. 2020. [IF 557699]
 835 ≡ *Neocosmospora pseudotonkinensis* Sand.-Den. & Crous, *Persoonia* 43: 159. 2019. [MB 831199]
 836
 837 *Fusarium quercinum* O'Donnell, Geiser, Kasson & T. Aoki, *Index Fungorum* 440: 4. 2020. [IF 557700]
 838 ≡ *Neocosmospora quercicola* Sand.-Den. & Crous, *Persoonia* 43: 159. 2019. [MB 831200]
 839 (non *Fusarium quercicola* Oudem. 1902 [MB 204737])
 840 Etymology: *quercinus* (of oak), from the name of the original host plant, *Quercus cerris*.
 841 Note: Also known as FSSC 14.
 842
 843 *Fusarium ramosum* (Batista & H. Maia) O'Donnell, Geiser & T. Aoki, *Index Fungorum* 440: 4. 2020. [IF
 844 557701]
 845 ≡ *Hyaloflorea ramosa* Batista & H. Maia, *Anais Soc. Biol. Pernambuco* 13(1): 155. 1955. [MB
 846 298527]
 847 ≡ *Neocosmospora ramosa* (Batista & H. Maia) L. Lombard & Crous, *Stud. Mycol.* 80: 227. 2015. [MB
 848 810242]
 849
 850 *Fusarium rectiphorus* Samuels, Nalim & Geiser, *Mycologia* 103(6): 1324. 2011. [MB 519851]
 851 = *Neocosmospora rectiphora* Samuels, Nalim & Geiser, *Mycologia* 103(6): 1324. 2011. [MB 519850]
 852 = *Neocosmospora bomiensis* Z.Q. Zeng & W.Y. Zhuang, *Phytotaxa* 319: 177. 2017. [MB 570412]
 853

- 854 *Fusarium regulare* (Sand.-Den. & Crous) O'Donnell, Geiser, Kasson & T. Aoki, Index Fungorum 440: 4.
855 2020. [IF 557702]
856 ≡ *Neocosmospora regularis* Sand.-Den. & Crous, Persoonia 43: 162. 2019. [MB 831201]
857
- 858 *Fusarium rhizophorae* (Dayarathne) O'Donnell, Geiser, Kasson & T. Aoki, Index Fungorum 440: 4. 2020.
859 [IF 557703]
860 ≡ *Neocosmospora rhizophorae* Dayarathne, in Dayarathne, Jones, Maharachchikumbura,
861 Devadatha, Sarma, Khongphinitbunjong, Chomnunti & Hyde, Mycosphere 11(1): 112. 2020. [MB
862 556595]
863
- 864 *Fusarium riograndense* Dallé Rosa, Ramirez-Castrillón, P. Valente, Fuent., van Diepeningen & Goldani, J.
865 Mycol. Med. 28: 33. [MB 814515]
866 ≡ *Neocosmospora riograndensis* (Dallé Rosa et al.) Sand.-Den. & Crous, Persoonia 43: 165. 2019.
867 [MB 831202]
868
- 869 *Fusarium samuelsii* (Sand.-Den. & Crous) O'Donnell, Geiser, Kasson & T. Aoki, Index Fungorum 440: 4.
870 2020. [IF 557704]
871 ≡ *Neocosmospora samuelsii* Sand.-Den. & Crous, Persoonia 43: 165. 2019. [MB 831204]
872
- 873 *Fusarium silvicola* (Sand.-Den. & Crous) O'Donnell, Geiser, Kasson & T. Aoki, Index Fungorum 440: 4.
874 2020. [IF 557705]
875 ≡ *Neocosmospora silvicola* Sand.-Den. & Crous, Persoonia 43: 167. 2019. [MB 831205]
876 = *Fusarium solani* f. *robiniae* Matuo & Y. Sakurai, Ann. Phytopathol. Soc. Japan 30: 35. 1965. [MB
877 348448](non *Fusarium robiniae* Pass. 1891. [MB 203747])
878 = *Hypomyces solani* f. *robiniae* Matuo & Y. Sakurai, Ann. Phytopathol. Soc. Japan 30: 35. 1965. [MB
879 349586]
880 Note: Also known as FSSC 13.
881
- 882 ≡ *Nectria solani* f. *robiniae* (Matuo & Y. Sakurai) G.R.W. Arnold, Z. Pilzk. 37(1-4): 193. 1972. [MB
883 348527]
884 Note: Also known as *Nectria haematococca* Mating Population VII (NhMPVII)
885
- 886 *Fusarium solani* (Mart.) Sacc., Michelia 2(7): 296. 1881. [MB 190352]
887 ≡ *Fusisporium solani* Mart., Die Kartoffel-Epidemie der letzten Jahre oder die Stockfäule und Räude
888 der Kartoffeln: 20. 1842. [MB 194746]
889 ≡ *Neocosmospora solani* (Mart.) L. Lombard & Crous, Stud. Mycol. 80: 228. 2015. [MB 810964]
890 = *Neocosmospora rubicola* L. Lombard & Crous, Stud. Mycol. 80: 227. 2015. [MB 810243]
891 Note: Also known as FSSC 5.
892
- 893 *Fusarium solani-melongenae* O'Donnell, Geiser, Kasson & T. Aoki, Index Fungorum 440: 4. 2020. [IF
894 557706]
895 ≡ *Neocosmospora ipomoeae* (Halst.) L. Lombard & Crous, Stud. Mycol. 80: 227. 2015. [MB 810960]
896 ≡ *Nectria ipomoeae* Halst., Report of the New Jersey State Agricultural Experimental Station 12: 281
897 (1891) [MB 210931] (non *Fusarium ipomoeae* M.M. Wang, Qian Chen & L. Cai 2019 [MB 829538],
898 non *Fusarium batatas* Wollenw. 1914 [MB 175963])
899 ≡ *Hypomyces ipomoeae* (Halst.) Wollenw., Phytopathology 3(1): 34. 1913. [MB 212639]

- 900 ≡ *Haematonectria ipomoeae* (Halst.) Samuels & Nirenberg, in Rossman, Samuels, Rogerson &
 901 Lowen, Stud. Mycol. 42: 136. 1999. [MB 460446]
 902 Etymology: From the correct name of its original plant host, *Solanum melongena* (Halstead 2015),
 903 represented by its holotype, BPI 552416 (Sandoval-Denis et al. 2019).
 904
- 905 *Fusarium spathulatum* (Sand.-Den. & Crous) O'Donnell, Geiser, Kasson & T. Aoki, Index Fungorum 440:
 906 4. 2020. [IF 557707]
 907 ≡ *Neocosmospora spathulata* Sand.-Den. & Crous, Persoonia 43: 171. 2019. [MB 831206]
 908 Note: Also known as FSSC 26.
 909
- 910 *Fusarium sphaerosporum* Q.T. Chen & X.H. Fu, Acta Mycol. Sin., Suppl. 1: 331. 1987 [MB 127721]
 911 ≡ *Neocosmospora sphaerospora* (Q.T. Chen & X.H. Fu) Sand.-Den. & Crous, Persoonia 43: 173. 2019.
 912 [MB 832096]
 913
- 914 *Fusarium spinulosum* (Pfenning) O'Donnell, Geiser, Kasson & T. Aoki, Index Fungorum 440: 4. 2020. [IF
 915 557708]
 916 ≡ *Neocosmospora spinulosa* Pfenning, Sydowia 47: 66. 1995. [MB 413567]
 917
- 918 *Fusarium stercicola* Šišić, Al-Hatmi, Baćanović-Šišić, S.A. Ahmed & Finckh, Antonie van Leeuwenhoek
 919 111: 1793. 2018. [MB 823581]
 920 ≡ *Neocosmospora stercicola* (Šišić et al.) Sand.-Den. & Crous, Persoonia 43: 173. 2019. [MB 831207]
 921 = *Fusarium witzenhausenense* Šišić et al., Antonie van Leeuwenhoek 111: 1795. 2018. [MB 823582]
 922
- 923 *Fusarium suttonianum* (Sand.-Den. & Crous) O'Donnell, Geiser & T. Aoki, Index Fungorum 440: 4. 2020.
 924 [IF 557709]
 925 ≡ *Neocosmospora suttoniana* Sand.-Den. & Crous, Persoonia 41: 123. 2018. [MB 822903]
 926 Note: Also known as FSSC 20.
 927
- 928 *Fusarium tenuicristatum* (S. Ueda & Udagawa) O'Donnell, Geiser & T. Aoki, Index Fungorum 440: 4.
 929 2020. [IF 557710]
 930 ≡ *Neocosmospora tenuicristata* S. Ueda & Udagawa, Mycotaxon 16(2): 387. 1983. [MB 109113]
 931 = *Neocosmospora boninensis* Udagawa, Y. Horie & P.F. Cannon, Sydowia 41: 350. 1989. [MB
 932 125987]
 933
- 934 *Fusarium theobromae* Appel & Strunk, Centralbl. Bakteriell. Parasitenk., 1. Abth. 13: 685. 1904. [MB
 935 235605]
 936 ≡ *Neocosmospora theobromae* (Appel & Strunk) Sand.-Den. & Crous, Persoonia 43: 174. 2019. [MB
 937 831208]
 938
- 939 *Fusarium tonkinense* (Bugnic.) O'Donnell, Geiser & T. Aoki, Index Fungorum 440: 4. 2020. [IF 557711]
 940 ≡ *Cylindrocarpon tonkinense* Bugnic., Encyclopédie Mycologique 11: 181. 1939. [MB 255134]
 941 ≡ *Neocosmospora tonkinensis* (Bugnic.) Sand.-Den. & Crous, Persoonia 41: 126. 2018. [MB 822904]
 942 ≡ *Fusarium ershadii* Papizadeh, van Diepeningen & Zamanizadeh, Europ. J. Plant Pathol. 151: 693.
 943 2018. (nom. illegit. as a superfluous name, Art 52.1). [MB 817602]
 944 Note: Also known as FSSC 9.
 945
- 946 *Fusarium vanettenii* O'Donnell, Geiser, Kasson & T. Aoki, Index Fungorum 440: 5. 2020. [IF 557712]

- 947 ≡ *Neocosmospora pisi* (F.R. Jones) Sand.-Den. & Crous, *Persoonia* 43: 143. 2019. [MB 831189]
 948 ≡ *Fusarium martii* var. *psii* F.R. Jones, *J. Agric. Res.* 26: 459. 1923. [MB 270614].
 949 ≡ *Fusarium solani* f. *psii* (F.R. Jones) W.C. Snyder & H.N. Hansen, *Amer. J. Bot.* 28: 740. 1941. [MB
 950 351714]
 951 (≡ *Fusarium pisi* (F.R. Jones) A. Šišić et al., *Sci. Rep.* 8: 2. 2018. Nom. inval., Art. 42.1 [MB 824719])
 952 Note: Also known as *Nectria haematococca* Mating Population VI (NhMPVI) and FSSC 11.
 953 Etymology: In honor of the late Hans D. Van Etten, whose laboratory conducted extensive studies on this
 954 species, making the first connection between plant pathogenicity and the fungal accessory genome.
 955
 956 *Fusarium venezuelense* O'Donnell, Geiser, Kasson & T. Aoki, *Index Fungorum* 440: 5. 2020. [IF 557713]
 957 ≡ *Neocosmospora robusta* Sand.-Den. & Crous, *Persoonia* 43: 165. 2019. [MB 831203]
 958 (non *Fusarium robustum* Gerlach 1977 [MB 314220])
 959 Etymology: *Venezuela* + *-ensis* from the name of its type locality.
 960
 961 *Fusarium waltegershamii* O'Donnell, Geiser & T. Aoki, *Index Fungorum* 440: 5. 2020. [IF 557714]
 962 ≡ *Neocosmospora gamsii* Sand.-Den. & Crous, *Persoonia* 41: 116. 2018. [MB 822899] (non *Fusarium*
 963 *gamsii* Torbati, Arzanlou, Sand.-Den. 2019 [MB 825228])
 964 Etymology: In honor of the late Dr. Walter Gams.
 965 Note: Also known as FSSC 7.
 966
 967 *Fusarium yamamotoi* O'Donnell, Geiser, Kasson & T. Aoki, *Index Fungorum* 440: 5. 2020. [IF 557715]
 968 ≡ *Nectria elegans* W. Yamam. & Maeda, *Sci. Rep. Hyogo Univ. Agric.* 3: 15. 1957. [MB 301759] (non
 969 *Fusarium elegans* Appel & Wollenw. 1910 [MB 451612])
 970 ≡ *Neocosmospora elegans* (W. Yamam. & Maeda) Sand.-Den. & Crous, *Persoonia* 43: 127. 2019.
 971 [MB 831226]
 972 (≡ *Fusarium elegans* W. Yamam. & Maeda, *Trans. Mycol. Soc. Japan* 3: 115. 1962. Nom. illegit., Art
 973 53.1 [MB 330986])
 974 (= *Fusarium solani* f. *xanthoxyli* Y. Sakurai & Matuo, *Ann. Phytopathol. Soc. Japan* 26: 117. 1961.
 975 Nom. inval., Art. 39.1 [MB 350973])
 976 (= *Hypomyces solani* f. *xanthoxyli* Y. Sakurai & Matuo, *Ann. Phytopathol. Soc. Japan* 26: 117. 1961.
 977 Nom. inval., Art. 39.1 [MB 350974])
 978 Note: Also known as *Nectria haematococca* Mating Population IV (NhMPIV) and FSSC 22.
 979 Etymology: in honor of the late Dr. Wataro Yamamoto who originally found *Nectria elegans* and studied
 980 trunk blight of *Zanthoxylum piperitum*.
 981

LITERATURE CITED

- 982
 983
 984 Aoki, T., Geiser, D. M., Kasson, M. T. and O'Donnell, K. 2020. Nomenclatural novelties. *Index Fungorum*
 985 440:1-5.
 986
 987 Aoki, T., O'Donnell, K., and Scandiani, M. M. 2005. Sudden death syndrome of soybean in South America
 988 is caused by four species of *Fusarium*: *Fusarium brasiliense* sp. nov., *F. cuneiorostrum* sp. nov., *F.*
 989 *tucumaniae* and *F. viruliforme*. *Mycoscience* 46:162-183.

- 990
- 991 Aoki, T., Tanaka, F., Suga, H., Hyakumachi, M., Scandiani, M. M., and O'Donnell, K. 2012. *Fusarium*
- 992 *azukicola* sp. nov., an exotic azuki bean root-rot pathogen in Hokkaido, Japan. *Mycologia* 104:1068-
- 993 1084.
- 994
- 995 Bilai, V. I. 1955. *Fusarii*. Izd. Akad. Nauk. Ukrain. SSR, Kiev.
- 996
- 997 Booth, C. 1971. The Genus *Fusarium*. Commonwealth Mycological Institute, Surrey, England.
- 998
- 999 Booth, C. 1978. Do you believe in genera? *Trans. Br. Mycol. Soc.* 71:1-9.
- 1000
- 1001 Brown, D. W., and Proctor R. H. 2016. Insights into natural products biosynthesis from analysis of 490
- 1002 polyketide synthases from *Fusarium*. *Fungal Genet. Biol.* 89:37-51.
- 1003
- 1004 Brown, D. W., Villani, A., Susca, A., Moretti, A., Hao, G., Kim, H.-S., Proctor, R. H., and McCormick, S. P.
- 1005 2020. Gain and loss of a transcription factor that regulates late trichothecene biosynthetic pathway
- 1006 genes in *Fusarium*. *Fungal Genet. Biol.* 136:103317.
- 1007
- 1008 Busman, M., Desjardins, A. E., and Proctor, R. H. 2012. Analysis of fumonisin contamination and the
- 1009 presence of *Fusarium* in wheat with kernel black point disease in the United States. *Food Addit.*
- 1010 *Contam. Part A* 29:1092-1100.
- 1011
- 1012 Chernomor, O., von Haeseler, A., and Minh, B. Q. 2016. Terrace aware data structure for phylogenomic
- 1013 inference from supermatrices. *Syst. Biol.* 65:997-1008.
- 1014
- 1015 Coleman, J. J., Rounsley, S. D., Rodriguez-Carres, M., Kuo, A., Wasmann, C. C., Grimwood, J., Schmutz, J.,
- 1016 Taga, M., White, G. J., Zhou, S., Schwartz, D. C., Freitag, M., Ma, L.-j., Danchin, E. G. J., Henrissat, B.,
- 1017 Coutinho, P. M., Nelson, D. R., Straney, D., Napoli, C. A., Barker, B. M., Gribskov, M., Rep, M., Kroken,
- 1018 S., Molnár, I., Rensing, C., Kennell, J. C., Zamora, J., Farman, M. L., Selker, E. U., Salamov, A., Shapiro,
- 1019 H., Pangilinan, J., Lindquist, E., Lamers, C., Grigoriev, I. V., Geiser, D. M., Covert, S. F., Temporini, E.,
- 1020 and VanEtten, H. D. 2009. The genome of *Nectria haematococca*: Contribution of supernumerary
- 1021 chromosomes to gene expansion. *PLoS Genet.* 5:e1000618.

- 1022
- 1023 Domsch, K. H., Gams, W., and Anderson, T.-H. 1980. *Compendium of Soil Fungi*. Academic Press.
- 1024
- 1025 Edgar, R. C. 2004. MUSCLE: multiple sequence alignment with high accuracy and high throughput. *Nucleic*
- 1026 *Acids Res.* 32:1792-1797.
- 1027
- 1028 Farris, J. S. 1990. Haeckel, history, and Hull. *Syst. Zool.* 39:81-88.
- 1029
- 1030 Felsenstein, J. 1978. Cases in which parsimony or compatibility methods will be positively misleading.
- 1031 *Syst. Biol.* 27:401-410.
- 1032
- 1033 Floudas, D., Binder, M., Riley, R., Barry, K., Blanchette, R. A., Henrissat, B., Martinez, A. T., Otilar, R.,
- 1034 Spatafora, J. W., Yadav, J. S., Aerts, A., Benoit, I., Boyd, A., Carlson, A., Copeland, A., Coutinho, P. M., de
- 1035 Vries, R. P., Ferreira, P., Findley, K., Foster, B., Gaskell, J., Glotzer, D., Gorecki, P., Heitman, J., Hesse, C.,
- 1036 Hori, C., Igarashi, K., Jurgens, J. A., Kallen, N., Kersten, P., Kohler, A., Kues, U., Kumar, T. K. A., Kuo, A.,
- 1037 LaButti, K., Larrondo, L. F., Lindquist, E., Ling, A., Lombard, V., Lucas, S., Lundell, T., Martin, R., McLaughlin,
- 1038 D. J., Morgenstern, I., Morin, E., Murat, C., Nagy, L. G., Nolan, M., Ohm, R. A., Patyshakuliyeva, A., Rokas,
- 1039 A., Ruiz-Duenas, F. J., Sabat, G., Salamov, A., Samejima, M., Schmutz, J., Slot, J. C., John, F. S., Stenlid, J.,
- 1040 Sun, H., Sun, S., Syed, K., Tsang, A., Wiebenga, A., Young, D., Pisabarro, A., Eastwood, D. C., Martin, F.,
- 1041 Cullen, D., Grigoriev, I. V., and Hibbett, D. S. 2012. The Paleozoic origin of enzymatic lignin decomposition
- 1042 reconstructed from 31 fungal genomes. *Science* 336:1715-1719.
- 1043
- 1044 Gams, W. 1971. *Cephalosporium*-artige Schimmelpilze (Hyphomyces). Gustav Fischer, Stuttgart,
- 1045 Germany.
- 1046
- 1047 Gams, W., and Nirenberg, H. I. 1989. A contribution to the generic definition of *Fusarium*. *Mycotaxon*
- 1048 35:407-416.
- 1049
- 1050 Geiser, D. M., Aoki, T., Bacon, C. W., Baker, S. E., Bhattacharyya, M. K., Brandt, M. E., Brown, D. W.,
- 1051 Burgess, L. W., Chulze, S., Coleman, J. J., Correll, J. C., Covert, S. F., Crous, P. W., Cuomo, C. A., De
- 1052 Hoog, G. S., Di Pietro, A., Elmer, W. H., Epstein, L., Frandsen, R. J. N., Freeman, S., Gagkaeva, T.,
- 1053 Glenn, A. E., Gordon, T. R., Gregory, N. F., Hammond-Kosack, K. E., Hanson, L. E., del Mar Jiménez-

- 1054 Gasco, M., Kang, S., Kistler, H. C., Kuldau, G. A., Leslie, J. F., Logrieco, A., Lu, G., Lysøe, E., Ma, L.-J.,
1055 McCormick, S. P., Migheli, Q., Moretti, A., Munaut, F., O'Donnell, K., Pfenning, L., Ploetz, R. C.,
1056 Proctor, R. H., Rehner, S. A., Robert, V. A. R. G., Rooney, A. P., bin Salleh, B., Scandiani, M. M.,
1057 Scauflaire, J., Short, D. P. G., Steenkamp, E., Suga, H., Summerell, B. A., Sutton, D. A., Thrane, U., Trail,
1058 F., Van Diepeningen, A., Van Etten, H. D., Viljoen, A., Waalwijk C., Ward, T. J., Wingfield, M. J., Xu, J.-
1059 R., Yang, X.-B., Yli-Mattila, T., and Zhang, N. 2013. One fungus, one name: Defining the genus
1060 *Fusarium* in a scientifically robust way that preserves longstanding use. *Phytopathology* 103:400-408.
1061
- 1062 Gerlach, W., and Nirenberg, H. I. 1982. The genus *Fusarium* – A pictorial atlas. *Mitt. Biol. Bundesanst. Land-*
1063 *Forstwirtschaft.* 209:1-406.
1064
- 1065 Gräfenhan, T., Schroers, H.-J., Nirenberg, H. I., and Seifert, K. A. 2011. An overview of the taxonomy,
1066 phylogeny, and typification of nectriaceous fungi in *Cosmospora*, *Acremonium*, *Fusarium*, *Stibella*,
1067 and *Volutella*. *Stud. Mycol.* 68:79-113.
1068
- 1069 Joffe, A. Z. 1974. A modern system of *Fusarium* taxonomy. *Mycopathol. Mycol. Appl.* 53:201-228.
1070
- 1071 Kalyaanamoorthy, S., Minh, B. Q., Wong, T. K. F., von Haeseler, A., and Jermini, L. S. 2017. ModelFinder:
1072 fast model selection for accurate phylogenetic estimates. *Nat. Meth.* 14:587-589.
1073
- 1074 Kasson, M. T., O'Donnell, K., Rooney, A. P., Sink, S., Ploetz, R. C., Ploetz, J. N., Konkol, J. L., Carrillo, D.,
1075 Freeman, S., Mendel, Z., Smith, J. A., Black, A. W., Hulcr, J., Bateman, C., Stefkova, K., Campbell, P. R.,
1076 Geering, A. D. W., Dann, E. K., Eskalen, A., Mohotti, K., Short, D. P. G., Aoki, T., Fenstermacher, K. A.,
1077 Davis, D. D., and Geiser, D. M. 2013. An inordinate fondness for *Fusarium*: Phylogenetic diversity of
1078 fusaria cultivated by ambrosia beetles in the genus *Euwallacea* on avocado and other plant hosts.
1079 *Fungal Genet. Biol.* 56:147-157.
1080
- 1081 Kim, H.-S., Lohmar, J. M., Busman, M., Brown, D. W., Naumann, T. A., Divon, H. H., Uhlig, S., and Proctor,
1082 R. H. 2020. *BMC Genomics* <https://doi.org/10.1186/s12864-020-06896-1>
1083
- 1084 Kobert, K., Salichos, L., Rokas, A., and Stamatakis, A. 2016. Computing the Internode Certainty and related
1085 measures from gene trees. *Mol. Biol. Evol.* 33:1606-1617.

- 1086
- 1087
- 1088 Kocsubé, S., Perrone, G., Magistá, D., Houbraken, J., Varga, J., Szigeti, G., Hubka, V., Hong, S-B., Frisvad, J.
- 1089 C., and Samson, R. A. 2016. *Aspergillus* is monophyletic: Evidence from multiple gene phylogenies
- 1090 and extrolites profiles. *Stud. Mycol.* 85:199-213.
- 1091
- 1092 Kumar, S., Stecher, G., and Tamura, K. 2016. MEGA7 : Molecular Evolutionary Genetics Analysis version
- 1093 7.0 for bigger datasets. *Mol. Biol. Evol.* 33:1870-1874.
- 1094
- 1095 Laraba, I., Keddad, A., Boureghda, H., Abdallah, N., Vaughan, M. M., Proctor, R. H., Busman, M.,
- 1096 and O'Donnell, K. 2018. *Fusarium algeriense*, sp. nov., a novel toxigenic crown rot pathogen of durum
- 1097 wheat from Algeria is nested in the *Fusarium burgessii* species complex. *Mycologia* 109:935-950.
- 1098
- 1099 Laraba, I., Kim, H.-S., Proctor, R. H., Busman, M., O'Donnell, K., Felker, F. C., Aime, M. C., Koch, R. A., and
- 1100 Wurdack, K. J. 2020a. *Fusarium xyrophilum*, sp. nov., a member of the *Fusarium fujikuroi* species
- 1101 complex recovered from pseudoflowers on yellow-eyed grass (*Xyris* spp.) from Guyana. *Mycologia*
- 1102 112:39-51.
- 1103
- 1104 Laraba, I., McCormick, S. P., Vaughan, M. M., Proctor, R. H., Busman, M., Appell, M., O'Donnell, K.,
- 1105 Felker, F. C., Aime, M. C., and Wurdack, K. J. 2020b. Pseudoflowers produced by *Fusarium xyrophilum*
- 1106 on yellow-eyed grass (*Xyris* spp.) in Guyana : A novel floral mimicry system ? *Fungal. Genet. Biol.*
- 1107 144:103466.
- 1108
- 1109 Laurence, M. H., Summerell, B. A., Burgess, L. W., and Liew, E. C. Y. 2011. *Fusarium burgessii* sp. nov.
- 1110 Representing a novel lineage in the genus *Fusarium*. *Fungal Divers.* 49:101-112.
- 1111
- 1112 Laurence, M. H., Walsh, J. L., Shuttleworth, L.A., Robinson, D. M., Johansen, R. M., Petrovi, T., Vu, T. T.
- 1113 H., Burgess, L. W., Summerell, B. A., and Liew, E. C. Y. 2016. Six novel species of *Fusarium* from
- 1114 natural ecosystems in Australia. *Fungal Divers.* 77:349-366.
- 1115
- 1116 Leslie, J. F., and Summerell, B. A. 2006a. The *Fusarium* Laboratory Manual. Blackwell Publishing, Ames,
- 1117 IA.

- 1118
- 1119 Leslie, J. F., and Summerell, B. A. 2006b. *Fusarium* laboratory workshops – A recent history. *Mycotoxin*
- 1120 Res. 22:73-74.
- 1121
- 1122 Lombard, L., van der Merwe, N. A., Groenewald, J. Z., and Crous, P. W. 2015. Generic concepts in
- 1123 *Nectriaceae*. *Stud. Mycol.* 80:189-245.
- 1124
- 1125 Ma, L.-J., van Der Does, H. C., Borkovich, K. A., Coleman, J. J., Daboussi, M.-J., Di Pietro, A., Dufresne, M.,
- 1126 Freitag, M., Grabherr, M., Henrissat, B., Houterman, P. M., Kang, S., Shim, W.-B., Woloshuk, C., Xie, X.,
- 1127 Xu, J.-R., Antoniw, J., Baker, S. E., Bluhm, B. H., Breakspear, A., Brown, D. W., Butchko, R. A. E.,
- 1128 Chapmen, S., Coulson, R., Coutinho, P. M., Danchin, E. G. J., Diener, A., Gale, L. R., Gardiner, D. M.,
- 1129 Goff, S., Hammond-Kosack, K. E., Hilburn, K., Hua-Van, A., Jonkers, W., Kazan, K., Kodira, C. D.,
- 1130 Koehrsen, M., Kumar, L., Lee, Y.-H., Li, L., Manners, J. M., Miranda-Saavedra, D., Mukherjee, M., Park,
- 1131 G., Park, J., Park, S.-Y., Proctor, R. H., Regev, A., Ruiz-Roldan, M. C., Sain, D., Sakthikumar, S., Sykes, S.,
- 1132 Schwartz, D. C., Turgeon, B. G., Wapainski, I., Yoder, O., Young, S., Zeng, Q., Zhou, S., Galagan, J.,
- 1133 Cuomo, C. A., Kistler, H. C., and Rep, M. 2010. Comparative genomics reveals mobile pathogenicity
- 1134 chromosomes in *Fusarium*. *Nature* 464:367-373.
- 1135
- 1136 Matuo, T. 1972. Taxonomic studies of phytopathogenic fusaria in Japan. *Rev. Plant Protec. Res.* 5:34-45.
- 1137
- 1138 Minh, B. Q., Hahn, M. W., and Lanfear, R. L. 2020a. New methods to calculate concordance factors for
- 1139 phylogenomic datasets. *Mol. Biol. Evol.* 37:2727-2733.
- 1140
- 1141 Minh, B. Q., Schmidt, H. A., Chernomor, O., Schrempf, D., Woodhams, M. D., von Haeseler, A., and
- 1142 Lanfear, R. 2020b. IQ-TREE 2: new models and efficient methods for phylogenetic inference in the
- 1143 genomic era. *Mol. Biol. Evol.* 37:1530-1534.
- 1144
- 1145 Nalim, F. A., Samuels, G. J., Wijesundera, R. L., and Geiser, D. M. 2011. New species from the *Fusarium*
- 1146 *solani* species complex derived from perithecia and soil in the Old World tropics. *Mycologia*
- 1147 103:1302-1330.
- 1148

- 1149 Nelson, P. E., Toussoun, T. A., and Burgess, L. W. 1987. Characterization of *Fusarium beomiforme* sp.
1150 nov. Mycologia 79:884-889.
1151
- 1152 Nelson, P. E., Toussoun, T. A., and Marasas, W. F. O. 1983. *Fusarium* Species: An Illustrated MI for
1153 Identification. University Park, Pennsylvania: Pennsylvania State University Press.
1154
- 1155 Nguyen, L.-T., Schmidt, H. A., von Haeseler, A., and Minh, B. Q. 2015. IQ-TREE: A fast and effective
1156 stochastic algorithm for estimating maximum-likelihood phylogenies. Mol. Biol. Evol. 32:268-274.
1157
- 1158 O'Donnell, K. 2000. Molecular phylogeny of the *Nectria haematococca-Fusarium solani* species complex.
1159 Mycologia 92:919-938.
1160
- 1161 O'Donnell, K., Al-Hatmi, A. M. S., Aoki, T., Brankovics, B., Cano-Lira, J. F., Coleman, J. J., de Hoog, G. S., Di
1162 Pietro, A., Frandsen, R. J. N., Geiser, D. M., Gibas, C. F. C., Guarro, J., Kim, H.-S., Kistler, H. C., Laraba,
1163 I., Leslie, J. F., López-Berges, M. S., Lysøe, E., Meis, J. F., Monod, M., Proctor, R. H., Rep, M., Ruiz-
1164 Roldán, C., Šišić, A., Stajich, J. E., Steenkamp, E. T., Summerell, B. A., van der Lee, T. A. J., van
1165 Diepeningen, A. D., Verweij, P. E., Waalwijk, C., Ward, T. J., Wickes, B. L., Wiederhold, N. P., Wingfield,
1166 M. J., Zhang, N., and Zhang, S. X. 2020. No to *Neocosmospora*: phylogenomic and practical reasons
1167 for continued inclusion of the *Fusarium solani* species complex in the genus *Fusarium*. mSphere
1168 5:e00810-20. <https://doi.org/10.1128/mSphere.00810-20>.
1169
- 1170 O'Donnell, K., Rooney, A. P., Proctor, R. H., Brown, D. W., McCormick, S. P., Ward, T. J., Frandsen, R. J. N.,
1171 Lysøe, E., Rehner, S. A., Aoki, T., Robert, V. A. R. G., Crous, P. W., Groenewald, J. Z., Kang, S., and
1172 Geiser, D. M. 2013. Phylogenetic analyses of *RPB1* and *RPB2* support a middle Cretaceous origin for a
1173 clade comprising all agriculturally and medically important fusaria. Fungal Genet. Biol. 52:20-31.
1174
- 1175 O'Donnell, K., Sink, S., Libeskind-Hadas, R., Hulcr, J., Kasson, M. T., Ploetz, R. C., Konkol, J. L., Ploetz, J. N.,
1176 Carrillo, D., Campbell, A., Duncan, R. E., Liyanage, P. N. H., Eskalen, A., Na, F., Geiser, D. M., Bateman,
1177 C., Freeman, S., Mendel, Z., Sharon, M., Aoki, T., Cossé, A. A., and Rooney, A. P. 2015. Discordant
1178 phylogenies suggest repeated host shifts in the *Fusarium-Euwallacea* ambrosia beetle mutualism.
1179 Fungal Genet. Biol. 82:277-290.
1180

- 1181 O'Donnell, K., Sutton, D. A., Fothergill, A., McCarthy, D., Rinaldi, M. G., Brandt, M. E., Zhang, N., and
1182 Geiser, D. M. 2008. Molecular phylogenetic diversity, multilocus haplotype nomenclature, and in
1183 vitro antifungal resistance within the *Fusarium solani* species complex. *J. Clin. Microbiol.* 46:2477-
1184 2490.
- 1185
- 1186 Proctor, R. H., Desjardins, A. E., and Moretti, A. 2010. Biological and chemical complexity of *Fusarium*
1187 *proliferatum*. In: Strange, R. N. and Gullino, M. L., eds. *The Role of Plant Pathology in Food Safety and*
1188 *Food Security*. Dordrecht: Springer. p. 97-111.
- 1189
- 1190 Proctor, R. H., McCormick, S. P., Alexander, N. J., and Desjardins, A. E. 2009. Evidence that a secondary
1191 metabolic biosynthetic gene cluster has grown by gene relocation during evolution of the filamentous
1192 fungus *Fusarium*. *Mol. Microbiol.* 74:1128-1142.
- 1193
- 1194 Proctor, R. H., McCormick, S. P., Kim, H.-S., Cardoza, R. E., Stanley, A. M., Lindo, L., Kelly, A., Brown, D.
1195 W., Lee, T., Vaughan, M. M., Alexander, N. J., Busman, M., and Gutiérrez, S. 2018. Evolution of
1196 structural diversity of trichothecenes, a family of toxins produced by plant pathogenic and
1197 entomopathogenic fungi. *PLoS Pathog.* 14:e1006946.
- 1198
- 1199 Proctor, R. H., Van Hove, F., Susca, A., Stea, G., Busman, M., van der Lee, T., Waalwijk, C., Moretti, A.,
1200 and Ward, T. J. 2013. Birth, death and horizontal transfer of the fumonisin biosynthetic gene cluster
1201 during the evolutionary diversification of *Fusarium*. *Mol. Microbiol.* 90:290-306.
- 1202
- 1203 Raeder, U., and Broda P. 1985. Rapid preparation of DNA from filamentous fungi. *Lett. Appl. Microbiol.*
1204 1:17-20.
- 1205
- 1206 Raillo, A. I. 1950. *Fungi of the genus Fusarium*. Government Publishers of Agricultural Literature,
1207 Moscow.
- 1208
- 1209 Ronquist, F., Teslenko, M., van der Mark, P., Ayres, D., Darling, A., Höhna, S., Larget, B., Liu, L., Suchard,
1210 M. A., and Huelsenbeck, J. P. 2012. MrBayes 3.2: efficient Bayesian phylogenetic inference and model
1211 choice across a large model space. *Syst. Biol.* 61:539-542.
- 1212

- 1213 Rossman, A. Y., Seifert, K. A., Samuels, G. J., Minnis, A. M., Schroers, H.-J., Lombard, L., Crous, P. W.,
1214 Pöldmaa, K., Cannon, P. F., Summerbell, R. C., Geiser, D. M., Zhuang, W.-y., Hirooka, Y., Herrera, C.,
1215 Salgado-Salazar, C., and Chaverri, P. 2013. Genera in Bionectriaceae, Hypocreaceae, and Nectriaceae
1216 (Hypocreales) proposed for acceptance or rejection. *IMA Fungus* 4:41-51.
1217
- 1218 Salichos, L., and Rokas, A. 2013. Inferring ancient divergences requires genes with strong phylogenetic
1219 signals. *Nature* 497:327-331.
1220
- 1221 Salichos, L., Stamakis, A., and Rokas, A. 2014. Novel information theory-based measures for quantifying
1222 incongruence among phylogenetic trees. *Mol. Biol. Evol.* 31:1261-1271.
1223
- 1224 Samson, R. A., Visagie, C. M., Houbroken, J., Hong, S.-B., Hubka, V., Klaassen, C. H. W., Perrone, G.,
1225 Seifert, K. A., Susca, A., Tanney, J. B., Varga, J., Kocsubé, S., Szigeti, G., Yaguchi, T., and Frisvad, J. C.
1226 2014. Phylogeny, identification and nomenclature of the genus *Aspergillus*. *Stud. Mycol.* 78:141-173.
1227
- 1228 Samuels, G. J., and Hallett, I. C. 1983. *Microdochium stoveri* and *Monographella stoveri*, new
1229 combinations for *Fusarium stoveri* and *Micronectriella stoveri*. *Trans. Br. Mycol. Soc.* 81:473-483.
1230
- 1231 Sandoval-Denis, M., and Crous, P. W. 2018. Removing chaos from confusion: assigning names to
1232 common human and animal pathogens in *Neocosmospora*. *Persoonia* 41:109-129.
1233
- 1234 Sandoval-Denis, M., Guarnaccia, V., Polizzi, G., and Crous, P. W. 2018. Symptomatic *Citrus* trees reveal a
1235 new pathogenic lineage in *Fusarium* and two new *Neocosmospora* species. *Persoonia* 40:1-25.
1236
- 1237 Sandoval-Denis, M., Lombard, L., and Crous, P. W. 2019. Back to the roots: a reappraisal of
1238 *Neocosmospora*. *Persoonia* 43:90-185.
1239
- 1240 Sarver, B. A. J., Ward, T. J., Gale, L. R., Broz, K., Kistler, H. C., Aoki, T., Nicholson, P., Carter, J., 'nd
1241 O'Donnell, K. 2011. Novel *Fusarium* head blight pathogens from Nepal and Louisiana revealed by
1242 multilocus genealogical concordance. *Fungal Genet. Biol.* 48:1096-1107.
1243

- 1244 Schroers, H.-J., Gräfenhan, T., Nirenberg, H. I., and Seifert, K. A. 2011. A revision of *Cyanonectria* and
1245 *Geejayessia* gen. nov., and related species with *Fusarium*-like anamorphs. *Stud. Mycol.* 68:115-138.
1246
- 1247 Short, D. P. G., O'Donnell, K., Thrane, U., Nielsen, K. F., Zhang, N., Juba, J. H., and Geiser, D. M. 2013.
1248 Phylogenetic relationships among members of the *Fusarium solani* species complex in human
1249 infections and the descriptions of *F. keratoplasticum* sp. nov. and *F. petroliphilum* stat. nov. *Fungal*
1250 *Genet. Biol.* 53:59-70.
1251
- 1252 Smith, E. F. 1899. Wilt disease of cotton, watermelon, and cowpea (*Neocosmospora* nov. gen.). *USDA*
1253 *Bull.* 17:1-54.
1254
- 1255 Snyder, W. C., and Hansen, H. N. 1941. The species concept in *Fusarium* with reference to Section
1256 *Martiella*. *Am. J. Bot.* 28:738-742.
1257
- 1258 Solovyev, V., Kosarev, P., Seledsov, I., and Vorobyev, D. 2006. Automatic annotation of eukaryotic genes,
1259 pseudogenes and promoters. *Genome Biol.* 7, Suppl 1:10.1-10.12.
1260
- 1261 Stamakis, A. 2014. RAxML version 8: a tool for phylogenetic analysis and post-analysis of large
1262 phylogenies. *Bioinformatics* 30:1312-1313. doi: 10.1093/bioinformatics/btu033
1263
- 1264 Stanke, M., Keller, O., Gunduz, I., Hayes, A., Waack, S., and Morgenstern, B. 2006. AUGUSTUS: *ab initio*
1265 prediction of alternative transcripts. *Nucleic Acids Res.* 34(Web Server issue):W435-439.
1266
- 1267 Steenwyk, J. L., Shen, X.-X., Lind, A. L., Goldman, G. H., and Rokas, A. 2019. A robust phylogenomic time
1268 tree for biotechnologically and medically important fungi in the genera *Aspergillus* and *Penicillium*.
1269 *mBio.* 10(4):e00925-19. doi:10.1128/mBio.00925-19
1270
- 1271 Summerbell, R. C., and Schroers, H.-J. 2002. Analysis of phylogenetic relationship of *Cylindrocarpon*
1272 *lichenicola* and *Acremonium falciforme* to the *Fusarium solani* species complex and review of
1273 similarities in the spectrum of opportunistic infections caused by these fungi. *J. Clin. Microbiol.*
1274 40:2866-2875.
1275

- 1276 Summerell, B. A. 2019. Resolving *Fusarium*: Current status of the genus. *Annu. Rev. Phytopathol.*
1277 57:323-339.
- 1278
- 1279 Villani, A., Proctor, R. H., Kim, H.-S., Brown, D. W., Logrieco, A. F., Amatulli, M. T., Moretti, A., and Susca,
1280 A. 2019. Variation in secondary metabolite production potential in the *Fusarium incarnatum-equiseti*
1281 species complex revealed by comparative analysis of 13 genomes. *BMC Genomics* 20:314.
- 1282
- 1283 Waalwijk, C., Taga, M., Zheng, S.-L., Proctor, R. H., Vaughan, M. M., and O'Donnell, K. 2018. Karyotype
1284 evolution in *Fusarium*. *IMA Fungus* 9:13-26.
- 1285
- 1286 Watanabe, M., Yonezawa, T., Lee, K.-i., Kumagai, S., Sugita-Konishi, Y., Goto, K., and Hara-Kudo, Y. 2011.
1287 Molecular phylogeny of the higher and lower taxonomy of the *Fusarium* genus and differences in the
1288 evolutionary histories of multiple genes. *BMC Evol. Biol.* 11:322.
- 1289 Wiemann, P., Sieber, C. M. K., Von Bargen, K. W., Studt, L., Niehaus, E. M., Espino, J. J., Huß, K.,
1290 Michielse, C. B., Albermann, S., Wagner, D., Bergner, S. V., Connolly, L. R., Fischer, A., Reuter, G.,
1291 Kleigrewe, K., Bald, T., Wingfield, B. D., Ophir, R., Freeman, S., Hippler, M., Smith, K. M., Brown, D. W.,
1292 Proctor, R. H., Münsterkötter, M., Freitag, M., Humpf, H. U., Guldener, U., and Tudzynski, B. 2013.
1293 Deciphering the cryptic genome: Genome-wide analyses of the rice pathogen *Fusarium fujikuroi*
1294 reveal complex regulation of secondary metabolism and novel metabolites. *PLoS Pathog.* 9:
1295 e1003475.
- 1296
- 1297 Wingfield, M. J., de Beer, W., Slippers, B., Wingfield, B. D., Groenewald, J. Z., Lombard, L., and Crous, P.
1298 W. 2011. One fungus, one name promotes progressive plant pathology. *Mol. Plant Pathol.* 13:604-
1299 613.
- 1300
- 1301 Wollenweber, H. W. 1913. Studies on the *Fusarium* problem. *Phytopathology* 3:24-50.
- 1302
- 1303 Wollenweber, H. W., and Reinking, O. A. 1935. Die Fusarien, ihre Beschreibung, Schadwirkung und
1304 Bekämpfung. Paul Parey, Berlin.
- 1305
- 1306 Zhang, N., Luo, J., Rossman, A. Y., Aoki, T., Chuma, I., Crous, P. W., Dean, R., de Vries, R. P., Donofrio, N.,
1307 Hyde, K. D., Lebrun, M.-H., Talbot, N. J., Tharreau, D., Tosa, Y., Valent, B., Wang, Z., and Xu, J.-R.

- 1308 2016. Generic names in *Magnaporthales*. IMA Fungus 7:155-159.
- 1309 doi:10.5598/imafungus.2016.07.01.09
- 1310
- 1311 Zhou, X., O'Donnell, K., Kim, H.-S., Proctor, R. H., Doehring, G., and Cao, Z.-M. 2018. Heterothallic sexual
- 1312 reproduction in three canker-inducing tree pathogens within the *Fusarium torreyae* species complex.
- 1313 Mycologia 110:710-725.
- 1314

1315 **Figure 1.** Partitioned maximum likelihood bootstrapped (ML-BS) phylogram of *Fusarium*, based on full-
 1316 length exonic nucleotide (nt) sequences of 19 protein-coding genes (Table 1), inferred using IQ-TREE
 1317 (Nguyen et al. 2015). Nodes supported by 100% ML bootstrap (5000 replicates; BS) and 1.0 Bayesian
 1318 posterior probability (BPP), including F1 and F2, are indicated with asterisks; ML-BS/BPP values are
 1319 shown for nodes receiving less than 100%/1.0 support. Two branches highlighted in magenta received
 1320 BS <70 and BPP < 0.99. Two shades of blue highlight 23 species complexes within *Fusarium*. Numerals
 1321 situated adjacent to nodes represent gene concordance factors (gCFs) calculated by IQ-TREE 2 for that
 1322 node, expressed as the number of loci that resolve it out of 19. PIC = parsimony informative characters;
 1323 TC = Tree credibility.

1324
 1325 **Figure 2.** Partitioned maximum likelihood bootstrapped (ML-BS) cladogram of the *F. solani* Species
 1326 Complex (FSSC) based on *tef1*, *rpb2* and rDNA, inferred using IQ-TREE (Nguyen et al. 2015). Clades 1, 2
 1327 and 3 represent designations proposed in O'Donnell (2000). Numerical designations corresponding to an
 1328 informal ad hoc nomenclature for phylogenetic species in the FSSC (e.g., FSSC 1) are provided in
 1329 brackets. The Ambrosia *Fusarium* Clade (Kasson et al. 2013), the clade that encompasses species with
 1330 typical *Neocosmospora* morphology, and the clade consisting of soybean sudden death syndrome (SDS)
 1331 and bean root rot (BRR) pathogens, are indicated. ML-BS values, based on 5000 replicates, are shown for
 1332 each node. + = medically important species, bp, base pairs; PIC = parsimony informative characters; ET =
 1333 epitype isolate; IT = isotype isolate; T = type isolate. *the type of *N. striata*, combined under *F.*
 1334 *bataticola*. †the type of *N. boninensis*, combined under *F. tenuicristatum* (see Appendix A).

1335
 1336 **Supplemental Figure 1.** Cladogram of *Fusarium* 19-locus dataset based on Bayesian inference. Numbers
 1337 below nodes indicate Bayesian posterior probability on a 0-100 scale.

1338
 1339 **Supplemental Figure 2.** Individual maximum likelihood bootstrap phylograms of 19 individual gene trees.
 1340 Locus names and molecular evolutionary models used in IQ-TREE are as listed in Table 1. Numbers
 1341 above or adjacent to nodes indicate bootstrap values (5000 replicates).

1342
 1343 **Supplemental Figure 3.** Cladogram of *Fusarium* inferred using IQ-TREE, with Internode Credibility (IC)
 1344 and Internode Credibility-All (ICA) values presented below nodes.

1345

Table 1. Phylogenetic data summary of 19 genes analyzed in the present study.

Locus	Protein encoded	Identifier ¹	Chr ²	nt sites	AA ³	PIC ⁴	PIC/ site	% total PICs	Model ⁵
<i>acl1</i>	ATP citrate lyase large subunit	FFUJ_13230	4	1473	490	505	0.34	2.13%	TN+F+I+G4
<i>act1*</i>	Actin	FFUJ_00687	1	1425	474	641	0.45	2.71%	TIM2+F+I+G4
<i>cal1*</i>	Calmodulin	FFUJ_12207	8	450	149	117	0.26	0.49%	TNe+I+G4
<i>cpr1</i>	Cytochrome P450 reductase	FFUJ_04716	2	2085	694	949	0.46	4.01%	TIM2+F+I+G4
<i>dpa1</i>	DNA polymerase alpha subunit	FFUJ_08551	7	4491	1498	2233	0.50	9.43%	GTR+F+I+G4
<i>dpe*1</i>	DNA polymerase epsilon subunit	FFUJ_13258	4	6699	2232	3005	0.45	12.70%	GTR+F+I+G4
<i>fas1</i>	Fatty acid synthase alpha subunit	FFUJ_04562	2	5622	1880	2191	0.39	9.26%	TIM2+F+I+G4
<i>fas2</i>	Fatty acid synthase beta subunit	FFUJ_04563	2	6330	2109	2608	0.41	11.02%	TN+F+I+G4
<i>ku70*</i>	ATP-dependent DNA helicase II	FFUJ_04557	2	1959	652	1020	0.52	4.31%	SYM+I+G4
<i>lcb2</i>	Sphinganine palmitoyl transferase subunit	FFUJ_09546	9	2121	706	910	0.42	3.84%	TIM2+F+I+G4
<i>mcm7</i>	DNA replication licensing factor	FFUJ_02741	3	2526	841	1211	0.48	5.12%	GTR+F+I+G4
<i>pgk1*</i>	Phosphoglycerate kinase	FFUJ_09403	9	1257	418	447	0.36	1.89%	TIM2+F+I+G4
<i>rpb1</i>	RNA polymerase largest subunit	FFUJ_00736	1	5382	1793	2348	0.44	9.92%	TIM2+F+I+G4
<i>rpb2</i>	RNA polymerase 2nd largest subunit	FFUJ_07996	5	3882	1293	1667	0.43	7.04%	TIM2e+F+I+G4
<i>tef1*</i>	Translation elongation factor 1-alpha	FFUJ_05795	6	1383	460	299	0.22	1.26%	GTR+F+I+G4
<i>top1</i>	Topoisomerase	FFUJ_02999	3	2859	952	1505	0.53	6.36%	TIM2+F+I+G4
<i>tsr1</i>	Ribosomal biogenesis protein	FFUJ_09872	9	2493	830	1261	0.51	5.33%	GTR+F+I+G4
<i>tub1</i>	Tubulin alpha subunit	FFUJ_00614	1	1350	449	383	0.28	1.62%	TIM+F+I+G4
<i>tub2*</i>	Tubulin beta subunit	FFUJ_04397	2	1353	450	368	0.27	1.55%	TN+F+I+G4
TOTAL:				55140	18370	23668		100.00%	

*Individual gene tree does not resolve F1

¹Gene identifier in the *Fusarium fujikuroi* genome (Wiemann et al. 2013)

²Chromosomal location as mapped to the *Fusarium fujikuroi* genome (Wiemann et al. 2013)

³Amino acid count, which does not account for in-frame insertions/deletions

⁴Parsimony-informative characters in the nucleotide alignment

⁵Best evolutionary model as determined by Bayesian Information Criterion estimated in IQ-Tree

Supplemental Table 1. GenBank accessions for genome sequences.

Species	Isolate	GenBank Accession
<i>F. albidum</i>	NRRL 22152	JABFEP000000000
<i>F. albosuccineum</i>	NRRL 20459	JAADYS000000000
<i>F. ambrosium</i>	NRRL 62606	NKCL00000000*
<i>F. anguioides</i>	NRRL 25385	JAALXK000000000**
<i>F. armeniacum</i>	NRRL 6227	JABFEC000000000
<i>F. asiaticum</i>	NRRL 26156	JABFEQ000000000
<i>F. avenaceum</i>	NRRL 54939 = Fa05001	JPYM00000000*
<i>F. aywerte</i>	NRRL 25410	JABCQV000000000**
<i>F. babinda</i>	NRRL 25539	JABCKA000000000
<i>F. buharicum</i>	NRRL 13371	JAATHB000000000
<i>F. beomiforme</i>	NRRL 25174	PVQB00000000*
<i>F. buxicola</i>	NRRL 36148	JAAVUK000000000
<i>F. chlamydosporum</i>	NRRL 13444	JAAVUD000000000
<i>F. circinatum</i>	NRRL 25331	JAAQPE000000000
<i>F. commune</i>	NRRL 28387	JABFES000000000
<i>F. compactum</i>	NRRL 13829	JABFET000000000
<i>F. concolor</i>	NRRL 13459	JABCJY000000000**
<i>F. continuum</i>	NRRL 66286	JABCKB000000000**
<i>F. culmorum</i>	NRRL 25475	JABFEU000000000
<i>F. cyanostoma</i>	NRRL 53998	JABCKW000000000
<i>F. decemcellulare</i>	NRRL 13412	JAAGWO000000000**
<i>F. dimerum</i>	NRRL 20691	JABGLY000000000
<i>F. domesticum</i>	NRRL 29976	JABFEV000000000
<i>F. equiseti</i>	NRRL 66338	QGEB00000000*
<i>F. falciforme</i>	NRRL 43529	JABEEK000000000**
<i>F. foetens</i>	NRRL 38302	JABFMM000000000
<i>F. fujikuroi</i>	NRRL 5538 = IMI 58289	GCF_900079805.1*
<i>F. gaditjirrii</i>	NRRL 45417	JABFAI000000000**
<i>F. graminearum</i>	NRRL 31084 = PH-1	GCA_900044135.1*
<i>F. graminum</i>	NRRL 20692	JAAGWP000000000**
<i>F. guttiforme</i>	NRRL 22945	JAAQRL000000000
<i>F. hainanense</i>	NRRL 66475	JABFEW000000000
<i>F. heterosporum</i>	NRRL 20693	JAAGWQ000000000**
<i>F. hostae</i>	NRRL 29888	JABCJX000000000**
<i>F. illudens</i>	NRRL 22090	JABFEX000000000
<i>F. irregulare</i>	NRRL 31160	QGEA00000000*
<i>F. langsethiae</i>	NRRL 53436 = FI201059	JXCE00000000.1*
<i>F. lateritium</i>	NRRL 13362	JAAVTZ000000000
<i>F. longipes</i> – 4***	NRRL 13317	JABFEY000000000
<i>F. longipes</i> – 1***	NRRL 13368	JABFEZ000000000

<i>F. lyarnte</i>	NRRL 54252	JAAVUB000000000
<i>F. mangiferae</i>	NRRL25226	FCQH00000000*
<i>F. miscanthi</i>	NRRL 26231	JAAVUA000000000
<i>F. nelsonii</i>	NRRL 13338	JAAVUC000000000
<i>F. nematophilum</i>	NRRL 54600	JABFFA000000000
<i>F. neocosmosporiellum</i>	NRRL 22166	SSHR00000000*
<i>F. newnesense</i>	NRRL 66241	JABCJW000000000**
<i>F. nisikadoi</i>	NRRL 25179	JABFFB000000000
<i>F. nurragi</i>	NRRL 36452	JAALXI000000000**
<i>F. oxysporum</i>	NRRL 32931	AFML00000000*
<i>F. oxysporum</i>	NRRL 34936 = Fo4827	AAXH00000000*
<i>F. penzigii</i>	NRRL 20711	JABFFC000000000
<i>F. poae</i>	NRRL 26941	JABFFD000000000
<i>F. praegraminearum</i>	NRRL 39664	LXHY00000000*
<i>F. pseudograminearum</i>	NRRL 28062	GCA_000974265.2*
<i>F. redolens</i>	NRRL 22901	JAAVUJ000000000
<i>F. rusci</i>	NRRL 22134	JADBHU000000000
<i>F. sacchari</i>	NRRL 66326	JABSTH000000000** †
<i>F. sambucinum</i>	NRRL 13708	JAAVUG000000000
<i>F. sarcochromum</i>	NRRL 20472	JABEXW000000000**
<i>F. scirpi</i>	NRRL 66328	QHHJ00000000*
<i>F. setosum</i>	NRRL 36526	JABFFE000000000
<i>F. sporotrichioides</i>	NRRL 3299	PXOF00000000*
<i>F. staphyleae</i>	NRRL 22316	JADDON000000000
<i>F. stilboides</i>	NRRL 20429	JAASAY000000000
<i>F. subglutinans</i>	NRRL 66333	JAAOAV000000000** †
<i>F. sublunatum</i>	NRRL 13384	JABFFF000000000
<i>F. thapsinum</i>	NRRL 22049	JAAOAX000000000** †
<i>F. torreyae</i>	NRRL 54149	JABEET000000000
<i>F. torulosum</i>	NRRL 22747	JABFMN000000000
<i>F. transvaalense</i>	NRRL 31008	JABFFG000000000
<i>F. tricinctum</i>	NRRL 25481	JAALXJ000000000**
<i>F. vanettenii</i>	NRRL 45880 = 77-13-4	ACJF00000000*
<i>F. venenatum</i>	NRRL 66329	JABFFH000000000
<i>F. ventricosum</i>	NRRL 25729	JABFFI000000000
<i>F. verrucosum</i>	NRRL 22566	JABFFJ000000000
<i>F. verticillioides</i>	NRRL 20956 = FGSC 7600	AAIM00000000*
<i>F. virguliforme</i>	NRRL 31041	JABEEP000000000**
<i>F. xylarioides</i>	NRRL 25486	JABFFK000000000
<i>F. zanthoxyli</i>	NRRL 66285	JABFFL000000000
<i>F. zealandicum</i>	NRRL 22465	JABEYC000000000**
<i>Fusarium</i> sp.	NRRL 25184	JABSSZ000000000
<i>Fusarium</i> sp.	NRRL 52700	JAAQPE000000000** †

<i>Fusarium</i> sp. [AF-6]	NRRL 62590	NKCJ00000000*
<i>Beauveria bassiana</i>	ARSEF 2860	GCA_000280675.1*
<i>Neonectria ditissima</i>	NRRL 20485	JABSTC000000000
<i>Neonectria</i> sp.	NRRL 22505	JABSTB000000000
<i>Neonectria coccinea</i>	NRRL 20487	JABSTD000000000
<i>Trichoderma brevicompactum</i>	IBT 40841	PXNZ00000000.1*

¹ NRRL = USDA/ARS/NCAUR culture collection; IMI = CABI culture collection; FGSC = Fungal Genetics Stock Center; ARSEF = ARS Collection of Entomopathogenic Fungal Cultures; IBT = IBT Culture Collection of Fungi at Danish Technical University. All other strain numbers refer to published non-accession designations.

* Genome sequence data previously reported and deposited in GenBank from other studies

** Genome sequence data produced at USDA-ARS-NCAUR and reported in Kim et al. (2020)

*** Representing undescribed species 1 and 4 within the morphospecies *F. longipes*

† Sequence data generated at the Beijing Genome Institute-Hong Kong for USDA-ARS-NCAUR and reported in Kim et al. (2020)

Fusarium Phylogeny

19 genes
55,140 nt
23,668 PIC

TC = 48.41
relative TC = 0.563
best ML tree:
-927514.615

Species Complex

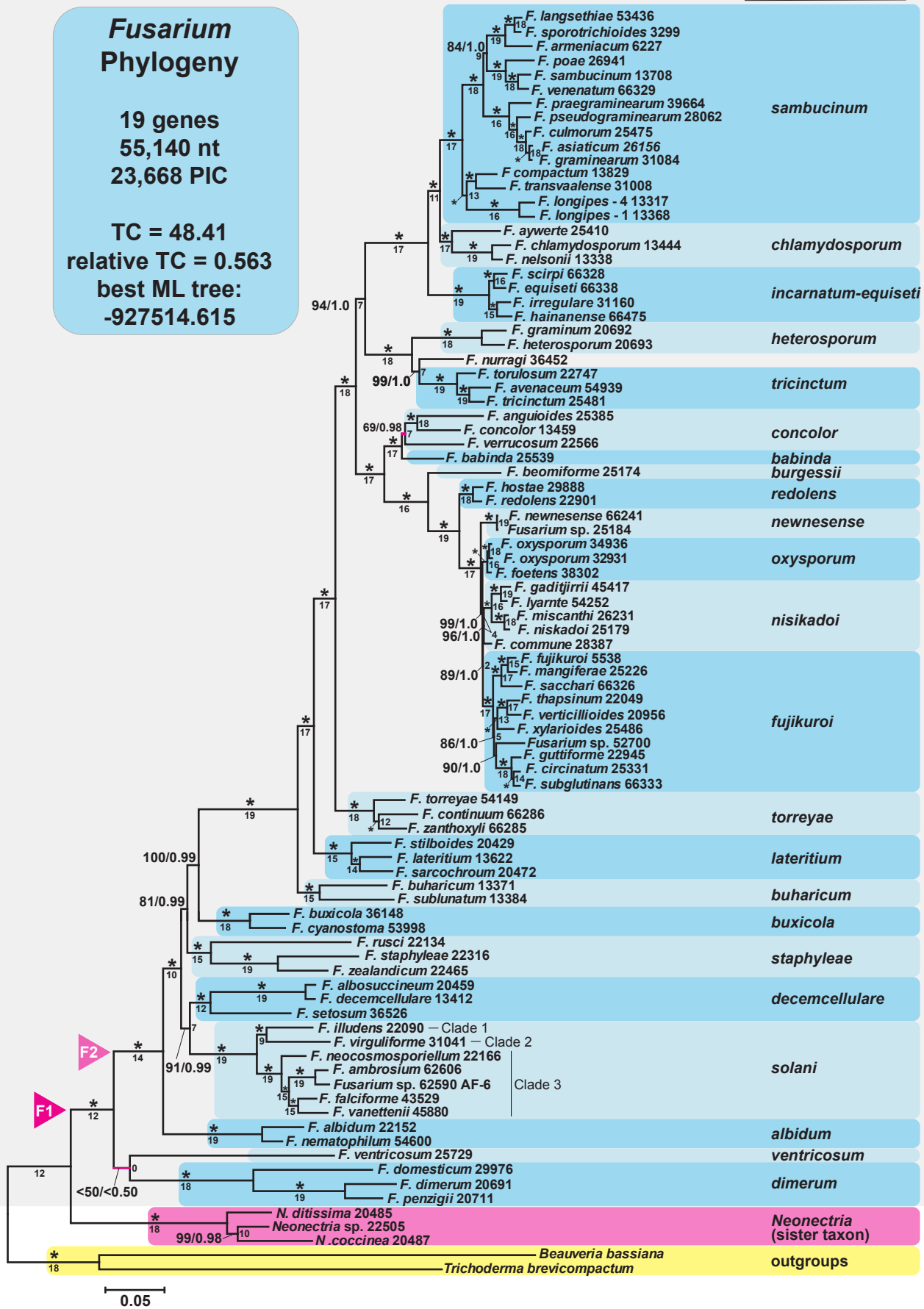

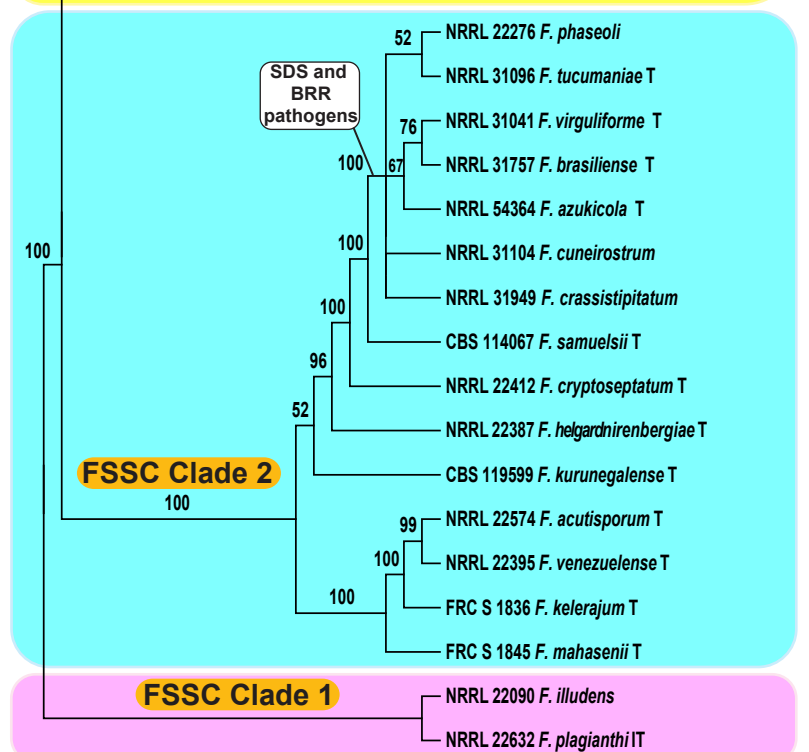
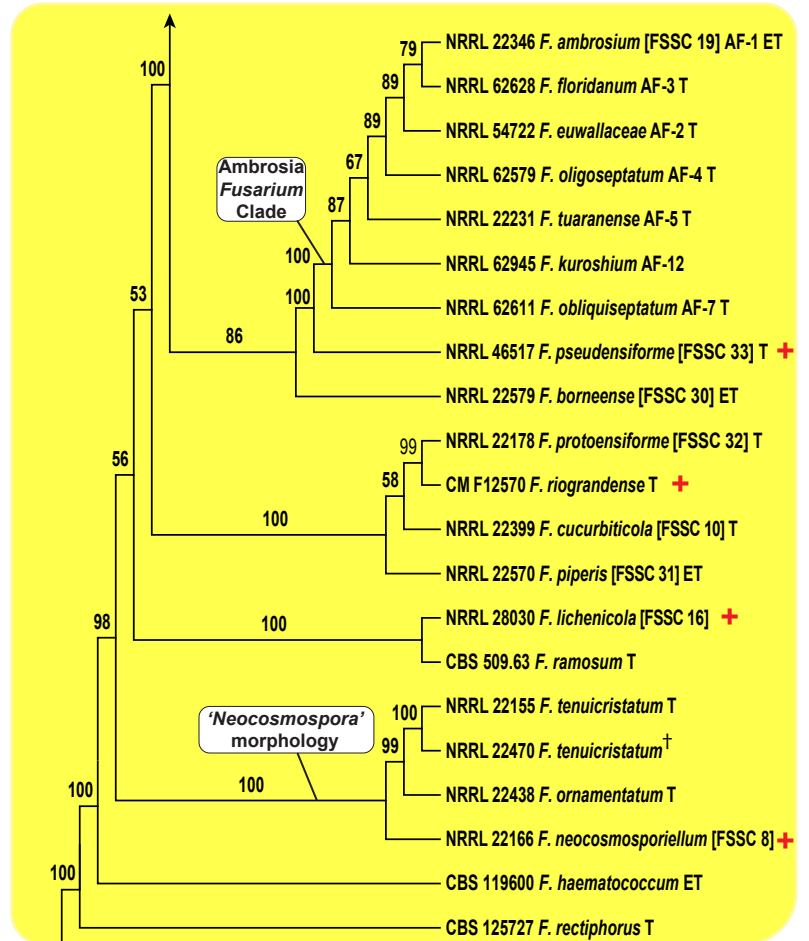
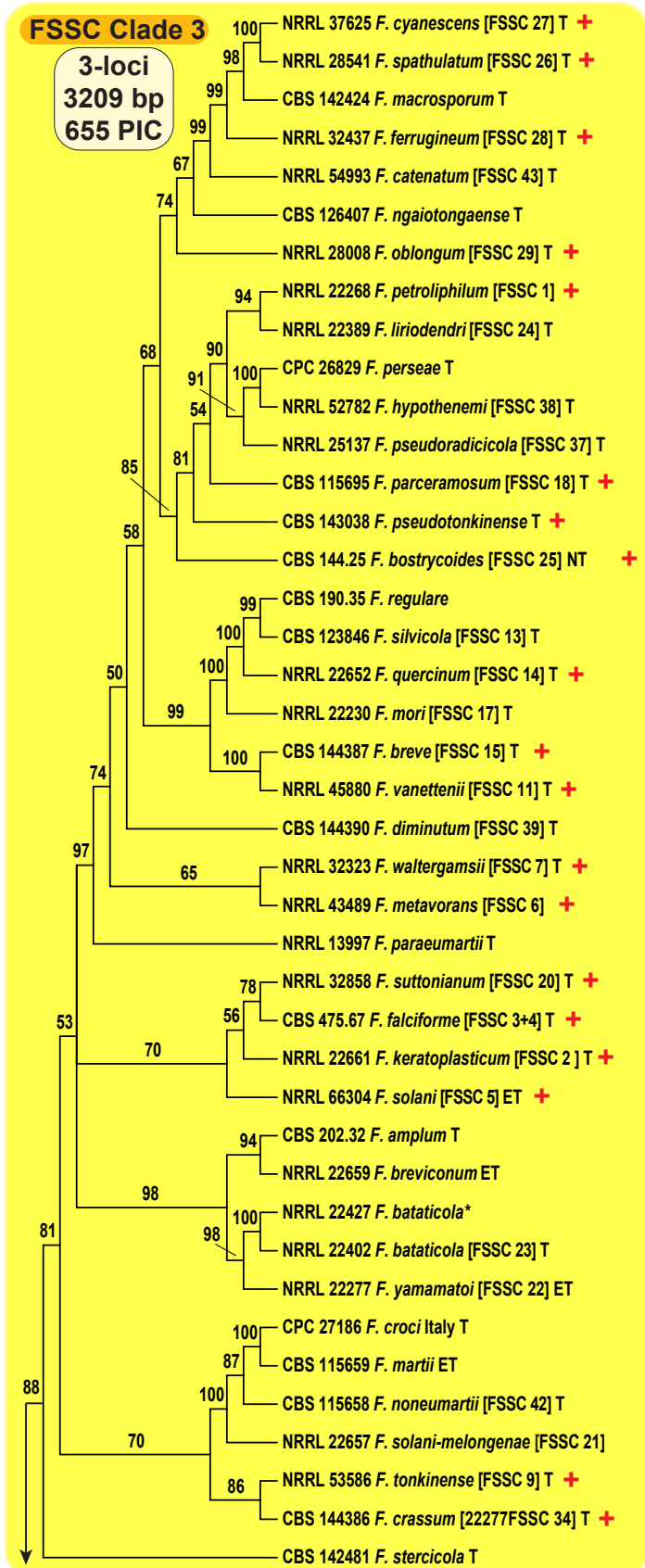

MrBayes Consensus Cladogram

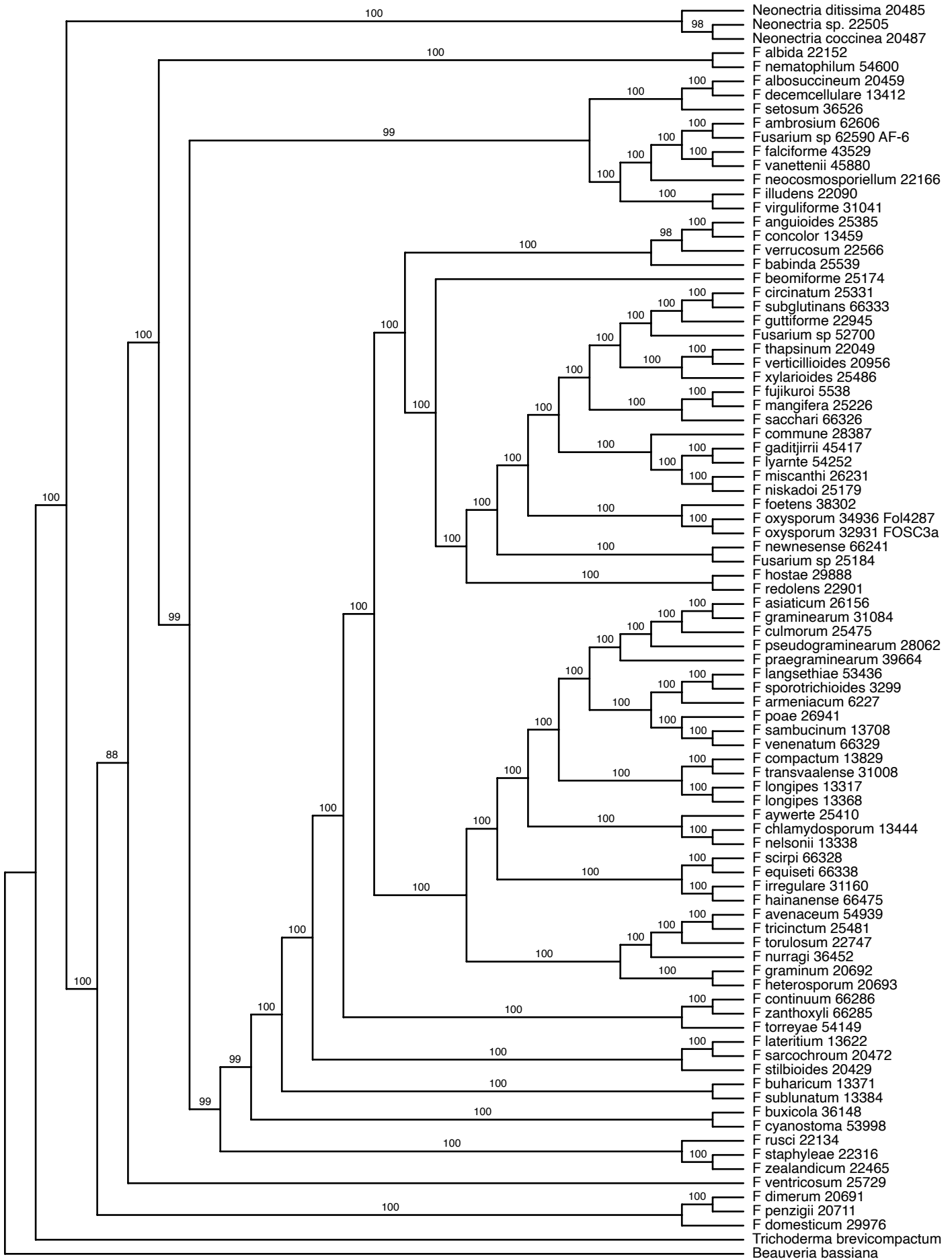

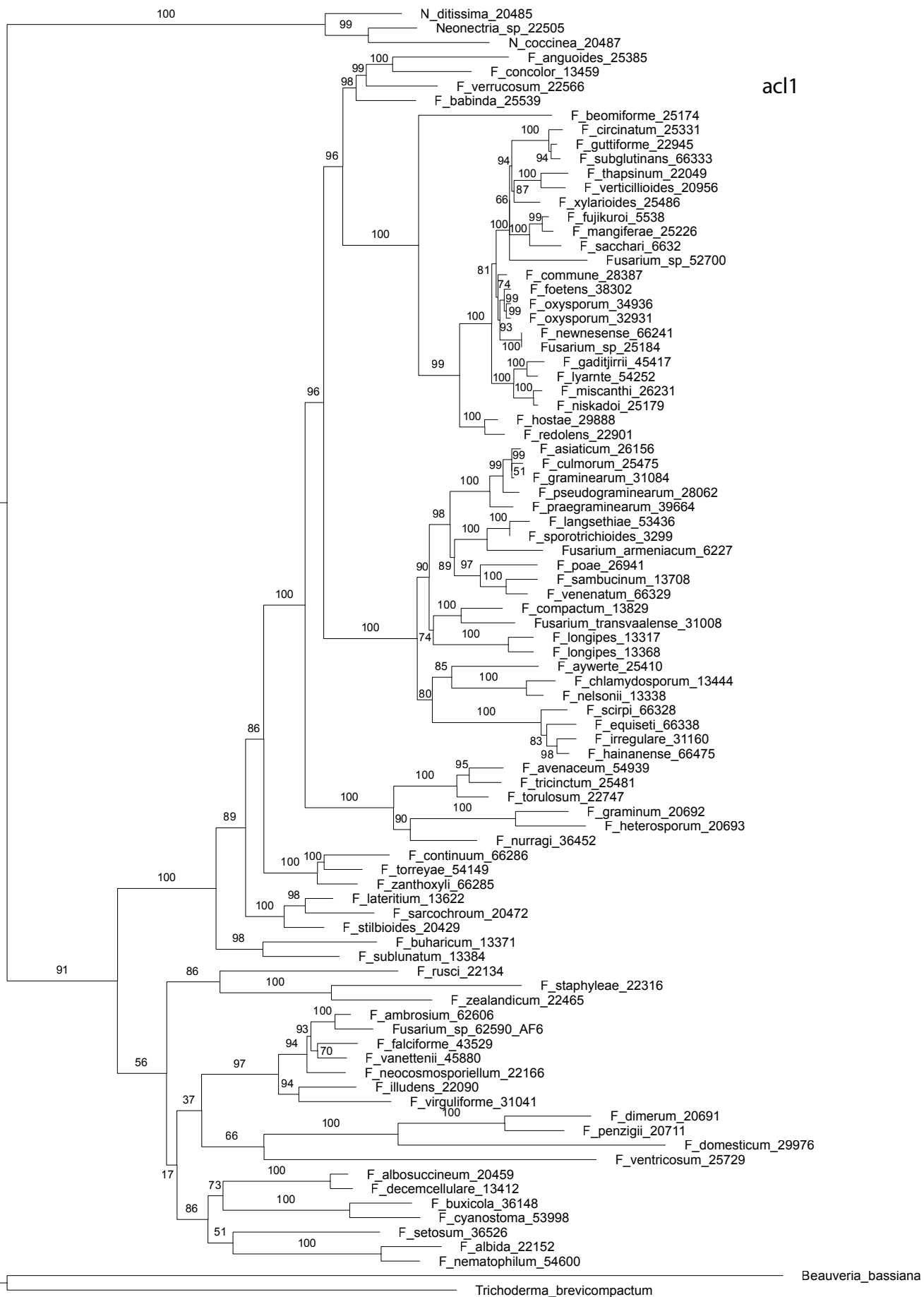

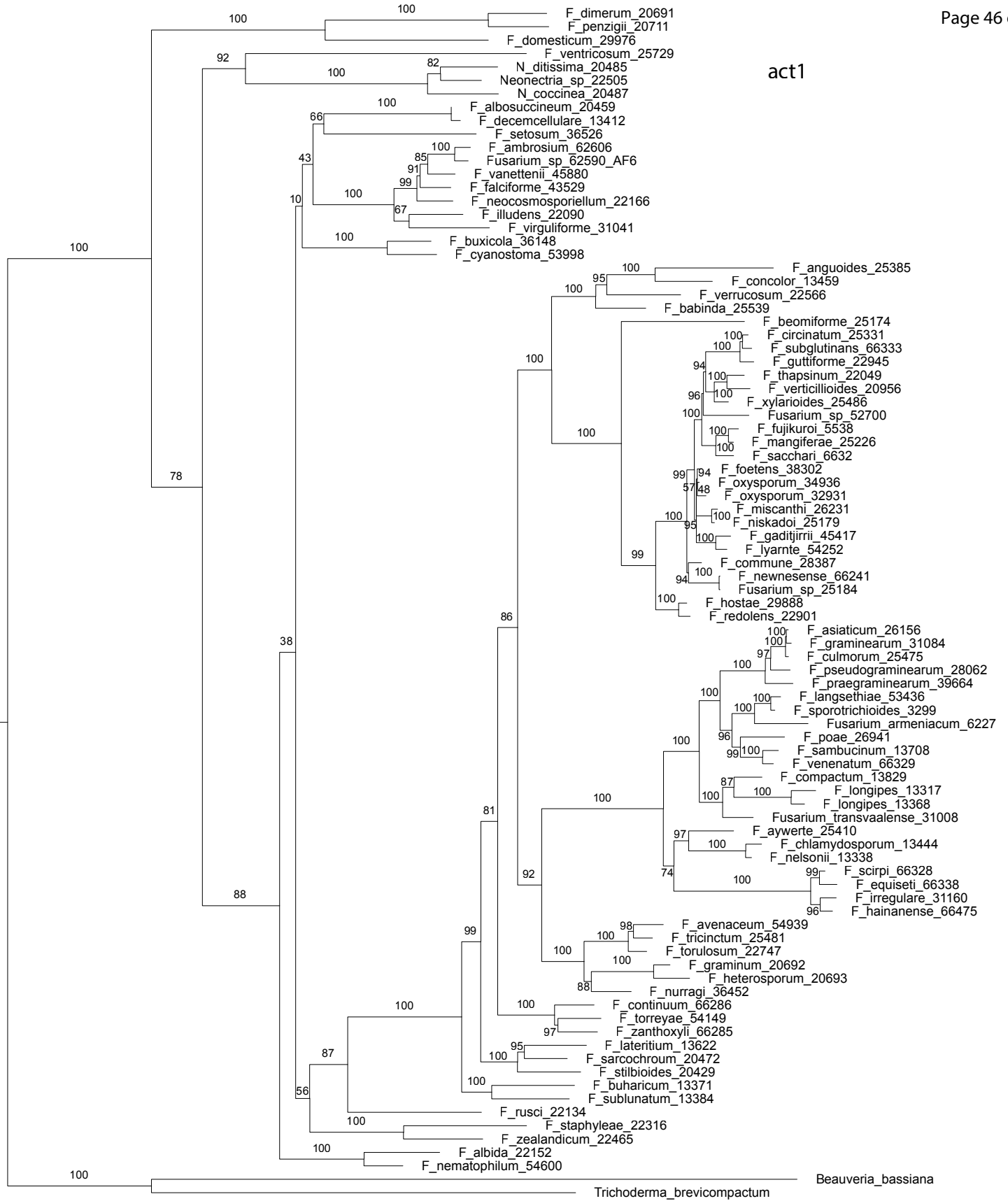

0.09

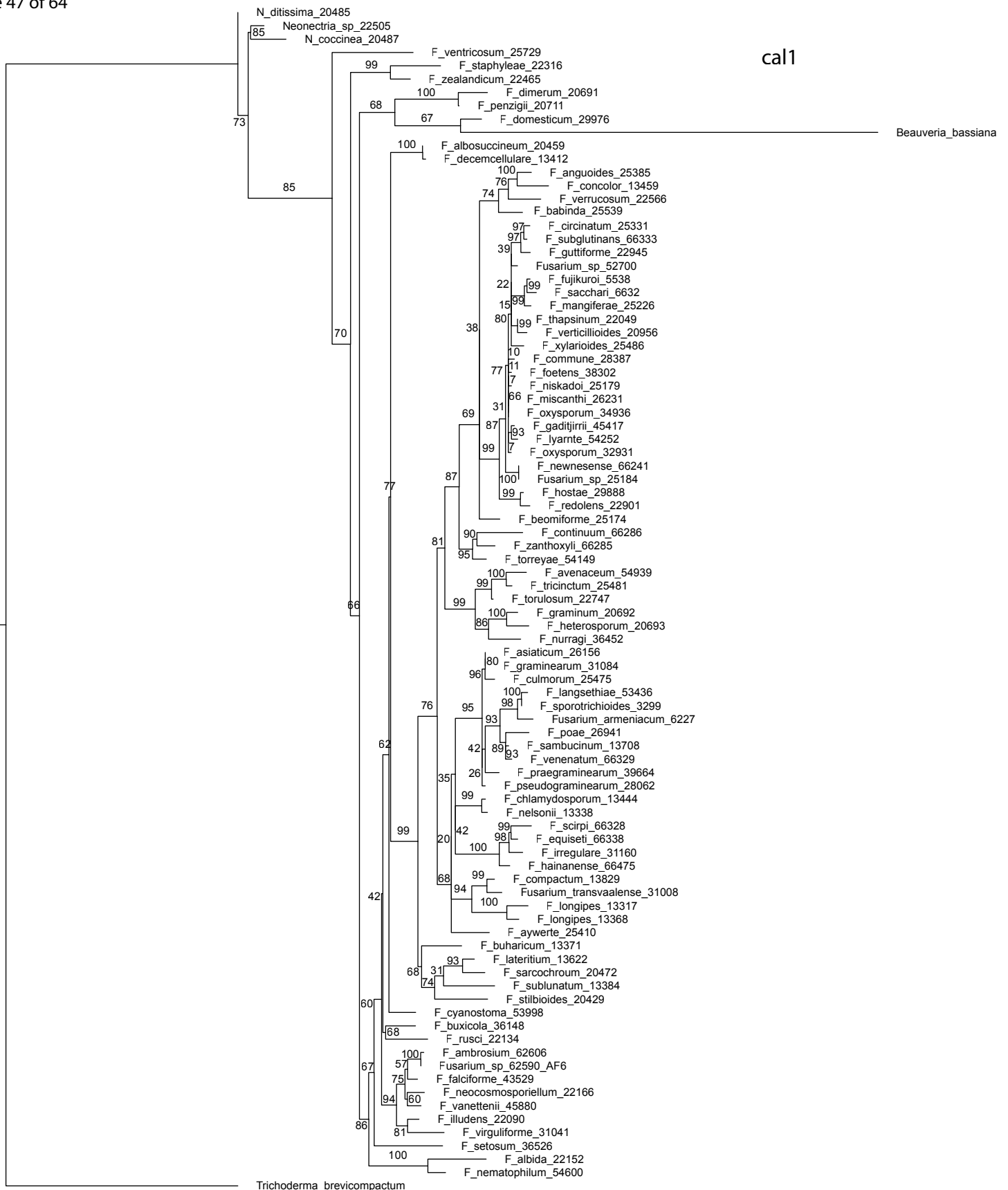

cpr1

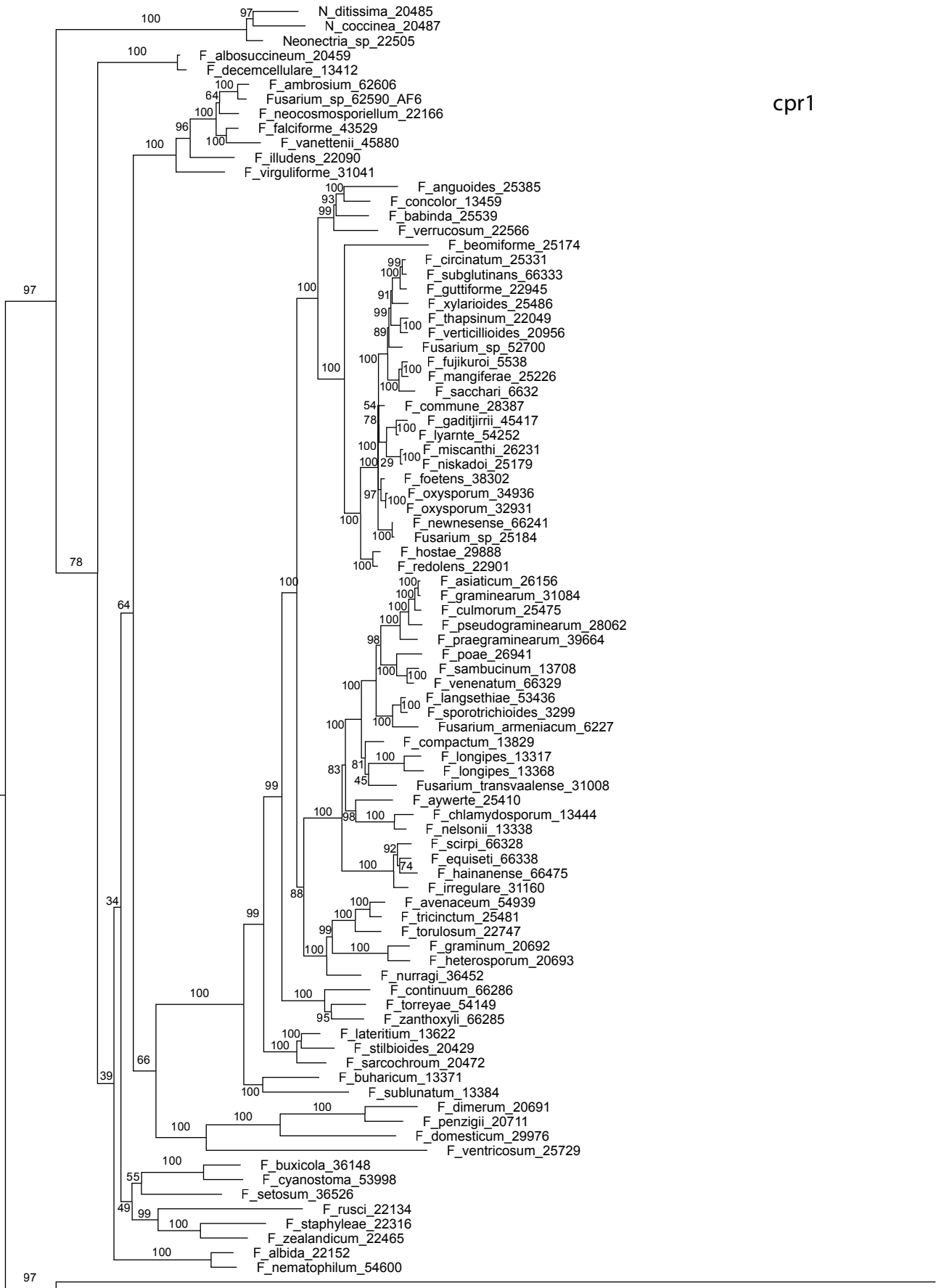

Trichoderma_brevicompectum

Beauveria_bassiana

0.1

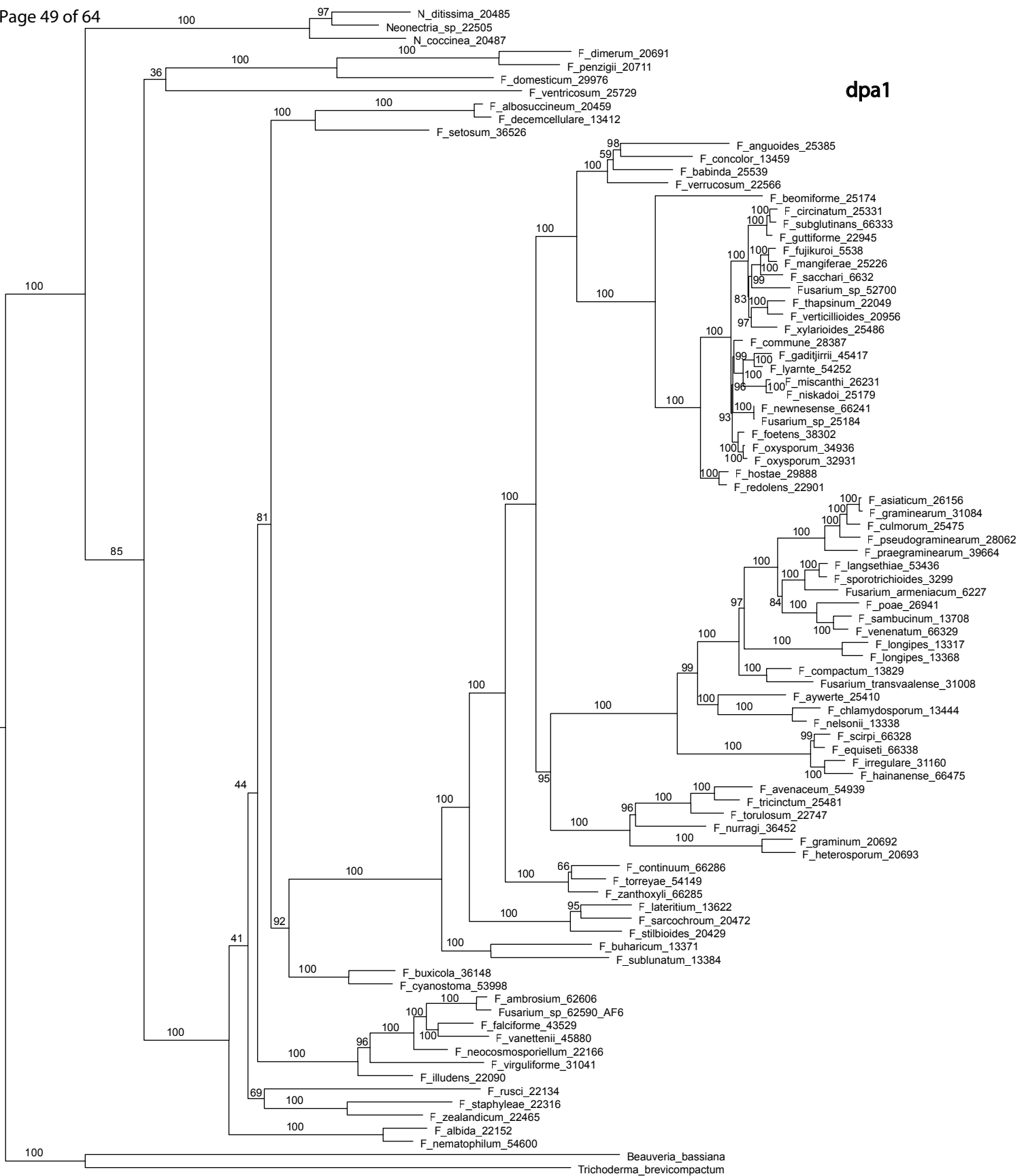

dpa1

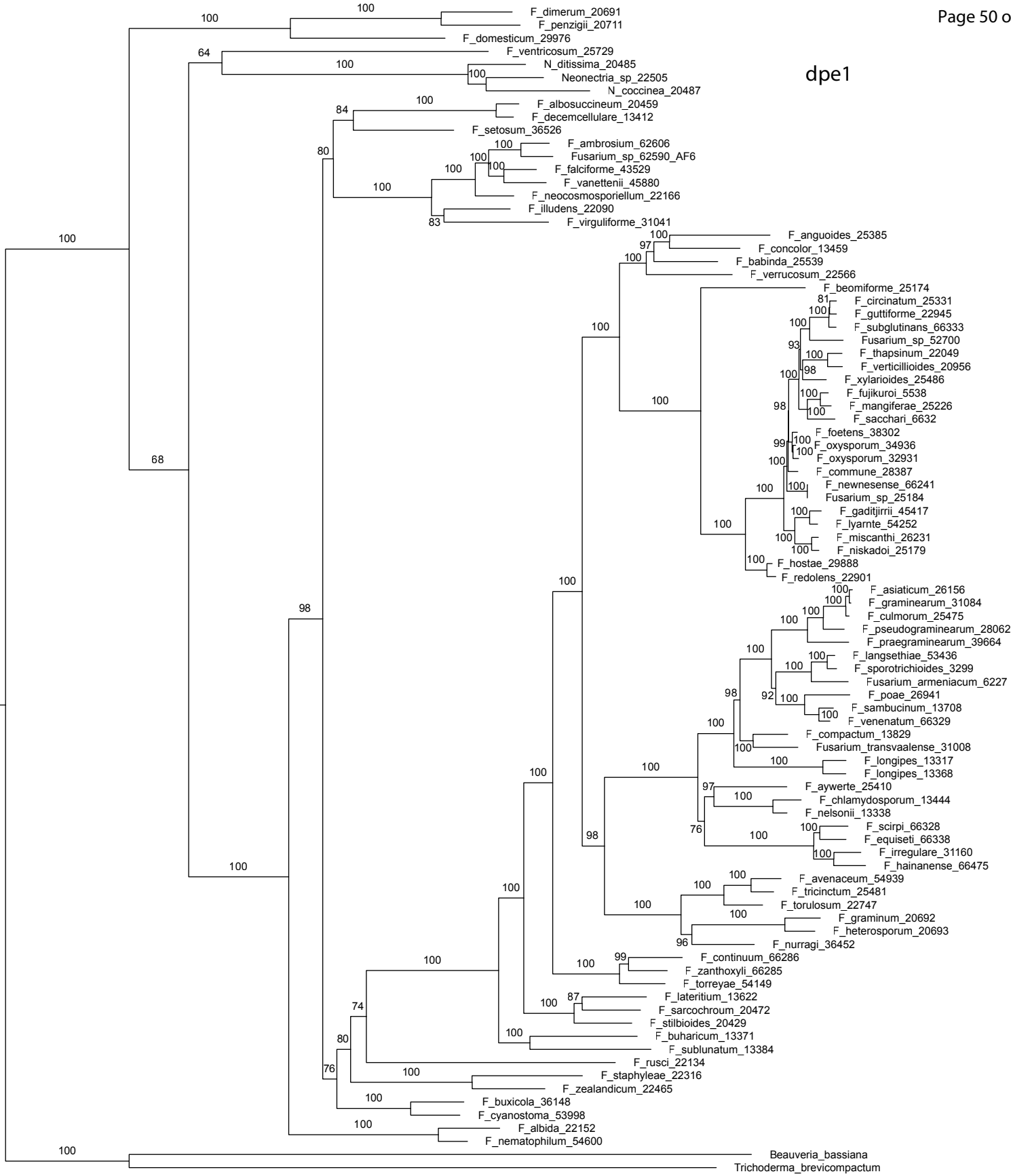

0.09

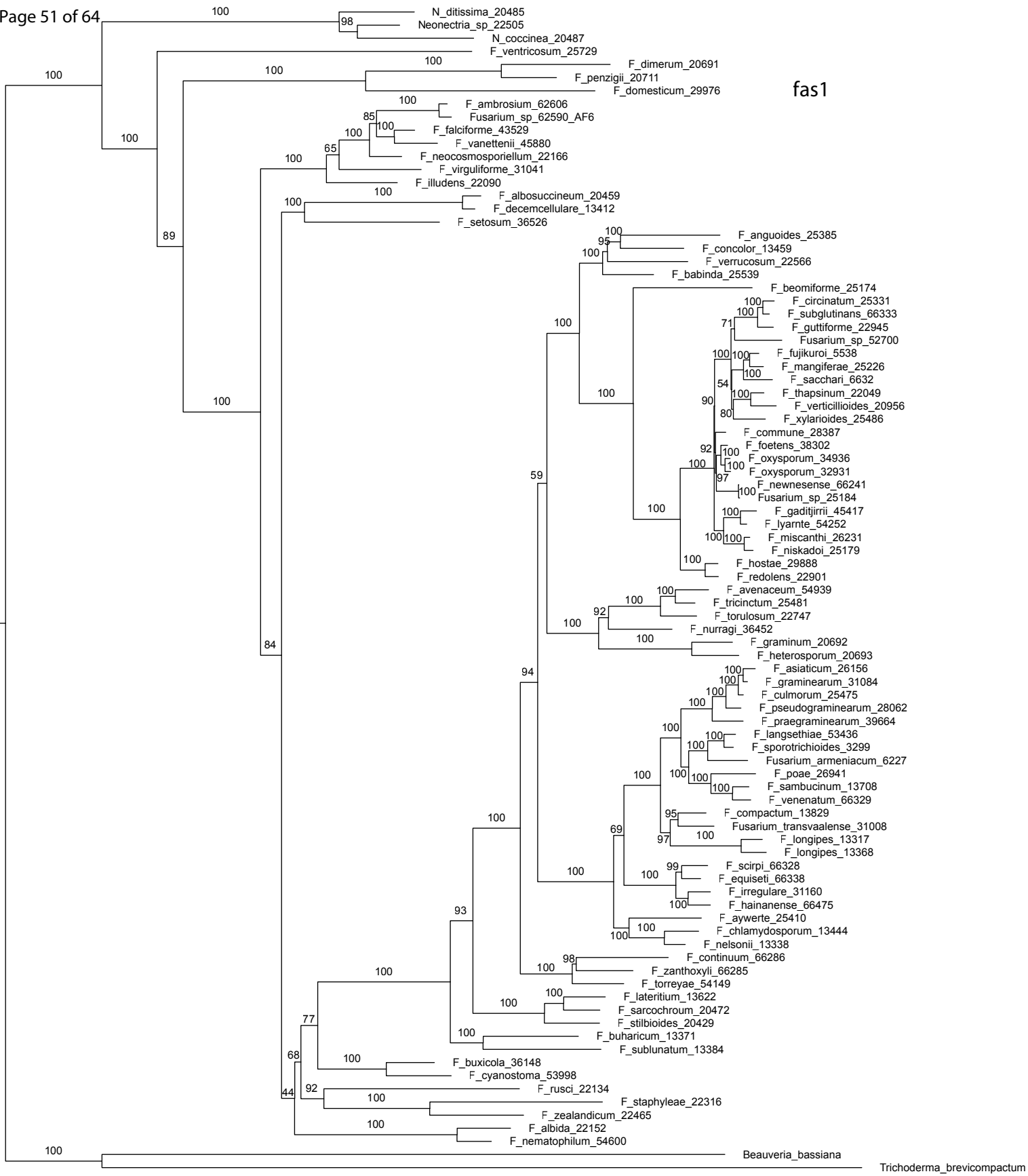

0.06

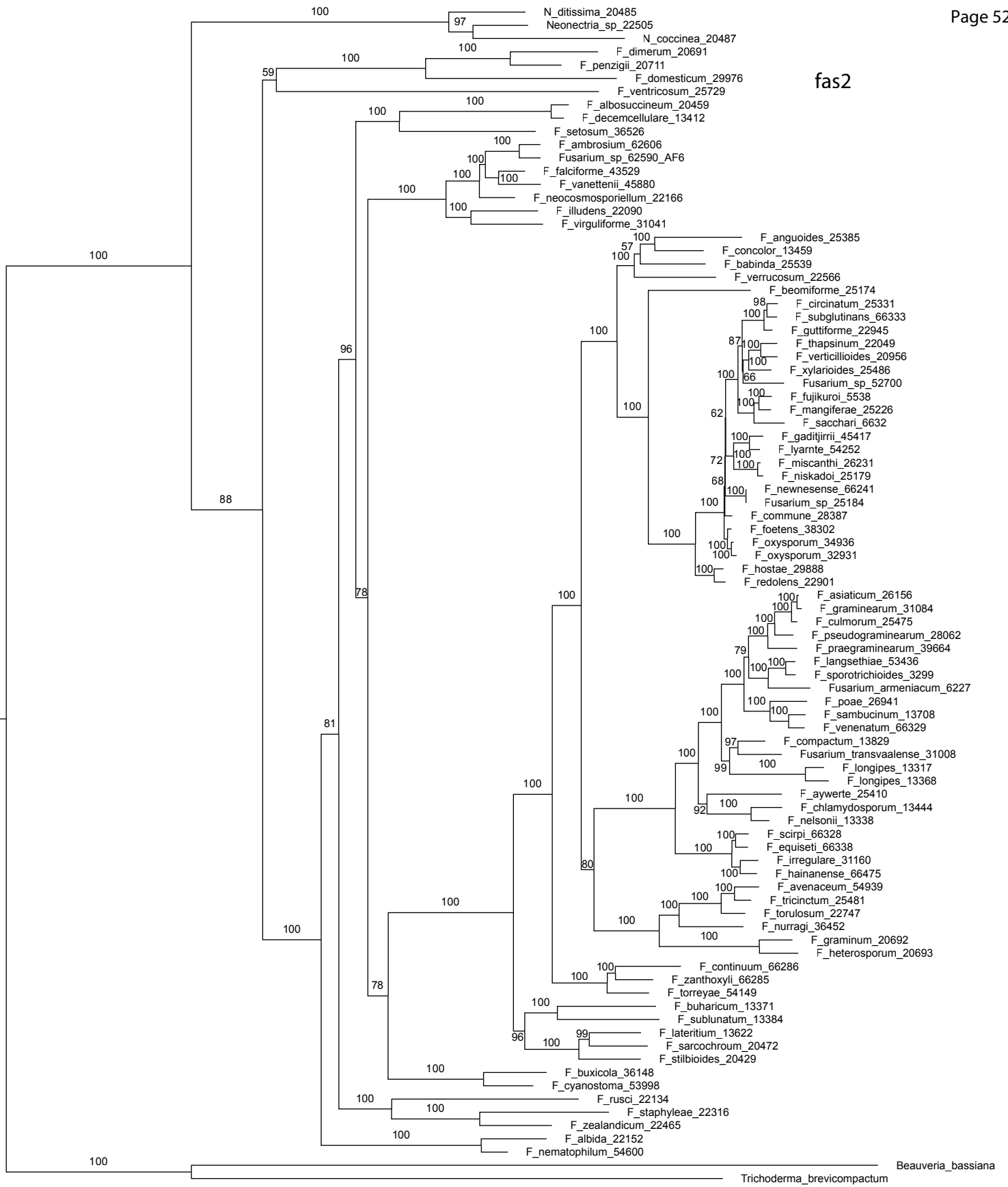

fas2

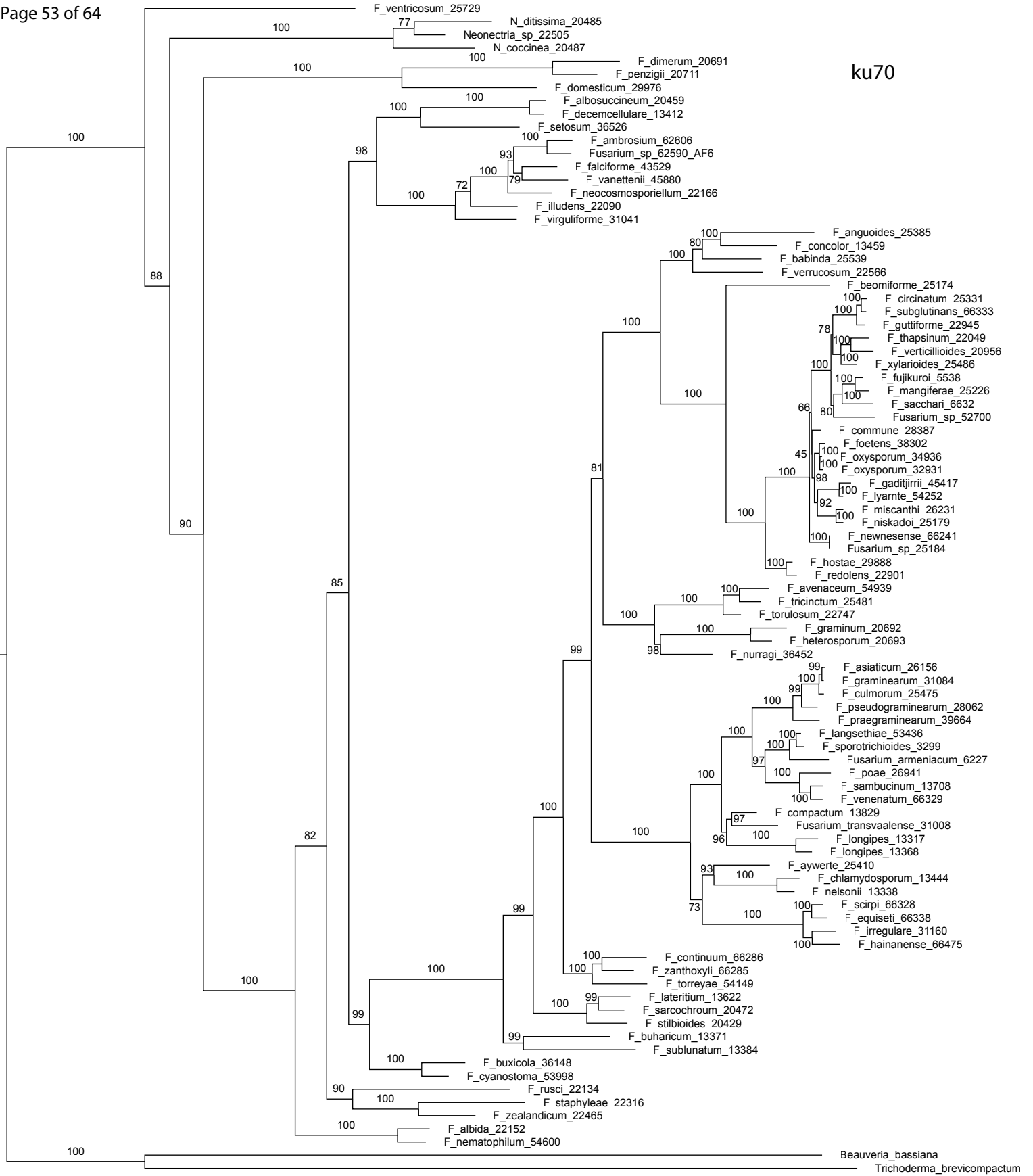

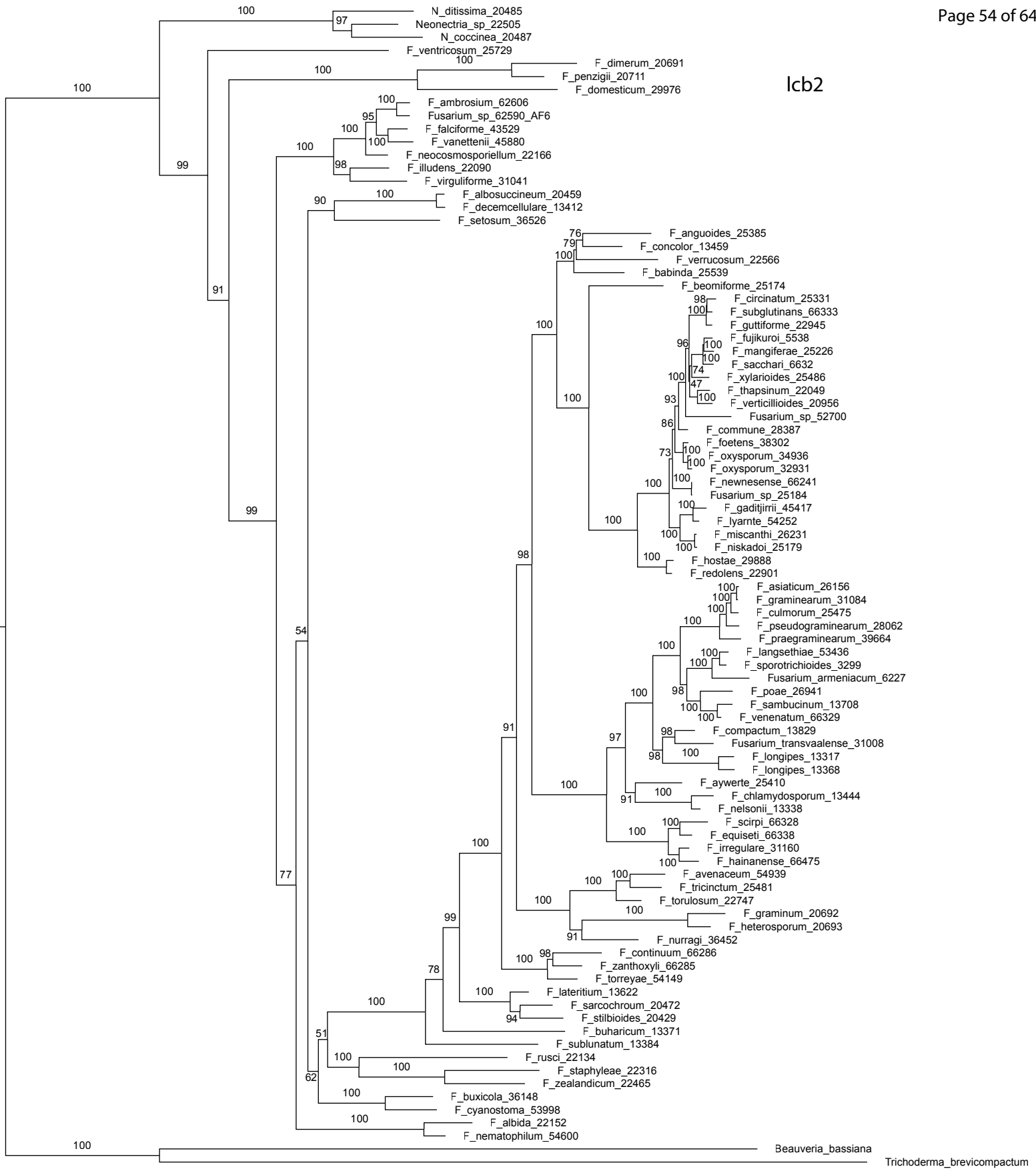

lcb2

Beauveria bassiana
Trichoderma brevicomactum

0.1

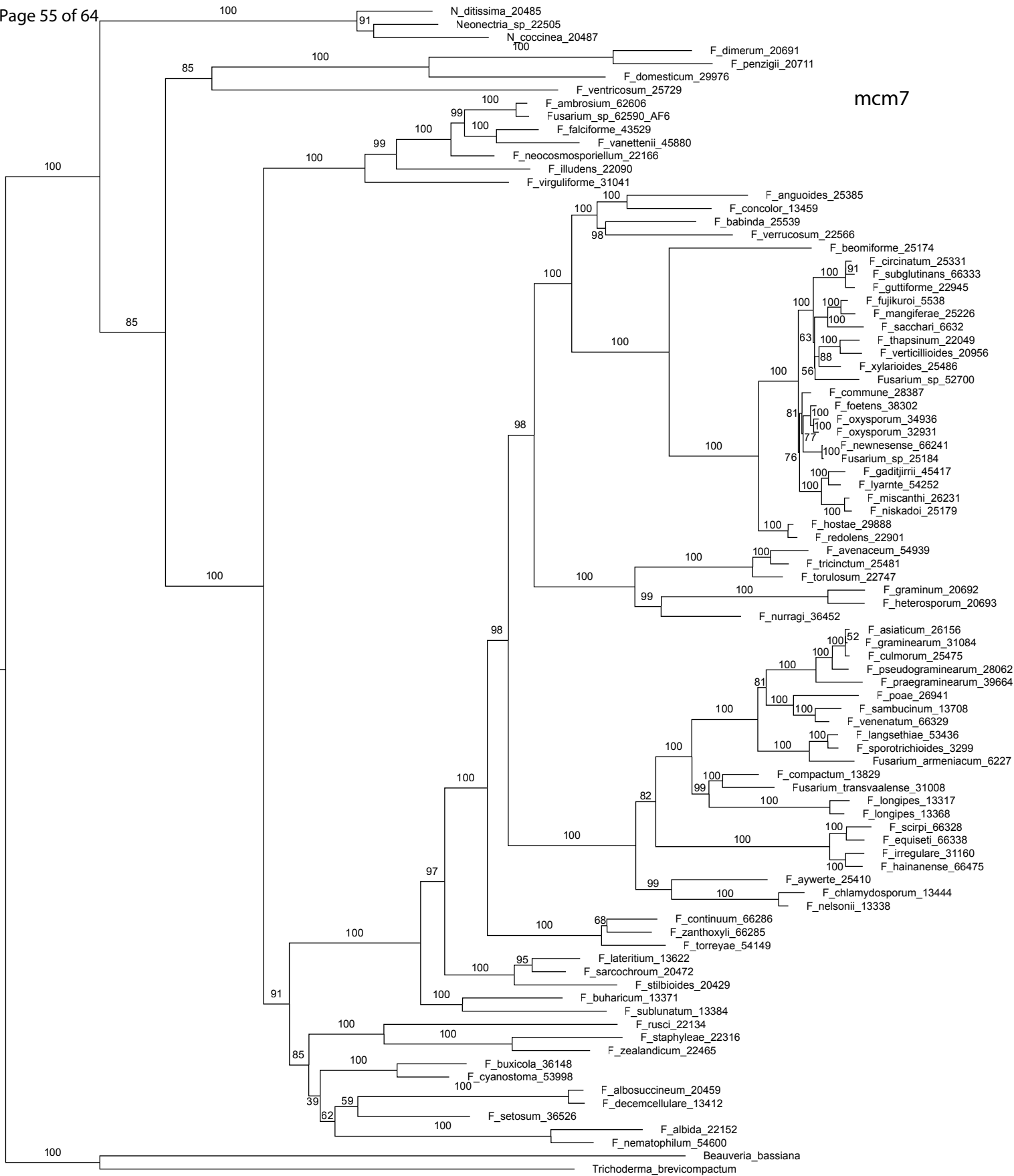

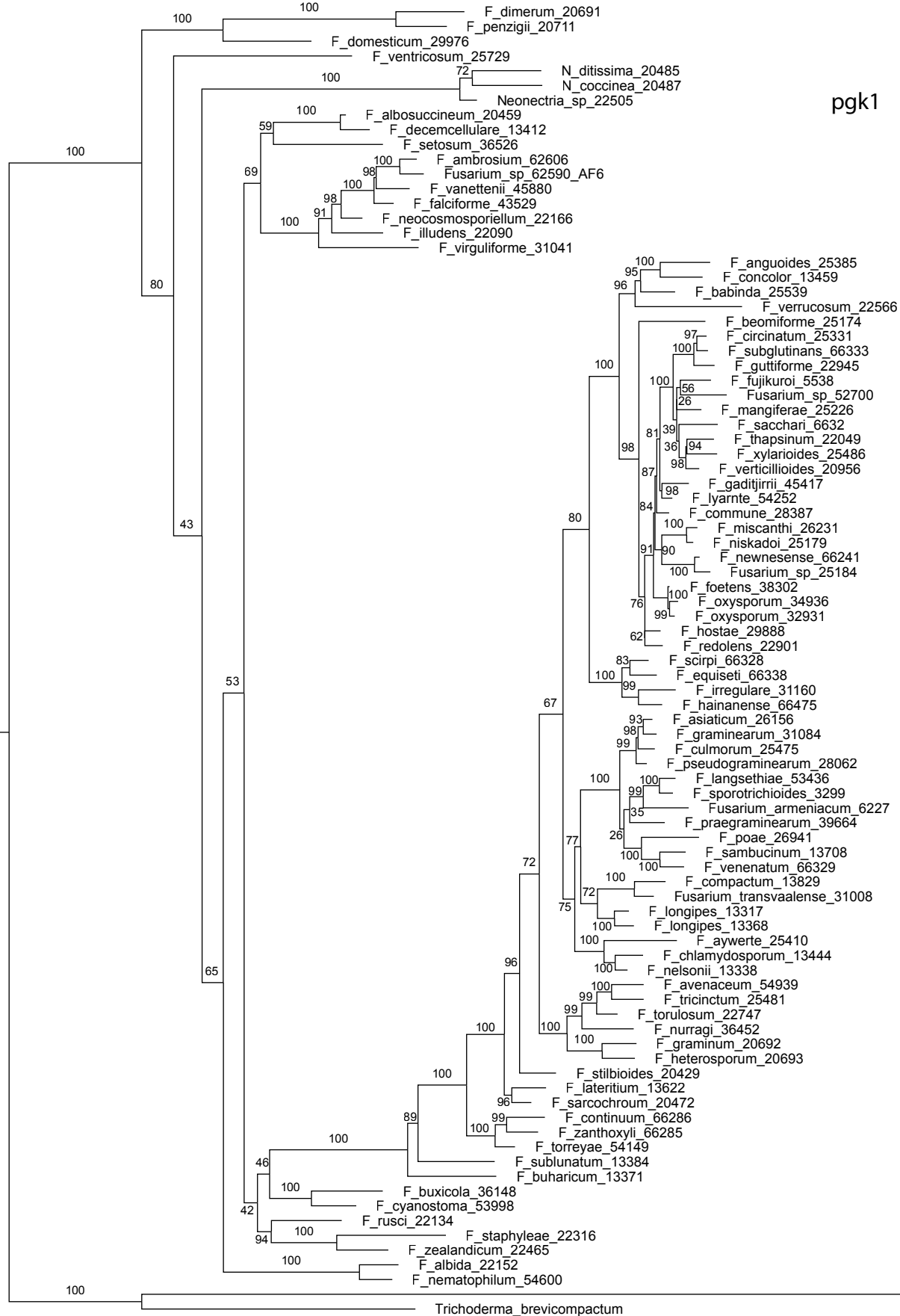

Beauveria_bassiana

0.06

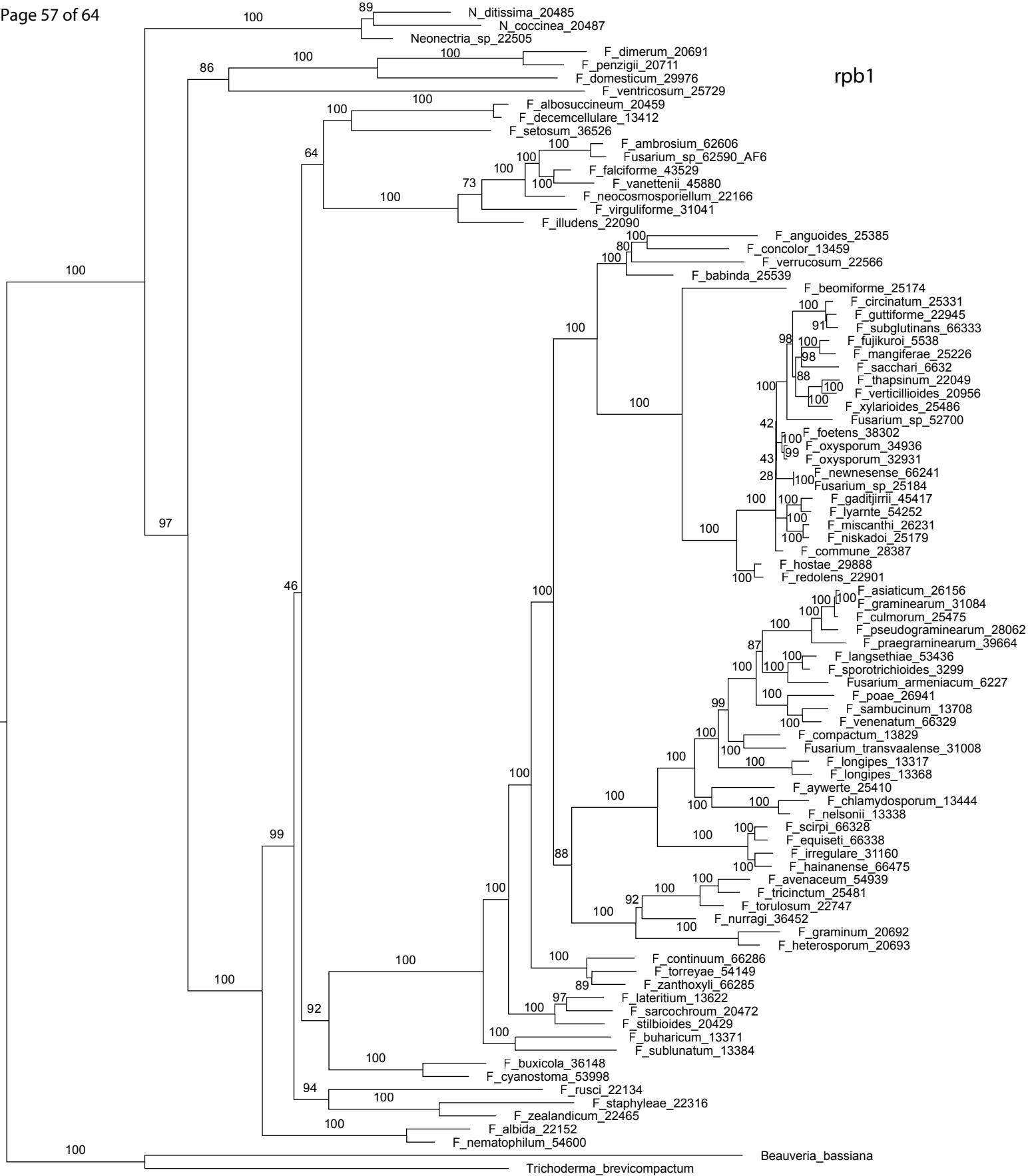

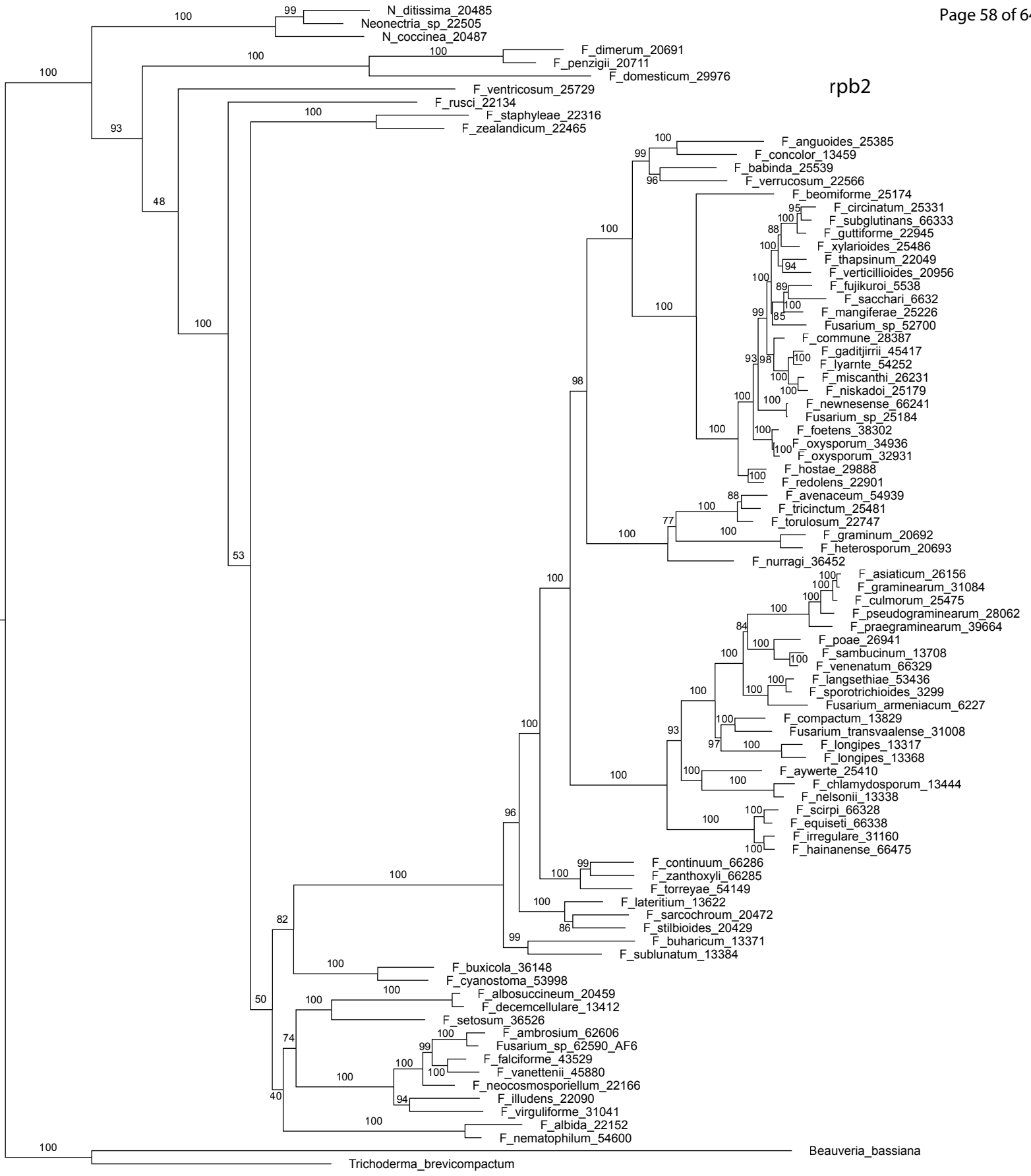

0.09

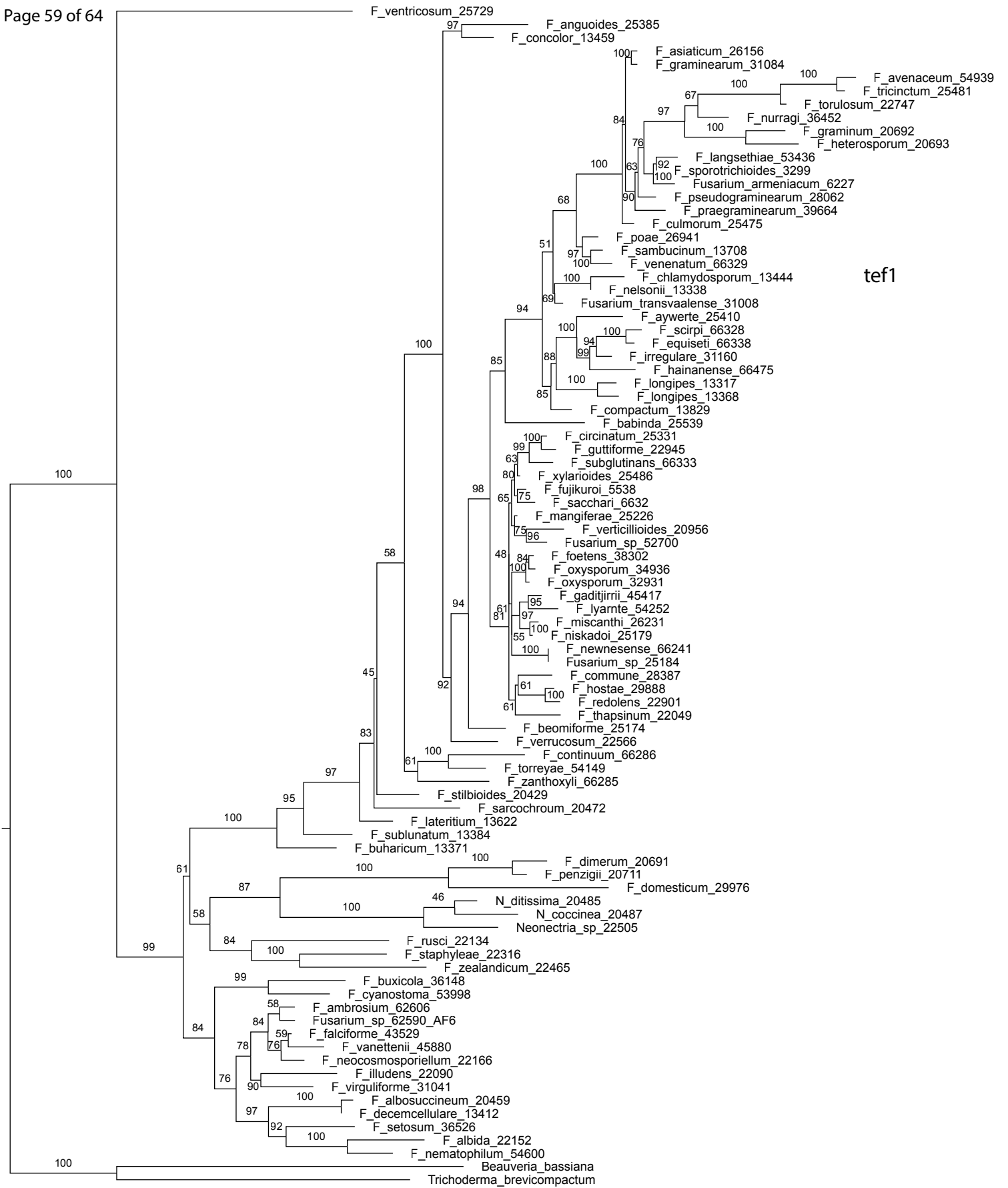

tef1

0.02

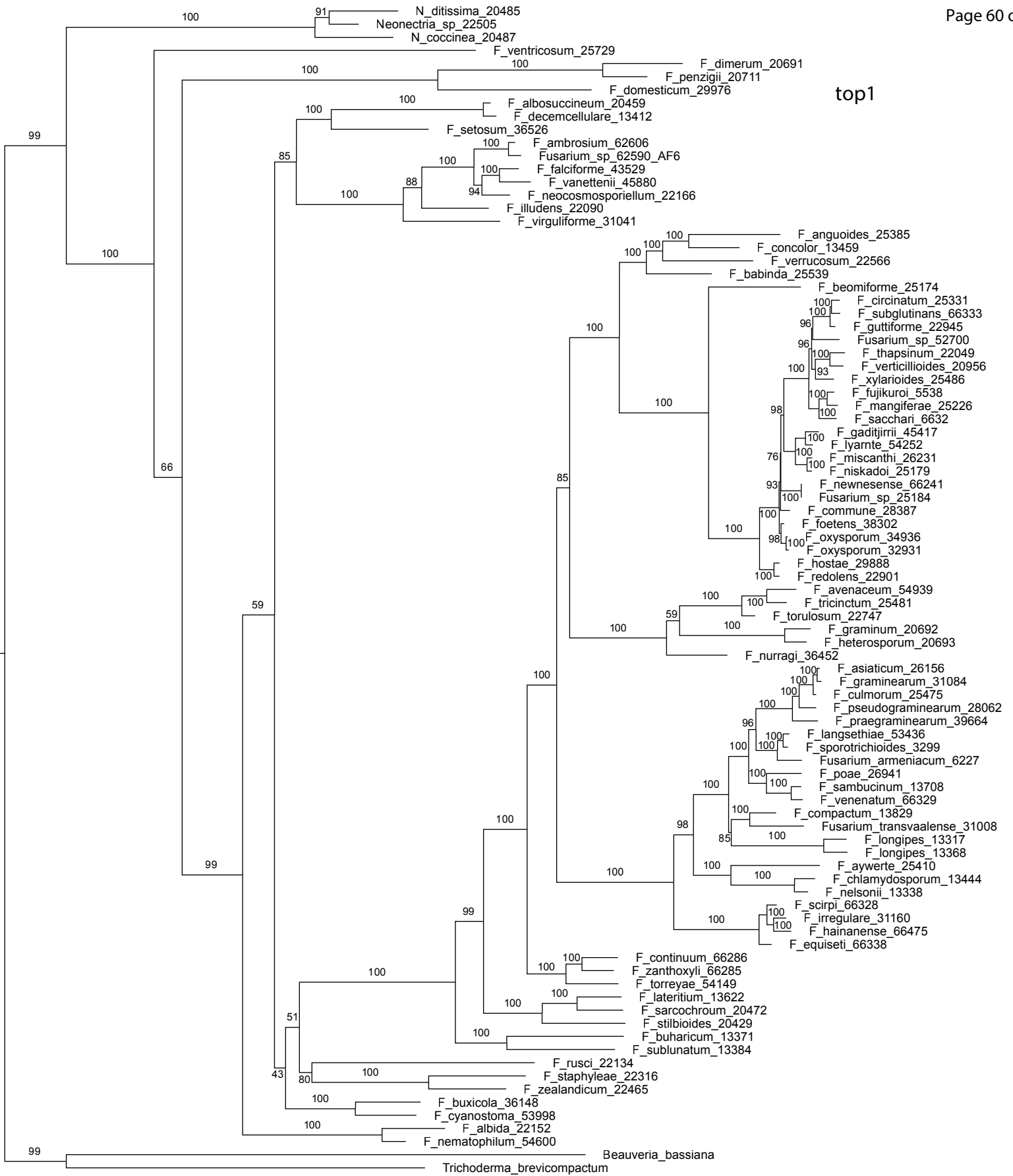

0.07

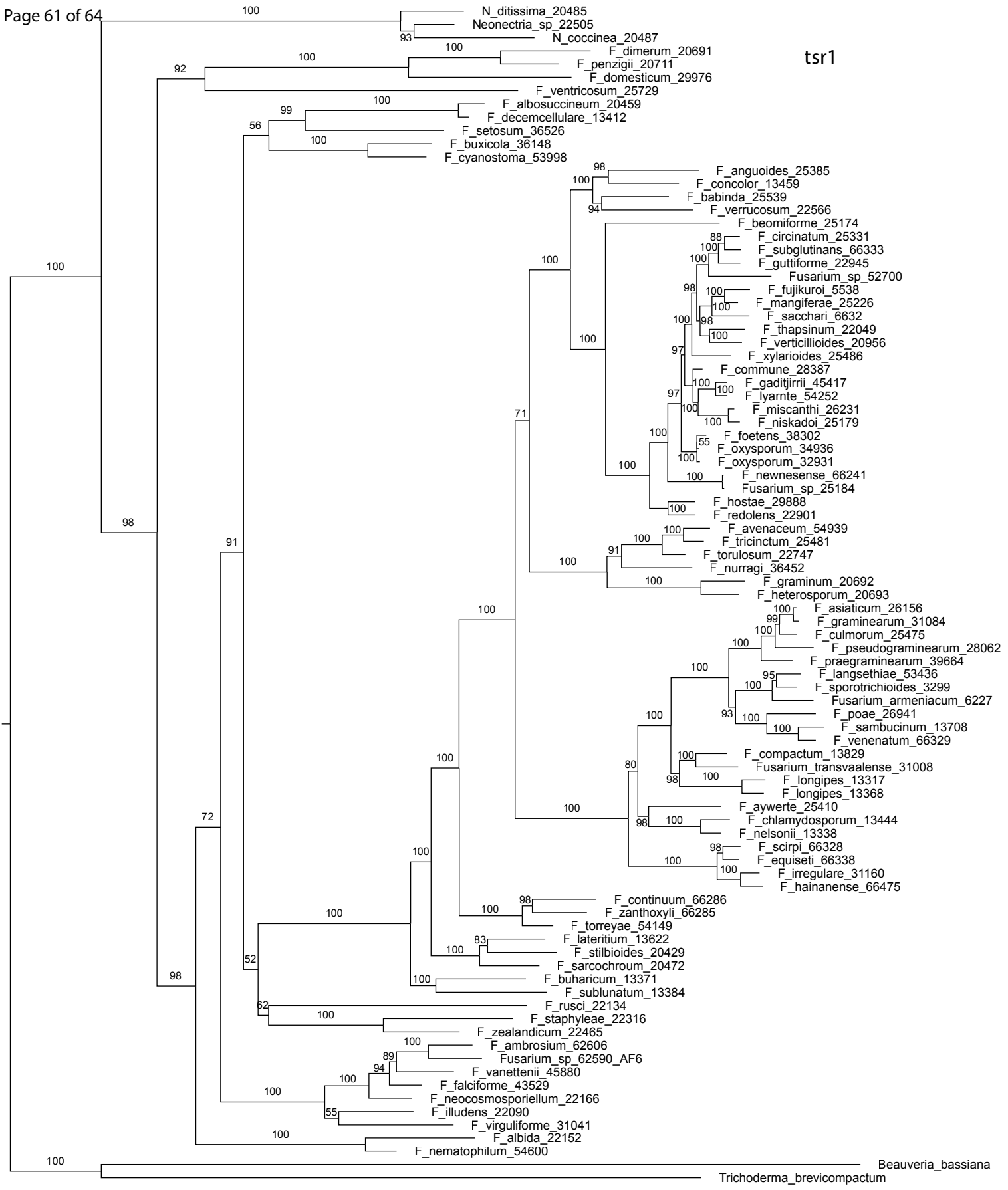

0.08

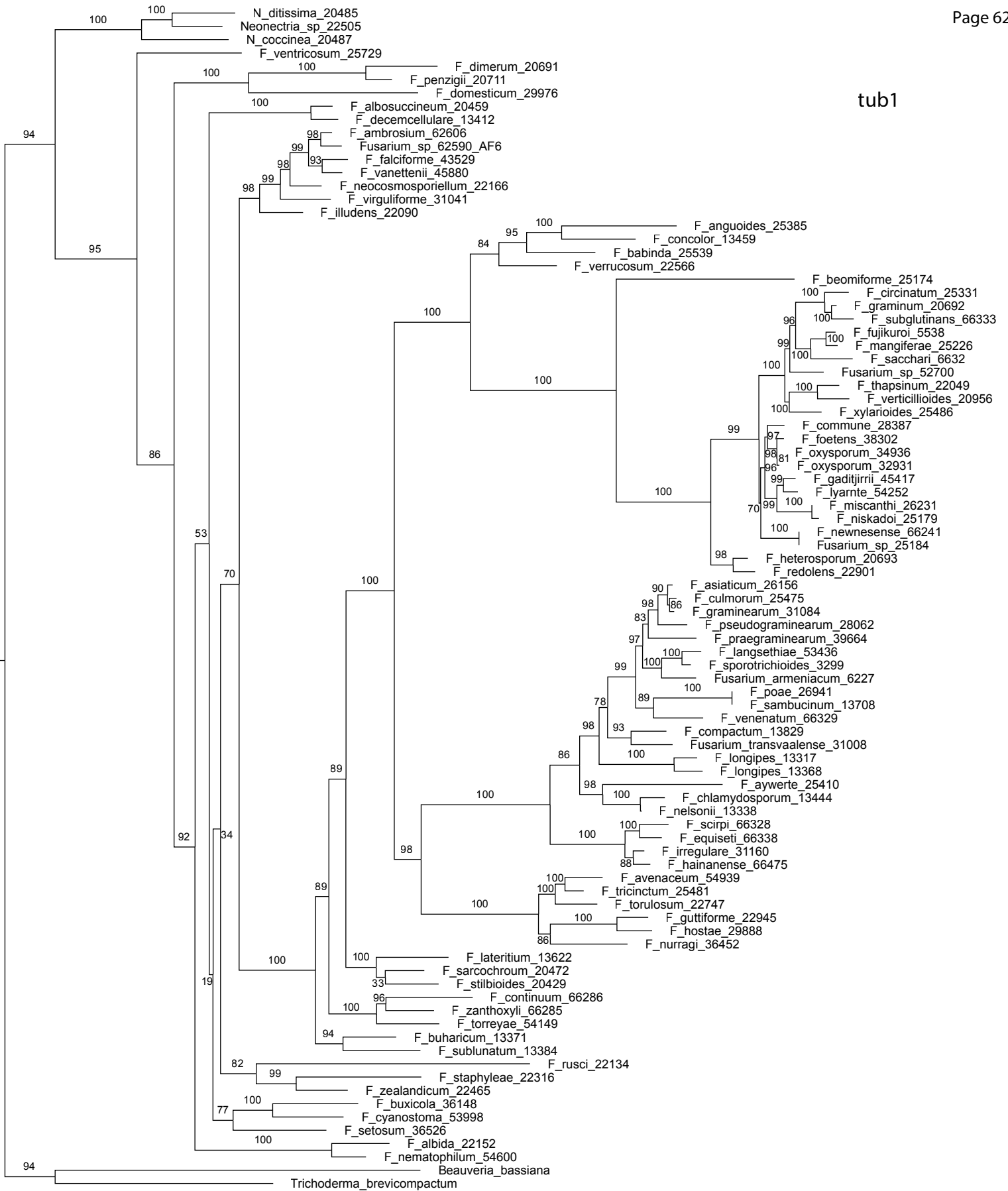

0.03

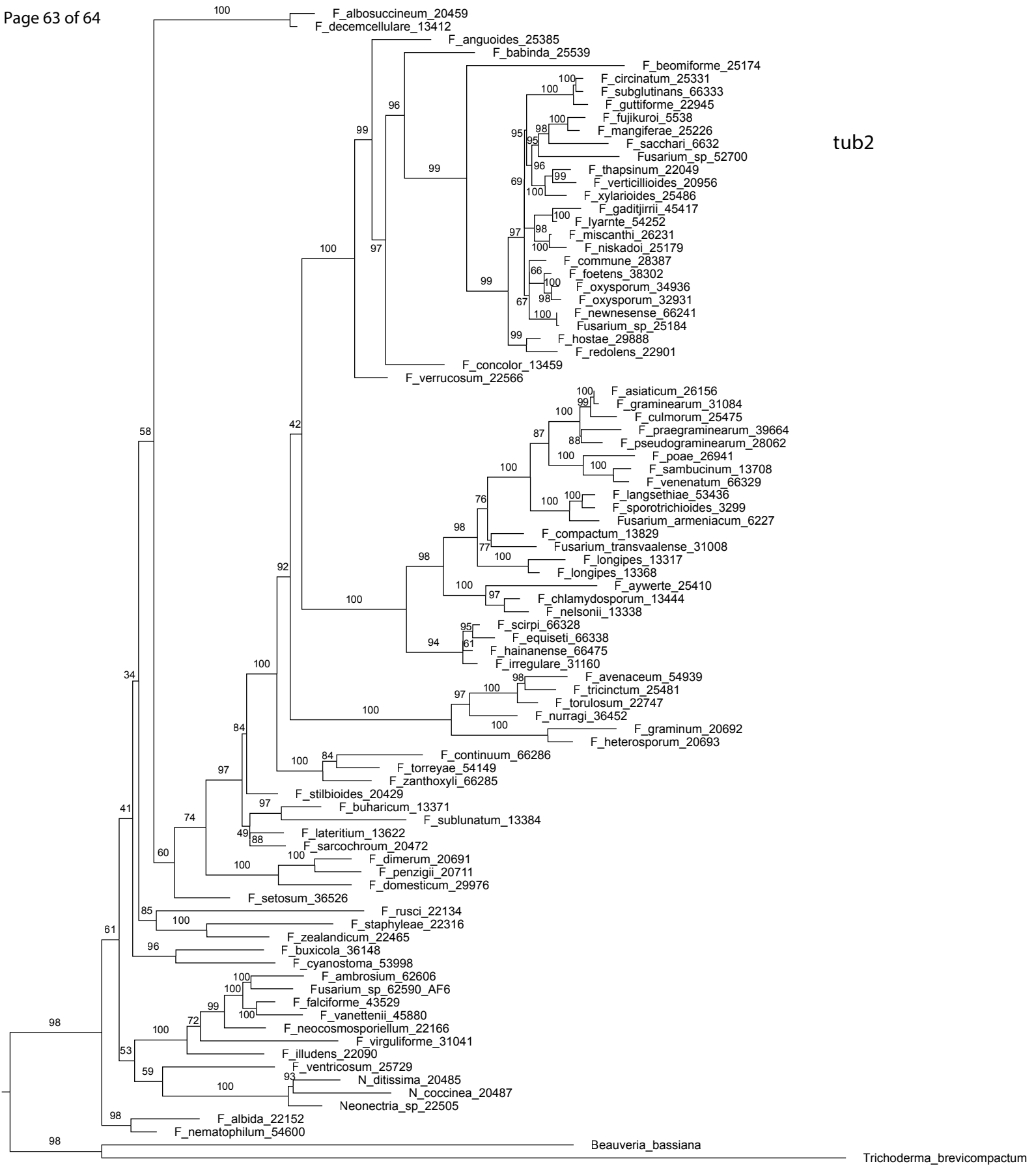

0.03

