



HAL
open science

MOSARH21 future discharges in the French Rhine

Guillaume Thirel, Kai Gerlinger, Charles Perrin, Gilles Drogue, Benjamin Renard, Jean-Pierre Wagner

► **To cite this version:**

Guillaume Thirel, Kai Gerlinger, Charles Perrin, Gilles Drogue, Benjamin Renard, et al.. MOSARH21 future discharges in the French Rhine. General Assembly of the International Commission for the Hydrology of the Rhine basin (CHR), International Commission for the Hydrology of the Rhine basin (CHR), Sep 2020, Online, Switzerland. hal-03277888

HAL Id: hal-03277888

<https://hal.inrae.fr/hal-03277888>

Submitted on 5 Jul 2021

HAL is a multi-disciplinary open access archive for the deposit and dissemination of scientific research documents, whether they are published or not. The documents may come from teaching and research institutions in France or abroad, or from public or private research centers.

L'archive ouverte pluridisciplinaire **HAL**, est destinée au dépôt et à la diffusion de documents scientifiques de niveau recherche, publiés ou non, émanant des établissements d'enseignement et de recherche français ou étrangers, des laboratoires publics ou privés.



➤ MOSARH21 – future discharges in the French Rhine

Coord. and pres.: Guillaume Thirel (Irstea/INRAE)

Contributors: Kai Gerlinger (HYDRON), Charles Perrin (Irstea/INRAE), Gilles Drogue (Univ. Lorraine), Benjamin Renard (Irstea/INRAE) and Jean-Pierre Wagner (DREAL Grand-Est)

Funding: Rhin-Meuse Water Agency (France)

<https://webgr.inrae.fr/en/mosarh21/>

➤ Aims of the MOSARH21 project

Main goal: Producing future discharge estimations for the French tributaries of the Rhine

Sub-goals:

- Adopting a rigorous testing protocol for hydrological models
 - Temporal robustness
- Quantifying uncertainties of the different steps of the modelling chain
 - Several elements used for each step
- Comparing future discharge estimations of MOSARH21 with former projects results
 - CMIP3 vs CMIP5



➤ Hydrological models

Two different approaches

GR5J (semi-distributed)

- Conceptual model
- Sub-basins discretisation
- Daily time step
- 7 parameters, automatic calibration
- Used in Explore 2070

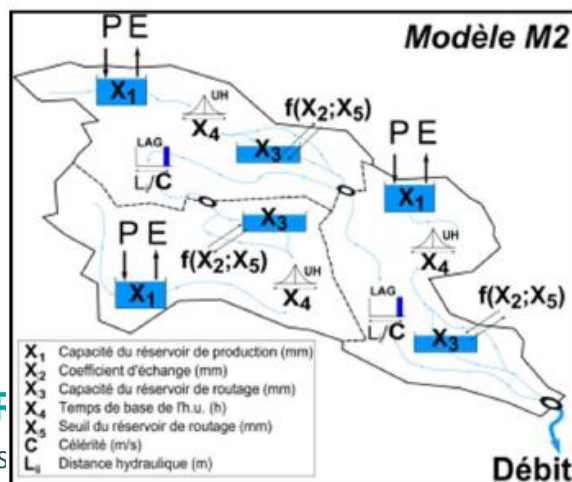

LARSIM water balance model

- Conceptual model
- Grid mesh discretisation
- Daily time step
- 7 parameters, manual calibration, was automatised for MOSARH21
- Used in Flow-MS

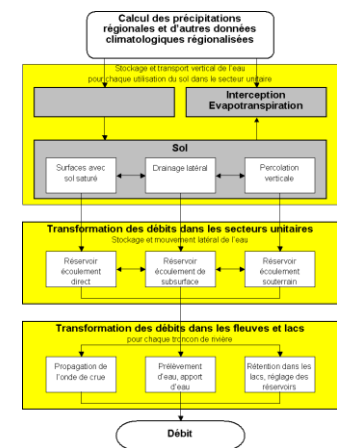
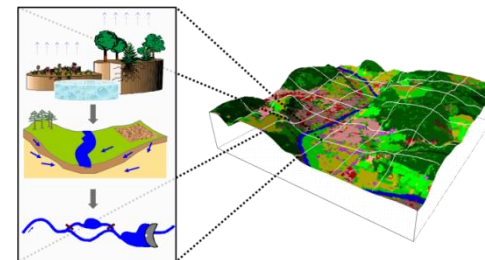

➤ Gauged stations

70 stations

22 of which contain simulations obtained with both models calibrated (category 1)

Observed discharge for all stations

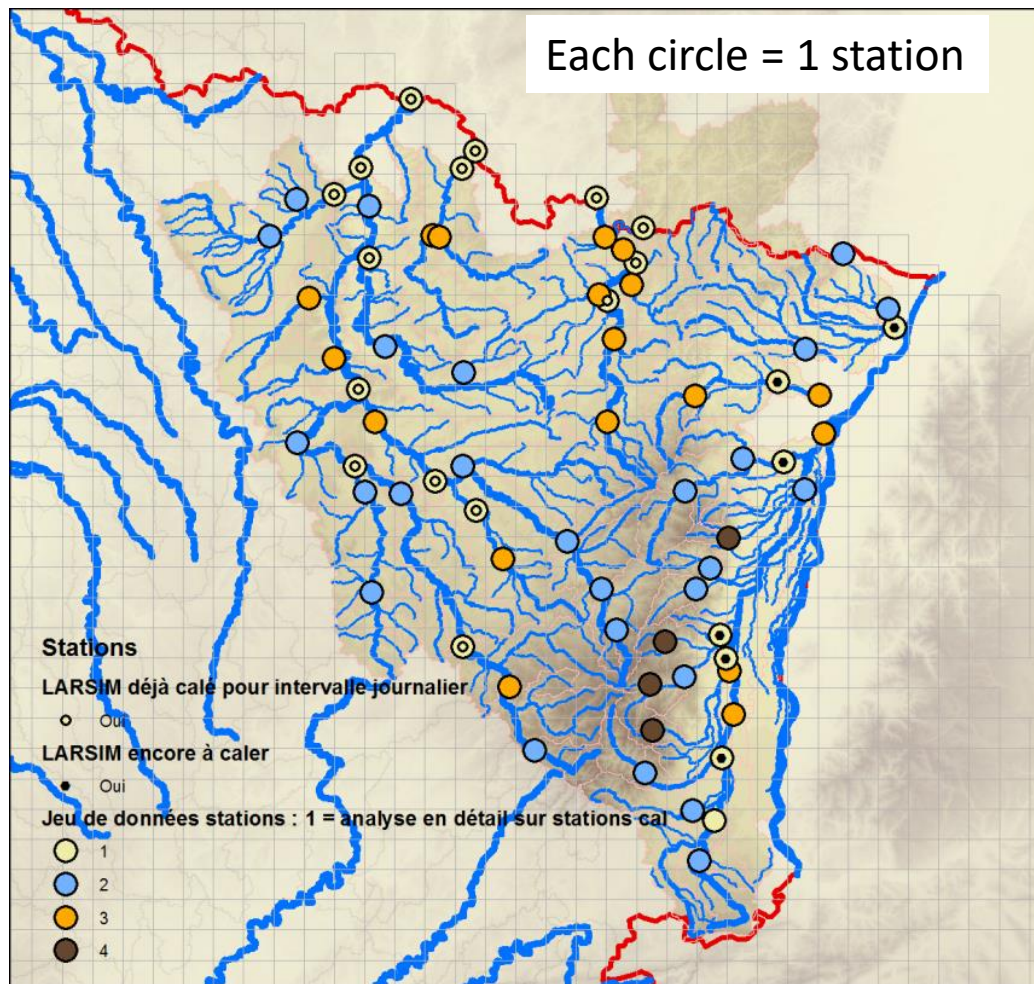

➤ Hydro models parameters calibration

To better suit catchments characteristics

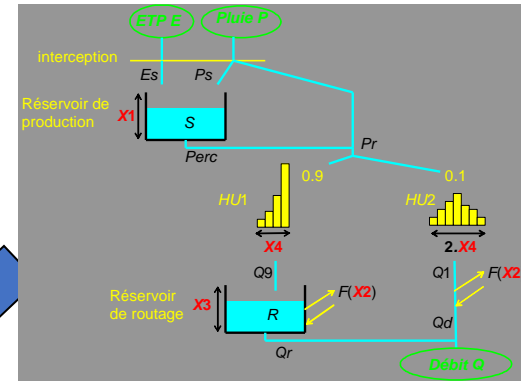
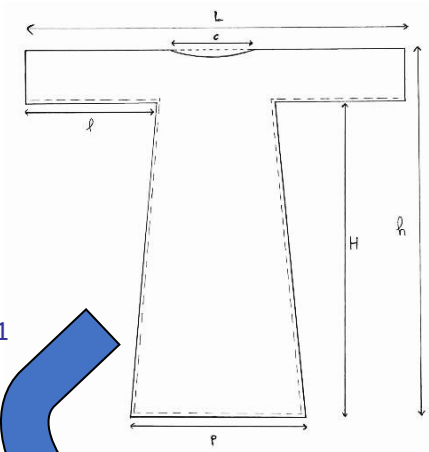

$\{X_1, X_2, X_3, X_4\}_2$

$\{c, l, L, h, H, p\}_1$

$\{c, l, L, h, H, p\}_2$

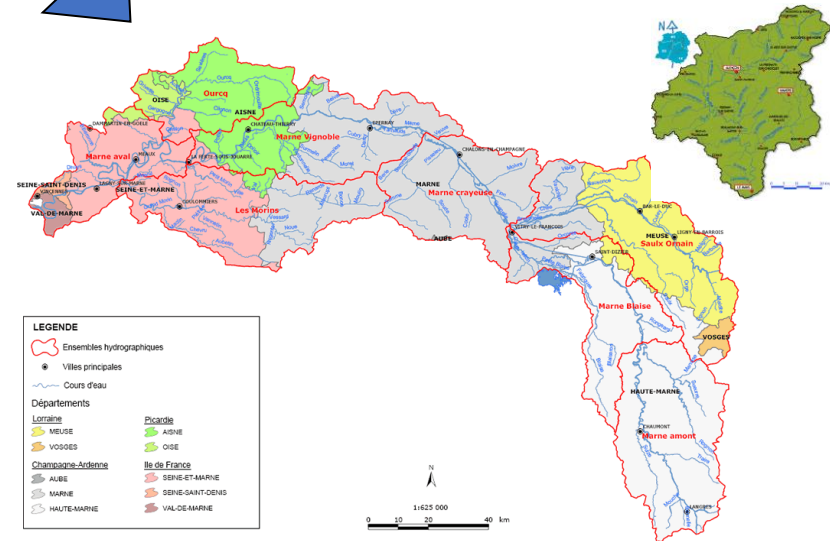

➤ On the temporal robustness of hydro models

Application of a classical split-sample test, a necessity for CC applications (Thirel et al., 2015)

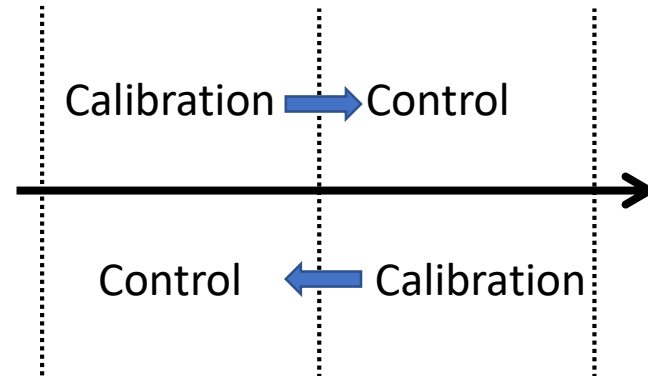
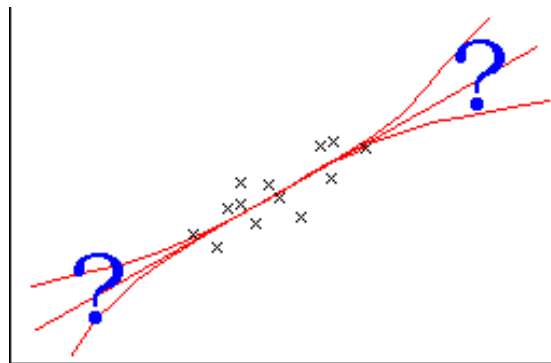
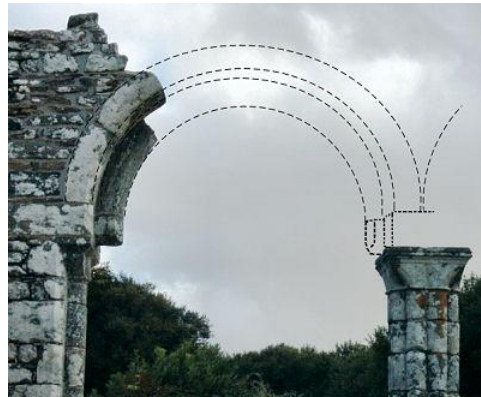

GRSD + LARSIM



INRAE

MOSARH21

24/09/2020 / CHR meeting / Thirel Guillaume (guillaume.thirel@inrae.fr)

Thirel, G., Andréassian, V., Perrin, C., 2015. On the need to test hydrological models under changing conditions. *Hydrological Sciences Journal*, 60:7-8, pages 1165-1173, [DOI:10.1080/02626667.2015.1050027](https://doi.org/10.1080/02626667.2015.1050027).

➤ LARSIM automatic calibration

Based on the GR methodology

First time an automatic calibration of LARSIM was done

7 parameters were selected and calibrated sequentially according to main processes:

- Water balance (1 param)
- Low flows (2 params)
- Mid-flows (2 params)
- High flows (2 params)

For each step, a specific objective function was used



➤ Evolution of performance of LARSIM during its calibration

Holtzheim station

High flows

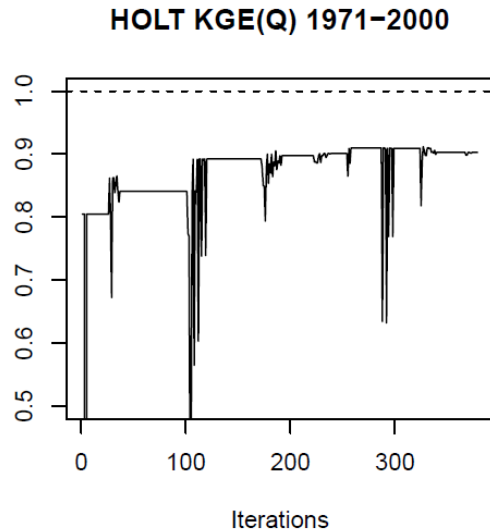

HOLT KGE(sqrt(Q)) 1971-2000

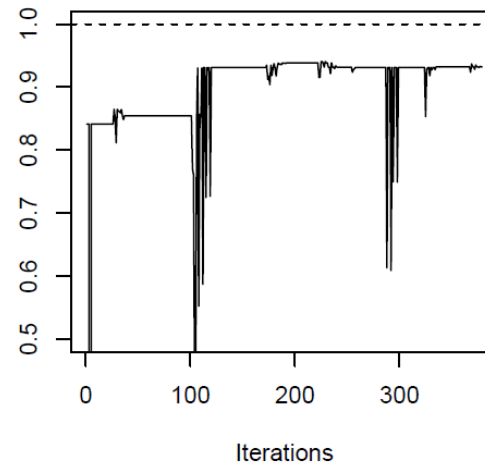

Mid-flows

Low flows

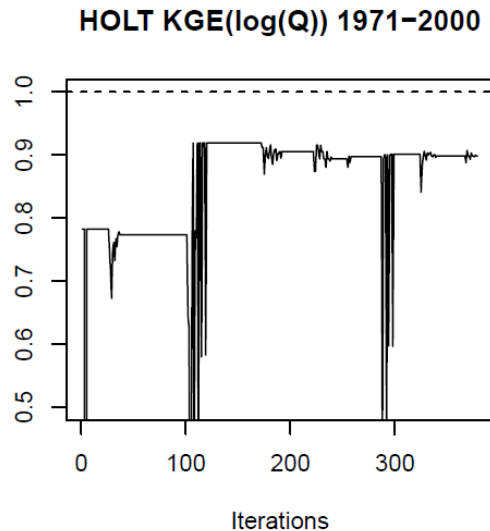

HOLT Balance 1971-2000

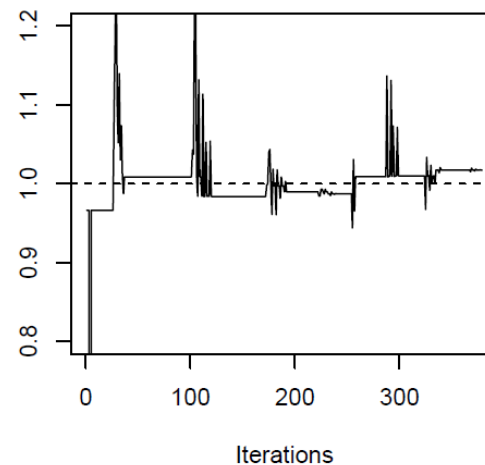

Water balance



INRAE

MOSARH21

24/09/2020 /

➤ Spatial performances

Calibration
(1971-1985)

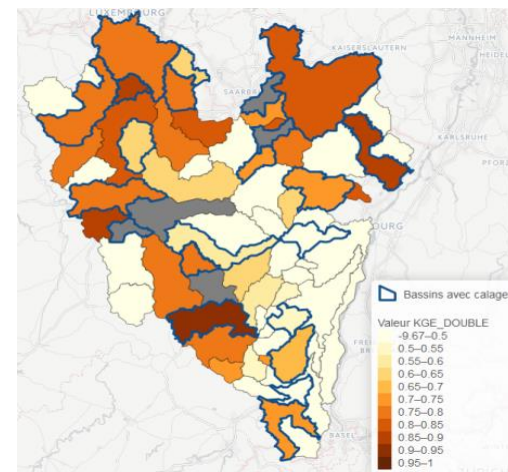
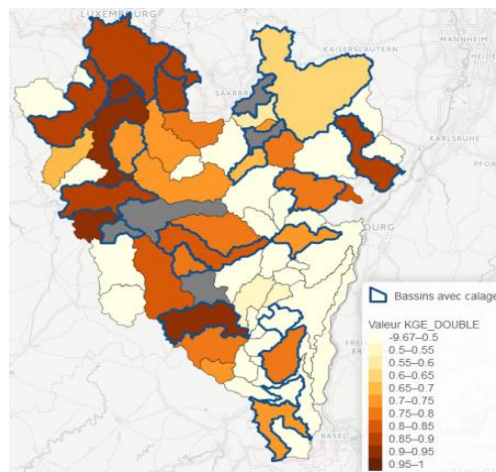
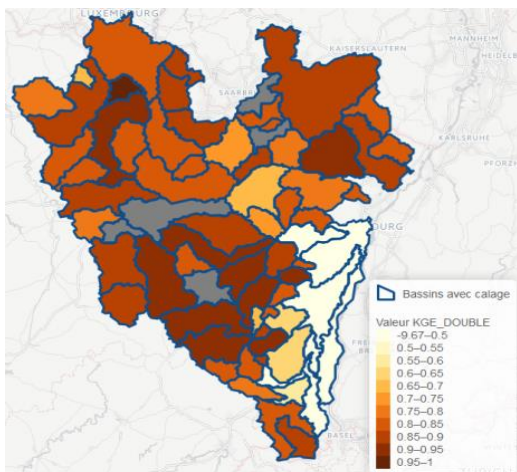

Validation
(1986-2000)

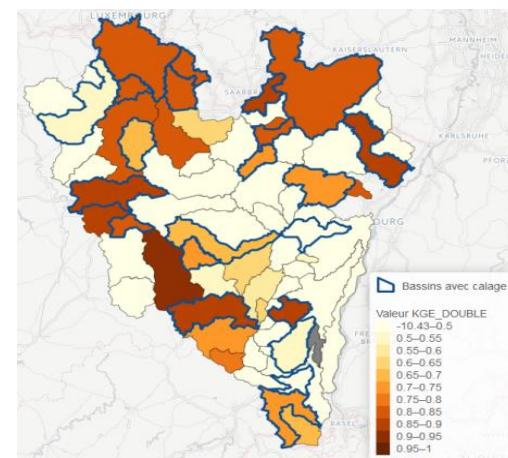
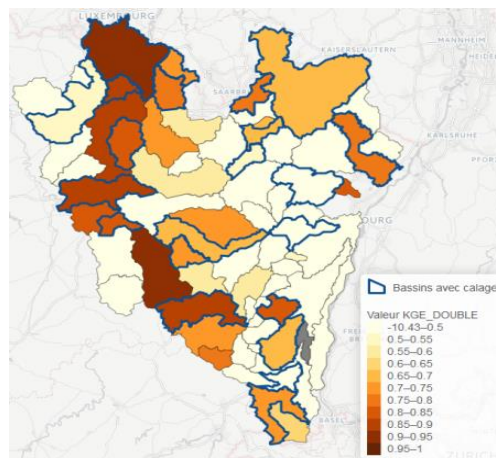
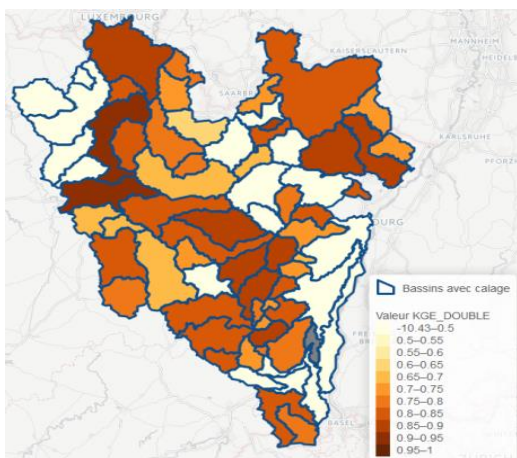

GRSD

LARSIM automatic
calibration

LARSIM manual
calibration



INRAE

MOSARH21

24/09/2020 / CHR meeting / Thirel Guillaume (guillaume.thirel@inrae.fr)

➤ Temporal robustness of hydro models

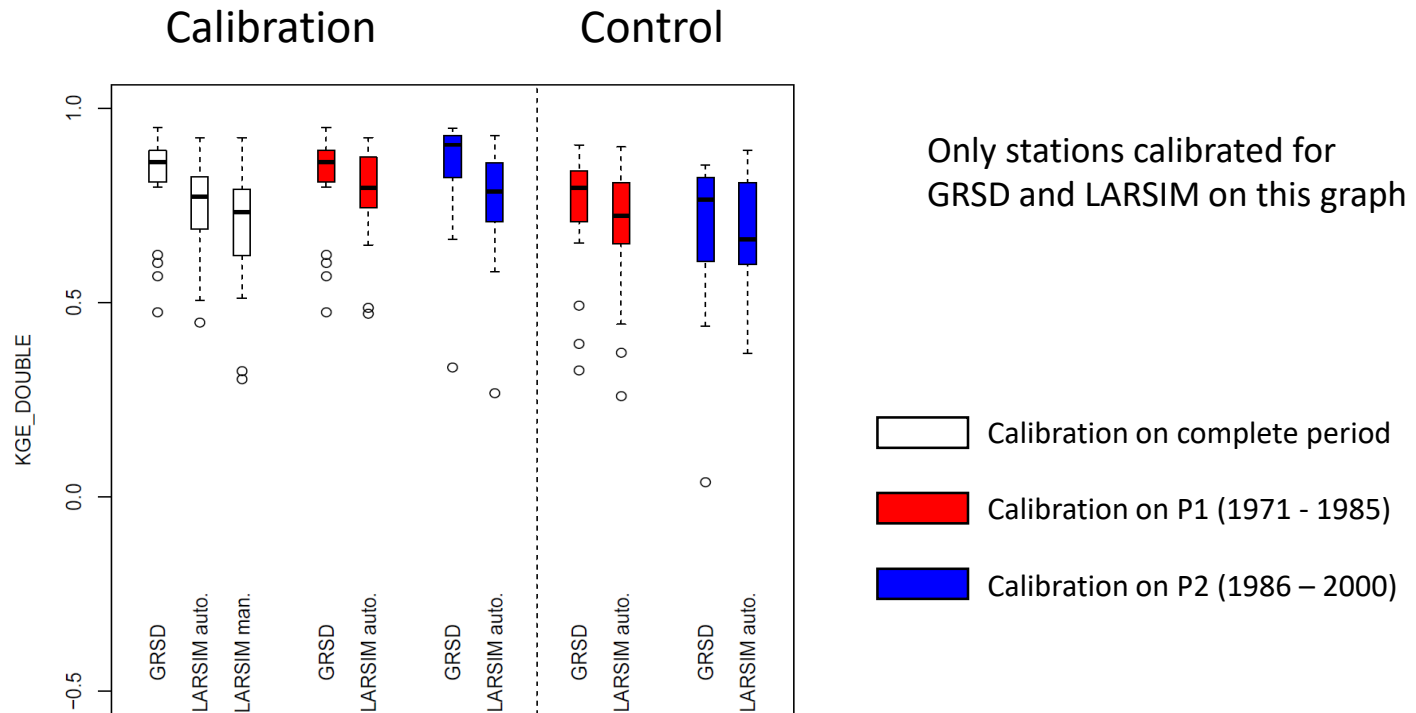

- Slight deterioration of performances on independent periods
- Models seem robust



➤ CC impact modelling chain

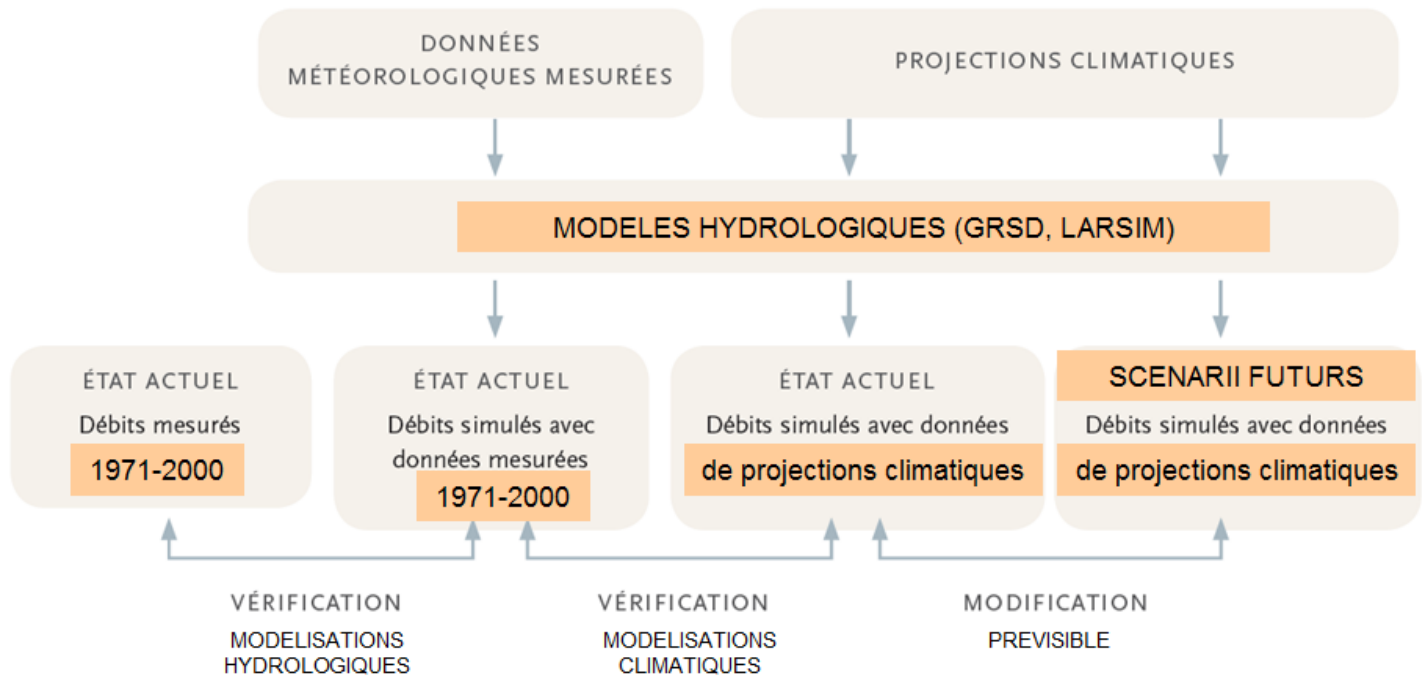
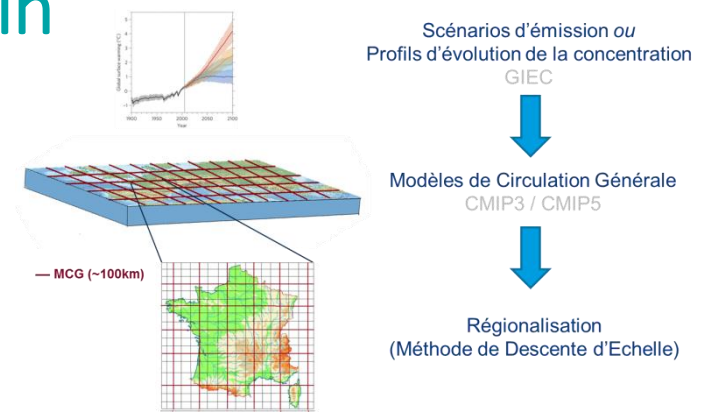

➤ Climate projections used

CMIP3 models, SRES scenarios

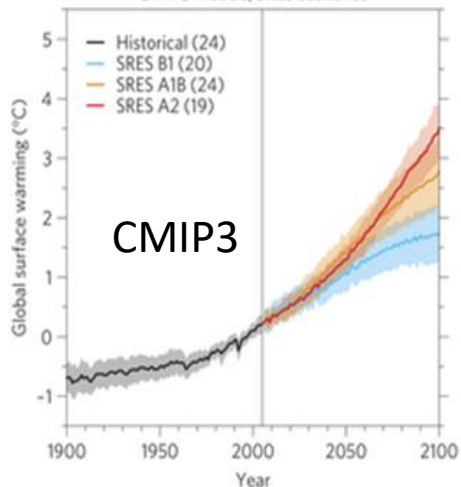

Projet	Rapport du GIEC	Scenarios	GCM	MDE	Débiaisage	GRSD			LARSIM		
						Période PST	Période 1 TFUT	Période 2 TFUT	Période PST	Période 1 TFUT	Période 2 TFUT
<i>Explore 2070</i>	AR4	A1B	CCCMA-CGCM3	SCRATCH08	-	1961-1990	2045-2065	-	1961-1990	2045-2065	-
			ECHAM5-MPI								
			CNRM-CM3								
			GFDL-CM2.1								
			GISS-MODEL-ER								
MRI-CGCM2.3.2											
<i>FLOW-MS Alsace</i>	AR4	A1B	ECHAM5-MPI	COSMO-CLM	linear-scaling	1971-2000	2021-2050	-	1971-2000	2021-2050	-
					quantile-quantile						
<i>FLOW-MS Moselle-Sarre</i>	AR4	A1B	ECHAM5-MPI	COSMO-CLM	linear-scaling	1971-2000	2021-2050	-	1971-2000	2021-2050	-
					quantile-quantile						

CMIP5 models, RCP scenarios

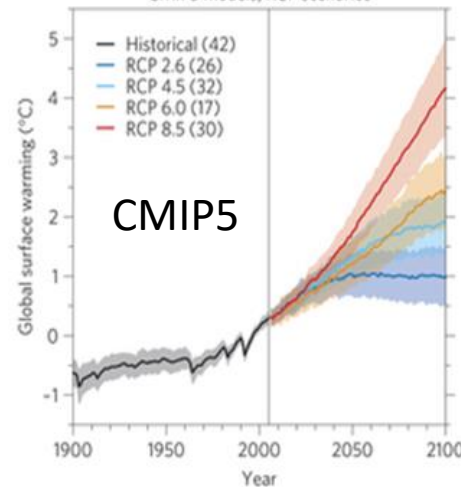

<i>Méthode ADC</i>	AR5	RCP2.5	CNRM-CM5	Advanced Delta Change		1971-2005	2021-2050	2071-2100	-	-	-
		RCP4.5									
		RCP8.5									
		RCP4.5	IPSL-CM5B-LR								
		RCP8.5									
		RCP2.5	GFDL-CM3								
		RCP8.5									
		RCP4.5	GISS-E2-R								
		RCP2.5									
		RCP4.5									
RCP8.5	MRI-CGCM3										
RCP8.5											
<i>Portail DRIAS (CNRM2014 et IPSL2014)</i>	AR5	RCP2.5	CNRM-CM5	Aladin	Quantile-quantile	1971-2000	2021-2050	2071-2100	-	-	-
		RCP4.5									
		RCP8.5									
		RCP4.5	IPSL-CM4								
		RCP8.5									
			WRF	CDFt							

INRAE

MOSARH21

24/09/2020 / CHR meeting / Thirel Guillaume (guillaume.thirel@inrae.fr)

➤ Precipitation projections

Near future

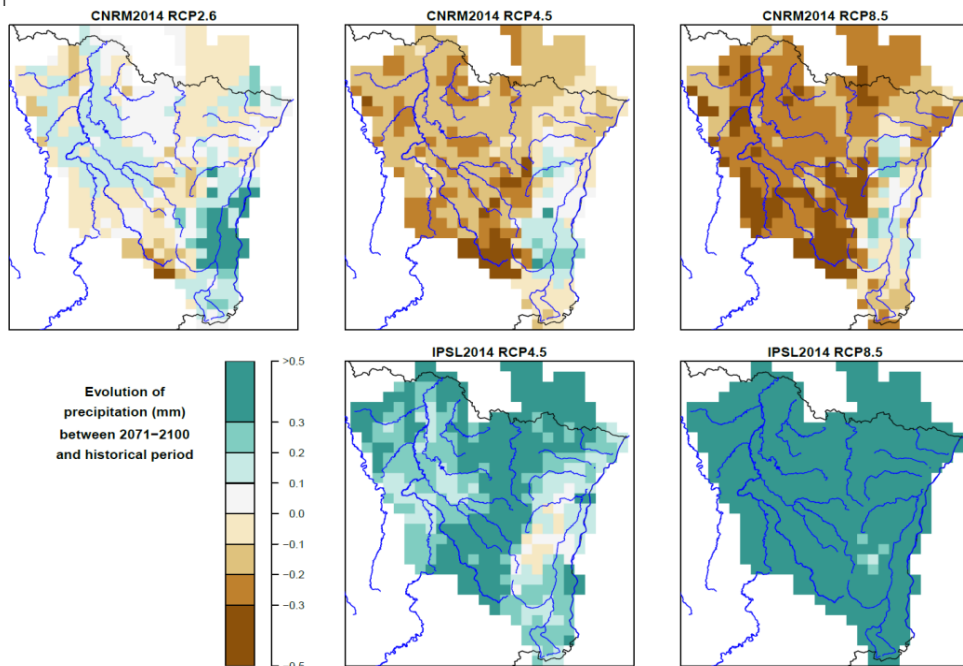
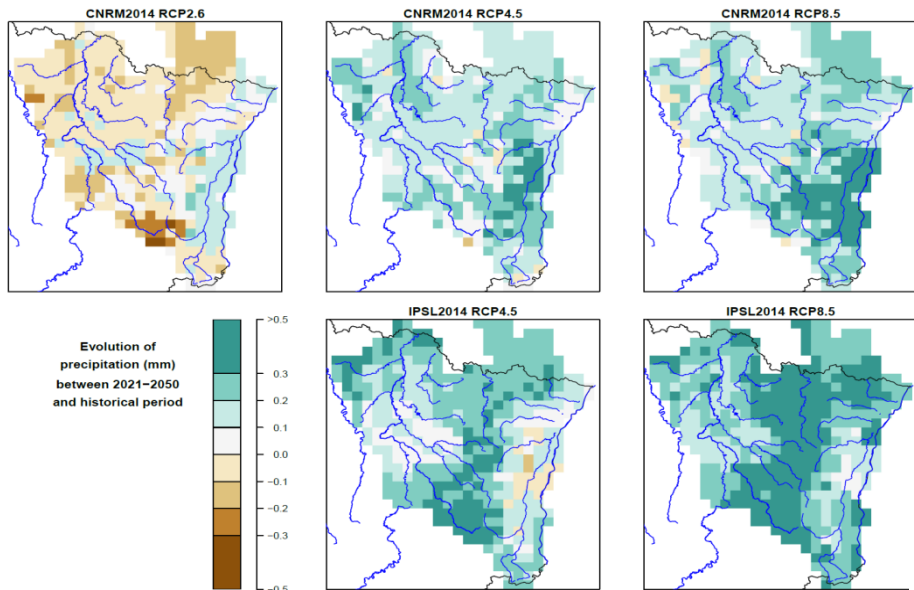

Far future

INRAE

MOSARH21

24/09/2020 / CHR meeting / Thirel Guillaume ([guillaume.thirel](mailto:guillaume.thirel@inrae.fr))

➤ Temperature projections

Near future

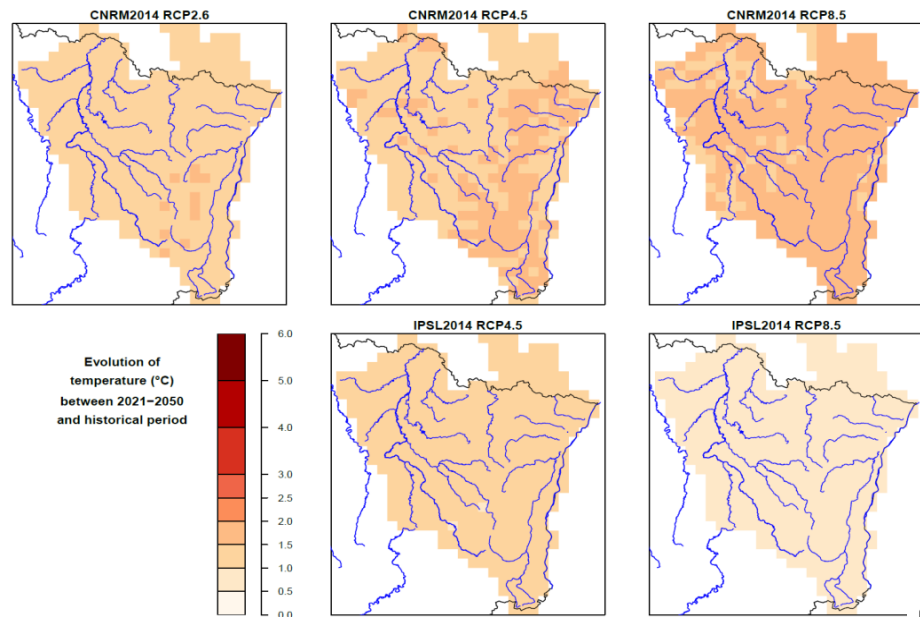

Far future

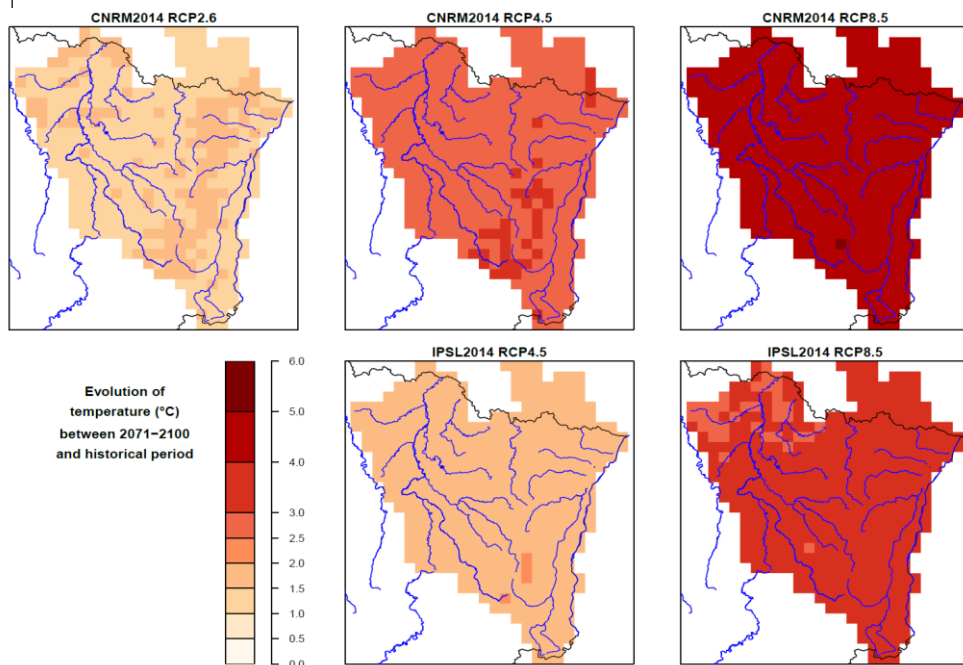

INRAE

MOSARH21

24/09/2020 / CHR meeting / Thirel Guillaume (guillaume.thir)

➤ Hydrological projections (evol. of mean flows in %)

Evolution des débits (%) pour le futur proche (2021–2050) pour toutes les stations

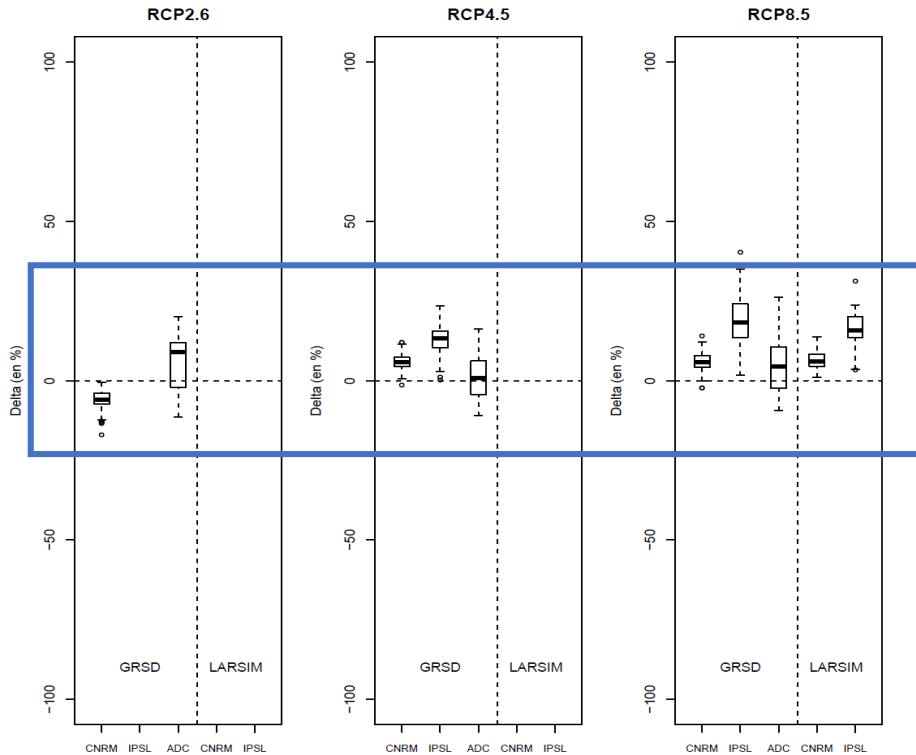

Evolution des débits (%) pour le futur lointain (2071–2100) pour toutes les stations

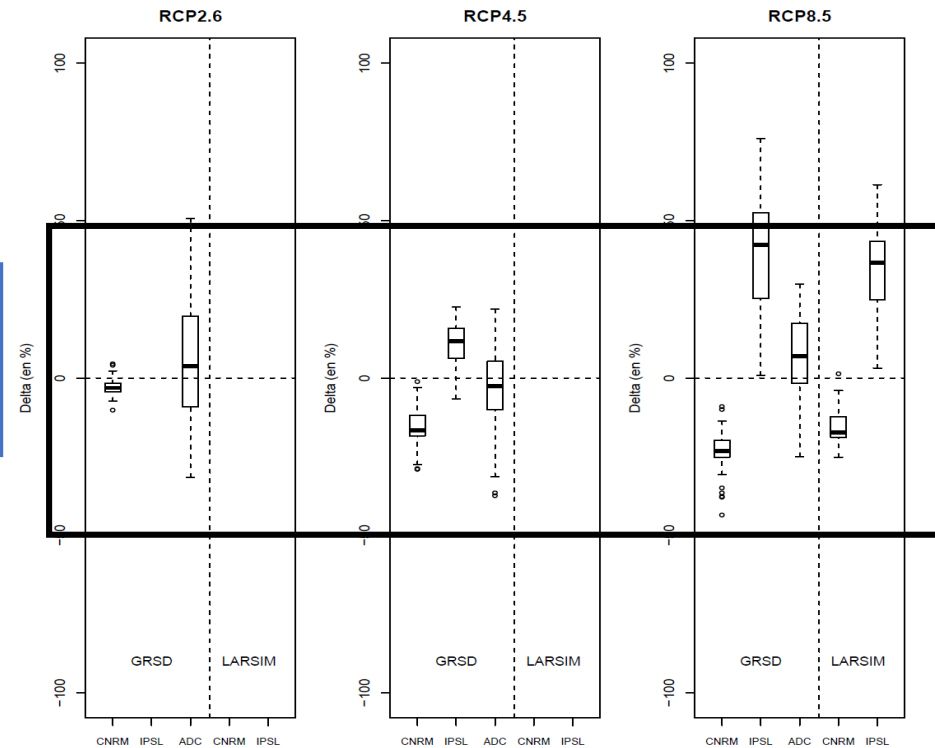

- Low to medium increase of Qmean in near future except RCP2.6
- Contrasted evolution in far future (see climate projections). GRSD behaves more extremely

➤ Hydrological projections (evol. of high flows in %)

Evolution du QJXA10 (%) pour le futur proche (2021–2050) pour toutes les stations

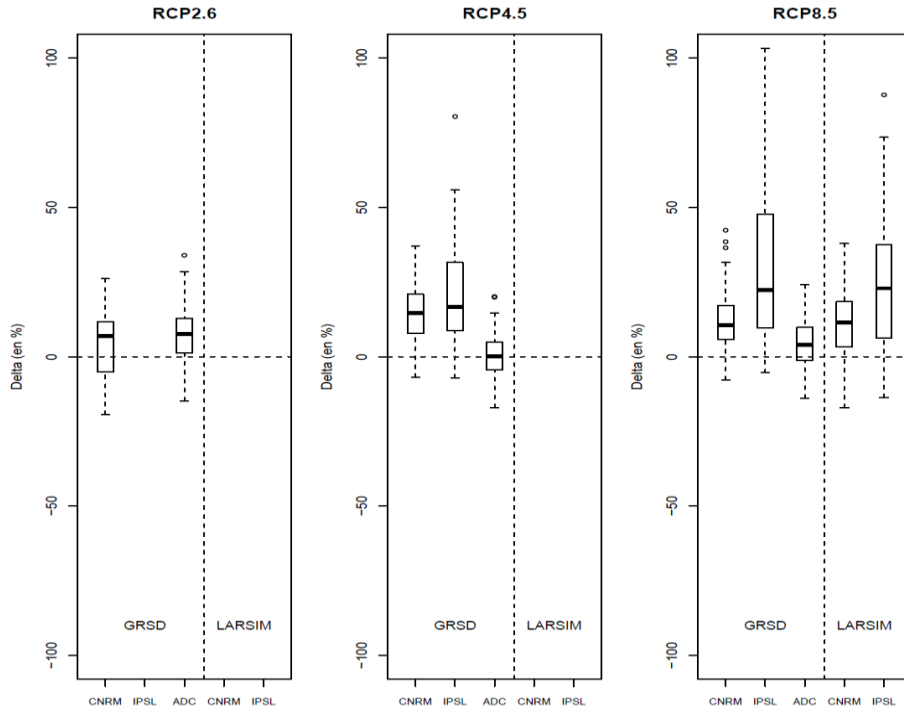

Evolution du QJXA10 (%) pour le futur lointain (2071–2100) pour toutes les stations

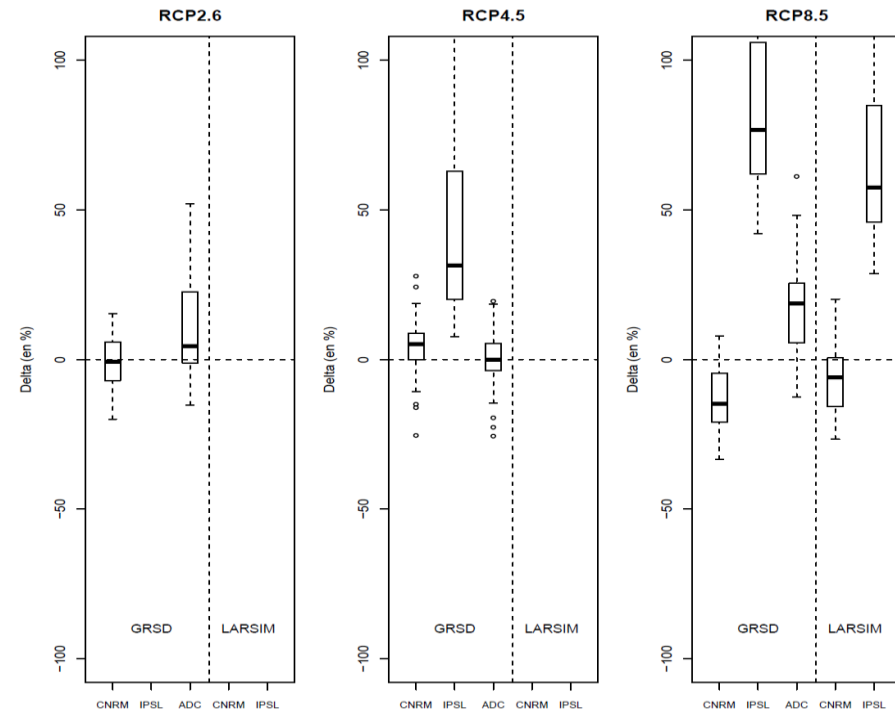

- Low to medium increase of high flows in near future
- Contrasted evolution in far future (see climate projections). GRSD behaves more extremely

➤ Hydrological projections (evol. of low flows in %)

Evolution du QMNA5 (%) pour le futur proche (2021–2050) pour toutes les stations

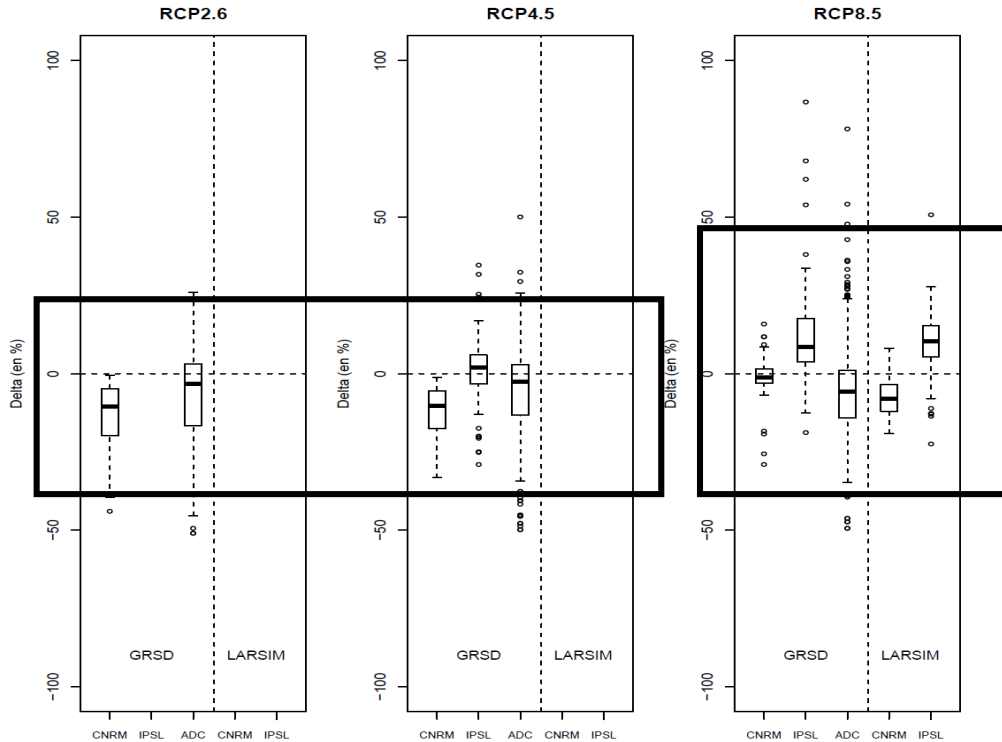

Evolution du QMNA5 (%) pour le futur lointain (2071–2100) pour toutes les stations

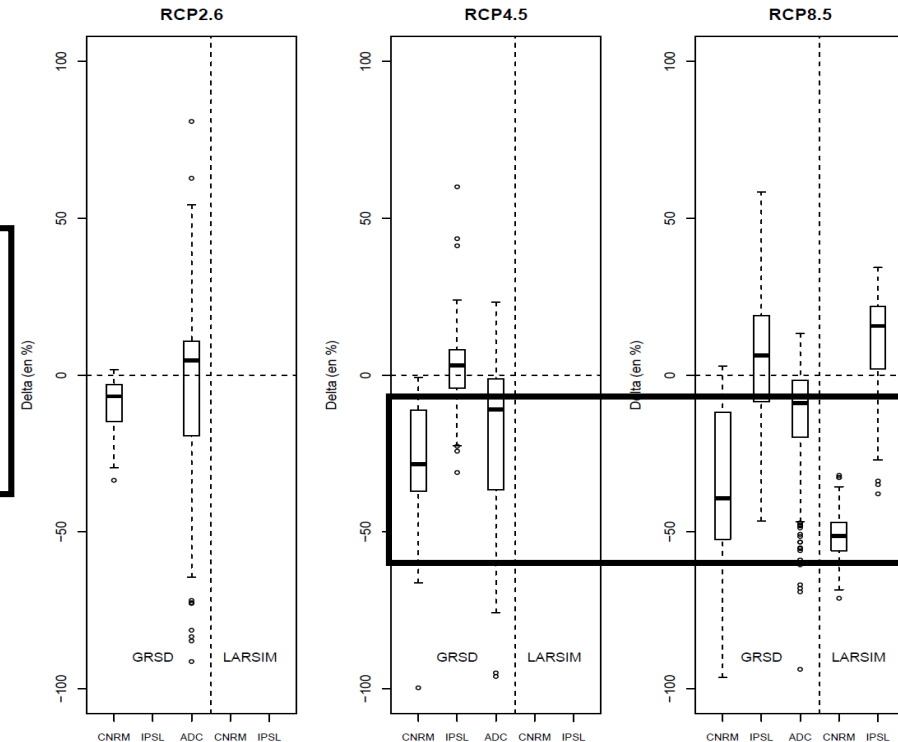

- Low to medium decrease of low flows in near future, except RCP8.5
- Contrasted evolution in far future. Potential very strong decrease for the most pessimistic scenarios



Ordre de grandeur des débits futurs possibles sous les scénarios du cinquième rapport du GIEC, les profils représentatifs d'évolution de concentration (RCP).

Avertissement : ces résultats comportent de très nombreuses incertitudes. Ils sont donnés à titre indicatif. Il ne s'agit pas de prévisions mais d'indications d'évolutions possibles.

Station	Perl (DE)
Rivière	Moselle
Code HYDRO	PERLXXXX
Surface	11556 km ²
Coordonnées Lamb. II (m)	892426, 2504755
Modèles hydrologiques	GRSD, LARSIM
Calage GRSD	Oui
Calage LARSIM	Oui
Période de calage	1971-2000
Période de référence	1971-2000
Période futur proche	2021-2050
Période futur lointain	2071-2100

Fiche crues - Moselle à Perl (DE)

Les évolutions hydrologiques sont calculées entre des simulations de référence en climat présent (1971-2000) et des simulations en climat futur proche (2021-2050) et futur lointain (2071-2100). Différents modèles climatiques désagrégés sont utilisés en forçage des modèles hydrologiques : les modèles du CNRM et de l'IPSL avec désagrégation dynamique, ainsi que de trois à quatre modèles avec désagrégation statistique grâce à la méthode de l'Advanced Delta Change (ADC). Les résultats futurs sont présentés sous forme de deltas entre présent et futur, (FUT-PST)/PST. Les valeurs minimales, médianes et maximales sont calculées pour les scénarios ADC. Selon les stations, les scénarios et les périodes, un ou deux modèles hydrologiques ont été utilisés.

Cette fiche fournit des régimes et des indicateurs hydrologiques liés aux crues. Pour les étiages et le climat, des fiches étiages et climat additionnelles sont disponibles. Le rapport final du projet MOSARH21 donne de plus amples détails sur la méthodologie et la configuration des modèles climatiques et hydrologiques.



Situation de référence (1971-2000)

Régimes et indicateurs des débits observés et simulés sur la période de référence. Tobs indique que les modèles ont été forcés par les observations SAFRAN, Tpst indique que les modèles ont été forcés par les sorties des modèles climatiques. Les débits et indicateurs obtenus avec les scénarios ADC, de par leur construction, sont identiques à Qsim Tobs.

	Jan	Fév	Mars	Avril	Mai	Juin	Juil	Aout	Sept	Oct	Nov	Déc	Annual													
Qobs (m ³ /s)	294.1	293.5	288.3	198.6	130.9	104.6	74.4	49.2	52.7	100.1	155.0	272.6	163.1													
Qsim Tobs (m ³ /s)	271.9	280.4	275.1	280.7	229.6	212.7	177.6	164.1	117.5	114.7	86.5	86.7	60.5	65.5	41.8	48.5	48.3	59.0	105.7	123.6	171.9	200.8	268.4	298.5	154.0	160.7
Qsim Tpst CNRM (m ³ /s)	269.8	288.8	272.8	271.5	259.7	239.2	187.2	168.8	115.1	114.9	95.5	104.6	81.3	97.8	49.5	58.0	57.6	70.7	89.3	106.1	165.8	194.4	184.2	210.0	151.7	159.8
Qsim Tpst IPSL (m ³ /s)	251.9	300.2	224.9	257.9	235.6	252.5	162.4	180.2	124.6	139.5	91.7	108.1	72.2	92.6	46.9	65.0	48.6	71.2	79.3	110.3	155.4	206.2	222.0	288.2	142.7	172.4

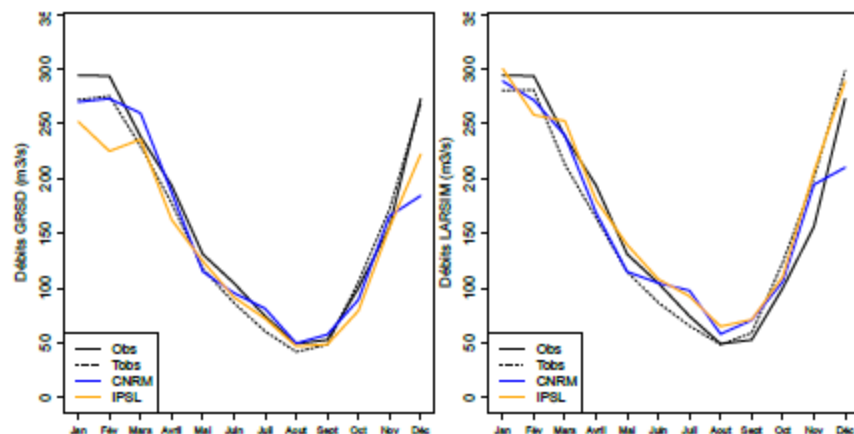

	QJXA2		QJXA10		QJXA100	
Qobs (m ³ /s)	1066.8		1651.4		2880.6	
Qsim Tobs (m ³ /s)	1002.4	930.6	1603.9	1980.3	2354.1	1941.1
Qsim Tpst CNRM (m ³ /s)	931.8	869.3	1442.1	1244.7	2078.6	1712.9
Qsim Tpst IPSL (m ³ /s)	754.1	746.4	1131.0	1069.2	1601.1	1471.9

	Q95		Q99	
Qobs (m ³ /s)	519.0		938.0	
Qsim Tobs (m ³ /s)	494.0	515.6	889.2	913.5
Qsim Tpst CNRM (m ³ /s)	476.3	483.9	836.2	842.6
Qsim Tpst IPSL (m ³ /s)	401.3	460.5	649.4	696.3

➤ Where the hydro projections from Explore 2070 and FLOW MS that different?

Evol. of mean flows in %

Evolution des débits (%) pour le futur proche pour toutes les stations

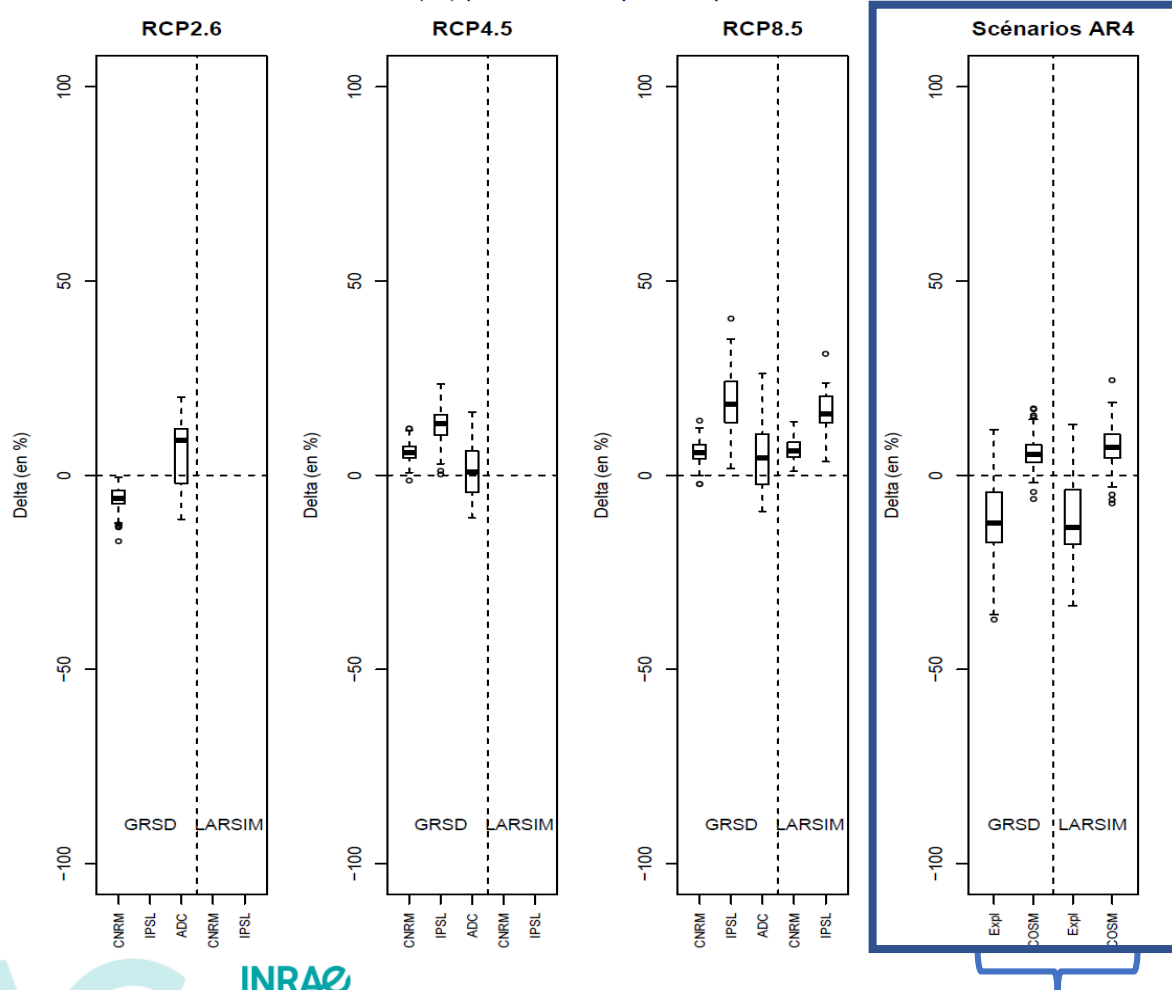

/!\ Beware, the Explore 2070 future period is 2045-2065, not 2021-2050.

FLOW MS rather similar to RCP 4.5

Explore 2070 differs, it is closer to far future of MOSARH 21 evolutions!

➤ Where the hydro projections from Explore 2070 and FLOW MS that different?

Evol. of High flows in %

Evolution du QJXA10 (%) pour le futur proche pour toutes les stations

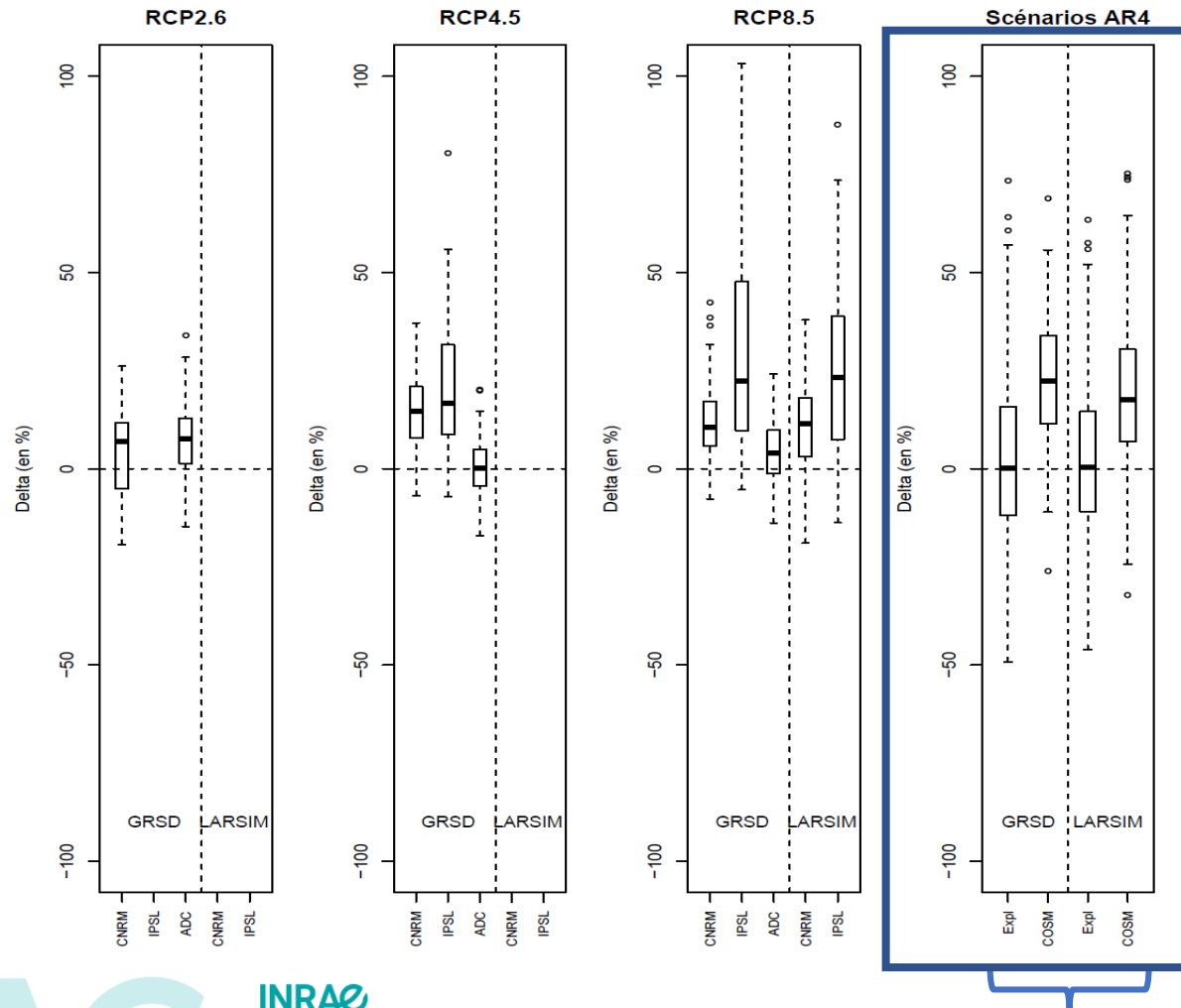

FLOW MS rather similar to RCP 8.5

Explore 2070 more uncertain, it is closer to far future of MOSARH 21 evolutions!



➤ Where the hydro projections from Explore 2070 and FLOW MS that different?

Evol. of low flows in %

Evolution du QMNA5 (%) pour le futur proche pour toutes les stations

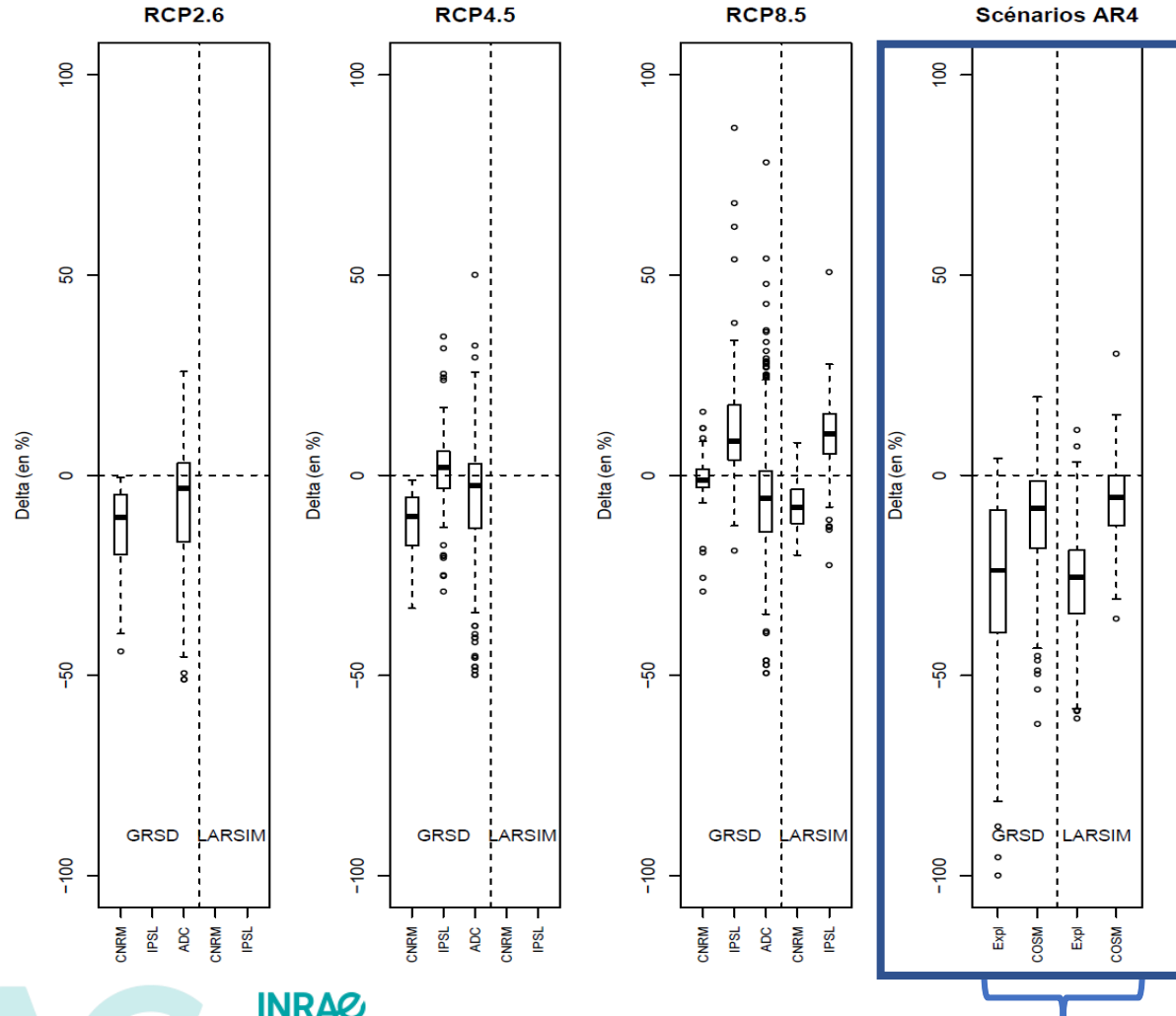

FLOW MS rather similar to CNRM and ADC projections

Explore 2070 more pessimistic, it is closer to far future of MOSARH 21 evolutions!



> Conclusions

- We updated the hydro projections of Mosel, Sarre and French Rhine
- We took into account uncertainties
- We undertook an automatic calibration of LARSIM

- Mean flows should slightly increase (except IPSL RCP 8.5)
- High flows should increase in near future, more uncertainty later
- Low flows should decrease in near future, more uncertainty later but potential very high decrease

- Uncertainties: GCMs > RCPs > Sampling > Hydro models

- Prior studies: with CMIP5, we globally are consistent with FLOW MS or Explore 2070, but:
 - Explore 2070 corresponds rather to an intermediate state between MOSARH 21 near and far futures
 - FLOW MS cannot be linked to a specific RCP