



HAL
open science

Use of Mixture Dosing and Nonlinear Mixed Effect Modeling of Eight Environmental Contaminants in Rabbits to Improve Extrapolation Value of Toxicokinetic Data

Véronique V. Gayrard-Troy, Jessika Moreau, Nicole Picard-Hagen, Virginie Helies, Philippe Marchand, Jean-Philippe Antignac, Pierre-Louis Toutain, Roger Leandri

► **To cite this version:**

Véronique V. Gayrard-Troy, Jessika Moreau, Nicole Picard-Hagen, Virginie Helies, Philippe Marchand, et al.. Use of Mixture Dosing and Nonlinear Mixed Effect Modeling of Eight Environmental Contaminants in Rabbits to Improve Extrapolation Value of Toxicokinetic Data. *Environmental Health Perspectives*, 2021, 129 (11), pp.117006. 10.1289/EHP8957 . hal-03497113

HAL Id: hal-03497113

<https://hal.inrae.fr/hal-03497113>

Submitted on 5 Jan 2022

HAL is a multi-disciplinary open access archive for the deposit and dissemination of scientific research documents, whether they are published or not. The documents may come from teaching and research institutions in France or abroad, or from public or private research centers.

L'archive ouverte pluridisciplinaire **HAL**, est destinée au dépôt et à la diffusion de documents scientifiques de niveau recherche, publiés ou non, émanant des établissements d'enseignement et de recherche français ou étrangers, des laboratoires publics ou privés.

Public Domain

Use of Mixture Dosing and Nonlinear Mixed Effect Modeling of Eight Environmental Contaminants in Rabbits to Improve Extrapolation Value of Toxicokinetic Data

Véronique Gayrard,¹ Jessika Moreau,^{1,2} Nicole Picard-Hagen,¹ Virginie Helies,³ Philippe Marchand,⁴ Jean-Philippe Antignac,⁴ Pierre-Louis Toutain,^{5,6} and Roger Leandri^{1,2}

¹ToxAlim (Research Center in Food Toxicology), Université de Toulouse, INRA, ENVT, INP-Purpan, UPS, Toulouse, France

²Médecine de la Reproduction, Hôpital Paule de Viguier, Centre Hospitalier Universitaire de Toulouse, Toulouse, France

³GenPhySE, INRA, Université de Toulouse, INPT, ENVT, Castanet Tolosan, France

⁴Oniris, INRAE, LABERCA, Nantes, France

⁵INTHERES, Université de Toulouse, INRA, ENVT, Toulouse, France

⁶The Royal Veterinary College, University of London, London, UK

BACKGROUND: Although *in vivo* studies of internal exposure to hazardous substances have been carried out for many years, there is room for progress to improve their informative value while adhering to the four R's: replacement, reduction, refinement, and responsibility rule.

OBJECTIVES: The objective of the study was to illustrate how toxicokinetic (TK) study design and data analysis can be implemented under the 4R rule to plan a chronic dosage regimen for investigating TK/toxicodynamic (TD) relationships.

METHODS: The intravenous (IV) and oral serum concentrations of eight hazardous environmental contaminants including 1,1-Dichloro-2,2-bis(p-chlorophenyl)ethylene (pp'DDE), β -Hexachlorocyclohexane (β -HCH), hexachlorobenzene (HCB), 2,2',4,4'-tetrabromodiphenyl ether (BDE-47), perfluorooctane sulfonate (PFOS), perfluorooctanoic acid (PFOA), di(2ethylhexyl)phthalate (DEHP), and bisphenol S (BPS) were obtained after mixture dosing in rabbits using a sparse sampling design. Data were comprehensively analyzed using nonlinear mixed effect (NLME) modeling.

RESULTS: The short persistence of BPS and of the DEHP metabolite (mono-2-ethylhexyl phthalate), reflected by their mean residence times (MRT) of a few hours, was due to their efficient clearance (CL, 3.2 and 0.47 L/kg/h). The longer MRT of the other compounds (1–48 d) resulted either from their extremely low clearance (lower than 0.01 L/kg/h for PFOA and PFOS) or from their very large volume of distribution (V_{SS}) ranging from 33 to 45 L/kg. Estimates of CL, V_{SS} , and bioavailability were used to compute the oral loading and daily maintenance doses required to attain a nominal steady-state serum concentration of 1 ng/mL. Simulations with the NLME model were applied to predict the serum concentration profile and to contrast the differential rates of accumulation in the central vs. peripheral compartments.

CONCLUSION: NLME modeling of the IV and oral TK of hazardous environmental contaminants, in rabbits while fulfilling the 4R rule, was able to provide the physiological basis for interspecies extrapolation of exposure rates in a TK/TD approach to risk assessment. <https://doi.org/10.1289/EHP8957>

Introduction

Measuring *in vivo* exposure to xenobiotics for all relevant human scenarios is not feasible, and minimizing the number of animals involved in regulatory toxicology is an ethical priority (Tannenbaum and Bennett 2015). This dual constraint has led to the promotion of several alternative nonanimal approaches in the field of risk assessment for the prediction of toxicity in humans (Höfer et al. 2004). These approaches are collectively known as New Approach Methodologies (NAMs) and are based on applying “read-across” to predict end-point information for one substance (the target substance) by using data from the same end point from (an)other substance(s), [the source substance(s); Ball et al. 2020; Benfenati et al. 2019; Dimitrov and Mekenyan 2010]. Despite the sophistication of these NAMs, traditional animal-based testing is still of value and continues to play an important role in toxicology. Recently we demonstrated, using an *in vivo*

pig model, that the oral bioavailability of bisphenol S (BPS), which is structurally closely related to bisphenol A (BPA) and promoted as a substitute, was about 100 times higher than that of BPA (Gayrard et al. 2019). It can thus be deduced, at least regarding toxicokinetics (TK), that BPA cannot be used indiscriminately as a source substance for all other bisphenols in a “read-across” prediction. Nevertheless, given the necessary objective to reduce and optimize animal testing, there is still room for the improvement of experimental designs, data analysis, and results interpretation in these *in vivo* approaches. In our opinion, routine TK tests are frequently designed to meet regulatory requirements rather than to maximize their informational value, the data analyses being generally simplistic and typically based on noncompartmental analysis (NCA). Furthermore, interpretation of the results relates more to descriptive variables of exposure, namely maximal concentration (C_{max}), time to C_{max} and area under the concentration–time curve (AUC), than to primary parameters with direct physiological significance, such as clearance or volume of distribution at steady-state (V_{SS}), that are more amenable to interspecies extrapolation (Sharma and McNeill 2009). For example, the intravenous (IV) route is the only one able to unambiguously generate TK parameters such as clearance (CL) and V_{SS} and to measure an absolute bioavailability (Benet and Zia-Amirhosseini 1995) but is nevertheless rarely used. One reason is the difficulty of analyzing the data when sufficiently large samples cannot be obtained from the same animal (rich sampling) due to body size limitations (e.g., rodents) or when animals are sampled destructively. However, modeling approaches able to simultaneously manage unbalanced and sparse data from different animals or even from different trials do exist, such as nonlinear mixed effect (NLME) modeling (Li et al. 2015). Although it was introduced in TK more than 20 y ago (Burtin

Address correspondence to Véronique Gayrard, UMR1331 Toxalim, Ecole Nationale Vétérinaire de Toulouse, Laboratoire de Physiologie, 23 chemin des Capelles, BP 87614, 31076 Toulouse CEDEX 3, France. Email: veronique.gayrard@envt.fr

Supplemental Material is available online (<https://doi.org/10.1289/EHP8957>).
The authors declare that they have no actual or potential competing financial interests.

Received 13 January 2021; Revised 5 October 2021; Accepted 20 October 2021; Published 17 November 2021.

Note to readers with disabilities: *EHP* strives to ensure that all journal content is accessible to all readers. However, some figures and Supplemental Material published in *EHP* articles may not conform to 508 standards due to the complexity of the information being presented. If you need assistance accessing journal content, please contact ehponline@niehs.nih.gov. Our staff will work with you to assess and meet your accessibility needs within 3 working days.

et al. 1996), NLME modeling requires in-depth knowledge of the modeling process and has rarely been applied. Finally, a factual rather than mechanistic interpretation of the results could be favored in a strictly regulatory context to minimize the risk of the evaluators raising new questions to which the tenderers do not wish to answer.

The present study was aimed to illustrate how a sparse sampling design and conduct of animal studies (mixture approach), advanced data analysis using NLME modeling, and a reasoned data interpretation can reduce and optimize animal testing and be integrated into the overall rationale of NAMs. These concepts were investigated by performing a kinetic evaluation of a mixture of eight environmental contaminants. This TK assay constituted the first phase of a larger project to document, in female rabbits, the TK/toxicodynamic (TD) relationship between the systemic exposure to a mixture of environmental contaminants and their reproductive toxicity. More specifically, the goal was to determine the doses (loading and daily maintenance doses) to be administered by oral route to ensure immediate and subsequent maintenance of serum concentrations of the eight substances at a level suitable for TK/TD approaches to risk assessment. These compounds were selected for their widespread occurrence in the environment and their potential threat to human health (see for review Gentry et al. 2011; Mrema et al. 2013; Pelch et al. 2019; Sunderland et al. 2019; Wu et al. 2020). They were also representative of different classes of chemicals including polybrominated diphenyl ether [2,2',4,4'-tetrabromodiphenyl ether (BDE-47)], perfluorinated alkyl substances with perfluorooctane sulfonate (PFOS) and perfluorooctanoic acid (PFOA), phthalate esters [di(2-ethylhexyl)phthalate (DEHP)], bisphenols (BPS), and organochlorines with 1,1-Dichloro-2,2-bis(p-chlorophenyl)ethylene (pp'DDE), a breakdown product of DDT [1,1,1-trichloro-2,2-bis(p-chlorophenyl)ethane], β -Hexachlorocyclohexane (β -HCH) a by-product in the manufacturing of lindane and hexachlorobenzene (HCB). Organochlorine pesticides/herbicides such as DDT, HCH, and HCB have been extensively used to control insect-borne diseases and agricultural pests. Although these chemicals have been banned in most countries, they still persist in the environment (WHO 2003) and remain of concern for human health mainly due to their chemical stability and bioaccumulation in living organisms (Geyer et al. 1986; Keswani et al. 2021). Concerns for BDE-47 have also arisen because it was proven to be one of the dominant congeners of polybrominated diphenyl ether detected in the environment and human tissues (Wu et al. 2020). Despite their phaseout, PFOA and PFOS (the two most widely known perfluorinated alkyl substances) remained widely distributed in the environment and human samples due to their persistence and bioaccumulation capability (Calafat et al. 2007; Knutsen et al. 2018). One of the main BPA substitutes, BPS, was widely found in the environment throughout the world (Qiu et al. 2019). Extensive use of DEHP as a plasticizer in manufacturing a wide variety of consumer products, such as packed food and beverages, has led to its ubiquitous presence in the environment and human exposure (Gao and Wen 2016; Wang et al. 2019). Because the conversion of DEHP into mono(2-ethylhexyl) phthalate (MEHP) is considered to be a critical factor in the toxicity of DEHP, MEHP exposure was regarded as relevant in terms of risk assessment (Gentry et al. 2011).

Due to the widespread occurrence of these contaminants in the air, soils, and water, the ingestion of contaminated food and beverages was assumed to be a major route of exposure (Gasull et al. 2011; Haug et al. 2011; Serrano et al. 2014; Wu et al. 2018, 2020). Even though a large number of studies have reported prevalent systemic human exposure to all the above-selected pollutants (Bjerregaard-Olesen et al. 2017; Ettinger et al. 2017; Johns et al. 2017; Lee et al. 2017; Lewin et al. 2017; Philips et al. 2018;

Robinson et al. 2015; Tamayo-Uria et al. 2019; Wilson et al. 2018; Woods et al. 2017), TK data remain scarce. Our approach, based on a simultaneous TK assessment of these contaminants, using mixture dosing and a nonlinear mixed effect model, allowed simultaneous analysis of sparse sampling data from the time profiles of environmental contaminants serum concentrations after IV and oral route administrations and provided robust estimates of the mean TK parameters. A preliminary study was performed to check the ability of these parameters to predict the oral and maintenance doses required to attain targeted serum steady-state concentrations in female rabbits.

Methods

Animals

The experiment was authorized by the French Ministry of Research under the number APAFIS No. 14787-201804201607003 v3. Only female rabbits were used because this work was a preliminary step in the FEDEXPO research project of which one goal is to study the consequences of chronic exposure to a complex mixture of environmental chemicals on the female reproductive system, notably ovarian function. The rabbits were housed individually in inox cages. A sample of drinking water and of the unique batch of commercial feed (Stabifibre), used during the course of the TK assay and supplied *ad libitum*, were analyzed to assess possible residual concentrations of the test compounds. The room was illuminated by artificial 12:12 h light:dark cycle, and the temperature was maintained at about 18°C.

Experimental Design and Dosing

TK assay. The experiment was carried out on thirty 10-wk old female New Zealand white rabbits (INRA 1777 line) weighing 2.37 ± 0.14 kg. Twelve rabbits received a mixture of the 8 compounds by IV route, and a mixture of the same compounds was administered by oral route to 12 other rabbits, except that DEHP instead of MEHP was administered orally. Blood samples were taken at the designated time points post IV and oral administration: 15 min, 30 min, 1 h, 2 h, 4 h, 8 h, 12 h, 24 h, 3 d, 7 d, and 28 d from groups of 3 or 6 rabbits at each sampling time. Each rabbit was sampled 3 times and 3 rabbits were sampled at each sampling time, except at 30 min post administration, when 6 samples were collected to provide a sufficient blood volume for assaying the compounds. The doses and assay time points were selected to allow the calculation of TK parameters (Table 1) based on preliminary TK data. Residual concentrations of the compounds, and their possible evolution over time, were determined by sampling six entirely untreated rabbits during the TK study on the day of drug administrations, then 14 d and 28 d later.

Chronic exposure. The objective of this preliminary experiment was to check the ability of our approach to determine the loading and maintenance doses of the eight compounds to be administered simultaneously by oral route to reproduce in female rabbits targeted serum concentrations. The experiment was carried out on thirty-two 2-wk old female New Zealand white rabbits (INRA 1777 line) randomly allocated to a treatment and control groups of 16 rabbits weighing 309 ± 45 g and 298 ± 62 g, respectively. The treated rabbits were orally administered a mixture of the eight compounds at a dosage corresponding to the sum of the loading and daily maintenance doses followed by daily administrations of the maintenance dose for 17 wk (see the "Estimation of the doses" section). The control group was orally administered the vehicle for the same duration. At 19 weeks of age, blood was collected immediately *ante mortem* from the

treated and control rabbits weighing 4.028 ± 0.564 kg and 4.070 ± 0.393 kg, respectively.

Test Material, Treatments, and Blood Sampling

All materials for the preparation of solutions, including the materials used for sampling, processing, and analysis, were made of glass or polypropylene. BDE-47 (2,2',4,4'-tetrabromodiphenyl ether) and HCB (hexachlorobenzene) were purchased from Toronto Research Chemicals. BPS, pp'DDE, DEHP, β HCH, MEHP, PFOA, and PFOS potassium salt were purchased from Sigma-Aldrich. Based on quantification using a linear isomer of PFOS (nPFOS) as standard, the PFOS isomer profile of the Sigma standard used for dosing, indicated that the branched PFOS (brPFOS) isomer content (39%) was of the same order as that determined in human serum (27%–44%; Beesoon et al. 2011).

For the TK study, the IV dosing solution was prepared by dissolving together BDE-47, BPS, pp'DDE, β -HCH, MEHP, PFOA, and PFOS in DMSO at the measured respective concentrations of 48, 26, 7, 4.4, 12, 0.82, and 0.94 mg/mL while an oily emulsion containing 0.13 mg of HCB per milliliter (corn oil:lecithin:Ringer solution, 10:0.5:89, vol:wt:vol) was prepared. The oral dosing solution was prepared by dissolving together BDE-47, BPS, pp'DDE, DEHP, HCB, β -HCH, PFOA, and PFOS in corn oil containing 3% of ethanol at the measured respective concentrations of 2.9, 1.1, 1.1, 2.8, 1.9, 0.5, 0.1, and 0.09 mg/mL. The volume administered was adjusted to the animal's body weight (BW) recorded the day before.

Intravenous administrations were performed via an indwelling catheter (22G Terumo, 0.9×25 mm) just after its insertion into an ear vein. Immediately after administration of the solution containing all compounds (0.1 mL/kg) except HCB, the emulsion containing HCB (0.5 mL/kg) was slowly injected. For oral administrations, the mixture of all compounds (4 mL/kg) was deposited directly in the mouth of rabbits using a catheter (22G BD Insyte 22G, 0.9×25 mm). Prior to the study, the rabbits had been trained to gradually swallow water and then corn oil.

Blood samples were collected from the auricular artery using a 20 G needle (0.9×25 mm) and a dry tube. The first two blood samples were 8–10 mL in volume, whereas a large volume (about 20 mL) was obtained *antemortem* immediately after electrical stunning (95LX rabbit stunner; Burdis), followed by exsanguination.

For the chronic exposure, the first-day dosing solution (loading plus maintenance doses, 4 mL/kg) was prepared by dissolving together BDE-47, BPS, pp'DDE, DEHP, HCB, β -HCH, PFOA, and PFOS in corn oil containing 20% of ethanol at the respective concentrations of 2.5, 38.5, 287, 258, 46, 44, 4.9, and 14 μ g/mL. The maintenance dosing solution was prepared by dissolving together BDE-47, BPS, pp'DDE, DEHP, HCB,

β -HCH, PFOA, and PFOS in corn oil containing 5% of ethanol at the respective concentrations of 1.1, 122, 96, 770, 5.6, 10, 10, and 1.0 μ g/mL. The volume of the maintenance dosing solution (1 mL/kg) was weekly adjusted to the mean BW estimated from the known pattern of growth of the INRA 1777 rabbit line. Oral dosing and *antemortem* blood sampling were performed as previously described.

Blood samples were left to clot for about 20–30 min at ambient temperature and centrifuged for 20 min at $3,000 \times g$ at 25°C. The separated serum was stored in glass tubes at -20°C until assayed.

Sample Analysis

Serum analysis. The assay time points are given in Table 1. Four concurrent quantifying methods were performed to analyze BPS/MEHP, BDE-47, pp'DDE/HCB/ β HCH, and PFOA/PFOS, respectively, using liquid chromatography–tandem mass spectrometry (LC-MS/MS) measurement for perfluorinated compounds (PFAS; Cariou et al. 2015), GC-HRMS measurement for polybromodiphenylether (PBDE) compounds (BDE-47; Antignac et al. 2009) and gas chromatography–tandem mass spectrometry (GC-MS/MS) measurement, on one hand for organochlorine pesticides (OC; Bichon et al. 2015) and on the other hand, bisphenols and phthalates with detailed conditions described elsewhere (Decueinck et al. 2015, 2019). Serum concentrations of BPS (total and unconjugated), MEHP, PFOA, and PFOS were also evaluated in the samples collected from control rabbits on the day of drug administrations and 14 d later. The serum concentrations of BDE-47, HCB, and β -HCH were evaluated in the samples collected from control rabbits 28 d after the administrations.

Briefly, for BDE and OC analysis, formic acid was added to 200 μ L of serum samples before extraction of the compounds with a mixture of hexane/dichloromethane (80/20 vol/vol). ^{13}C -labeled internal standards (Wellington Laboratories) were added to the samples before the extraction step (^{13}C -BDE-47, ^{13}C -pp'DDE, ^{13}C -HCB, ^{13}C - β HCH). BDE-47 was detected by GC-EI(+)-HRMS (7890, Agilent Technologies/JMS800D, $R = 10,000$, Jeol), using a DB 5MS capillary column ($30 \text{ m} \times 0.25 \text{ mm}$, $0.25 \mu\text{m}$, J&W Scientific). Organochlorine pesticides (pp'DDE, HCB and β HCH) were separated and detected by GC-EI(+)-MS/MS (Agilent Technologies 7890 gas chromatograph coupled with an Agilent 7010 triple quadrupole mass spectrometer) using an HT8-PCB capillary column ($60 \text{ m} \times 0.25 \text{ mm}$, $0.25 \mu\text{m}$, TRAJAN). Analytes were identified by two unique diagnostic signals [multiple reaction monitoring (MRM) transitions] and quantified based on the most intense signal.

For PFOA and PFOS, 400 μ L of serum was spiked with ^{13}C -labeled standard ($^{13}\text{C}_4$ -PFOA and $^{13}\text{C}_4$ -PFOS) before being extracted using a mixture of methanol and potassium hydroxide.

Table 1. Intravenous, oral doses, and time points of assay of the different compounds.

Compound	IV dose ($\mu\text{mol/kg}$)	IV dose (mg/kg)	Oral dose ($\mu\text{mol/kg}$)	Oral dose (mg/kg)	Time points of assay
BDE-47	9.88	4.80	24.0	11.7	30 min, 24 h, 3 d, 7 d, and 28 d
BPS	10.5	2.63	18.2	4.56	15 min, 30 min, 1 h, 2 h, 4 h, 8 h, 12 h, 24 h, and 3 d
pp'DDE	2.26	0.72	14.4	4.57	30 min, 24 h, 3 d, 7 d, and 28 d
DEHP	NA	NA	28.3	11.1	15 min, 30 min, 1 h, 2 h, 4 h, 8 h, 12 h, 24 h, and 3 d
HCB	0.231	0.066	27.3	7.77	30 min, 24 h, 3 d, 7 d, and 28 d
β -HCH	1.52	0.44	6.97	2.03	30 min, 24 h, 3 d, 7 d, and 28 d
MEHP	4.18	1.16	NA	NA	15 min, 30 min, 1 h, 2 h, 4 h, 8 h, 12 h, 24 h, 3 d
PFOA	0.198	0.082	0.966	0.400	15 min, 30 min, 4 h, 12 h, 24 h, 3 d, 7 d, and 28 d
nPFOS	0.114	0.057	0.400	0.200	15 min, 30 min, 4 h, 12 h, 24 h, 3 d, 7 d, and 28 d
brPFOS	0.073	0.037	0.299	0.150	15 min, 30 min, 4 h, 12 h, 24 h, 3 d, 7 d, and 28 d

Note: The doses were back calculated from an assay of the dosing solutions. NA, not applicable; BDE-47, 2,2',4,4'-tetrabromodiphenyl ether; β -HCH, β -hexachlorocyclohexane; BPS, bisphenol S; brPFOS, branched isomer of perfluorooctane sulfonate; HCB, hexachlorobenzene; IV, intravenous; MEHP, mono(2-ethylhexyl)phthalate; PFOA, perfluorooctanoic acid; nPFOS, linear isomer of perfluorooctane sulfonate; pp'DDE, 1,1-Dichloro-2,2-bis(p-chlorophenyl)ethylene.

After 12 h of contact, samples were acidified and purified using two solid phase extraction steps (polystyrene divinyl benzene then carbon stationary phase). Final purified extracts were analyzed by LC-ESI(-)-MS/MS. At least two diagnostic signals (MRM transitions) were monitored per analyte.

For BPS and MEHP, 100 μ L of serum samples were spiked with internal standard ($^{13}\text{C}_{12}$ -BPS and $^4\text{C}_3$ -MEHP), then deconjugated using enzymatic hydrolysis (20 μ L mixture of water/acetate buffer 2 M/ β -glucuronidase 100/100/10 vol/vol/vol - β -glucuronidase from AbalonaTM, ASF beta-gluc-10 reference) for 2 h at 50°C. A liquid/liquid extraction was then performed with ethyl acetate, and organic phase was evaporated to dryness before derivatization with *N*-methyl-*N*-(trimethylsilyl)trifluoroacetamide (MSTFA). Extracts were analyzed by GC-MS/MS, monitoring two diagnostic signals (MRM transitions) per compound.

Total serum concentrations of BPS (i.e., unconjugated + conjugates) were quantified following incubation with a β -glucuronidase. Concentrations of unconjugated BPS were determined without the enzymatic hydrolysis step using the same methodology described above for total BPS. Considering that total serum concentrations of BPS represents mainly the sum of unconjugated and glucuronidated BPS (BPSG), we derived BPSG serum concentrations by subtracting unconjugated BPS from total BPS concentrations for TK analyses.

Drinking water and feed analysis. After drying feed in an oven at 80°C for 48h, BDE-47 and OCs were extracted with a toluene/acetone mixture (70:30, vol/vol) by Pressurized Liquid Extraction (SpeedExtractor-Büchi), and a liquid/liquid extraction using hexane was applied to the water sample. The ^{13}C -labeled internal standards were added to the samples before the extraction step. Purification steps were achieved on successive columns manually packed. The first step was a silica gel column loaded with sulfuric acid. The extract was further purified on Florisil[®] and carbon columns. Injection and quantification conditions were those described above for serum samples.

PFOA and PFOS were extracted and purified from 1 g of feed by solid/liquid extraction using a mixture of methanol and 0.01 M potassium hydroxide as described in a previous paper (Couderc et al. 2015). ^{13}C -labeled internal standards ($^{13}\text{C}_4$ -PFOA and $^{13}\text{C}_4$ -PFOS) were added to the sample before the extraction step. After 12 h of contact at room temperature, centrifugation at 700 $\times g$ for 5 min was performed, and the feed extract was acidified with formic acid (4 mL; 0.1 M) and then purified on two solid phase extraction cartridges polystyrene divinyl benzene (Waters) and carbon stationary phases (Supelco Sigma-Aldrich), and ^{13}C -labeled internal standards were directly added to 10 mL of water before the acidification and purification steps. Injection and quantification conditions were those described above for serum samples.

For BPS and MEHP, samples were analyzed as previously described (Deceuninck et al. 2014). Briefly, 1 g of feed sample was spiked with internal standard ($^{13}\text{C}_{12}$ -BPS and $^{13}\text{C}_4$ -MEHP) before performing solid/liquid extraction with a water/acetonitrile mixture. After 12 h of contact, the sample was purified using two solid phase extraction steps (polystyrene divinyl benzene, Macherey-Nagel) and MIP (Affinimip-BPA, Affinisep). The final purified extract was evaporated to dryness under a gentle stream of nitrogen before derivatization with MSTFA. A 5-mL sample of water was spiked with internal standards ($^{13}\text{C}_{12}$ -BPS and $^{13}\text{C}_4$ -MEHP), then deconjugated using enzymatic hydrolysis with 1 mL of acetate buffer 2 M and 10 μ L of β -glucuronidase. After 12 h of contact, the sample was purified using a solid phase extraction step (polystyrene divinyl benzene) as described in Deceuninck et al. (2014). The final purified extract was evaporated to dryness before derivatization with MSTFA. Injection and

quantification conditions were those described above for serum samples.

For all substances, the limits of detection (LOD) of the assays are given in Table S1.

Toxicokinetic Analyses

All TK analyses were performed using Phoenix WinNonlin[®] (version 8.3; Certara L.P.). Serum mass concentrations were converted into molar concentrations before analysis.

Noncompartmental analysis. Serum concentration-time profiles of the different compounds were first analyzed using a non-compartmental approach (NCA) involving a sparse data option. Sparse data methodology consists of calculating TK parameters based on the mean profile of all the subjects in the dataset and is appropriate when a rich data series cannot be obtained, as in the present experiment (FDA 1999). The area under the concentration time curve ($\text{AUC}_{0-t_{\text{last}}}$) and the area under the first moment curve ($\text{AUMC}_{0-t_{\text{last}}}$) from dosing time ($t = 0$) to the time of the last measurable concentration were calculated using the linear trapezoidal rule after IV and oral dosing. The area under the serum concentration time curve from dosing time to infinity ($\text{AUC}_{0-\text{inf}}$) was obtained by adding to $\text{AUC}_{0-t_{\text{last}}}$ the area extrapolated from the time of the last measurable concentration to infinity by dividing the last quantifiable serum concentration by the slope of the terminal phase (λ_z), as estimated by linear regression using the best fit option of Phoenix[®].

The clearance (CL) and apparent clearance (CL_F) were respectively estimated after IV and oral administrations by dividing the administered dose by the $\text{AUC}_{0-\text{inf}}$ calculated for each analyte.

The terminal half-life (HL) was estimated with Equation 1:

$$HL = 0.69315 / \lambda_z \quad (1)$$

where λ_z is the slope of the terminal phase.

The oral bioavailability (F) was estimated using Equation 2:

$$F = \frac{\text{AUC}_{\text{vo}0-t_{\text{last}}} \times \text{Dose}_{\text{iv}}}{\text{AUC}_{\text{iv}0-t_{\text{last}}} \times \text{Dose}_{\text{vo}}}, \quad (2)$$

where $\text{AUC}_{\text{iv}0-t_{\text{last}}}$ and $\text{AUC}_{\text{vo}0-t_{\text{last}}}$ are the values of $\text{AUC}_{0-t_{\text{last}}}$ obtained after IV and oral dosing, respectively, and Dose_{iv} and Dose_{vo} are the IV and oral doses.

The mean residence time (MRT) was estimated using Equation 3:

$$\text{MRT} = \frac{\text{AUMC}_{\text{iv}0-t_{\text{last}}}}{\text{AUC}_{\text{iv}0-t_{\text{last}}}}, \quad (3)$$

where $\text{AUMC}_{\text{iv}0-t_{\text{last}}}$ and $\text{AUC}_{\text{iv}0-t_{\text{last}}}$ are the values of $\text{AUMC}_{0-t_{\text{last}}}$ and $\text{AUC}_{0-t_{\text{last}}}$ obtained after IV dosing.

The steady-state volume of distribution (V_{SS}) was estimated using Equation 4:

$$V_{\text{SS}} = \text{CL} \times \text{MRT}, \quad (4)$$

with CL and MRT as defined above.

TK modeling. A nonlinear mixed effect (NLME) modeling approach was used to analyze simultaneously all data obtained from the different rabbits after both IV and oral administrations and to provide robust estimates of the typical TK parameters.

For all compounds except PFOA, the two-compartment model depicted in Figure 1 was selected based on the likelihood ratio test (LRT), the Akaike Information Criterion (AIC), and inspection of different diagnostic plots to better fit simultaneously the merged serum concentrations obtained after both IV and oral administrations. For PFOA, a three-compartmental model offered a better fit and was preferred.

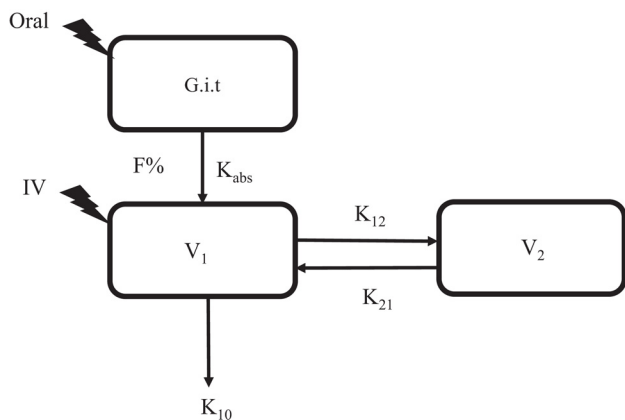

Figure 1. Schematic representation of the compartmental model. The model includes both a central and a peripheral compartment whose respective volumes are V_1 and V_2 . For the oral route, the compounds are administered in the absorption compartment (designated GIT) and linked to the central compartment with a rate constant of transfer (K_{abs}). The exchanges between the central and the peripheral compartments are bilateral, with K_{12} being the rate constant between the central and the peripheral compartments and K_{21} the rate constant between the peripheral and the central and compartments. Elimination of the compounds was modeled with a first-order rate constant designated K_{10} . The fraction of the compounds that reaches the central compartment unchanged, i.e., the bioavailability, is designated by $F\%$. Note: G.i.t, Gastrointestinal tract.

The primary parameters of the model, namely the volume of distribution of the central compartment (V_1), the first-order rate constants (K_{10} , K_{12} , K_{21} , and K_{abs} plus K_{13} , K_{31} for PFOA) and the bioavailability (F) and their associated precisions [standard error (SE)] were estimated by minimizing an objective function value (OFV) expressed as minus twice the log of the likelihood estimation ($-2LL$). Oral bioavailability was estimated by applying an ILogit transformation to preclude a value greater than 1. Marginal likelihood was approximated by using the Laplacian engine by default and, when this engine was unable to determine the SE of the estimate, the Quasi-Random Parametric Expectation Maximization (QRPEM) was selected.

Between subject variability (BSV) of the parameters was measured using the exponential model

$$\theta_{parameter_i} = \theta_{iv_parameter} \times \exp(\eta_i),$$

where $\theta_{parameter_i}$ is the parameter estimated for the i th individual, $\theta_{iv_parameter}$ is the typical population value of the parameter, and η_i is the deviation associated with the i th individual from the corresponding value of the parameter at the population level.

The distribution of η_i was assumed to be normal with a mean of 0 and a variance ω^2 . BSV was reported as a coefficient of variation (CV) in the original scale $CV(\%) = 100 \times \sqrt{\exp(\omega^2) - 1}$. Due to the very limited number of data, this random component could only be estimated for K_{abs} and F for which the shrinkage for η calculated as $shrinkage = 1 - \frac{SD(EBE_n)}{\omega}$ was lower than 30%, SD (EBE) being the standard deviation (SD) of the individual values of the Empirical Bayesian estimates (EBE) of η .

The residual variance was modeled using a combined additive and proportional error model $Cobs_{ij} = Cpred_{ij}(1 + \varepsilon_{1ij}) + \varepsilon_{2ij}$, where $Cobs_{ij}$ and $Cpred_{ij}$ are respectively the j th observed and predicted concentrations for the i th individual, and ε_{1ij} and ε_{2ij} are the multiplicative and additive residual errors.

The predictive ability of the model was checked graphically by plotting visual predictive check plots to compare the observed data with the 50th percentile of data simulated using the model and obtained from 500 replicates based on the

structure of the original data (i.e., dosing, timing, and number of samples). Due to the limited number of data, other quantiles were ignored.

Secondary parameters were calculated from the population primary parameters.

The clearance values (CL) were estimated using Equation 5:

$$CL = K_{10} \times V_1, \quad (5)$$

where V_1 is the volume of the central compartment and K_{10} is the elimination rate constant from the central compartment.

The volume of the peripheral compartment (V_2) was estimated with Equation 6:

$$V_2 = V_1 \times (K_{12}/K_{21}), \quad (6)$$

where K_{12} and K_{21} are the distribution rate constants between the central and the peripheral compartments.

The clearance of distribution (Q) was estimated using Equation 7:

$$Q = K_{12} \times V_1, \quad (7)$$

with V_2 and K_{12} as defined above.

V_{SS} and MRT were estimated with Equations 8 and 9:

$$V_{SS} = V_1 + V_2, \quad (8)$$

and

$$MRT = V_{SS}/CL, \quad (9)$$

with V_1 , V_2 , V_{SS} , and CL as defined above.

The volume of distribution associated with the terminal phase was estimated with Equation 10:

$$V_Z = CL/\lambda_Z, \quad (10)$$

with λ_Z as defined above.

The AUC was computed as a secondary parameter using Equation 11:

$$AUC = Dose/CL. \quad (11)$$

The terminal half-life was estimated with Equation 1, as previously described.

Estimation of the doses and model simulations. The ultimate goal of this TK investigation was to compute a dosage regimen that allowed targeted steady-state serum concentrations to be attained rapidly for a planned TK/TD trial on the reprotoxic effect of a mixture of environmental contaminants in female rabbits. Because some compounds were expected to have very long half-lives, a loading dose might be required to rapidly attain steady-state conditions. With that in mind, the loading and the daily maintenance doses of each compound were evaluated using Equations 12 and 13, respectively.

$$Loading\ dose = \frac{V_{ss} \times C_{ss}}{F} \quad (12)$$

and

$$Daily\ maintenance\ dose = \frac{Daily\ CL \times C_{ss}}{F}, \quad (13)$$

where C_{SS} is the steady-state serum concentration set at an arbitrary value of 1 ng/mL, and CL , V_{SS} , and F as defined above are the parameters estimated by the NLME model.

For each substance, the NLME model was used to simulate the serum concentration–time profiles resulting from oral administration of a dose corresponding to the sum of the loading and daily maintenance doses followed by that of the daily maintenance dose for 4 to 200 d. Although the serum concentrations apparently attained equilibrium, a possible delayed accumulation of compounds in a deep but small compartment cannot be ruled out. This point is often overlooked and had to be verified to eliminate the risk that such a deep compartment might include the ovarian system, which was precisely the subject of the TK/TD study. This risk was also the reason why the NLME model was employed to simulate the time development of the amounts of compounds in the central and peripheral compartments following administration of the daily maintenance dose of each compound over the same duration.

Because a random component is also considered in a NLME model, a Monte Carlo simulation that included a random component of 30% on the bioavailability was applied to assess its possible impact on the targeted steady-state serum concentrations (C_{SS}).

The loading and maintenance doses computed to ensure a nominal C_{SS} of 1 ng/mL were scaled to determine the doses to be administered by oral route to female rabbits to maintain the targeted C_{SS} .

Results

BDE-47 and HCB were detected in drinking water at 1.5 and 226 ng/mL, respectively, and at lower levels in the commercial

feed (0.01 and 0.1 ng/g weight of feed, respectively). The feed also contained DEHP at 8 ng/g weight of feed. The concentrations of the other compounds were below the LOD of the assays reported in Table S1. Despite the amounts of compounds detected in the drinking water and feed, the serum concentrations of all the targeted compounds in control rabbits, except for one BPS and one β -HCH serum concentration (30 ng/mL and 0.09 ng/mL), were lower than the LOD of the assay. This finding suggests that little to no external contamination had occurred during sample collection, processing, and assay.

Internal Exposure after IV and Oral Dosing

Figure 2 shows the time course of individual serum concentrations after IV and oral dosing. We identified a very large difference in persistence of the eight tested compounds, with the serum concentrations being undetectable 8–12 h after BPS and MEHP administration in several rabbits, whereas the concentrations of HCB and PFOS were still well above the LOD at the last sampling time (28 d) in all rabbits (Figure 2). Figure 2 also indicates the relatively “uniform” distribution of serum concentration and a likely biexponential decay for all compounds except PFOA, whose serum concentration–time profile followed a triexponential time course.

Tables 2 and 3 give the NCA estimates of TK parameters obtained after IV and oral dosing, respectively. The computed much longer half-lives of HCB and nPFOS after oral dosing suggested that NCA was unable to provide a correct estimate of this

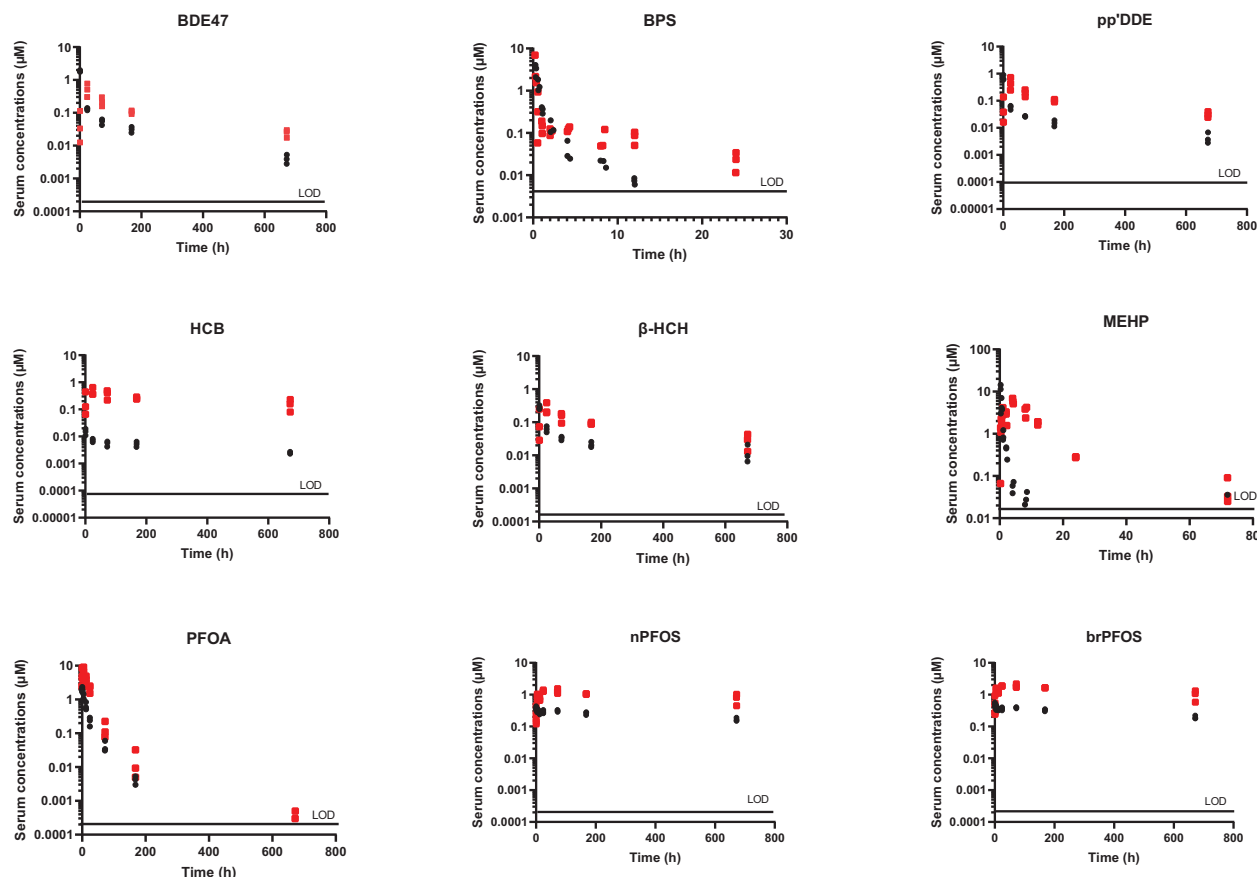

Figure 2. Semilogarithmic plots of individual serum concentrations ($\mu\text{mol/L}$) vs. time (h) of BDE-47, BPS, pp'DDE, HCB, β HCH, MEHP, PFOA, nPFOS, and brPFOS after intravenous (black circles) and oral dosing (red squares) in rabbits. The summary data can be found in tables S2 and S3. Note: BDE-47, 2,2',4,4'-tetrabromodiphenyl ether; β -HCH, β -hexachlorocyclohexane; BPS, bisphenol S; brPFOS, branched isomer of perfluorooctane sulfonate; HCB, hexachlorobenzene; LOD, limit of detection of the assays; MEHP, mono(2-ethylhexyl)phthalate; nPFOS, linear isomer of perfluorooctane sulfonate; PFOA, perfluorooctanoic acid; pp'DDE, 1,1-Dichloro-2,2-bis(p-chlorophenyl)ethylene.

Table 2. Toxicokinetic parameters estimated by noncompartmental analysis after IV dosing ($n = 12$).

	BDE-47	BPS	BPSG	pp'DDE	HCB	β -HCH	MEHP	PFOA	nPFOS	brPFOS
Dose ($\mu\text{mol}/\text{kg}$)	9.88	10.5	NA	2.26	0.231	1.52	4.18	0.198	0.114	0.073
Cmax (μM)	1.82	4.06	5.78	0.90	0.019	0.32	14.4	2.33	0.427	0.562
AUC _{0–inf} ($\mu\text{mol} \times \text{h}/\text{L}$)	42.2	2.41	5.18	19.8	4.52	26.7	9.73	27.4	330	359
CL ($\text{L}/\text{kg}/\text{h}$)	0.23	4.35	NA	0.11	0.051	0.057	0.429	0.00723	0.000346	0.000203
Half-life (h)	162	2.56	3.80	238	413	330	12.7	31.8	708	601
MRT (h)	86.9	1.26	3.16	203	551	543	16.3	18.7	971	813
V _{SS} (L/kg)	20.3	5.45	NA	23.2	28.1	30.9	7.00	0.135	0.336	0.165
V _Z (L/kg)	54.8	16.1	NA	39.2	30.5	27.1	7.85	0.332	0.353	0.176

Note: AUC_{0–inf}, area under the serum concentration-time curve from dosing time to infinity; NA, not applicable; BDE-47, 2,2',4,4'-tetrabromodiphenyl ether; β -HCH, β -hexachlorocyclohexane; BPS, bisphenol S; BPSG, bisphenol S glucuronide; brPFOS, branched isomer of perfluorooctane sulfonate; CL, clearance; Cmax, maximal serum concentration; HCB, hexachlorobenzene; IV, intravenous; MEHP, mono(2-ethylhexyl)phthalate; MRT, mean residence time; NA, nPFOS, linear isomer of perfluorooctane sulfonate; PFOA, perfluorooctanoic acid; pp'DDE, 1,1-Dichloro-2,2-bis(p-chlorophenyl)ethylene; Tmax, time of Cmax; V_{SS}, steady-state volume of distribution; V_Z, volume of distribution associated to the terminal phase.

parameter (see “Discussion” section). Similarly, the bioavailability estimations were greater or much greater than 100% for at least three compounds (PFOA, nPFOS, and brPFOS), which is theoretically impossible if a linearity of disposition is assumed (Toutain and Bousquet-Mélou 2004a). Because NCA was unable to generate robust estimates of TK parameters, a compartmental analysis using NLME modeling (or population modeling) was applied to analyze simultaneously all data collected after both IV and oral administrations.

TK Modeling

The population predicted vs. observed serum concentrations of BDE-47, BPS, pp'DDE, HCB, β -HCH, MEHP, PFOA, nPFOS, and brPFOS (Figures S1–S9) were evenly distributed around the line of identity of the diagnostic plots, suggesting that these data were appropriately described by the model. The goodness-of-fit plots for the corresponding individual predicted values suggested the absence of any major bias in the random component of the model.

Figures 3 and 4 show the results of the visual predictive check of the model after respective IV and oral dosing. For each compound, the observed 50% quantile was reasonably well overlaid by the 50% predictive check quantile, indicating that the model was able to capture the general trend of substance disposition. BSV could not be estimated for all the structural parameters due to the very few data available, and a random component was only added for K_{abs} and F . Nevertheless, these BSV estimates were rather poor and showed relatively high shrinkage.

The estimated primary parameters of the model (noted as vector thetas), namely V_c , F , K_{10} , K_{12} , K_{21} and K_{abs} are reported with their SE and their coefficients of variation (Tables S4–S12).

Table 4 shows the population secondary parameters of the eight substances. The oral bioavailability (F) was total for

nPFOS, brPFOS, and PFOA; very high (greater than 85%) for BDE-47 and β -HCH; intermediate for pp'DDE (72%) and BPS (63%); and $\sim 50\%$ for HCB. The F value for MEHP, estimated from the AUC values of MEHP obtained after MEHP IV and DEHP oral administrations (corresponding to the lowest estimated fraction of the DEHP dose that was metabolized into MEHP) was high (87%).

Persistence of the different compounds, as reflected by the MRT values, was highly variable, ranging from a few hours for BPS and MEHP to about 1,000 h for nPFOS and brPFOS, with intermediate values of 25 h for PFOA and one or a few hundred hours for BDE-47, pp'DDE, HCB, and β -HCH.

The low persistence of BPS resulted from very high clearance (3.2 L/kg/h) despite the relatively high distribution volume (20 L/kg). Similarly, MEHP persisted for only a few hours (8.2 h) because of its rather high clearance (0.47 L/kg/h) and its rather high distribution volume (about 4 L/kg). The long persistence of BDE-47, pp'DDE, HCB, and β -HCH (133–678 h), with lower clearance values ranging from about 0.05 to 0.34 L/kg/h, was mainly due to their very high volumes of distribution (33–45 L/kg). In contrast, the long persistence of the brominated and linear isomers of PFOS (about 1,000 h), with very small distribution volumes (0.19 and 0.37 L/kg), was related to their extremely low clearance (0.00019 and 0.00032 L/kg/h). The 40 times higher clearance of PFOA (0.0076 L/kg/h) in comparison with that of PFOS, despite being very low, explained its much lower persistence (25 h), even though the volume of distribution (0.19 L/kg) was similar.

The half-lives of the compounds, except for MEHP and PFOA, were of the same order as or lower than the respective MRT values. The terminal half-lives of MEHP (31 h) and PFOA (92 h) were greater than the corresponding MRT values (8.2 h and 25 h).

Table 3. Toxicokinetic parameters estimated by noncompartmental analysis after oral dosing ($n = 12$).

	BDE-47	BPS	BPSG	pp'DDE	HCB	β -HCH	MEHP*	PFOA	nPFOS	brPFOS
Dose ($\mu\text{mol}/\text{kg}$)	24.0	18.2	NA	14.4	27.3	6.97	28.3 (DEHP)	0.966	0.400	0.299
Cmax (μM)	0.64	6.93	6.91	0.58	0.505	0.297	6.87	9.07	1.3	1.94
Tmax (h)	24.0	0.23	0.27	24.0	24	24	4.05	4.05	24	72
AUC _{0–inf} ($\mu\text{mol} \times \text{h}/\text{L}$)	79.5	3.38	15.8	78.6	340	67.1	65.2	169	1,919	1,959
CL _F ($\text{L}/\text{kg}/\text{h}$)	0.30	5.39	1.15	0.18	0.080	0.104	NA	0.00572	0.000208	0.000153
Half-life (h)	267	5.65	4.23	260	816	314	10.4	77.6	1195	719
MRT (h)	258	6.54	7.66	307	1,115	369	12.0	25.9	1678	997
V _{Z,F} (L/kg)	116	44.0	7.03	68.8	95.0	47.0	6.53	0.64	0.359	0.158
F	0.78	0.81	NA	0.62	0.64	0.55	0.99	1.26	1.66	1.33

Note: *MEHP serum concentrations were measured following oral administration of DEHP, so the bioavailability (F) represents the fraction of the dose of DEHP that has been metabolized into MEHP. AUC_{0–inf}, area under the serum concentration-time curve from dosing time to infinity; NA, not applicable; BDE-47, 2,2',4,4'-tetrabromodiphenyl ether; β -HCH: β -hexachlorocyclohexane; BPS, bisphenol S; BPSG, bisphenol S glucuronide; brPFOS, branched isomer of perfluorooctane sulfonate; CL_F, apparent clearance; Cmax, maximal serum concentration; DEHP, di(2-ethylhexyl)phthalate; F, bioavailability; HCB, hexachlorobenzene; MEHP, mono(2-ethylhexyl)phthalate; MRT, mean residence time; PFOA, perfluorooctanoic acid; nPFOS, linear isomer of perfluorooctane sulfonate; pp'DDE, 1,1-Dichloro-2,2-bis(p-chlorophenyl)ethylene; Tmax, time of Cmax; V_{SS}, steady-state volume of distribution; V_{Z,F}, apparent volume of distribution associated to the terminal phase.

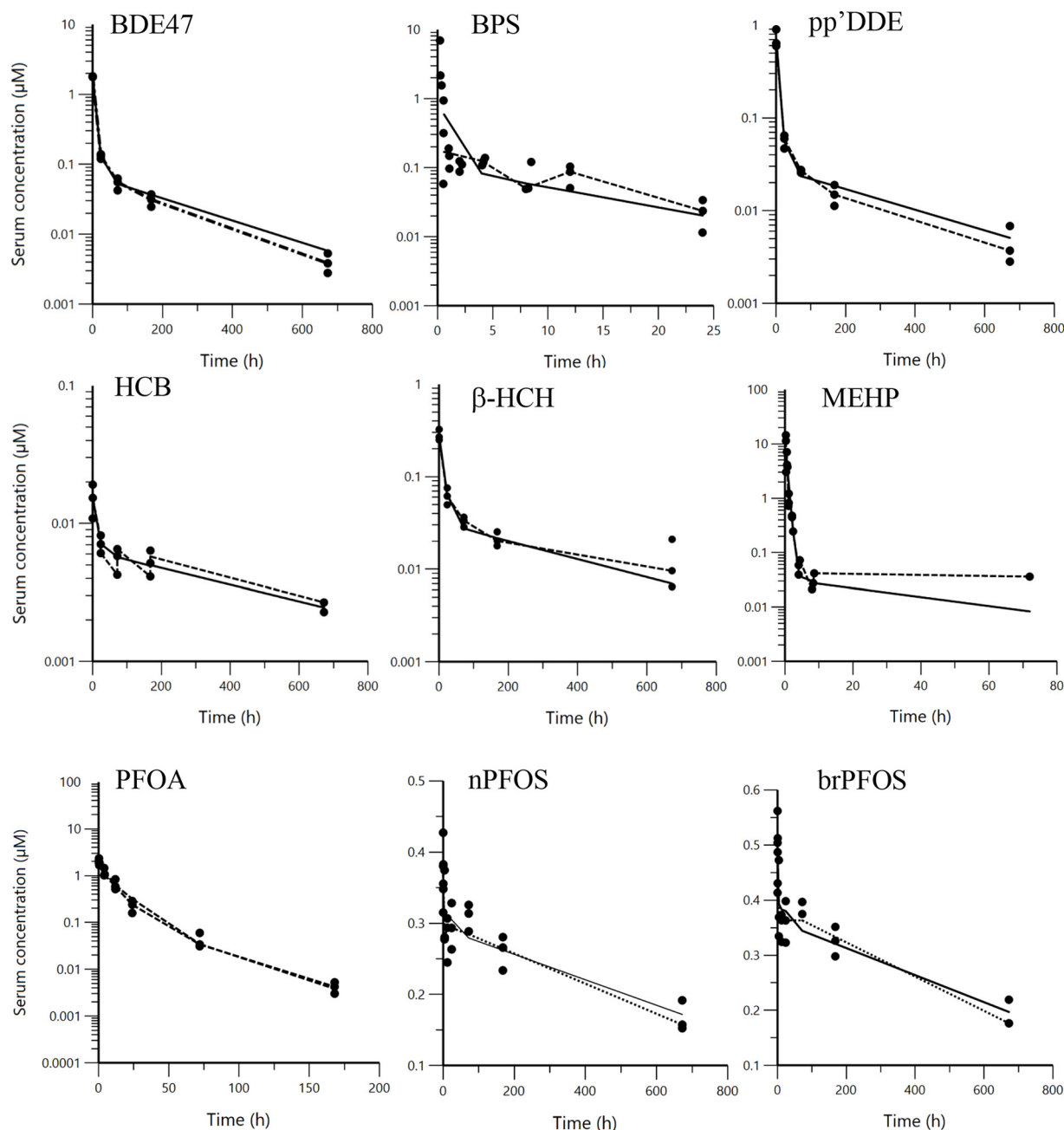

Figure 3. Visual predictive check (VPC) of serum concentrations of BDE-47, BPS, pp'DDE, HCB, β -HCH, MEHP, PFOA, nPFOS, and brPFOS after intravenous dosing as obtained with 500 replicates of each animal. Dashed lines: observed 50% quantile; solid lines: 50% quantile predicted by Monte Carlo simulation; black symbols: observed data. When the model ideally predicts the data, the observed and predicted quantiles are expected to be superimposed. The summary data can be found in Table S2. Note: BDE-47, 2,2',4,4'-tetrabromodiphenyl ether; β -HCH, β -hexachlorocyclohexane; BPS, bisphenol S; brPFOS, branched isomer of perfluorooctane sulfonate; HCB, hexachlorobenzene; MEHP, mono(2-ethylhexyl)phthalate; nPFOS, linear isomer of perfluorooctane sulfonate; PFOA, perfluorooctanoic acid; pp'DDE, 1,1-Dichloro-2,2-bis(p-chlorophenyl)ethylene.

Simulations and Dose Determination

Table 5 shows the loading and daily maintenance doses of the compounds required to rapidly attain and maintain serum concentrations at an arbitrary value of 1 ng/mL. Assuming the linearity of disposition, to extrapolate the rate of exposure, a factor corresponding to the targeted C_{SS} could be applied to the doses thus determined.

Figure 5 shows, for the eight compounds, the model-simulated serum concentration–time profiles resulting from the oral administration of a dose corresponding to the sum of the loading and daily maintenance doses followed by that of the daily maintenance dose for 4 to 200 d. Visual inspection of the figure

shows that the serum concentrations of BPS, MEHP, and PFOA are predicted to widely fluctuate around the targeted concentration of 1 ng/mL while almost no fluctuations around the targeted concentration were observed for the serum concentrations of BDE-47, DDE, HCB, β -HCH, nPFOS, and brPFOS. Despite fluctuations, the trough concentrations remained constant across time from the first administration of BPS and after approximately four administrations of MEHP and PFOA. The magnitude of fluctuations in serum BPS concentrations, as reflected by the ratio between the minimal and maximal concentrations of about 100, was much greater than those of MEHP and PFOA, whose concentration ratios were about 5.

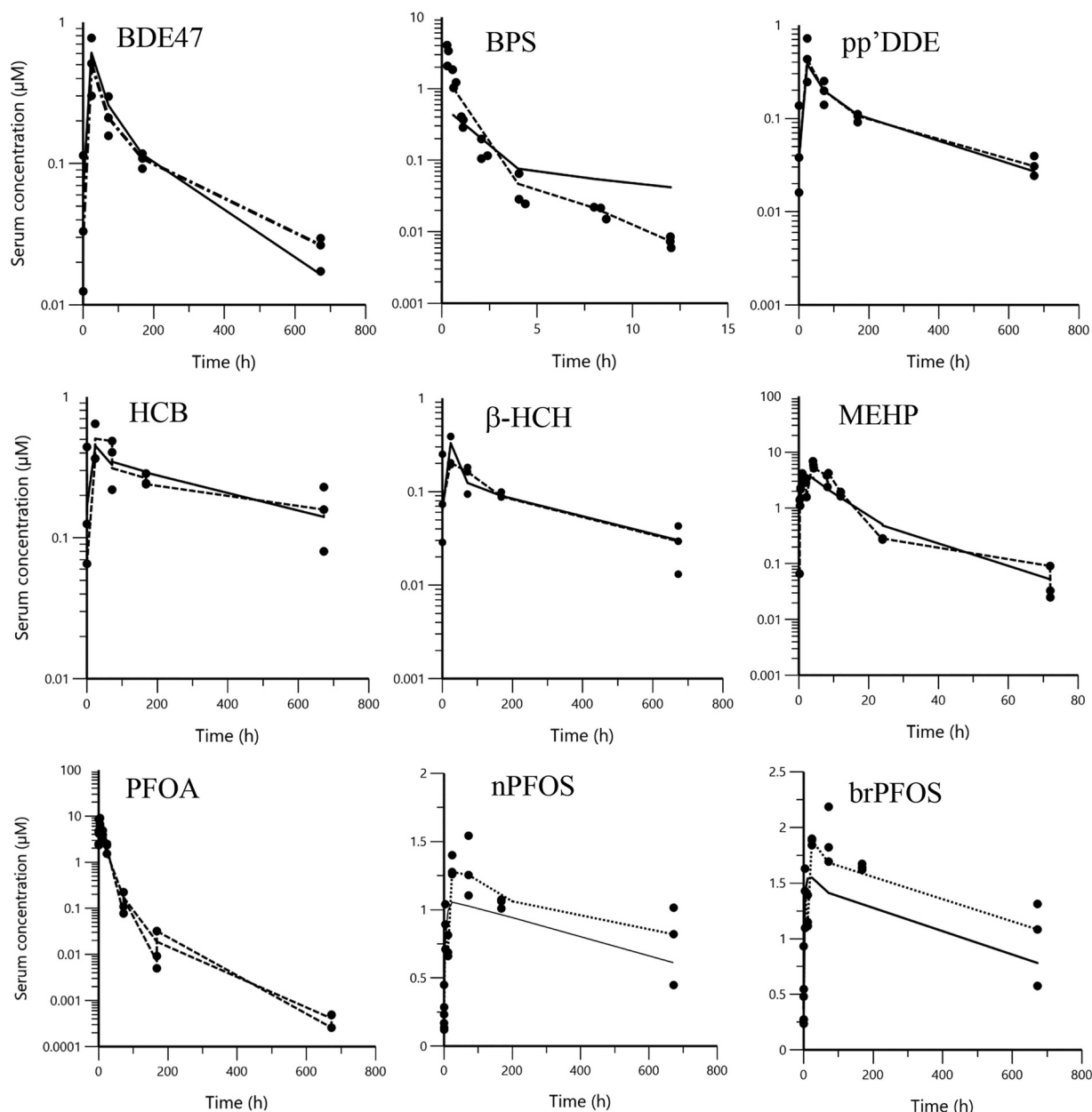

Figure 4. Visual predictive check (VPC) of serum concentrations of BDE-47, BPS, pp'DDE, HCB, β -HCH, MEHP, PFOA, nPFOS, and brPFOS after oral dosing as obtained with 500 replicates of each animal. Dashed lines: observed 50% quantile; solid lines: 50% quantile predicted by Monte Carlo Simulation; black symbols: observed data. When the model ideally predicts the data, the observed and predicted quantiles are expected to be superimposed. The summary data can be found in Table S3. Note: BDE-47, 2,2',4,4'-tetrabromodiphenyl ether; β -HCH, β -hexachlorocyclohexane; BPS, bisphenol S; brPFOS, branched isomer of perfluorooctane sulfonate; HCB, hexachlorobenzene; MEHP, mono(2-ethylhexyl)phthalate; nPFOS, linear isomer of perfluorooctane sulfonate; PFOA, perfluorooctanoic acid; pp'DDE, 1,1-Dichloro-2,2-bis(p-chlorophenyl)ethylene.

Compartmental modeling was able to simulate the time development of the amounts of each substance in the central and peripheral compartments following daily oral administration of the maintenance dose alone (Figure 6). Visual inspection of Figure 6 reveals a parallel accumulation of HCB in the deep and the central compartments. In contrast, progressive accumulation in the peripheral compartment continued for BDE-47, pp'DDE, β -HCH, MEHP, PFOA, nPFOS, and brPFOS, whereas the central compartment seemed to attain pseudoequilibrium more rapidly. Figure S10 illustrates this situation for MEHP when an analytical method associated with an estimated measurement uncertainty of 20% was used to measure daily serum concentrations. For PFOA, the situation was even more complicated because the plasma and superficial compartments rapidly

attained pseudoequilibrium, whereas accumulation continued to increase over time in the small and deepest compartment (Figure 6).

Table 6 gives for each compound the nominal loading and maintenance doses therefore computed to ensure the targeted C_{SS} . These targeted C_{SS} were selected to achieve 10-fold either the 90th or 95th percentile values from biomonitoring studies in pregnant women for all compounds except BPS, for which it was 10-fold the geometric mean. Doses that were actually administered were close to the predicted nominal doses (Table 6). Observed C_{SS} were evaluated in female rabbits treated from 2 to 19 weeks of age (Table 6). In control rabbits, BPS, MEHP, PFOA, and BDE-47 were not detected, whereas the mean serum concentrations of PFOS, β -HCH, HCB, and pp'DDE were 0.76 ± 0.80 , 0.073 ± 0.017 ,

Table 4. Population secondary parameters as obtained with a two- or three-compartment model.

	BDE-47		BPS		pp'DDE		HCB		β-HCH		MEHP*		PFOA**		nPFOS		brPFOS	
	Mean	CV (%)	Mean	CV (%)	Mean	CV (%)	Mean	CV (%)	Mean	CV (%)	Mean	CV (%)	Mean	CV (%)	Mean	CV (%)	Mean	CV (%)
Bioavailability	0.96	31	0.63	22	0.72	1.6	0.51	15	0.88	0.12	0.87	17	11	1	6.8	1	1	6.5
Clearance (L/kg/h)	0.34	26	3.2	23	0.13	3.9	0.051	40	0.087	1.4	0.47	15	0.0076	15	0.00032	10	0.00019	8.6
Clearance(s) of distribution (L/kg/h)	0.36	72	2.3	37	0.24	10	0.78	42	0.30	1.7	0.094	41	0.0047	189&28	0.044	199	0.027	127
Volume(s) of the peripheral compartment (L/kg)	39	43	18	51	32	8	20	27	28	1.7	3.5	98	&0.00039	84&28	0.077	33	0.049	22
AUC _{iv} (μmol × h/L)	29	26	3.3	23	17	4	4.5	40	20	1.4	9.0	15	26	15	355	10	385	8.6
AUC _{vo} (μmol × h/L)	71	26	3.6	18	77	5.5	271	35	87	1.5	53	12	128	15	1,246	12	1,575	11
AUC _{vo} /dose (μmol × h/L per μmol/kg BW)	2.97	—	0.20	—	5.35	—	9.92	—	12.5	—	NA	—	133	—	3,115	—	5,268	—
V _{ss} (L/kg)	45	45	20	49	35	7.5	35	11	33	1.6	3.8	90	0.19	21	0.37	4.3	0.19	4.7
Half-life (h)	163	7.5	9.9	39	271	6.9	480	48	318	0.25	31	69	92	10	793	12	685	11
MRT (h)	133	22	6.3	49	261	11	678	48	379	0.28	8.2	96	25	8.7	1,143	12	988	11

Note: The precision of the estimate was measured with the coefficient of variation, CV%. *MEHP serum concentrations were measured following oral administration of DEHP, so the bioavailability represents the fraction of the dose of DEHP that has been metabolized into MEHP. **Population secondary parameters of PFOA were obtained with a three-compartment model. —, no data; AUC_{iv}, area under the serum concentration-time curve from dosing time to infinity after intravenous dosing; AUC_{vo}, area under the serum concentration-time curve from dosing time to infinity after oral dosing; BDE-47, 2,2',4,4'-tetrabromodiphenyl ether; BPS, bisphenol S; brPFOS, branched isomer of perfluorooctane sulfonate; DEHP, Di(2-ethylhexyl)phthalate; HCB, hexachlorocyclohexane; MEHP, Mono(2-ethylhexyl)phthalate; MRT, mean residence time; PFOA, perfluorooctanoic acid; nPFOS, linear isomer of perfluorooctane sulfonate; pp'DDE, 1,1-Dichloro-2,2-bis(p-chlorophenyl)ethylene; V_{ss}, steady-state volume of distribution.

0.013 ± 0.013, and 0.067 ± 0.089 ng/mL, respectively, indicating some background exposure. The ratio between observed and targeted C_{SS} ranged from 0.77 to 1.21 for all compounds except BPS, for which only total BPS was measured. By considering the mean fraction of total BPS in plasma that was unconjugated in rabbits 4 h after oral administration in the TK study (7%), the mean serum concentration of BPS was estimated at 0.98 ng/mL for a targeted C_{SS} of 1 ng/mL.

Discussion

The purpose of this study was to experimentally determine, while respecting the rule of 4R, the dosage regimen (loading and maintenance doses) required for a series of eight environmental contaminants to ensure a nominal steady-state plasma concentration of 1 ng/mL. Our broader goal was to allow the determination of a dosage regimen for these eight substances so that any other plasma concentrations that might need to be targeted for some specific toxicological objectives could be obtained by simple scaling of these calculated doses. To achieve this objective and respect a minimal usage of laboratory animals, a mixture approach involving the simultaneous administration of all eight substances was adopted, and blood sampling was limited to three per animal. The concurrent assay of numerous substances in a single sample and adherence to these ethical constraints required the availability of efficient analytical techniques, in terms of level of quantification, and advanced data analyses able to handle sparse and unbalanced data, namely NLME modeling. Indeed, NLME is the only tool that is appropriate for analyzing sparse and unbalanced data [i.e., from a study design in which not all individuals supply the same amount of information (Li et al. 2015)].

Besides oral dosing, IV administrations were also required because major TK parameters such as plasma clearance and V_{SS} can only be estimated by IV route (Benet and Zia-Amirhosseini 1995). These two parameters can be used not only to calculate the respective maintenance and loading doses (Toutain and Bousquet-Mélou 2004d), but are most appropriate for interspecies and *in vitro/in vivo* extrapolations (i.e., the so-called IVIVC approach) and consideration in PBPK modeling. In addition, the data obtained by IV route provide internal reference exposures for other modalities of administration of these eight substances, making it possible to estimate the order of magnitude of bioavailability without such IV administrations needing to be repeated for each substance. More broadly, the information provided by the present experiment could be incorporated into an *a posteriori* Bayesian estimation approach, allowing individual exposures (e.g., AUC) to be calculated from just a few individual observations collected in new trials, for any TK/TD investigation.

The interest in the mixture approach has received extensive discussion, especially in the context of the pharmacokinetics of active substances used as drugs (Frick et al. 1998; Nguyen et al. 2016). Its main advantage is to satisfy several of the needs for high-throughput methods. In the present trial, the mixture approach also enabled eight times fewer rabbits to be used than a routine design based on classical discrete dosing studies. Limits of the mixture approach regarding possible disposition interactions between the test articles and the need to satisfy the linearity hypothesis to permit extrapolation to higher therapeutic doses have been well identified (White and Manitpisitkul 2001). These two issues present differently in the context of environmental toxicology for two reasons. First, the mixture approach is not necessarily a limit with regard to environmental exposure to a mixture of contaminants, now the subject of recent methodological developments (Pletz et al. 2020). Indeed, our eight hazardous substances assessed simultaneously in

Table 5. Estimated loading and daily maintenance doses of the compounds required to rapidly attain and maintain serum concentration levels set at an arbitrary value of 1 ng/mL.

	BDE-47	BPS	pp'DDE	HCB	β -HCH	DEHP	PFOA	nPFOS	brPFOS
Loading dose ($\mu\text{g}/\text{kg}$)	47	32	49	68	37	4.4	0.19	0.37	0.19
Daily maintenance dose ($\mu\text{g}/\text{kg}$)	8.4	122	4.5	2.4	2.4	13	0.18	0.0077	0.0046

Note: BDE-47, 2,2',4,4'-tetrabromodiphenyl ether; BPS, bisphenol S; brPFOS, branched isomer of perfluorooctane sulfonate; DEHP, Di(2-ethylhexyl)phthalate; HCB, hexachlorobenzene; β -HCH, β -hexachlorocyclohexane; MEHP, Mono(2-ethylhexyl)phthalate; nPFOS, linear isomer of perfluorooctane sulfonate; PFOA, perfluorooctanoic acid; pp'DDE, 1,1-Dichloro-2,2-bis(p-chlorophenyl)ethylene.

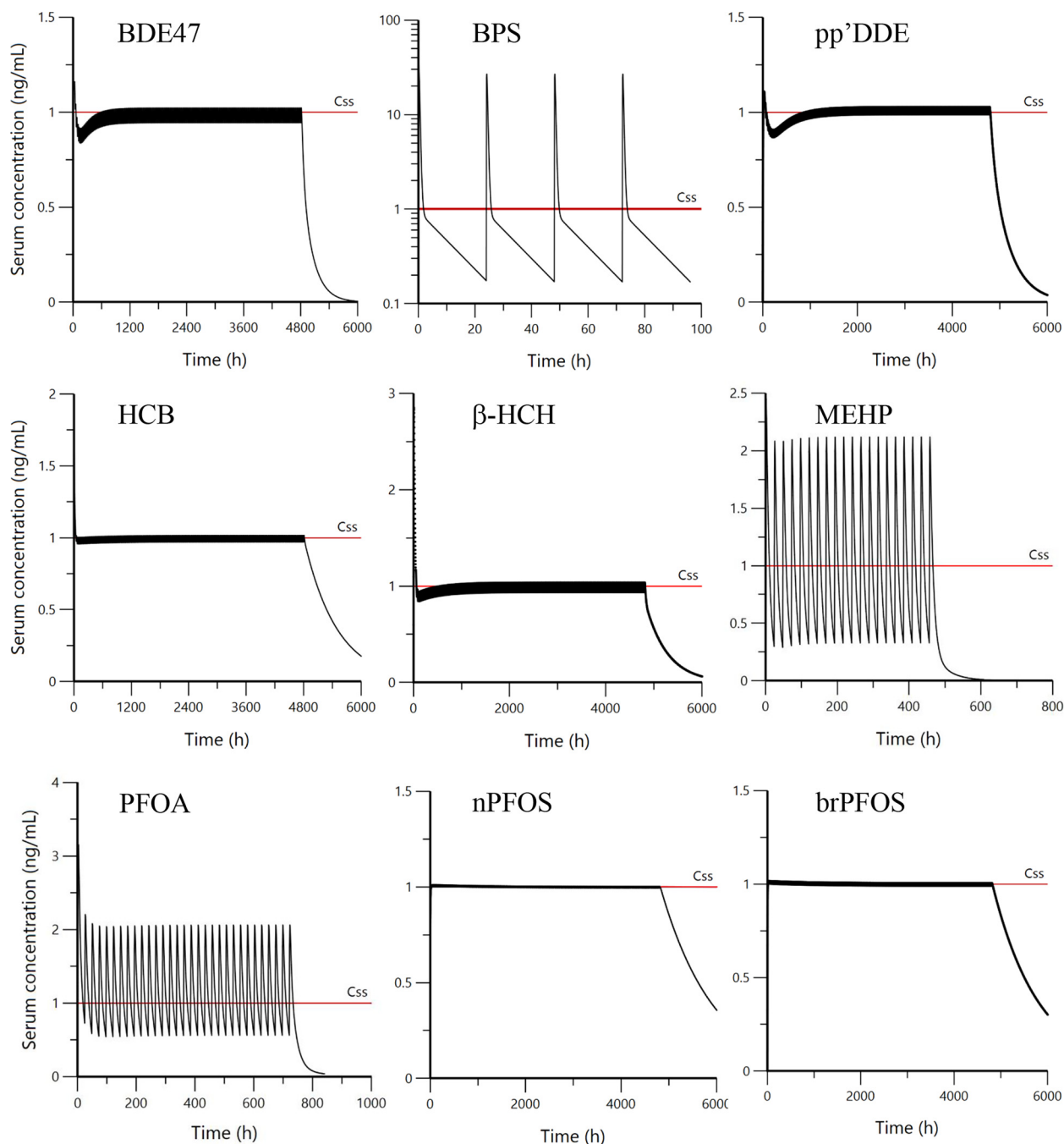

Figure 5. Time development of serum concentrations (ng/mL) of BDE-47, BPS, pp'DDE, MEHP, HCB, β -HCH, PFOA, nPFOS, and brPFOS after an initial oral administration of a dose corresponding to the sum of the loading and daily maintenance doses followed by daily administrations of the maintenance dose for 4 to 200 d. The red horizontal line represents the targeted steady state concentration of 1 ng/mL (C_{SS}). The loading vs. daily maintenance doses were 47 vs. 8.4 $\mu\text{g}/\text{kg}$ for BDE-47, 32 vs. 122 $\mu\text{g}/\text{kg}$ for BPS, 49 vs. 4.5 $\mu\text{g}/\text{kg}$ for pp'DDE, 68 vs. 2.4 $\mu\text{g}/\text{kg}$ for HCB, 37 vs. 2.4 $\mu\text{g}/\text{kg}$ for β -HCH, 4.4 vs. 13 $\mu\text{g}/\text{kg}$ for DEHP, 0.19 vs. 0.18 $\mu\text{g}/\text{kg}$ for PFOA, 0.37 vs. 0.0077 $\mu\text{g}/\text{kg}$ for nPFOS, and 0.19 vs. 0.0046 $\mu\text{g}/\text{kg}$ for brPFOS. Note: BDE-47, 2,2',4,4'-tetrabromodiphenyl ether; β -HCH, β -hexachlorocyclohexane; BPS, bisphenol S; brPFOS, branched isomer of perfluorooctane sulfonate; HCB, hexachlorobenzene; MEHP, mono(2-ethylhexyl)phthalate; nPFOS, linear isomer of perfluorooctane sulfonate; PFOA, perfluorooctanoic acid; pp'DDE, 1,1-Dichloro-2,2-bis(p-chlorophenyl)ethylene.

rabbits were selected because they represent major classes of compounds ubiquitous in the environment and human samples. Second, the oral doses used to determine the kinetic parameters were much higher (from 37 to 32,609-fold) than the daily doses extrapolated for our future toxicodynamic investigations, and besides this, the concentrations actually achieved in the rabbits used for the chronic study were indeed in conformity with the expected concentrations. This result eliminates the risk for future trials that would be carried out with higher doses than the toxicodynamic dose of a nonlinearity of disposition due to the saturation of the clearing mechanisms. In the present trial, the closeness of our brPFOS clearance estimate, for a dosage of 200 $\mu\text{g}/\text{kg}$ (0.19 mL/kg/h), to the apparent clearance previously determined from oral kinetic data observed in rabbits under low repeated oral dosing (0.085 $\mu\text{g}/\text{kg}/\text{d}$), i.e., 0.08 mL/kg/h (Tarazona et al. 2016), supported the reliability of our approach. The comparability of our estimate of HCB half-life (480 h) with that previously evaluated in rabbits from data derived from a single dose administration (768 h, Scheufler and Rozman 1984) was also worth mentioning. Finally, the success of our TK model-based predictions may give confidence to our estimates of the TK parameters for all the tested chemicals. Indeed, the preliminary results of the chronic study based on dosage regimen computed from these estimates have shown that the mean concentrations of the eight substances ranged from 0.77 to 1.21 of the targeted C_{SS} , which fully met the assigned objectives. It also supported the lack of dose-dependent kinetics for the eight compounds and significant drug–drug interactions in the large range of doses used.

Our data analysis was based on using NLME modeling that has already been promoted for TK by other authors (Aarons and Graham 2001; Fourcot et al. 2020) but rarely applied because of its relative complexity. Its main advantages are that it is able to handle sparse and unbalanced data and thereby preclude the risk of obtaining unrealistic estimates of certain parameters, as can happen with NCA when the data are not rich enough, are poorly distributed, and are thus unable to capture the shape of the disposition curve (Nguyen et al. 2016) or are censored for experimental or analytical reasons (Hing et al. 2001a). For example, the oral bioavailabilities of PFOA and nPFOS estimated by NCA were 126% and 166%, respectively, which was biologically impossible but not unlikely if the NCA estimates of bioavailability were derived from different groups of animals for the IV and non-IV routes of administration. More generically, NLME modeling provides more reliable and less biased parameters than routine analyses of naïve pooled data for TK as documented using simulations (Hing et al. 2001b). Another advantage of NLME modeling is that it allows for the use of the population model to obtain subsequent empirical Bayesian estimates of individual TK parameters of new animals exposed to the substance for which data is very sparse or sampling destructive (Nguyen et al. 2016). In this way, a complete individual concentration profile can be estimated for each animal according to its dosing history, allowing, for example, the individual TK/TD relationship for such animals to be determined (see Steimer et al. 1993). Regarding the present project, this approach will now be adopted to investigate the female reprotoxic effect of the final mixture of eight substances, and NLME forecasting should preclude the need for a satellite group of rabbits (Nedelman et al. 1993) and thus save their use for a pivotal trial. Although the sex differences in the half-life of PFOA that exist in rats were not reported in other species, including rabbits (Hundley et al. 2006; Kudo and Kawashima 2003), we cannot rule out possible sex differences in the TK parameters of the other compounds, which should be taken into account for dose selection in future studies aiming to test male-mediated reproductive toxicity in rabbits.

Our investigation, based on the use of simple two- or three-compartmental models, also highlighted the need for caution when interpreting an apparent steady-state serum concentration in the presence of experimental noise with regard to the actual time development of the amount of substance in a peripheral deep compartment. This caution must be considered for BDE-47, pp'DDE, β -HCH, MEHP, PFOA, nPFOS, and brPFOS. Depending on the value of the clearance of distribution and the apparent volume of the deep compartment, it appeared that serum concentrations could rapidly attain a more or less steady concentration even though the substance continued to accumulate in the deep compartment (see Figure 6 for MEHP). This point deserves attention regarding the organ or tissue to be targeted in future toxicological investigations. Indeed, the serum concentrations measured under experimental conditions were inevitably marred by an analytical error, and serum concentrations of the same order of magnitude could be measured at the start of exposure or after long-term exposure to the substance in question. Actually, a given measured serum concentration could correspond to two totally different situations in terms of tissue concentrations at the level of a target structure belonging to the deep compartment. In contrast to a PB/PK model, the exact location of the deep compartment remains unknown, but the time required to reach a true state of equilibrium can be correctly anticipated for the whole organism when a maintenance dose is to be administered, and a loading dose can be used if that time might be considered too long.

Based on the IV data and assuming the linearity of substances disposition, the estimated oral bioavailability was greater than 72% for all compounds except BPS (63%) and HCB (51%), indicating that the high range of oral systemic exposures (from 0.20 for BPS to 5,268 $\mu\text{mol}/\text{h}/\text{L}$ per $\mu\text{mol}/\text{kg}$ BW for brPFOS) could be mainly explained by differences in substance clearance (from 0.19 mL/kg/h for the branched isomer of PFOS to 3,200 mL/kg/h for BPS). The very high bioavailabilities of BDE-47 (96%), pp'DDE (72%), β -HCH (88%), PFOA, and PFOS (100%) were in agreement with their efficient intestinal absorptions, as previously demonstrated in rodents for BDE-47 (82%, Staskal et al. 2005), β HCH (80%–95%; WHO 1992), PFOA (93%, (Kudo and Kawashima 2003), and PFOS (117%, Chang et al. 2012). Sieber (1976) showed that gastrointestinal absorption by the intestinal lymphatic system contributed to the efficient uptake of pp'DDE. The high rate of conversion of DEHP into MEHP (87%) suggested that MEHP, derived mostly from presystemic DEHP metabolism, was also efficiently absorbed. Collectively these results supported the utility of using rabbits as an experimental species for TK studies and the validity of our oral mixture approach for the next phase of our project.

In human investigations, the parameter most often reported is the (terminal) HL, because it can be computed without any knowledge of the level of external exposure and also because the time units (hour, day) make it a more attractive parameter to deal with than clearance for which the unit is a flow (e.g., liter per kilogram per hour, Toutain and Bousquet-Mélou 2004c). The high values obtained here for HL (>150 h), except for PFOA (92 h), MEHP (31 h), and BPS (9.9 h), indicated their considerable persistence and the need for a loading dose to rapidly attain the target plasma concentrations. MRT provided an even more attractive and more accurate metric of persistence. The MRT encompasses all phases of substance disposition, whereas the HL only reflects the rate of elimination during the terminal phase (Toutain and Bousquet-Mélou 2004c). For example, the MRT was 47.6 d for nPFOS, i.e., higher than its terminal HL of 33 d. Conversely, the terminal HL of PFOA (92 h) was much longer than its MRT (25 h), indicating a slower rate of elimination from the deep compartment but a relatively small contribution of this compartment to the overall

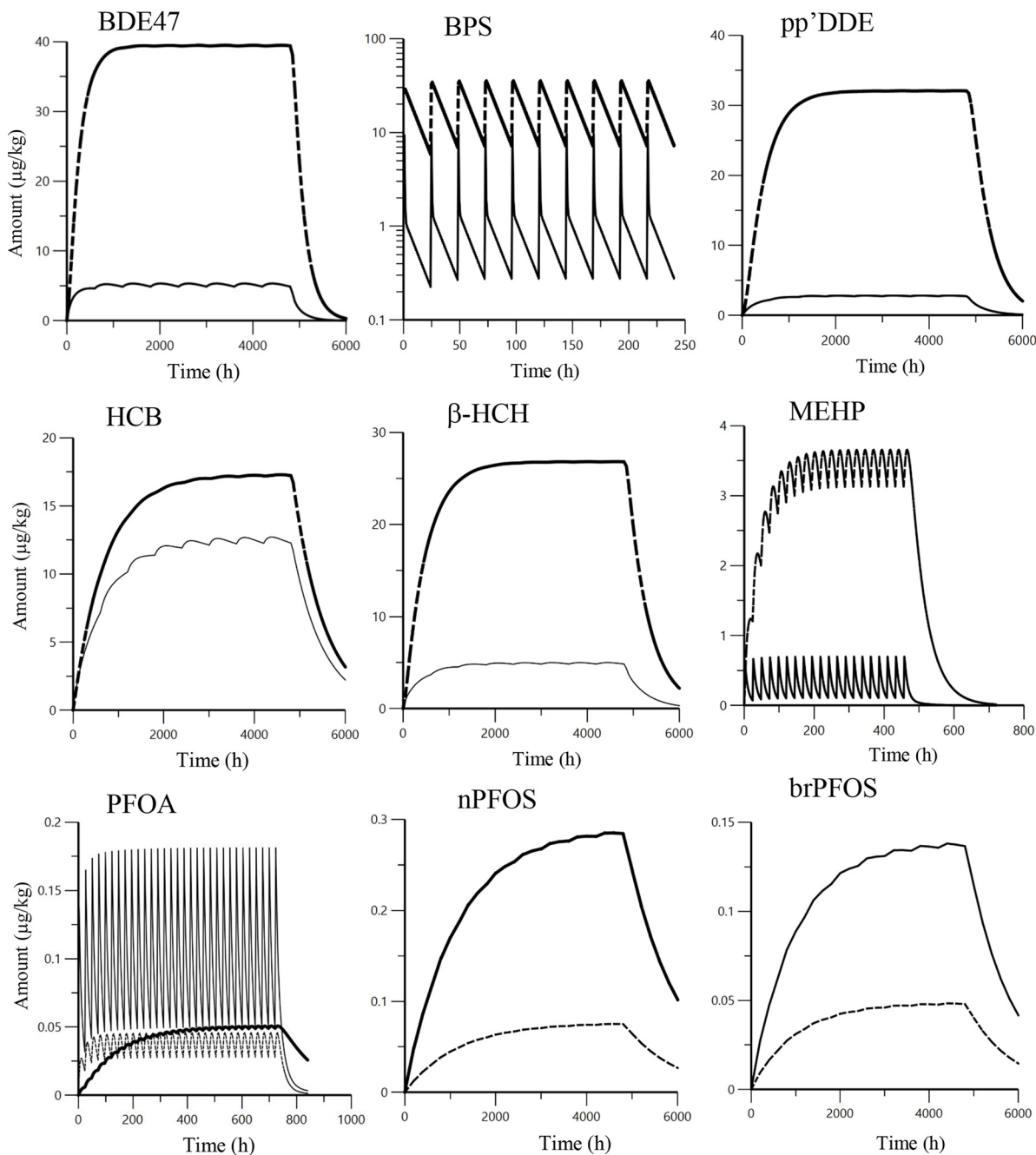

Figure 6. Time development of the amount of BDE-47, BPS, pp'DDE, MEHP, HCB, β -HCH, PFOA, nPFOS, and brPFOS in the central compartment (solid line) and peripheral compartment (dashed line) for repeated daily oral administrations of the maintenance doses, intended to achieve a serum steady state concentration of 1 ng/mL. The amounts of PFOA in the superficial (dashed line) and the deep (thick solid line) peripheral compartments are represented. The loading vs. daily maintenance doses were 47 vs. 8.4 $\mu\text{g}/\text{kg}$ for BDE-47, 32 vs. 122 $\mu\text{g}/\text{kg}$ for BPS, 49 vs. 4.5 $\mu\text{g}/\text{kg}$ for pp'DDE, 68 vs. 2.4 $\mu\text{g}/\text{kg}$ for HCB, 37 vs. 2.4 $\mu\text{g}/\text{kg}$ for β -HCH, 4.4 vs. 13 $\mu\text{g}/\text{kg}$ for DEHP, 0.19 vs. 0.18 $\mu\text{g}/\text{kg}$ for PFOA, 0.37 vs. 0.0077 $\mu\text{g}/\text{kg}$ for nPFOS, and 0.19 vs. 0.0046 $\mu\text{g}/\text{kg}$ for brPFOS. Note: BDE-47, 2,2',4,4'-tetrabromodiphenyl ether; β -HCH, β -hexachlorocyclohexane; BPS, bisphenol S; brPFOS, branched isomer of perfluorooctane sulfonate; HCB, hexachlorobenzene; MEHP, mono(2-ethylhexyl)phthalate; nPFOS, linear isomer of perfluorooctane sulfonate; PFOA, perfluorooctanoic acid; pp'DDE, 1,1-Dichloro-2,2-bis(p-chlorophenyl)ethylene.

substance disposition. The same situation held for MEHP, with HL and MRT values of 31 h and 8.2 h, respectively (see Sobol and Bialer 2004 for an explanation of the origin of the differences between MRT and HL for a two-compartment body model).

MRT and HL are hybrid parameters reflecting both the plasma clearance and a volume term (V_{SS} for MRT and V_z for HL), and a same long MRT or HL can be obtained by using different combinations of these two primary parameters (Toutain and Bousquet-Mélou 2004c, 2004b, 2004d). This was the case

for nPFOS or brPFOS vs. HCB. Although the MRT of all three substances exceeded 800 h, for nPFOS and brPFOS this long MRT was due to a very low plasma clearance, and for HCB, it resulted mainly from a very large volume of distribution. Similarly, the overall elimination of BDE-47, pp'DDE, and β -HCH was not limited by the body's extraction capacities, which for these persistent organic pollutants were not negligible (0.051–0.34 L/kg/h), but rather by their high V_{SS} , which ranged from 33 to 45 L/kg. These high V_{SS} values indicated that a large

Table 6. Observed steady-state serum concentration (C_{SS} , mean \pm SD) of rabbit females ($n = 16$) after 17 weeks of treatment with a mixture of the eight compounds orally administered.

Compound	Targeted C_{SS} * (ng/mL)	References	Computed loading dose (μ g/kg)	Computed maintenance dose (μ g/kg)	Administered loading dose (μ g/kg)	Administered maintenance dose (μ g/kg)	Observed C_{SS} (ng/mL)
BDE-47	0.16	Tamayo-Uria et al. 2019	7.5	1.3	8.9	1.1	0.16 \pm 0.058
BPS	1.00	Gerona et al. 2018	32	122	32.0	122	15 ^{**} \pm 5.8
pp'DDE	21	Tamayo-Uria et al. 2019	1,039	95	1,051	96	25 \pm 12
HCB	2.4	Tamayo-Uria et al. 2019	163	5.8	180	5.6	2.9 \pm 1.5
β -HCH	4.4	Vrijheid et al. 2012	163	11	165	10	4.3 \pm 1.6
DEHP	60	Assens et al. 2019	264	780	262	770	51 \pm 28 (MEHP)
PFOA	53	Tamayo-Uria et al. 2019	10	9.5	9.9	9.8	43 \pm 9.4
PFOS (39% brPFOS/ 61% nPFOS)	200	Tamayo-Uria et al. 2019	60	1.3	56.7	1.0	154 \pm 25

Note: The actually administered loading and daily maintenance doses were close to those computed to ensure targeted C_{SS} based on biomonitoring studies in pregnant women. *Targeted steady-state serum concentrations (C_{SS}) represented tenfold either the 90th or 95th percentile values from biomonitoring studies in pregnant women for all compounds except BPS, for which it was tenfold the geometric mean. **As total BPS, corresponding to about 1 ng/mL of unconjugated BPS (see "Discussion" section for explanation). BDE-47, 2,2',4,4'-tetrabromodiphenyl ether; BPS, bisphenol S; DEHP, di(2-ethylhexyl)phthalate; brPFOS, branched isomer of perfluorooctane sulfonate; HCB, hexachlorobenzene; β -HCH, β -hexachlorocyclohexane; MEHP, mono(2-ethylhexyl)phthalate; PFOA, perfluorooctanoic acid, nPFOS, linear isomer of perfluorooctane sulfonate; pp'DDE, 1,1-Dichloro-2,2-bis(p-chlorophenyl)ethylene.

fraction of these substances remained outside the central compartment, in agreement with the reported high concentration ratio in adipose tissue (lipid weight) and plasma (total weight) of the highly lipophilic compounds, pp'DDE (230:1), HCB (246:1), and β HCH (292:1, Needham et al. 1990). The potential of BDE-47 to accumulate in lipid-rich tissues was also evidenced in early studies of its distribution in humans (She et al. 2002) and animals (Orn and Klason-Wehler 1998).

In contrast, the elimination of perfluorinated alkyl compounds was not limited by their V_{SS} , which was very low (0.19–0.37 L/kg) like those previously estimated in rats (0.5 L/kg), monkeys (0.202–0.272 L/kg), and humans (0.23 L/kg, Pizzurro et al. 2019), but by their very limited capacities of extraction. Indeed, perfluorinated alkyl substances are not known to be metabolized in the liver or other tissues (U.S. EPA 2016), and their very low elimination kinetics have been attributed to a highly efficient renal resorption of these compounds by saturable efflux transporters (Andersen et al. 2006). These polar differences need to be considered when developing a physiologically based model or for interspecies extrapolation, the factor of variability being different for V_{SS} (tissular affinity, tissue volumes, etc., Toutain and Bousquet-Mélou 2004d) and plasma clearance (affinity for plasma protein and mechanisms of intrinsic clearance that are most often metabolic (V_{max} , K_m , etc., Toutain and Bousquet-Mélou 2004b).

Conclusion

In conclusion, this TK assessment of a mixture of environmental contaminants in rabbits was able to demonstrate that animal TK studies complying with the 4R rule and analyzed by population TK modeling approach could make it easier to understand the patterns of internal exposure to contaminants that underlie their potential adverse effects. Along with mechanistic considerations, such studies could prove useful for the interspecies extrapolation of exposure rates in a TK/TD approach to risk assessment.

Acknowledgments

The authors thank F. Richard, S. Pujol and the Langlade rabbit team from the GenPhySE experimental facility for their assistance and involvement in animal care.

This work was supported by Agence Nationale de la Recherche [grant no. ANR-17-CE34-0015].

R.L., V.G., and N.P.H. conceived the project. R.L., N.P.H., and V.G. designed the experiments. J.M., R.L., V.H., and V.G. conducted the experiments. P.M. and J-P.A. performed the serum analyses. P-L.T. carried out data analysis and interpretation and

wrote the first draft of the manuscript. All coauthors provided intellectual input into the study and critically reviewed several drafts of the manuscript.

References

- Aarons L, Graham G. 2001. Methodological approaches to the population analysis of toxicity data. *Toxicol Lett* 120(1–3):405–410, PMID: 11323200, [https://doi.org/10.1016/s0378-4274\(01\)00272-7](https://doi.org/10.1016/s0378-4274(01)00272-7).
- Andersen ME, Clewell HJ, Tan Y-M, Butenhoff JL, Olsen GW. 2006. Pharmacokinetic modeling of saturable, renal resorption of perfluoroalkylacids in monkeys—probing the determinants of long plasma half-lives. *Toxicology* 227:156–164, <https://doi.org/10.1016/j.tox.2006.08.004>.
- Antignac J-P, Cariou R, Zalko D, Berrebi A, Cravedi J-P, Maume D, et al. 2009. Exposure assessment of French women and their newborn to brominated flame retardants: determination of tri- to deca- polybromodiphenylethers (PBDE) in maternal adipose tissue, serum, breast milk and cord serum. *Environ Pollut* 157:164–173, PMID: 18804904, <https://doi.org/10.1016/j.envpol.2008.07.008>.
- Assens M, Frederiksen H, Petersen JH, Larsen T, Skakkebaek NE, Juul A, et al. 2019. Variations in repeated serum concentrations of UV filters, phthalates, phenols and parabens during pregnancy. *Environ Int* 123:318–324, PMID: 30557811, <https://doi.org/10.1016/j.envint.2018.11.047>.
- Ball N, Madden J, Paini A, Mathea M, Palmer AD, Sperber S, et al. 2020. Key read across framework components and biology based improvements. *Mutat Res Genet Toxicol Environ Mutagen* 853:503172, PMID: 32522348, <https://doi.org/10.1016/j.mrgentox.2020.503172>.
- Beeson S, Webster GM, Shoeb M, Harner T, Benskin JP, Martin JW. 2011. Isomer profiles of perfluorochemicals in matched maternal, cord, and house dust samples: manufacturing sources and transplacental transfer. *Environ Health Perspect* 119(11):1659–1664, PMID: 21757419, <https://doi.org/10.1289/ehp.1003265>.
- Benet LZ, Zia-Amirhosseini P. 1995. Basic principles of pharmacokinetics. *Toxicol Pathol* 23(2):115–123, PMID: 7569664, <https://doi.org/10.1177/019262339502300203>.
- Benfenati E, Chaudhry Q, Gini G, Dorne JL. 2019. Integrating in silico models and read-across methods for predicting toxicity of chemicals: a step-wise strategy. *Environ Int* 131:105060, PMID: 31377600, <https://doi.org/10.1016/j.envint.2019.105060>.
- Bichon E, Guiffard I, Vénisseau A, Marchand P, Antignac J-P, Le Bizet B. 2015. Ultra-trace quantification method for chlordecone in human fluids and tissues. *J Chromatogr A* 1408:169–177, PMID: 26184709, <https://doi.org/10.1016/j.chroma.2015.07.013>.
- Bjerregaard-Olesen C, Bossi R, Liew Z, Long M, Bech BH, Olsen J, et al. 2017. Maternal serum concentrations of perfluoroalkyl acids in five international birth cohorts. *Int J Hyg Environ Health* 220(2 pt A):86–93, PMID: 28063899, <https://doi.org/10.1016/j.ijheh.2016.12.005>.
- Burtin P, Mentre F, van Bree J, Steimer JL. 1996. Sparse sampling for assessment of drug exposure in toxicological studies. *Eur J Drug Metab Pharmacokinet* 21(2):105–111, PMID: 8839683, <https://doi.org/10.1007/BF03190258>.
- Calafat AM, Wong L-Y, Kuklennyik Z, Reidy JA, Needham LL. 2007. Polyfluoroalkyl chemicals in the U.S. population: data from the National Health and Nutrition Examination Survey (NHANES) 2003–2004 and comparisons with NHANES 1999–2000. *Environ Health Perspect* 115(11):1596–1602, PMID: 18007991, <https://doi.org/10.1289/ehp.10598>.
- Cariou R, Veyrand B, Yamada A, Berrebi A, Zalko D, Durand S, et al. 2015. Perfluoroalkyl acid (PFAA) levels and profiles in breast milk, maternal and cord

- serum of French women and their newborns. *Environ Int* 84:71–81, <https://doi.org/10.1016/j.envint.2015.07.014>.
- Chang S-C, Noker PE, Gorman GS, Gibson SJ, Hart JA, Ehresman DJ, et al. 2012. Comparative pharmacokinetics of perfluorooctanesulfonate (PFOS) in rats, mice, and monkeys. *Reprod Toxicol* 33(4):428–440, PMID: 21889587, <https://doi.org/10.1016/j.reprotox.2011.07.002>.
- Couderc M, Poirier L, Zalouk-Vergnoux A, Kamari A, Blanchet-Letrouvé I, Marchand P, et al. 2015. Occurrence of POPs and other persistent organic contaminants in the European eel (*Anguilla anguilla*) from the Loire estuary, France. *Sci Total Environ* 505:199–215, PMID: 25461022, <https://doi.org/10.1016/j.scitotenv.2014.09.053>.
- Deceuninck Y, Bichon E, Durand S, Bemrah N, Zendong Z, Morvan ML, et al. 2014. Development and validation of a specific and sensitive gas chromatography tandem mass spectrometry method for the determination of bisphenol A residues in a large set of food items. *J Chromatogr A* 1362:241–249, PMID: 25200533, <https://doi.org/10.1016/j.chroma.2014.07.105>.
- Deceuninck Y, Bichon E, Gény T, Veyrand B, Grandin F, Vigié C, et al. 2019. Quantitative method for conjugated metabolites of bisphenol A and bisphenol S determination in food of animal origin by ultra high performance liquid chromatography–tandem mass spectrometry. *J Chromatogr A* 1601:232–242, PMID: 31097297, <https://doi.org/10.1016/j.chroma.2019.05.001>.
- Deceuninck Y, Bichon E, Marchand P, Boquien C-Y, Legrand A, Boscher C, et al. 2015. Determination of bisphenol A and related substitutes/analogues in human breast milk using gas chromatography–tandem mass spectrometry. *Anal Bioanal Chem* 407(9):2485–2497, PMID: 25627788, <https://doi.org/10.1007/s00216-015-8469-9>.
- Dimitrov S, Mekenyan O. 2010. Chapter 15: An Introduction to Read-Across for the Prediction of the Effects of Chemicals. In: *In Silico Toxicology*. Cronin M, Madden J, eds. London, UK: Royal Society of Chemistry, 372–384.
- Ettinger AS, Arbuckle TE, Fisher M, Liang CL, Davis K, Cirtiu C-M, et al. 2017. Arsenic levels among pregnant women and newborns in Canada: results from the Maternal-Infant Research on Environmental Chemicals (MIREC) cohort. *Environ Res* 153:8–16, PMID: 27880879, <https://doi.org/10.1016/j.envres.2016.11.008>.
- FDA. 1999. Guidance for Industry. Population Pharmacokinetics. <https://www.fda.gov/media/71364/download> [accessed 30 April 2019].
- Fourcot A, Feidt C, Bousquet-Mélou A, Ferran AA, Gourdière JL, Bructer M, et al. 2020. Modeling chlordecone toxicokinetics data in growing pigs using a nonlinear mixed-effects approach. *Chemosphere* 250:126151, PMID: 32092563, <https://doi.org/10.1016/j.chemosphere.2020.126151>.
- Frick LW, Adkinson KK, Wells-Knecht KJ, Woollard P, Hight DM. 1998. Cassette dosing: rapid in vivo assessment of pharmacokinetics. *Pharm Sci Technol Today* 1(1):12–18, [https://doi.org/10.1016/S1461-5347\(98\)00010-8](https://doi.org/10.1016/S1461-5347(98)00010-8).
- Gao D-W, Wen Z-D. 2016. Phthalate esters in the environment: a critical review of their occurrence, biodegradation, and removal during wastewater treatment processes. *Sci Total Environ* 541:986–1001, PMID: 26473701, <https://doi.org/10.1016/j.scitotenv.2015.09.148>.
- Gasull M, Bosch de Basea M, Puigdomènech E, Pumarega J, Porta M. 2011. Empirical analyses of the influence of diet on human concentrations of persistent organic pollutants: a systematic review of all studies conducted in Spain. *Environ Int* 37(7):1226–1235, PMID: 21683445, <https://doi.org/10.1016/j.envint.2011.05.008>.
- Gayraud V, Lacroix MZ, Grandin FC, Collet SH, Mila H, Vigié C, et al. 2019. Oral systemic bioavailability of bisphenol A and bisphenol S in pigs. *Environ Health Perspect* 127(7):77005, PMID: 31313948, <https://doi.org/10.1289/EHP4599>.
- Gentry PR, Clewell HJ 3rd, Clewell R, Campbell J, Van Landingham C, Shipp AM. 2011. Challenges in the application of quantitative approaches in risk assessment: a case study with di-(2-ethylhexyl)phthalate. *Crit Rev Toxicol* 41 (suppl 2):1–72, PMID: 21838516, <https://doi.org/10.3109/10408444.2011.599366>.
- Gerona RR, Schwartz JM, Pan J, Friesen MM, Lin T, Woodruff TJ. 2018. Suspect screening of maternal serum to identify new environmental chemical biomonitoring targets using liquid chromatography–quadrupole time-of-flight mass spectrometry. *J Expo Sci Environ Epidemiol* 28(2):101–108, PMID: 29019345, <https://doi.org/10.1038/jes.2017.28>.
- Geyer H, Scheunert I, Korte F. 1986. Bioconcentration potential of organic environmental chemicals in humans. *Regul Toxicol Pharmacol* 6(4):313–347, PMID: 3101145, [https://doi.org/10.1016/0273-2300\(86\)90002-4](https://doi.org/10.1016/0273-2300(86)90002-4).
- Haug LS, Huber S, Becher G, Thomsen C. 2011. Characterisation of human exposure pathways to perfluorinated compounds—comparing exposure estimates with biomarkers of exposure. *Environ Int* 37(4):687–693, PMID: 21334069, <https://doi.org/10.1016/j.envint.2011.01.011>.
- Hing JP, Woolfrey SG, Greenslade D, Wright PM. 2001a. Analysis of toxicokinetic data using NONMEM: impact of quantification limit and replacement strategies for censored data. *J Pharmacokinet Pharmacodyn* 28(5):465–479, PMID: 11768291, <https://doi.org/10.1023/a:1012247131190>.
- Hing JP, Woolfrey SG, Greenslade D, Wright PM. 2001b. Is mixed effects modeling or naïve pooled data analysis preferred for the interpretation of single sample per subject toxicokinetic data? *J Pharmacokinet Pharmacodyn* 28(2):193–210, PMID: 11381570, <https://doi.org/10.1023/A:1011507100493>.
- Höfer T, Gerner I, Gundert-Remy U, Liebsch M, Schulte A, Spielmann H, et al. 2004. Animal testing and alternative approaches for the human health risk assessment under the proposed new European chemicals regulation. *Arch Toxicol* 78(10):549–564, PMID: 15170526, <https://doi.org/10.1007/s00204-004-0577-9>.
- Hundley SG, Sarrif AM, Kennedy GL. 2006. Absorption, distribution, and excretion of ammonium perfluorooctanoate (APFO) after oral administration to various species. *Drug Chem Toxicol* 29(2):137–145, PMID: 16707323, <https://doi.org/10.1080/01480540600561361>.
- Johns LE, Ferguson KK, Cantonwine DE, McElrath TF, Mukherjee B, Meeker JD. 2017. Urinary BPA and phthalate metabolite concentrations and plasma vitamin D levels in pregnant women: a repeated measures analysis. *Environ Health Perspect* 125(8):087026, PMID: 28934718, <https://doi.org/10.1289/EHP1178>.
- Keswani C, Dilnashin H, Birla H, Roy P, Tyagi RK, Singh D, et al. 2021. Global footprints of organochlorine pesticides: a pan-global survey. *Environ Geochem Health*, PMID: 34027568, <https://doi.org/10.1007/s10653-021-00946-7>.
- Knutsen HK, Alexander J, Barregård L, Bignami M, Brüschweiler B, Ceccatelli S, et al. 2018. Risk to human health related to the presence of perfluorooctane sulfonic acid and perfluorooctanoic acid in food. *EFSA J* 16(12):e05194, PMID: 32625773, <https://doi.org/10.2903/j.efsa.2018.5194>.
- Kudo N, Kawashima Y. 2003. Toxicity and toxicokinetics of perfluorooctanoic acid in humans and animals. *J Toxicol Sci* 28(2):49–57, PMID: 12820537, <https://doi.org/10.2131/jts.28.49>.
- Lee W-C, Fisher M, Davis K, Arbuckle TE, Sinha SK. 2017. Identification of chemical mixtures to which Canadian pregnant women are exposed: the MIREC Study. *Environ Int* 99:321–330, PMID: 28040263, <https://doi.org/10.1016/j.envint.2016.12.015>.
- Lewin A, Arbuckle TE, Fisher M, Liang CL, Marro L, Davis K, et al. 2017. Univariate predictors of maternal concentrations of environmental chemicals: the MIREC study. *Int J Hyg Environ Health* 220(2 pt A):77–85, PMID: 28109710, <https://doi.org/10.1016/j.ijheh.2017.01.001>.
- Li M, Gehring R, Lin Z, Riviere J. 2015. A framework for meta-analysis of veterinary drug pharmacokinetic data using mixed effect modeling. *J Pharm Sci* 104(4):1230–1239, PMID: 25641543, <https://doi.org/10.1002/jps.24341>.
- Mrema EJ, Rubino FM, Brambilla G, Moretto A, Tsatsakis AM, Colosio C. 2013. Persistent organochlorinated pesticides and mechanisms of their toxicity. *Toxicology* 307:74–88, PMID: 23219589, <https://doi.org/10.1016/j.tox.2012.11.015>.
- Nedelman JR, Gibiansky E, Tse FL, Babiuk C. 1993. Assessing drug exposure in rodent toxicity studies without satellite animals. *J Pharmacokinet Biopharm* 21(3):323–334, PMID: 8258771, <https://doi.org/10.1007/BF01059783>.
- Needham LL, Burse VW, Head SL, Korver MP, McClure PC, Andrews JS, et al. 1990. Adipose tissue/serum partitioning of chlorinated hydrocarbon pesticides in humans. *Chemosphere* 20(7–9):975–980, [https://doi.org/10.1016/0045-6535\(90\)90208-B](https://doi.org/10.1016/0045-6535(90)90208-B).
- Nguyen TT, Bénech H, Pruvost A, Lenuzza N. 2016. A limited sampling strategy based on maximum a posteriori Bayesian estimation for a five-probe phenotyping cocktail. *Eur J Clin Pharmacol* 72(1):39–51, PMID: 26490357, <https://doi.org/10.1007/s00228-015-1953-5>.
- Orn U, Klasson-Wehler E. 1998. Metabolism of 2,2',4,4'-tetrabromodiphenyl ether in rat and mouse. *Xenobiotica* 28:199–211, PMID: 9522443.
- Pelch K, Wignall JA, Goldstone AE, Ross PK, Blain RB, Shapiro AJ, et al. 2019. A scoping review of the health and toxicological activity of bisphenol A (BPA) structural analogues and functional alternatives. *Toxicology* 424:152235, PMID: 31201879, <https://doi.org/10.1016/j.tox.2019.06.006>.
- Philips EM, Jaddoe VVW, Asimakopoulos AG, Kannan K, Steegers EAP, Santos S, et al. 2018. Bisphenol and phthalate concentrations and its determinants among pregnant women in a population-based cohort in the Netherlands, 2004–5. *Environ Res* 161:562–572, PMID: 29245124, <https://doi.org/10.1016/j.envres.2017.11.051>.
- Pizzurro DM, Seeley M, Kerper LE, Beck BD. 2019. Interspecies differences in perfluoroalkyl substances (PFAS) toxicokinetics and application to health-based criteria. *Regul Toxicol Pharmacol* 106:239–250, PMID: 31078680, <https://doi.org/10.1016/j.yrtph.2019.05.008>.
- Pletz J, Blakeman S, Paini A, Parissis N, Worth A, Andersson A-M, et al. 2020. Physiologically based kinetic (PBK) modelling and human biomonitoring data for mixture risk assessment. *Environ Int* 143:105978, PMID: 32763630, <https://doi.org/10.1016/j.envint.2020.105978>.
- Qiu W, Zhan H, Hu J, Zhang T, Xu H, Wong M, et al. 2019. The occurrence, potential toxicity, and toxicity mechanism of bisphenol S, a substitute of bisphenol A: a critical review of recent progress. *Ecotoxicol Environ Saf* 173:192–202, PMID: 30772709, <https://doi.org/10.1016/j.ecoenv.2019.01.114>.
- Robinson O, Basagaña X, Agier L, de Castro M, Hernandez-Ferrer C, Gonzalez JR, et al. 2015. The pregnancy exposome: multiple environmental exposures in the INMA-Sabadell birth cohort. *Environ Sci Technol* 49(17):10632–10641, PMID: 26168307, <https://doi.org/10.1021/acs.est.5b01782>.

- Scheufler E, Rozman KK. 1984. Comparative decontamination of hexachlorobenzene-exposed rats and rabbits by hexadecane. *J Toxicol Environ Health* 14(2-3):353-362, PMID: [6502739](https://pubmed.ncbi.nlm.nih.gov/6502739/), <https://doi.org/10.1080/15287398409530585>.
- Serrano SE, Braun J, Trasande L, Dills R, Sathyanarayana S. 2014. Phthalates and diet: a review of the food monitoring and epidemiology data. *Environ Health* 13(1):43, PMID: [24894065](https://pubmed.ncbi.nlm.nih.gov/24894065/), <https://doi.org/10.1186/1476-069X-13-43>.
- Sharma V, McNeill JH. 2009. To scale or not to scale: the principles of dose extrapolation. *Br J Pharmacol* 157(6):907-921, PMID: [19508398](https://pubmed.ncbi.nlm.nih.gov/19508398/), <https://doi.org/10.1111/j.1476-5381.2009.00267.x>.
- She J, Petreas M, Winkler J, Visita P, McKinney M, Kopec D. 2002. PBDEs in the San Francisco Bay area: measurements in harbor seal blubber and human breast adipose tissue. *Chemosphere* 46(5):697-707, PMID: [11999793](https://pubmed.ncbi.nlm.nih.gov/11999793/), [https://doi.org/10.1016/s0045-6535\(01\)00234-x](https://doi.org/10.1016/s0045-6535(01)00234-x).
- Sieber SM. 1976. The lymphocytic absorption of p,p'-DDT and some structurally-related compounds in the rat. *Pharmacology* 14(5):443-454, PMID: [1031215](https://pubmed.ncbi.nlm.nih.gov/1031215/), <https://doi.org/10.1159/000136627>.
- Sobol E, Bialer M. 2004. The relationships between half-life (t_{1/2}) and mean residence time (MRT) in the two-compartment open body model. *Biopharm Drug Dispos* 25(4):157-162, PMID: [15108218](https://pubmed.ncbi.nlm.nih.gov/15108218/), <https://doi.org/10.1002/bdd.396>.
- Staskal DF, Diliberto JJ, DeVito MJ, Birnbaum LS. 2005. Toxicokinetics of BDE 47 in female mice: effect of dose, route of exposure, and time. *Toxicol Sci* 83(2):215-223, PMID: [15509665](https://pubmed.ncbi.nlm.nih.gov/15509665/), <https://doi.org/10.1093/toxsci/kfi018>.
- Steimer JL, Ebelin ME, Van Bree J. 1993. Pharmacokinetic and pharmacodynamic data and models in clinical trials. *Eur J Drug Metab Pharmacokinet* 18(1):61-76, PMID: [8335040](https://pubmed.ncbi.nlm.nih.gov/8335040/), <https://doi.org/10.1007/BF03220009>.
- Sunderland EM, Hu XC, Dassuncao C, Tokranov AK, Wagner CC, Allen JG. 2019. A review of the pathways of human exposure to poly- and perfluoroalkyl substances (PFASs) and present understanding of health effects. *J Expo Sci Environ Epidemiol* 29(2):131-147, PMID: [30470793](https://pubmed.ncbi.nlm.nih.gov/30470793/), <https://doi.org/10.1038/s41370-018-0094-1>.
- Tamayo-Uria I, Maitre L, Thomsen C, Nieuwenhuijsen MJ, Chatzi L, Siroux V, et al. 2019. The early-life exposome: description and patterns in six European countries. *Environ Int* 123:189-200, PMID: [30530161](https://pubmed.ncbi.nlm.nih.gov/30530161/), <https://doi.org/10.1016/j.envint.2018.11.067>.
- Tannenbaum J, Bennett BT. 2015. Russell and Burch's 3Rs then and now: the need for clarity in definition and purpose. *J Am Assoc Lab Anim Sci* 54(2):120-132, PMID: [25836957](https://pubmed.ncbi.nlm.nih.gov/25836957/).
- Tarazona JV, Rodríguez C, Alonso E, Sáez M, González F, San Andrés MD, et al. 2016. Toxicokinetics of perfluorooctane sulfonate in rabbits under environmentally realistic exposure conditions and comparative assessment between mammals and birds. *Toxicol Lett* 241:200-206, PMID: [26562771](https://pubmed.ncbi.nlm.nih.gov/26562771/), <https://doi.org/10.1016/j.toxlet.2015.11.002>.
- Toutain PL, Bousquet-Mélou A. 2004a. Bioavailability and its assessment. *J Vet Pharmacol Ther* 27(6):455-466, PMID: [15601440](https://pubmed.ncbi.nlm.nih.gov/15601440/), <https://doi.org/10.1111/j.1365-2885.2004.00604.x>.
- Toutain PL, Bousquet-Mélou A. 2004b. Plasma clearance. *J Vet Pharmacol Ther* 27(6):415-425, PMID: [15601437](https://pubmed.ncbi.nlm.nih.gov/15601437/), <https://doi.org/10.1111/j.1365-2885.2004.00605.x>.
- Toutain PL, Bousquet-Mélou A. 2004c. Plasma terminal half-life. *J Vet Pharmacol Ther* 27(6):427-439, PMID: [15601438](https://pubmed.ncbi.nlm.nih.gov/15601438/), <https://doi.org/10.1111/j.1365-2885.2004.00600.x>.
- Toutain PL, Bousquet-Mélou A. 2004d. Volumes of distribution. *J Vet Pharmacol Ther* 27(6):441-453, PMID: [15601439](https://pubmed.ncbi.nlm.nih.gov/15601439/), <https://doi.org/10.1111/j.1365-2885.2004.00602.x>.
- US EPA (US Environmental Protection Agency). 2016. Drinking water health advisories for PFOA and PFOS. US Environmental Protection Agency. <https://www.epa.gov/ground-water-and-drinking-water/drinking-water-health-advisories-pfoa-and-pfos> [accessed 28 May 2020].
- Vrijheid M, Martinez D, Aguilera I, Ballester F, Basterrechea M, Esplugues A, et al. 2012. Socioeconomic status and exposure to multiple environmental pollutants during pregnancy: evidence for environmental inequity? *J Epidemiol Community Health* 66(2):106-113, PMID: [20974841](https://pubmed.ncbi.nlm.nih.gov/20974841/), <https://doi.org/10.1136/jech.2010.117408>.
- Wang Y, Zhu H, Kannan K. 2019. A review of biomonitoring of phthalate exposures. *Toxics* 7(2):21, PMID: [30959800](https://pubmed.ncbi.nlm.nih.gov/30959800/), <https://doi.org/10.3390/toxics7020021>.
- White RE, Manitpisitkul P. 2001. Pharmacokinetic theory of cassette dosing in drug discovery screening. *Drug Metab Dispos* 29(7):957-966, PMID: [11408361](https://pubmed.ncbi.nlm.nih.gov/11408361/).
- WHO (World Health Organization). 1992. *Alpha- and beta- hexachlorocyclohexanes/ published under the joint sponsorship of the United Nations Environment Programme, the International Labour Organisation, and the World Health Organization*. <https://apps.who.int/iris/handle/10665/37502> [accessed 9 November 2020].
- WHO. 2003. *Health risks of persistent organic pollutants from long-range transboundary air pollution*. <https://apps.who.int/iris/handle/10665/107471> [accessed 17 December 2020].
- Wilson RL, Bianco-Miotto T, Leemaqz SY, Grzeskowiak LE, Dekker GA, Roberts CT. 2018. Early pregnancy maternal trace mineral status and the association with adverse pregnancy outcome in a cohort of Australian women. *J Trace Elem Med Biol* 46:103-109, PMID: [29413099](https://pubmed.ncbi.nlm.nih.gov/29413099/), <https://doi.org/10.1016/j.jtemb.2017.11.016>.
- Woods MM, Lanphear BP, Braun JM, McCandless LC. 2017. Gestational exposure to endocrine disrupting chemicals in relation to infant birth weight: a Bayesian analysis of the HOME study. *Environ Health* 16(1):115, PMID: [29078782](https://pubmed.ncbi.nlm.nih.gov/29078782/), <https://doi.org/10.1186/s12940-017-0332-3>.
- Wu Z, He C, Han W, Song J, Li H, Zhang Y, et al. 2020. Exposure pathways, levels and toxicity of polybrominated diphenyl ethers in humans: a review. *Environ Res* 187:109531, PMID: [32454306](https://pubmed.ncbi.nlm.nih.gov/32454306/), <https://doi.org/10.1016/j.envres.2020.109531>.
- Wu L-H, Zhang X-M, Wang F, Gao C-J, Chen D, Palumbo JR, et al. 2018. Occurrence of bisphenol S in the environment and implications for human exposure: a short review. *Sci Total Environ* 615:87-98, PMID: [28963899](https://pubmed.ncbi.nlm.nih.gov/28963899/), <https://doi.org/10.1016/j.scitotenv.2017.09.194>.