



**HAL**  
open science

## Habitat suitability map of *Ixodes ricinus* tick in France using multi-criteria analysis

Isabelle Lebert, Severine Bord, Christine Saint-Andrieux, Eva Cassar, Patrick Gasqui, Frédéric Beugnet, Karine Chalvet-Monfray, Sophie Vanwambeke, Gwenaël Vourc'h, Magalie René-Martellet

► **To cite this version:**

Isabelle Lebert, Severine Bord, Christine Saint-Andrieux, Eva Cassar, Patrick Gasqui, et al.. Habitat suitability map of *Ixodes ricinus* tick in France using multi-criteria analysis. *Geospatial Health*, 2022, 17, 10.4081/gh.2022.1058 . hal-03672090

**HAL Id: hal-03672090**

**<https://hal.inrae.fr/hal-03672090>**

Submitted on 19 May 2022

**HAL** is a multi-disciplinary open access archive for the deposit and dissemination of scientific research documents, whether they are published or not. The documents may come from teaching and research institutions in France or abroad, or from public or private research centers.

L'archive ouverte pluridisciplinaire **HAL**, est destinée au dépôt et à la diffusion de documents scientifiques de niveau recherche, publiés ou non, émanant des établissements d'enseignement et de recherche français ou étrangers, des laboratoires publics ou privés.



Distributed under a Creative Commons Attribution - NonCommercial 4.0 International License

# Habitat suitability map of *Ixodes ricinus* tick in France using multi-criteria analysis

Isabelle Lebert,<sup>1,2</sup> Séverine Bord<sup>1,3</sup> Christine Saint-Andrieux,<sup>4</sup> Eva Cassar,<sup>1,2</sup> Patrick Gasqui,<sup>1,2</sup> Frédéric Beugnet,<sup>5</sup> Karine Chalvet-Monfray,<sup>1,2</sup> Sophie O. Vanwambeke,<sup>6</sup> Gwenaël Vourc'h,<sup>1,2</sup> Magalie René-Martellet<sup>1,2</sup>

<sup>1</sup>University of Clermont Auvergne, National Research Institute for Agriculture, Food, and the Environment, VetAgro Sup, UMR EPIA, Saint-Genès Champanelle, France; <sup>2</sup>University of Lyon, National Research Institute for Agriculture, Food, and the Environment, VetAgro Sup, UMR EPIA, Marcy l'Etoile, France; <sup>3</sup>University of Paris-Saclay, National Research Institute for Agriculture, Food, and the Environment, AgroParisTech, UMR MIA-Paris, Paris, France; <sup>4</sup>French Biodiversity Office, Gerstheim, France; <sup>5</sup>Boehringer Ingelheim, Lyon, France; <sup>6</sup>Georges Lemaître Centre for Earth and Climate research, Earth & Life Institute, UCLouvain, Louvain-la-Neuve, Belgium

Correspondence: Isabelle Lebert, University of Clermont Auvergne, National Research Institute for Agriculture, Food, and the Environment (INRAE), VetAgro Sup, UMR EPIA, F-63122 Saint-Genès Champanelle, France. Tel.: +33.473.624671. E-mail: isabelle.lebert@inrae.fr

Key words: *Ixodes ricinus*; habitat suitability mapping; climate; land cover; wild ungulate, France.

Acknowledgements: we thank the National Federation of Hunters (*Fédération Nationale des Chasseurs*) for providing data. We gratefully acknowledge the National Research Institute for Agriculture, Food, and the Environment (INRAE); VetAgro Sup; the French National Centre for Scientific Research (CNRS); Boehringer Ingelheim; the French National Research Agency; and IDEX-ISITE for their scientific and financial support of the projects that provided the data used in this work. The CCEID project was supported by the Adaptation of Agriculture and Forests to Climate Change (AAFCC) metaprogramme of INRA and Boehringer Ingelheim; the OSCAR project was supported by a grant from the French National Research Agency (ANR-11Agro-001-04, Call for Proposal 'Agrobiosphere'); and the TELETIQ project was financed by the French government's IDEX-ISITE initiative 16-IDEX-0001 (CAP 20-25). We also thank Julie Cat for her scientific contribution and Lindsay Higgins for her English language revisions.

Contributions: MRM, conceptualisation, writing-original draft, review and editing; IL, methodology, data curation, GIS, writing-original draft, review and editing; SB, methodology, statistics, validation, writing, review and editing; SV, methodology, writing, review and editing; GV, writing, review and editing; CSA, resources, writing, review and editing; PG, methodology, statistics; EC, methodology, data curation, writing; FB, resources, writing, review and editing; KCM, writing, review and editing.

Conflict of interest: the authors declare no potential conflict of interest.

See online Appendix for additional Figures.

Received for publication: 22 November 2021.

Revision received: 13 April 2022.

Accepted for publication: 14 April 2022.

©Copyright: the Author(s), 2022

Licensee PAGEPress, Italy

Geospatial Health 2022; 17:1058

doi:10.4081/gh.2022.1058

This article is distributed under the terms of the Creative Commons Attribution Noncommercial License (CC BY-NC 4.0) which permits any noncommercial use, distribution, and reproduction in any medium, provided the original author(s) and source are credited.

Publisher's note: All claims expressed in this article are solely those of the authors and do not necessarily represent those of their affiliated organizations, or those of the publisher, the editors and the reviewers. Any product that may be evaluated in this article or claim that may be made by its manufacturer is not guaranteed or endorsed by the publisher.

## Abstract

The tick *Ixodes ricinus* is widely distributed across Europe and is responsible for the transmission of several pathogens to humans and animals. In this study, we used a knowledge-based method to map variations in habitat suitability for *I. ricinus* ticks throughout continental France and Corsica. The multi-criteria decision analysis (MCDA) integrated four major biotic and abiotic factors known to influence tick populations: climate, land cover, altitude and the density of wild ungulates. For each factor, habitat suitability index (HSI) values were attributed to different locations based on knowledge regarding its impact on tick populations. For the MCDA, two methods of factor combination were tested, additive and multiplicative, both which were evaluated at the spatial scales of departments and local municipalities. The resulting habitat suitability maps (resolution=100x100 m) revealed that conditions are suitable for *I. ricinus* over most of France and Corsica. Particularly suitable habitats were located in central, north-eastern and south-western France, while less-suitable habitats were found in the Mediterranean and mountainous regions. To validate the approach, the HSI scores were compared to field data of *I. ricinus* nymph abundance. Regardless of scale, the correlation between abundance indicator and HSI score was stronger for the additive than for the multiplicative approach. Overall, this study demonstrates the value of MCDA for estimating habitat suitability maps for *I. ricinus* abundance, which could be especially useful in highlighting areas of the tick's distribution where preventive measures should be prioritised.

## Introduction

*Ixodes ricinus*, the most abundant and widely distributed tick species in Europe (Alfredsson *et al.*, 2017; Semenza and Suk, 2018), is responsible for the transmission of several pathogens of medical importance, including the parasite *Babesia divergens*, the bacteria *Borrelia burgdorferi* s.l. and *Anaplasma phagocytophilum* and the virus responsible for tick-borne encephalitis (TBE) (Bonnet *et al.*, 2016). The bacteria of the *B. burgdorferi* species complex are of particular importance because they are responsible for human Lyme disease (borreliosis). The annual incidence of this disease in France was estimated in 2020 to be between 52,990 and 67,076 cases per year (Réseau sentinelles, 2021). Considering the number of human Lyme infections in



Europe and the importance of *I. ricinus* for transmission, there is a need for accurate assessments of the risk of exposure to and transmission of the pathogen. Thus, it is first necessary to have knowledge of the distribution of *I. ricinus* and of the areas suitable for its development.

*I. ricinus* is an exophilic and ubiquitous species whose life cycle consists of three life stages: larva, nymph, and adult (Agoulon *et al.*, 2016; Bonnet *et al.*, 2016). *I. ricinus* development and questing depend on both biotic and abiotic conditions (Uusitalo *et al.*, 2020). The wide variety of climatic conditions found in France (Joly *et al.*, 2010; Mûcher *et al.*, 2010), particularly with respect to humidity and temperature, are suitable for these ticks across the majority of the territory (Beugnet *et al.*, 2009; Wongnak *et al.*, 2022b). An exception is in the area around the Mediterranean basin, where the hot and dry climate is generally considered unsuitable for the species (Gilot *et al.*, 1996; Estrada-Peña and Venzal, 2007) because of its vulnerability to desiccation at all life stages (Lees, 1946; Wongnak *et al.*, 2022a). *I. ricinus* can be encountered in many types of vegetation, but the species is more widespread in forests and wooded areas because these environments offer conditions that favour its development (Swart *et al.*, 2014; Boehnke *et al.*, 2015; Vanwambeke *et al.*, 2016; Hönig *et al.*, 2019). In continental France and neighbouring countries, tick abundance is generally higher in the presence of deciduous trees such as oaks than in the presence of coniferous ones (Tack *et al.*, 2012; Boehnke *et al.*, 2015; Vourc'h *et al.*, 2016). The species has also been detected in suburban forests and public parks visited by humans and domestic animals, as well as in private gardens (Maetzel *et al.*, 2005; Paul *et al.*, 2016b; Vourc'h *et al.*, 2016). Although altitude does not have a direct effect on *I. ricinus*' development, it influences both climate and vegetation type. High densities of this tick species have been reported up to an altitude of 1000 metres above sea level (asl) (Daniel *et al.*, 2016b; Taragel'ova *et al.*, 2016; De Pelsmaecker *et al.*, 2021). However, many studies have shown that tick densities decrease with increasing altitude, with a sharper decrease above 1000 m asl (Materna *et al.*, 2008; Danielova *et al.*, 2010; Ragagli *et al.*, 2016; Taragel'ova *et al.*, 2016; Sandor *et al.*, 2017). Since 2003, expansions in the distribution of ticks have been observed up to 1100 m asl in the Czech Republic and Switzerland (Daniel *et al.*, 2003; Cadenas *et al.*, 2007), up to 1250 m asl in Slovakia and the Czech Republic (Materna *et al.*, 2008; Taragel'ova *et al.*, 2016), and up to 1800 m asl in the French Pyrenees (Akl *et al.*, 2019). The development and local abundance of *I. ricinus* ticks are linked with the wide variety of vertebrate hosts on which they engorge. In particular, the density of wild ungulates has been found to affect the local densities of *I. ricinus* and the risk of tick-borne disease transmission (Gilbert *et al.*, 2012; Radolf *et al.*, 2012; Vourc'h *et al.*, 2016; Fabri *et al.*, 2021). Roe deer, specifically, play an important role in the developmental cycle of ticks, with multiple studies demonstrating a significant correlation between roe deer population density and tick abundance (Medlock *et al.*, 2013; Chen *et al.*, 2015; Hofmeester *et al.*, 2017; Mysterud *et al.*, 2021). Several other hosts may also affect tick development and abundance: rodents (Perez *et al.*, 2016; Martello *et al.*, 2019), birds (Klitgaard *et al.*, 2019), lizards (Rizzoli *et al.*, 2014) and local densities of chipmunks (Vourc'h *et al.*, 2016) can all play a role in sustaining populations of larvae and nymphs.

Even though the major factors affecting the *I. ricinus* life cycle are well identified, their combined effect on the distribution of this tick in France has been poorly described. Mapping the distribution

or abundance of ticks remains a challenging task. Although previous surveys have confirmed its presence in several regions of France, in other areas it is not always clear if a lack of abundance data reflects the fact that surveys have not yet been conducted or, alternatively, that surveys were done but failed to detect this species. Furthermore, there is a general paucity of data on variations in abundance from one place to another at national, regional, or local scales. Large-scale sampling studies are often not feasible because of the time, money and human resources needed. Efforts have been made to estimate the distribution or abundance of *I. ricinus*: i) at the European scale (Estrada-Peña *et al.*, 2006; Beugnet *et al.*, 2009; Medlock *et al.*, 2013; Cat *et al.*, 2017; Li *et al.*, 2019); ii) at the national scale in the Netherlands (Swart *et al.*, 2014), Ireland (Rousseau *et al.*, 2017) and Germany (Brugger *et al.*, 2016); and iii) at the regional or local scale in Germany (Boehnke *et al.*, 2015; Zubriková *et al.*, 2020), the Czech Republic (Daniel *et al.*, 2016a) and Slovakia (Taragel'ova *et al.*, 2016). In France, there is a real need for mapping the variations of *I. ricinus*' abundance at different scales. Information at the national and regional scale is needed to highlight regions where preventive measures, such as publicity campaigns should be prioritised. Data at the local scale can be used for the design of local action plans aimed at limiting the conditions for tick development and communicating the risks to the general public.

One method that has been used in various applications to assess the environmental suitability of an area is multi-criteria decision analysis (MCDA), associated with a geographic information systems (GIS)-based approach (Estoque and Murayama, 2010; Chen *et al.*, 2015). By combining the major factors that influence a problem, it generates information that can help decision-making or identifying suitable locations (Hongoh *et al.*, 2011). It has the advantage of being easily adaptable to different situations and scales. The usefulness of this method has recently been confirmed for predicting habitat suitability for ticks, including *Ornithodoros* (Vial *et al.*, 2018) and *I. ricinus* in the Czech Republic, Ireland and regions around the Czech/German border (Hönig *et al.*, 2011; Rousseau *et al.*, 2017; Svec *et al.*, 2019), but it has not yet been used for this purpose in France.

The objective of this study was to map the abundance of *I. ricinus* in continental France and Corsica using an MCDA approach that combines the main factors known to influence the survival and development of the tick species: climate, land cover, altitude and the density of wild ungulate hosts. For each level of these factors, habitat suitability indices (HSI) were attributed and the values combined to obtain HSI scores using MCDA methods based on additive or multiplicative approaches. The analysis was carried out at two spatial scales, the scale of local municipalities and that of larger departments that would reflect differences in the resolution of datasets available for roe deer and wild boar.

## Materials and methods

### The multi-criteria decision analysis method

The method used in this study was adapted from previously published MCDA procedures (Malczewski, 2000; Pfeiffer *et al.*, 2008; Hongoh *et al.*, 2011). The steps were: i) identification of georeferenced factors influencing the abundance of *I. ricinus* ticks with HSI values attributed for the levels of each factor; ii) standardisation of the spatial layers to achieve equal pixel size and res-

olution and normalisation to a scale of 0 to 1; iii) calculation of the HSI score by combining the HSI values of the factors with additive and multiplicative approaches attributing weights to each factor in the additive method (Ishizaka and Nemery, 2013); iv) mapping the habitat suitability for *I. ricinus* ticks in continental France and Corsica based on HSI scores; and v) validation of the HSI scores through comparison with field data on *I. ricinus* nymph abundance.

### Factors and data selection

We identified the main factors influencing the development and abundance of *I. ricinus* from the literature: climate, land cover, altitude and ungulate densities. These variables were chosen both for their strong influence on tick development as well as the availability and reliability of data in France. Climate zone data were obtained from the European Landscape Classification scheme (LANMAP3) (Mücher *et al.*, 2010) at 1000-m spatial resolution extracted from the Environmental Classification of Europe (EnC),

which is based on the statistical clustering of climatic and topographic variables (Metzger *et al.*, 2005). The EnC classification distinguishes 13 climate zones in Europe based on five main climatic variables - temperature, precipitation, percentage of sunshine, vapour pressure and the daily temperature range - as well as oceanicity, latitude and altitude. In the EnC, altitude was used only to distinguish the Mediterranean mountainous zone (areas above 1000 m asl) from the northern and southern Mediterranean zones, and this does not interfere with the altitude factor used elsewhere.

Land use data were provided by the CORINE Land Cover 2018 dataset (European Environment Agency, CLC2018) at 100-m spatial resolution (Table 1). Altitude data were obtained from the digital elevation model (BD ALTI®, Version 2.0; <https://geoservices.ign.fr/bdalti>) at 250-m resolution created by 'Institut National de l'Information Géographique et Forestière' (IGN-F, <http://www.ign.fr/>). Estimates of wild ungulate densities were obtained from the 'Office Français de la Biodiversité' (OFB) and the 'Fédération Nationale des Chasseurs' (FNC) (Saint-Andrieux

**Table 1. Habitat suitability index for *I. ricinus* ticks based on type of land cover.**

Nomenclature (CLC2018)	<i>HSI<sub>Land</sub></i>
- Continuous urban fabric (111), industrial or commercial units (121), port areas (123), mineral extraction sites (131), construction sites (133), rice fields (213)	0
- Sclerophyllous vegetation (323), beaches, dunes, sands (331), bare rocks (332), burnt areas (334), glaciers and perpetual snow (335), salt marshes (421), salines (422), intertidal flats (423)	
- Water courses (511), water bodies (512), coastal lagoons (521), estuaries (522), sea and ocean (523)	
- Road and rail networks and associated land (122), airports (124), dump sites (132), green urban areas (141), sport and leisure facilities (142)	0.25
- Vineyards (221), olive groves (223), annual crops associated with permanent crops (241)	
- Sparsely vegetated areas (333)	
- Discontinuous urban fabric (112)	0.5
- Non-irrigated arable land (211), permanently irrigated land (212), complex cultivation patterns (242)	
- Coniferous forest (312)	
- Inland marshes (411), peat bogs (412)	
- Fruit trees and berry plantations (222), pastures (231), land principally occupied by agriculture, with significant areas of natural vegetation (243)	0.75
- Natural grasslands (321), moors and heath land (322), transitional woodland-shrub (324)	
- Agro-forestry areas (244)	1
- Broad-leaved forest (311), mixed forest (313)	

CLC2018, third level of the CORINE land cover classification; *HSI<sub>Land</sub>* habitat suitability index for land features, an indicator that varies from 0 (weak habitat suitability) to 1 (very high habitat suitability).

**Table 2. Wild ungulate data used in the models.**

Type of ungulate	Year of data collection	Geographical unit (km <sup>2</sup> )	Proxy for the animal number
Red deer ( <i>Cervus elaphus</i> )	2010	Distribution area*	Hunting bag <sup>o</sup>
Sika deer ( <i>Cervus Nippon</i> )	2013	Spatial domain <sup>†</sup>	Hunting bag
Fallow deer ( <i>Dama dama</i> )	2013	Spatial domain	Hunting bag
Alpine ibex ( <i>Capra ibex</i> )	2010	Distribution area	Estimated minimum number <sup>§</sup>
Corsican mouflon ( <i>Ovis gmelini musimon var. corsicana</i> )	2010	Distribution area	Estimated minimum number
Mediterranean mouflon ( <i>Ovis gmelini musimon x Ovis sp</i> )	2010	Distribution area	Estimated minimum number
Pyrenean chamois ( <i>Rupicapra pyrenaica</i> )	2010	Distribution area	Estimated minimum number
Alpine chamois ( <i>Rupicapra rupicapra</i> )	2010	Distribution area	Estimated minimum number
Wild boar ( <i>Sus scrofa</i> ) <sup>^</sup>	2010 to 2014	Department or municipalities <sup>§</sup>	Killed animals
Roe deer ( <i>Capreolus capreolus L.</i> ) <sup>^</sup>	2002-2007-2012	Department or municipalities <sup>§</sup>	Hunting bag

\*The entire zone where a species is present as determined by expert opinion; <sup>o</sup>the number of animals killed by a legal hunter; <sup>†</sup>a georeferenced hunting unit in which there is hunting activity and where wildlife populations are monitored; the population data are based on the number of animals killed; <sup>§</sup>as estimated by expert opinion (National Federation of Hunters, Office Français de la Biodiversité); <sup>^</sup>animals present throughout the whole country; numbers tracked by each department (regional administrative unit of France). Species numbers for each department and municipality were calculated as the mean of five years (from 2010 to 2014) for wild boar and as the mean of three years (2002, 2007 and 2012) for roe deer; <sup>§</sup>data available for all French departments, but not for all French municipalities (see Figure 4).





and Barboiron, 2014) (Table 2). The dataset for each ungulate species differed slightly depending on whether the animal is hunted or protected, the geographical location(s) in which it is found and the areas in which it is monitored (hunting area or conservation area). The national data for wild boar and roe deer were available from the OFB at two spatial levels: the French administrative departments (n=96) and the French administrative municipalities (n=34,970 in 2019). Numbers of other wild ungulates were given in locally georeferenced areas; absence of a geographical area indicates the absence of the species in that area.

### Habitat suitability indices attribution for each factor

For climate and land cover, HSI values were attributed based on a literature review (Beugnet *et al.*, 2009; Hönig *et al.*, 2011; Estrada-Peña *et al.*, 2013; Swart *et al.*, 2014; Zeimes *et al.*, 2014). HSI values for each factor were all in the same format and on a comparable scale of 0 to 1.

In France, 9 of the 13 zones of the environmental classification of Europe are present: Nemoral, Alpine South, Continental, Atlantic Central, Pannonian, Lusitanian, Mediterranean mountains, Mediterranean North and Mediterranean South. Among them, only one climate (Mediterranean South) was considered as weakly suitable for ticks. Because of its generally higher temperatures and lower relative humidity, it was assigned a value of 0, while a value of 1 (high suitability) was assigned to the other eight climate types (Table 3).

As shown in Table 1, land cover classes were also assigned HSI values ranging from 0 to 1, *i.e.* the least to the most suitable for *I. ricinus*. We attributed high suitability indices to forest areas, broad-leaved and mixed forest and to some agricultural areas as indicated by Beugnet *et al.* (2009), Swart *et al.* (2014) and the European Centre for Disease Prevention (ECDC, 2019). Intermediate or low habitat suitability indices were attributed to urban areas (discontinuous urban fabric, green urban areas, sport and leisure facilities), agricultural areas (fruit trees, vineyards, arable land) and wetlands (marshes and peat bogs), which comprise all areas in which ticks have been found (Swart *et al.*, 2014; Hansford *et al.*, 2017; Lejal *et al.*, 2019; Mathews-Martin *et al.*, 2020). A value of zero was assigned to areas with no vegetation.

As high densities of *I. ricinus* have been reported up to an altitude of 1000 m asl, the associated HSI was set to 1 for sites below this altitude. From 1000 to 2000 m asl, were given sharply decreasing HSI values using a continuous function described by Derringer and Suich (1980) (Table 4). Above 2000 m asl, the HSI was set to zero.

Ungulate density was approximated as the number of animals counted over a given area, because it is not possible to know with absolute certainty the number of wild animals present in an area (Aubry and Guillemain, 2019). For all counting areas, the proxy values were converted into a range from 0 to 1 to obtain the HSI indices (Table 2). HSI values from 0 to 1 were given by separating the 10 ungulate species into three groups for further analysis: i) roe deer; ii) wild boar; and iii) a group composed of red deer, sika deer, fallow deer, alpine ibex, Corsican and Mediterranean mouflons including Alpine and Pyrenean chamois. The eight ungulates in this last group had noticeably lower densities than roe deer and wild boar. Furthermore, they were not distributed throughout the whole territory and were instead present only in isolated regions of varying surface area; for example, Pyrenean chamois are only found in the Pyrenees, while Alpine chamois are located in the Alps.

## *I. ricinus* habitat suitability mapping

### Generating standardised map layers and the global constraint map

All data were imported into the ArcGIS Pro geographic information system version 2.8.2 (ESRI Inc. Redlands, CA, USA) and converted to rasters at a resolution of 100 m to enable map combination. A constraint layer was created for the following three factors: climate; land cover; and altitude. Factors considered unsuitable for *I. ricinus* (*e.g.*, Mediterranean South climate, continuous urban fabric, lakes and rivers and altitudes above 2000 m asl) were attributed a zero value for each pixel (HSI=0). A value of 1 was attributed for all other suitable variables. No constraint layer was prepared for the proxy of wild ungulates as we did not want to make assumptions about the absence of ticks based on the absence of ungulates. The global binary constraint map resulted from the multiplication of the three constraint layers for climate, land cover and altitude. It was given an HSI = 0 if any one of the three factors had this value; HSI was equal to 1 in all other areas. All HSI map layers were multiplied by the global binary constraint map (Figure 1) and standardised so that the minimum and maximum values of the score were 0 and 1, respectively (Malczewski, 2000).

### Combinations of standardised map layers

Two combination approaches were tested (Figure 1). The HSI values of the four factors were either: i) added using the weighted linear combination (WLC) method (Malczewski, 2000; Pfeiffer *et al.*, 2008); or ii) all multiplied together (Ishizaka and Nemery, 2013). Both approaches were applied at two geographic scales, departmental and municipal, using the different datasets for roe deer and wild boar. The resulting global HSI was named the HSI score.

In the additive approach, the four raster layers (climate;land cover;altitude;and wild ungulate density) were combined with equal weight (Equation 1) to give the same importance to each

**Table 3. Suitability levels of *I. ricinus* ticks based on climate in the different zones of France.**

Climate zone	$HSI_{Clim}$
Nemoral	1
Alpine South	1
Continental	1
Atlantic Central	1
Pannonian	1
Lusitanian	1
Mediterranean Mountains	1
Mediterranean North	1
Mediterranean South	0

$HSI_{Clim}$ , habitat suitability index for climate zones (Metzger *et al.*, 2005), an indicator that varies from 0 (weak suitability) to 1 (very high suitability).

**Table 4. Habitat suitability index for *I. ricinus* ticks based on altitude.**

Altitude range	$HSI_{Alt}$
≤1000 m	1
1000-2000 m asl*	$[(2000 - ALT) / (2000 - 1000)]^{7*}$
>2000 m asl	0

$HSI_{Alt}$ , habitat suitability index for altitudes, an indicator that varies from 0 (weak suitability) to 1 (very high suitability); asl, above sea level; ALT, altitude (m). \*Desirability function (Derringer and Suich, 1980).

layer. The sum of the weights was equal to 1:

$$HSI^{add} = \frac{1}{4} HSI_{Clim} + \frac{1}{4} HSI_{Land} + \frac{1}{4} HSI_{Alt} + \frac{1}{4} HSI_{Ung} \quad (1)$$

where  $HSI^{add}$  is the HSI score calculated with the additive method;  $HSI_{Clim}$  the HSI associated with climate;  $HSI_{Alt}$  the HSI associated with altitude; and  $HSI_{Ung}$  the HSI associated with wild ungulate density.

$$HSI_{Ung} = \frac{1}{3} HSI_{Deer} + \frac{1}{3} HSI_{Boar} + \frac{1}{3} HSI_{8Ung} \quad (2)$$

In a similar way, Equation 2 gives the weights for the animals where the  $HSI_{Deer}$  is the HSI associated with roe deer;  $HSI_{Boar}$  the HSI associated with wild boar; and  $HSI_{8Ung}$  the HSI associated with the eight other wild ungulates.  $HSI_{8Ung}$  is calculated as the mean HSI of these eight species, *i.e.* the sum of the HSI values of the ungulate species present divided by the number of ungulate species present at a given pixel.

In the multiplicative approach, the four raster layers were multiplied according to Equation 3:

$$HSI^{mx} = HSI_{Clim} \cdot HSI_{Land} \cdot HSI_{Alt} \cdot HSI_{Ung_m} \quad (3)$$

with  $HSI_{Ung_m} = \frac{1}{3} HSI_{Deer} + \frac{1}{3} HSI_{Boar} + \frac{1}{3} HSI_{8Ung}$  (4)

where  $HSI^{mx}$  is the HSI score derived from the multiplicative method and  $HSI_{Ung_m}$  the HSI associated with wild ungulate density. The last layer in Equation 4 ( $HSI_{Ung_m}$ ) differed from that used in the additive method by the zero values being replaced by the minimum value above zero, defined as the first  $HSI_{Ung} > 0$ .

Based on the wild boar and roe deer datasets available for the two administrative levels - departmental and municipal - four maps representing HSI scores were calculated: additive approach using

the departmental or municipal datasets ( $HSI_{dpt}^{add}$ ,  $HSI_{mun}^{add}$ ) and multiplicative approach with each dataset ( $HSI_{dpt}^{mx}$ ,  $HSI_{mun}^{mx}$ ).

The resulting habitat suitability maps had a resolution of 100x100 m. The threshold values of the classes for the four HSI scores were obtained using the Jenks natural breaks classification method.

### Comparison of habitat suitability index for *I. ricinus* to field data

To validate the estimates of habitat suitability for *I. ricinus*, the HSI scores were compared to field data on nymph abundance generated using the dragging method (Vassallo *et al.*, 2000). To ensure that all data were comparable, we obtained abundance data from several projects conducted in France by the Epidemiology of Animal and Zoonotic Diseases (EPIA) Joint Research Unit (Table 5, Figure 2); all surveys were carried out from April to June with

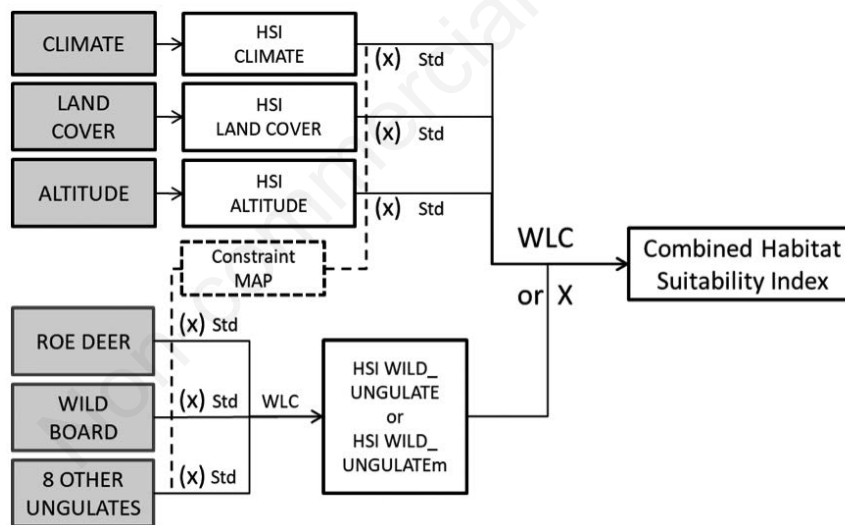

**Figure 1.** Schematic presentation of the methodology used to calculate the combined habitat suitability index (HSI) score for tick presence. WLC, weighted linear combination and indicates the use of addition; X indicates the use of multiplication; Text in grey boxes indicates raw data; text in white boxes indicates data converted into HSI; Std, standardisation; (x), multiplication by binary constraint map.

**Table 5.** Datasets of estimated abundance of *I. ricinus* ticks from the field in France.

Project acronym	Site sites*	Collection year(s)	Tick sampling method°	Area	Reference
CCEID	S1- S11	2014-2020	Dragging once a month	France	Wongnak <i>et al.</i> (2020)
TELETIQ	H1-H12 H14-H16	2018	Dragging one sampling per month (April to June)	Auvergne-Rhône-Alpes	Bord <i>et al.</i> (2019)
OSCAR	O1-O2	2012-2015	Dragging spring	North-western, South-western	Lebert <i>et al.</i> (2020)

\*Shown in Figure 2; °observation units of all projects corresponded to 10 m<sup>2</sup> surface area. S1, La Tour De Salvagny (two locations S1a and S1b); S2, Saint-Genès-Champanelle; S3, Restinclière; S4, Etiolles; S5, Carquefou; S6, Gardouch (within deer park); S7, Gardouch (outside deer park); S8, Velaine-en-Haye; S9 to S11, Les Bordes; H1, Coustansouze; H2, Marcenat; H3, Noailly; H4, Quincie-en-Beaujolais; H5, Volvic; H6, Sermentizon; H7, Panisnières; H8, La Tour de Salvagny; H9, Montboudif; H10, Saint-Germain L'Herm; H11, Chambles; H12, Pelussin; H14, Saint-Georges; H15, Cayres; H16, Champclausse; LTER, long term ecological research: O1, LTER «Zone atelier Pyrénées Garonne» site (two locations O1a and O1b); O2, LTER «Zone Armorique» site (two locations O2a and O2b).

the same sampling method. For all selected survey locations, the observation unit was defined as an area of 10m<sup>2</sup> and the observed abundance was the number of nymphs collected using the drag sampling method. From the field data, six abundance indicators were calculated: i) the mean; and ii) the median number of nymphs collected per observed unit in each site (n=31 sites) plus (iii to vi), *i.e.* the proportions of observation units in which no nymphs were

collected (p<sub>zero</sub>); 1-10 (p<sub>1\_10</sub>); 11-50 nymphs (p<sub>11\_50</sub>); and >50 nymphs (p<sub>>50</sub>). For each site location, the corresponding HSI score values were extracted from the four models.

To assess the relationship between HSI scores and abundance indicators, Spearman's rank correlation, rho, was used (R Core Team, 2017). This is a nonparametric measure that avoids the assumption that variables have a normal distribution. Spearman's

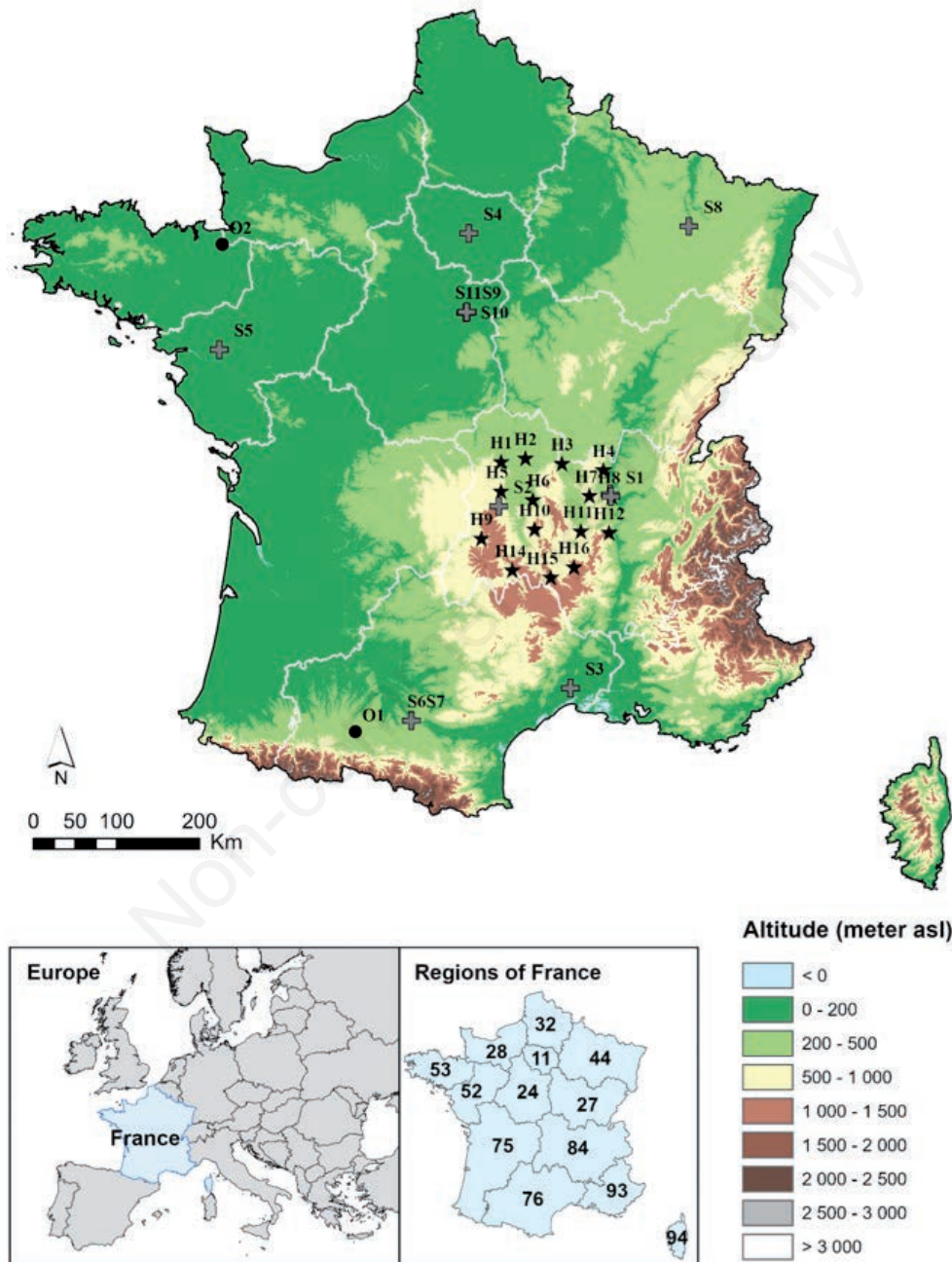

Figure 2. Locations of sampling sites during the field surveys of *I. ricinus* populations used for comparison to habitat suitability index scores. + = CC-EID project; ★ = TELETIQ project; ● = OSCAR project (site descriptions in Table 5). Background map sources: BD ALTI®, GEOFLA® (IGN-F). Region codes and names: 11: Île-de-France (Île-de-France); 24: Centre-Loire Valley (Centre-Val de Loire); 27: Burgundy-Franche-Comté (Bourgogne-Franche-Comté); 28: Normandy (Normandie); 32: Hauts-de-France (Hauts-de-France); 44: Grand Est (Grand Est); 52: Pays de la Loire (Pays de la Loire); 53: Brittany (Bretagne); 75: New Aquitaine (Nouvelle-Aquitaine); 76: Occitania (Occitanie); 84: Auvergne-Rhône-Alpes (Auvergne-Rhône-Alpes); 93: Provence-Alpes-Côte d’Azur (Provence-Alpes-Côte d’Azur); 94: Corsica (Corse).



rho can have any value between  $-1$  and  $+1$ . A value of  $0$  indicates no relationship and values of  $+1$  or  $-1$  indicate a one-to-one relationship between the variables ('perfect correlation'). Because Spearman's rho is based on ranked values rather than original measurements, calculations were adjusted to take into account any ties in the rankings as done by Ramsey (1989).

## Results

### *I. ricinus* habitat suitability mapping in France

Using two MCDA methods, additive and multiplicative and datasets for two different administrative levels, departmental and municipal, four maps were obtained depicting habitat suitability for *I. ricinus* ticks in France (Figure 3; Figure S1-S3). At the municipal level, some HIS scores could not be calculated due to missing data. For roe deer, data were missing from municipalities in the Haut-Rhin and Bas-Rhin departments in the Northeast, part of the Pyrenees-Orientales department in the South and some municipalities scattered throughout France. No roe deer are present in Corsica. Data on wild boar were not available from municipalities in the Haut-Rhin and Charente Maritime (western coast)

departments and Corsica and some municipalities scattered throughout France. Instead, data at the department level were available for the entire area under study. All maps present variability in HSI scores for *I. ricinus* in France, from low to very high values. With the additive approach, lower HSI scores were obtained in the southern part of the Rhône valley and the highest-elevation areas (Alps and Pyrenees). With the multiplicative approach, more habitat areas with lower suitability were observed, such as Bretagne, Pays de la Loire and part of Nouvelle Aquitaine and Hauts-de-France.

### Comparisons

Using Spearman's rank correlation method, the six abundance indicators were compared to all four sets of HSI scores (additive or multiplicative approach, departmental or municipal level; Table 6). The abundance indicators that demonstrated the best correlation with HSI scores (*i.e.* higher absolute value of rho) were the proportion of observation units with zero nymphs, the median number of nymphs per observation unit, and the average number of nymphs per observation unit. The indicator  $p_{>50}$  showed no significant correlations with HSI scores, but there were only a few observation units in which more than 50 nymphs were collected.

As shown in Table 6, higher correlations were obtained between estimated HSI scores and abundance field data when HSI

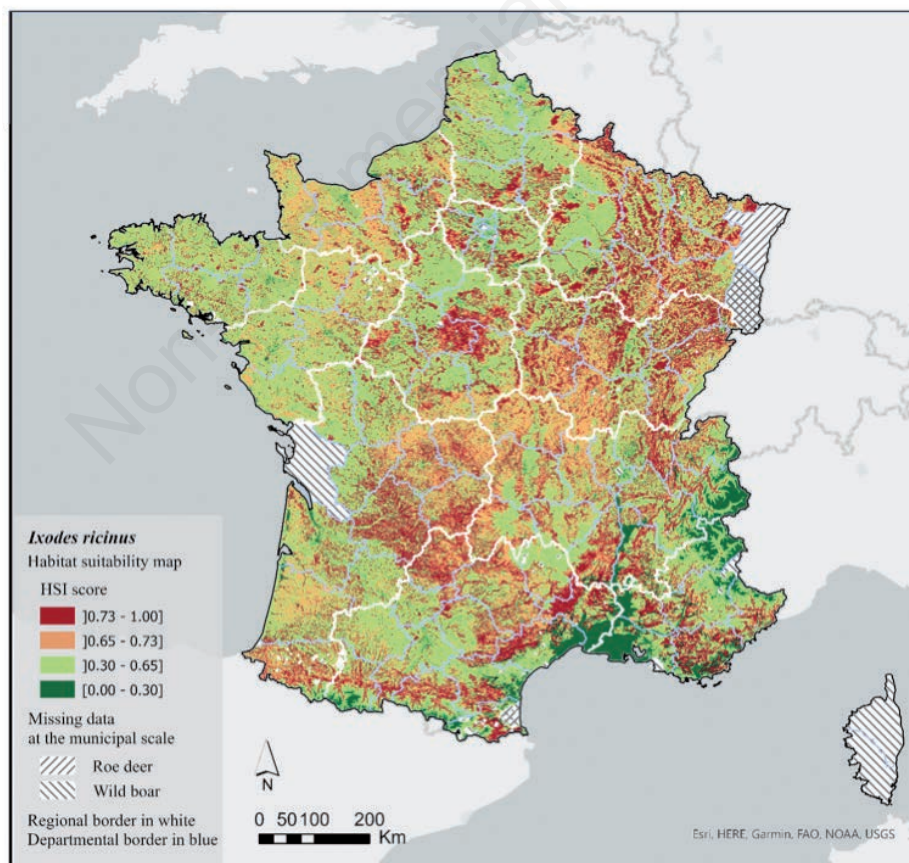

Figure 3. Map of habitat suitability score (HSI) for *I. ricinus* ticks in continental France and Corsica. Results based on the additive approach with municipal-level data for wild boar and roe deer ( $HSI_{mun}^{add}$  see Table 6) Pixel resolution of  $100 \times 100$  m. Threshold values obtained using Jenks natural breaks classification.





scores was calculated at the municipal level rather than the departmental level. At both levels, however, higher correlations were obtained with the additive rather than the multiplicative approach. In the model based on the additive approach with municipal-level ungulate data, significant correlations were confirmed between estimated HSI scores and all abundance indicators except for tick abundance above 50 ticks per 10 m<sup>2</sup>. The best abundance indicators for this model were the median number of collected nymphs (Figure 4) and the proportion of observed units without nymphs (Figure 5). Consequently, we considered this combination - additive approach with ungulate data at the municipal level - to be the best for the habitat suitability map (Figure 3).

Figure 3 shows the presence of highly to very highly suitable habitats for *I. ricinus* (orange and red classes, respectively) in most locations in France, with the exception of the southern part of the Rhône valley and the highest-elevation areas of the Alps and Pyrenees (dark green class). Bretagne, Pays de la Loire and part of the Centre-Val de Loire region are characterised by intermediate suitability (light green class).

### Discussion

The risk for a human or animal to be bitten by a tick is determined by the combination of the presence of ticks (*i.e.* the hazard) and the exposure to tick bites. In this study, we aimed to estimate the hazard component of the overall risk by using a knowledge-based method to produce a habitat suitability map of *I. ricinus* ticks. The resulting map represents the variability in habitat suit-

ability for *I. ricinus* in continental France and Corsica from the least to the most suitable habitat. We used the MCDA method since it was found it an interesting alternative to data-driven statistical methods in cases where detailed field data are not always available. Here, it made it possible to investigate the potential risk of encountering *I. ricinus* throughout continental France and Corsica, even though tick surveillance sampling has only been carried out in relatively few locations. With the MCDA method, we compared two approaches of factor combination, additive and multiplicative, for the generation of an HSI score (Ishizaka and Nemery, 2013). Both approaches have been previously used to map *I. ricinus* habitats (Beugnet *et al.*, 2009; Hönlig *et al.*, 2011; Rousseau *et al.*, 2017; Svec *et al.*, 2019). Recently, Vial *et al.* (2018) used both approaches for *Ornithodoros* ticks and observed similar trends as those reported here. In our study, regardless of the geographic resolution of the dataset (departmental or municipal scale), the correlation between abundance indicators and HSI scores was stronger with the additive approach than with the multiplicative one. Of the two additive models, the HSI scores calculated at the departmental level were always higher than those calculated at the municipal level, an overestimation that was due to the representation and accuracy of the deer and boar data. When calculated at the department scale, abundance data for roe deer and wild boar cannot accurately represent the variability within the departmental territory, while data at the municipal level can.

To validate the HSI scores, we compared these values to nymph abundance data collected primarily in forested sites characterised by highly or very highly suitable habitats for *I. ricinus*. One of the main objectives of our research group is to collect ticks in

**Table 6. Spearman's rank correlation between habitat suitability index scores calculated with the four MCDA models and abundance indicators for nymphs from the 31 sites.**

Nymph abundance indicator	Observation units (no.)	HSI score	rho	P-value	Level of significance
Median number of nymphs	7700	add_mun	0.66	0.000	***
		mx_mun	0.59	0.001	***
		add_dpt	0.56	0.001	***
		mx_dpt	0.54	0.002	**
Mean number of nymphs	7700	add_mun	0.58	0.001	***
		mx_mun	0.56	0.001	***
		add_dpt	0.47	0.005	**
		mx_dpt	0.43	0.011	*
p_zero	2895	add_mun	-0.67	0.000	***
		mx_mun	-0.60	0.000	***
		add_dpt	-0.59	0.001	***
		mx_dpt	-0.56	0.001	***
p_1_10	4210	add_mun	0.46	0.007	**
		mx_mun	0.41	0.016	*
		add_dpt	0.42	0.013	*
		mx_dpt	0.44	0.010	**
p_11_50	575	add_mun	0.45	0.008	**
		mx_mun	0.46	0.007	**
		add_dpt	0.36	0.029	*
		mx_dpt	0.32	0.051	ns
p_>50	20	add_mun	0.16	0.21	ns
		mx_mun	0.13	0.247	ns
		add_dpt	0.08	0.341	ns
		mx_dpt	0.03	0.444	ns

HSI, habitat suitability index; p, proportions of observation units; p\_zero, no nymphs collected; p\_1\_10, 1-10 nymphs collected; p\_11\_50, 11-50 nymphs collected; p\_>50, more than 50 nymphs collected; add, MCDA additive approach; mx, MCDA multiplicative approach; dpt, departmental-level dataset for roe deer and wild boar; mun, municipal-level dataset for roe deer and wild boar; \*\*\*very high significance (P≤0.001); \*\*high significance (P≤0.01); \*clear significance (P≤0.05); ns, not significant (P>0.05).

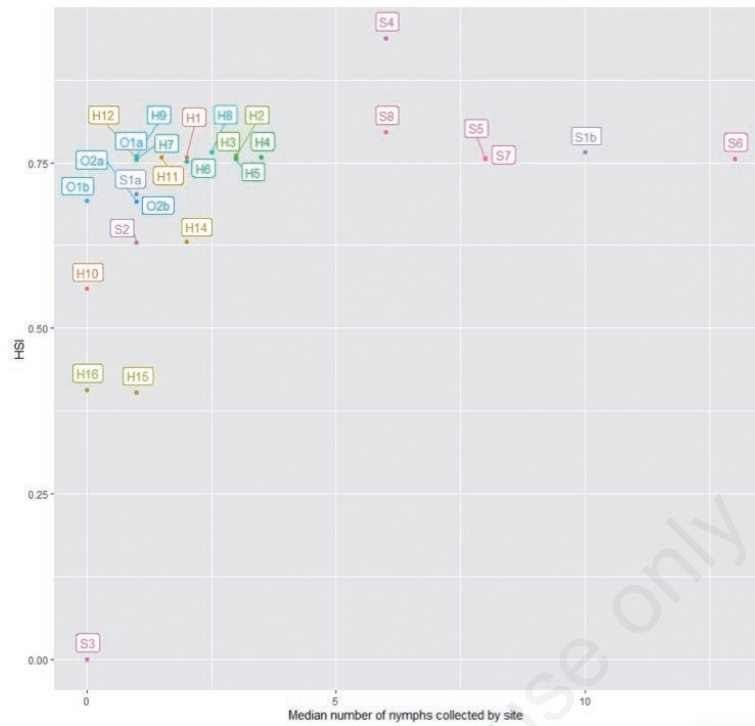

Figure 4. Correlation between median habitat suitability index (HSI) scores and the median number of nymphs collected per observation unit for each site. The HSI scores were calculated with the additive approach and municipal-level ungulate data ( $HSI_{mun}^{add}$ ). For names of the collection sites see Table 5.

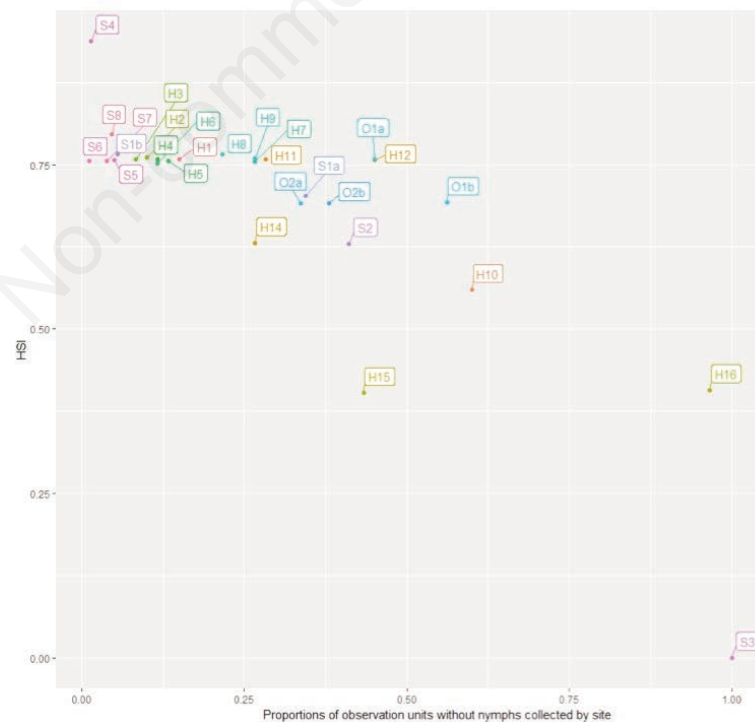

Figure 5. Correlation between median habitat suitability index (HSI) scores and the proportion of observation units with zero nymph collected per site ( $p_{zero}$ ). The HSI scores were calculated with the additive approach and municipal-level ungulate data ( $HSI_{mun}^{add}$ ). For names of the collection sites see Table 5.



order to estimate the prevalence of *Borrelia* infection in the ticks. Forest sites are preferentially chosen for this work because the density of *I. ricinus* ticks is generally higher, whether in rural (Boyard *et al.*, 2011; Asghar *et al.*, 2016) or urban areas (Paul *et al.*, 2016b; Mathews-Martin *et al.*, 2020). In this study, only three of the forested sites used for validation were determined to be less suitable because they were located in the Mediterranean South climate zone or were at a high altitude. Future field studies with a larger set of observations would be invaluable for further validation of the habitat suitability map. In particular, future sampling campaigns should focus on areas with low and medium HSI values to assess and confirm the limits of the tick's distribution. Until this can be accomplished, it is important to interpret the global habitat suitability maps with caution, in particular for areas of low suitability. These putative low-abundance areas should be further monitored, with the needs of different stakeholders in mind. Overall though, the relevance of the HSI score as an indicator of low tick risk was validated by our analysis of the correlation with field data. In particular, a strong negative correlation was observed between HSI scores and the proportion of observation units in which no ticks were sampled. That is, the higher the HSI score, the smaller the proportion of observation units where no ticks were sampled, and conversely, the smaller the HSI score, the higher the proportion of observation units where no ticks were sampled. Given this finding, low HSI scores could be used as an indicator of lower abundance in any areas not yet studied.

Although we were able to increase the accuracy of HSI scores by using data from the municipal rather than the departmental level, there are ways to refine the analysis potentially further. For example, it might be possible to improve HSI scores by calculating weights for each factor using the analytical hierarchy process (Estoque, 2012; Paul *et al.*, 2016a). It might also help to attribute more nuanced index values to the HSI for climate, or to consider other factors that contribute to *I. ricinus* habitat suitability. Indeed, the population densities of rodents and birds play a well-recognized role in the life cycle of ticks and as reservoirs of *B. burgdorferi* s.l. (Perez *et al.*, 2016; Klitgaard *et al.*, 2019; Martello *et al.*, 2019). These factors were not included in the current analysis because of the lack of reliable data at the departmental and municipal levels, but also because they are highly variable among local areas of tick habitat due to changes in rodent and bird populations, weather, food availability and leaf litter (Beugnet *et al.*, 2009; Medlock *et al.*, 2013; Vourc'h *et al.*, 2016; Goldstein *et al.*, 2018). Such small-scale changes can have strong consequences for local tick abundance (Boyard *et al.*, 2008).

The habitat suitability map that was calculated with municipal-scale data for wild boar and roe deer showed that conditions were favourable for tick development over most of France: a higher degree of hazard was estimated for central, north-eastern, and south-western France, and a lower degree of hazard in Mediterranean and mountainous regions. The map generated here was largely consistent with previously published maps of Europe based on models or field observations (Beugnet *et al.*, 2009; Estrada-Peña *et al.*, 2013; Estrada-Peña *et al.*, 2016; ECDC, 2019; Li *et al.*, 2019) and in many locations our map delivered more-accurate results. For example, the ECDC tick map of Europe, which examined France at the departmental scale, indicate that *I. ricinus* is present throughout France (ECDC, 2019) even though it is known to be largely absent in the Mediterranean area. Other prior maps indicate that *I. ricinus* is absent from Bretagne and Hauts-de-France (Li *et al.*, 2019) or Occitania (Estrada-Peña *et al.*,

2016), which are all regions in which this species has been observed. Our map provides indications on the suitability of local habitats for *I. ricinus* but does not account for seasonal variations in tick activity (Perez *et al.*, 2012; Wongnak *et al.*, 2022b). The information contained in the map could help in the management of prevention methods and public health messaging, in particular in identifying regions where public awareness campaigns aimed at prevention should be given priority. To limit the risk of pathogen transmission, it is crucial to reduce human exposure to ticks through a variety of preventive measures, including the publication of recommendations regarding tick bites. To improve the efficacy of such campaigns, efforts should also be made to improve knowledge and human comprehension of the risk (Aenishaenslin *et al.*, 2015; Bord *et al.*, 2022).

Previous studies have shown that tick control can be performed by agencies tasked with forest or landscape management, care of urban greenspaces, control of invasive species, or wild animal management (Stafford, 2004; Gilbert *et al.*, 2012; Millins *et al.*, 2017; Tsao *et al.*, 2021). On an individual level, each person can manage his or her own efforts to prevent tick bites, but this kind of behaviour is non-standard and not systematically adopted across a population (Hook *et al.*, 2015; Butler *et al.*, 2016; Aenishaenslin *et al.*, 2017) because people do not know where and when ticks are present. Maps such as ours could be a straightforward way to help non-tick-specialists identify the risk. The maps could also help primary health care providers such as retail pharmacists to raise awareness of the tick risk. Indeed, pharmacists are frequently the first source of medical information in the event of a tick bite; a survey in the Auvergne-Rhône-Alpes region has shown that pharmacists have solid knowledge about preventive measures for tick bites and Lyme disease, but weaker knowledge about tick biology, *e.g.*, hosts, suitable habitats, favourable conditions for tick activity (Bord *et al.*, 2022). Furthermore, this map could serve as a tool for the French Health Ministry's efforts to implement a national plan for the control of Lyme disease and other tick-borne diseases (Ministère des Solidarités et de la Santé, 2016). In the future, it can be adjusted to account for different scenarios, such as global warming and the evolution of animal populations. Indeed, the strength of our approach is that it is easily adapted to support changing discourse on tick-bite prevention depending on specific conditions (environment, season, setting, human activities related to this problem) and can be used as an effective communication tool for alerting citizens facing a potential hazard. This is all the more important because the hazard represented by *I. ricinus* varies according to the season (Vollack *et al.*, 2017), climatic factors (Alkishe *et al.*, 2017; Boehnke *et al.*, 2017; Cayol *et al.*, 2017; Furness and Furness, 2018) and the presence of hosts (Qviller *et al.*, 2016).

The maps generated in this study represent the presence of the hazard and can be used, through combination with maps of the presence of human populations, to estimate the overall risks posed by ticks. Humans can be exposed to tick bites during high-risk outdoor professional activities - *e.g.*, foresters, veterinarians, and farmers (Thorin *et al.*, 2008; De Keukeleire *et al.*, 2016; Wierzbicka *et al.*, 2016) - through leisure activities, or simply because they live in an environment that supports a large population of ticks. People participating in recreational activities have been bitten by ticks in forests, parks and gardens, even in urban and suburban areas (Rizzoli *et al.*, 2014; De Keukeleire *et al.*, 2015; Hall *et al.*, 2017). The Citique project (<https://www.citique.fr/>), which logged information on tick bites



based on citizen participation, showed that the distribution of tick bites was very uneven throughout France as a whole. Such data could be used in the future to validate maps of tick bite risk.

## Conclusions

This study provides further evidence of the usefulness of the MCDA method for estimating habitat suitability maps for *I. ricinus*. MCDA is a low-cost approach and does not require extensive data from field surveys, relying instead on existing proxy data and knowledge. Here it was applied at departmental and municipal levels at a national scale, but the same method could be used to produce maps for smaller geographical areas, e.g., urban and peri-urban areas and national parks. A similar approach could also be used to model the distribution of other tick species of medical importance (including *Dermacentor*, *Rhipicephalus* and *Hyalomma*) and possible future local extinctions or expansions that occur as a result of global climate change. Indeed, in the context of accelerating global change and possible introductions of new species, efforts should be made to implement and support surveillance networks and tools with the aim of increasing and improving knowledge on the distribution of ticks and tick-borne pathogens in France.

## References

- Aenishaenslin C, Bouchard C, Koffi JK, Ogden NH, 2017. Exposure and preventive behaviours toward ticks and Lyme disease in Canada: Results from a first national survey. *Ticks Tick-Borne Dis* 8:112-8.
- Aenishaenslin C, Gern L, Michel P, Ravel A, Hongoh V, Waub JP, Milord F, Belanger D, 2015. Adaptation and evaluation of a multi-criteria decision analysis model for Lyme disease prevention. *PLoS One* 10:e0135171.
- Agoulon A, Butet A, Hoch T, Perez G, Plantard O, Verheyden H, Vourc'h G, 2016. 3. Dynamique des populations de tiques et liaison avec les facteurs environnementaux. In: Karen DM, Nathalie B (Eds.), *Tiques et maladies à tiques : biologie, écologie évolutive, épidémiologie*. IRD Editions, Marseille, France, pp. 85-112.
- Akl T, Bourgoin G, Souq M-L, Appolinaire J, Poirel M-T, Gibert P, Abi Rizk G, Garel M, Zenner L, 2019. Detection of tick-borne pathogens in questing *Ixodes ricinus* in the French Pyrenees and first identification of *Rickettsia monacensis* in France. *Parasite* 26:20.
- Alfredsson M, Olafsson E, Eydal M, Unnsteinsdottir ER, Hansford K, Wint W, Alexander N, Medlock JM, 2017. Surveillance of *Ixodes ricinus* ticks (Acari: Ixodidae) in Iceland. *Parasites Vectors* 10:466.
- Asghar N, Petersson M, Johansson M, Dinnetz P, 2016. Local landscape effects on population dynamics of *Ixodes ricinus*. *Geospat Health* 11:487.
- Aubry P, Guillemain M, 2019. Attenuating the nonresponse bias in hunting bag surveys: The multiphase sampling strategy. *PLoS One* 14:e0213670.
- Beugnet F, Chalvet-Monfray K, Loukos H, 2009. FleaTickRisk: a meteorological model developed to monitor and predict the activity and density of three tick species and the cat flea in Europe. *Geospat Health* 4:97-113.
- Boehnke D, Brugger K, Pfaffle M, Sebastian P, Norra S, Petney T, Oehme R, Littwin N, Lebl K, Raith J, Walter M, Gebhardt R, Rubel F, 2015. Estimating *Ixodes ricinus* densities on the landscape scale. *Int J Health Geogr* 14:23.
- Bonnet S, Huber K, Joncour G, René-Martellet M, Stachurski F, Zenner L, 2016. 2. Biologie des tiques. In: Karen DM, Nathalie B (Eds.), *Tiques et maladies à tiques - Biologie, écologie évolutive, épidémiologie*. IRD Editions, Marseille, France, pp. 53-84.
- Bord S, Dernat S, Ouillon L, René-Martellet M, Vourc'h G, Lesens O, Forestier C, Lebert I, 2022. Tick ecology and Lyme borreliosis prevention: a regional survey of pharmacists' knowledge in Auvergne-Rhône-Alpes, France. *Ticks Tick-Borne Dis* 13:101932.
- Bord S, Lebert I, René-Martellet M, Dernat S, Johany F, Bimonte S, Chalvet-Monfray K, Poux V, Cosson JF, Smoreda Z, Vourc'h G, 2019. Intérêt des données de téléphonie mobile et des sciences participatives pour l'estimation et la compréhension du risque de transmission de maladies liées à l'environnement: Application aux maladies transmises par les tiques. In *Réunion Tiques & Maladies à Tiques - 22-23 may 2019*, Montpellier, France.
- Boyard C, Barnouin J, Bord S, Gasqui P, Vourc'h G, 2011. Reproducibility of local environmental factors for the abundance of questing *Ixodes ricinus* nymphs on pastures. *Ticks Tick-Borne Dis* 2:104-110.
- Boyard C, Vourc'h G, Barnouin J, 2008. The relationships between *Ixodes ricinus* and small mammal species at the woodland-pasture interface. *Exp Appl Acarol* 44:61-76.
- Brugger K, Boehnke D, Petney T, Dobler G, Pfeffer M, Silaghi C, Schaub GA, Pinior B, Dautel H, Kahl O, Pfister K, Suss J, Rubel F, 2016. A density map of the tick-borne encephalitis and Lyme borreliosis vector *Ixodes ricinus* (Acari: Ixodidae) for Germany. *J Med Entomol* 53:1292-302.
- Butler AD, Sedghi T, Petrini JR, Ahmadi R, 2016. Tick-borne disease preventive practices and perceptions in an endemic area. *Ticks Tick-Borne Dis* 7:331-7.
- Cadenas FM, Rais O, Jouda F, Douet V, Humair P-F, Moret J, Gern L, 2007. Phenology of *Ixodes ricinus* and infection with *Borrelia burgdorferi* sensu lato along a North- and South-facing altitudinal gradient on Chaumont Mountain, Switzerland. *J Med Entomol* 44:683-93.
- Cat J, Beugnet F, Hoch T, Jongejan F, Prange A, Chalvet-Monfray K, 2017. Influence of the spatial heterogeneity in tick abundance in the modeling of the seasonal activity of *Ixodes ricinus* nymphs in Western Europe. *Exp Appl Acarol* 71:115-30.
- Chen D, Wong H, Belanger P, Moore K, Peterson M, Cunningham J, 2015. Analyzing the correlation between deer habitat and the component of the risk for Lyme disease in Eastern Ontario, Canada: A GIS-based approach. *ISPRS Int J Geoinf* 4:105-23.
- Daniel M, Danielova V, Kriz B, Jirsa A, Nozicka J, 2003. Shift of the tick *Ixodes ricinus* and tick-borne encephalitis to higher altitudes in Central Europe. *Eur J Clin Microbiol Infect Dis* 22:327-8.
- Daniel M, Danielova V, Kriz B, Ruzek D, Fialova A, Maly M, Materna J, Pejcoch M, Erhart J, 2016a. The occurrence of *Ixodes ricinus* ticks and important tick-borne pathogens in areas with high tick-borne encephalitis prevalence in different altitudinal levels of the Czech Republic Part I. *Ixodes ricinus* ticks and tick-borne encephalitis virus. *Epidemiol Mikrobiol*



- Imunol 65:118-28.
- Daniel M, Rudenko N, Golovchenko M, Danielova V, Fialova A, Kriz B, Maly M, 2016b. The occurrence of *Ixodes ricinus* ticks and important tick-borne pathogens in areas with high tick-borne encephalitis prevalence in different altitudinal levels of the Czech Republic Part II. *Ixodes ricinus* ticks and genospecies of *Borrelia burgdorferi* sensu lato complex. *Epidemiol Mikrobiol Imunol* 65:182-92.
- Danielova V, Daniel M, Schwarzova L, Materna J, Rudenko N, Golovchenko M, Holubova J, Grubhoffer L, Kilian P, 2010. Integration of a tick-borne encephalitis virus and *Borrelia burgdorferi* sensu lato into mountain ecosystems, following a shift in the altitudinal limit of distribution of their vector, *Ixodes ricinus* (Krkonoše mountains, Czech Republic). *Vector Borne Zoonotic Dis* 10:223-30.
- De Keukeleire M, Robert A, Kabamba B, Dion E, Luyasu V, Vanwambeke SO, 2016. Individual and environmental factors associated with the seroprevalence of *Borrelia burgdorferi* in Belgian farmers and veterinarians. *Infect Ecol Epidemiol* 16:32793.
- De Keukeleire M, Vanwambeke SO, Somasse E, Kabamba B, Luyasu V, Robert A, 2015. Scouts, forests, and ticks: Impact of landscapes on human-tick contacts. *Ticks Tick-Borne Dis* 6:636-44.
- De Pelsmaecker N, Korslund L, Steifetten Ø, 2021. High-elevation occurrence of two tick species, *Ixodes ricinus* and *I. trianguliceps*, at their northern distribution range. *Parasites Vectors* 14:161.
- Derringer R, Suich R, 1980. Simultaneous optimization of several response variables. *J Qual Technol* 12:214-9.
- ECDC, 2019. A spatial modelling method for vector surveillance. European Centre for Disease Prevention and Control, Stockholm, 29 pp.
- Estoque RC, 2012. Chapter 11: Analytic hierarchy process in geospatial analysis, In: Murayama Y (Ed.) *Progress in Geospatial Analysis*. Springer, Japan, pp. 157-181.
- Estoque RC, Murayama Y, 2010. Suitability analysis for beekeeping sites in La Union, Philippines, using GIS and multi-criteria evaluation techniques. *Res J Appl Sci* 5:242-53.
- Estrada-Peña A, Alexander N, Wint GRW, 2016. Perspectives on modelling the distribution of ticks for large areas: so far so good? *Parasites Vectors* 9:179.
- Estrada-Peña A, Farkas R, Jaenson TG, Koenen F, Madder M, Pascucci I, Salman M, Tarres-Call J, Jongejan F, 2013. Association of environmental traits with the geographic ranges of ticks (Acari: Ixodidae) of medical and veterinary importance in the western Palearctic. A digital data set. *Exp Appl Acaro* 159:351-66.
- Estrada-Peña A, Venzal JM, 2007. Climate niches of tick species in the Mediterranean region: Modeling of occurrence data, distributional constraints, and impact of climate change. *J Med Entomol* 44:1130-8.
- Estrada-Peña A, Venzal JM, Sanchez Acedo C, 2006. The tick *Ixodes ricinus*: distribution and climate preferences in the western Palaearctic. *Med Vet Entomol* 20:189-97.
- Fabri ND, Sprong H, Hofmeester TR, Heesterbeek H, Donnars BF, Widemo F, Ecke F, Cromsigt JPM, 2021. Wild ungulate species differ in their contribution to the transmission of *Ixodes ricinus*-borne pathogens. *Parasites Vectors* 14:360.
- Gilbert L, Maffey G, Ramsay S, Hester A, 2012. The effect of deer management on the abundance of *Ixodes ricinus* in Scotland. *Ecol Appl* 22:658-67.
- Gilot C, Deleign B, Pichot J, Doche B, Guigen C, 1996. Prevalence of *Borrelia burgdorferi* (sensu lato) in *Ixodes ricinus* (L.) populations in France, according to a phytoecological zoning of the territory. *Eur J Epidemiol* 12:395-401.
- Goldstein V, Boulanger N, Schwartz D, George J-C, Ertlen D, Zilliox L, Schaeffer M, Jaulhac B, 2018. Factors responsible for *Ixodes ricinus* nymph abundance: Are soil features indicators of tick abundance in a French region where Lyme borreliosis is endemic? *Ticks Tick-Borne Dis* 9:938-44.
- Hall JL, Alpers K, Bown KJ, Martin SJ, Birtles RJ, 2017. Use of mass-participation outdoor events to assess human exposure to tickborne pathogens. *Emerg Infect Dis* 23:463-7.
- Hansford KM, Fonville M, Gillingham EL, Coipan EC, Pietzsch ME, Krawczyk AI, Vaux AGC, Cull B, Sprong H, Medlock JM, 2017. Ticks and *Borrelia* in urban and peri-urban green space habitats in a city in southern England. *Ticks Tick-Borne Dis* 8:353-61.
- Hofmeester TR, Sprong H, Jansen PA, Prins HHT, van Wieren SE, 2017. Deer presence rather than abundance determines the population density of the sheep tick, *Ixodes ricinus*, in Dutch forests. *Parasites Vectors* 10:433.
- Hongoh V, Hoen AG, Aenishaenslin C, Waaub JP, Belanger D, Michel P, Lyme MC, 2011. Spatially explicit multi-criteria decision analysis for managing vector-borne diseases. *Int J Health Geogr* 10:70.
- Hönig V, Švec P, Marek L, Mrkvička T, Dana Z, Wittmann M, Masař O, Szturcová D, Růžek D, Pfister K, Grubhoffer L, 2019. Model of risk of exposure to Lyme borreliosis and tick-borne encephalitis virus-infected ticks in the border area of the Czech Republic (South Bohemia) and Germany (Lower Bavaria and Upper Palatinate). *Int J Environ Res Public Health* 16:1173.
- Hönig V, Švec P, Masař O, Gribhoffer L, 2011. Tick-borne diseases risk model for south Bohemia (Czech Republic). *GIS Ostrava* 23-26.
- Hook SA, Nelson CA, Mead PS, 2015. U.S. public's experience with ticks and tick-borne diseases: results from national health styles surveys. *Ticks Tick-Borne Dis* 6: 483-8.
- Ishizaka A, Nemery P, 2013. Multi-criteria decision analysis: methods and software. Wiley, UK, 310 pp.
- Joly D, Brossard T, Cardot H, Cavailles J, Hilal M, Wavresky P, 2010. Les types de climats en France, une construction spatiale Cybergeog. *Eur J Geogr* 501:1-26.
- Klitgaard K, Højgaard J, Isbrand A, Madsen JJ, Thorup K, Bødker R, 2019. Screening for multiple tick-borne pathogens in *Ixodes ricinus* ticks from birds in Denmark during spring and autumn migration seasons. *Ticks Tick-Borne Dis* 10: 546-52.
- Lebert I, Agoulon A, Bastian S, Butet A, Cargnelutti B, Cèbe N, Chastagner A, Léger E, Lourtet B, Maseglia S, McCoy KD, Merlet J, Noël V, Perez G, Picot D, Pion A, Poux V, Rames J-L, Rantier Y, Verheyden H, Vourc'h G, Plantard O, 2020. Distribution of ticks, tick-borne pathogens and the associated local environmental factors including small mammals and livestock, in two French agricultural sites: the OSCAR database. *Biodivers Data J* 8:e50123.
- Lees AD, 1946. The water balance in *Ixodes ricinus* L. and certain otherspecies of ticks. *Parasitology* 37:1-20.
- Lejal E, Marsot M, Chalvet-Monfray K, Cosson J-F, Moutailler S, Vayssier-Taussat M, Pollet T, 2019. A three-years assessment of *Ixodes ricinus*-borne pathogens in a French peri-urban for-

- est. *Parasites Vectors* 12:551.
- Li S, Gilbert L, Vanwambeke SO, Yu J, Purse BV, Harrison PA, 2019. Lyme disease risks in Europe under multiple uncertain drivers of change. *Environ Health Perspect* 127:067010.
- Maetzel D, Maier WA, Kampen H, 2005. *Borrelia burgdorferi* infection prevalences in questing *Ixodes ricinus* ticks (Acari: Ixodidae) in urban and suburban Bonn, western Germany. *Parasitol Res* 95:5-12.
- Malczewski J, 2000. On the use of weighted linear combination method in GIS: common and best practice approaches. *Trans GIS* 4:5-22.
- Martello E, Mannelli A, Grego E, Ceballos LA, Ragagli C, Stella MC, Tomassone L, 2019. *Borrelia burgdorferi* sensu lato and spotted fever group rickettsiae in small rodents and attached ticks in the Northern Apennines, Italy. *Ticks Tick-Borne Dis* 10:862-7.
- Materna J, Daniel M, Metelka L, Harcarika J, 2008. The vertical distribution, density and the development of the tick *Ixodes ricinus* in mountain areas influenced by climate changes (The Krkonose Mts., Czech Republic). *Int J Med Microbiol* 298:25-37.
- Mathews-Martin L, Namèche M, Vourc'h G, Gasser S, Lebert I, Poux V, Barry S, Bord S, Jachacz J, Chalvet Monfray K, Bourdoiseau G, Sepúlveda D, Chambon-Rouvier S, René-Martellet M, 2020. Questing tick abundance in urban and peri-urban parks in the French city of Lyon. *Parasites Vectors* 13:576.
- Medlock JM, Hansford KM, Bormane A, Derdakova M, Estrada-Pena A, George JC, Golovljova I, Jaenson TG, Jensen JK, Jensen PM, Kazimirova M, Oteo JA, Papa A, Pfister K, Plantard O, Randolph SE, Rizzoli A, Santos-Silva MM, Sprong H, Vial L, Hendrickx G, Zeller H, Van Bortel W, 2013. Driving forces for changes in geographical distribution of *Ixodes ricinus* ticks in Europe. *Parasites Vectors* 6:1.
- Metzger MJ, Bunce RGH, Jongman RHG, Múcher CA, Watkins JW, 2005. A climatic stratification of the environment of Europe. *Glob Ecol Biogeogr* 14:549-63.
- Millins C, Gilbert L, Medlock J, Hansford K, Thompson DB, Biek R, 2017. Effects of conservation management of landscapes and vertebrate communities on Lyme borreliosis risk in the United Kingdom. *Philos Trans R Soc Lond B Biol Sci* 372.
- Ministère des Solidarités et de la Santé, 2016. Plan national de lutte contre la maladie de Lyme et les maladies transmissibles par les tiques. Available from: [https://solidarites-sante.gouv.fr/IMG/pdf/plan\\_lyme\\_180117.pdf](https://solidarites-sante.gouv.fr/IMG/pdf/plan_lyme_180117.pdf)
- Múcher CA, Klijn JA, Wascher DM, Schaminée JHJ, 2010. A new European landscape classification (LANMAP): a transparent, flexible and user-oriented methodology to distinguish landscapes. *Ecol Indic* 10:87-103.
- Mysterud A, Hügli C, Viljugrein H, 2021. Tick infestation on medium-large-sized mammalian hosts: are all equally suitable to *Ixodes ricinus* adults? *Parasites Vectors* 14:254.
- Paul MC, Goutard FL, Roulleau F, Holl D, Thanapongtharm W, Roger FL, Tran A, 2016a. Quantitative assessment of a spatial multicriteria model for highly pathogenic avian influenza H5N1 in Thailand, and application in Cambodia. *Sci Rep* 6:31096.
- Paul RE, Cote M, Le Naour E, Bonnet SI, 2016b. Environmental factors influencing tick densities over seven years in a French suburban forest. *Parasites Vectors* 9:309.
- Perez D, Kneubuhler Y, Rais O, Gern L, 2012. Seasonality of *Ixodes ricinus* ticks on vegetation and on rodents and *Borrelia burgdorferi* sensu lato genospecies diversity in two Lyme borreliosis-endemic areas in Switzerland. *Vector Borne Zoonotic Dis* 12:633-44.
- Perez G, Bastian S, Agoulon A, Bouju A, Durand A, Faille F, Lebert I, Rantier Y, Plantard O, Butet A, 2016. Effect of landscape features on the relationship between *Ixodes ricinus* ticks and their small mammal hosts. *Parasites Vectors* 9:20.
- Pfeiffer DU, Robinson TP, Stevenson M, Stevens KB, Rogers DJ, Clements ACA, 2008. *Spatial analysis in epidemiology*. Oxford University Press, New York, NY, USA, 160 pp.
- R Core Team 2017. R: A language and environment for statistical computing, R Foundation for Statistical Computing, ed. Vienna, Austria. Available from: <https://www.R-project.org/>
- Radolf J, Caimano M, Stevenson B, Hu L, 2012. Of ticks, mice and men: understanding the dual-host lifestyle of Lyme disease spirochaetes. *Nat Rev Microbiol* 10:87-99.
- Ragagli C, Mannelli A, Ambrogi C, Bisanzio D, Ceballos LA, Grego E, Martello E, Selmi M, Tomassone L, 2016. Presence of host-seeking *Ixodes ricinus* and their infection with *Borrelia burgdorferi* sensu lato in the Northern Apennines, Italy. *Exp Appl Acarol* 69:167-78.
- Ramsey PH, 1989. Critical values for Spearman's rank order correlation. *J Educ Stat* 14:245-53.
- Réseau sentinelles, 2021. Bilan annuel d'activités 2020, Janvier à décembre 2020, Veille sanitaire et recherche en soins primaires, Inserm, Médecine Sorbonne Université. Available from: <https://www.sentiweb.fr/document/5361>
- Rizzoli A, Silaghi C, Obiegala A, Rudolf I, Hubalek Z, Foldvari G, Plantard O, Vayssier-Taussat M, Bonnet S, Spitalska E, Kazimirova M, 2014. *Ixodes ricinus* and its transmitted pathogens in urban and peri-urban areas in Europe: new hazards and relevance for public health. *Front Public Health* 2:251.
- Rousseau R, McGrath G, McMahon BJ, Vanwambeke SO, 2017. Multi-criteria decision analysis to model *Ixodes ricinus* habitat suitability. *Ecohealth* 14:591-602.
- Saint-Andrieux C, Barboiron A, 2014. Tableaux de chasse ongulés sauvages saison 2013-2014. *Faune Sauvage Suppl*:I-VIII.
- Sandor AD, D'Amico G, Gherman CM, Dumitrache MO, Domsa C, Mihalca AD, 2017. Mesocarnivores and macroparasites: altitude and land use predict the ticks occurring on red foxes (*Vulpes vulpes*). *Parasites Vectors* 10:173.
- Semenza J, Suk J, 2018. Vector-borne diseases and climate change: a European perspective. *FEMS Microbiol Lett* 365.
- Stafford KC, 2004. *Tick management handbook; an integrated guide for homeowners, pest control operators, and public health officials for the prevention of tick-associated disease*. Connecticut Agricultural Experiment Station, 71 pp.
- Svec P, Honig V, Zubrikova D, Wittmann M, Pfister K, Grubhoffer L, 2019. The use of multi-criteria evaluation for the selection of study plots for monitoring of *I. ricinus* ticks - Example from Central Europe. *Ticks Tick-Borne Dis* 10:905-10.
- Swart A, Ibanez-Justicia A, Buijs J, van Wieren SE, Hofmeester TR, Sprong H, Takumi K, 2014. Predicting tick presence by environmental risk mapping. *Front Public Health* 2:238.
- Tack W, Madder M, Baeten L, Vanhellefont M, Gruwez R, Verheyen K, 2012. Local habitat and landscape affect *Ixodes ricinus* tick abundances in forests on poor, sandy soils. *For Ecol Manag* 265:30-6.
- Taragel'ova VR, Mahrikova L, Selyemova D, Vaclav R,





- Derdakova M, 2016. Natural foci of *Borrelia lusitaniae* in a mountain region of Central Europe. *Ticks Tick-Borne Dis* 7:350-6.
- Thorin C, Rigaud E, Capek I, Andre-Fontaine G, Oster B, Gastinger G, Abadia G, 2008. Seroprevalence of Lyme borreliosis and tick-borne encephalitis in workers at risk, in eastern France. *Med Mal Infect* 38:533-42.
- Tsao JI, Hamer SA, Han S, Sidge JL, Hickling GJ, 2021. The contribution of wildlife hosts to the rise of ticks and tick-borne diseases in North America. *J Med Entomol* 58:1565-87.
- Uusitalo R, Siljander M, Dub T, Sane J, Sormunen JJ, Pellikka P, Vapalahti O, 2020. Modelling habitat suitability for occurrence of human tick-borne encephalitis (TBE) cases in Finland. *Ticks Tick-Borne Dis* 11:101457.
- Vanwambeke SO, Van Doninck J, Artois J, Davidson RK, Meyfroidt P, Jore S, 2016. Forest classes and tree cover gradient: tick habitat in encroached areas of southern Norway. *Exp Appl Acarol* 68:375-85.
- Vassallo M, Pichon B, Cabaret J, Figureau C, Pérez-Eid C, 2000. Methodology for sampling questing nymphs of *Ixodes Ricinus* (Acari: Ixodidae), the principal vector of Lyme disease in Europe. *J Med Entomol* 37:335-339.
- Vial L, Ducheyne E, Filatov S, Gerilovych A, McVey DS, Sindryakova I, Morgunov S, Pérez de León AA, Kolbasov D, De Clercq EM, 2018. Spatial multi-criteria decision analysis for modelling suitable habitats of *Ornithodoros* soft ticks in the Western Palearctic region. *Vet Parasitol* 249:2-16.
- Vourc'h G, Abrial A, Bord S, Jacquot M, Masségli S, Poux V, Pisanu B, Bailly X, Chapuis JL, 2016. Mapping human risk of infection with *Borrelia burgdorferi sensu lato*, the agent of Lyme borreliosis, in a periurban forest in France. *Ticks Tick-Borne Dis* 7:644-52.
- Wierzbicka A, Raczka G, Skorupski M, Michalik J, Lane RS, 2016. Human behaviors elevating the risk of exposure to *Ixodes ricinus* larvae and nymphs in two types of lowland coniferous forests in west-central Poland. *Ticks Tick-Borne Dis* 7:1180-5.
- Wongnak P, Bord S, Donnet S, Hoch T, Beugnet F, Chalvet-Monfray K, 2022a. A hierarchical Bayesian approach for incorporating expert opinions into parametric survival models: A case study of female *Ixodes ricinus* ticks exposed to various temperature and relative humidity conditions. *Ecol Model* 464:109821.
- Wongnak P, Jacquot M, Bord S, Agoulon A, Beugnet F, Bournez L, Cèbe N, Chevalier A, Cosson J-F, Dambrine N, Hoch T, Huard F, Huber K, Korboulewsky N, Lebert I, Madouasse A, Marell A, Moutailler S, Plantard O, Pollet T, Poux V, René-Martellet M, Stachurski F, Vayssier-Taussat M, Verheyden H, Vial L, Vourc'h G, Chalvet-Monfray K 2022. Dataset of *Ixodes ricinus* ticks in mainland France (CLIMATICK and CC-EID projects), Chalvet-Monfray K, ed. Portail Data INRAE 2022. doi:10.15454/ZSYGUM
- Wongnak P, Bord S, Jacquot M, Agoulon A, Beugnet F, Bournez L, Cèbe N, Chevalier A, Cosson JF, Dambrine N, Hoch T, Huard F, Korboulewsky N, Lebert I, Madouasse A, Mârell A, Moutailler S, Plantard O, Pollet T, Poux V, René-Martellet M, Vayssier-Taussat M, Verheyden H, Vourc'h G, Chalvet-Monfray K, 2022. Meteorological and climatic variables predict the phenology of *Ixodes ricinus* nymph activity in France, accounting for habitat heterogeneity. *Sci Rep* 12:7833. doi:10.1038/s41598-022-11479-z.
- Zeimes CB, Olsson GE, Hjertqvist M, Vanwambeke SO, 2014. Shaping zoonosis risk: landscape ecology vs. landscape attractiveness for people, the case of tick-borne encephalitis in Sweden. *Parasites Vectors* 7:370.
- Zubriková D, Wittmann M, Hönig V, Švec P, Vichová B, Essbauer S, Dobler G, Grubhoffer L, Pfister K, 2020. Prevalence of tick-borne encephalitis virus and *Borrelia burgdorferi sensu lato* in *Ixodes ricinus* ticks in Lower Bavaria and Upper Palatinate, Germany. *Ticks Tick-Borne Dis* 11:101375.