



**HAL**  
open science

# Hormonal control of cell identity and growth in the shoot apical meristem

Bihai Shi, Teva Vernoux

► **To cite this version:**

Bihai Shi, Teva Vernoux. Hormonal control of cell identity and growth in the shoot apical meristem. Current Opinion in Plant Biology, 2022, 65, pp.102111. 10.1016/j.pbi.2021.102111 . hal-03772938

**HAL Id: hal-03772938**

**<https://hal.inrae.fr/hal-03772938>**

Submitted on 22 Nov 2022

**HAL** is a multi-disciplinary open access archive for the deposit and dissemination of scientific research documents, whether they are published or not. The documents may come from teaching and research institutions in France or abroad, or from public or private research centers.

L'archive ouverte pluridisciplinaire **HAL**, est destinée au dépôt et à la diffusion de documents scientifiques de niveau recherche, publiés ou non, émanant des établissements d'enseignement et de recherche français ou étrangers, des laboratoires publics ou privés.



Distributed under a Creative Commons Attribution - NonCommercial - NoDerivatives 4.0 International License

## Hormonal control of cell identity and growth in the shoot apical meristem

Bihai Shi<sup>1,2,3</sup>, Teva Vernoux<sup>3</sup>

<sup>1</sup> College of Agriculture, South China Agricultural University, 510642, Guangzhou, China

<sup>2</sup> Guangdong Laboratory for Lingnan Modern Agriculture, 510642, Guangzhou, China

<sup>3</sup> Laboratoire Reproduction et Développement des Plantes, Univ Lyon, ENS de Lyon, CNRS, INRAE, F-69342, Lyon, France

Corresponding author: Vernoux, Teva ([teva.vernoux@ens-lyon.fr](mailto:teva.vernoux@ens-lyon.fr))

### Abstract

How cells acquire their identities and grow coordinately within a tissue is a fundamental question to understand plant development. In angiosperms, the shoot apical meristem (SAM) is a multicellular tissue containing a stem cell niche, which activity allows for a dynamic equilibrium between maintenance of stem cells and production of differentiated cells that are incorporated in new aerial tissues and lateral organs produced in the SAM. Plant hormones are small molecule signals controlling many aspects of plant development and physiology. Several hormones are essential regulators of SAM activities. This review highlights current advances that are starting to decipher the complex mechanisms underlying the hormonal control of cell identity and growth in the SAM.

**Keywords:** cell identity, growth, cytokinins, auxin, gibberellins, shoot apical meristem

## **Introduction**

Cell identities result from progressive changes in transcriptional activities that modify the cellular states, a process that is controlled by regulatory networks involving signalling molecules and transcriptional factors, as well as epigenetic modifications [1]. The changes in cellular states determine also changes in tissue growth, through a regulation of cell division and cell expansion, which are key for morphogenesis [2].

In higher plant, the shoot apical meristem (SAM) is a dome-shaped multicellular tissue located at the shoot tip that elaborates, during the entire lifespan, all the aboveground structures, such as leaves, flowers, stems and axillary branches (reviewed in [3–5]). This ability is linked to the existence of a group of stem cells in the central zone (CZ) and of an organizing center (OC) located below the CZ in the rib zone (RZ) that together constitutes a stem cell niche. Following division, daughter cells from the stem cells at the boundary of the CZ are displaced to the peripheral zone (PZ), where cells enter differentiation programs specific of organ primordia or of all tissues located between lateral organ primordia. The activity of the CZ stem cells also maintains the RZ, that, together with the inter-primordia regions from the PZ, constructs the internode, the stem segments that bear the lateral organs. The SAM thus exemplifies the need to coordinate cell identity determination and growth during the plant structure construction.

Amongst the many signals involved in plant development, phytohormones play a role in almost all aspects and several of them are crucial for the SAM activity. Here we mainly discuss recent findings that have pushed the frontier of our understanding of the role of phytohormones, mainly cytokinins (CKs), auxin and gibberellins (GA) in the regulation of cell fate and growth in the SAM.

## **Hormonal control of stem cell fate**

One of the best characterized regulatory networks that control the stem cell identity in the SAM is a negative feedback loop involving the peptide ligand CLAVATA3 (CLV3) secreted from the stem cells in the CZ [6], and the homeodomain transcription factor WUSCHEL (WUS) produced in the OC [7,8]. WUS activates stem cell fate non-cell-autonomously through intracellular protein movement [9,10]. CLV3 is perceived by receptor complexes involving CLV1/CLV2/CORYNE and represses *WUS* expression [11–13]. This regulatory loop, regulating stem cell number and stem cell niche size is tightly integrated with phytohormone signalling.

CKs are a family of phytohormones that regulate cell proliferation and that are important for meristematic cell fate specification (see reviews in [14]). CK biosynthetic mutants have smaller meristems while catabolic mutants have bigger ones [15]. High levels of CK-induced transcriptional activity largely overlap with *WUS* expression domain in the inner part of the SAM [14\*,16,\*\*17]. While we have known for some time that CK signalling is required to activate *WUS* expression in the SAM [16], it is only recently that the molecular mechanisms involved have started to be elucidated. In *Arabidopsis*, CK signalling is mediated by the type B Arabidopsis Response Regulators (ARR) transcription factors and the type-B ARRs ARR1, 10, 12 have been shown to directly bind the promoter of *WUS* and activate *WUS* transcription [18\*, 19\*\*–23]. Type-B ARRs can also activate the expression of the genes encoding type-A ARRs *ARR7* and *ARR15*, which are repressors of CK signalling pathway that can downregulate *WUS* expression [24]. Therefore, this indicates a dual mechanism of activation/repression of *WUS* expression through CK signalling that act in fine-tuning *WUS* activity, and then stem cell

fate. *WUS*, in turn, was previously found to directly repress the transcription of several type-A *ARR* genes (*ARR5*, *ARR6*, *ARR7* and *ARR15*) [25], therefore forming another positive-feedback loop between CK signalling and *WUS* expression (Figure 1). How this intricate network of interactions between CK and *WUS* functions spatially is still to be deciphered.

CKs also mediate the modulation of stem cell activity in response to environmental cues, such as light and nitrogen, through regulation of *WUS* expression (Figure 1). CK catabolism gene *CYTOKININ OXIDASE5* (*CKX5*) has been previously reported to be a direct transcriptional target of several PHYTOCHROME INTERACTING FACTORS (PIFs), whose activity are inhibited by light [26]. It was recently shown that *WUS* expression is activated in the *ckx5 ckx6* double mutant under darkness, suggesting that *CKX5* and *CKX6* activities lead to *WUS* expression repression through CK degradation in the dark [27]. Together, these works identify CKs as relays of light signals from light-sensing sites to the SAM where it regulates *WUS* expression and stem cell activity [27]. Changes in stem cell homeostasis in response to nitrogen availability in the soil also relies on CK metabolism regulation but involves biosynthesis enzymes [15]. Grafting experiment showed that CK precursors (tRZ), produced by biosynthesis ISOPENTENYL TRANSFERASE (IPT) enzymes, can act as long-distance signals transported from roots to shoots. tRZ is then converted into active CK by LONELY GUY (LOG) biosynthesis enzymes in the SAM, leading to *WUS* expression activation [15]. In addition, a very recent work in barley has shown that *CKX3* is targeted by the barley SEPALLATA MADS-box protein HvMADS1 in response to high ambient temperature and that maintaining low levels of CK signalling positively regulate meristem determinacy in spike development [28].

The epidermal expression pattern of *LOG4* leads to the view that epidermis-derived active CK

perceived by CK receptors located in the RZ could form an apical-basal CK signalling activity gradient in the growing SAM (Figure 1) [29]. Given the role of CKs in regulating *WUS* expression discussed above, this gradient, together with the CLV signalling pathway, could set the spatial position of *WUS* domain within the SAM [29]. Combining wet experiments and computational modeling, Gruel et al. also showed that this CK signalling gradient create an epidermic driving force that scales the *WUS* expression domain to the SAM size [30]. However, our knowledge on these mechanisms is still limited by the absence of information on CK distribution in the SAM. This distribution could be complex as CKs are also transported actively within the SAM [31,32].

In addition to CK, a role for auxin in stem cell fate maintenance has recently emerged. While auxin is present at high concentrations in the CZ as well as at specific locations in the PZ, only a minimal auxin response is observed in the CZ using a DR5 auxin-inducible reporter (Figure 2a-b) [33\*–36]. However, this minimal auxin response is still required to maintain the stem cell niche activity. Long-term ectopic expression of an auxin signalling repressor in the stem cells resulted in meristem termination [33\*]. *WUS* orchestrates auxin signalling in the stem cell region via the regulation of histone acetylation of loci encoding genes involved in the auxin signalling pathway and in auxin responses [33\*]. This confers stem cells with the ability to resist auxin-induced differentiation and to keep a stem cell fate, while maintaining a minimal activity of auxin signalling [33\*]. Another work provides a molecular mechanism explaining how low levels of auxin signalling in the SAM help maintaining the stem cell fate. The AUXIN RESPONSE FACTOR5/MONOPTEROS (*ARF5/MP*) mediates auxin signalling responses in the PZ but is also present in the CZ [24]. It was found that *ARF5/MP* binds directly to the

promoter of *DORNROSCHEN* (*DRN*) and represses its activity [37\*\*]. *DRN* encodes a transcriptional factor expressed in the center of the meristem and capable of upregulating *CLV3* expression, suggesting a mechanism where ARF5/MP-mediated auxin signalling participates to controlling stem cell activity through the regulation of *DRN* expression [37\*\*]. This provides a scenario where a minimal auxin signalling activity in the CZ is established by WUS and this activity requires ARF5/MP to fine-tune *CLV3* activity, helping regulation of stem cell homeostasis (Figure 2c).

Live imaging with the DII-VENUS auxin biosensor indicates a low-auxin level region around the OC [38\*]. Genetic and pharmacological analyses revealed a negative correlation between auxin levels in this region and SAM size. Further time-lapsed imaging revealed that it is changes in CZ to PZ differentiation rather than changes in CZ cell division activity explain changes in SAM size upon auxin treatment [38\*]. The authors next combined computational simulation with wet experiments to demonstrate that auxin transport in the inner tissues forms an auxin switch. Similar to the mechanism of apical dominance, weaker auxin efflux within the SAM is inhibited by the stronger auxin efflux in the lateral organs, and thus maintain the auxin level in the SAM, regulating SAM size [38\*].

Alongside the role of CK and auxin, a long standing view is that low levels of GAs are required to maintain the undifferentiated status of the vegetative SAM [39,40]. A very recent work where the expression dynamics of *GA20ox2* and *GA2ox4*, two key genes encoding GA biosynthesis and catabolism enzymes respectively, were analyzed confirmed this [41\*\*]. The authors also observed increased *GA20ox2* and decreased *GA2ox4* expression during floral transition, indicating high levels of GA are however required for later SAM development (see below).

### **Hormonal control of organ primordia cell fate**

Strong evidences have been provided during the past twenty years that a spatio-temporal distribution of auxin regulated by auxin transportation and biosynthesis is essential for primordia initiation via an action on cell differentiation ([42,43], reviewed in [4,44]). A recent work, taking advantage of new pipelines for quantitative imaging and computational analysis, has now demonstrated that auxin could carry a temporal information triggering primordia cell differentiation and controlling organ patterning in the SAM [45\*\*]. Using a ratiometric version of the DII-VENUS, the authors observed not only that spatio-temporal auxin distribution follows precise patterns providing positional information to SAM cells but, unexpectedly, also that centrifugal waves of auxin move through the tissue at a speed higher than growth. As a result of this, cells in the PZ experience dynamic changes in auxin concentration and it is only at positions where cells are being exposed to auxin for a certain period of time that auxin-dependent transcription (detected with DR5 expression) is activated, triggering primordia initiation [45\*\*].

Another study, this time in sepals, also highlights the importance of temporal control of hormone signalling. Inner sepals do not initiate as soon as the auxin signalling marker DR5 indicates auxin signalling activation but rather when the DR5 and the CK response reporter TCS expression domains overlap in the inner layers at the site of the incipient sepal primordia [46]. Perturbing the moment when these two expression domains overlap resulted in delayed inner sepal initiation in the *development related myb-like 1 (drmy1)* mutant and in sepal size defects. This work thus suggests that the relative timing of auxin and CK signalling is under



the control of the *DRMY1* gene and that proper timing of sepal initiation and growth, is essential to determine organ size [46].

Organ fate determination not only relies on hormonal cues required to initiate the organogenesis program but also on repression of the meristematic genes, allowing to turn pluripotent meristematic cells from the PZ into organs. It was recently shown that auxin is also involved in this repression [47\*\*]. Chung et al., found that the *SHOOTMERISTEMLESS (STM)* pluripotency gene is inhibited indirectly by ARF5/MP through the action of its target *FILAMENTOUS FLOWER (FIL)* and directly by two other members of the ARF transcription factor family that act as repressors, ARF3/ETTIN (ETT) and ARF4 (Figure 2c). This inhibition is achieved through recruitment of the histone deacetylase HDA19, which forms a co-repressor complex with FIL/ETT/ARF4 [47\*\*]. This provide yet another example where regulation of histone acetylation is central to cellular state transition in the meristem and thus to meristematic function.

### **Hormonal control of growth in the SAM**

Together with cell fate specification, growth is playing a key role in organogenesis in the SAM but is still partly understood. Several recent findings have however extended our knowledge of hormonal control of growth in the SAM. Yang et al. discovered a long sought molecular mechanism underlying the regulation of cell division by CK in the SAM of *Arabidopsis* [48\*\*]. They demonstrated that at the G2/M transition, high levels of CK promote a fast nuclear trafficking of the Myb-domain protein 3R4 (MYB3R4), a transcriptional factor activating mitosis gene expression. Constitutive addressing of MYB3R4 to nuclei is able to partially

phenocopy the effects of increased CK concentration on cell division and on SAM growth. Two importin genes, expressed in the SAM and involved in the recognition of targets for nuclear importing, are in turn directly activated by MYB3R1 and MYB3R4, thus forming a positive feedback loop ensuring a faster and stronger nuclear shuttling [48\*\*].

As mentioned above, Kinoshita et al. found that GA distribution in the SAM shows quite dynamic changes that parallel changes in growth dynamics of the SAM (Figure 3a-b) [41\*\*]. Notably at the floral transition stage, high levels of GA, conferred by increased GA20ox2 and decreased GA2ox4 enzyme activity, promote both cell division and expansion in the SAM epidermis to form the doming shape characteristic of the SAM at the inflorescence stage (Figure 3c). It is worth mentioning that this action on cell growth by GA was found to be integrated with environmental regulation, here day length [41\*\*]. Consistent with a positive role of GA in SAM growth during inflorescence development, Serrano-Mislata et al. found that, in the RZ, the DELLA GA signalling repressors directly bind to and promote the expression of the cell cycle inhibitor gene *KIP-RELATED PROTEIN2 (KRP2)* (Figure 3c) [49\*]. Mutations in *KRP2* could rescue the smaller SAM size of the dominant negative *gai* mutant, in which GA signalling is constitutively repressed [49\*].

## **Conclusions**

With the development of tools for precise quantitative imaging and powerful analysis pipelines, we are getting a more and more accurate vision of the patterns of hormone and hormone signalling distribution in the SAM. This allows to precisely identify when and where hormones are active, which is essential information given the complexity of the implication of hormones

in regulating SAM function. We have highlighted works providing such information and it will certainly be interesting to extend our knowledge on hormone distribution using the multiple sensors that are now available [50]. A very recent work using flower as a study model exemplified a way to construct and test the potential complex regulatory networks underlying hormonal control of cell identity and growth in the SAM [51].

Additionally, single-cell RNA-seq [52,53] could be combined with spatial transcriptomics [54,55] to provide whole genome information at the cellular scale in the SAM. This will certainly help pushing the frontier of our understanding of hormonal cell fate specification by enabling discovery of how cell differentiation trajectories are shaped by hormones.

#### **Declaration of competing interest**

Nothing declared.

#### **Acknowledgements**

We thank our colleagues from the Laboratoire Reproduction et Développement des Plantes for fruitful discussions on the topic of this review. This work was supported by the ANR-16-CE13-0014 (GrowthDynamics) grant to T.V.

## References and recommended reading

Papers of particular interest, published within the period of review, have been highlighted as:

\* of special interest

\*\* of outstanding interest

1. Xu X, Smaczniak C, Muino JM, Kaufmann K: **Cell identity specification in plants: lessons from flower development.** *Journal of Experimental Botany* 2021, **72**:4202–4217.
2. Vernoux T, Besnard F, Godin C: **What shoots can teach about theories of plant form.** *Nat Plants* 2021, **7**:716–724.
3. Barton MK: **Twenty years on: The inner workings of the shoot apical meristem, a developmental dynamo.** *Developmental Biology* 2010, **341**:95–113.
4. Shi B, Vernoux T: **Chapter Four - Patterning at the shoot apical meristem and phyllotaxis.** In *Current Topics in Developmental Biology*. Edited by Grossniklaus U. Academic Press; 2019:81–107.
5. Wu Q, Xu F, Jackson D: **All together now, a magical mystery tour of the maize shoot meristem.** *Current Opinion in Plant Biology* 2018, **45**:26–35.
6. Fletcher JC, Brand U, Running MP, Simon R, Meyerowitz EM: **Signaling of cell fate decisions by *CLAVATA3* in *Arabidopsis* shoot meristems.** *Science* 1999, **283**:1911–1914.
7. Mayer KFX, Schoof H, Haecker A, Lenhard M, Jürgens G, Laux T: **Role of *WUSCHEL* in regulating stem cell fate in the *Arabidopsis* shoot meristem.** *Cell* 1998, **95**:805–815.

8. Lopes FL, Galvan-Ampudia C, Landrein B: **WUSCHEL in the shoot apical meristem: old player, new tricks.** *Journal of Experimental Botany* 2021, **72**:1527–1535.
9. Yadav RK, Perales M, Gruel J, Girke T, Jönsson H, Reddy GV: **WUSCHEL protein movement mediates stem cell homeostasis in the *Arabidopsis* shoot apex.** *Genes Dev* 2011, **25**:2025–2030.
10. Yadav RK, Reddy GV: **WUSCHEL protein movement and stem cell homeostasis.** *Plant Signaling & Behavior* 2012, **7**:592–594.
11. Jeong S, Trotochaud AE, Clark SE: **The *Arabidopsis* CLAVATA2 gene encodes a receptor-like protein required for the stability of the CLAVATA1 receptor-like kinase.** *The Plant Cell* 1999, **11**:1925–1933.
12. Müller R, Bleckmann A, Simon R: **The receptor kinase CORYNE of *Arabidopsis* transmits the stem cell-limiting signal CLAVATA3 independently of CLAVATA1.** *Plant Cell* 2008, **20**:934–946.
13. Clark SE, Williams RW, Meyerowitz EM: **The CLAVATA1 gene encodes a putative receptor kinase that controls shoot and floral meristem size in *Arabidopsis*.** *Cell* 1997, **89**:575–585.
14. Kieber JJ, Schaller GE: **Cytokinin signaling in plant development.** *Development* 2018, **145**.
15. Landrein B, Formosa-Jordan P, Malivert A, Schuster C, Melnyk CW, Yang W, Turnbull C, Meyerowitz EM, Locke JCW, Jönsson H: **Nitrate modulates stem cell dynamics in *Arabidopsis* shoot meristems through cytokinins.** *PNAS* 2018,

115:1382–1387.

16. Gordon SP, Chickarmane VS, Ohno C, Meyerowitz EM: **Multiple feedback loops through cytokinin signaling control stem cell number within the *Arabidopsis* shoot meristem.** *PNAS* 2009, **106**:16529–16534.

17. Snipes SA, Rodriguez K, DeVries AE, Miyawaki KN, Perales M, Xie M, Reddy GV: **Cytokinin stabilizes WUSCHEL by acting on the protein domains required for nuclear enrichment and transcription.** *PLoS Genetics* 2018, **14**:e1007351.

18. Meng WJ, Cheng ZJ, Sang YL, Zhang MM, Rong XF, Wang ZW, Tang YY, Zhang XS: **Type-B ARABIDOPSIS RESPONSE REGULATORS specify the shoot stem cell niche by dual regulation of *WUSCHEL*.** *Plant Cell* 2017, **29**:1357–1372.

\* The authors showed that type-B ARR1, ARR10, and ARR12 directly activate the transcription of *WUS* and repress *YUCCA* auxin biosynthesis gene expression, which indirectly promotes *WUS* transcription during shoot generation. This study adds key missing bricks to the bridge between CK signaling and *WUS* expression.

19. Xie M, Chen H, Huang L, O’Neil RC, Shokhirev MN, Ecker JR: **A B-ARR-mediated cytokinin transcriptional network directs hormone cross-regulation and shoot development.** *Nature Communications* 2018, **9**:1604.

\*\*A genome-wide identification and functional classification of the targets of three type-B ARRs (B-ARRs), ARR1, ARR10, and ARR12 was performed using ChIP-seq and a CK response transcriptional network was constructed. Interestingly, A-type ARRs are found to be bound by B-ARRs representing fine-tuned negative feedback regulation of CK response. Furthermore, the authors find that *WUS* is a direct target of B-ARRs in stem cell maintenance.

20. Zhang T-Q, Lian H, Zhou C-M, Xu L, Jiao Y, Wang J-W: **A two-step model for de novo activation of *WUSCHEL* during plant shoot regeneration.** *The Plant Cell* 2017, **29**:1073–1087.
21. Dai X, Liu Z, Qiao M, Li J, Li S, Xiang F: **ARR12 promotes de novo shoot regeneration in *Arabidopsis thaliana* via activation of *WUSCHEL* expression.** *Journal of Integrative Plant Biology* 2017, **59**:747–758.
22. Zubo YO, Blakley IC, Yamburenko MV, Worthen JM, Street IH, Franco-Zorrilla JM, Zhang W, Hill K, Raines T, Solano R, et al.: **Cytokinin induces genome-wide binding of the type-B response regulator ARR10 to regulate growth and development in *Arabidopsis*.** *PNAS* 2017, **114**:E5995–E6004.
23. Wang J, Tian C, Zhang C, Shi B, Cao X, Zhang T-Q, Zhao Z, Wang J-W, Jiao Y: **Cytokinin signaling activates *WUSCHEL* expression during axillary meristem initiation.** *The Plant Cell* 2017, **29**:1373–1387.
24. Zhao Z, Andersen SU, Ljung K, Dolezal K, Miotk A, Schultheiss SJ, Lohmann JU: **Hormonal control of the shoot stem-cell niche.** *Nature* 2010, **465**:1089–1092.
25. Leibfried A, To JPC, Busch W, Stehling S, Kehle A, Demar M, Kieber JJ, Lohmann JU: **WUSCHEL controls meristem function by direct regulation of cytokinin-inducible response regulators.** *Nature* 2005, **438**:1172–1175.
26. Zhang Y, Mayba O, Pfeiffer A, Shi H, Tepperman JM, Speed TP, Quail PH: **A quartet of PIF bHLH factors provides a transcriptionally centered signaling hub that regulates seedling morphogenesis through differential expression-patterning of shared target genes in *Arabidopsis*.** *PLOS Genetics* 2013, **9**:e1003244.

27. Pfeiffer A, Janocha D, Dong Y, Medzihradzky A, Schöne S, Daum G, Suzaki T, Forner J, Langenecker T, Rempel E, et al.: **Integration of light and metabolic signals for stem cell activation at the shoot apical meristem.** *eLife* 2016, **5**:e17023.
28. Li G, Kuijter HNJ, Yang X, Liu H, Shen C, Shi J, Betts N, Tucker MR, Liang W, Waugh R, et al.: **MADS1 maintains barley spike morphology at high ambient temperatures.** *Nat Plants* 2021, doi:10.1038/s41477-021-00957-3.
29. Chickarmane VS, Gordon SP, Tarr PT, Heisler MG, Meyerowitz EM: **Cytokinin signaling as a positional cue for patterning the apical–basal axis of the growing *Arabidopsis* shoot meristem.** *PNAS* 2012, **109**:4002–4007.
30. Gruel J, Landrein B, Tarr P, Schuster C, Refahi Y, Sampathkumar A, Hamant O, Meyerowitz EM, Jönsson H: **An epidermis-driven mechanism positions and scales stem cell niches in plants.** *Science Advances* 2016, **2**:e1500989.
31. Anfang M, Shani E: **Transport mechanisms of plant hormones.** *Current Opinion in Plant Biology* 2021, **63**:102055.
32. Zürcher E, Liu J, Donato M di, Geisler M, Müller B: **Plant development regulated by cytokinin sinks.** *Science* 2016, **353**:1027–1030.
33. Ma Y, Miotk A, Šutiković Z, Ermakova O, Wenzl C, Medzihradzky A, Gaillochet C, Forner J, Utan G, Brackmann K, et al.: **WUSCHEL acts as an auxin response rheostat to maintain apical stem cells in *Arabidopsis*.** *Nature Communications* 2019, **10**:5093.

\* Using genomics and genetics, this work demonstrated that *WUS* is required to maintain low levels of auxin signaling in the SAM stem cells. In particular, *WUS* binds to and



downregulates transcription of numerous genes involved in auxin signaling and response through histone deacetylation. This pathway-wide regulation ensures robust resistance of stem cells to differentiation induced by auxin.

34. de Reuille PB, Bohn-Courseau I, Ljung K, Morin H, Carraro N, Godin C, Traas J: **Computer simulations reveal properties of the cell-cell signaling network at the shoot apex in *Arabidopsis***. *PNAS* 2006, **103**:1627–1632.

35. Smith RS, Guyomarc'h S, Mandel T, Reinhardt D, Kuhlemeier C, Prusinkiewicz P: **A plausible model of phyllotaxis**. *PNAS* 2006, **103**:1301–1306.

36. Vernoux T, Brunoud G, Farcot E, Morin V, Van den Daele H, Legrand J, Oliva M, Das P, Larrieu A, Wells D, et al.: **The auxin signalling network translates dynamic input into robust patterning at the shoot apex**. *Molecular Systems Biology* 2011, **7**:508.

37. Luo L, Zeng J, Wu H, Tian Z, Zhao Z: **A molecular framework for auxin-controlled homeostasis of shoot stem cells in *Arabidopsis***. *Molecular Plant* 2018, **11**:899–913.

\*\* This work found that one of the key ARF proteins, MP/ARF5, mediates auxin regulation on stem cell maintenance via the transcriptional repression on the *DRN* gene, which is expressed in the CZ and activates *CLV3* expression. This work provided evidences to the mechanism of how auxin control stem cell homeostasis in the SAM.

38. Shi B, Guo X, Wang Y, Xiong Y, Wang J, Hayashi K, Lei J, Zhang L, Jiao Y: **Feedback from lateral organs controls shoot apical meristem growth by modulating auxin transport**. *Developmental Cell* 2018, **44**:204-216.e6.

\* A negative correlation between auxin activity and SAM size was uncovered. Combining wet experiments and mathematical modelling, this work further proposed a mechanism for the maintenance of auxin concentration in the inner tissue of the SAM via auxin transport.

39. Hay A, Kaur H, Phillips A, Hedden P, Hake S, Tsiantis M: **The Gibberellin pathway mediates KNOTTED1-Type homeobox function in plants with different body plans.** *Current Biology* 2002, **12**:1557–1565.

40. Jasinski S, Piazza P, Craft J, Hay A, Woolley L, Rieu I, Phillips A, Hedden P, Tsiantis M: **KNOX action in *Arabidopsis* is mediated by coordinate regulation of cytokinin and gibberellin activities.** *Current Biology* 2005, **15**:1560–1565.

41. Kinoshita A, Vayssières A, Richter R, Sang Q, Roggen A, van Driel AD, Smith RS, Coupland G: **Regulation of shoot meristem shape by photoperiodic signaling and phytohormones during floral induction of *Arabidopsis*.** *eLife* 2020, **9**:e60661.

\*\* An analysis of the morphological and cellular basis of changes in SAM shape during floral transition. These changes were further shown to be controlled by gene regulatory networks involved in flowering and by GA. Particularly, the expression patterns of GA biosynthesis and catabolism genes are quite dynamic from vegetative and inflorescence meristem and under precise regulation by the SVP/SOC1 TFs.

42. Vernoux T, Kronenberger J, Grandjean O, Laufs P, Traas J: ***PIN-FORMED 1* regulates cell fate at the periphery of the shoot apical meristem.** *Development* 2000, **127**:5157–5165.

43. Reinhardt D, Mandel T, Kuhlemeier C: **Auxin regulates the initiation and radial position of plant lateral organs.** *The Plant Cell* 2000, **12**:507–518.

44. Wang Y, Jiao Y: **Auxin and above-ground meristems**. *Journal of Experimental Botany* 2018, **69**:147–154.

45. Galvan-Ampudia CS, Cerutti G, Legrand J, Brunoud G, Martin-Arevalillo R, Azais R, Bayle V, Moussu S, Wenzl C, Jaillais Y, et al.: **Temporal integration of auxin information for the regulation of patterning**. *eLife* 2020, **9**:e55832.

\*\* Using quantitative imaging, this work reported high-definition maps of auxin distribution within the SAM. It demonstrated that a prolonged exposure to auxin is required to activate the auxin-dependent transcriptional responses triggering organ initiation.

46. Zhu M, Chen W, Mirabet V, Hong L, Bovio S, Strauss S, Schwarz EM, Tsugawa S, Wang Z, Smith RS, et al.: **Robust organ size requires robust timing of initiation orchestrated by focused auxin and cytokinin signalling**. *Nat Plants* 2020, **6**:686–698.

47. Chung Y, Zhu Y, Wu M-F, Simonini S, Kuhn A, Armenta-Medina A, Jin R, Østergaard L, Gillmor CS, Wagner D: **Auxin Response Factors promote organogenesis by chromatin-mediated repression of the pluripotency gene *SHOOTMERISTEMLESS***. *Nat Commun* 2019, **10**:886.

\*\*This work identified mechanisms underlying STM repression during organogenesis. The authors found that the pluripotency gene *STM* is directly repressed by ARF3 (ETT) and ARF4 and indirectly by ARF5 via the action of FIL. Additionally, the inhibition of *STM* was shown to be achieved through histone deacetylation.

48. Yang W, Cortijo S, Korsbo N, Roszak P, Schiessl K, Gurzadyan A, Wightman R, Jönsson H, Meyerowitz E: **Molecular mechanism of cytokinin-activated cell division in *Arabidopsis***. *Science* 2021, **371**:1350–1355.

\*\*This work demonstrated that MYB3R4, a transcriptional factor targeting core cell cycle genes, mediates the activation of CKs on cell division in the *Arabidopsis* SAM. At the G2/M transition, high levels of CK promotes the quick trans-location of MYB3R4 proteins from cytoplasm to nuclei, initiating gene transcription and driving the cell cycle. Two importins were found to facilitate MYB3R4 nuclear shuttling in a positive feedback loop.

49. Serrano-Mislata A, Bencivenga S, Bush M, Schiessl K, Boden S, Sablowski R: ***DELLA* genes restrict inflorescence meristem function independently of plant height.** *Nature Plants* 2017, **3**:749–754.

\*This work revealed a positive action of GA on SAM size in the inflorescence. Combining quantitative 3D imaging and ChIP-seq technologies, the authors identified the cell-cycle inhibitor KRP2 as a target of the DELLA GA signaling repressors in the RZ. They further shown that this regulation is conserved in barley.

50. Isoda R, Yoshinari A, Ishikawa Y, Sadoine M, Simon R, Frommer WB, Nakamura M: **Sensors for the quantification, localization and analysis of the dynamics of plant hormones.** *The Plant Journal* 2021, **105**:542–557.

51. Refahi Y, Zardilis A, Michelin G, Wightman R, Leggio B, Legrand J, Faure E, Vachez L, Armezzani A, Risson A-E, et al.: **A multiscale analysis of early flower development in *Arabidopsis* provides an integrated view of molecular regulation and growth control.** *Developmental Cell* 2021, **56**:540-556.e8.

52. Zhang T-Q, Chen Y, Wang J-W: **A single-cell analysis of the *Arabidopsis* vegetative shoot apex.** *Developmental Cell* 2021, **56**:1056-1074.e8.

53. Satterlee JW, Strable J, Scanlon MJ: **Plant stem-cell organization and**

**differentiation at single-cell resolution.** *PNAS* 2020, **117**:33689–33699.

54. Giacomello S, Salmén F, Terebieniec BK, Vickovic S, Navarro JF, Alexeyenko A, Reimegård J, McKee LS, Mannapperuma C, Bulone V, et al.: **Spatially resolved transcriptome profiling in model plant species.** *Nature Plants* 2017, **3**:1–11.

55. Lieben L: **Spatial transcriptomics in plants.** *Nat Rev Genet* 2017, **18**:394–394.

**Figure 1. CK and CK signalling distribution and the gene network regulating them in the SAM.**

(a) Schematic of the putative apical-basal active CK gradient in the SAM [29,30].

(b) Schematic of CK signalling activity in the OC of the SAM [16].

(c) The CK signalling-dependent gene regulatory network regulating *WUS* expression requires type-B (activators) and type-A (repressors) ARRs. In turn, *WUS* regulates the expression of type-B and type-A ARRs, constructing intertwined feedback loops that are required for fine-tuning *WUS* expression. CK also relay environmental signals, such as light and nitrogen availability in the soil to control meristematic activity via the regulation of *WUS* expression. Adapted from [15,18,19,24–27].

**Figure 2. Auxin and auxin signalling distribution and the gene network regulating them in the SAM.**

(a,b) Simplified schematic of the auxin (a) and auxin signalling (b) distribution in the SAM based on observations using the current available auxin sensors [33,36,38,45].

(c) The auxin signalling-dependent gene regulatory network acting in the specification of the stem cell niche and of primordia cells and on growth anisotropy. *WUS* in the OC orchestrate auxin signalling in the CZ. The low levels of auxin response permitted by the presence of MP/ARF5 in the CZ ensure repressed *CLV3* activity through the deactivation of DRN transcription. For organ primordia specification, temporal information carried by auxin is essential, as well as the repression of *STM* expression by auxin signalling effectors, ARF3 (ETT), ARF4 and ARF5, respectively. Adapted from [33,37,47].

**Figure 3. GA signalling distribution and the gene network regulating them in the SAM.**

**(a,b)** Schematic of the putative GA signalling distribution in the vegetative (a) and inflorescence (b) SAM . Hypothesized high GA signalling activity sites are marked in green.

**(a)** The activation of the GA catabolic gene *GA2ox4* by STM lead to propose that low levels of GA in the vegetative SAM [40,41]. A potential high GA signalling site at the abaxial side of primordia is suggested by the expression of the GA biosynthetic gene *GA20ox2* [41]. **(b)** High GA signalling sites are predicted from the mapping of genes encoding GA metabolic enzymes and from DELLA activity in the inflorescence SAM [41,49].

**(c)** The DELLA GA signalling effectors activate the expression of KRP2, thus inhibiting cell division in the RZ and in the above cell layers. In the PZ and adaxial side of primordia during floral transition, the GA levels is increased through up- and down-regulation on *GA20ox2* and *GA2ox4* expression, respectively. These changes are regulated by the photoperiod and require the SOC1 and SVP transcriptional factors. Adapted from [41,49].

Figure 1. CK and CK signalling distribution and the gene network regulating them in the SAM.

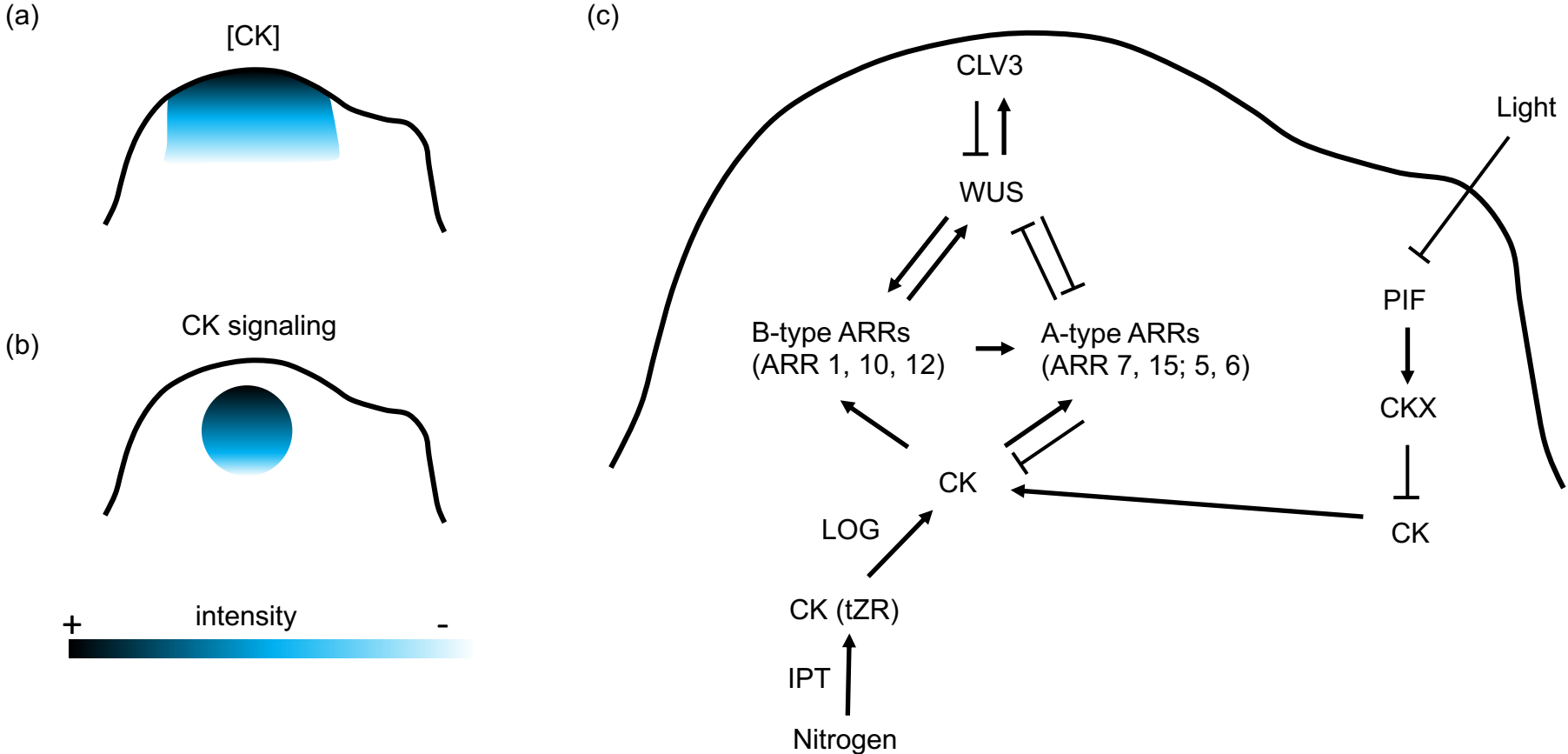



Figure 2. Auxin and auxin signalling distribution and the gene network regulating them in the SAM.

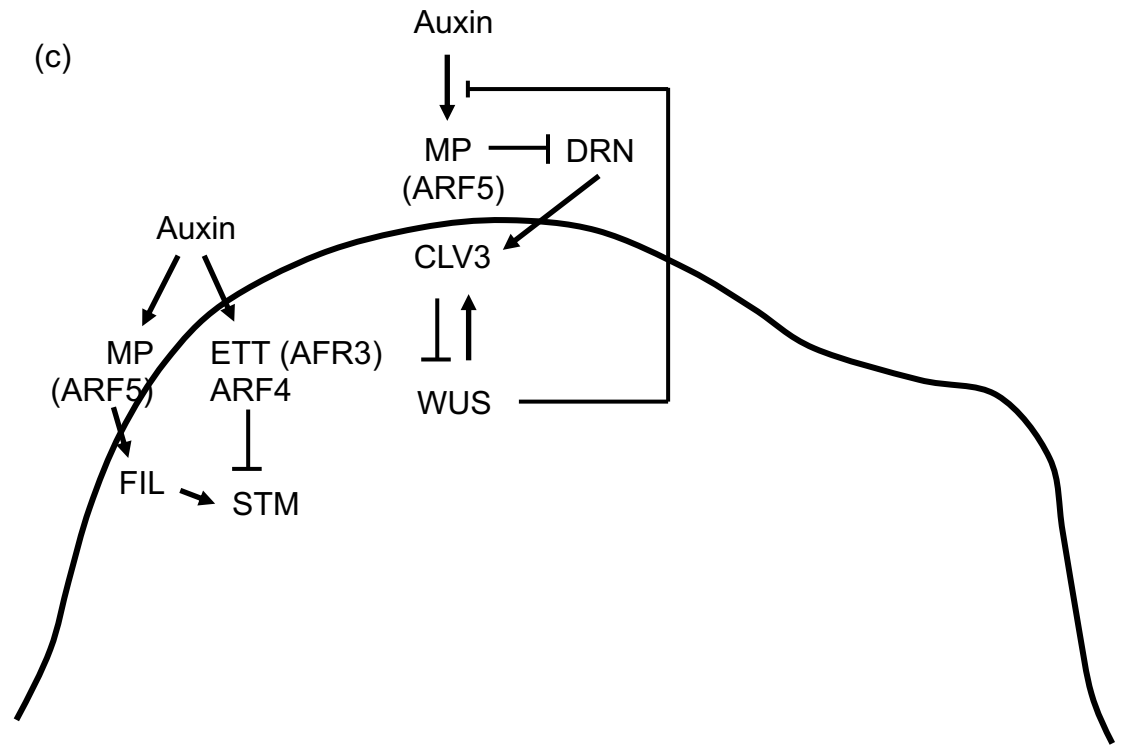
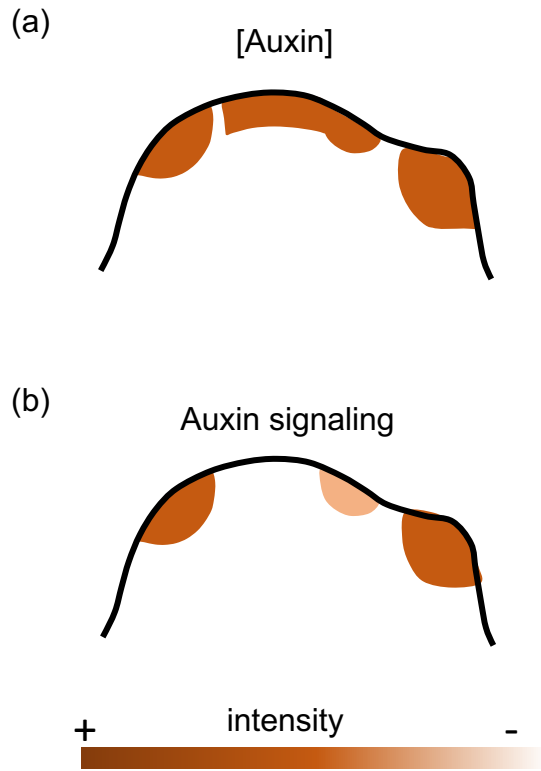

Figure 3. GA signalling distribution and the gene network regulating them in the SAM.

