



HAL
open science

Identifying agricultural areas with potential for city connections: A regional-scale methodology for urban planning

Guy Boussougou Boussougou, Esther Sanz Sanz, Claude Napoléone, Davide Martinetti

► To cite this version:

Guy Boussougou Boussougou, Esther Sanz Sanz, Claude Napoléone, Davide Martinetti. Identifying agricultural areas with potential for city connections: A regional-scale methodology for urban planning. *Land Use Policy*, 2021, 103, pp.105321. 10.1016/j.landusepol.2021.105321 . hal-03784305

HAL Id: hal-03784305

<https://hal.inrae.fr/hal-03784305>

Submitted on 25 Jul 2023

HAL is a multi-disciplinary open access archive for the deposit and dissemination of scientific research documents, whether they are published or not. The documents may come from teaching and research institutions in France or abroad, or from public or private research centers.

L'archive ouverte pluridisciplinaire **HAL**, est destinée au dépôt et à la diffusion de documents scientifiques de niveau recherche, publiés ou non, émanant des établissements d'enseignement et de recherche français ou étrangers, des laboratoires publics ou privés.

Identifying agricultural areas with potential for city connections: a regional-scale methodology for urban planning

1. Introduction

Relocating food supply for cities has become a social and political issue (Duchemin et al., 2010; Arnal et al., 2013; Gallent and Shaw, 2007). It involves assessing the capacity of agricultural areas spatially connected to cities to provide a minimum of commodities for local markets. In most European countries, land-use planning tools are principally based on zoning provisions at municipal level whereas strategic plans are developed at regional level (Reimer et al., 2014). Political injunctions aside, the implementation of a measure supporting short marketing chains or the relocation of farms close to the city raises questions of definition and assessment for public decision-making (region, country, etc.):

- Definition of periurban or local agriculture: the distance from the center alone is not a sufficient criterion (Sanz Sanz et al., 2017 and 2016), since cities may be surrounded by producers involved in long marketing chains, as in the cereal-growing plains around Paris. Moreover, foodstuffs may not exist within the immediate vicinity of a city: for example, cattle farms are not found along the Mediterranean coast in France due to soil and climate conditions.
- Assessment of periurban or local agriculture: the areas spatially connected to cities are characterized by a high degree of complexity related to anthropic developments as well as to the strategies of the different stakeholders (Marraccini et al., 2017), and the weight of local agricultural systems cannot be evaluated on the basis of a single agricultural area identified within a specific distance.

Consequently, most analyses attempting to characterize areas close to cities that offer potential for food supply relocation have been based on qualitative approaches (Duvernoy et al., 2018). These approaches yield specific information on types of agricultural practices and behaviors arising from the relationship between the city and food production, usually providing extensive local implications drawn from the stakeholders (Bertrant et al., 2004). However, qualitative approaches require thorough field work and cannot easily be extended to regions or countries as a whole. For example, while an expert intuitively knows how to prioritize different periurban zones according to their capacity to accommodate farms with short marketing chains, it can be more difficult to properly characterize and quantify the different constituents of that intuition. On the other hand, quantitative approaches enable the same data to be used in other places and are easier to implement. Scientific knowledge provides manifold frameworks for agriculture modeling and assessment oriented towards environmental evaluation for land-use planning

(Helming and Pérez-Soba, 2011; Schaldach and Priess, 2008; Termorshuizen and Opdam, 2009) and rural development (Groot et al., 2009; Lardon, 2012). Some empirical quantitative approach attempt to identify suitable zones for periurban agriculture targeting local economic development, agricultural specializations and market demand, but are partly based on qualitative methods requiring thorough field work (Sanz Sanz et al., 2016; Thapa and Murayama, 2008). However, there is a lack of a spatial approach or method that could be used to characterize periurban farmland at the municipal level. Yet it is at this level that concrete decisions concerning land-use planning are made, in relation to the wider public decision-making at, for example, regional level concerning food supply and short marketing chains.

Here, based on Sanz Sanz et al. (2016, 2018), we describe an original methodology enabling urban and periurban municipalities to be classified according to their agricultural areas' capacity to provide foodstuffs through short marketing chains or their potential as sites to relocate farms connected to the city. Sanz Sanz et al. (2016) provided a methodological framework to characterize periurban agriculture, but whether it could be generalized to the scale of a public action had yet to be determined. To do so, we began with two hypotheses:

- There is a "spatial signature" marking agricultural areas with potential for city connections (Metzger et al., 2006; Sanz Sanz et al., 2016 and 2017). For example, extensive and highly homogeneous areas generally imply monospecific crops intended for processing or export, whereas heterogeneity usually implies smaller farms and more diversified crops that should be easier to orient towards local markets.
- The strategic propensity of producers to be connected to the city is not known at the public action level but is determined by a number of social, political, and economic conditions that can be measured, like market price of land or commodities, presence of an administratively regulated agricultural area, etc.

In this article, we propose a statistical method that makes it possible to identify municipalities encompassing an agricultural area with the potential to be connected to the city, at regional level. We use Partial Least Squares-Path Modeling (PLS-PM), which allows us to estimate the effects of unmeasured elements or latent variables, like the capacity to connect to the city, on the basis of measured data or manifest variables, like price of farmland, agricultural production, infrastructures, etc. We then test our method on a geomorphologically diversified French region, Provence-Alpes-Côte d'Azur, with 3.2 million hectares extending from the Mediterranean coast to the mountains, a large number of municipalities (958), and 25% of its territory used for agriculture. The article proceeds as follows: section two describes the state of the art of the different forms of periurban agricultural and presents the statistical model (PLS-PM); the third section presents our study region and the data available for the implementation of statistical models; the fourth section contains our results and concludes with a discussion.

2. Forms of periurban agriculture

We generally distinguish between two principle types of agriculture according to their relationship to the city. One shows no urban influence on the definition of its marketing strategy, whereas the other is functionally linked to the city or appeared at the same time (Soulard et al., 2017). The first category includes farms that develop long-distance marketing strategies dependent on international prices (Aubry and Kebir, 2013 b) and that are only marginally influenced by the presence or the proximity of the city, e.g., a cereal-producing area around an urban center. The second type of agriculture is characterized by dominant urban influence and can be broken down into the following four categories:

- 1) Farms specialized in high added-value products and with short marketing chains (Zasada, 2011; Zasada et al., 2013b), sometimes oriented towards mass catering (Morgan and Sonnino, 2010; Darly and Aubry, 2014).
- 2) Farms with diversification and pluriactivity strategies looking for additional income sources to compensate for their own lack of profitability (Lange et al., 2013). They provide a wide range of services but that correspond to an urban recreational and environmental demand (Ilbery, 1991; Bailey et al., 2000;

Wilson, 2007), ranging from horse farming and horseback riding services (Elgåker, 2012; Zasada et al, 2013a), to agri-tourism and lodging (Sharpley and Vass, 2006; Yang et al, 2010).

3) Farms with an opportunistic strategy that cultivate temporarily available plots, generally while waiting for their conversion to urban use, thus exchanging the acceptance of land insecurity for a decrease in income (Jouve and Napoléone, 2003; Geniaux et al, 2011; Soulard, 2014).

4) Small and medium-size farms, unstructured, undynamic and uncompetitive, often operated by retirees or dedicated to hobby farming (Busck et al., 2008; Præstholt and Kristensen, 2007), or even subsistence farming (Primdahl, 1999; Zasada, 2011).

Thus, the heterogeneity intrinsic to periurban agriculture makes it difficult to characterize areas within which a public action could be implemented, particularly in view of the possible size of such areas: "large urban areas" (major urban hubs + multipolar municipalities under the influence of a pole + periurban spaces) represented 46.1% of French territory in 2010 (INSEE, 2011). Furthermore, even if the urban influence on farms leads to uncertainty for producers, it is not necessarily negative for agriculture. The increase in urban demography and the corresponding urban sprawl mainly impact agricultural systems close to and connected to cities. This induces changes in historic farms (Pérès, 2007), either due to disorganization or abandonment, or changes conducive to the emergence of new development models (Vaudois, 1994 and 1995) when the proximity of the city provides market opportunities (Donadieu and Fleury, 1997b) or when contact with the city makes farmers more alert to trends in food demand (Bryant and Johnston, 1992).

3. Materials and methods

3.1. The study area: the Provence-Alpes-Côte d'Azur region (France)

We defined a study region using administrative boundaries recognized for planning purposes. In France, regions are responsible for preparing a general strategic plan that outlines their policy priorities and develops a spatial vision for the region, whereas municipalities are responsible for establishing local land-use plans and for issuing building permits. With an average number of 1 735 inhabitants, municipalities in France are among the smallest within the OECD (OECD, 2017). We focus our analysis on the Provence-Alpes-Côte d'Azur (PACA) region. Located in southeastern France, it is bordered to the south by the Mediterranean Sea and to the east by the Italian regions of Liguria and Piedmont (Fig. 1). PACA region encompasses 958 municipalities and its population was 4.9 million in 2014 (INSEE, 2014), making it the seventh most populous region in France.

In 2016, with a GDP of 152.13 billion euros, PACA was the fifth richest region in France and the third in terms of GDP per capita (€30,688 - INSEE, 2014). It contains four urban areas with more than 500,000 inhabitants: Marseille-Aix-en-Provence, Nice-Cannes-Antibes-Grasse, Toulon and Avignon. Morphologically, it is characterized by the highly mountainous terrain of the Southern Alps and by coastal plains with a dry climate. Agriculturally, the region is dominated by the standard Mediterranean vineyards, orchards, market garden crops in lowland areas, whereas livestock farming is preponderant in the mountains. Plant crops represent 2/3 of the regional agricultural income and 78% of the farms are exclusively crop-oriented (compared to 42% at the national level), 17% exclusively livestock-oriented (compared to 35% at the national level) and 5% have a mixed crop-livestock profile (compared to 23% at the national level).

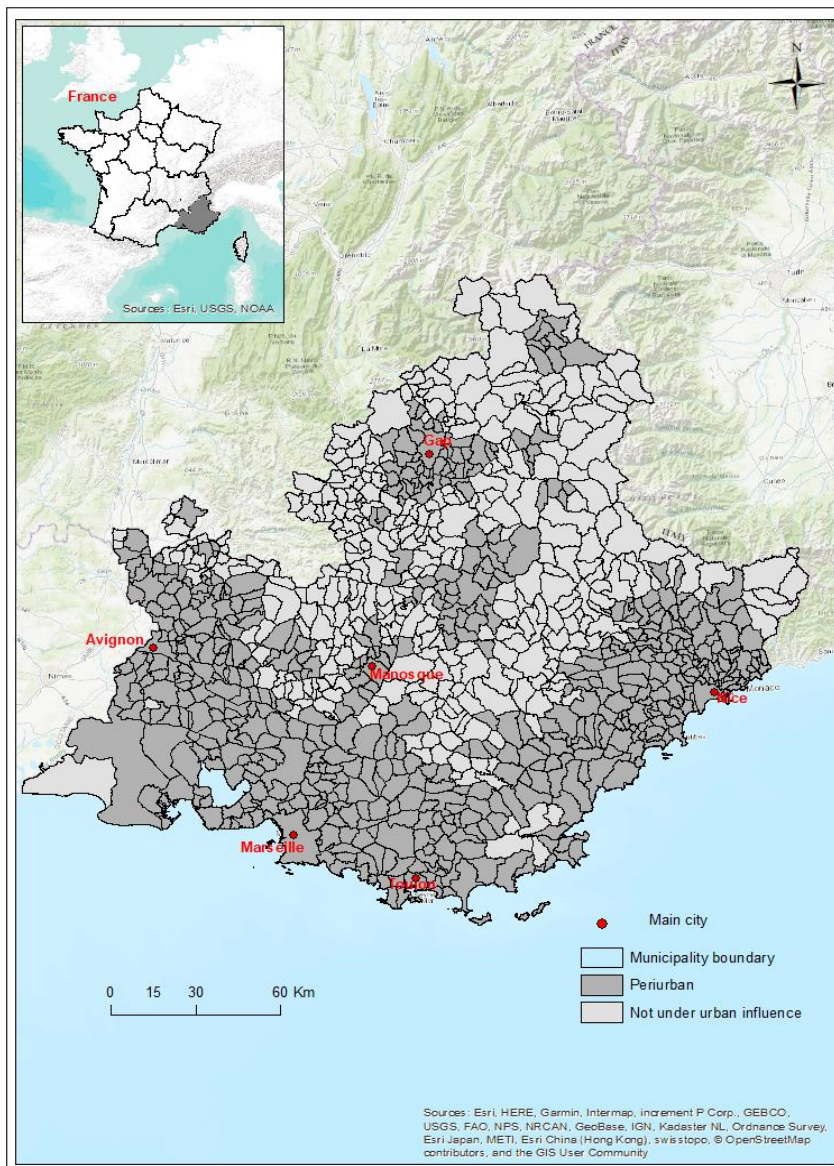

Figure 1: Map of the study area

To select the municipalities of interest here and to reduce calculation time, our study focused on municipalities under urban influence with an active agricultural sector (Fig. 1). For example, municipalities without any agriculture were excluded, as were municipalities not subject to urban influences on the basis of INSEE's urban area zoning (2010). The number of observations of municipalities of interest in our study zone thus decreased from 958 to 530. Note that our case study is based on the communal level because it represents the smallest administrative

territorial division in France. As a result, various national data are available at this scale, making it easier to carry out studies on spatial planning.

3.2. Partial Least Squares-Path modeling (PLS-PM)

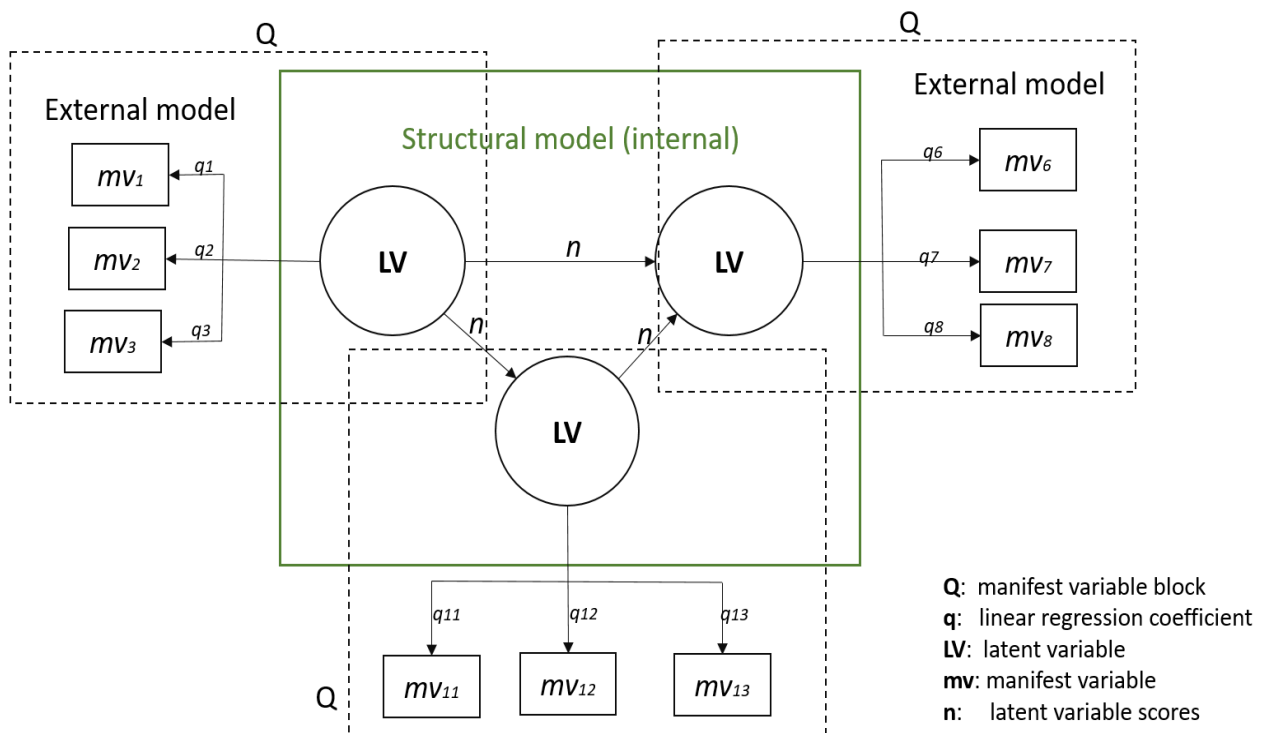

Figure 2: The PLS-PM model.

Links between LVs are quantified using path coefficients (score n), whereas links between LVs and MVs are quantified by weight (q^i - Hair et al., 2014).

The existing technical statistics make it possible to assess agricultural areas' potential for connection to the city. Initially developed for applications in the field of chemistry, PLS regression is used in a wide range of scientific communities (Esposito Vinzi et al., 2008), especially in the humanities and social sciences like econometrics and marketing (Crié, 2005; Lacroux, 2008).

The application of PLS regression to the treatment of structural equation models was originally proposed by Herman Wold (1974, 1982) and recently improved by Dijkstra and Henseler (2015 a and b). It is a structuring technique for complex data tables based on linear relationships. Structural modeling of partial least squares involves a subset of PLS models in which the user characterizes a phenomenon in terms of a theoretical operating and assumption model while defining latent variables linked by path coefficients and measured by one or several manifest variables (Binz et al., 2014; Hair et al., 2014) (fig. 2).

This method takes into account the residual variances for both theoretical and observed variables (Croutsche, 2009). It models non-recursive relationships using an estimation process by regressing the latent variables with their respective indicators and regressing the latent variables with each other (Fernandes, 2012).

First, the latent variables are estimated from the external model (Tenenhaus, 1999). The external estimate Y_j of the latent variable Y_j is constructed as a linear combination of the manifest variables x_{jh} :

$$Y_j = \sum_h W_{jh} X_{jh} = X_j W_j$$

Where w_j is the column vector of the coefficients W_{jh} . The variable Y_j is forced to be centered-reduced.

Then the internal estimation Z_j of the latent variables is carried out from the external estimates Y_i of the latent variables ε_{ij} related to ε_{ij} :

$$Z_j \alpha \sum_{\{i|i \neq j, c_{ij} \neq 0\}} \varepsilon_{ji} Y_i$$

Where the sign means that the variable to the left of this sign is obtained by reducing the variable to the right.

These two steps are repeated until they converge. Then, the model coefficients are estimated by simple or multiple regressions.

Strictly speaking, the method first entails specifying the theoretical model, referred to as structural, and then iteratively estimating the model parameters: the links between unmeasured variables, referred to as latent (LV), represented by their linear regression coefficients, are estimated on the basis of multiple regressions between the variables selected (Fig. 2). They represent the network of causalities between several measured variables, referred to as manifest (MV), while incorporating measurement errors (Bagozzi, 1980). As a result, the structural model is appropriate for exploratory and predictive research while remaining rigorous from a statistical point of view (Hair, Ringle and Sarstedt, 2011; Fernandes, 2012). The structural hypothesis is that of a system of linear relationships between blocks (internal model of measured variables) assumed to take the theoretical operation of the system studied into account. The aim is therefore to maximize the explanatory power of independent variables, i.e., to maximize the covariance between explanatory variables and explained variables (see Sosik et al., 2009). The main contribution of these methods is to provide a simultaneous estimation of several relationships of dependence, while taking measurement errors into account (Roussel et al., 2002).

The treatment of structural equation models includes several standardized steps (Kline, 2005): it must be linear and recursive; observations must be independent of each other; and the relationship between LV and MV must be either reflective or formative (Diamantopoulos and Winklhofer, 2001; Jarvis et al., 2003). Latent variables are said to be reflective when they are considered the cause of manifest variables. The relationship must therefore be unidimensional (Gaston, 2013), i.e., always having the same sign. Latent variables are said to be formative when they are determined by manifest variables. The relationship can then be pluridimensional. The estimation of the parameters of the PLS model consists of four major steps (Tenenhaus and Esposito-Vinzi, 2005; Esposito-Vinzi, Trinchera and Amato, 2010):

- 1) Evaluation of the reliability of variables using Dillon-Goldstein's rho.
- 2) Verifications of the unidimensionality of the model in the case of reflexivity, and estimation of the correlations between manifest and latent variables.
- 3) Evaluation of the convergent validity.
- 4) Evaluation of the discriminant validity.

In our case, the MVs are reflective because we assume that they reflect the phenomenon represented by the LVs. In other words, the latent variable is the cause of the manifest variable (see Lacroux, 2005). Since the literature concerning the application of PLS-PM models is constantly expanding, we chose the following three examples of their use in different fields to illustrate the range of their applications. Sanches et al. (2018) attempted to identify factors leading to loss of biodiversity in rural and urban watersheds; Kumar et al. (2015) attempted to explain the increase in tropospheric ozone as a function of the weather, chemical reactions and other pertinent variables; and

Majdi et al. (2014) evaluated the effect of predators in the food chain. To our knowledge, Partial Least Squares-Path Modeling has never been used to analyze agricultural areas in terms of their potential for connection to the city, although this technique is appropriate for predictive applications in operational environments (Jakobowicz, 2007). An ongoing debate about the validity of the PLS-PM modeling technique (Mcintosh et al. 2014) opposes critics (Rönkkö et Evermann, 2013, Rönkkö et al., 2016) and proponents (Henseler et al., 2014) concerning several technical points and the major issue of comparison against another latent-variable model, Structural Equation Modeling (SEM). However, the PLS approach seems appropriate for our investigation since: 1/it allows non-measurable latent variables to be encoded as expert-informed compositions of measurable ones; 2/ it encompasses previous knowledge on the structural relationship between these latent variables via the inner model; 3/ it is a legitimate method for studies where measurements are not very precise (Tenenhaus, 1999); and 4/ it is more robust than other methods for reduced sample sizes and does not require a normal distribution of baseline data (Balambo, 2014).

The validity of the PLS model can be assessed according to two indicators. The first is a convergent validity measurement taking into account the overall coherence of choice of MVs and LVs and of their structuring, and the second is a bootstrap procedure consisting of a non-parametric approach assessing the precision of estimations of the PLS parameters, which indicates the stability of statistical relationships. The convergent validity of manifest variables is measured taking into account their capacity to influence the latent variables (Drucker et al., 1999), i.e., when MVs are more highly correlated with target LVs than with the other LVs of the model (Lahmouz and Duyck, 2008). The bootstrap procedure is defined as follows: M samples are created in order to obtain M estimations for each parameter of the PLS model. Each sample is obtained by sampling with replacement (drawing with replacement) from the original data set, the size of the sample being equal to the number of cases in the original data set.

3.3. Data: Latent and manifest variables

For the latent variables, based on our previous extensive work on the external and internal driving forces shaping farming system dynamics in the periurban context (Sanz Sanz, 2016; Sanz Sanz et al., 2018, 2017), we assumed that periurban agricultural areas with potential for urban development could be characterized according to five criteria:

- Landscape structure and composition, i.e., the main geophysical elements that influence agricultural activity (altitude, slope, etc.).
- Landscape function, i.e., the type of agriculture (vineyards, market garden crops, livestock farming, etc.).
- Landscape management, i.e. the market drivers influencing land use and preservation of agricultural land.
- Demography, assuming that age, living standard or demographic density influence approaches to and management of periurban agricultural areas, through policies established by the municipalities and validated by a democratic voting process.
- Farms' socio-economic structure, i.e., the type of farms and the way in which they use the land from a spatial or technical point of view.

For the manifest variables, the factors inherent to agriculture or the population can be described by a very large number of candidate variables. We used 27 variables describing agricultural production taken from the French General Agricultural Census (RGA, 2010) and seven from the Population Census (INSEE, 2010). As for factors inherent to landscape structure, candidate variables can be built using spatial analysis but employing various means of calculation: calculation of landscape metrics using land-use data from the French Center for the Study of the Biosphere from Space (CESBIO) (OSO, 2016¹), statistical calculations on slopes and altitudes based on the BD

¹ Land use, 2016:

<http://osr-cesbio.ups-tlse.fr/~oso/posts/2017-03-30-carte-s2-2016/>

ALTI² (IGN), calculations on the road network to determine the length of the network using the BD TOPO³ (IGN). Concerning factors inherent to landscape management, it is worthy of note that we did not consider variables related to European Common Agricultural Policies (CAP) because agriculture in the study area does not receive many CAP subsidies. Actually, farms located in the French Mediterranean region receive the lowest share of agricultural subsidies (<8%), whereas the profits of the mainly livestock- and cropping-oriented farms in other regions in France are derived up to 47% from subsidies (Chemnitz, 2019). Thus, farmers' strategies aimed at connecting to cities are not driven by CAP incentives but mainly by market prices or infrastructure, or by land-use policies.

We identified 86 manifest variables that describe the latent variables (see Appendix B). Clearly, there needs to be some selection of manifest variables, which we based on an estimation of the similarity of information contributed by the MVs, by block of LVs. It is based on correlation matrices (Fig. 3 for example – all correlation matrices are presented in Appendix A) from which we retained the most significant variables and eliminated the secondary variables correlated at more than 70%. We kept 25 significant variables out of the 86 candidate variables (Table 1): seven explain landscape structure and composition, five explain landscape function, two take landscape management into account, three explain demography and eight explain farm socio-economic structure.

Table 1: Significant latent and manifest variables (see the set of candidate MVs in the Appendix).

Latent variables	mv code	mv description	Sources
Landscape structure and composition: Natural and/or anthropic components of the landscape of a geographic area	L_TOT_R	Total length of roads per municipality in kilometers	BD TOPO® IGN
	max_P	Maximum slope (%)	BD ALTI® IGN
	pz11	Percentage of farmland	CESBIO (OSO, 2016)
	pz13	Percentage of area under vines	
	pz14	Percentage of area with natural cover	
	pz15	Percentage of urbanized area	
	Shdi	Shannon's Diversity Index	
Landscape function: share of each crop cultivated	CULT_0800	Total vine area (ares)	French General Agricultural Census (RGA, 2010)
	CULT_1000	Total fallow area ⁴ (ares)	
	CULT_0500	Total area of dried or fresh vegetables, strawberries and melons (ares)	
	ELEV_400	Total sheep (number of heads)	
	ELEV_802	Apiculture: quantity of honey produced (kg)	
Landscape management: market drivers	prix_2	Market value of land and pasture 1991-2014 (euros)	Sociétés d'Aménagement Foncier et d'Établissement Rural (SAFER)
	prix_10_16	Average price of land transactions (2010 and 2016) in euros	
Demography:	P10_POP4559	Percentage of the population between 45 and 59 years old	INSEE, 2010 Population Census
	Densite_km	Population density (inhab/km ²)	

² BD ALTI® digital elevation model (DEM):
<http://professionnels.ign.fr/bdalti>

³ BD TOPO is a database at the scale of 1/25,000, providing a vectorial description of the elements and infrastructures of a territory:
<http://professionnels.ign.fr/bdtopo>

⁴ Fallow land designates cropland that is not harvested (AGRESTE – Annual Agricultural Statistics)

population structure or standard of living of households	MED14	Median standard of living (euros/month) * Median standard of living: half of the population will have a higher standard of living and half a lower disposable income.	INSEE-DGFIP-Cnaf-Cnav-CCMSA, Local social and tax register
Farms' socio-economic structure: Characterization of the farm (diversification, technico-economic orientation, type of occupancy, work units)	CIRCOUPAUT	Sale of products via a short marketing chain other than direct sales	French General Agricultural Census (RGA, 2010)
	FORMAGEN_0	Untrained farmer	
	FORMAGEN_1	Farmers with Baccaulaureat (secondary school certificate)	
	FORMAGRI_1	Farmers with a DUT diploma in agriculture (university technological diploma)	
	TERRE_202	Land taken from partners for leasing (ha)	
	OTEX_3500	Farm specialized in winemaking (ares)	
	UTATSai	Annual work unit provided by non-permanent labor (%)	
	Nombre_exploit	Number of farms	

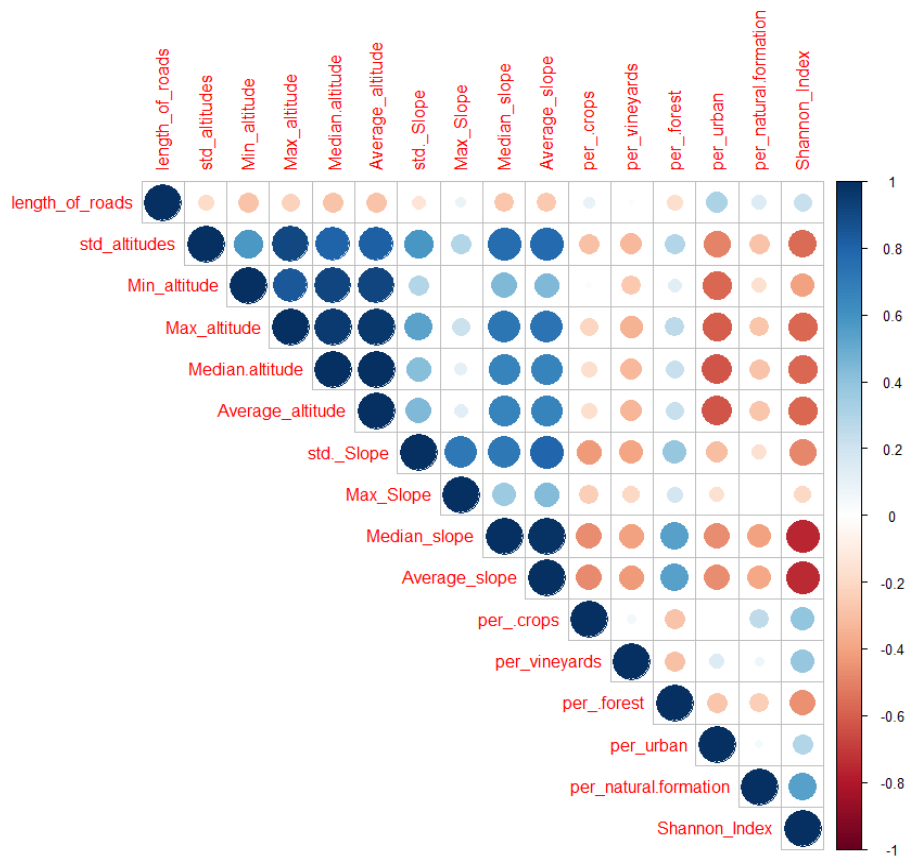

Figure 3: Correlation matrix between MVs for the LV “Landscape structure and composition”.

Per: percentage; max: maximum; min: minimum; std: standard deviation

3.4. Methodological protocol

The Partial Least Squares (PLS-PM)-based approach was implemented according to the following methodological protocol: (1) creation of a database for each spatial unit on the basis of a breakdown of the national territory (in our case, the 530 municipalities), consisting of homogeneous and exhaustive data for France as a whole; (2) application of Least Square Path Modeling (PLS-PM) using R software; (3) spatialization of the PLS-PM model's output using GIS software (Arcgis/Qgis); (4) cluster analysis followed by interpretation of the results and (5) validation of the model and generalizability of the methodology.

The cluster analysis on the results of the modeling approach highlights the most significant variables explaining periurban agriculture and identifies clusters at municipal level that provide opportunities for discussion of regional policies. As for the generalizability of the methodology, the model's architecture allows the sequence of variables used to be adapted to different regional situations: for example, to the geo-morphological context. In this case, the determinants specifically linked to Mediterranean agriculture (access to water) would need to be reconsidered if the region of interest had a more humid climate.

4. Results

4.1. Characterization of periurban agriculture based on the relationships between the latent variables and their manifest variables

The final result of the PLS-PM model estimated from the 25 candidate variables is presented in the form of a diagram that describes the relationships between the LVs and their MVs (Fig. 4). Overall, the diagram drawn from PLS estimations shows that the socio-economic structure of farms significantly and strongly influences (56%) the components of the landscape structure. Moreover, our original assumption that agricultural areas have a "spatial signature" is corroborated: organizational choices in agriculture determine agricultural landscapes, as observed by Rizzo et al. (2013). In addition, the landscape structure and composition has an impact on landscape management as well as on landscape function (42 and 40%, respectively).

On the whole, periurban areas are mainly shaped by the type and the dynamics of the farmers present. The other links between LVs, although they may be weak, make it possible to characterize the complexity of periurban agriculture. The farms' demography and the socio-economic structure thus have an influence, albeit marginal, on landscape function (2 and 6%, respectively). Demography's small degree of influence on landscape function indicates that the nature of periurban agricultural areas is not primarily conditioned by cities' size, but rather by other factors like pedo-climatic characteristics, market pressures, past history, etc. We thus validate our second hypothesis: that the mere presence of a city nearby and/or distance from the center alone is not a sufficient criterion to characterize periurban agriculture.

The relationships between MVs and LVs in terms of farms' socio-economic structure are based on eight manifest variables accounting for the traditional forms of farms in the region studied: winegrowers (OTEX_3500) using seasonal workers (*UTATsai*) in areas that are generally under lease (*TERRE_202*), or short-chain market garden farms (*CIRCOUPAUT*). More interestingly, farm density in the municipalities (*Nombre_exploit*) also plays an important role in the socio-economic structures of farms. There is a direct relationship between the way in which the land resource is distributed between farms and productive practices: short marketing chains and winegrowing have an even greater effect when there are numerous farms, i.e., when farm size is limited.

The landscape structure and composition determinants, unsurprisingly, are road length (*L-TOT_R*) and urban area (*Ps15*), on the one hand, and the main Mediterranean crops (vineyards *-Pz13*; market garden crops *-Pz11*) or

Landscape function encompasses the main types of production present in the study area: vineyards (*CULT_0800*), market garden crops (*CULT_0500*) and sheep farming (*ELEV_400*). Demography is mainly based on population density, taking into consideration the shape of the city (*Densite_Km*), the median standard of living (*MED14*), and the population between 45 and 59 years old (*P10_POP4559*). This last variable should be viewed in the light of studies that have already demonstrated how households within this age group in France accelerate urban expansion by creating the greatest demand for residential housing on the outskirts of cities (Bauer and Roux, 1976).

Finally, it is also possible to differentiate among manifest variables by prioritizing them in terms of their degree of impact within the classification of the USAPs (Spatial Units of Periurban Agriculture). To do this, we use the information gain method (Quinlan, 1986) based on the decision tree of the cluster analysis (Table 2). The most influential manifest variables are vineyard area, percentage of urban-type land use, number of farmers, Shannon's Diversity Index and price of farmland (56; 51; 51; 42;41 and 39 %, respectively), while variables such as apiculture or slopes have weak or null weight. We can also observe that the most influential manifest variables are equally distributed amongst the five latent variables.

Table 2: Information gain from manifest variable

Variable code	Description	Information gain
pz13	Percentage of vineyards	0.56
pz15	% of urban area	0.51
CULT_0800	Total vineyards (ares)	0.51
nombre_exploit	Total number of farmers per municipality	0.42
Shdi	Shannon's Diversity Index	0.41
prix_10_16	Average price of land transactions between 2010 and 2016 (euros)	0.39
prix_2	Maximum land price between 2014_1991. In thousands of euros/ha	0.37
densit_km	Population density of the municipality (inhabitants/km ²)	0.36
CULT_1000	Total fallow land (ares)	0.34
OTEX_3500	Farms specialized in winegrowing (ha)	0.32
MED14	Median standard of living (euros/month)	0.3
L_TOT_R	Total road length per municipality (kilometers)	0.29
FORMAGRI_1	Farmers with a DUT diploma in agriculture (university technological diploma)	0.28
pz11	% of farmland (OSO land use database)	0.22
FORMAGEN_1	Farmers with Baccalaureat (secondary school certificate)	0.20
TERRE_202	Land from partners for renting purposes	0.18
pz14	% of natural formation (land use OSO)	0.17
FORMAGEN_0	Number of farmers with no formal education	0.14

ELEV_400	Total sheep	0.14
CULT_0500	Total area of dried or fresh vegetables, strawberries and melons (ares)	0.13
P10_POP4559	Population aged between 45 and 59 years old	0.10
CIRCOUPAUT	Sales via another short marketing chain	0.10
max_P	Maximum slope in %	0
ELEV_802	Apiculture: quantity of honey produced (kg)	0

4.2. Types of periurban agriculture in the Provence-Alpes-Côte d'Azur region

In a second step, we carried out a cluster analysis of the scores of the latent variables to pinpoint the spatial agricultural units with potential for connection to the cities. Using the dendrogram of the hierarchical cluster analysis (Appendix D), we identified and characterized six classes of spatial units of periurban agriculture (USAP), referred to as A to F (Fig. 5):

USAP_A (low-dynamic mixed livestock): Mixed breeding that is not very dynamic or receptive to any public action from the neighboring municipality. The area is composed of lowly fragmented landscapes⁵ and natural areas⁶ (on average 18% of the area). It is distinguished by a limited urbanized area (approximately 5%). Its agricultural production is oriented towards mixed livestock farming (sheep, apiculture). The municipalities within this category have a small number of farmers (an average of 15 farms per municipality) with little formal education (agricultural or general), and are mainly located in the lowland areas of mountainous regions.

USAP_B (low-dynamic extensive sheep livestock): Extensive breeding not very receptive to any public action from the neighboring municipality. Agricultural systems based on livestock farming primarily focused on sheep. The area is characterized by municipalities with a median standard of living lower than the average and approximately 20% of the population is between 45 and 60 years old.

USAP_C (mountain sheep livestock): High-altitude sheep farming with no potential for connection to the city in terms of the marketing of foodstuffs produced or the relocation of farms. The municipalities in this class have an average standard of living (2,000 euros) and more than 30% of the population is between 45 and 60 years old.

USAP_D (short-circuit-oriented and dynamic farming): Municipalities distinguished by their high population density (200 inhab/km²), high agricultural land prices (prix-2 and prix_10-16) and the presence of a dense road network (L_TOT_R), testifying to the urban character of this USAP. Consequently, it is an area with high potential for connection to the city, through existing short marketing chains in the process of development or relocation to unused residual areas. The landscape is highly fragmented (high Shannon Index). Farms are oriented towards aboriculture and market garden crops (Pz14, cult_500), and some are specialized in winegrowing (Cult_800). Farm products are marketed in short marketing chains and some farmers rent land from associations in their municipalities.

⁵ The fragmentation of a natural ecosystem consists in a landscape (woods, lowlands, forests, etc.) divided into smaller and more isolated units, separated by landscapes transformed by man (cultivated fields, cities, canals, etc.).

⁶ Natural spaces result from the fusion of land-use categories: grasslands, woody moorlands and forests (land cover product (OSO) developed by the CESBIO). The urban area is also the result of the fusion of OSO categories: dense and dispersed urban areas, industrial and commercial zones, roads.

USAP_E (fragmented farming): Highly urbanized areas (almost 50% urban) close to large urban centers like Marseille, Toulon and Nice. Consequently, the areas have strong potential to establish functional links with the city, where institutional incentives could facilitate the creation of new farms on abandoned agricultural areas interwoven into the urban and periurban landscape. This would require public policy provisions such as a guaranteed cultivation period for plots thus made available. The landscapes are highly fragmented (high Shannon Index), with many infrastructures like roads. The municipalities have high human population densities and a high median standard of living, and the cost of land available for farming is rising. Agriculture is mainly arboriculture, with vineyards and vegetables also cultivated to a lesser degree. This class is also distinguished by a small number of farmers and the presence of uncultivated areas (wastelands).

USAP_F (stable vineyard): Urbanized municipalities with population densities of around 100 inhab/km². Agriculture is mainly devoted to winegrowing (almost 60% of the municipality is covered in vineyards). Some of these vineyards have a heritage value and are located within an AOC (Registered Designation of Origin) area. Market gardening areas can be found next to these protected winegrowing areas. Normally, even close to the city, these areas have an internal stability inherent to the profitability of the winegrowing industry and therefore do not offer high potential for transforming existing farms into systems oriented towards local markets.

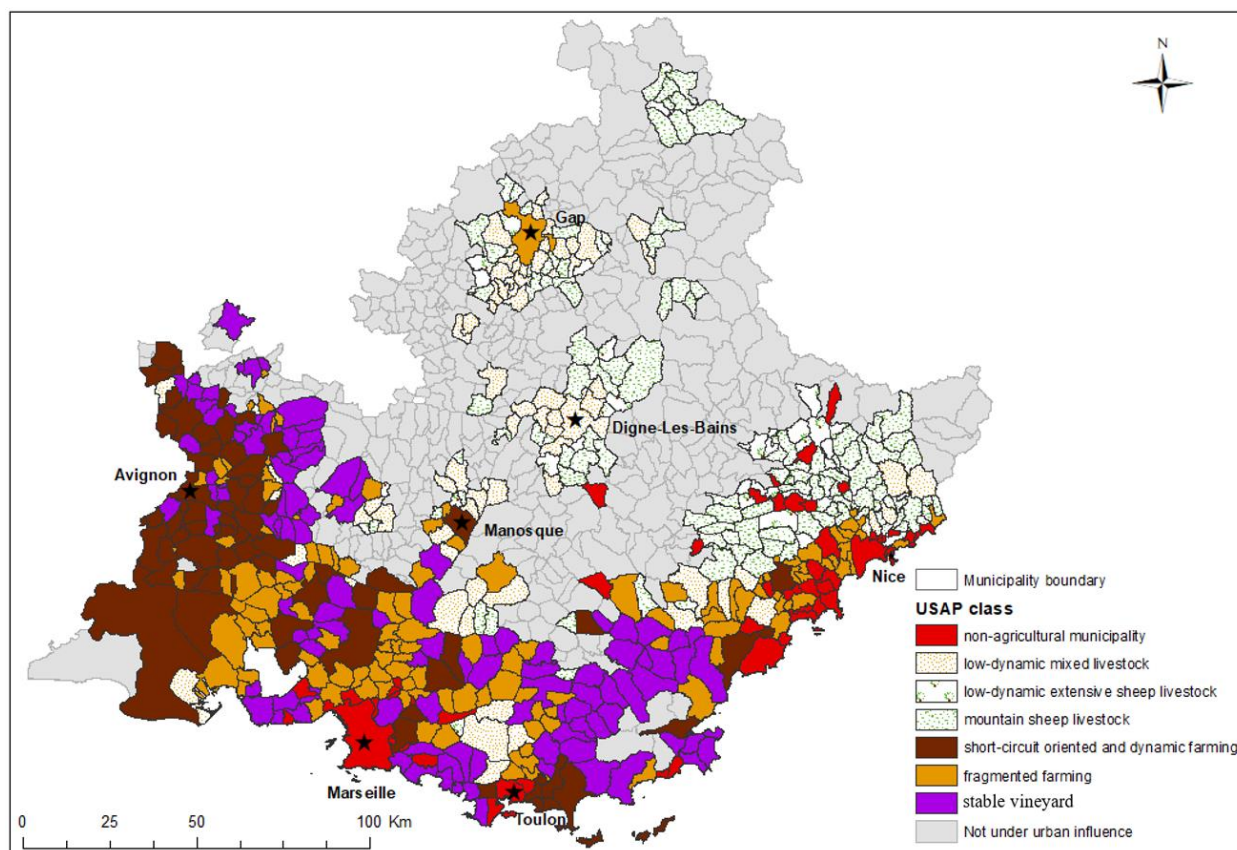

Figure 5: Geographical distribution of the USAPs by municipality - PACA region.

In conclusion, USAPs A, B and C are not subject to urban influence. They represent a type of agriculture that is very heavily dependent on sheep farming. The altitude and the steep slopes as well as the climate that characterizes these geographic areas are major constraints in terms of production and communication systems and limit the extent of areas that can be developed (Nibigira, 1991). On the other hand, municipalities in USAP F are mainly devoted to winegrowing, with vineyards that have a high heritage value. They are mainly located along the Mediterranean coast and in the surrounding countryside directly connected to the coast. Actually, the Basse Provence with its limestone soil is the leading French AOC rosé-producing region, meeting 38% of domestic demand and approximately 8% of global demand. These vineyards are stable and resist urban encroachment due to the stable value of this farmland combined with the varying degrees of protection offered by the AOC designation (Peres, 2007). They develop marketing strategies that, while they do not exclude local sales though short marketing chains, are highly influenced by domestic and international markets, at least in terms of the quantities produced. An illustration can be found in Châteauneuf-du-Pape where, within a context of urbanization, some orchards and vineyards have held out and even gained ground (Lees and Derioz, 1994).

Municipalities in USAP D, with their high population densities, high agricultural land prices, large number of farms and dense urban fabric, show high urban connectivity. Using the typology of Vaudois (1994), we distinguish three types of agricultural area within this USAP: (1) agricultural relics (ex. the city of Hyeres), (2) market-oriented horticultural and market garden areas that have maintained close economic links with the city through very diversified types of short marketing chains (ex. the city of Aix-en-Provence); (3) outward-looking market garden and horticultural areas oriented towards export (ex. the city of Avignon and its surroundings).

Finally, USAP E municipalities are highly urbanized and located close to major urban centers that have more than 10,000 jobs according to INSEE, such as Marseille, Toulon, Manosque and Nice. Farms' proximity to the city leads to production being centered on small and intensive farms that focus more on direct sales (Cavailhès and Wavresky, 2007). Annual crops like durum wheat crops can be seen to be taking over the landscape from vineyards and wasteland or fallow uncultivated land, suggesting that the owners anticipate urban development and are waiting to see what will happen. The advantage of these crops lies both in the low or zero cost of making land available while waiting for urban development, and in the CAP premiums that may be available, as in the Mediterranean area for durum wheat (Tolron, 2001; Jarrige, 2004). These agricultural systems are frequently found in the secondary rings around the major urban centers (Aix-en-Provence, Istres, Meyrargues, Peyrolles-en-Provence, etc.).

4.3. Validation of the measurement model

To validate the PLS model we assessed the validity of the cross-loading measurement model. Table 3 illustrates the correct convergence of the model. In addition, the predictive capacity of the measurement model was evaluated by the bootstrap method, which turns out to be important in our case, revealing that most of the MVs show little variability between the original value and the predicted value (Table 4). The conditions required to ensure the validity of the five reflective LVs are met: homogeneity of scales is sufficient, and both convergent validity (evaluated by factorial contributions, and the extracted average variance and discriminant validity (evaluated by examining correlations between LVs and cross-indexed contributions) are acceptable. Finally, unidimensionality of relationships, expressed by the Dillon-Goldstein coefficient, was verified for the set of LVs (Rho greater than or equal to 0.7). Nevertheless, some of the manifest variables were not statistically validated for the model because they had correlations lower than 0.5. Structural equation models require the contributions to be high (> 0.5) and significant (Roussel et al., 2002).

Table 3: Analysis of the validity of the cross-loading measurement model

Manifest variables	Latent variables	Social structure	Demography	Landscape structure	Landscape management	Landscape function
CIRCOUPAUT	Socio-economic structure of the agricultural farm	0.33	0.04	0.15	0.08	0.09
FORMAGEN_0		0.46	0.15	0.31	0.23	0.13
FORMAGEN_1		0.61	0.25	0.41	0.23	0.30
FORMAGRI_1		0.71	0.09	0.38	0.14	0.17
OTEX_3500		0.62	0.21	0.34	0.17	0.25
TERRE_202		0.54	0.08	0.38	0.19	0.29
UTATsai		0.33	0.06	0.27	0.12	0.12
nombre_exploit		0.75	0.19	0.58	0.27	0.27
densit_km	Demography	0.18	0.71	0.46	0.22	0.21
P10_POP4559		0.18	0.45	0.22	0.10	0.16
MED14		0.16	0.74	0.32	0.44	0.24
L_TOT_R	Landscape structure and composition	0.49	0.32	0.55	0.27	0.17
max_P		0.11	0.08	0.29	0.06	0.08
pz11		0.36	0.08	0.35	0.03	-0.10
pz13		0.43	0.08	0.52	0.28	0.47
pz15		0.38	0.68	0.73	0.44	0.44
pz14		0.27	0.14	0.50	0.28	0.21
Shdi		0.54	0.36	0.84	0.45	0.47
prix_10_16	Landscape Management	0.31	0.14	0.36	0.69	0.29
prix_2		0.23	0.48	0.45	0.85	0.34
CULT_0500	Landscape function	0.12	0.18	0.10	0.05	0.22
CULT_0800		0.35	0.14	0.48	0.35	0.70
CULT_1000		0.15	0.21	0.31	0.23	0.56
ELEV_400		0.20	0.25	0.24	0.23	0.66
ELEV_802		0.11	0.08	0.10	0.07	0.32

Table 4: Bootstrap results on 2000 iterations.

Latent variables	Manifest variables	Original (loading)	Mean.Boot	Std.Error
Socio-economic structure of the agricultural farm	FORMAGEN_0	0.42	0.43	0.05
	FORMAGEN_1	0.60	0.60	0.03
	FORMAGRI_1	0.58	0.59	0.05
	OTEX_3500	0.57	0.58	0.04
	TERRE_202	0.48	0.48	0.04
	UTATsai	0.66	0.66	0.02
	nombre_exploit	0.70	0.71	0.05
Demography	densit_km	0.70	0.70	0.04
	P10_POP4559	0.44	0.45	0.10
	MED14	0.75	0.74	0.04
Landscape structure and composition	L_TOT_R	0.54	0.55	0.05
	max_P	0.29	0.28	0.06
	pz11	0.32	0.33	0.05
	pz13	0.54	0.53	0.03
	pz15	0.74	0.74	0.02
	pz14	0.49	0.50	0.05
	Shdi	0.84	0.84	0.02
Landscape Management	prix_10_16	0.67	0.72	0.08
	prix_2	0.86	0.84	0.04
	CULT_0500	0.19	0.20	0.11
	CULT_0800	0.73	0.72	0.04
	CULT_1000	0.56	0.57	0.06
	ELEV_400	0.64	0.64	0.05
	ELEV_802	0.31	0.29	0.09

To test the generalizability of the methodology, we applied it to another French non-Mediterranean region: Poitou-Charentes. The implementation of the method required the prior selection and expert validation of the manifest variables corresponding to this geographical area (Fig. 6). The detailed description of each USAP of Poitou-Charentes in Appendix E reveals region-specific characteristics. For example, the USAP_I municipalities whose agriculture is primarily oriented towards cattle, sheep, and pig farming (i.e., enclosed breeding, a large part of its produce being sold in long distribution chains in Europe), or the USAP_D municipalities highly oriented towards major field crops marketed in both short and long marketing chains. However, it also reveals a certain number of correspondences between the USAPs of the two regions that suggest continuities in the manner of structuring the relationships between the city and periurban agriculture. We thus find in both regions winegrowing municipalities (F, F1 and F2 in our case) and municipalities that use short marketing chains for their horticultural and market garden products (E).

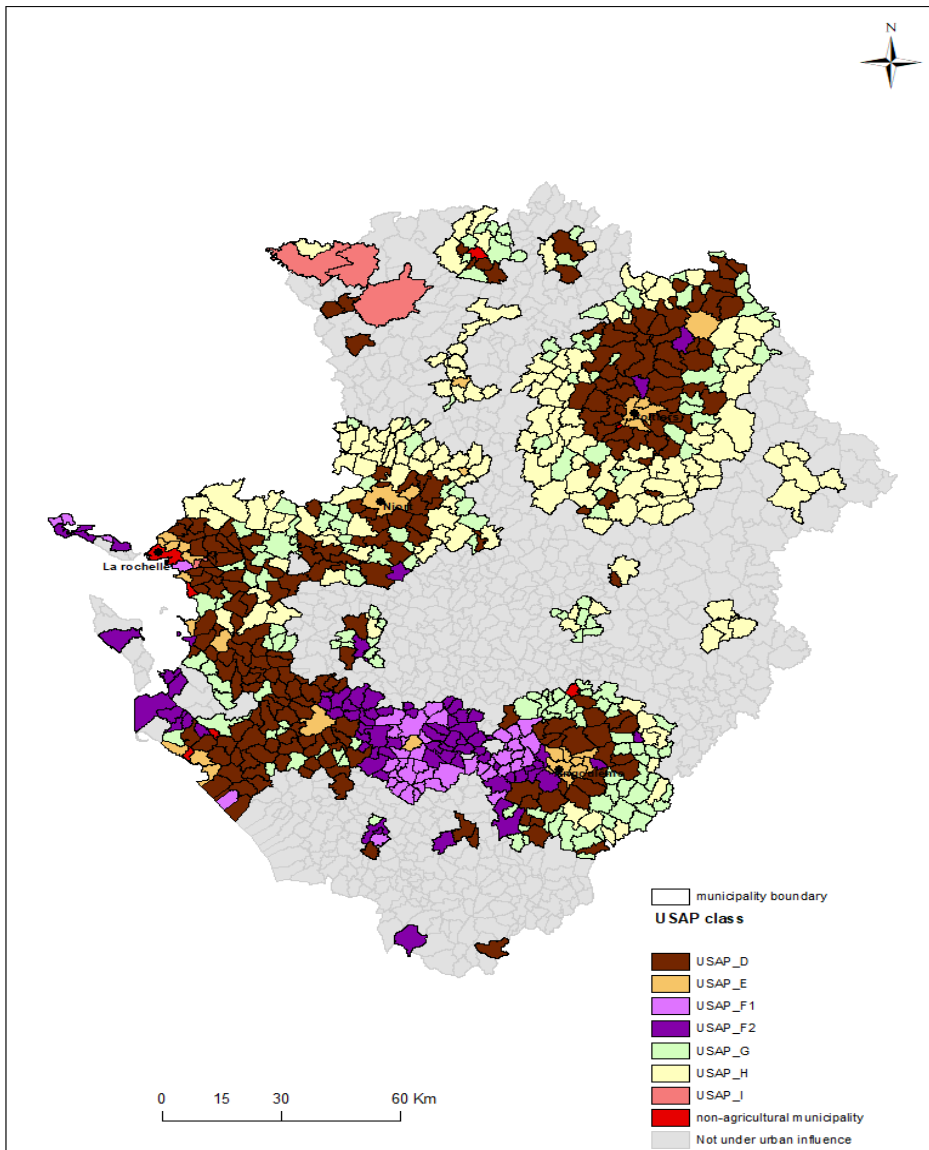

Figure 6: Geographic distribution of the USAPs by municipality - Poitou-Charentes region.

5. Discussion. Contributions supporting decisions in urban planning for food accessibility

Efforts to reconnect agriculture to the city inevitably raise the issue of the spatial efficiency of public action. The agricultural areas of a region or a country, even considering solely those under urban influence (INSEE, 2011), are too extensive for costly actions to be undertaken without identifying them from a spatial point of view. Therefore it is the agricultural areas most likely to respond to public action that need to be characterized and mapped; for example, it is not effective to attempt to transform monocrop farms that are very successful on the international market into small diversified structures targeting short marketing chains. Here, using statistical tools (PLS-PM model with latent variables) to evaluate the effect of characteristics not previously measured (the potential for connection to the city) on the basis of data available at public action scale (population, land use, agricultural prices, etc.), we show that it is possible to characterize and to map at regional level communities that have agricultural areas suitable for establishing or developing farms connected to the city. The classification of periurban farmland according to sensitivity to urban influence can support planning decisions aimed at fostering the development of food relocalization strategies, at two levels of public action: local (spatial planning, for instance) and regional (strategic planning). Our classification highlights areas where it may be socially desirable to manage trends in land-use patterns to support enhancement of agriculture and correlated food systems, and where public action is more likely to be efficient. For instance, in USAP-E type municipalities, institutional incentives (ex. guaranteed demand for public school food procurement) could promote the establishment of new farms on abandoned agricultural areas. In this sense, the proposed methodology contributes to the debate on food planning and sustainable food production (FAO et al., 2018; Gottero, 2019; Vidal, 2014; Viljoen and Wiskerke, 2012; Watts et al., 2005).

Strictly speaking, our results illustrate very intuitive spatial relationships between human activities and periurban landscapes. For example, demography has an influence on landscape elements in that the increase in urban populations leads to an extension of anthropized areas at the expense of natural agricultural ones (Laugier, 2012). Additionally, our results also reveal the structural complexity of these areas and allow us to prioritize the relationships between the factors that structure them (the five latent variables). This demonstrates the particular importance of the socio-economic structure of the farm:

- It strongly impacts the landscape structure and composition through the way in which farmers adapt to incentives from the city (food demand, competition for land, etc.) and thus modify the spatial signature of their farms at the community level (Shannon Index). For example, farms connected to the city may diversify their crops to meet the demands of urban populations or to respond to a public incentive (like the "territorial feeding project" (act number 2014-1170 called "loi d'avenir pour l'agriculture, l'alimentation et la forêt") or a public procurement experiment (as in Avignon city -see <http://foodshift2030.eu/>).
- It influences demography, to a small degree, through the residential preferences of urban households that value open agricultural areas close to the city (Cavailhès et al., 2009).
- However, it has little impact on landscape management and function. Since landscape management is primarily influenced by land prices, farmers' choices have little effect on land values: in this case, urban demand preferences are the major driver on this market (Geniaux, Ay and Napoléone, 2011). The landscape function takes account of historical continuities related to agriculture and is not directly influenced by how farm structures adapt to economic cycles at the time scale of our study.

Consequently, our methodology allows us to characterize the elements that could potentially increase the effectiveness of a public action designed to preserve periurban areas. Currently, some are aimed at preserving existing agricultural areas from the regulatory point of view (see French policy for the preservation of agricultural

land⁷), whereas others are aimed at supporting the food supply via short marketing chains (see the report of the working group “short marketing chains” of the French Ministry of Agriculture⁸). Our results show that in addition to the dynamics of land use, marketing networks or market prices, the socio-economic structuring of farms is an important action lever for the landscape, its management and its function. A support or incentive policy for the development of periurban agricultural production with potential for connection to the city should therefore focus on establishing a network of actions promoting the development of connected farms, not just on individual financial incentives or price support. This could, for example, be achieved through support for local physical infrastructures like silos, refrigerators, market places, offering producers the opportunity to choose between different options in terms of connecting to the city.

6. Conclusion

We sought to explore and characterize, at the municipal level, periurban farmland showing potential for connection to the city, with the aim of supporting regional level public decision-making concerning food supply and short marketing chains. By assessing the effects of manifest variables within the PLS-PM, we were able to distinguish between spatial units of periurban farmland (USAPs) under urban influence (USAPs D and E) and those that are minimally, or not at all, connected to urban areas (USAPs A, B, C and F) (Map 2). USAPs D and E are characterized by the presence of farms devoted to market garden crops and horticulture, production systems generally associated with the city. However, they are also characterized by a landscape heterogeneity and abandonment of agricultural land that bear witness to a situation of uncertainty. This could result in a sharp reduction in the areas’ number of farms, making it impossible to supply short urban marketing chains, develop local marketing systems, or even relocate farms selling their wares on local markets. The evolutionary path that each of these areas will follow (abandonment vs. revival) thus depends on political and economic frameworks that can reduce uncertainties. For example, if landowners anticipate the constructability of land without public regulation in a context of intensified urban development, they will refuse to make their plots available for cultivation and generate agricultural wastelands. As soon as a proactive public policy organizes the protection of agricultural areas, the level of uncertainty linked to how long the land can be cultivated is reduced, encouraging farmers to plant crops. In other words, the proposed methodology makes it possible to pinpoint those agricultural municipalities under urban influence where policies for short supply chains would be most effective. This should greatly contribute to planning decisions at regional scale.

It should also be pointed out that our methodology could be improved by changing the scales of analysis, in particular from a municipal scale to an infra-municipal scale capable of ensuring that it is appropriate for the diversity of agricultural practices in spatially-extensive municipalities (French municipalities are generally small). Refining the spatial scale of the study may also imply a shift of modeling techniques towards a more refined tool such as Structural Equation Modeling (SEM), which is more suitable for larger databases. However, even bearing this in mind, our work shows that periurban agriculture can be analyzed at the scale of a public action using relatively simple statistical modeling based on different, freely available, databases. This type of analysis requires an accurate prior understanding of the internal relationships between the factors that determine the evolution of a periurban agricultural system but that, *in fine*, can inform decisions on food management in cities from the point of view of urban development.

⁷ <https://agriculture.gouv.fr/paysage-la-preservation-du-foncier-agricole>

⁸ https://agriculture.gouv.fr/sites/minagri/files/documents/pdf/rapport_du_gt_circuits_courts0409.pdf

Acknowledgements

This work was funded by the National Institute of Agricultural Research's (INRA) pre-maturation program as part of the Agriville-USAP project in collaboration with the Land Use and Rural Settlement Corporation (SAFER). It was also supported by a public grant overseen by the French National Research Agency (ANR) as part of the « Investissements d'avenir » program (reference: ANR-10-EQPX-17 – Secure Data Access Centre - CASD).

References

- Arnal, C., 2013. Les circuits courts de proximité, un enjeu pour les politiques publiques à la périphérie des villes moyennes. Les circuits courts de proximité. Renouer les liens entre les territoires et la consommation alimentaire. Paris, France. hal-01075471.
<https://hal.archives-ouvertes.fr/hal-01075471>.
- Aubry, C., Kebir, L., 2013b. Shortening food supply chains: a means for maintaining agriculture close to urban areas? The case of the French metropolitan area of Paris. Food Policy 41, 85–93.
<http://dx.doi.org/10.1016/j.foodpol.2013.04.006>.
- Bagozzi, R. P., 1980. Causal Models in Marketing, New York: Wiley. 303 pp
<https://doi.org/10.1177/009207038000800316>.
- Bailey, A., Williams, N., Palmer, M., Geering, R., 2000. The farmer as service provider: the demand for agricultural commodities and equine services. Agric. Syst. 66, 191–204.
[http://dx.doi.org/10.1016/S0308-521X\(00\)00047-0](http://dx.doi.org/10.1016/S0308-521X(00)00047-0).
- Balambo, M.A, Baz.J., 2014. De l'intérêt de l'analyse des modèles des équations structurelles par la méthode PLS dans les recherches sur les relations inter organisationnelles: le cas des recherches en Logistique. 7ème Edition du colloque international LOGISTIQUE. hal-01503345., 9.
<https://hal.archives-ouvertes.fr/hal-01503345>
- Bauer, G., Roux J.M., 1977. La rurbanisation ou la ville éparpillée. In: Norois, n°94, Avril. pp.325-326;
https://www.persee.fr/doc/noroi_0029-182x_1977_num_94_1_3585_t1_0325_0000_2
- Bertrand, N., Rousier, N., 2004. L'agriculture périurbaine, une proximité ville agriculture à construire. Quatrième Journées de la Proximité, IDEP-LEST-GREQAM, Groupe de Recherche Dynamique de Proximité, Marseille, pp.17. halshs-00102574.
<https://halshs.archives-ouvertes.fr/halshs-00102574>
- Binz, A.C., Patelb, V., Wanzenried, G., 2014. A comparative study of CB-SEM and PLSSEM for theory development in family firm research. J. Fam. Bus. Strat. 5 (1), 116–128. DOI: 10.1016/j.jfbs.2013.12.002
<https://ideas.repec.org/a/eee/fambus/v5y2014i1p116-128.html>
- Bryant, C.R., Johnston T.R.R., 1992. Agriculture in the city's countryside. Londres, Royaume-Uni, Belhaven Press.
- Bryant, C.R., 1992. Farming at the urban fringe. Chapitre 10. In: Bowler, I.R. (Ed.), The Geography of Agriculture. Routledge, London & New York, pp. 275–304.
- Cavailhès, J., Wavresky, P., 2007. Les effets de la proximité de la ville sur les systèmes de production agricoles. Agreste Cahiers 2, 41-47.

- Cavailhès, J., T. Brossard, J.C., Foltête, M., Hilal, D., Joly, F.P., Tourneux, C., Tritz, P., Wavresky., 2009. GIS-Based Hedonic Pricing of Landscape. *Environmental and Resource Economics*, Vol. 44, Issue 4, pp 571–590.
<https://doi.org/10.1007/s10640-009-9302-8>.
- Crié D., 2005. De l’usage des modèles de mesures réflectifs ou formatifs dans les modèles d’équations structurelles, *Recherche et Applications Marketing*, 20, 2, 5-27.
<https://doi.org/10.1177%2F076737010502000201>
- Croutsche, J. J., 2009. *Analyse des données en Marketing, en Management et en Sciences Sociales: Conceptualisation et Applications*. Paris: Editions ESKA.
- Darly, S., Aubry, C., 2014. La demande en produits locaux de la restauration collective : quels liens avec l’offre de proximité dans une région d’agriculture industrielle ? Le cas de l’Ile-de-France. *Géocarrefour* 89 (1-2), 145–157.
<https://doi.org/10.4000/geocarrefour.9470>
- Diamantopoulos , A., Winklhofer, H., 2001. Index Construction with Formative Indicators: An Alternative to Scale Development. *Journal of Marketing Research*, 38(2), 269-277.
<https://doi.org/10.1509/jmkr.38.2.269.18845>
- Dijkstra,TK., Henseler,J., 2015a. Consistent and asymptotically normal PLS estimators for linear structural equations.*Comput.Stat.Data Anal.*81,10-23.
- Dijkstra,TK., Henseler,J., 2015b. Consistent partial least squares path modeling. *MIS Quart.*39,297-316.
- Donadieu, P., Fleury, A., 1997a. De l’agriculture périurbaine à l’agriculture urbaine. *Le courrier de l’environnement*, no 31.
<https://hal.archives-ouvertes.fr/hal-01204863>
- Drucker, C., Godard, C., Ehlinger S. and Grenier C., 1999. Validité et fiabilité de la recherche – in « Méthodes de recherche en management » – R.A. Thiétart (ed.) – Paris, Dunod – p 257-287.
- Duchemin, É., Wegmuller, F., Legault A.M., 2010. Agriculture urbaine: un outil multidimensionnel pour le développement des quartiers. *Vertigo*, 10(2)
<https://doi.org/10.4000/vertigo.10436>
- Duvernoy, I., Zambon, I., Sateriano, A., Salvati, L., 2018. Pictures from the other side of the fringe: Urban growth and peri-urban agriculture in a post-industrial city (Toulouse, France). *Journal of Rural Studies* 57:25-35.
<https://doi.org/10.1016/j.jrurstud.2017.10.007>
- Elgåker, H.E., 2012. The new equine sector and its influence on multifunctional land use in peri-urban areas. *GeoJournal* 77, 591–613.
<http://dx.doi.org/10.1007/s10708-010-9398-y>.
- Esposito-Vinzi, V., Trinchera,L., Amato, S., 2010. PLS Path Modeling: From Foundations to Recent Developments and Open Issues for Model Assessment and Improvement, in: *Handbook of Partial Least Squares: Concepts, Methods and Applications*, Heidelberg (Germany) : Springer, 47-82.
http://link.springer.com/10.1007/978-3-540-32827-8_3
- Esposito-Vinzi, V., Trinchera, L., Squillacciotti, S.,Tenenhaus, M., 2008. REBUS-PLS: A response-based

procedure for detecting unit segments in PLS path modeling, *Applied Stochastic Models in Business and Industry*, 24 (5), 439-458.

<https://doi.org/10.1002/asmb.728>

FAO, F. and A.O. of the U.N., RUAF, F., WLU, W.L.U., 2018. City Region Food System. Tools / examples. City Region Food System Toolkit Assessing and planning sustainable city region food systems. FAO, RUAF Fondation, Wilfrid Laurier University.

<http://www.fao.org/3/I9255EN/i9255en.pdf>

Fernandes, V., 2012. En quoi l'approche PLS est-elle une méthode à (re)-découvrir pour les chercheurs en management? *M@n@gement*, 15,1, 101-123.

<https://www.cairn.info/revue-management-2012-1-page-102.htm>

Freund, Y., H. S. Seung, E. Shamir, et N. Tishby., 1997. Selective sampling using the queryby committee algorithm. *Machine Learning* 28(2-3), 133-168.

<https://doi.org/10.1023/A:1007330508534>

Gallent, N., D. Shaw, 2007. Spatial planning, area action plans and the rural nexturban fringe. *Journal of Environmental Planning and Management*. 50, 617-638.

<https://doi.org/10.1080/09640560701475188>

Geniaux, G., Ay, J.-S., Napoléone, C., 2011. A spatial hedonic approach on land use change anticipations. *J. Reg. Sci.* 51, 967-986.

<https://doi.org/10.1111/j.1467-9787.2011.00721.x>

Gottero, E. (Ed.), 2019. *Agrourbanism: Tools for Governance and Planning of Agrarian Landscape*, GeoJournal Library. Springer International Publishing, Cham.

<https://doi.org/10.1007/978-3-319-95576-6>

Groot, J.C.J., Rossing, W.A.H., Tichit, M., Turpin, N., Jellema, A., Baudry, J., Verburg, P.H., Doyen, L., van de Ven, G.W.J., 2009. On the contribution of modelling to multifunctional agriculture: Learning from comparisons. *Journal of Environmental Management* 90, 147-160.

<https://doi.org/10.1016/j.jenvman.2008.11.030>

Hair J.F., Ringle C.M., Sarstedt M., 2011. PLS-SEM: Indeed a Silver Bullet, *Journal of Marketing Theory and Practice*, 19, 2, 139-151.

<https://doi.org/10.2753/MTP1069-6679190202>

Hair, J.F., Hult, G.T.M., Ringle, C., Sarstedt, M., 2014. *A Primer on Partial Least Squares Structural Equation Modeling*. Sage Publications Inc.

<https://doi.org/10.1016/j.lrp.2013.01.002>.

Helming, K., Pérez-Soba, M., 2011. Landscape scenarios and multifunctionality: making land use impact assessment operational. *Ecology and Society* 16, 50.

<http://www.ecologyandsociety.org/vol16/iss1/art50/>

Henseler, J., Dijkstra, T.K., Sarstedt, M., Ringle, C.M., Diamantopoulos, A., Straub, D.W., Ketchen, D.J., Hair, J.F., Hult, G.T.M., Calantone, R.J., 2014. Common Beliefs and Reality About PLS: Comments on Rönkkö and Evermann (2013). *Organizational Research Methods* 17, 182-209.

<https://doi.org/10.1177/1094428114526928>

- Ilbery, B.W., 1991. Farm diversification as an adjustment strategy on the urban fringe of the West Midlands. *J. Rural Stud.* 7, 207–218.
[https://doi.org/10.1016/0743-0167\(91\)90085-7](https://doi.org/10.1016/0743-0167(91)90085-7)
- INSEE, 2011. Le nouveau zonage en aires urbaines de 2010 Poursuite de la périurbanisation et croissance des grandes aires urbaines. INSEE PREMIERE N° 1375.
<https://www.insee.fr/fr/statistiques/1281046>.
- Jakobowicz, E., 2007. Contributions aux modèles d'équations structurelles à variables latentes. *Mathématiques [math]*. Conservatoire national des arts et métiers – CNAM.
<https://tel.archives-ouvertes.fr/tel-00207990>
- Jarrige, F., 2004. Les mutations d'une agriculture méditerranéenne face à la croissance urbaine. Dynamiques et enjeux autour de Montpellier. *Cahiers Agricultures* 13, 64-74.
<http://revues.cirad.fr/index.php/cahiers-agricultures/article/view/30423>
- Jarvis, C., MacKenzie, S., Podsakoff, P.A., 2003. Critical review of construct indicators and measurement model misspecification in marketing research. *Journal of Consumer Research* 2003; 30(2):199–218.
<https://doi.org/10.1086/376806>
- Jouve, A.M., Napoléone, C., 2003. Stratégies des agriculteurs et réorganisations spatiales sous contrainte de la périurbanité : étude du pays d'Aix-en-Provence. In: Elloumi, M., Jouve, A.-M. (Eds.), *Bouleversements Fonciers En Méditerranée. Des Agricultures Sous Le Choc de L'urbanisation et Des Privatisations*, Paris, pp. 143–172
http://www.iamm.ciheam.org/ress_doc/opac_css/index.php?lvl=notice_display&id=13098
- Kizos, T., Kristensen, L.S., 2011. The “good farmer”: studies of farm management practices and landscape change. Editorial of special issue. *Geografisk Tidsskrift-Danish J. Geogr.* 111, 105–106.
<http://dx.doi.org/10.1080/00167223.2011.10669526>.
- Kline, R.B., 2005. *Principle and practice of structural equation modelling* – New York – Guilford press.
<https://doi.org/10.1177/1049731509336986>
- Kumar, G., Tuluri, A.F., Tchounwou, P.B., 2015. Development of PLS–path model for understanding the role of precursors on ground level ozone concentration in Gulfport, Mississippi, USA. *Atmos. Pollut. Res.* 6 (3), 389–397.
- Lacroux, A., 2005. *l'analyse des modeles de relations structurelles par la methode pls: une approche emergente dans la recherche quantitative en grh*, 6 p.
<https://docplayer.fr/11826702>
- Lahmouz, K., Duyck, J.P., 2008. « Implication organisationnelle et stress professionnel, rôle de l'auto-efficacité », *Communication au 29ème congrès de l'AGRH, Dakar (Sénégal)*.
- Lange, A., Piorr, A., Siebert, R., Zasada, I., 2013. Spatial differentiation of farm diversification: how rural attractiveness and vicinity to cities determine farm households' response to the CAP. *Land Use Policy*.
<https://doi.org/10.1016/j.landusepol.2012.02.010>
- Lardon, S. (Ed.), 2012. *Géoagronomie, paysage et projets de territoire. Sur les traces de Jean-Pierre Deffontaines, Indisciplines*. Editions Quae - NSS Dialogues, Paris.

- Laugier, L., 2012. L'étalement urbain en France. Synthèse documentaire, 14p.
- Lees, C., Derioz, P., 1994. Le jardin de la France au péril de la ville : place et évolution de l'activité agricole dans le Grand Avignon. *Bull. Ass. Géog. Fr.* 1994-2, 170-180.
- McIntosh, C.N., Edwards, J.R., Antonakis, J., 2014. Reflections on Partial Least Squares Path Modeling. *Organizational Research Methods* 17, 210–251. <https://doi.org/10.1177/1094428114529165>
- Majdi, N., Boiché, A., Traunspurger, W., Lecerf, A., 2014. Predator effects on a detritus based food web are primarily mediated by non-trophic interactions. *J. Anim. Ecol.* 83 (4), 953–962.
<https://doi.org/10.1111/1365-2656.12189>
- Marraccini, E., Lardon, S., Sabbatini, T., 2017. Les configurations spatiales agri-urbaines - Pour intégrer l'agriculture dans l'aménagement des territoires urbains. *Spatial Analysis and GEomatics 2017*, INSA de Rouen, Rouen, France. hal-01649748.
<https://hal.archives-ouvertes.fr/hal-01649748>
- Metzger, J-L., Lardon, S., Le Ber F., 2006. Comparaison d'organisations spatiales agricoles. Le système ROSA. *Revue Internationale de Géomatique*, vol. 16, p. 195-210.
<https://hal.archives-ouvertes.fr/hal-00087228>
- Morgan, K., Sonnino, R., 2010. The urban foodscape: world cities and the new food equation. *Camb. J. Reg. Econ. Soc.* 3, 209–224.
<http://dx.doi.org/10.1093/cjres/rsq007>.
- Nibigira, R., 1991. L'agriculture de montagne en France. Note de Synthèse. Université Claude Bernard Lyon I, 13 p.
- OECD, O. for E.C. and D., 2017. Land-use planning systems in the OECD: country fact sheets.
- Pérès, S., 2007. La vigne et la ville: forme urbaine et usage des sols. Doctoral thesis. Université Montesquieu-Bordeaux IV, pp. 387.
<https://tel.archives-ouvertes.fr/tel-00448670>
- Primdahl, J., 1999. Agricultural landscapes as places of production and for living in owner's versus producer's decision making and the implications for planning. *Landscape and Urban Plan.* 46, 143–150.
- Chemnitz, C., 2019. Agriculture Atlas. Facts and figures on EU farming policy. Heinrich Böll Foundation, Friends of the Earth Europe, BirdLife Europe & Central Asia, Berlin (Germany), Brussels (Belgium).
- Reimer, M., Getimis, P., Blotevogel, H.H. (Eds.), 2014. Spatial planning systems and practices in Europe: a comparative perspective on continuity and changes. Routledge, New York, NY.
<https://doi.org/10.4324/9781315852577>
- Rizzo, D., Marraccini, E., Lardon, S., Rapey, H., Debolini, M., Benoît, M., Thenail, C., 2013. Farming systems designing landscapes: land management units at the interface between agronomy and geography. *Geografisk Tidsskrift-Danish Journal of Geography* 113, 71–86.
<https://doi.org/10.1080/00167223.2013.849391>
- Rönkkö, M., McIntosh, C.N., Antonakis, J., Edwards, J.R., 2016. Partial least squares path modeling: Time for some serious second thoughts. *Journal of Operations Management* 47–48, 9–27.
<https://doi.org/10.1016/j.jom.2016.05.002>

- Rönkkö, M., Evermann, J., 2013. A Critical Examination of Common Beliefs About Partial Least Squares Path Modeling. *Organizational Research Methods* 16, 425–448. <https://doi.org/10.1177/1094428112474693>
- Roussel, P., Durrieu, F., Campoy, E., El Akremi, A., 2002. *Méthodes d'équations structurelles : recherche et applications en gestion*– Paris, Economica coll. Gestion.
- Sanches, F., Fernandes, Ferreira, Cortes, Pacheco., 2018. A partial least squares - Path modeling analysis for the understanding of biodiversity loss in rural and urban watersheds in Portugal. *Science of the Total Environment* 626 (2018) 1069–1085.
- Sanz Sanz, E., 2016. *Planification urbaine et agriculture. Méthodologie systémique de caractérisation de l'agriculture périurbaine à partir d'une recherche empirique en France et en Espagne (Thèse pour l'obtention du titre de docteur en géographie (UAM) et en études urbaines (EHESS))*. EHESS/UAM.
- Sanz Sanz, E., Martinetti, D., Napoléone, C., 2018. Operational modelling of peri-urban farmland for public action in Mediterranean context. *Land Use Policy* 75, 757–771. <https://doi.org/10.1016/j.landusepol.2018.04.003>
- Sanz Sanz, E., Napoléone, C., Hubert, B., 2017. A systemic methodology to characterize peri-urban agriculture for a better integration of agricultural stakes in urban planning. *L'espace géographique* 46, 174–190. DOI : [10.3917/eg.462.0174](https://doi.org/10.3917/eg.462.0174)
- Sanz Sanz, E., Napoléone, C., Hubert, B., Mata, R., Giorgis, S., 2017. Repenser la planification urbaine à partir des espaces agricoles. *Revue d'Économie Régionale & Urbaine* 511–536. <https://doi.org/10.3917/reru.173.0511>
- Sanz Sanz, E., Napoléone, C., Hubert, B., 2016. Peri-urban farmland characterisation: a methodological proposal for urban planning, in: Roggema, R. (Ed.), *Sustainable Urban Agriculture and Food Planning*. Routledge, Oxon, UK, pp. 73–89. ISBN: 978-1-138-18308-7 (AP)
- Schaldach, R., Priess, J.A., 2008. Integrated models of the land system: a review of modelling approaches on the regional to global scale. *Living Reviews in Landscape Research* 2. <http://dx.doi.org/10.12942/lrlr-2008-1>
- Sharpley, R., Vass, A., 2006. Tourism, farming and diversification: an attitudinal study. *Tourism Manage.* 27, 1040–1052. <http://dx.doi.org/10.1016/j.tourman.2005.10.025>.
- Soulard, C.-T., 2014. Les agricultures nomades, une caractéristique du périurbain. *Pour* 224, 151–158. <https://doi.org/10.3917/pour.224.0151>
- Soulard, C.-T., Perrin, C., Valette, E. (Eds.), 2017. *Toward Sustainable Relations Between Agriculture and the City, Urban Agriculture*. Springer International Publishing, Cham. <https://doi.org/10.1007/978-3-319-71037-2>
- Sosik, J., Kahai, S., & Piovoso, M., 2009. Silver Bullet or Voodoo Statistics? A Primer for Using the Partial Least Squares Data Analytic Technique in Group and Organization Research. *Group & Organization Management*, 34(1), 5-36. <https://doi.org/10.1177/1059601108329198>
- Tenenhaus, M., 1999. L'approche PLS. *Revue de Statistique Appliquée*, 47(2), 5-40. http://www.numdam.org/item/RSA_1999__47_2_5_0/

- Tenenhaus, M., Esposito-Vinzi, V., 2005. PLS Regression, PLS Path Modeling and Generalized Procrustean Analysis: A Combined Approach for Multiblock Analysis, *Journal of Chemometrics*, 19, 145-153.
<https://doi.org/10.1002/cem.917>
- Termorshuizen, J.W., Opdam, P., 2009. Landscape services as a bridge between landscape ecology and sustainable development. *Landscape Ecology* 24, 1037–1052.
<https://doi.org/10.1007/s10980-008-9314-8>.
- Thapa, R.B., Murayama, Y., 2008. Land evaluation for peri-urban agriculture using analytical hierarchical process and geographic information system techniques: A case study of Hanoi. *Land Use Policy* 25, 225–239.
<https://doi.org/10.1016/j.landusepol.2007.06.004>.
- Tolron, J.J., 2001. L'agriculture périurbaine : paradigme et paradoxes d'une péri-agriculture. Illustration en région méditerranéenne. *Ingénieries* 28, 65-73.
<https://hal.archives-ouvertes.fr/hal-00464627>
- Vaudois, J., 1994. Les zones maraîchères péri-urbaines: espaces résiduels ou nouvelles formes d'intégration aux stratégies urbaines. *Bull.Soc.Géo.Franc.*, 71(2), 123-134.
https://www.persee.fr/doc/bagf_0004-5322_1994_num_71_2_1726
- Vaudois, J., 1995. Les dynamiques agricoles dans les zones périurbaines : formes et éléments d'interprétation. L'agriculture dans l'espace périurbain : des anciennes aux nouvelles fonctions. Actes de l'atelier de recherches. Bergerie Nationale de Rambouillet. 10 et 11 mai 20-29.
- Vidal, R., 2014. L'agriurbanisme en 40 pages, Lire comprendre maintenant. éditions Uppr, (livre électronique).
- Viljoen, A., Wiskerke, J.S.C. (Eds.), 2012. Sustainable food planning evolving theory and practice. Wageningen Academic Publishers, The Netherlands.
<https://research.brighton.ac.uk/en/publications/sustainable-food-planning-evolving-theory-and-practice>
- Watts, D., Ilbery, B.W., Maye, D., 2005. Making reconnections in agro-food geography: alternative systems of food provision. *Progress in Human Geography* 29, 22–40.
<https://doi.org/10.1191/0309132505ph526oa>.
- Wilson, G.A., 2007. Multifunctional agriculture: a transition theory perspective. CABI, Cambridge, MA 385p.
- Wold, H., 1974. Causal flows with latent variables : partings of the ways in the light of NIPALS modeling. *Eur.EcoN.Rev.* 5, 67-86.
[https://doi.org/10.1016/0014-2921\(74\)90008-7](https://doi.org/10.1016/0014-2921(74)90008-7)
- Wold, H., 1982. Soft Modeling: Intermediate between Traditional Model Building and Data Analysis, *Mathematical Statistics*, 6, 333-346.
- Yang, Z., Cai, J., Sliuzas, R., 2010. Agro-tourism enterprises as a form of multi-functional urban agriculture for peri-urban development in China. *Habitat Int.* 34, 374–385.
<http://dx.doi.org/10.1016/j.habitatint.2009.11.002>.
- Zasada, I., 2011. Multifunctional peri-urban agriculture—a review of societal demands and the provision of goods and services by farming. *Land Use Policy* 28, 639–648.

<http://dx.doi.org/10.1016/j.landusepol.2011.01.008>.

Zasada, I., Berges, R., Hilgendorf, J., Piorr, A., 2013a. Horsekeeping and the peri-urban development in the Berlin metropolitan region. *J. Land Use Sci.* 8, 199–214.

<http://dx.doi.org/10.1080/1747423X.2011.628706>.

Zasada, I., Loibl, W., Köstl, M., Piorr, A., 2013b. Agriculture under human influence: a spatial analysis of farming systems and Land use in European rural-urban-regions. *Eur. Countryside* 5, 71–88.
<http://dx.doi.org/10.2478/euco-2013-0005>.

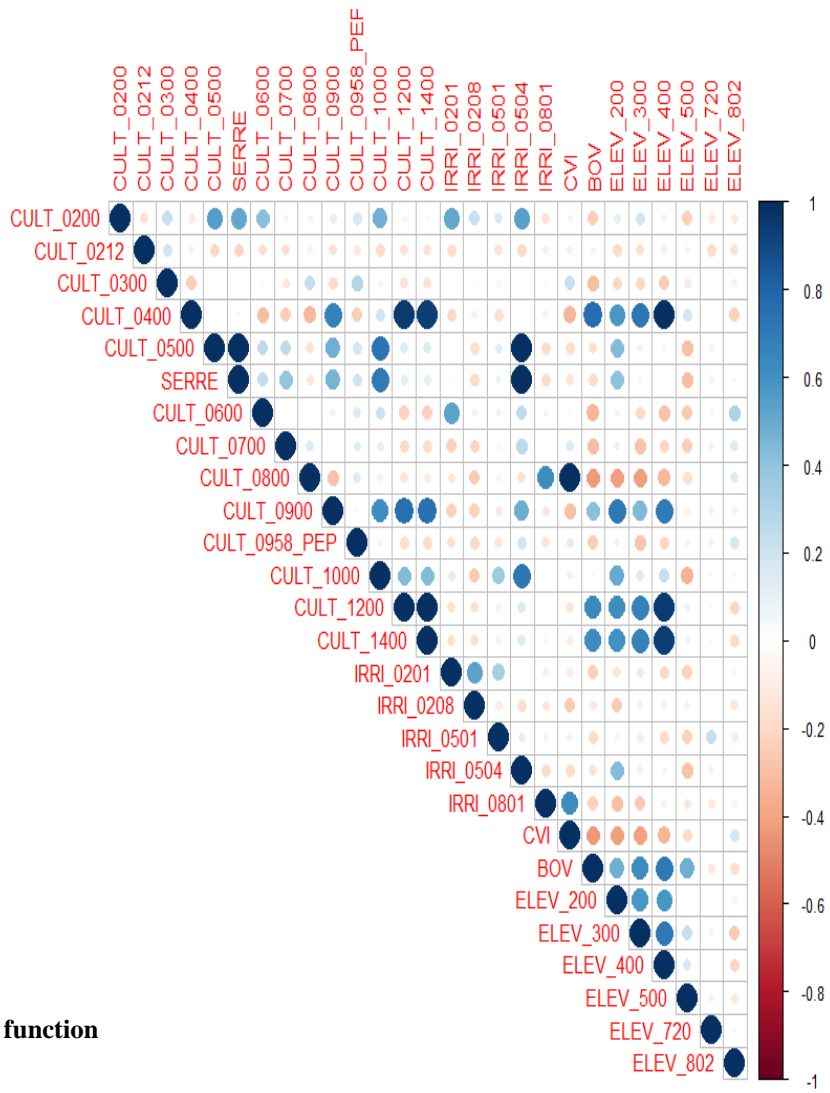

Landscape function

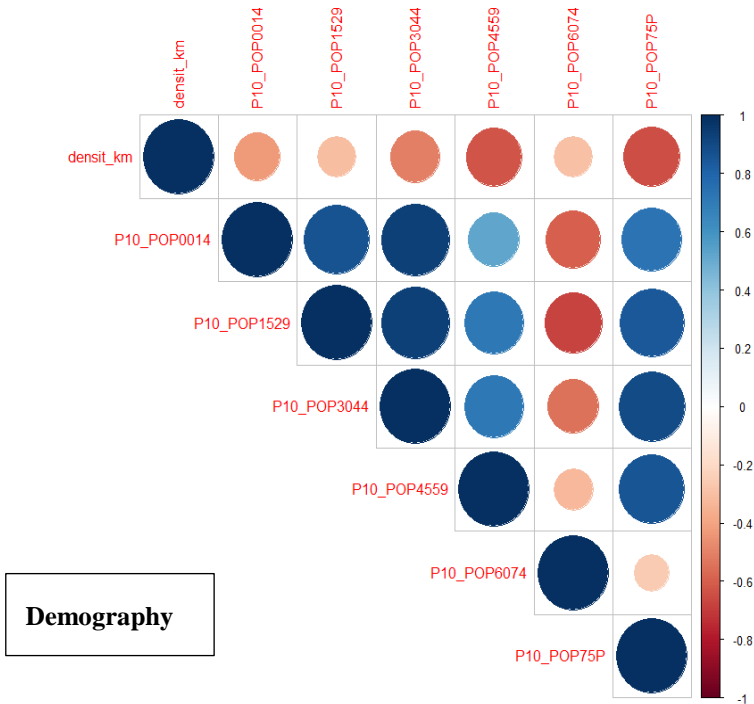
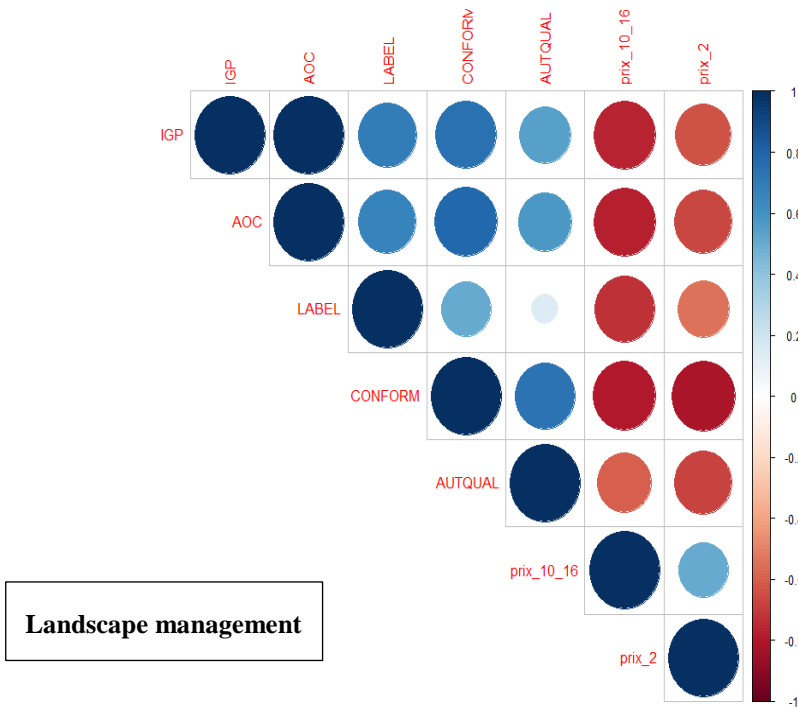

Appendix B. Appendix List of manifest variables used in the study

LV	mv	Description
Socio-economic structure of the farm	CIRCOULIFIL	Percentage of No short chain marketing
	CIRCOUPDIR	Percentage of Direct sales to the consumer on his/her own behalf
	CIRCOUPAUT	Percentage of Sales via another short marketing chain on his/her own behalf
	CIRCOUADIR	Percentage of Direct sales to the consumer through a legal entity other than that of the farm
	CIRCOUAAUT	Percentage of Sales via another short marketing chain through a legal entity other than that of the farm
	CIRCOUCA	Percentage of Share of the turnover per product
	BIO	Number of Organic farms
	DIVERSIFICATION	Numbers of Diversified farms
	FORMAGEN_0	Farmers with no general academic qualification
	FORMAGEN_1	Farmers with a general academic qualification
	FORMAGRI_0	Farmers with no agricultural qualification
	FORMAGRI_1	Farmers with an agricultural qualification
	OTEX_1500	Number of Farms specialized in cereal crops and oilseed and protein crops
	OTEX_1600	Number of Farms specialized in other field crops
	OTEX_2800	Number of Farms specialized in vegetable crops and mushrooms
	OTEX_2900	Number of Farms specialized in flower crops and diverse horticulture
	OTEX_3500	Number of Farms specialized in winegrowing
	OTEX_3900	Number of Farms specialized in fruit and other permanent crops
	OTEX_4500	Number of Cattle farms specialized in dairy products
	OTEX_4600	Number of Cattle farms specialized in breeding and meat
	OTEX_4813	Number of Specialized goat and sheep farms
	OTEX_4840	Number of Farms specialized in goat, sheep and other herbivorous animals
	OTEX_6184	Number of Polyculture and mixed livestock farms
	M	Number of male farmers
	F	Number of Female Farmers (F)
	TERRE_201	UAA – Land leased from third parties (ares)
	TERRE_202	UAA – Land leased from associates (ares)
	TERRE_203	Owner-occupied (ares)
	TERRE_204	Sharecropping (ares)
	TERRE_205	Other forms of tenure (ares)

	TERRE_301	Total permanent crop area in a heated greenhouse or heated high tunnel (m ²) - Fruits and vegetables need to be added for total greenhouse surface area
	TERRE_302	Total permanent crop area in an unheated greenhouse or unheated tunnel (m ²)
	TERRE_401	Drained area (ares)
	TERRE_501	Type of irrigation – irrigated surface area - sprinkling (ares)
	TERRE_502	Micro-irrigation (drip, etc.) (ares)
	UTATOT	Total annual work units
	UTATCEX	Annual work units (UTA) of the farm manager
	UTATCOEX	Annual work units (UTA) of co-farmers (excluding the manager)
	UTATCEXCOE	Annual work units (UTA) of managers and co-farmers
	UTATCNCO	Annual work units of spouse of manager or co-farmers, not a co-farmer him/herself
	UTATAAF	Annual work units (UTA) of other family members
	UTATFTO	Annual work units (UTA) provided by family labor
	UTATFSA	Annual work units (UTA) provided by family labor, farm employee
	UTATFFN	Annual work units (UTA) provided by family labor, female
	UTATprm	Annual work units (UTA) provided by permanent employees not family members
	UTATSAL	Annual work units (UTA) provided by employees, family members or not (UTATSAL=UTATprm+UTATFSA)
	UTACuma	Annual work units (UTA) provided on the farm by CUMA employees
	UTAeta	Annual work units (UTA) provided on the farm by employees of farm contractors
	UTATsai	Annual work units (UTA) provided by non-permanent labor (seasonal, occasional, apprentices, not including farm support services)
	nombre_exploit	Number of farms
Demography	densit_km	Population density (in hab/km ²)
	P10_POP0014	Percentage of population in 2010 between 0 and 14 years old
	P10_POP1529	Percentage of population in 2010 between 15 and 29 years old
	P10_POP3044	Percentage of population in 2010 between 30 and 44 years old
	P10_POP4559	Percentage of population in 2010 between 45 and 59 years old
	P10_POP6074	Percentage of Population in 2010 between 60 and 74 years old
	P10_POP75P	Percentage of population in 2010 over 75 years old
	MED14	Median standard of living (euros/month)

Landscape structure	L_TOT_R	Total length of roads (kilometers)
	std_AL	Standard deviation: altitudes (meters)
	min_AL	Minimum altitude (meters)
	max_AL	Maximum altitude (meters)
	median_AL	Median altitude (meters)
	mean_AL	Average altitude (meters)
	std_P	Standard deviation: Slope (meters)
	max_P	Maximum slope (percentage)
	median_P	Median slope
	mean_P	Average slope
	pz11	Percentage of land use category: crops
	pz13	Percentage of land use category: vineyards
	pz12	Percentage of land use category: forest
	pz14	Percentage of land use category: natural formation
	pz15	Percentage of land use category: urban
shdi	Shannon Index	
Landscape management	IGP	Percentage of Agricultural products with Protected Geographical Indication (IGP)
	AOC	Percentage of Agricultural products with Registered Designation of Origin (AOC)
	LABEL	Percentage of Agricultural products with a quality index label
	CONFORM	Percentage of Products with a quality conformity label
	AUTQUAL	Percentage of Products with a quality label
	Prix_2	Maximum price (market value of land and pasture, 1991-2014) in thousands of euros/ha
	prix_10_16	Average price of land transactions (2010 and 2016) in euros
	CULT_0200	Total oilseed/protein crops (ares)
	CULT_0212	Total fiber plants (ares)
	CULT_0300	Total industrial plants (ares)
	CULT_0400	Total forage and constantly cultivated areas (ares)
	CULT_0500	Total dried and fresh vegetables, strawberries and melons (ares)
	SERRE	Fresh vegetables, strawberries and melons in a greenhouse or tunnel
	CULT_0600	Total potatoes (ares)
	CULT_0700	Total ornamental plants and flowers (ares)
	CULT_0800	Total vineyards (ares)
	CULT_0900	Total permanent corps (ares)
	CULT_0958_PEP	Nursery - ornamental, fruit, forest (ares)
	CULT_1000	Total fallow land (ares)

Landscape function	CULT_1200	UAA (ares)
	CULT_1400	Total area (ares)
	IRRI_0201	Total irrigated oilseed crops (season 2009-2010) (ares)
	IRRI_0208	Total irrigated protein crops (season 2009-2010) (ares)
	IRRI_0501	Total irrigated dried vegetables (season 2009-2010) (ares)
	IRRI_0504	Total irrigated fresh vegetables, strawberries and melons (season 2009-2010) (ares)
	IRRI_0801	Total irrigated wine-grapevines (season 2009-2010) (ares)
	CVI	Wine production of grapes harvested in 2010 ha
	BOV	Total cows
	ELEV_200	Total equidae
	ELEV_300	Total goats
	ELEV_400	Total sheep
	ELEV_500	Total pigs
	ELEV_720	Total farming capacity – hens and pullets
	ELEV_802	Apiculture - quantity of honey produced (kg)

Appendix C. Definition of USAP classes in the Poitou-Charentes region

USAP_G: Municipalities in this class are distinguished by lowly fragmented landscapes (low Shannon Index) on minimal altitudes of around 60 m. They have low population density and not much farmland, as shown by the small number of farmers in the area (an average of 12 per municipality). The median standard of living is lower than the average (2,100 euros) and the price of farmland is low. Although agricultural activity is very limited, what exists is oriented towards cereal crops and cattle farming. It is therefore an area with a weak connection to the city.

USAP_D: This class consists of lowly urbanized municipalities (less than 10% of the area) with lowly fragmented landscapes (low Shannon Index). It is also characterized by its small number of farmers and UAAs in which the farms are diversified, with cereal crops, market garden crops, vineyards and cattle farming. Some products have AOCs. The standard of living in the municipalities is above the average (2,000 euros) and certain farm products are marketed in short chains (market garden crops, cattle), whereas cereal crops are marketed in long chains. It is therefore an area with potential for connection to the city through development of short marketing chains with high local demand for local products.

USAP_F1: This class includes lowly urbanized areas with low population densities. The landscape is not very fragmented and the main agricultural activity is winegrowing, with some arboriculture. The vineyards in these municipalities have a heritage value and are classified as AOC Cognac. They also have a quality index label. Even close to cities, it can be assumed that these areas have an internal stability that is inherent to the profitability of winegrowing and, therefore there is not much potential to transform existing farms into systems focused on local markets. Cognac is primarily marketed in long chains by intermediaries. This area is not connected to the city.

USAP_H: Lowly fragmented landscapes located in sparsely populated municipalities (a density of 25 inhab/km²), with a median standard of living corresponding to the average (2,000 euros). Areas in the community earmarked for agriculture are limited (few farmers, around 20 per municipality), but the price of farmland is extremely variable. Agriculture is diversified: cattle, sheep and pig farming, arboricultural products, cereals. It is therefore an area with high potential for connection to the city.

USAP_F2: More sparsely populated and more fragmented than class 3, the municipalities in this class are moderately urbanized (28% of the area), with a standard of living above the average (2,500 euros). The useful agricultural area (UAA) is low and the average price of farmland is dictated by the value of the vineyards, classified as AOC but without a quality index label. The small number of farmers is divided between cereal crops and vineyards. Land pressure is such that there is wide variation in farmland prices. This characteristic is linked to the dynamics of the cities, influencing real estate and leading to an increase in the price of available farmland. It is therefore an area with a strong connection to the city through a short marketing chain for agricultural products.

USAP_E: Highly fragmented landscape and very urbanized, with high population density (750 inhab/km²), The standard of living is very high (> 2,500 euros) in the municipalities in this class. Urban development in this area has led to a loss of farmland (low UAA) and a small number of farmers (approximately 10 per municipality), resulting in a rise in land prices (the highest of all the USAP classes). Agriculture is oriented towards the production of cereal and market garden crops. It is therefore an area with a strong connection to the city through a short marketing chain for agricultural products.

USAP_I: This class encompasses lowly urbanized municipalities (less than 10% of the area) with lowly fragmented landscapes (low Shannon Index). The standard of living is below the average (less than 2,000 euros) and the population age is distributed between 15-30 and 45-60 years of age. Moreover, the useful agricultural area (UAA) of these municipalities is the largest of all of the USAP classes and they therefore have the greatest number of farmers (an average of 170 per municipality). However, the price of available farmland is low. Farms are diversified but mainly focused on cattle, sheep and pig farming. Market garden crops are also cultivated to a lesser degree. Livestock products are marketed within short chains. It is therefore an area with high potential for connection to the city.

Appendix D. Dendrogram of the hierarchal cluster analysis of the correlations of latent variables