



HAL
open science

Characterization of the gene content of *Coxiella burnetii* from different line ages in Europe

Aminah A. Keliet, Karim Sidi-Boumedine, Elsa Jourdain, Richard Thiéry,
Elodie Rousset, Xavier Bailly

► To cite this version:

Aminah A. Keliet, Karim Sidi-Boumedine, Elsa Jourdain, Richard Thiéry, Elodie Rousset, et al..
Characterization of the gene content of *Coxiella burnetii* from different line ages in Europe. Journées
d'Animation Scientifique du Département Santé Animale, Oct 2022, Anglet, France. . hal-03845604

HAL Id: hal-03845604

<https://hal.inrae.fr/hal-03845604>

Submitted on 9 Nov 2022

HAL is a multi-disciplinary open access archive for the deposit and dissemination of scientific research documents, whether they are published or not. The documents may come from teaching and research institutions in France or abroad, or from public or private research centers.

L'archive ouverte pluridisciplinaire **HAL**, est destinée au dépôt et à la diffusion de documents scientifiques de niveau recherche, publiés ou non, émanant des établissements d'enseignement et de recherche français ou étrangers, des laboratoires publics ou privés.



Distributed under a Creative Commons Attribution - NonCommercial - NoDerivatives 4.0
International License



Aminah Keliet¹, Karim Sidi-Boumedine², Elsa Jourdain¹, Richard Thiéry², Elodie Rousset² and Xavier Bailly¹

¹ Université Clermont Auvergne, INRA, VetAgro Sup, UMR EPIA Epidémiologie des maladies animales et zoonotiques, 63122, Saint-Genès-Champagnelle, France
² Anses (French Agency for Food, Environmental, and Occupational Health and Safety), Laboratory of Sophia Antipolis, Animal Q Fever Unit, Sophia Antipolis, France.

Corresponding Author: Aminah KELIET - aminah.keliet@inrae.fr - Route de Theix, 63540 Saint-Genès-Champagnelle

Context and objectives

Coxiella burnetii is the bacterium responsible for Q fever in humans. It causes fevers, headache, endocarditis, obstetrical complications, hepatitis, pneumonia, endovascular infections. *C. burnetii*, whose main reservoirs are ruminants, is resistant to heat, UV radiation and conventional disinfectants. In these ruminants, it is excreted mainly through the vagina, through the faeces and through the milk. It is thus found in dust, which is the main route of contamination in humans and ruminants.

In Europe, host specificity has been demonstrated [4]. We hypothesize that differences in host spectrum could have a genetic basis.

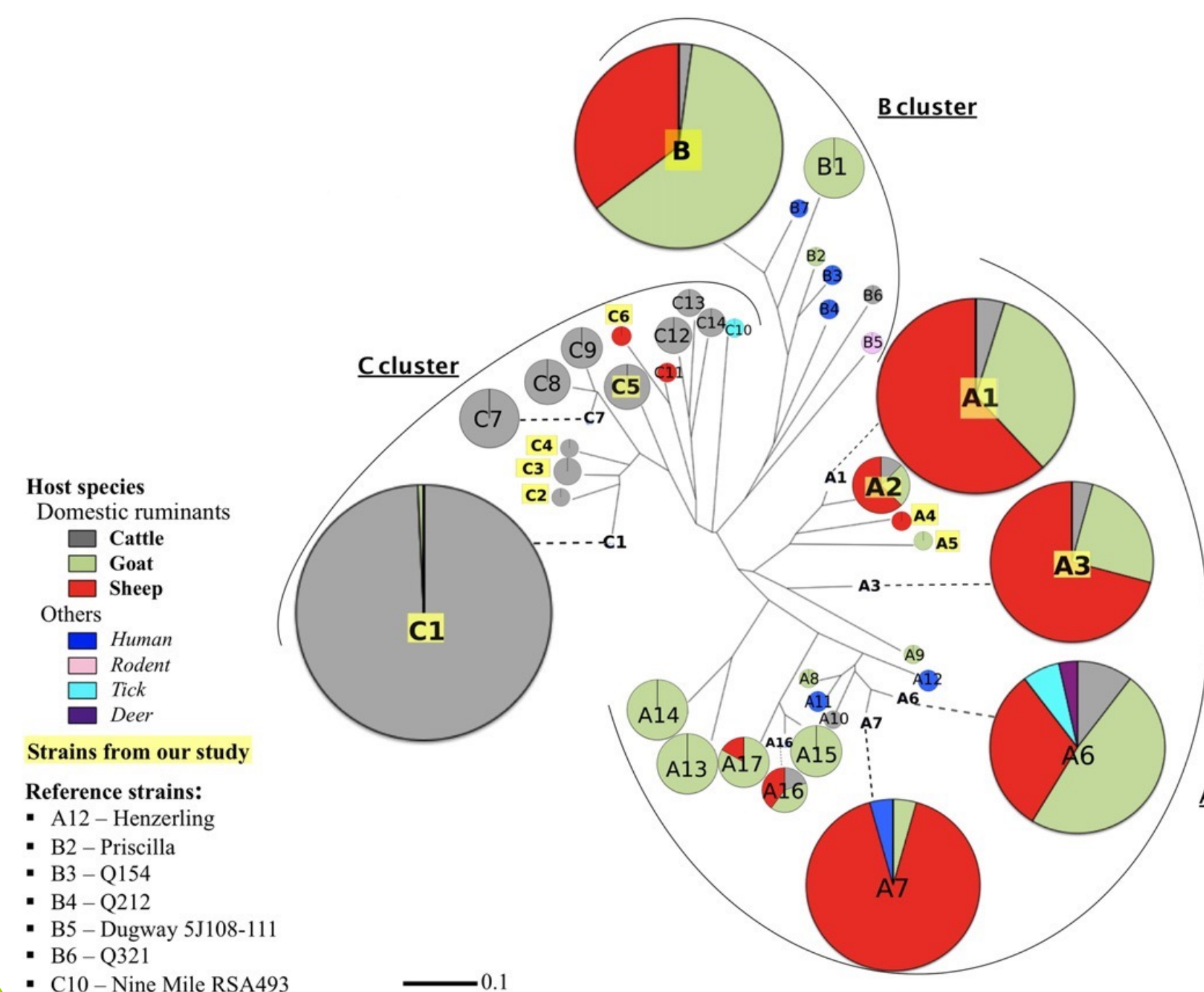

The aim of the study is therefore to understand the evolution of *C. burnetii* genomic diversity, by identifying and analyzing the specific genes of the main lineages and by describing the dynamics which lead to the distribution of the genes.

Methods

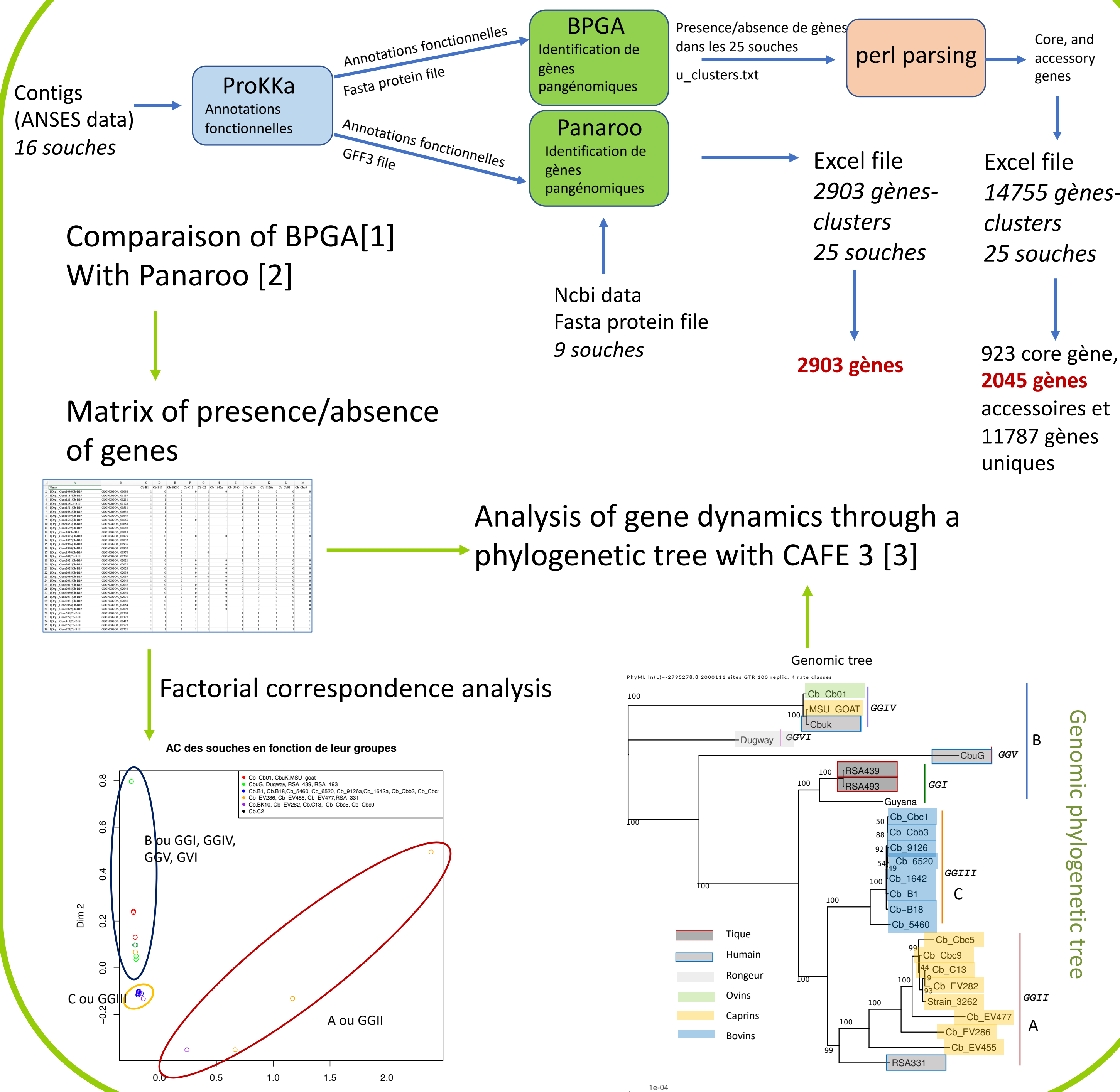

Results

Comparison of BPGA with Panaroo

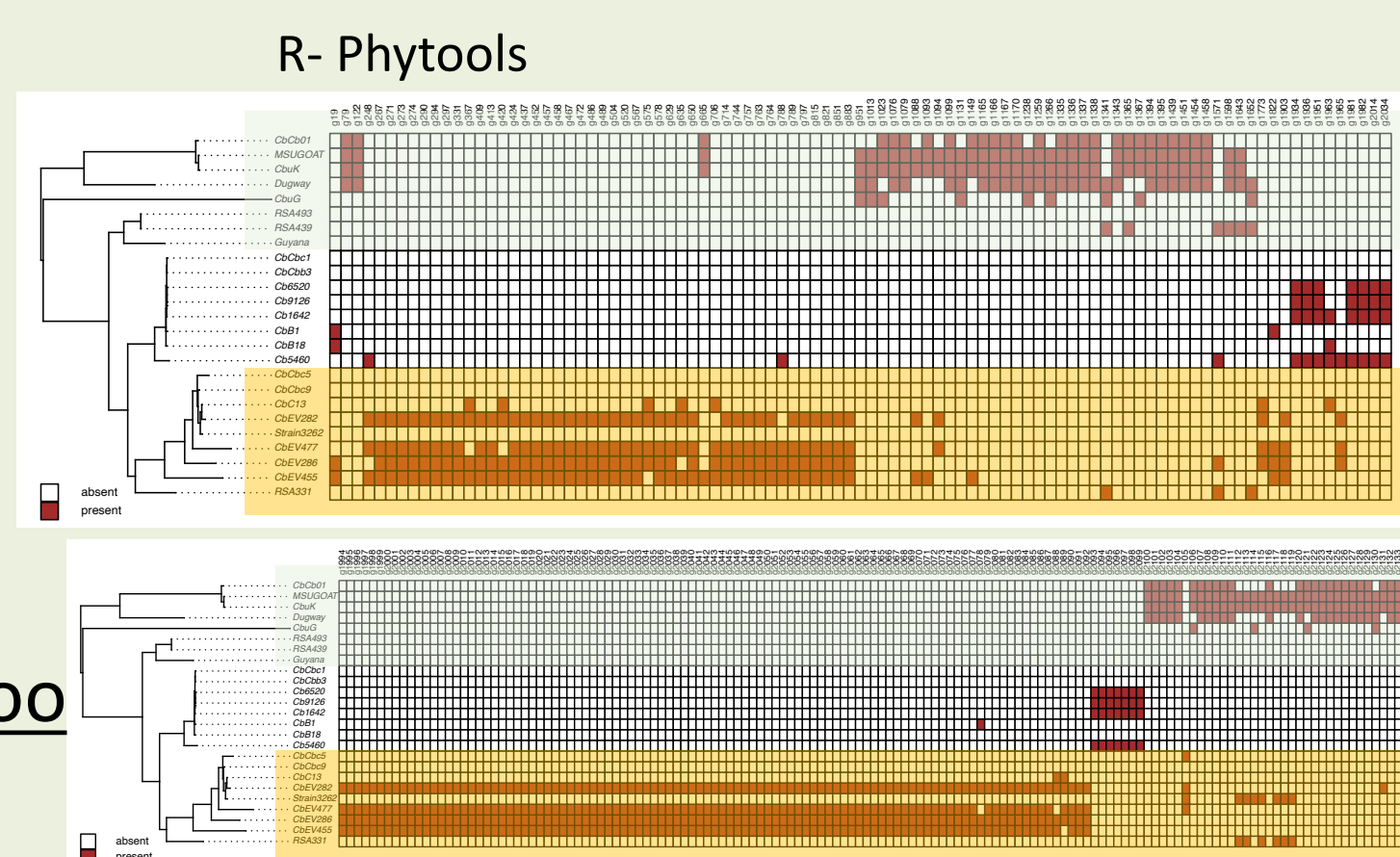
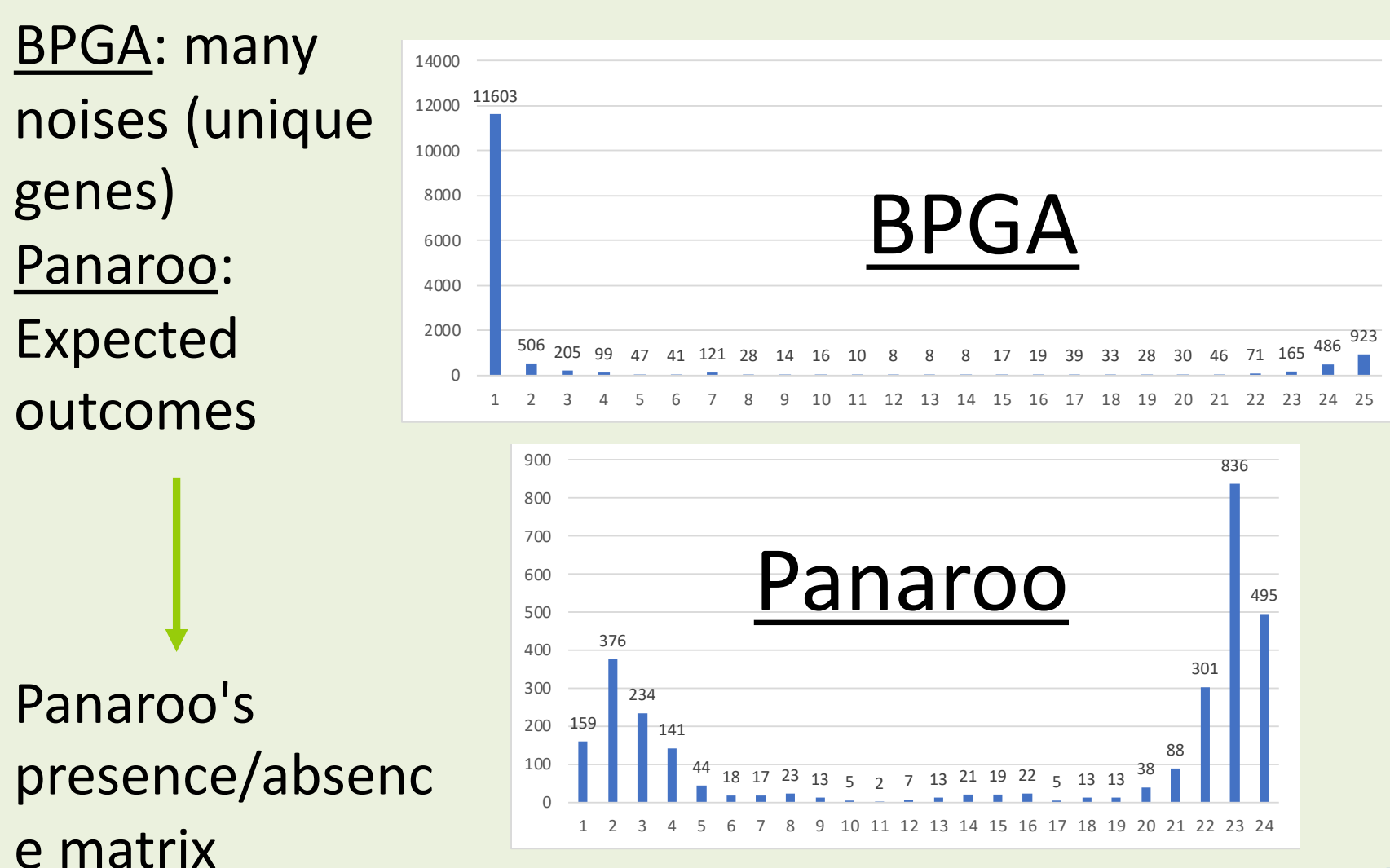

CAFE 3

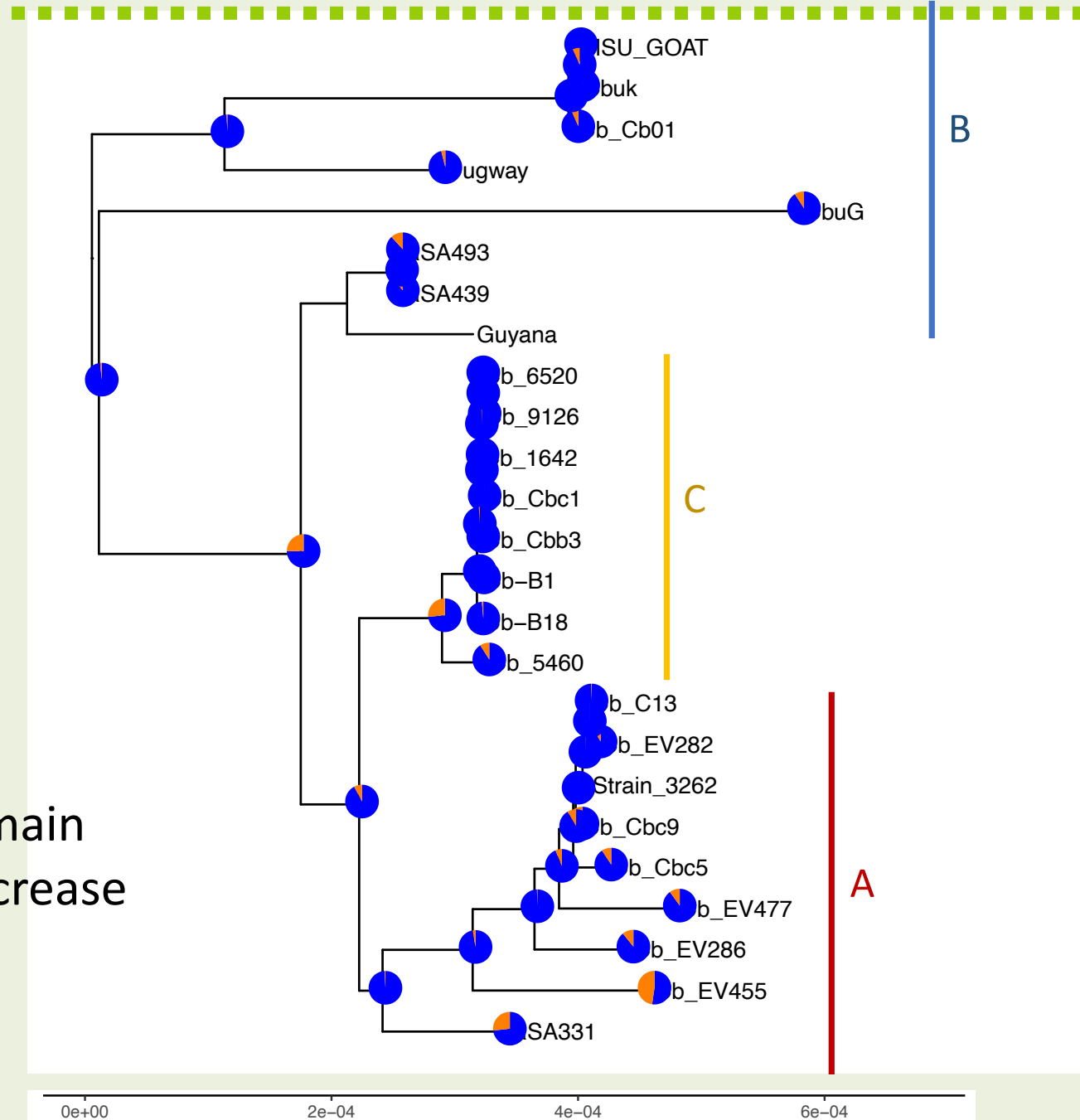

- group C gene content is highly homogenous.
- Throughout evolution, there were two main period of gene loss that influenced the genomic composition of *C. burnetii*: one that impacted lineages A and C and a related group including american isolates, and another impacting lineage C only.

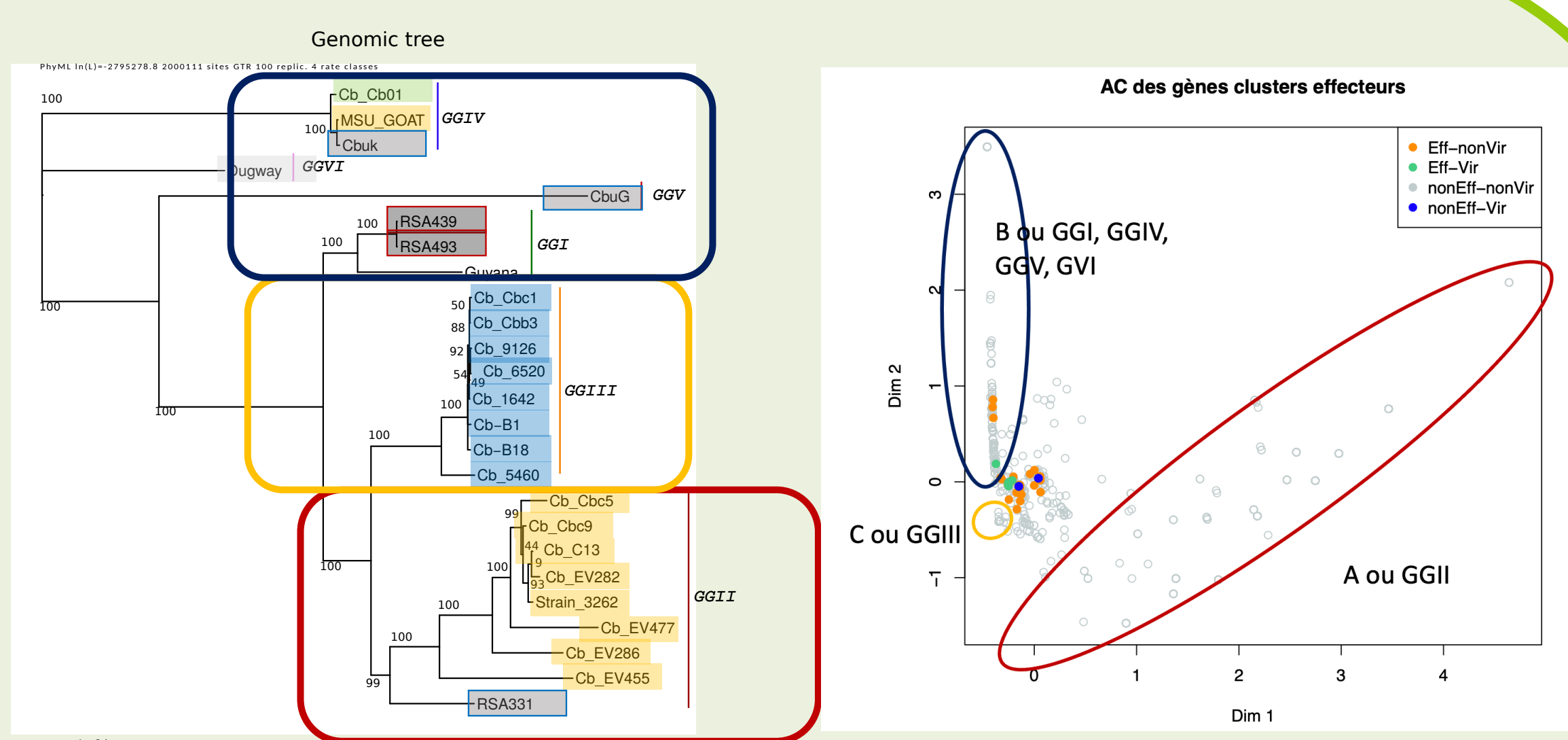

We clearly find our groups, A, B and C [4]

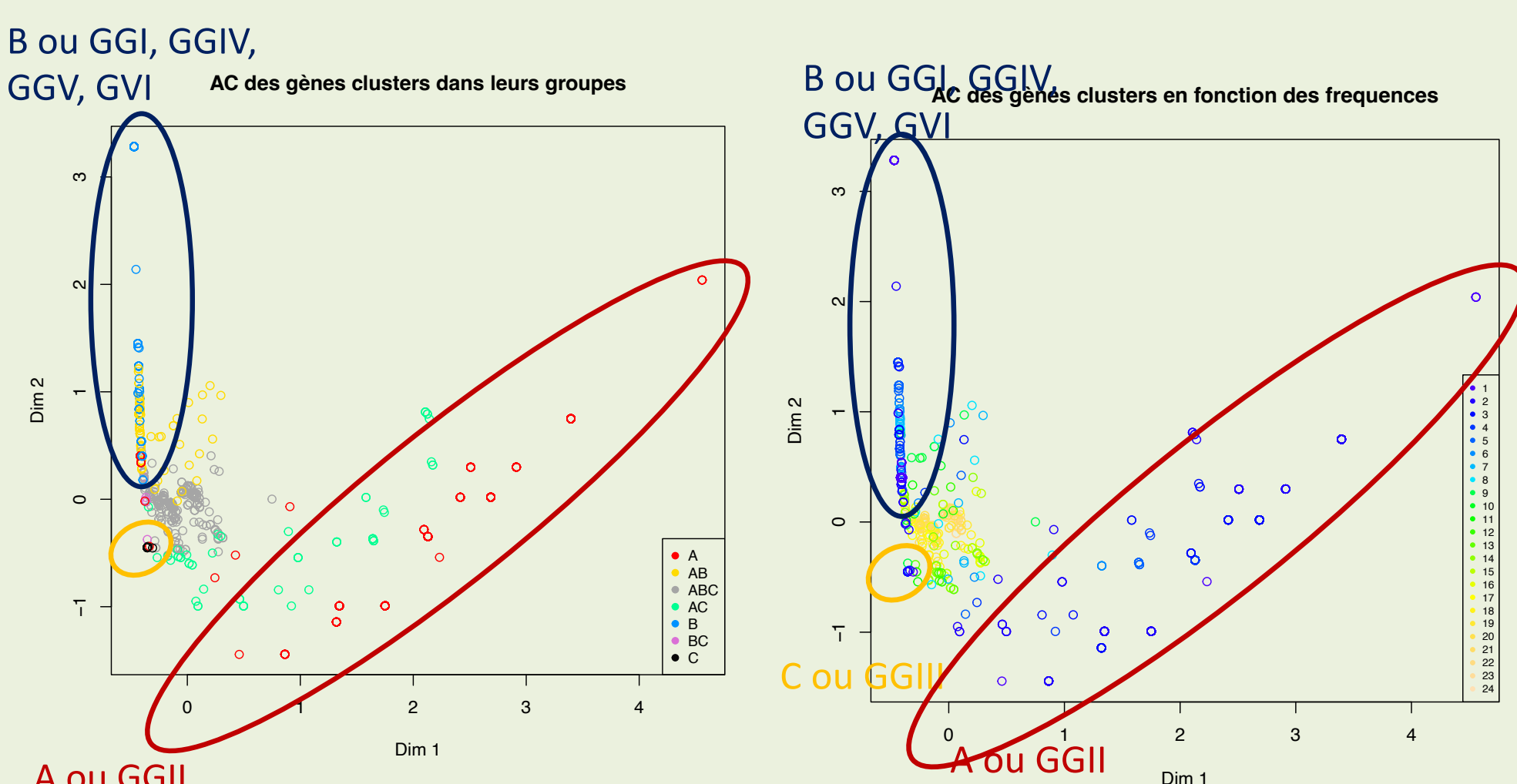

- ✓ Group C genes are also very homogeneous but present in most strains.
- ✓ Those of the A lineage are delineated and present in very few strains.
- ✓ Group B genes are also well delineated.

Conclusion

Some genes are very specific to lineages and constitute a first set of candidate for host specificity.

Also, a gene dynamic is at the origin of gene losses on the internal nodes of the tree (nodes at the origin of large groups), influencing an absence of genes in the lineages.

Perspectives

Further analyzes are needed to clearly identify the host-specific polymorphisms.

The analysis of synonymous and non-synonymous substitution rates in *C. burnetii* strains could give complementary information in the impact of selective pressures associated with host-range in *C. burnetii*.

Acknowledgments

We thank Julien Thézé for his pertinent remarks and questions

References

[1] Chaudhari, N. M. and al. BPGA- an ultra-fast pan-genome analysis pipeline. Sci. Rep. 6, 24373; doi: 10.1038/srep24373 (2016).
[2] Tonkin-Hill G, MacAlasdair N and al. 2020. Producing polished prokaryotic pangenomes with the Panaroo pipeline. Genome Biol 21:180.
[3] Han MV, Thomas GW, Lugo-Martinez J, Hahn MW. Estimating gene gain and loss rates in the presence of error in genome assembly and annotation using CAFE 3. Mol Biol Evol. 2013 Aug;30(8):1987-97. doi: 10.1093/molbev/mst100. Epub 2013 May 24. PMID: 23709260.
[4] Joulie A and al.; Animal diagnostic laboratories consortium, Leblond A, Rousset E, Jourdain E. Molecular epidemiology of *Coxiella burnetii* in French livestock reveals the existence of three main genotype clusters and suggests species-specific associations as well as regional stability. Infect Genet Evol. 2017 Mar;48:142-149. doi: 10.1016/j.meegid.2016.12.015. Epub 2016 Dec 20. PMID: 28007602.



anses