



HAL
open science

Rheology of acid cheese during its drainage

Marie-Hélène Famelart, I. Mtibaa, Florence Rousseau, Romain Richoux, Lydie Aubert-Frogerais

► **To cite this version:**

Marie-Hélène Famelart, I. Mtibaa, Florence Rousseau, Romain Richoux, Lydie Aubert-Frogerais. Rheology of acid cheese during its drainage. The XIXth Congress on Rheology (ICR), <https://www.erasmus.gr/microsites/1221/committees>, Jul 2023, Athènes, Greece. hal-04194808

HAL Id: hal-04194808

<https://hal.inrae.fr/hal-04194808v1>

Submitted on 4 Sep 2023

HAL is a multi-disciplinary open access archive for the deposit and dissemination of scientific research documents, whether they are published or not. The documents may come from teaching and research institutions in France or abroad, or from public or private research centers.

L'archive ouverte pluridisciplinaire **HAL**, est destinée au dépôt et à la diffusion de documents scientifiques de niveau recherche, publiés ou non, émanant des établissements d'enseignement et de recherche français ou étrangers, des laboratoires publics ou privés.



Distributed under a Creative Commons Attribution - NonCommercial - NoDerivatives 4.0 International License



Rheology of acid cheese during its drainage

MH. Famelart^a, I. Mtibaa^a, F. Rousseau^a, R. Richoux^b, L. Frogerais^b



^aSTLO, UMR 1253, INRAE, L'Institut Agro Rennes-Angers, Rennes, France



^bACTALIA, L'Institut Agro Rennes-Angers, Rennes, France



Presentation:

MH. Famelart, INRAE,
Dairy scientist



*Islem Mtibaa, Dairy Engineer on
fixed-term contract*



*Florence Rousseau, INRAE, Dairy
Engineer*



Romain Richoux, Actalia, Dairy engineer



Lydie Frogerais, Actalia, Dairy engineer

This project is managed by:

- ❖ Actalia, France (The French agri-food technical center in the dairy sector)

<https://www.actalia.eu/>

in collaboration with:

- ❖ STLO unit (INRAE)

https://www6.rennes.inrae.fr/stlo_eng/

- ❖ OPAALE unit (INRAE)

<https://opaale.rennes.hub.inrae.fr/>

It is funded by:

- ❖ CNIEL (the French inter-professional organisation) <https://www.filiere-laitiere.fr/fr/les-organisations/cniel>

- ❖ INRAE (National Research Institute for Agriculture, Food and Environment)

<https://www.inrae.fr/>

Context

Acid/lactic/fresh cheeses:

- Fromage frais,
 - Petit Suisse,
 - Cream cheese,
 - Cottage cheese,
 - Quarg...
-
- ❖ Low enzyme concentrations (enzymes: rennet, chymosin...) ,
 - ❖ Acidification by lactic acid bacteria to pH around 4.5,
 - ❖ Stirring the gel, then separation/draining:
 - centrifugal separation,
 - bag or filter,
 - molds,
 - ultrafiltration,
 - ❖ No ripening.

Context

A very schematic view of milk gelation

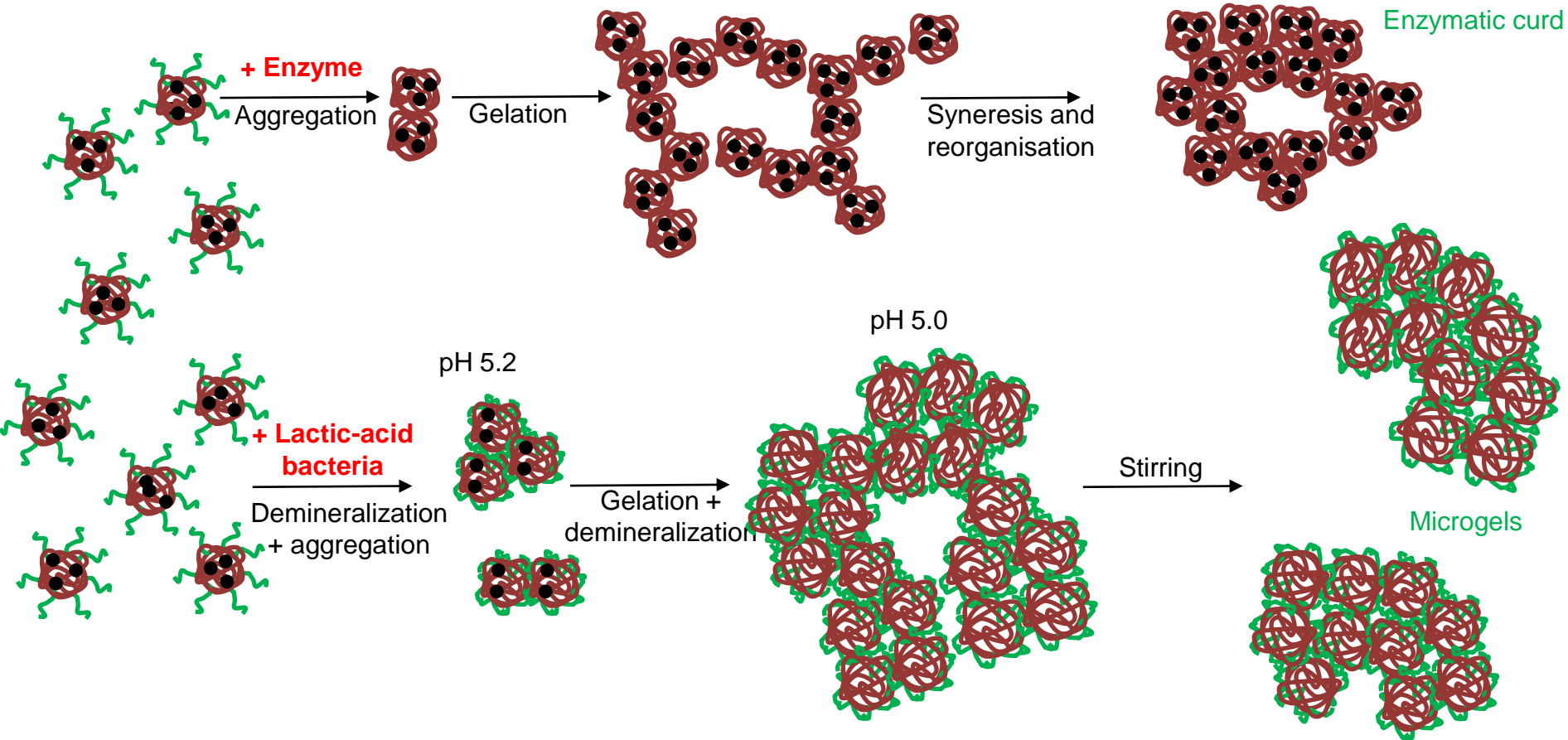
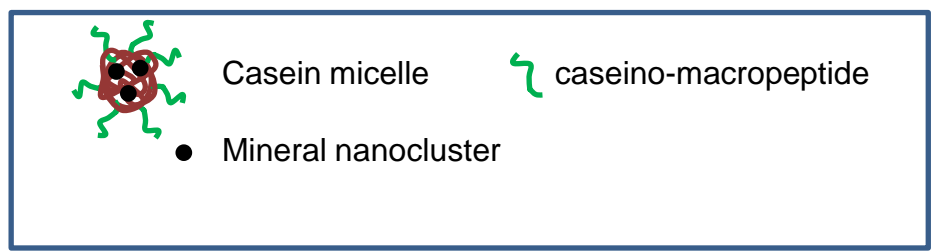

Context

Acid/lactic/fresh cheeses account for a large proportion of the market of dairy products (Grand View Research, Inc.)

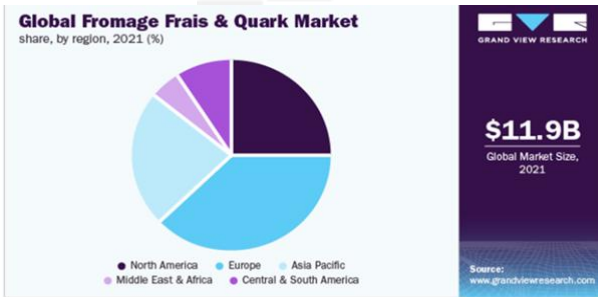

A great deal of studies on:

- Set-style and stirred yogurts (Clark et al., 2019; Lee & Lucey, 2010; Lucey, 2017; Gilbert & Turgeon, 2021).
- Enzymatic gelation and draining of rennet-type cheeses (Fagan et al. 2017, Fox et al., 2017; Gunasekaran et al., 2002)

Very few data available on the draining of acid curds and on their rheological behaviour during and after draining.

Dairy industrials need to understand/control/predict their draining and the properties of acid cheeses with the aim to optimize the process and the quality of final products.

Objectives

- ✓ Testing methods to study the properties of acid curds during draining,
- ✓ Studying rheological properties of acid cheeses during and after their draining.

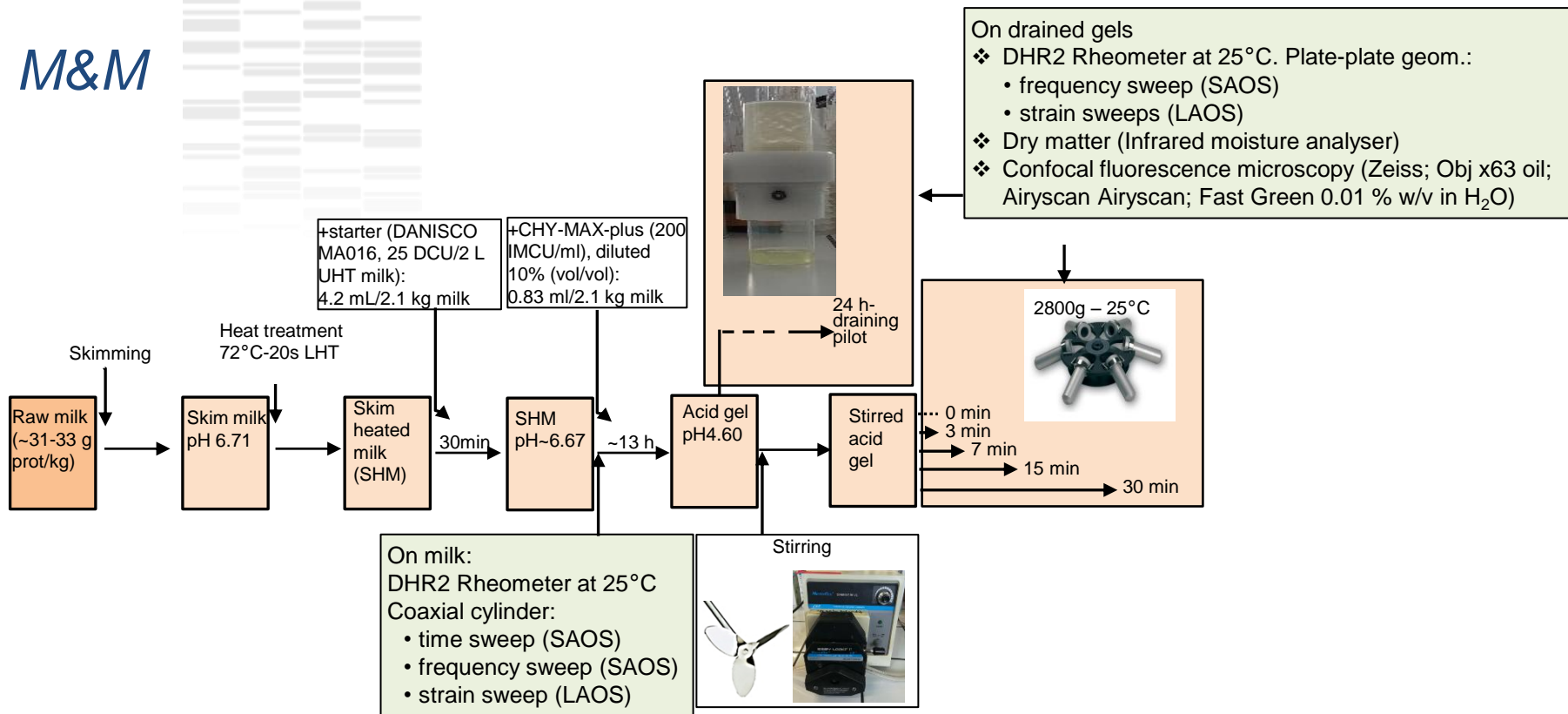
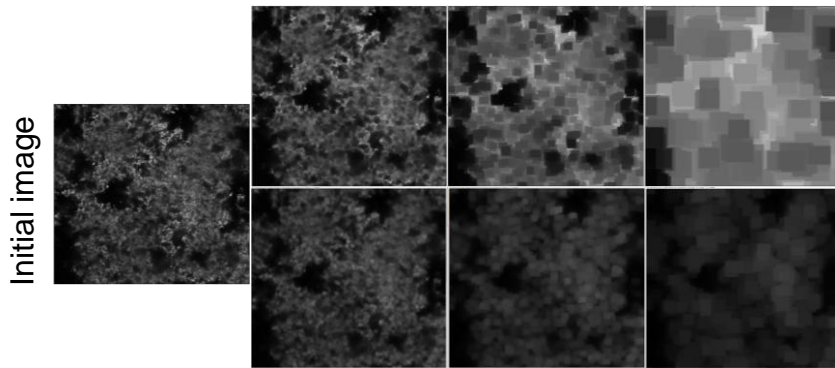
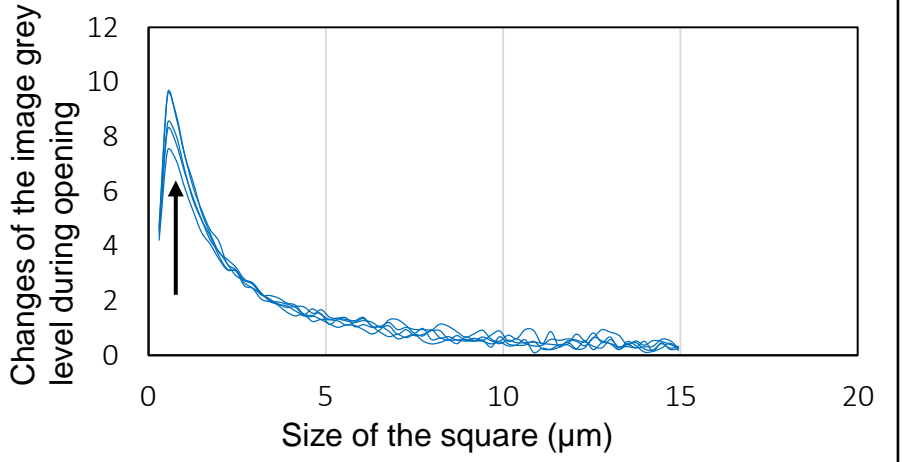
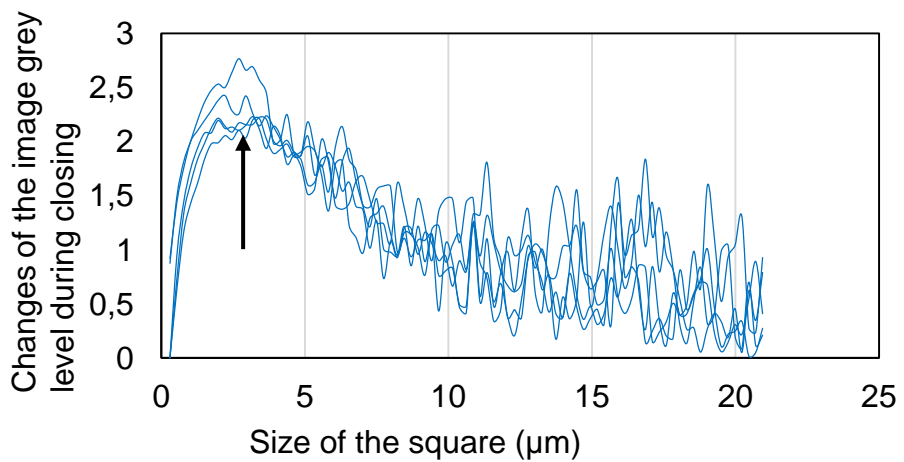
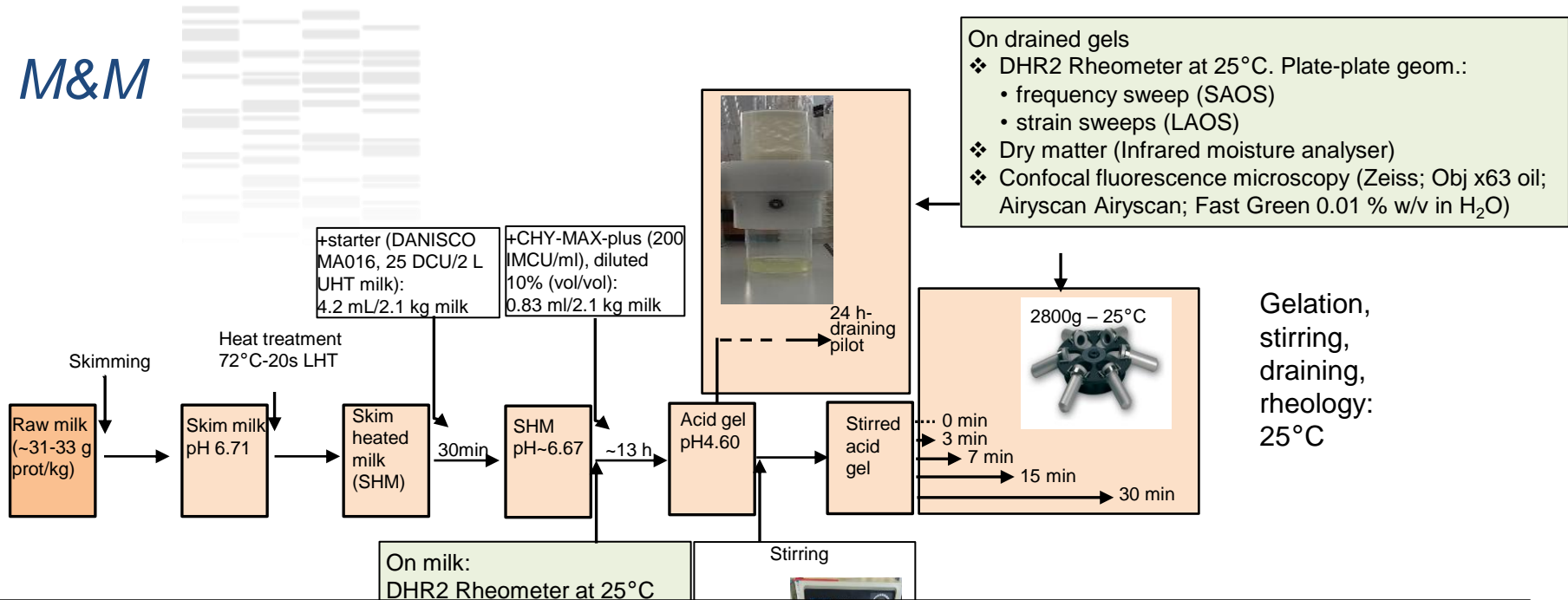

Image analysis by granulo-morphology (Greyscale granulometry plugin, ImageJ, D. Legland)



Closing = dilation (removes black pixels) + erosion (increases black pixels) with squares of increasing size = it removes black objects (i.e.pores)

Opening = erosion + dilation = it removes white objects (i.e. the network)



When changes in grey intensity of the image are maximum, the size of the square is the most frequent mean size of the pores/network.

Results

Kinetics of gelation

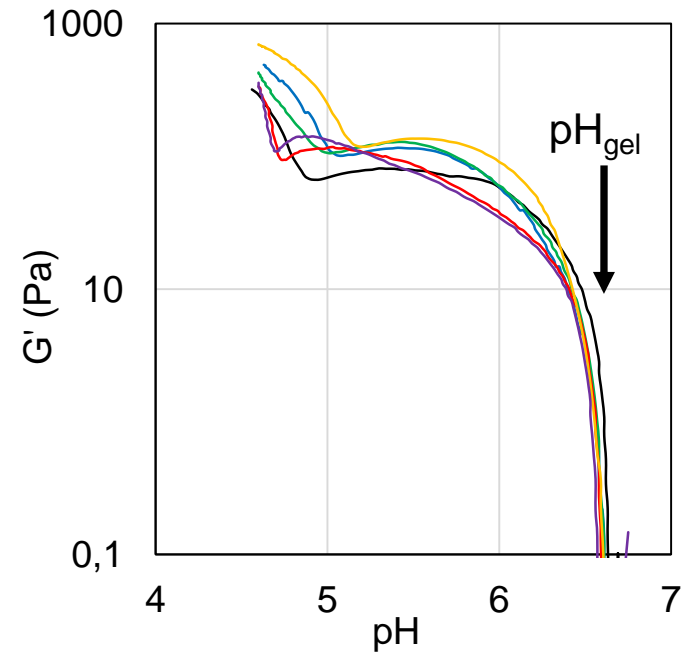
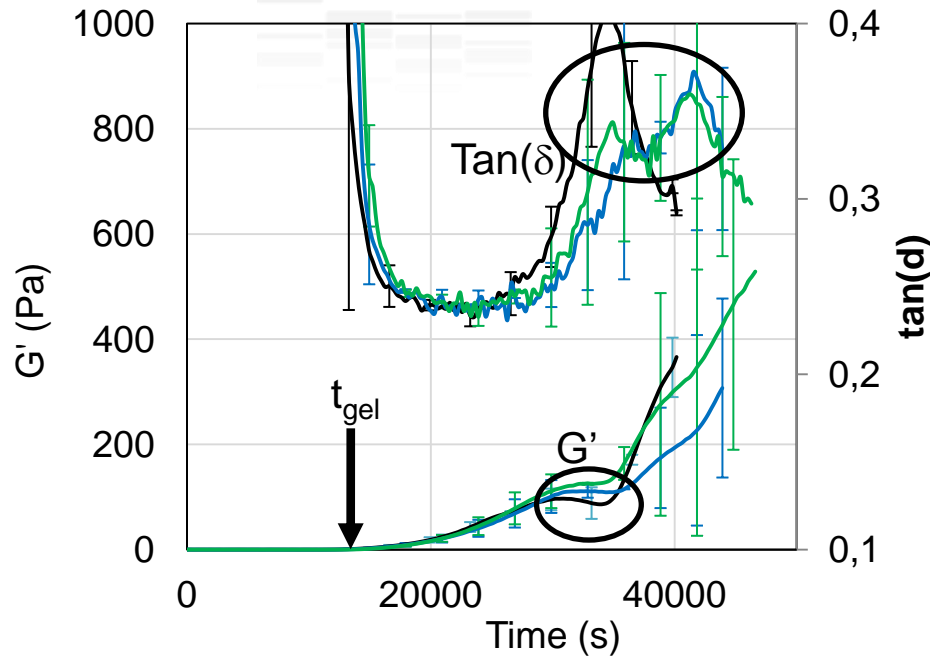

❖ Gelation at pH ~ 6.6: enzymatic gelation, then acidification ;

❖ A G' shoulder and a local maximum of $\tan(\delta)$: loosening of the colloidal particle = the casein micelle, due to acid-induced demineralization of the casein micelle around pH 5.0-5.2.

Results

Gel at pH 4.60 before stirring and draining

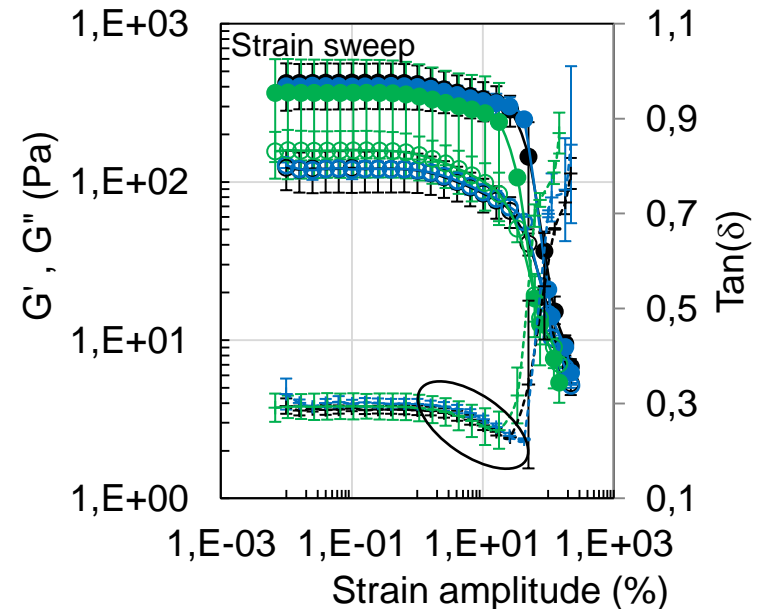
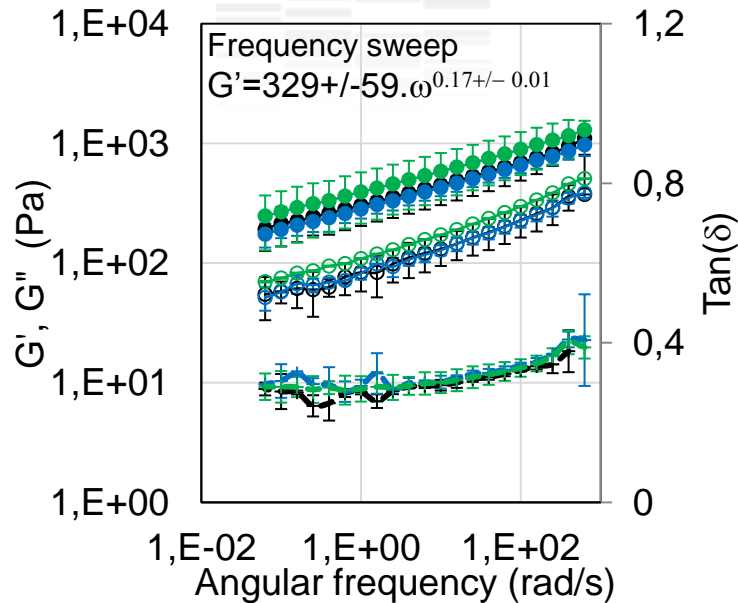

Dominant elastic gel, $\exp. = 0.17$ (Arshad et al., 1993, $\exp G' = 0.16$, $\tan(\delta) = 0.24-0.26$)

No cross-over of G' and G'' until $\gamma = 200\%$

- at $\omega = 1$ Hz, but at lower frequency ? (more time to relax) ;
- Entanglements between irregular surface clusters formed by shear?
- + slight $\tan(\delta)$ decrease before yielding: entanglements and/or strain-induced reorganization of the weak gel?

Then, the gel is either directly drained (24 h in the pilot) or stirred (i.e. microgels form) and then drained by centrifugation at increasing durations (3, 7, 15 and 30 min).

Results

Draining of the gel (stirred before centrifugation or unstirred before pilot)

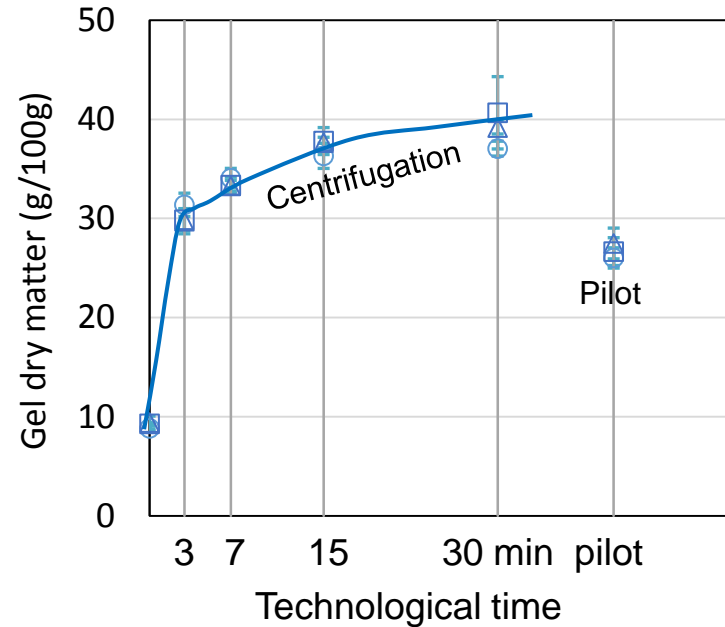
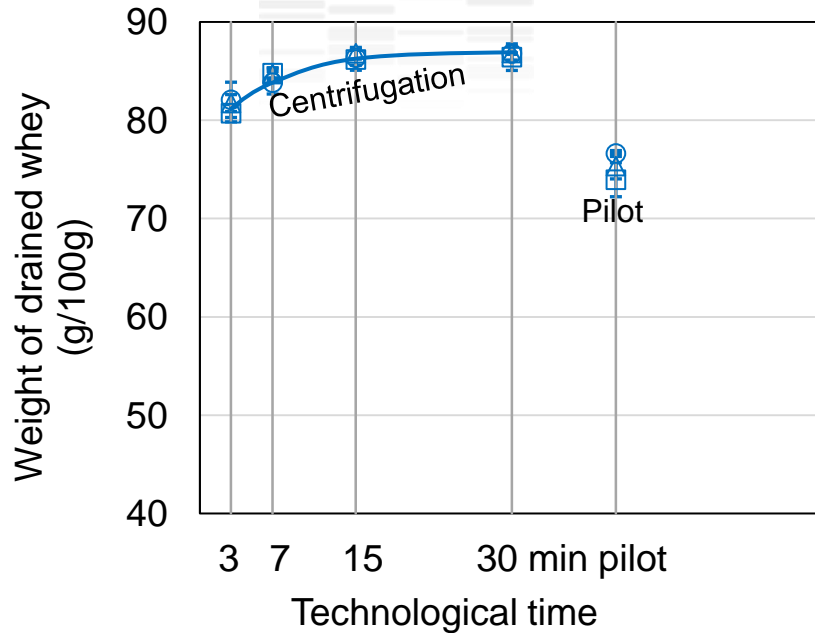

- ❖ High draining after only 3 min of centrifugation at 2800g ;
- ❖ Draining on the pilot is less intense than 3 min of centrifugation (but no stirring of the gel in the pilot) ;
- ❖ The gel dry matter increases as a consequence of draining.

Results

Consequences on rheological properties of drained gels: frequency sweep

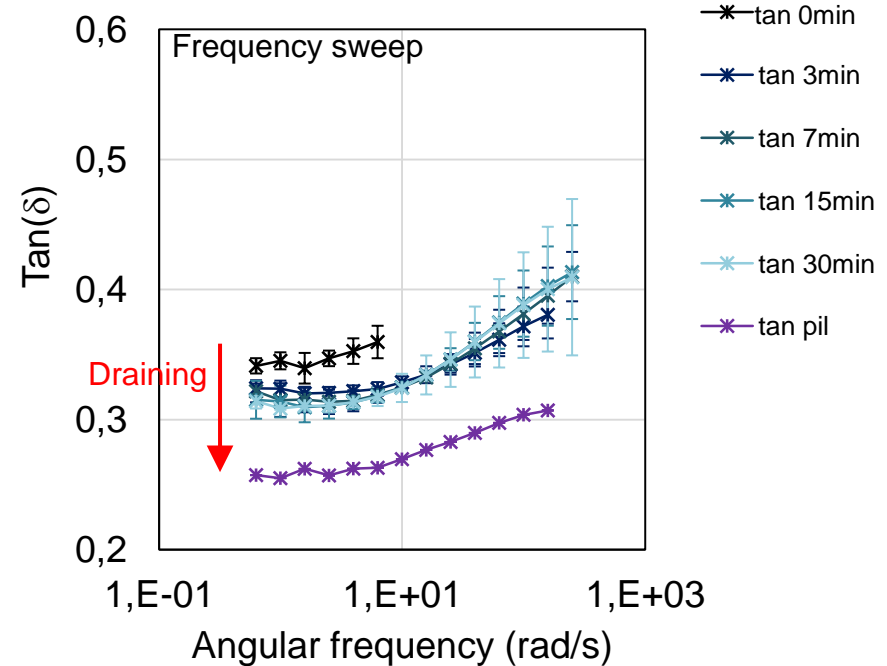
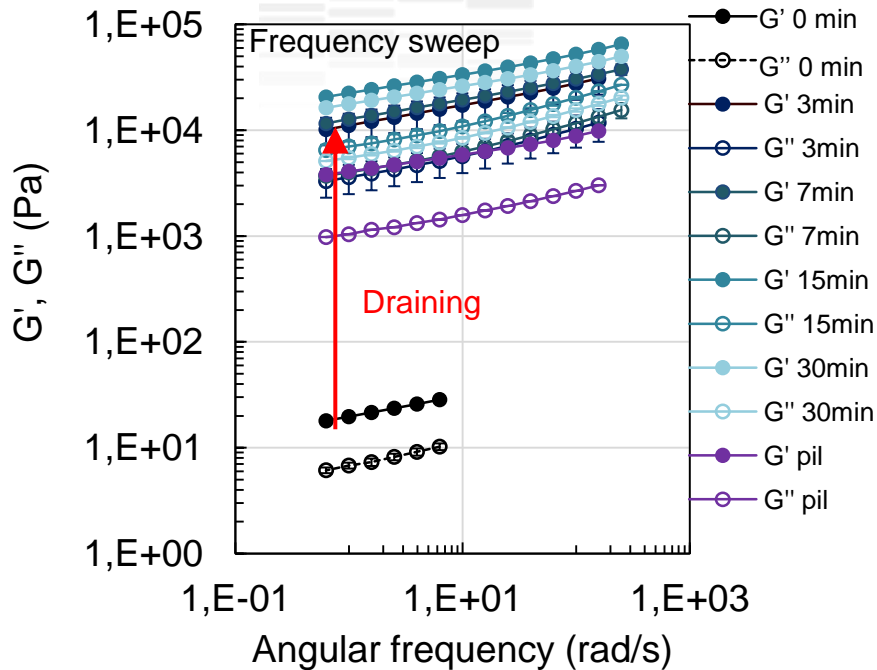

- ❖ Dominant elastic gels, $G' \sim 8-10 \times G''$
- ❖ Very few exponent and $\text{tan}(\delta)$ changes with draining - $\text{tan}(\delta) \downarrow$ with draining: more solid-like
- ❖ Gel drained on the pilot: lower $\text{tan}(\delta)$ than with centrifugation, more progressive draining without applied stress, but also no previous stirring in this process?

Results

Consequences on rheological properties of drained gels: strain sweep

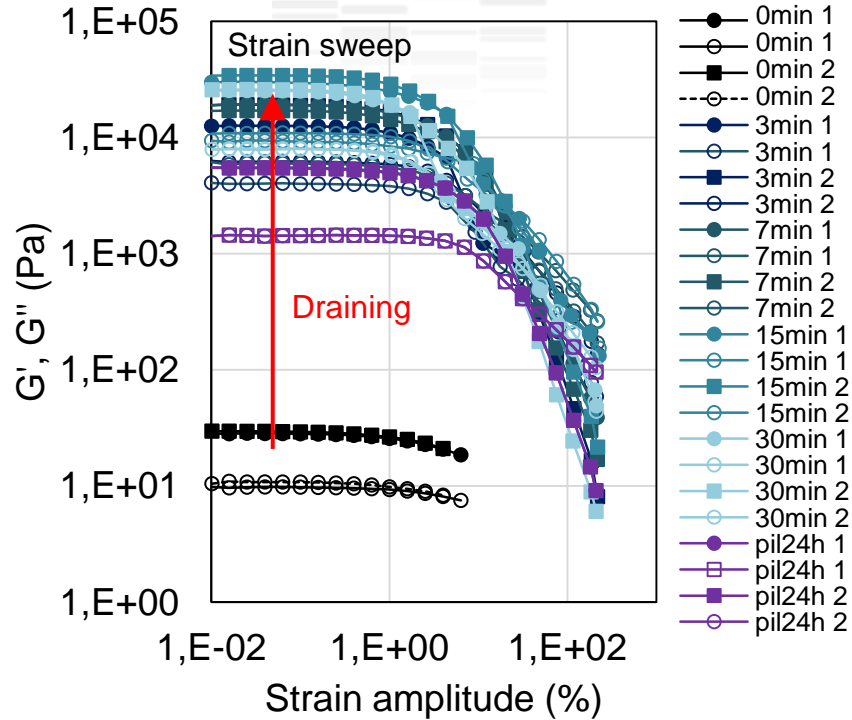

Yielding behaviour of type I, with no hardening or G'' overshoot

Results

Consequences on rheological properties

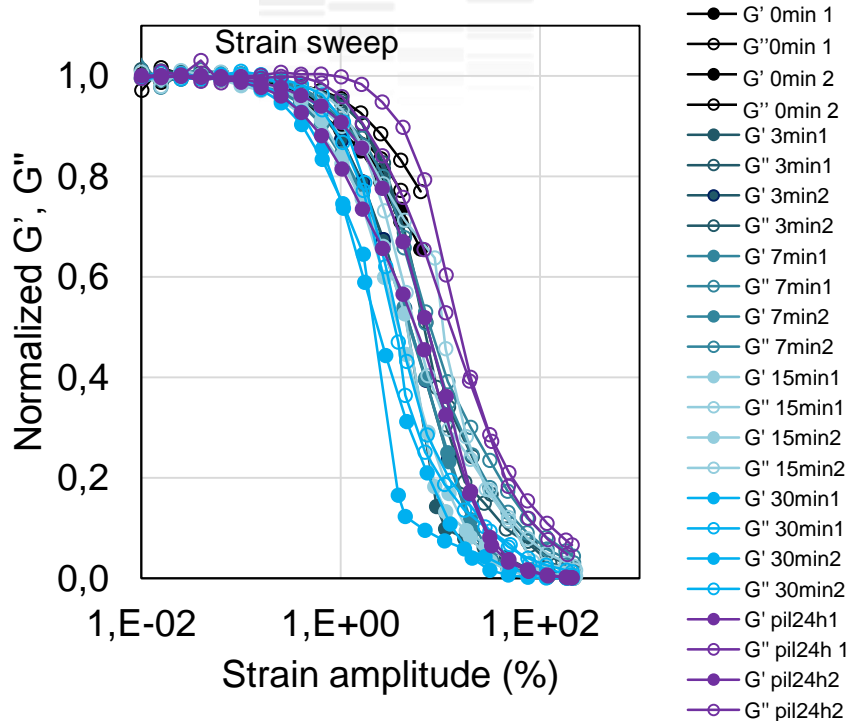

Yielding behaviour of type I, with no hardening or overshoot of G''

In agreement with other food gels (soy and whey proteins, Xia et al., 2022, Food Hydrocoll.).

Type I strain sweep found for polymers suspension and melts (# low shear = no effect, high shear = alignment of polymers).

In a solid-like gel:

- ❖ no real elastic network, i.e. no percolation or very weak interactions between microgels ?
- ❖ Suspension of microgels that have been packed by draining: high shear = disentanglements between microgels?

Results

Consequences on rheological properties

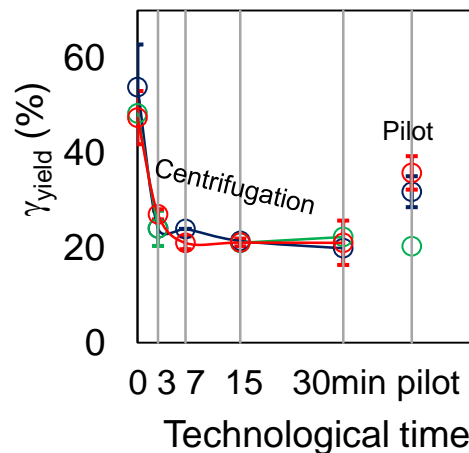
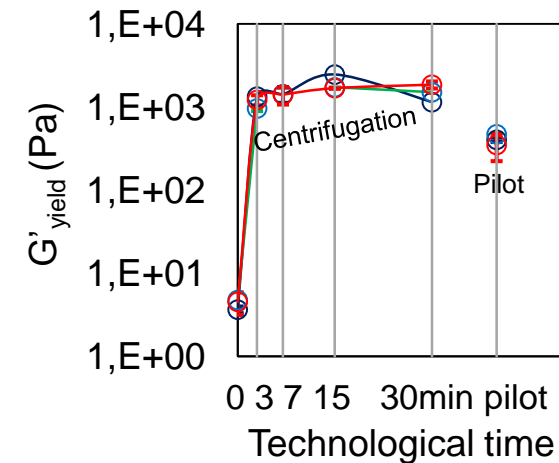
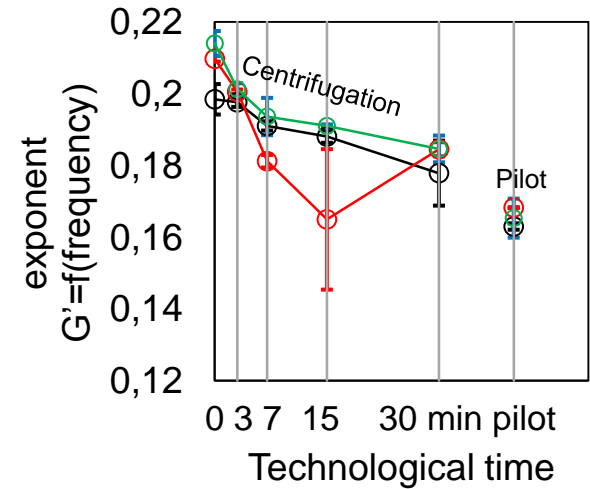
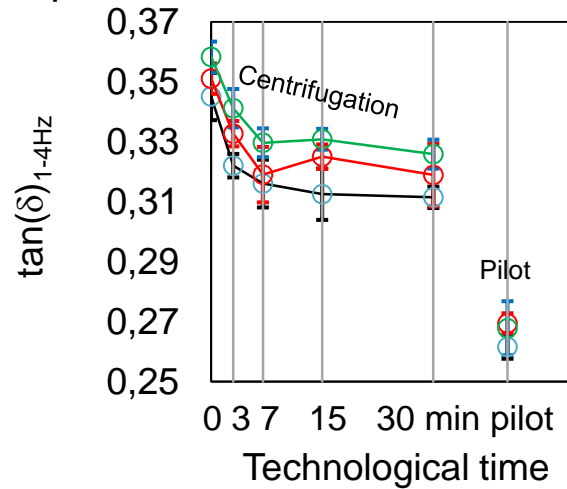
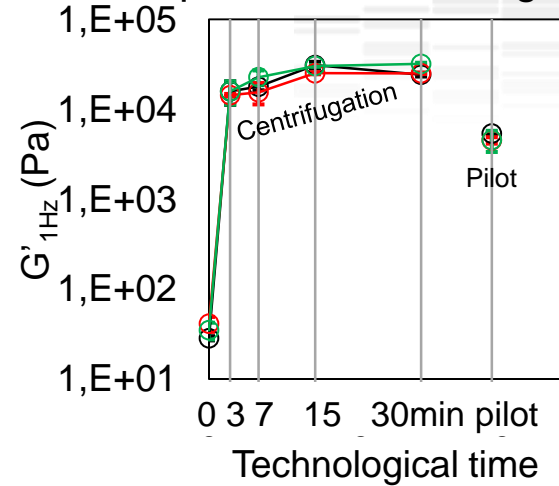

- Draining \Rightarrow Dry matter increase \Rightarrow
- ❖ G' increased dramatically between 0-3 min centrifugation (by 450 for $G'_{1\text{Hz}}$) and less then ;
 - ❖ Slight progressive decrease in $\tan(\delta)$ (slightly more solid-like);
 - ❖ Slight reduction in exponent of $G' \propto \text{freq}^{\text{exp}}$, (more rigid) and large decrease in yield strain (more rigid).

Results

Fractal structure of the gel

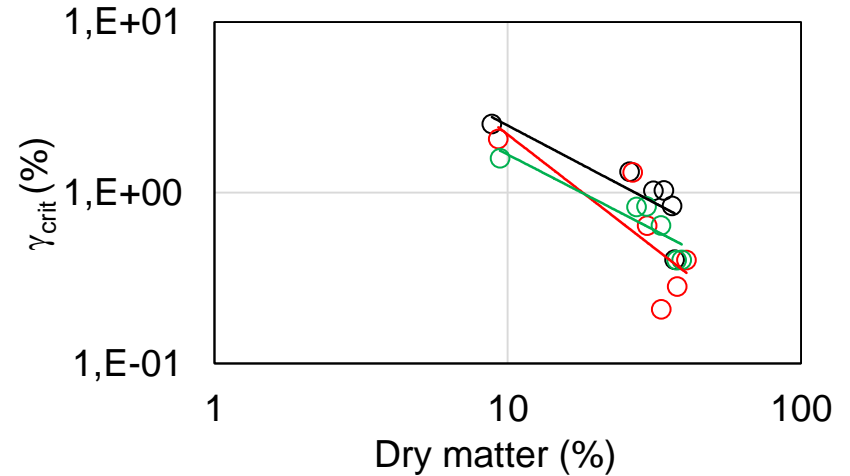
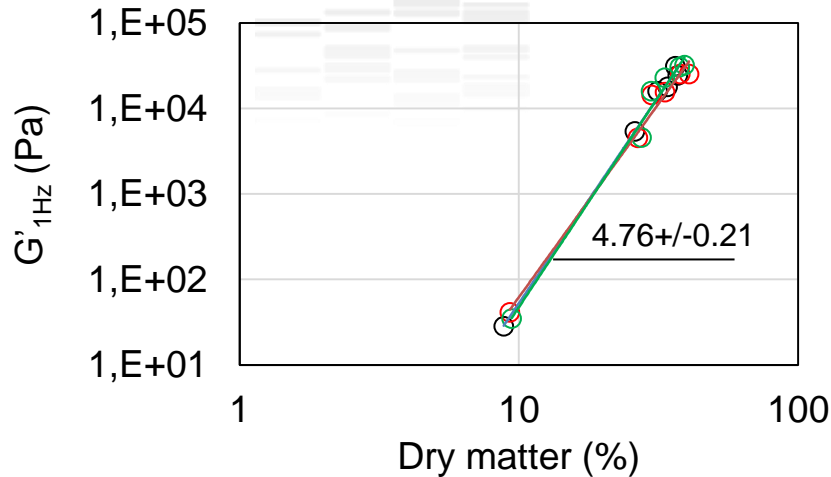

$G' \sim [\text{dry matter}]^{4.8 \pm 0.2}$ (Pitkowski et al., 2007; Zhong, 2004; Ikeda et al., 1999, Langmuir; Andoyo, et al., 2015; Alting et al., 2001; Marangoni et al., 2000)

Strong-link model (inter-microgel interaction > intra-microgel interaction) from Shih et al. (1990, Phys. Rev. A):

$D_f = 2.13 \pm 0.04$ (Acid or rennet gel, $D_f = 2.20$ (Bremer et al., 1989); Rennet casein gel, $D_f = 2.00-2.30$ (Vetier et al., 2000); Casein acid gel $D_f = 2.5-2.7$ (Andoyo et al., 2015).

$$G' \propto C^{(3+x)/(3-D_f)}$$

$$\gamma_{\text{crit}} \propto C^{-(1+x)/(3-D_f)}$$

- ❖ $G'_{1\text{Hz}} = f(\text{DM})$ at different intensity of draining on the same line = same structures/interactions (geometry, nature...) between microgels in the different drained acid gels
- ❖ Prediction of G' knowing the gel dry matter

Results

Microstructure

0 min centrif.

3min centrif

7min centrif

15min centrif

30min centrif

pilot

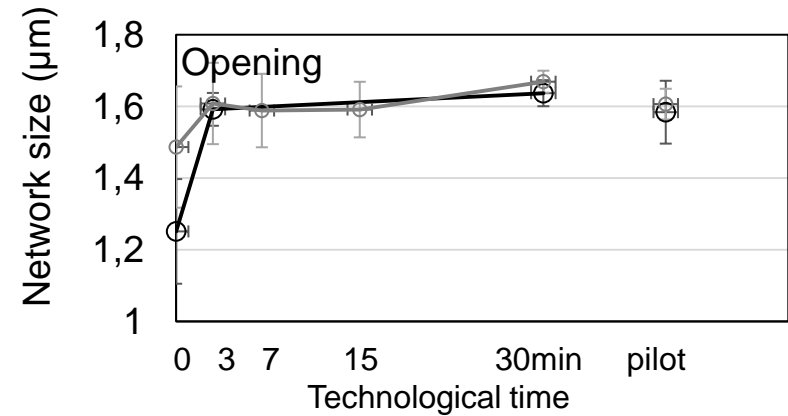
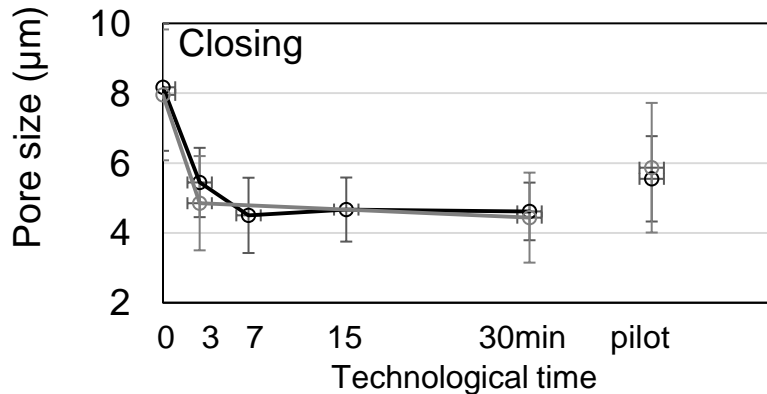
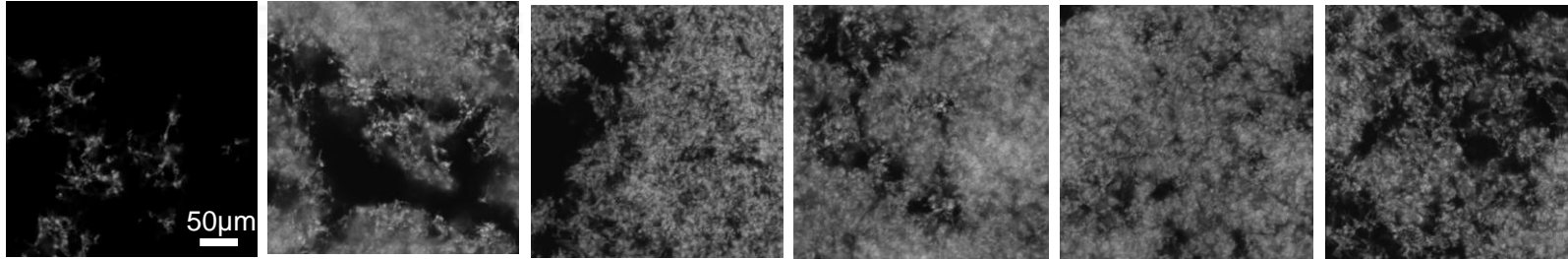

During draining:

- Pore size approximately halved,
- Slight increase in network size (<10%): slight thickening of the most frequent structures in the network (1-2 µm). Very few reorganizations,
- High difference between gel before draining and gel after 3 min of centrifugation and less modifications afterwards

Draining = compression of gel pores ?

Conclusions

Mixed (enzymatic and acid) skim milk gels form that are characterized.

- ❖ Formation of an enzymatic gel, then acidification ;
- ❖ It leads to acid dominant-elastic gel ;
- ❖ Stirring leads to a suspension of microgels.

Draining is performed by centrifugation or pilot-draining steps:

- ❖ Drained gels are also dominant elastic gels, with probably few or weak interactions between microgels ;
- ❖ Strong-link gels, i.e. inter-microgel interactions > intra-microgel interactions with a $D_f = 2.13 \pm 0.04$. Inter-microgel interactions are weak and intra-microgel interactions probably very weak (i.e. fluffy microgels) ;
- ❖ Draining consists mainly in the reduction by 2 of the mean pore size.

Studies underway on the effect of factors (fat addition, a severe preheating of milk...) on draining and rheology of acid cheeses



MERCI

**THANK YOU
FOR YOUR ATTENTION**

