



HAL
open science

Modelling Variable Speed Pumps for Flow and Pressure Control Using Nash Equilibrium

Jochen W Deuerlein, Sylvan Elhay, Olivier Piller, Michael Fischer, Angus R Simpson

► **To cite this version:**

Jochen W Deuerlein, Sylvan Elhay, Olivier Piller, Michael Fischer, Angus R Simpson. Modelling Variable Speed Pumps for Flow and Pressure Control Using Nash Equilibrium. Engineering Proceedings, In press, 10.3390/xxxxx . hal-04646678

HAL Id: hal-04646678

<https://hal.inrae.fr/hal-04646678>

Submitted on 12 Jul 2024

HAL is a multi-disciplinary open access archive for the deposit and dissemination of scientific research documents, whether they are published or not. The documents may come from teaching and research institutions in France or abroad, or from public or private research centers.

L'archive ouverte pluridisciplinaire **HAL**, est destinée au dépôt et à la diffusion de documents scientifiques de niveau recherche, publiés ou non, émanant des établissements d'enseignement et de recherche français ou étrangers, des laboratoires publics ou privés.



Distributed under a Creative Commons Attribution 4.0 International License

Modelling Variable Speed Pumps for Flow and Pressure Control Using Nash Equilibrium [†]

Jochen W. Deuerlein^{1,4,*}, Sylvan Elhay², Olivier Piller^{3,4}, Michael Fischer¹ and Angus R. Simpson⁴

¹ 3S Consult GmbH, Garbsen, Germany; deuerlein@3sconsult.de

² Sc. of Comp. and Math. Sc., Univ. of Adelaide, Adelaide, SA 5005, Australia; sylvan.elhay@adelaide.edu.au

³ INRAE, AQUA Division, UR ETTIS, F-33612 Cestas, France; olivier.piller@inrae.fr

⁴ Sc. of Arch. and Civ. Eng., Univ. of Adelaide, Adelaide, SA 5005, Australia; angus.simpson@adelaide.edu.au

* Correspondence: deuerlein@3sconsult.de; Tel.: (+49-721-20397-521)

[†] Presented at the 3rd International Joint Conference on Water Distribution Systems Analysis & Computing and Control for the Water Industry (WDSA/CCWI), Ferrara, Italy, July 1st – 04th.

Abstract: Recently the Nash-Equilibrium known from game theory was used for steady state calculation of pressurized pipe systems with general flow and pressure control devices. The concept is now applied to pumping stations. It is assumed that at least one of the pumps has a frequency controller that enables the pump to deliver a given set flow or set pressure by adaptation of pump speed. For hydraulic calculation the system is decomposed into the local pumping station and a surrogate link with flow or pressure constraints at one of its end nodes. The method is demonstrated for a small example system.

Keywords: Pump control, inverse problem, Nash-Equilibrium, Content Model, var. speed pump

1. Introduction

Pumps are indispensable components for the transport of fluids in pressurized pipe systems. The hydraulic behavior of a fixed-speed pump (FSP) is usually modelled by its characteristic curve, which may be adapted for variable speed pumps (VSPs) in hydraulic simulation software such as EPANET. In both cases, the operation of the pump is determined by a given relation between pump flow and pumping head. However, in real systems, the VSP is combined with a controller that allows adjusting the pump speed to reach a desired pump flow or downstream head. In this case the rpm of the pump is unknown and depends on the system hydraulics. Mathematical modelling of flow or pressure-controlled pumps is not as straightforward as in the case of FSPs. Instead, determining the pump speed that is required to reach a certain flow or pressure is an inverse problem that is more difficult to solve.

Recently, a mathematical framework for simulation of systems with flow and pressure regulating valves has been published [1-3]. The general approach was based on the Nash equilibrium of the flow constrained minimization of the Content function and local optimization problems for pressure control valves. In this paper, we extend this approach to also model flow and pressure-controlled pumps in water systems. For flow control a minimum flow bound is introduced. In contrast to how flow control valves (FCVs) are usually used, here the minimum flow bound has a positive sign. Consequently, the interpretation of the Lagrange Multiplier of the active flow constraint is not headloss but pumping head.

Rather the modelling of the VSP, which controls the downstream pressure, follows by adaptation of the authors' Nash equilibrium scheme for pressure regulating valves. In this case, the sign of the variable z , that refers to the headloss for valves, is inverted. A

Citation: To be added by editorial staff during production.

Academic Editor: Firstname
Lastname

Published: date



Copyright: © 2024 by the authors. Submitted for possible open access publication under the terms and conditions of the Creative Commons Attribution (CC BY) license (<https://creativecommons.org/licenses/by/4.0/>).

negative z can be interpreted as the head gain that is to be delivered by the pump to reach the required downstream pressure.

In both cases the Lagrange multipliers determine the operational state of the pump. A strength of this approach is that there is no need for heuristics. The paper demonstrates the adaptation of the Nash-Equilibrium approach to pump control. The method is illustrated with a small example.

2. Methods

2.1. Modelling of Pumping Stations

Pumps are essential components of water distribution systems. Normally, pumping stations do not consist of a single pump, but multiple pumps that are combined in parallel or in series. Such pump groups allow for improved operational flexibility and efficiency as well as increased system reliability since in case a pump fails it can be replaced by another stand-by pump. The pump characteristics of serial and parallel pumps are well known. If the pumps are in parallel their volume flow is added whereas for pumps in series their pumping heads are added.

Often one (or more) of the pumps is equipped with a frequency controller that enables the pump to respond to changing operational conditions in the system by adapting the pump speed (revolutions per minute) to reach the optimal efficiency. Such frequency controllers allow also the stepless control of the required pumping flow, pumping head or system pressure at a certain location where the control node can be directly downstream of the pumping station or at a distance. In real systems, combinations of frequency-controlled pumps and simple pumps can be found. Strictly speaking, the calculation of the required rpm for flow or pressure controlled pumping stations is an inverse problem formulated as a hierarchical optimization problem. These circumstances in combination make the stable calculation of general pumping stations a challenging task.

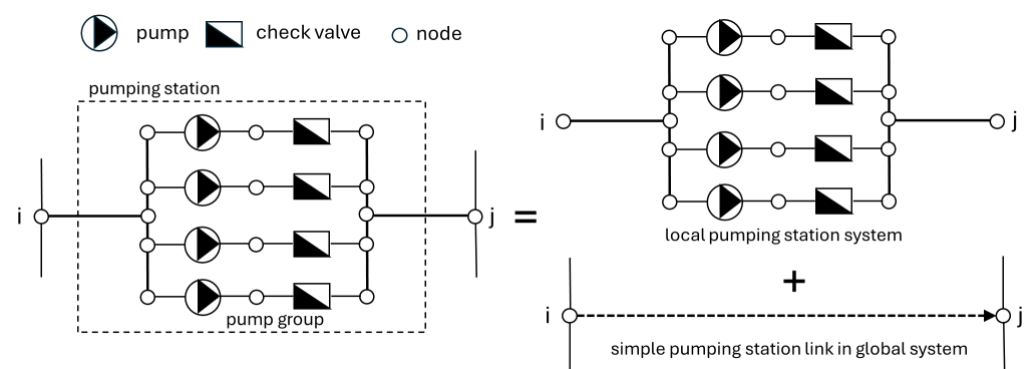

Figure 1. Decomposition of system with pumping station

The basic idea is to decompose the problem into the global hydraulic network simulation and local pumping station calculations (see Fig. 1). The steps are as follows: First, the pumping station is replaced by a simple link with unknown flow-head gain characteristics. In addition, a set value for this link (flow) or the downstream node head of the pumping station is defined. Once the solution for the global system has converged, within the local calculation step the combination of pumps and their rpm is determined for which the consumption of electrical energy is minimal. Other criteria for the local calculation are possible as well, for example by defining which pumps are required to be on stand-by in order to minimize deterioration of the material.

2.2. Mathematical Model

Recently, a comprehensive mathematical formulation for the calculation of the steady state of pressure dependent water supply networks including pressure and flow

regulating devices has been developed. In this approach, the Nash Equilibrium of multiple constrained nonlinear optimization problems is calculated. In this context, the Content Minimization for flow-controlled systems with pressure dependent demands is augmented by individual local optimization problems for each pressure control device (PRV: Pressure Reducing Valve, PSV: Pressure Sustaining Valve). Benefits of this approach include that it fully covers different operational states of the control devices and that conditions for existence and uniqueness of hydraulic steady-state can be derived from the rigorous mathematical model that does not rely on any heuristics. The Nash Equilibrium of the following convex optimization problems is calculated as

$$\min_{\mathbf{q}, \mathbf{c} \in B} C(\mathbf{z}; \mathbf{q}, \mathbf{c}) = \sum_{j=1}^{n_p} \int_0^{q_j} \xi_j(s) ds - \mathbf{a}^T \mathbf{q} + \mathbf{c}^T (\mathbf{u} + h_m) + \sum_{i=1}^{n_i} (h_s - h_m) \int_0^{c_i} \gamma^{-1} \left(\frac{s}{d_i} \right) ds + \mathbf{z}^T \mathbf{q} \quad (1)$$

$$\min_{z_k \geq 0} f(\mathbf{q}, \mathbf{c}; z_k) = \frac{1}{2} (h_{i_k}(\mathbf{q}, \mathbf{c}) - \xi(q_k) - z_k - h_{j_k}^s)^2, \quad \forall k \in I_z \quad (2)$$

The system has n_p links and n_i junctions, C is the content function, \mathbf{q} is the pipe flow vector and \mathbf{c} is the external flow vector of demand nodes. B stands for the polyhedron defined by the continuity equation combined with the box constraints for \mathbf{q} and \mathbf{c} . Vector \mathbf{u} denotes the geodetic elevation, h_m and h_s are the minimum head and the minimum supply head, respectively. The nonlinear functions ξ and γ refer to the frictional headloss and the pressure outflow relationship function (POR), respectively, and \mathbf{z} denotes the unknown headloss of pressure control devices. There is mutual feedback between the minimization problems. Whereas in the Content minimization the unknown headlosses are assumed to have constant values and the decision variables are the flows \mathbf{q} and \mathbf{c} , in the pressure control problem the flows are assumed to be fixed and the decision variables are the headlosses of the control devices. The Nash-Equilibrium (from mathematical game theory) of the various mutually combined optimization problems provides the solution [1].

The extension of the Nash-Equilibrium approach to the application for variable speed pumps is relatively straight forward. For pumping stations with flow control a minimum set flow for the link is added to the box constraints in Eq. (1). In this case the minimum flow bound is positive. Consequently, the Lagrange Multiplier represents a negative headloss in the positive link direction which is exactly the pumping head that is required to deliver the set flow. The pumping station with flow control can be modelled by the Content minimization [2, 3] (Eq. (1)) solely. In contrast, the second control mode for maintaining a given set pressure at the discharge side of the pump station requires the additional minimization problem according to Eq. (2). The situation is similar to the one with pressure control devices that adapt the headloss in order to keep the upstream pressure (PSV) or downstream pressure (PRV) constant [1]. The only difference is that the z value must be negative (pressure gain).

After convergence of the system equations the speed, the flow and the pumping head of the individual pumps of the local pumping stations are calculated. Besides the given set flow and pressure additional constraints can be added to the system equations that refer for example to the maximum capacity of the pumping station.

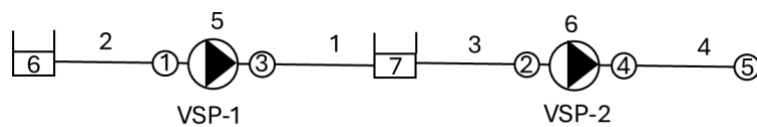

Figure 2. Example system with two VSPs: VSP-1 with flow control and VSP-2 with pressure control

3. Example Network

The system in Fig. 2 shows how a link with a positive lower flow bound, $q_{\min} > 0$ can model a pump and a link with head gain $z < 0$ can model a VSP. Each link has a diameter of 0.5 m and pipe roughness 0.25 mm. Nodes 6 and 7 have elevations 10 m and 200 m, respectively. Links 5 and 6 have lengths 1 m and all other links have length 1000 m. The service pressure head is 20 m and the minimum pressure head is 0 m. The head loss is modelled by the Darcy-Weisbach formula and the POR is a 1-side Regularized Wagner function of Deuerlein et al. (2019). The flow in Link 5, q_5 is constrained to $300 \leq q_5 \leq 600$ L/s and Node 4, downstream of Link 6, has $z < 0$ and its set point is 290 m.

The solution was found in 7 iterations of the authors' Matlab code, it has a delivery fraction of 75.9% (node 2: $c=107.59$ L/s, $q = 200$ L/s, node 3: 36.04 L/s, $q = 40$ L/s, node 5: $c=342.05$ L/s, $d = 400$ L/s) and the set point of 290 m (node 4) is achieved by a pumping head of $z = -99.2$ m. The heads at Nodes 1 (5.85m) and 3 (203.23m) indicate to a designer that the head gain that the pump in Link 5 would be required to provide is the value of the Lagrange multiplier of the minimum flow bound (300 L/s) for that link, $\kappa = 197.4$ m. The full data set can be obtained from the authors upon request.

4. Discussion and Conclusions

The methodology presented here is particularly suited for optimal design and operation of systems including pumping stations. In the first case, where the pumping station does not yet exist, the method allows the simulation of the pipe systems with consideration of design flows and/or pressures of the pumping station. In the second case, the local pumping station optimization can be combined with a global optimizer for the pipe system. The method has been used for the formation of a hierarchical optimization problem for optimal pump scheduling in a system with multiple storage tanks, pumping stations and springs. The decision variables of the upper optimization problem formulation are the pumping flows. The local pumping station optimization of the lower level calculates the combination of pumps and their speeds (if a frequency controller is available) that requires the minimum electrical power. The objective function of the upper level includes the total operational cost.

Author Contributions: Conceptualization and methodology, O.P., S.E., J. D., A.S.; software, S. E., M. F.; validation, S. E.; formal analysis, S.E., J.D., O.P.; original draft preparation, J.D.; writing—review and editing, all.; funding acquisition, J. D. All authors have read and agreed to the published version of the manuscript.

Funding: This research was partly funded by the German Ministry for Education and Research, grant number 02WQ1646.

Institutional Review Board Statement and Informed Consent Statement: Not applicable

Data Availability Statement: The raw data supporting the conclusions of this article will be made available by the authors on request.

Conflicts of Interest: The authors have no conflicts of interest to declare.

References

1. Deuerlein, J.W.; Elhay, S.; Piller, O.; Simpson, A.R. Modeling Flow and Pressure Control in Water Distribution Systems Using the Nash Equilibrium. *J. Water Resour. Plan. Manag.* **2023**, *149*(6), 16 pages.
2. Elhay, S.; Piller, O.; Deuerlein, J.W.; Simpson, A.R. An Interior Point Method Applied to Flow Constraints in a Pressure-Dependent Water Distribution System. *J. Water Resour. Plan. Manag.* **2022**, *148*(1), 15 pages.
3. Piller, O.; Elhay, S.; Deuerlein, J.W.; Simpson, A.R. A Content-Based Active-Set Method for Pressure-Dependent Models of Water Distribution Systems with Flow Controls. *J. Water Resour. Plan. Manag.* **2020**, *146*(4), 13 pages.

Disclaimer/Publisher's Note: The statements, opinions and data contained in all publications are solely those of the individual author(s) and contributor(s) and not of MDPI and/or the editor(s). MDPI and/or the editor(s) disclaim responsibility for any injury to people or property resulting from any ideas, methods, instructions or products referred to in the content.