



**HAL**  
open science

# O-AMIE: A tool combining systems engineering and life cycle assessment to eco-design agricultural practices and assess their environmental impacts

Marilys Pradel, Romain David, Fabien Gaudin

## ► To cite this version:

Marilys Pradel, Romain David, Fabien Gaudin. O-AMIE: A tool combining systems engineering and life cycle assessment to eco-design agricultural practices and assess their environmental impacts. Computers and Electronics in Agriculture, 2024, 227, pp.109558. 10.1016/j.compag.2024.109558 . hal-04743055

**HAL Id: hal-04743055**

**<https://hal.inrae.fr/hal-04743055v1>**

Submitted on 18 Oct 2024

**HAL** is a multi-disciplinary open access archive for the deposit and dissemination of scientific research documents, whether they are published or not. The documents may come from teaching and research institutions in France or abroad, or from public or private research centers.

L'archive ouverte pluridisciplinaire **HAL**, est destinée au dépôt et à la diffusion de documents scientifiques de niveau recherche, publiés ou non, émanant des établissements d'enseignement et de recherche français ou étrangers, des laboratoires publics ou privés.



Distributed under a Creative Commons Attribution 4.0 International License

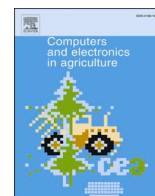

# O-AMIE: A tool combining systems engineering and life cycle assessment to eco-design agricultural practices and assess their environmental impacts

Marilys Pradel <sup>a,\*</sup>, Romain David <sup>a</sup>, Fabien Gaudin <sup>b</sup>

<sup>a</sup> Université Clermont Auvergne, INRAE, UR TSCF, centre de Clermont-Ferrand, Domaine des Palaquins, 40 route de Chazeuil, 03150 Montlondre, France

<sup>b</sup> Sherpa Engineering, 2 Rue Alfred Kastler, 44300 Nantes, France

## ARTICLE INFO

### Keywords:

Life cycle assessment  
Systems engineering  
Model-based design  
Crop management

## ABSTRACT

Agricultural practices are responsible for several environmental impacts; thus, sustainable practices need to be promoted. Environmental impacts of agricultural practices can be estimated using life cycle assessment (LCA). However, since agricultural systems are complex due to their strong interactions with the environment, specific methods need to be used to assess them. To meet this objective, this study combined systems engineering and life cycle assessment, supported by development of the tool O-AMIE (*Outil d'Analyse et de Management des Impacts Environnementaux* in French; Environmental impact analysis and management tool, in English), using Matlab®, Simulink® and the platform PhiSim (Sherpa Engineering). This tool was developed to help users design and validate operating systems used in agriculture (e.g., tractors, robots), calculate environmental impacts of process systems that use these operating systems (e.g., a complete set of crop management, field operations and cropping techniques) and provide a framework for standardizing agricultural LCAs. Here, we specifically focused on the conceptual framework and model of O-AMIE as well as the model-based design used to build high-level field-operation models.

## 1. Introduction

Agriculture is responsible for several environmental impacts, such as degradation of soil, water and air quality; water scarcity and biodiversity loss. Despite these serious impacts, agriculture can also have positive effects on the environment by trapping carbon dioxide in perennial crops and soils, maintaining landscapes or mitigating biodiversity loss through certain farming practices (OECD, 2023). Identifying sustainable agricultural practices relies on integrated assessment methods to compare possible alternatives. The variety of challenges and perspectives related to agricultural systems requires a transition toward systems thinking that includes environmental impacts of these alternatives (Sala et al., 2017).

Environmental performances of agricultural systems can be assessed using life cycle assessment (LCA), a reference framework that estimates multiple environmental impacts at all stages of a system's life cycle, with the aim of achieving environmental sustainability objectives (ISO, 2006a; ISO, 2006b; ILCD Handbook, 2010). LCA, and by extension life cycle thinking, is applied to i) identify "hotspots" of environmental impact in agricultural systems, ii) compare options for agricultural practices focused on either the means of production (e.g., machinery,

fertilization) or crop and livestock production as a whole (e.g., organic vs. conventional) toward sustainable solutions and iii) assess future scenarios that explore technological improvements, behavioral changes and effects of different environmental conditions (e.g., climate change) (Notarnicola et al., 2017; Sala et al., 2017). However, the complexity of agricultural systems requires using a method developed for large and complex systems to assess multiple scenarios to achieve sustainable practices.

Systems engineering (SE) is an interdisciplinary field that focuses on the design, analysis, integration and management of complex systems. The International Council on Systems Engineering (INCOSE) defines it as a "transdisciplinary and integrative approach to enable the successful realization, use, and retirement of engineered systems, using systems principles, concepts, scientific, technological, and management methods" (INCOSE, 2023). To gain insight into a complex system's structure and behavior, SE is often used to address the system's interacting elements in relation to the targeted problem and type of development. Consequently, SE allows specific trade-offs to be made to achieve the most favorable outcome for the system under study (Kossiakoff and Sweet, 2003).

SE has been used in the agricultural sector to analyze fish production

\* Corresponding author.

E-mail address: [marilys.pradel@inrae.fr](mailto:marilys.pradel@inrae.fr) (M. Pradel).

**Table 1**  
Terms and definition used in Model-Based System Engineering (MBSE) and Life Cycle Assessment (LCA).

Term	MBSE definition	LCA definition
Perimeter	Also called system of interest (SOI), which determines the system to be studied.	Also called system boundaries, which are a set of criteria that specify which unit processes are part of a product system
Function	The most similar item is the service function, a high-level function that explains the service rendered by the system and that carries a certain performance	Service provided by the system under study
Functional unit	–	Quantified performance of a product system for use as a reference unit
Product system	System to be studied	Set of unit processes with elementary and product flows that perform one or more defined functions, which models the life cycle of a product
Process	Has the same role as a function. In SE, a set of functions that provide a service is similar to the structural-functional unit (SFU) concept	Set of correlated or interactive activities that transform inputs into outputs
Input	From a functional viewpoint: a product, material or energy flow that enters a SFU	A product, material or energy flow that enters a unit process
Intermediate flow	–	A product, material, or energy flow between unit processes of the product system being studied
Elementary flow	–	Material or energy entering/leaving the system being studied that is drawn from/released to the environment without previous/subsequent human transformation
Product flow	–	Products that enter or leave another product system
Output	From a functional viewpoint: a product, material or energy flow that leaves a SFU	A product, material or energy flow that leaves a unit process
Reference flow	–	Measure of the outputs from processes in a given product system required to fulfil the function expressed by the functional unit
Flows	Also called energy-material-information (EMI) flows, which connect the SFU or SOI to its stakeholders	Same definition as reference flow, depending on the type of flow
Scenario	Sequence of events and transformations that specify exchanges between systems in a given situation	Sequence of processes for transforming inputs into outputs

and decrease post-harvest loss of farmed salmon during processing in Norway (Fet et al., 2010; Abualtaher and Bar, 2020). Fet et al. (2010) used SE to analyze the fish production system as a whole, while Abualtaher and Bar (2020) used SE to gain holistic understanding of the system by analyzing system components, stakeholders and the system's behavior to discuss scenarios that had adaptations required to decrease losses. Several studies also developed decision-support systems (DSS) based on SE principles that allow whole-farm systems to be simulated (Del Prado et al., 2011; Schils et al., 2007; Smith et al., 2016; Rotz et al., 2022); these DSS represent interactions among farm management and the environment. For example, the Integrated Farm System Model simulates crop production, feed use and nutrient recycling back to the soil, as well as nitrogen (e.g., ammonia, nitrate), phosphorus and greenhouse gas emissions to the environment (Rotz et al., 2022), which allows it to

estimate water and carbon footprints and energy use. Other DSS quantify effects of technologies on livestock and crop farms, such as the Tractor Guidance Analysis (Lindsay et al., 2018), which estimates expected improvements in yield, input costs, equipment efficiency and the carbon footprint associated with using global positioning system guidance on tractors.

Thus, as a holistic approach, SE has been demonstrated to be a robust framework that can incorporate life cycle thinking, life cycle environmental impact assessment and stakeholder views. It can consider environmental concerns and provides a basis for combining life cycle management tools and environmental concerns in design principles. Fet et al. (2013) showed that SE can serve as a project-management tool that can adopt parts of other tools if necessary. They noted that LCA aligns with the six steps of the SE method: LCA's step 1 – "Goal and scope definition" – aligns with SE's step 1 and 2 – "Identify needs" and "Define requirements". LCA's step 2 – "Inventory analysis" – can be achieved through SE's step 3 – "Specify performance", while LCA's steps 3 and 4 – "Impact assessment" and "Interpretation" – can be achieved through SE's step 4 – "Analyze and optimize". Finally, SE's steps 5 and 6 – "Design and solve" and "Verify and test" – are similar to application of LCA results in a design process (Fet et al., 2013).

Several studies used SE principles to establish the goal and scope of LCA to better define functions and functional units using a functionally decomposed model based on SE principles (Esterman et al. 2012; Gadre et al., 2017). By using SE principles, these studies were able to (i) establish system boundaries based on system functionality instead of on physical systems or manufacturing processes, (ii) identify reference flows and scaling parameters, (iii) integrate use behavior into the definition of the functional unit and (iv) decompose the system into sub-functions using a functionally decomposed model, which allows the framework to be dynamic and simple to update as data quality improves. This method allowed studies to implement an object-oriented (i.e., modular) LCA to help designers use LCA results in the design phase of a product, since 80 % of a product's environmental impact is defined during this phase (Bohm et al., 2010).

Traditionally relying on written documents as sources of managerial information, SE approaches have moved for several years to model-based approaches. These model-based system engineering (MBSE) approaches are increasingly adopted by industries and governments and studied as a major research topic in academia (Henderson and Salado, 2021). MBSE combines models and systems thinking. Models can be defined as conceptual, mathematical or physical tools that represent a system's components and behaviors and can assist decision-makers by providing multidimensional predictions and supporting rigorous management and changes in design (Le et al., 2023). MBSE can be supported by model-based design (MBD), a math-based visual method for designing and assessing physical systems and using simulation to understand the behavior of existing or future physical systems (MathWorks, 2023). Both MBSE and MBD are successfully used in many motion-control, aerospace and automotive applications. However, unlike LCA, they are not used in the agricultural sector and do not include environmental components. To fill this gap, we developed the O-AMIE tool, which combines MBSE and LCA principles to design agricultural practices and estimate environmental impacts of agricultural operations. O-AMIE was designed to allow collaborative work between LCA practitioners and those who design products used as means of production (e.g., tractors) or agricultural operations, by simulating their functional performances and environmental impacts simultaneously. It provides three innovations. First, it estimates environmental impacts dynamically (i.e., over the course of a scenario), unlike traditional LCA, which estimates environmental impacts at a given point in time. Second, the foreground inventory data it uses to estimate environmental impacts is based on the physical reality of the system studied instead of the mean data used by traditional LCA. Finally, it can process a huge number of use scenarios rapidly. This approach returns ecological issues to the heart of the design process and allows agricultural practices and thus

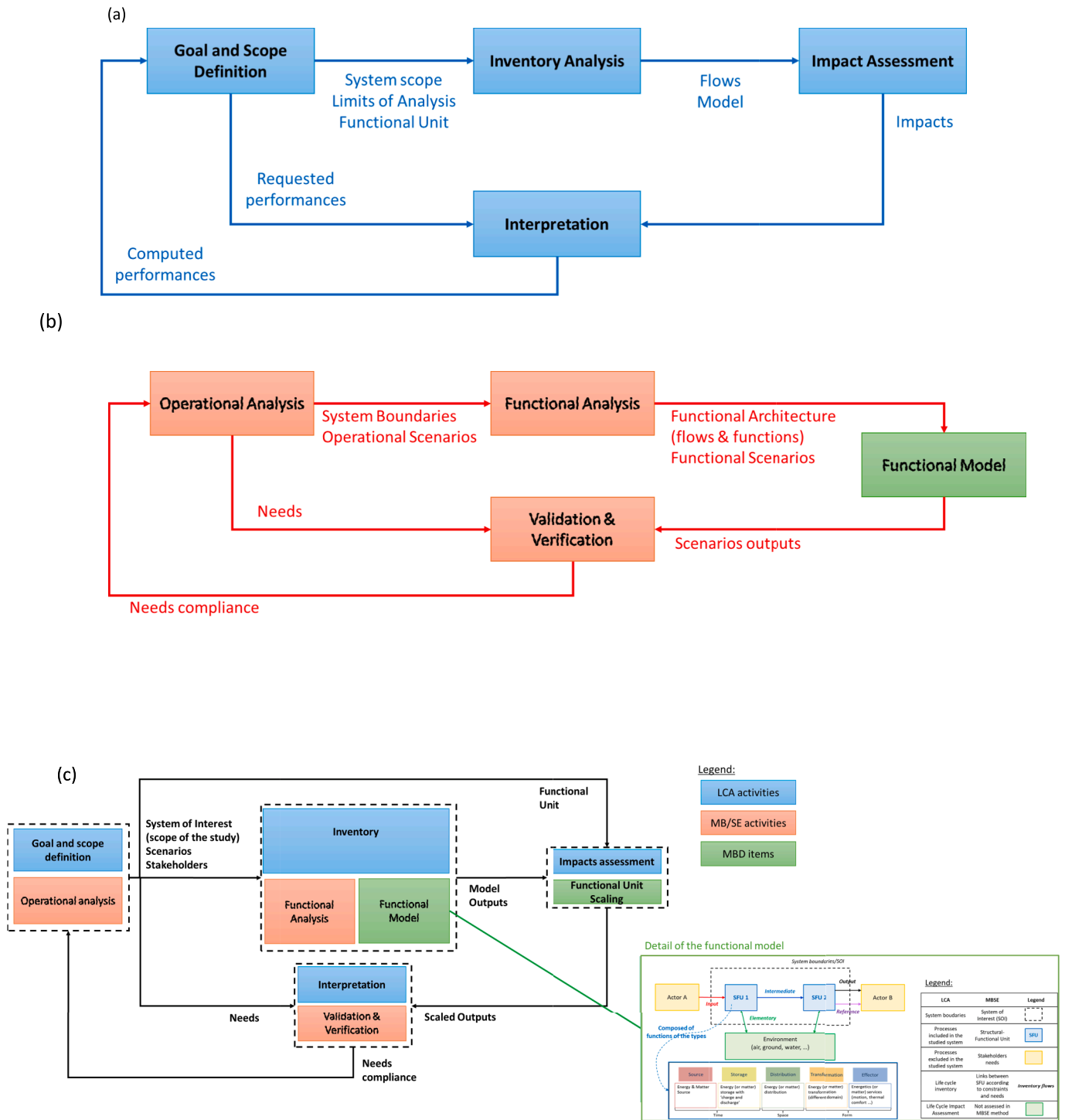

Fig. 1. Diagrams of (a) Life Cycle Assessment (LCA) activities, (b) Model-Based System Engineering (MBSE)/Model-Based Design (MBD) activities and (c) combined MBSE/MBD and LCA activities.

agricultural systems to be eco-designed. Here, we present the method used to combine MBSE and LCA, as well as the conceptual framework, model and generic MBD modeling behind O-AMIE.

## 2. Method for combining MBSE and LCA

LCA is a four-step framework based on international standards (ISO, 2006a; ISO, 2006b; ILCD Handbook, 2010). The first step is to define the goal and scope of the study: the system studied, its boundaries and

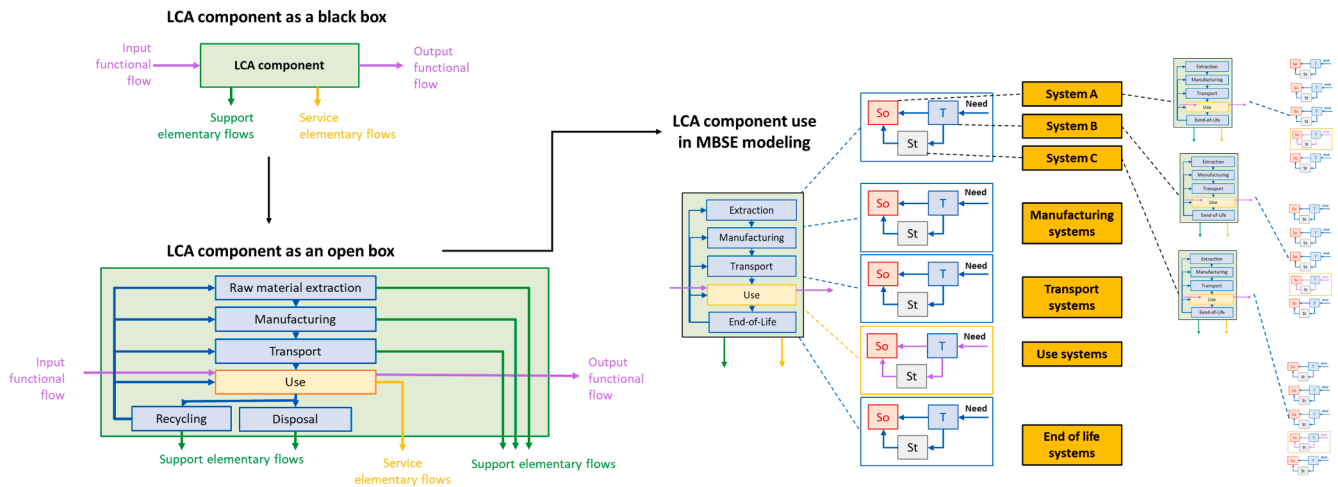

Fig. 2. Integration of LCA components in MBSE modelling (So: source, St: storage, T: transformation).

functions, and the related functional unit (the reference to which all inventory data are related), the allocation methods used and the assumptions made in the study. The second step is life cycle inventory (LCI), during which all inputs (e.g., raw materials, energy) and outputs (e.g., emissions) related to each process in the system are considered. The third step is life cycle impact assessment (LCIA), which relates the inputs and outputs of the system to environmental impacts. In the fourth step, the results are interpreted based on the system boundaries and assumptions chosen.

MBSE is a systems approach for modeling complex systems that has three steps. The first step defines the operational level of the system studied by specifying the system’s objectives and missions, and the purposes of the products it produces (i.e., why the system exists). The second step defines the functional level of the system (i.e., which functions allow the system to reach its goals). The third step specifies the processes that allow the system to fulfill these functions. This section describes the terms and definitions of each method and how we combined the methods.

2.1. MBSE and LCA terms and definitions

Both MBSE and LCA consider system boundaries, functions and processes, and use similar terms and concepts; however, they may define these terms differently. The first step in this study’s approach was to understand the terms used by MBSE and LCA (Table 1).

2.2. Combining MBSE and LCA approaches

MBSE and LCA also have similar approaches to modeling systems, but to our knowledge, no published study has combined MBSE and LCA. Thus, we analyzed MBSE and LCA and developed an MBSE representation using more accurate LCA terms. By summarizing the steps of LCA activities (Fig. 1a) and their equivalents in SE (Fig. 1b), we developed a combined representation of the two methods (Fig. 1c).

The LCA activity “Goal and scope definition” was equated with MBSE’s operational analysis. LCA’s “Inventory” provides input/output flows in the same way as MBSE’s functional analysis, while LCA’s “Impact Assessment” and “Interpretation” are based on the results of MBSE’s functional simulation. Since the functional analysis creates a functional architecture, it is possible to produce a functional model that can be run to produce input for the LCA activities.

Nonetheless, it was necessary to express the results according to the functional unit so that they could be interpreted. In this way, LCA activities feed and can be fed by SE studies and the resulting functional models. The functional model is built with multiple elements (Table 1),

which is sufficient to perform the simulations, and the accuracy of the results is a function of the accuracy of the structural–functional unit models.

2.3. The LCA component, a specific structural–functional unit dedicated to eco-design

O-AMIE aims to help practitioners eco-design agricultural practices by simplifying assessment of environmental impacts of technical solutions. To reach this objective, we created simulation models that contain both physical models, to assess functional performance, and LCA models, to assess environmental impacts, all in relation to a mission (i.e., here, crop management). Thus, O-AMIE combines LCA components using MBSE approaches. Each component is built to be used alone or with other LCA components to build larger system models. Unlike traditional MBSE modeling, the LCA component includes all life cycle steps of the system components. The physical model used to simulate the system to assess its functional performance is part of the “Use” phase (e.g., tractor used for field operations, including transport from the farm to the field and fuel consumption) (Fig. 2).

This approach is consistent with operational analysis, in which support systems (i.e., systems that allow other systems to function) lie outside the system of interest. The life cycle phases of the system are represented well in the form of needs/constraints, but support systems are not included. The other phases (extraction, manufacturing, transport, end-of-life) are based on the LCA model. In a black box (Fig. 2), there is thus a unitary component that interacts with the other LCA components via functional flows. The elementary flows from support systems (i.e., phases besides the use phase) are distinguished from the elementary flows generated by the system of interest when it provides its services.

3. SE/LCA design principles for O-AMIE

O-AMIE contains generic and specific component models that include indicators of environmental impacts throughout the life cycle. Given the tool’s modular approach, users can select and set up these objects to model the desired crop management, field operation or cropping technique and estimate their environmental impacts. First, a context diagram was developed to help define the tool’s scope, and then functional analysis was performed to analyze the functions that O-AMIE could fulfill and to build its model-based design.

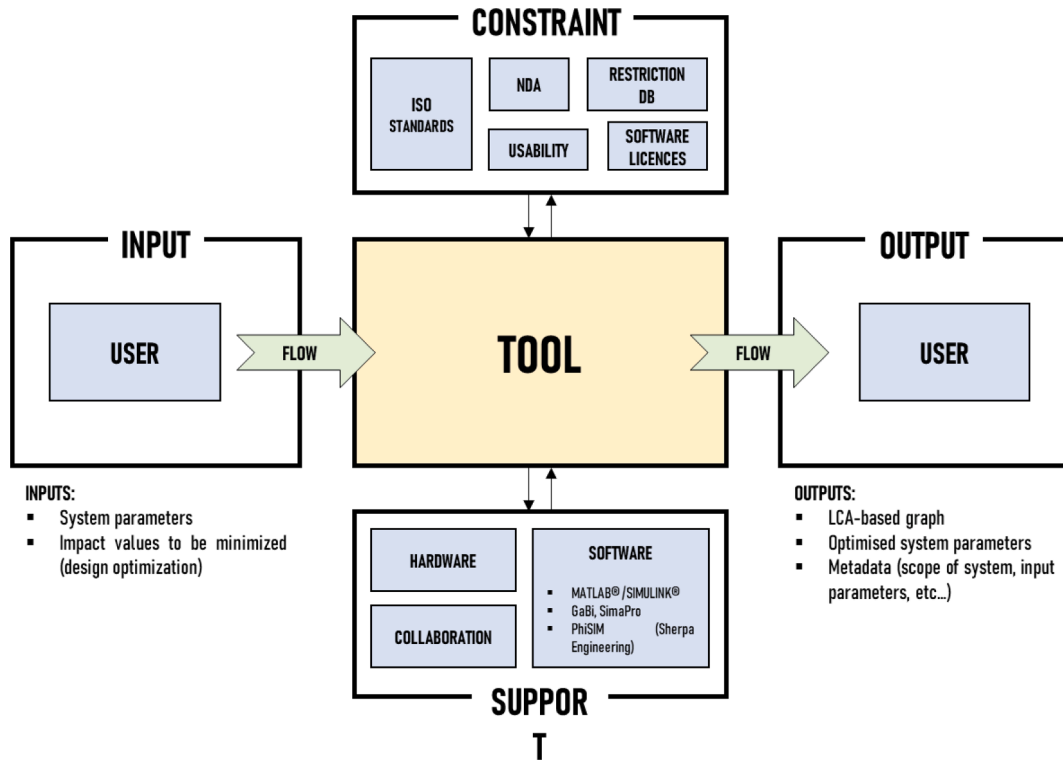

Fig. 3. Context diagram of the O-AMIE tool.

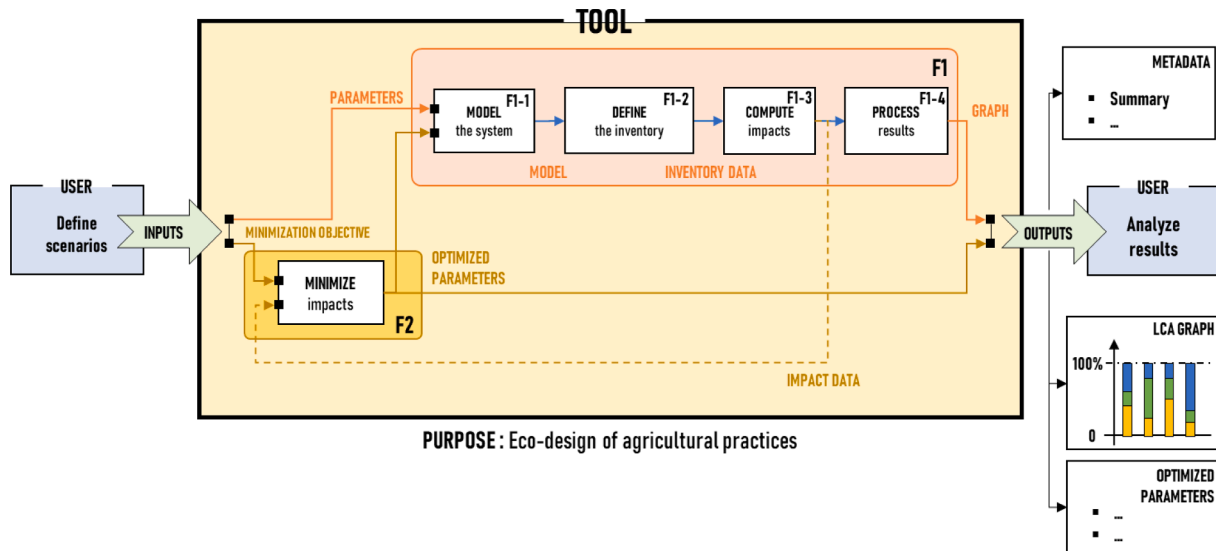

Fig. 4. Functional analysis of the O-AMIE tool.

### 3.1. Operational analysis – Context diagram

Several constraints were identified in the context diagram (Fig. 3). First, the tool had to be integrated completely into LCA’s methodological framework to follow ISO standards. Usability and the availability of data to process the LCI and simplified results could also have been constraints due to software and license-agreement requirements. Regarding support, strong collaboration among stakeholders is required to obtain specific data for the LCI and modeling. O-AMIE was built using Matlab®/Simulink® and PhiSim (a multi-physics modeling and simulation platform developed by Sherpa Engineering) to model the system and conventional LCA software (e.g., SimaPro®, GaBi®, OpenLCA) to

provide indicators of environmental impacts for models from open-access databases.

### 3.2. Functional analysis

O-AMIE is used to model, assess and optimize an agricultural system. Before using it, users must define scenarios by defining two major intrinsic functions (Fig. 4). The first function (F1) – environmental impact assessment (EIA) – includes four sub-functions to follow LCA guidelines: modeling the system (F1-1), defining the inventory (F1-2), calculating impacts (F1-3) and processing results (F1-4). The second function (F2) – eco-design – depends on F1 and includes an additional

**Table 2**

Main inputs and outputs of the O-AMIE tool for the associated functions of environmental impact assessment (F1) and eco-design (F2).

Function	Inputs	Outputs
F1	System parameters given by users when defining the system. They are related to features of the crop management, field operation or cropping technique (e.g., tractor power, volume of mixture to be sprayed).	Typical LCA-based graph that shows the main contributions of field operations to the environmental impacts. Other typical graphs can also be displayed.
F2	A minimization objective as a set of impact values to be minimized (e.g., x kg CO <sub>2</sub> eq for climate change, x kg SO <sub>2</sub> eq for acidification, costs of changes in actions)	Optimized parameters of the system (e.g., optimized volume of the mixture to be sprayed).

phase of minimizing impacts using a feedback loop (dashed line in Fig. 4), which helps find optimized parameters of the system (e.g., optimized mixture to be sprayed, L of fuel consumed by the tractor, greenhouse gas emissions). Both functions are performed in the background of the tool and inaccessible to users, unlike the user options that allow users to use the tool. See Table 2 for the main inputs and outputs in the context diagram (Fig. 3).

3.3. Structural analysis – Conceptual framework of O-AMIE

O-AMIE is designed to help design and validate operating systems involved in agriculture (e.g., tractors, robots), estimate environmental impacts of process systems that use these operating systems (e.g., field operations, cropping techniques) and provide a framework for standardizing agricultural LCAs. The conceptual framework was built to fulfill the EIA (Steps 1–4) and eco-design (Step 5) functions (Fig. 4). Since the eco-design function is still under development, step 5 is not described in detail.

3.3.1. Step 1. Modeling the system

Step 1 models the system by dividing it into a set of sub-systems (i.e., unit processes, each with a specific purpose) connected together through flows with the environment. A farm is considered the highest-level complex system in the tool. Its function is to produce food based on a specific demand, as represented by Pradel (2011) (Fig. 5).

A farming system includes animal and crop production associated with a fodder system, and the use of agricultural equipment and buildings, inputs (e.g., seeds, fertilizers, pesticides, veterinary products, energy carriers, water) and other materials required to fulfill its function. The scope of this study was limited to typical agricultural equipment used in typical field operations to produce crops. For simplicity, these field operations were divided into six classes according to the classification of Nemecek and Kägi (2007) (Table 3). The hierarchical structure of the high-level complex system retained (the farm), with its focus on crop production, was illustrated (Fig. 6).

In practice, users can select and set up agricultural equipment, inputs and other materials to model the desired crop management, field operation or cropping technique and estimate its environmental impacts. O-AMIE uses two complementary approaches to create models:

- Physical modeling, to reproduce the behavior of the real system as much as possible (Raynal, 2019). It can be based on mechanistic (or dynamic) models, whose equations and principles describe fundamental mechanisms of the system, and/or empirical (or statistical) models, which determines empirical relations using experimental data and statistical methods.

**Table 3**

Simplified definitions of typical field operations for crop production.

Field operation	Short description
Soil cultivation	Preparation of the agricultural field before sowing or planting
Sowing & planting	Planting of seeds or plants
Fertilization	Application of any natural or synthetic material to soil or to plant tissues to supply nutrients for plant growth and development
Pest control	Application of any natural or synthetic material to soil or to plant tissues to manage crop pests OR any other techniques (e.g., biological, mechanical, thermal, acoustic) to manage crop pests
Harvesting	Cutting and collecting the crop
Irrigation	Watering the crop

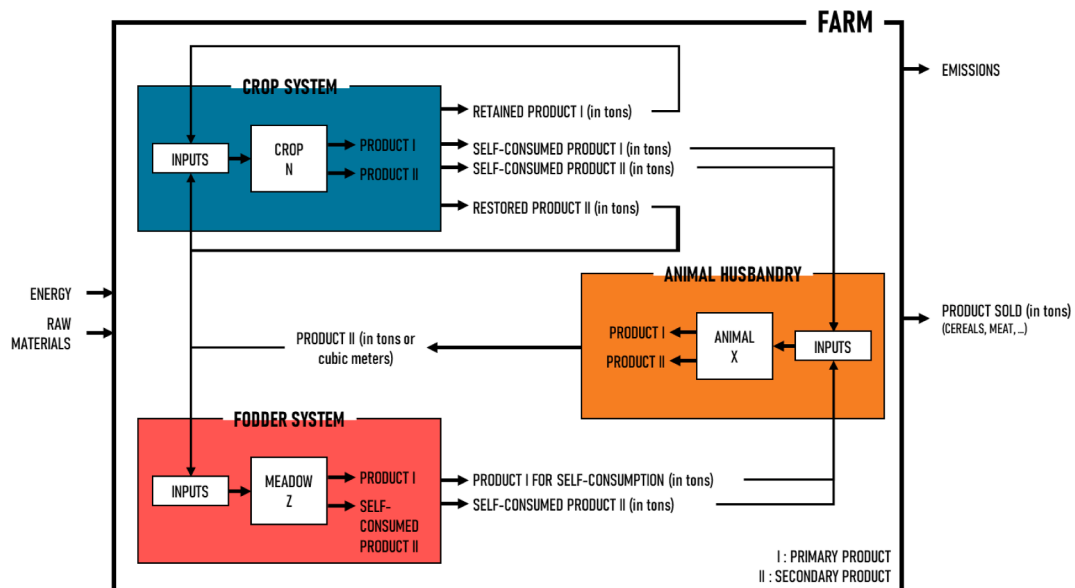

Fig. 5. High-level functional model of a farm.

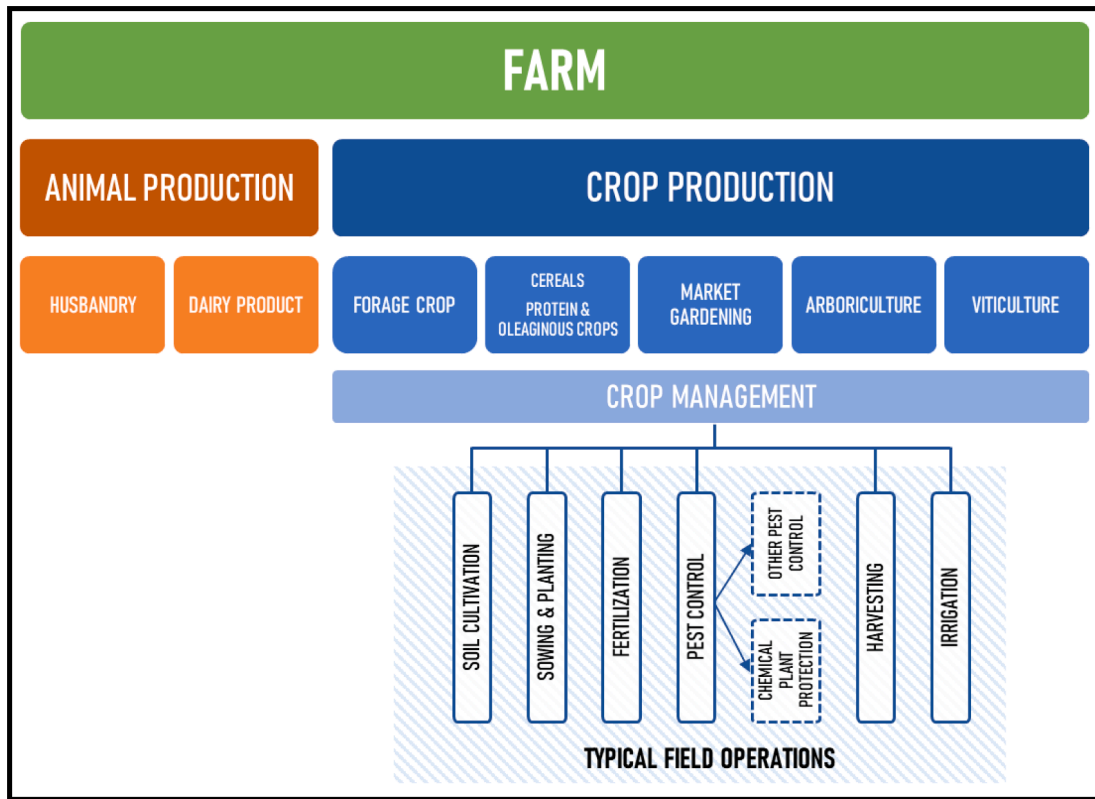

Fig. 6. Hierarchical structure of a farm, with a focus on typical field operations for crop production.

- LCA modeling, to estimate environmental impacts throughout the system’s life cycle (Jolliet et al., 2017). LCA models can be implemented in two ways: generic modeling, in which each component is directly associated with an existing process in the LCA database, and/or precise modeling, in which each component is referenced by its composition (e.g., steel, copper, glass, plastic, rubber).

A hybrid approach can be adopted for a given component by combining mechanistic and empirical modeling to represent physical mechanisms, but generic and precise LCA modeling to calculate indicators of environmental impact.

3.3.2. Step 2. Defining the inventory

Step 2 defines the LCI, which consists of quantifying elementary input and output flows of raw materials and energy throughout the system’s life cycle related to the functional unit (ILCD Handbook, 2010). Two types of data are required:

- Activity data related to the system’s function and characteristics (e.g., kWh consumed, km travelled, t transported).
- Emission factors that estimate the quantity of each emitted material per unit of input (e.g., g NO<sub>x</sub> emitted per L of fuel consumed). Emission factors are required only for specific emissions that depend on the desired level of LCA modeling (e.g., when considering emissions from fuel combustion in agricultural production systems (Nemecek and Kägi, 2007)).

These data can be collected from open-source databases, technical documents, scientific publications, experiments or simulation results of O-AMIE’s physical model of the component. Conventional LCA software or Microsoft Excel® spreadsheets can also be used. If so, interoperability should be ensured between additional software and the tool to keep it simple to use.

3.3.3. Step 3. Estimating impacts

Step 3 performs the LCIA, which consists of estimating potential impacts of the system on the environment based on elementary flows. A characterization method is used to model environmental mechanisms from pollutant emissions to potential damages (i.e., the “impact pathway” or “causal chain”) (ILCD Handbook, 2010; Jolliet et al., 2017). Impacts can be estimated at two points along the impact pathway: midpoint (intermediate impact) and endpoint (final damage). For the midpoint, each elementary flow that contributes to impact category I is converted into impact score S<sub>I</sub> using characterization factor Cf<sub>I,i</sub>, as follows:

$$S_I = \sum_i (m_i \cdot Cf_{I,i}) \tag{1}$$

with  $\begin{cases} S_I : \text{impact score for category } I \\ m_i : \text{unit of material } i \\ Cf_{I,i} : \text{characterization factor for material } i \text{ in category } I \end{cases}$

For the endpoint, each elementary flow that contributes to impact category I and damage category D is converted into damage score S<sub>D</sub> using characterization factor Cf<sub>D,i</sub>, as follows:

$$S_D = \sum_i (m_i \cdot Cf_{D,i}) \tag{2}$$

with  $\begin{cases} S_D : \text{damage score for category } D \\ m_i : \text{unit of material } i \\ Cf_{D,i} : \text{characterization factor for material } i \text{ in category } D \end{cases}$

In practice, impact and damage scores can be calculated by O-AMIE simulations by using LCA models of components. The following midpoint impact categories and endpoint damage categories are usually used in LCIA:



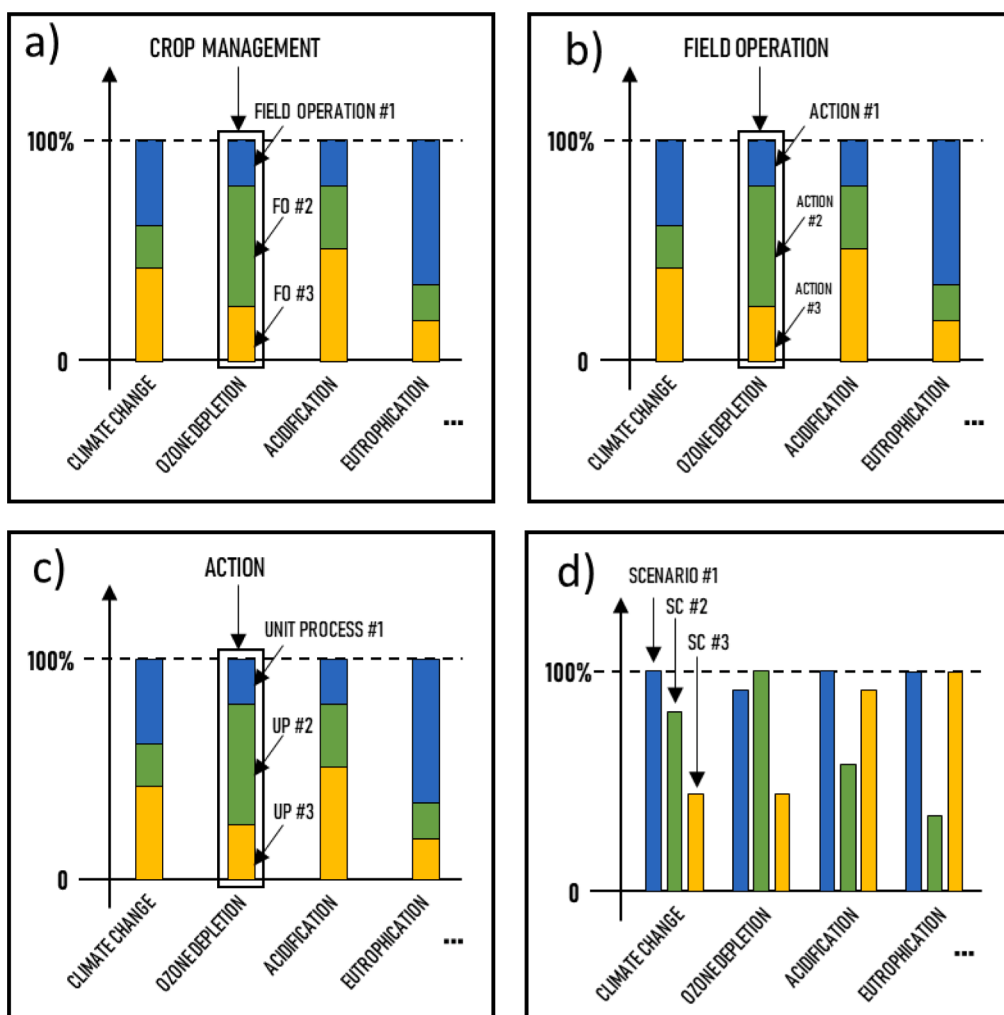

Fig. 7. Illustration of bar graphs showing the system's main contributors to the environmental impacts, depending on the breakdown and comparison desired.

- Impact categories: climate change, ozone depletion (stratospheric), human toxicity, respiratory inorganics, ionizing radiation, (ground-level) photochemical ozone formation, acidification (land and water), eutrophication (land and water), ecotoxicity, land use, resource depletion (minerals, fossil and renewable energy resources, water).
- Damage categories consider three areas of protection: human health (damage to human health), natural environment (damage to ecosystem diversity) and natural resources (resource scarcity).

Optional LCA steps (e.g., normalization, grouping, weighting) can be included in the LCIA to ease interpretation of results by aggregating them into a single score.

#### 3.3.4. Step 4. Processing LCA results

Step 4 processes LCIA results to ease interpretation. Results relative to the functional unit chosen can be displayed in multiple bar graphs:

- The main contributions to all environmental impacts of typical field operations used in the system for a given scenario (Fig. 7a).
- The main contributions to all environmental impacts of actions (e.g., storage, loading, transport, processing) involved in a field operation for a given scenario (Fig. 7b).
- The main contributions to all environmental impacts of unit processes involved in an action for a given scenario (Fig. 7c).

- Comparison of impact or damage scores associated with field operations, actions or unit processes for all scenarios (Fig. 7d).

To increase readability, each impact or damage score is expressed as a percentage of the highest score for the given impact or damage category.

#### 3.3.5. Step 5. Minimizing environmental impacts

Step 5 eco-designs the system by finding optimized system parameters that minimize impacts.

### 4. Conceptual model developed for O-AMIE

This section details only the conceptual model used to perform the EIA function, which is the core of O-AMIE (Fig. 8). Using a Matlab® interface, users can select several scenarios for comparison (step 1) and calculate and interpret their LCA results (steps 4 and 5, respectively). In step 1, users can set up each crop-management scenario by including one or more field operations. Each operation consists of a set of components selected by users from a representative list of existing technical solutions. For simplicity, parameters can be set to default values, while still allowing users to modify them. This selection step is repeated for each scenario to be compared. All input data are grouped into one input file per scenario. In step 4, once all scenarios have been simulated, output data are saved as one output file per scenario. A post-processing step is performed using Matlab® to display results to users, who select

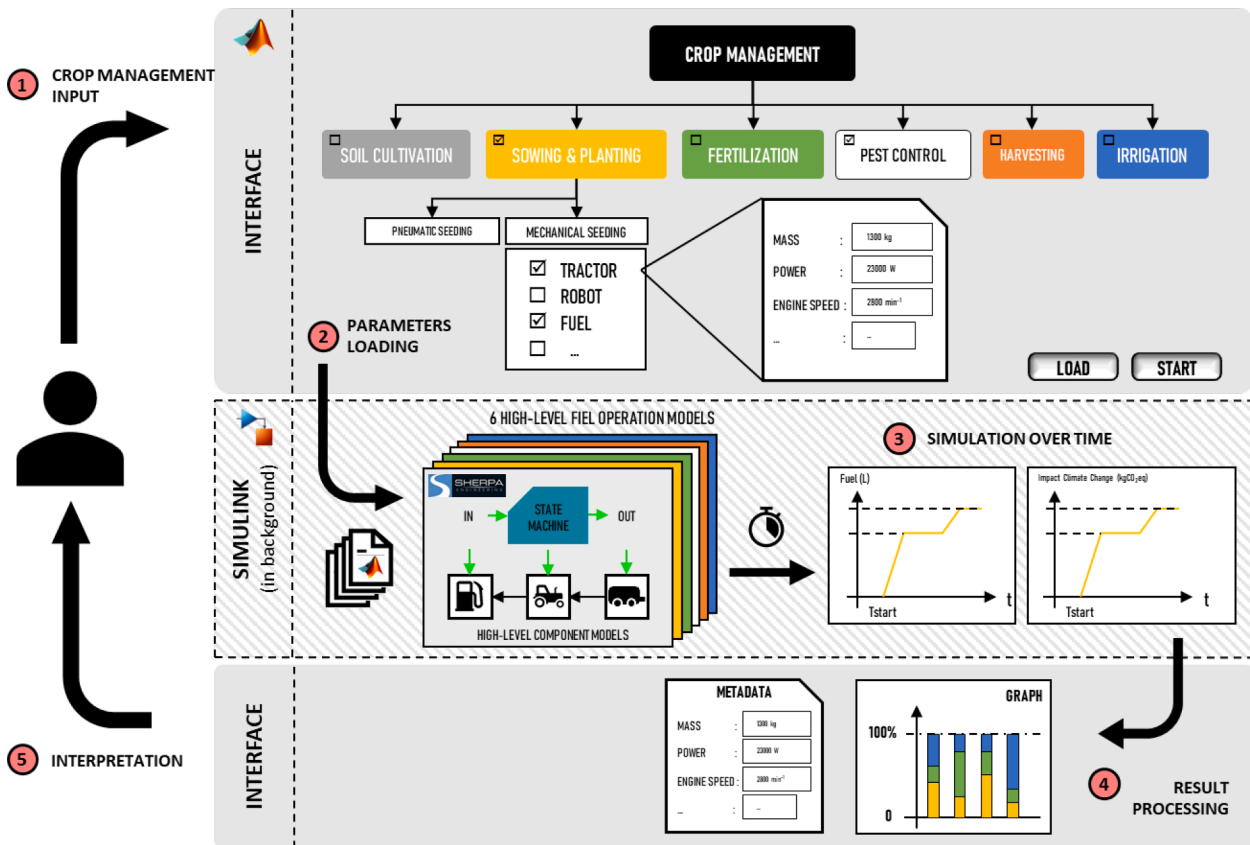

Fig. 8. Conceptual model developed to fulfill the environmental impact assessment (EIA) function.

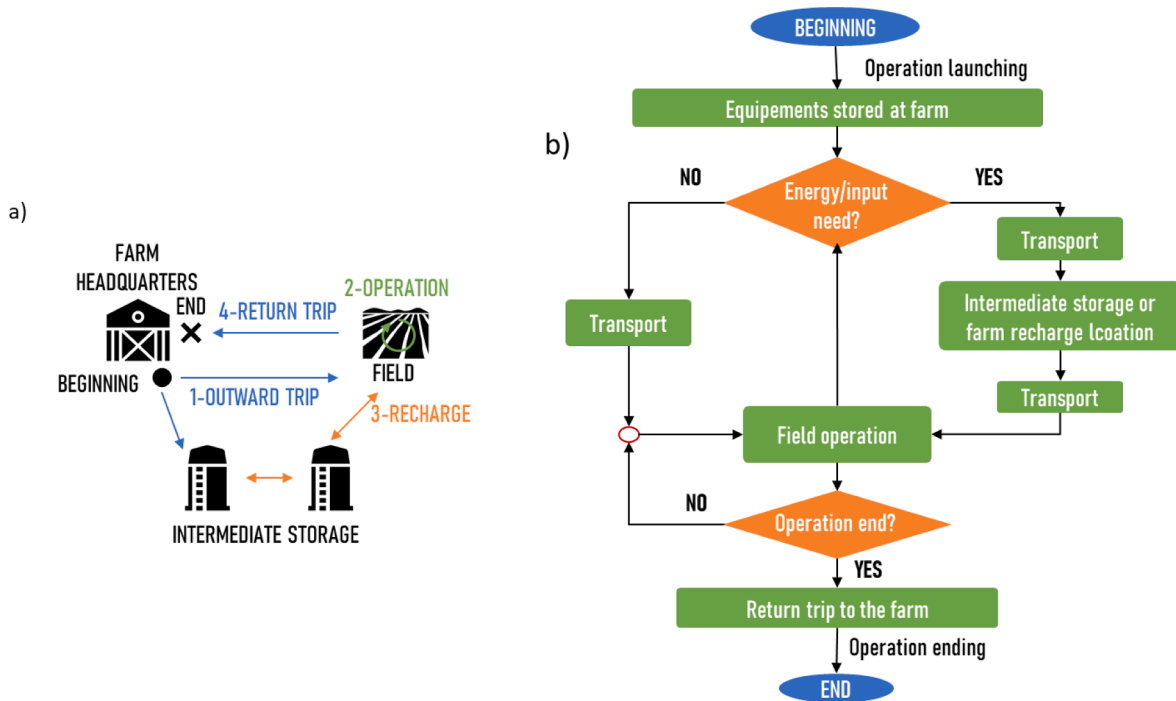

Fig. 9. (a) Predefined cycle and (b) flowchart of a generic sequence for a typical field operation.

which graph(s) to display using the Matlab® interface. Once users have finished the scenarios, all input files that contain the parameters for each required field operation are loaded into corresponding high-level field-operation models (step 2). These models were built using MBD

(described in the next section). This step is performed in the background and is inaccessible to users. Using the interface, users can change the scenario parameters to launch several simulations at once (step 3).

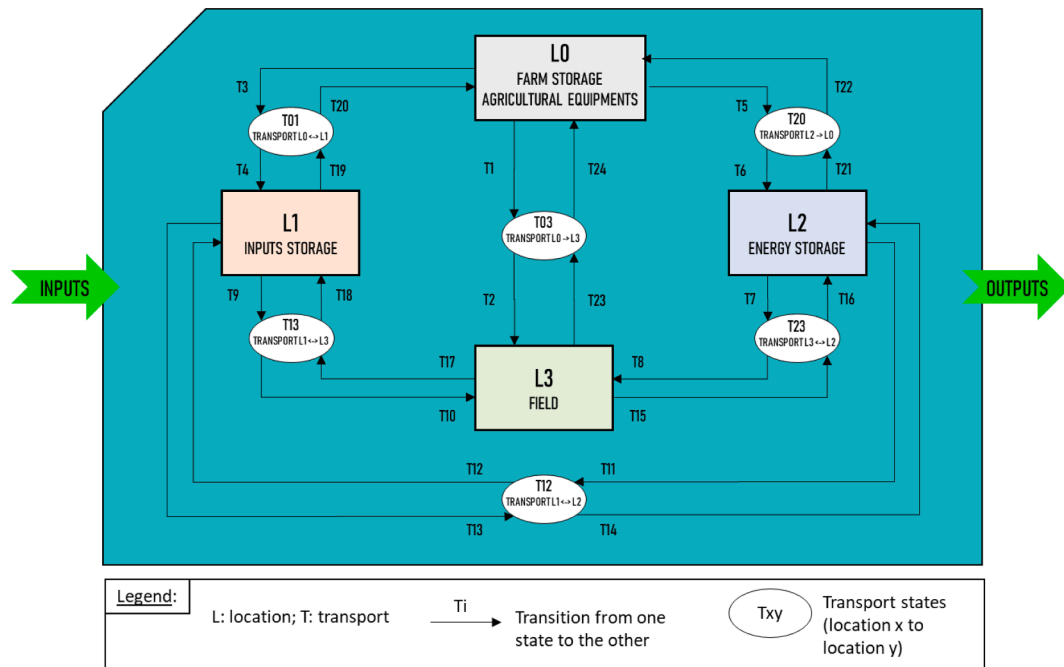

Fig. 10. Diagram of the generic sequencer implemented as a state machine.

Table 4  
 Contents of the physical ( $\Phi$ -DB) and LCA databases (LCA-DB).

Database	Category	Sub-category	Description
$\Phi$ -DB	Agricultural inputs		Products not naturally present in the soil and applied to crops to increase yield
	Agricultural equipment	Building	All types of buildings on a farm
		Traction machine	Machine that can deliver sufficient tractive effort to pull an agricultural tool
		Agricultural tool	Tool attached to a traction machine
		Self-propelled traction machine	Machine that combines a traction machine and an agricultural tool into a single entity
	Energy source		Energy sources and vectors used for field operations
Transport		Equipment used to transport agricultural equipment from one place to another	
Location		Places where operations occur	
LCA-DB	Characterization method		Type of Life Cycle Impact Assessment characterization method
	Emission factor		Factor that describes the amount of substance emitted to the air, water and soil per unit of agricultural input
	Characterization factor		Factor that describes the relative importance of an emitted substance compared to a reference substance for a specific environmental impact category
	Unitary indicator of environmental impact	Generic process Specific process	Process already available in LCA databases Specific process built using generic processes

### 5. MBD approach used to design high-level field-operation models

Both generic and specific approaches were used to model high-level field operations.

#### 5.1. Generic approach used to design high-level field-operation models

The generic crop-management model consists of six high-level field-operation models: tillage, sowing, fertilization, pest control, irrigation and harvesting. The method developed to design each generic high-level field-operation model consisted of the following steps:

- Define a typical sequence (i.e., all actions required to perform the field operation)
- Create a database (i.e., a model library of components related to the field operation)
- Model the components (i.e., equations and parameters used to calculate environmental impacts)

##### 5.1.1. Typical sequence definition

Typical sequences were defined by developing a generic sequencer that could perform all typical sequences of each field operation. Each typical sequence consists of a series of actions performed by the components to perform the field operation. In general, the sequencer assumes that only one set of agricultural equipment can be used at a time to perform the field operation. The operation occurs in four distinct locations according to a predefined cycle (Fig. 9a): an outward trip from equipment storage (farm headquarters or main shed), the field operation, potential recharge of inputs or energy (each one not at the farm headquarters) and a return trip to equipment storage.

For simplicity, equipment is assumed to travel in straight lines. Fields are assumed to be rectangles, with known areas, series of rows of identical length and inter-rows of identical spacing, which are also assumed to be straight lines. Priorities must be ranked to follow a relevant sequence of actions by determining whether the equipment has sufficient inputs and/or energy to perform the operation. These priorities are defined based on the field operations. Similarly, the distances

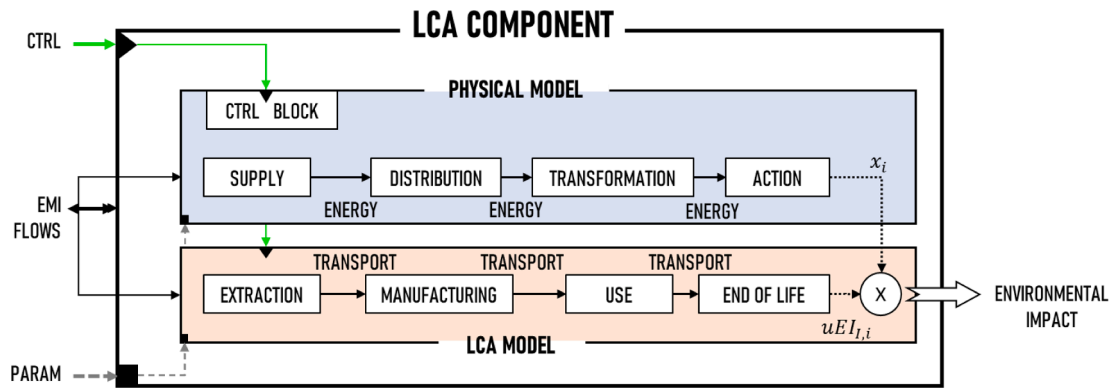

Fig. 11. Generic modeling of an LCA component that combines physical and LCA models.

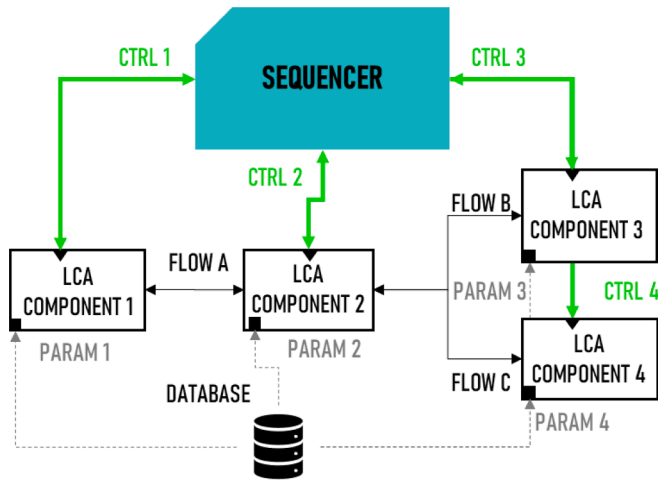

Fig. 12. Generic structure of a high-level field operation model (CTRL: control signal; PARAM: parameters).

between locations are flexible, and can be as short as 0 m, to allow as many configurations as possible (Fig. 9b).

To become operational, this sequence needs to be implemented in a state machine, which describes the state of each component as a function

$$\text{with } \begin{cases} x_i : \text{operational parameter for unit process } i \\ uEI_{l,i} : \text{unitary environmental indicator for impact category } l \text{ and unit process } i \\ EI_l : \text{environmental impact for impact category } l \end{cases}$$

of input variables (energy-material-information (EMI) flows from components). In the state machine, the set of agricultural equipment alternates between a state of actions to be performed depending on its location and a state of transport between these locations. The generic state machine is illustrated, including the four locations and all possible transport states between them (total of 6) (Fig. 10). The transitions between states ( $T_i$ ) (total of 24) are influenced by indicators that depend on the input variables and are specific to each field operation. Each state generates output variables that correspond to component control signals. They then perform precise actions, modifying the system's EMI flows accordingly, and the state machine's input variables then move to another state based on the transitions, and so on until the field operation is completed.

### 5.1.2. Database creation

Two databases were developed to perform the two types of modeling chosen: (i) a “physical” database ( $\Phi$ -DB) containing the physical modeling parameters of the components to couple the SE and LCA approaches and (ii) an LCA database (LCA-DB) containing the LCA modeling parameters of the components (Table 4). These databases were created using object-oriented programming, which enabled elements with similar parameters to be grouped into nested classes and subclasses.

### 5.1.3. Component modeling

The modeling approach used is intended to be generic. It consists of coupling a physical model that reproduces the component's physical behavior as closely as possible with an LCA model that provides unitary indicators of environmental impact (uEI) for its entire life cycle. The generic model of a component is illustrated (Fig. 11).

The component's life cycle is broken down into unit processes to which EMI flows (here, operational parameters ( $x_i$ )) are associated, corresponding to functional units (e.g., mass of tractor (kg), amount of fuel consumed (L)). Multiplying these EMI flows from the physical model by the respective uEI from the LCA model yields the component's total environmental impacts, as follows:

$$EI_l = \sum_{i=1}^n (x_i \cdot uEI_{l,i}) \quad (3)$$

Physical modeling of components is based on functional modeling of a system, which distinguishes the latter's main functions independent of its application. This approach highlights that a system is characterized by progressive transformation of energy through it (i.e., the energy chain), controlled by a control block (i.e., the information chain). The energy chain generally consists of a supply unit that prepares incoming energy for use by the rest of the system, a distribution unit (or pre-actuator) that modulates and distributes energy to actuators based on instructions from the control block, a transformation unit (or actuator/transmitter) that converts distributed energy into mechanical energy (translation or rotation), and then transmits and adapts it into energy usable by the end-effector (energy available for action) and an action unit (or effector) that acts on the component. The operational parameters ( $x_i$ ) are obtained by developing the equations and parameters that control these components using empirical or mechanistic modeling. The

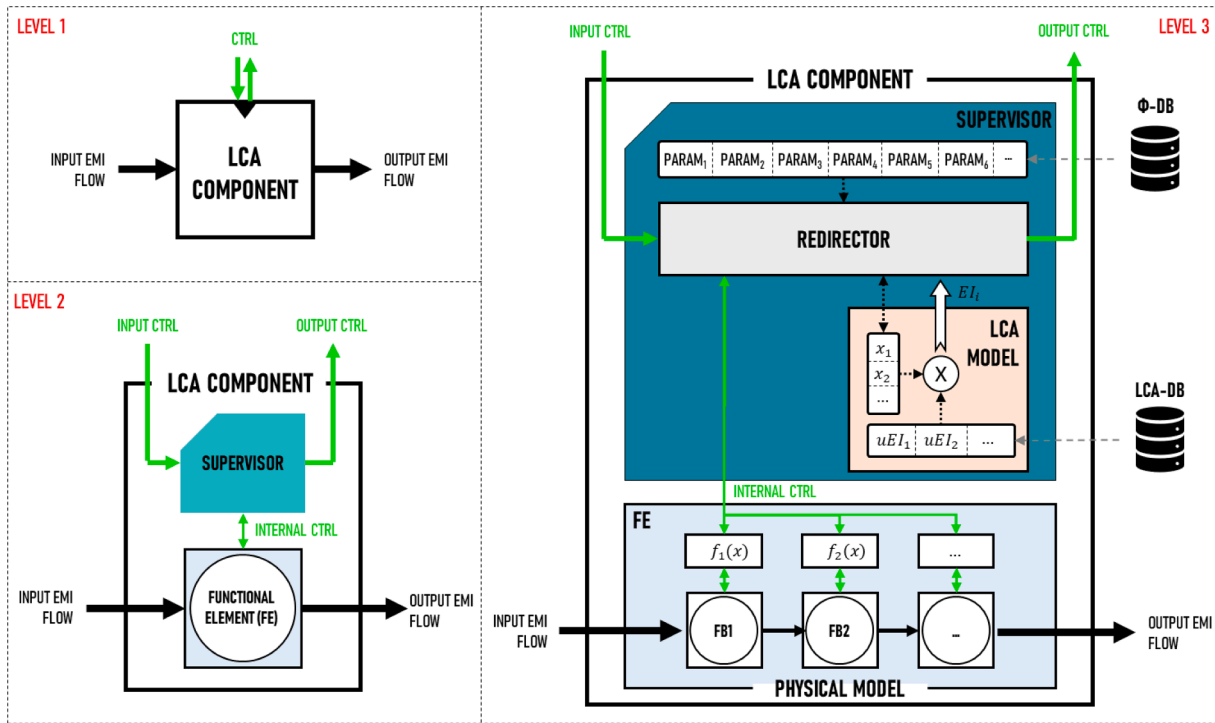

Fig. 13. LCA component architecture divided into three levels: high (level 1), intermediate (level 2) and low (level 3) (CTRL: control signal; FB: functional block; PARAM: parameters, FE: functional element).

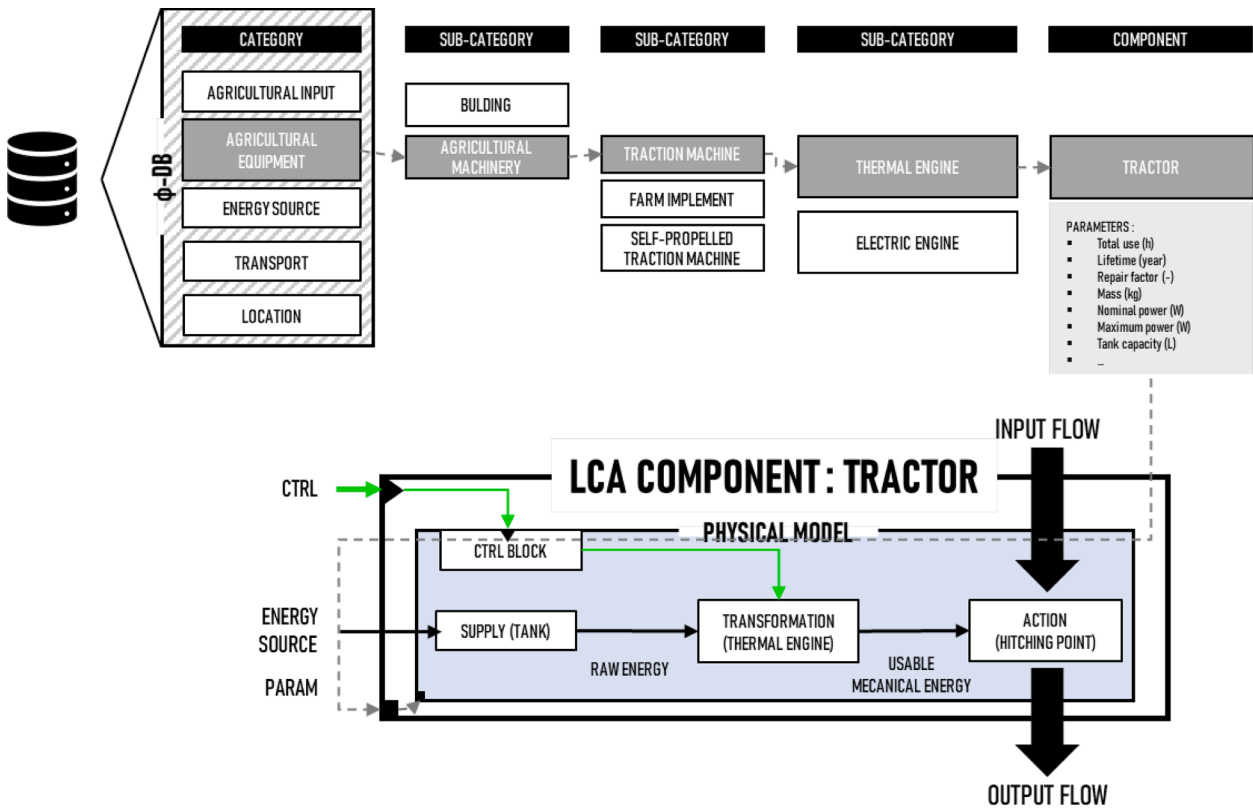
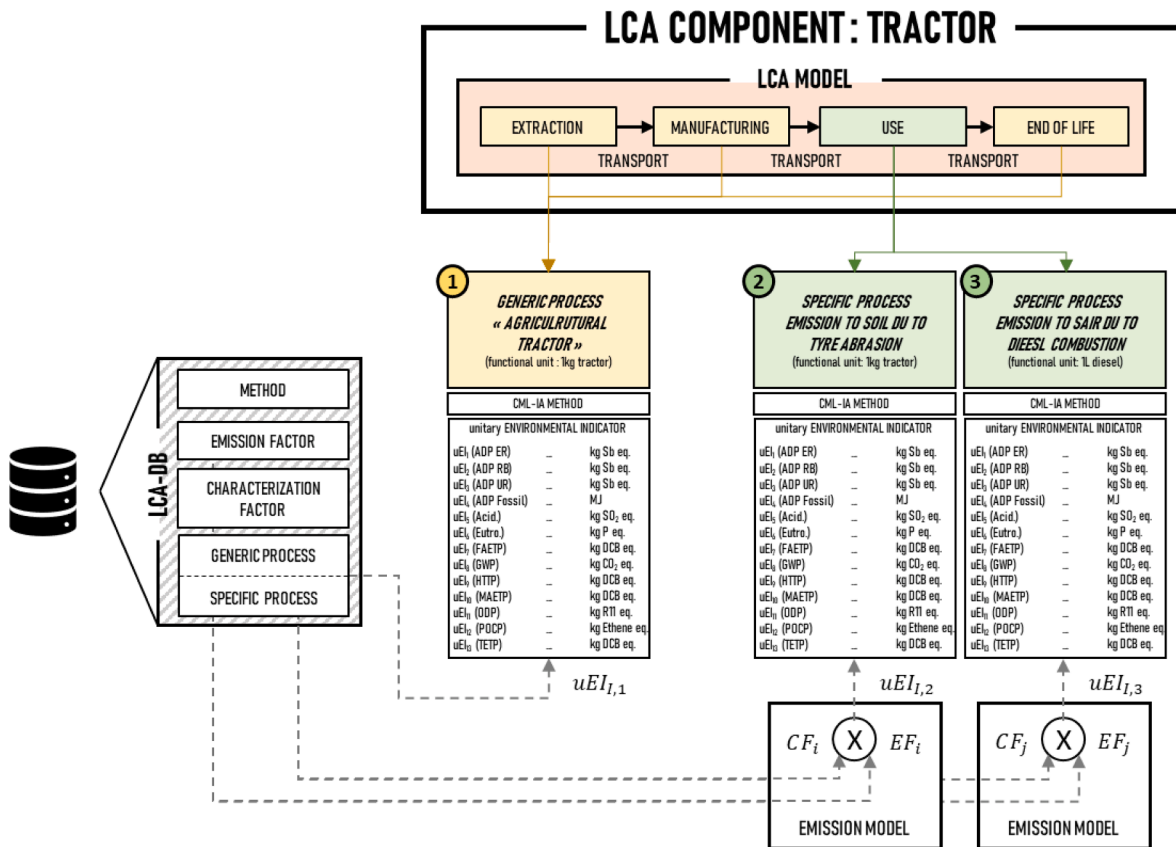

Fig. 14. Physical model of a tractor's LCA component considering a diesel tractor broken down into three functional elements (i.e., tank, diesel engine and a three-point hitch).

values of the parameters in the simulations are then derived from the characteristics of the actual component to be modeled.

LCA modeling consists of breaking down each phase of the compo-

nent's life cycle (i.e., extraction, manufacture, use and end of life) into unit processes. A single unit process can describe several life-cycle phases, and conversely, a life-cycle phase can be described by several



**Fig. 15.** LCA model of a tractor’s LCA component considering a diesel tractor broken down into three processes (a generic process representing the extraction, manufacturing and end-of-life phases, and two emission processes representing the use phase) characterized by the CML-IA method (August 2016) comprising 13 environmental impact indicators (ADP: abiotic resource depletion potential using economic reserves (ER), reserve-based resources (RB) or ultimate reserves (UR); ADP fossil: fossil energy resource depletion potential; Acid.: acidification; Eutro.: eutrophication; FAET: freshwater aquatic ecotoxicity; GWP: Global Warming potential; HTP: Human toxicity potential; MAET: Marine aquatic ecotoxicity, ODP: Ozone depletion potential; POCP: photochemical oxidation potential; TETP: terrestrial ecotoxicity potential, CF: Characterization Factor, E: Emission Factor, uEI: unitary Environmental Impact).

unit processes. The uEI related to these processes are constructed depending on the type of elementary flow that connects them to the ecosphere (i.e., to air, soil and water compartments). For input flows (material and energy flows), the operation consists of directly using the generic and specific processes stored in the LCA-DB and previously extracted from LCA open-access databases from LCA software and/or the literature. For output flows (emissions to the environment), the operation consists of calculating indicators using an emission model obtained from the emission and characterization factors of the substances emitted into the water, air and soil, as follows:

$$uEI_i = \sum_{i=1}^n (EF_i \cdot CF_i) \tag{4}$$

with  $\begin{cases} EF_i : \text{emission factor for substance } i \\ CF_i : \text{characterization factor for substance } i \\ uEI_i : \text{unitary environmental indicator related to impact category } i \end{cases}$

Users can select unit processes to be able to assess many scenarios.

**5.1.4. Implementation of the generic model for high-level field operations**

The generic model for each high-level field operation is implemented by connecting all of the components needed to perform the field operation to each other using different EMI flows and is controlled by a sequencer. This model is also connected to databases that provide the parameters of the physical and LCA models used for the field operation. The typical structure of a high-level field-operation model consists of components (systems that contribute to the field operation), a sequencer (or control block) that controls the components, EMI flows (exchange

flows between components), control signals of components (CTRL) and a database (library that contains component parameters) (Fig. 12).

**5.2. Specific approach used to model high-level field operations**

The specific approach consists of implementing both physical and LCA models of each LCA component using PhiEMI library (Boyer et al., 2022; Mökükü et al., 2020). The architecture of each model is illustrated using the tractor LCA component, as is the implementation of each LCA component to build the high-level field-operation model.

**5.2.1. LCA component-architecture modeling using the PhiEMI library**

The approach used to implement the physical model is based on Sherpa Engineering’s functional modeling principles. Each system can be modeled by combining one or more basic functional blocks (FB). The PhiEMI library of the PhiSim platform provides a set of five FB: a source, a storage, a distributor (a basic FB of the PhiSim library specific to Sherpa Engineering’s functional modeling approach), a transformer and an effector. These blocks are interconnected by EMI flows and driven by a set of control signals. In contrast, the LCA model is implemented using a more conventional approach by relating relevant EMI flows from the databases and the physical model. To ensure a robust, harmonized architecture, the same LCA component structure is used (Fig. 13). Each LCA component architecture is divided into three levels:

- Level 1: the high-level model of the LCA component, considered as an entity that acts on EMI flows

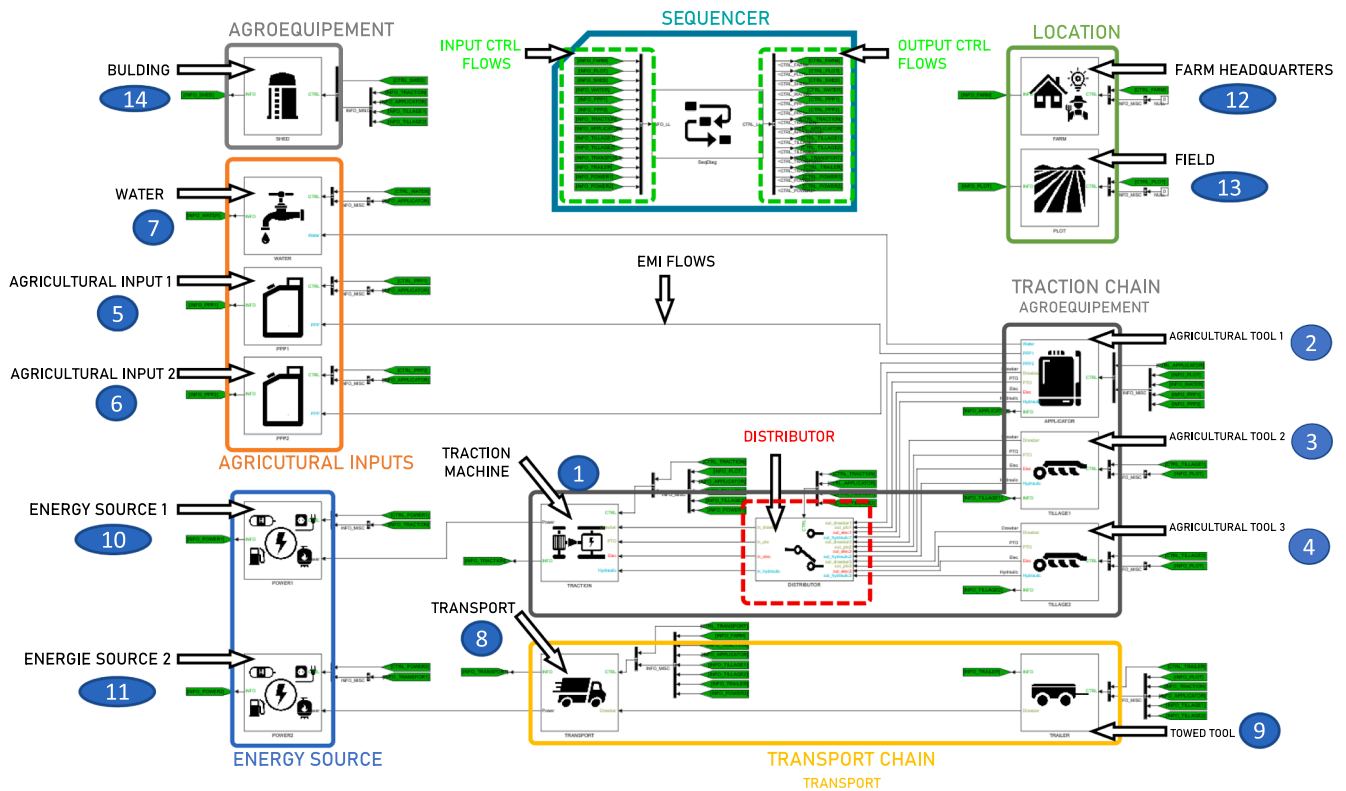

Fig. 16. Modeling a high-level field operation using Simulink®.

- Level 2: an intermediate level, at which the LCA component is a functional element (FE) that describes its physical behavior and is driven by a supervisor via control signals
- Level 3: the low-level model of the LCA component. The FE consists of a set of FBs, each controlled by its own control signals generated by a computational block ( $f_i(x)$ ). The supervisor integrates all physical modeling parameters ( $PARAM_i$ ) from the  $\Phi$ -DB as well as the LCA model, composed of the LCA modeling parameters ( $uEL_i$ ) from the LCA-DB and the operational parameters ( $x_i$ ) from the physical model. The physical and LCA models are illustrated using the example of a tractor (Figs. 14 and 15, respectively). A redirector block is used to redirect control signals to the corresponding entities inside (INTERNAL CTRL) and outside the component (INPUT and OUTPUT CTRL).

The environmental impact results ( $EL_i$ ) of the LCA model are redirected to the sequencer to centralize them and then extracted to O-AMIE's processing space to display graphs.

### 5.2.2. High-level field-operation modeling

Finally, by combining several LCA components, a high-level field-operation model is built using Simulink® (Fig. 16). It consists of a set of 14 LCA components controlled by a sequencer, as follows (numbers in parentheses refer to those in Fig. 16):

- A traction chain that enables the field operation using the component "Traction Machine" (1), which simulates a traction machine (a tractor or a robot) to which up to three components for agricultural tools are connected (2–4). These components can be selected independently to perform the field operations that involve 1–3 tools at a time. The ability to connect three tools provides greater flexibility to implement technical solutions. Agricultural equipment can be connected in three ways: (i) mounted (not supported by the ground), (ii) semi-mounted: (partially supported by the ground) or (iii) trailed (almost completely supported by the ground). In addition, a

distributor is used to redirect flows to the corresponding components, but does not have any modeling function.

- Three components connected to each agricultural tool that represent the agricultural inputs required for the field operation modeled: (i) two "Agricultural inputs" components (5–6), each simulating an input used for the field operation (e.g., seeds, herbicides), and (ii) a "Water" component (7) that represents the volume of water used by the field operation, if necessary (e.g., liquid herbicide). These components can be selected independently, so that up to six agricultural input combinations can be created, depending on the field operation.
- A transport chain that enables farm equipment to be transported, if necessary, using a "Transport" component (8) to which a "Towed tool" component (9) is connected. These components can also be selected, but not independently, since the towed tool requires a transport machine to operate. In contrast, the transport vehicle can operate independently (e.g., automobile, utility vehicle). The traction unit is used directly as a transport unit if the transport chain is not specifically required.
- Two components connected to the traction and transport machines, which represent the energy sources required to power the machines: "Energy Source 1" (10) and "Energy Source 2" (11)
- "Farm Headquarters" (12) and "Field" (13) components that represent the locations where the components operate
- A "Building" component (14) that represents a storage shed

As mentioned, the sequencer component controls components using EMI flows.

### 5.3. Result implementation

Matlab® scripts are used to facilitate case study entry, model initialization, and simulation and extraction of input (model parameters) and output (environmental impacts) data to Matlab®.mat and Excel®.xlsx files. Post-processing is performed rapidly to display impacts in relative value (%) to make the impacts easier to understand,

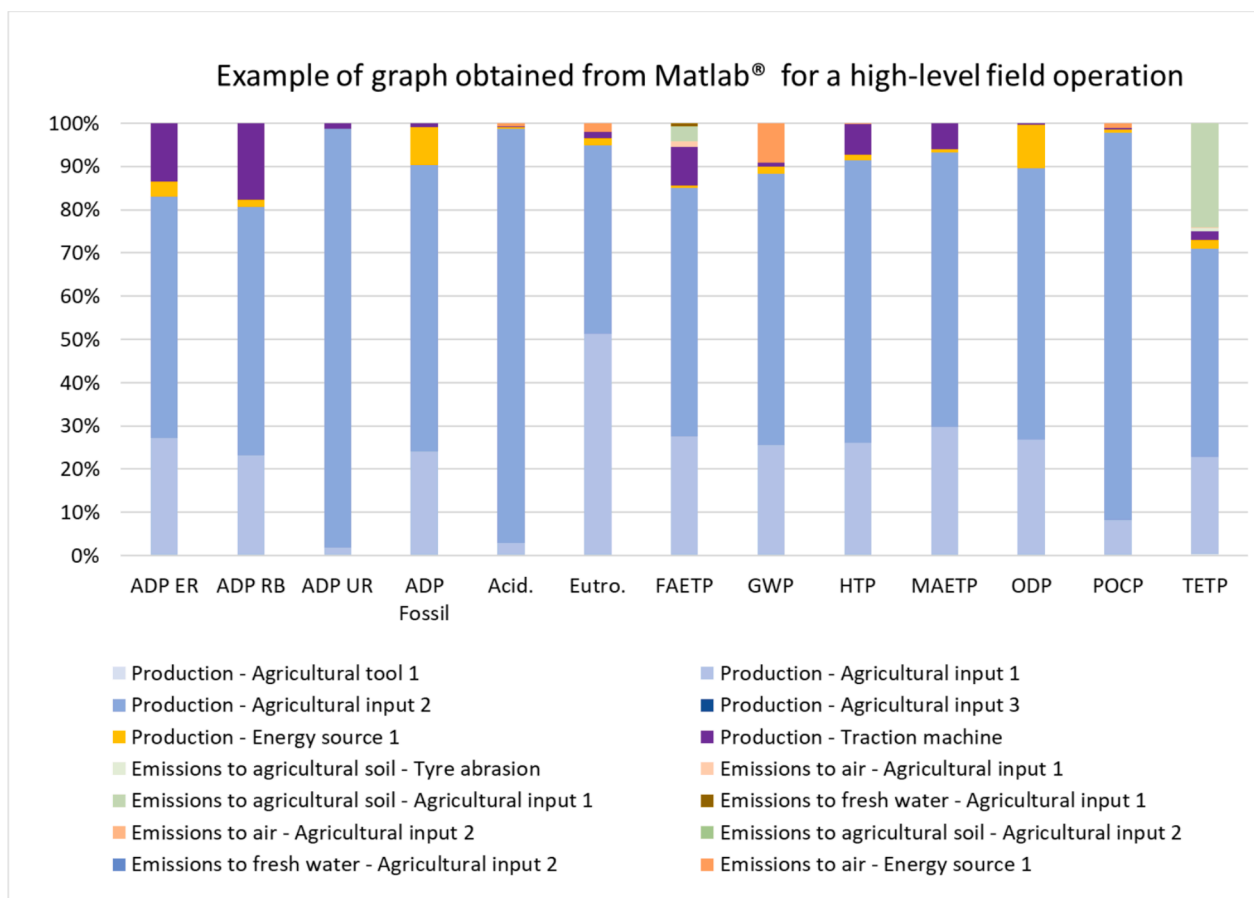

**Fig. 17.** Example of LCA indicators of environmental impact obtained after simulating a high-level field operation (ADP: abiotic resource depletion potential using economic reserves (ER), reserve-based resources (RB) or ultimate reserves (UR); ADP fossil: fossil energy resource depletion potential; Acid.: acidification; Eutro.: eutrophication; FAET: freshwater aquatic ecotoxicity; GWP: Global Warming potential; HTP: Human toxicity potential; MAET: Marine aquatic ecotoxicity, ODP: Ozone depletion potential; POCP: photochemical oxidation potential; TETP: terrestrial ecotoxicity potential).

since the absolute values of impacts differ by several orders of magnitude (i.e., from  $10^{-4}$  kg antimony equivalent for resource depletion to  $10^{+4}$  kg dichlorobenzene equivalent for marine aquatic ecotoxicity). Environmental impacts and contributions of LCA components to them were calculated for a fictive case study as an example (Fig. 17).

## 6. Conclusion

We combined MBSE and LCA to develop an operational tool, O-AMIE, to assess environmental performances and eco-design agricultural field operations. The tool relies on high-level field-operation models implemented using Matlab®/Simulink® software and Sherpa Engineering's PhiSim platform. After developing the tool's functional architecture, a method was developed to design a generic crop-management model composed of six high-level field-operation models, each including all LCA components needed to implement the operation's technical solutions. The method consists of defining a typical sequence, building a database and modeling the LCA components. Each high-level field operation consists of 14 LCA components controlled by a sequencer. The LCA component modeling approach is based on coupling a physical model, which reproduces the physical behavior of the component as closely as possible, with an LCA model, which provides uEIs for the component's entire life cycle. Finally, the sequencer is implemented using a state machine that describes the state of components as a function of their location.

A major benefit of O-AMIE is that it can process many more case

study scenarios in a short period (batch simulation) than conventional LCA software can. It can also perform physical and dynamic modeling, which is not currently possible in LCA software, to eco-design agro-ecological practices, and to optimize costs and environmental impacts of the system throughout its entire life cycle. O-AMIE's main limitation is the need to have access to LCA databases, which sometimes requires access fees.

Currently, O-AMIE simulates two field operations: fertilizer spreading and weeding. Beyond this initial validation study, the tool should be developed in a general way by designing additional field-operation models and integrating them into a generic crop-management model. More specifically, physical models of LCA components, such as internal combustion engines and electric motors, will need to be refined, verified and validated experimentally to model more robust and realistic physical behaviors. A graphical interface also needs to be developed to facilitate input of the scenarios to be studied and interpretation of the environmental impacts calculated. Finally, to complete O-AMIE's functionality, its eco-design function needs to be developed to estimate optimum parameters of the system studied as a function of environmental criteria.

## Funding

This research was financed by the French government IDEX-ISITE initiative 16-IDEX-0001 (CAP 20–25).



## CRedit authorship contribution statement

**Marilys Pradel:** Writing – review & editing, Writing – original draft, Supervision, Project administration, Methodology, Funding acquisition, Conceptualization. **Romain David:** Writing – review & editing, Writing – original draft, Methodology, Conceptualization. **Fabien Gaudin:** Writing – review & editing, Writing – original draft, Methodology, Conceptualization.

## Declaration of competing interest

The authors declare the following financial interests/personal relationships which may be considered as potential competing interests: Marilyns Pradel reports financial support was provided by IDEX-ISITE initiative 16-IDEX-0001. If there are other authors, they declare that they have no known competing financial interests or personal relationships that could have appeared to influence the work reported in this paper.

## Acknowledgments

We thank Jean-Pierre Chanet from INRAE's TSCF research unit for his valuable comments on the manuscript during the writing process. We also thank the two anonymous reviewers for their valuable comments as well as Michael Corson for proofreading the manuscript's English.

## Ethics approval

The article involves no studies on human or animal subjects.

## Data availability

The authors are unable or have chosen not to specify which data has been used.

## References

- Abualtaher, M., Bar, E.S., 2020. Systems engineering approach to food loss reduction in Norwegian farmed salmon post-harvest processing. *Systems* 8 (1), 13.
- Bohm, M.R., Haapala, K.R., Poppa, K., Stone, R.B., Tumer, I.Y., 2010. Integrating life cycle assessment into the conceptual phase of design using a design repository. *J. Mech. Des.* 132, 91005.
- Boyer, B., Fiani, P., Sandou, G., Godoy, E., Vlad, C., 2022. Functional model-based arbitration strategies between system missions: an application to the electric vehicle. In: Gusikhin, O., Madani, K., Zaytoon, J. (Eds.), *Informatics in Control, Automation and Robotics*, volume 793. Springer International Publishing, Cham, pp. 519–543.
- Del Prado, A., Misselbrook, T., Chadwick, D., Hopkins, A., Dewhurst, R.J., Davison, P., Butler, A., Schröder, J., Scholefield, D., 2011. SIMSDAIRY: a modelling framework to identify sustainable dairy farms in the UK. Framework description and test for organic systems and N fertiliser optimisation. *Sci. Total Environ.* 409 (19), 3993–4009.
- Esterman, M., Fumagalli, M.E., Thorn, B., Babbitt, C., Asme, 2012. "A framework for the integration of system engineering and functional analysis techniques to the goal and scope of life cycle assessment". ASME International Design Engineering Technical Conferences/Computers Information in Engineering Conference, Chicago, Illinois, USA.
- Fet, A.M., Schau, E.M., Haskins, C., 2010. A framework for environmental analyses of fish food production systems based on systems engineering principles. *Syst. Eng.* 13 (2), 109–118.
- Fet, A.M., Aspen, D.M., Ellingsen, H., 2013. Systems engineering as a holistic approach to life cycle designs. *Ocean Eng.* 62, 1–9.
- Gadre, S., Esterman, M., Thorn, B.K., and Asme, 2017. "Implementation of an object-oriented life cycle assessment framework using functional analysis and systems engineering principles". ASME International Design Engineering Technical Conferences/Computers and Information in Engineering Conference (IDETC/CIE 2017), Cleveland, Ohio, USA.
- Henderson, K., Salado, A., 2021. Value and benefits of model-based systems engineering (MBSE): Evidence from the literature. *Syst. Eng.* 24 (1), 51–66.
- ILCD Handbook, 2010. "ILCD Handbook: General guide for Life Cycle Assessment - Detailed guidance": 417.
- INCISE, 2023. <https://www.incise.org/systems-engineering>.
- ISO, 2006a. ISO 14040 - Environmental management - Life cycle assessment - Principles and framework.
- ISO, 2006b. ISO 14044 - Environmental management - Life cycle assessment - Requirements and guidelines.
- Jolliet, O., Saadé-Sbeih, M., Crettaz, P., Jolliet-Gavin, N., Shaked, S., 2017. *Analyse du Cycle de Vie – Comprendre et réaliser un écobilan*. Presses Polytechniques et Universitaires Romandes.
- Kossiakoff, A., Sweet, W.N., 2003. *Systems Engineering: Principles and Practices*. Hoboken, NJ, USA, Wiley Online Library.
- Le, Q., Feingold, J., Glandorf, W., Kent, J., Sherman, R., Ferri, J.K., 2023. Model-based systems engineering approaches to chemicals and materials manufacturing. *AIChE J* 69 (8), 24.
- Lindsay, K., Popp, M., Ashworth, A., Owens, P., Burek, J., 2018. A decision-support system for analyzing tractor guidance technology. *Comput. Electron. Agric.* 153, 115–125.
- MathWorks, 2023. "What is Model-Based Design?" Retrieved november 2023, from <http://www.mathworks.com/model-based-design/>.
- Mökükcü, M., Fiani, P., Chavanne, S., Taleb, L.A., Vlad, C., Godoy, E., 2020. "Energy-Based Functional Modelling for Control Architecture Design: An Application to Energy Management for a Hybrid Electric Vehicle." In: Gusikhin, O., Madani, K. (eds) *Informatics in Control, Automation and Robotics*. ICINCO 2017. Lecture Notes in Electrical Engineering, vol 495. Springer, Cham.
- Nemecek, T., Kägi, T., 2007. "Life Cycle Inventories of Agricultural Production Systems". Ecoinvent report No. 15.Dübendorf, Swiss Centre for Life Cycle Inventories: 360 pages. Available at: [https://db.ecoinvent.org/reports/15\\_Agriculture.pdf](https://db.ecoinvent.org/reports/15_Agriculture.pdf).
- Notarnicola, B., Sala, S., Anton, A., McLaren, S.J., Saouter, E., Sonesson, U., 2017. The role of life cycle assessment in supporting sustainable agri-food systems: A review of the challenges. *J. Clean. Prod.* 140, 399–409.
- OECD, 2023. "Better policies to improve the environmental performance of the agriculture sector." Retrieved November 2023, from <https://www.oecd.org/agriculture/topics/agriculture-and-the-environment/>.
- Pradel, M., 2011. L'analyse du cycle de vie à l'échelle d'une exploitation agricole : méthode et premiers résultats. *Sciences, Eaux et Territoires* 4, 40–46.
- Raynal, H., 2019. "Modèles et interopérabilité des modèles." *Cahier des Techniques de l'INRA*: 12.
- Rotz, C.A., Corson, M.S., Chianese, D.S., Montes, F., Hafner, S.D., Bonifacio, H.F., Coiner, C.U., 2022. *The Integrated Farm System Model – reference manual, version 4.7*. Pasture Systems and Watershed Management Research Unit, Agricultural Research Service, United States Department of Agriculture, University Park, PA, USA. 253 pages. Available online: <https://www.ars.usda.gov/ARSUserFiles/80700500/Reference%20Manual.pdf>.
- Sala, S., McLaren, S.J., Notarnicola, B., Saouter, E., Sonesson, U., 2017. In quest of reducing the environmental impacts of food production and consumption. *J. Clean. Prod.* 140, 387–398.
- Schils, R.L.M., Olesen, J.E., del Prado, A., Soussana, J.F., 2007. A review of farm level modelling approaches for mitigating greenhouse gas emissions from ruminant livestock systems. *Livest. Sci.* 112, 240–251.
- Smith, S.A., Popp, M.P., Keeton, D.R., West, C.P., Coffey, K.P., Lanier Nalley, L., Brye, K.R., 2016. Economic and Greenhouse Gas Emission Response to Pasture Species Composition, Stocking Rate, and Weaning Age by Calving Season, Farm Size, and Pasture Fertility. *Agricultural and Resource Economics Review* 45/1 (April 2016) 98–123.