



HAL
open science

Evaluation of risks and monitoring of nitrogen fluxes at the crop level on the Romanian and Bulgarian plain. Application to maize, wheat, rapeseed and sugar beet

B. Leviel

► **To cite this version:**

B. Leviel. Evaluation of risks and monitoring of nitrogen fluxes at the crop level on the Romanian and Bulgarian plain. Application to maize, wheat, rapeseed and sugar beet. Life Sciences [q-bio]. Institut National Polytechnique, 2000. English. NNT: . tel-02839538

HAL Id: tel-02839538

<https://hal.inrae.fr/tel-02839538v1>

Submitted on 7 Jun 2020

HAL is a multi-disciplinary open access archive for the deposit and dissemination of scientific research documents, whether they are published or not. The documents may come from teaching and research institutions in France or abroad, or from public or private research centers.

L'archive ouverte pluridisciplinaire **HAL**, est destinée au dépôt et à la diffusion de documents scientifiques de niveau recherche, publiés ou non, émanant des établissements d'enseignement et de recherche français ou étrangers, des laboratoires publics ou privés.



THESE

Présentée pour obtenir

LE TITRE DE DOCTEUR DE L'INSTITUT NATIONAL POLYTECHNIQUE DE TOULOUSE

SPECIALITE: SCIENCE DE L'EAU ET ENVIRONNEMENT

Par

Bruno LEVIEL

Ingénieur ENSEEIHT

**Evaluation des risques et maîtrise des flux d'azote au niveau d'une
parcelle agricole dans la plaine roumaine et bulgare. Application
aux cultures de maïs, blé, colza et betterave.**

*Evaluation of risks and monitoring of nitrogen fluxes at the crop
level on the Romanian and Bulgarian plain. Application to maize,
wheat, rapeseed and sugar beet.*

Soutenue le 30 MAI 2000 devant le jury composé de:

M. Lucien Masbernat
Professeur à l'INP Toulouse

Président

M. André Falisse
Professeur à Gembloux, Belgique

Rapporteur

M. Nader Katerji
Directeur de recherche à l'INRA de Grignon

Rapporteur

M. Ghislain Gosse
Directeur de recherche à l'INRA de Grignon (directeur de la thèse)

M. Michele Genovese
Docteur, Commission Européenne

Abstract

Environment has become a major concern all over Europe, notably regarding non-point source pollution from agriculture. Not only groundwater but also rivers and seas are subject to nitrogen and other compounds fluxes linked to agricultural productions, and their impact on environmental factors as drinking water quality, toxicity or biodiversity.

Because of economic reasons, these questions are not yet priorities in eastern Europe. However, the Bulgarian and Romanian plains, which constitute the Danube's terminal watershed with the Black Sea as outlet, need actions as this project promoted by EC.

The aim was to develop and apply a methodology in country-specific conditions in co-operation with local searchers. The results expected were recommendations to local agriculture and maintain of research and development potential of eastern Europe partners.

Typical situations were defined from information about the most common crops and soils. Modelling of the Soil-Plant System was then used as a second step to extrapolate typical situations to regional situations. To that end, a first series of experiments was performed to calibrate the model parameters. An *in situ* model validation was performed with independent series of experiments. From these models, both a risk evaluation and an identification of sensitive zones was done in relation to the current agricultural practices. An analysis based on long-term climatic records was used. It aimed at developing sustainable agricultural techniques suited to the site-specific characteristics.

The results are an estimation of the risk level and a definition of the means to reduce nitrogen percolation downwards into deep ground water and/or rivers.

Résumé

L'environnement est devenu une préoccupation majeure dans toute l'Europe, particulièrement en ce qui concerne les pollutions agricoles diffuses. Les eaux souterraines mais aussi rivières et mers sont exposées aux flux d'azote et autres composés liés aux productions agricoles, et à leur impact sur les facteurs environnementaux tels la qualité de l'eau potable, la toxicité ou la biodiversité.

Pour des raisons économiques, ces questions ne sont pas encore prioritaires en Europe de l'Est. Pourtant, les plaines bulgares et roumaines qui constituent le bassin versant terminal du Danube avec la Mer Noire comme exutoire nécessitent des actions comme ce projet financé par l'UE.

L'objectif était de développer et appliquer, dans les conditions de ces pays, une méthodologie spécifique en coopération avec les chercheurs locaux. Les résultats escomptés étaient des recommandations pour l'agriculture locale et le maintien du potentiel de recherche et développement des pays de l'Est partenaires.

Des situations types ont été définies à partir d'informations concernant les cultures et sols les plus fréquemment rencontrés. La deuxième étape a été l'utilisation de modèles de cultures pour extrapoler les résultats des situations types à une échelle régionale. Pour cela, une première série d'expérimentations a été réalisée pour caler les paramètres des modèles. Une validation *in situ* des modèles a été faite, basée sur des données expérimentales indépendantes. A partir de ces modèles, l'évaluation des risques et l'identification des zones sensibles sera menée pour les itinéraires techniques existants. Une analyse sur une longue série climatique a été utilisée. L'objectif était d'élaborer des itinéraires techniques "propres" adaptés aux particularités des sites.

Les résultats sont une estimation des niveaux de risque et la définition de recommandations visant à réduire les pertes d'azote vers les eaux souterraines ou de surface.

Table of contents

ABSTRACT.....	1
RÉSUMÉ	1
TABLE OF CONTENTS.....	2
INTRODUCTION	6
1. BACKGROUND.....	7
1.1. SUSTAINABLE MANAGEMENT AND QUALITY OF WATER	7
1.1.1. <i>Implications for society</i>	7
1.1.2. <i>Implications for the economy</i>	7
1.1.3. <i>Implications for Europe</i>	8
1.2. BLUE DANUBE AND BLACK SEA	8
1.3. RECENT STUDIES ABOUT THE BLACK SEA POLLUTION	9
1.4. EASTERN EUROPE: ECONOMY AND SITUATION OF RESEARCH AND DEVELOPMENT.....	11
1.5. ROMANIA.....	12
1.6. BULGARIA	12
2. OBJECTIVES OF THE STUDY	13
2.1. DEFINITION OF STUDIES	13
2.1.1. <i>Regions and soils</i>	13
2.1.2. <i>Crops and models</i>	13
2.2. SIMULATIONS OF DIFFERENT CLIMATES AND TECHNIQUES.....	14
2.3. RISKS ANALYSIS AND RECOMMENDATIONS.....	15
2.4. TRANSFER OF TECHNOLOGY TO LOCAL SEARCHERS.....	15
2.4.1. <i>Exchanges</i>	15
2.4.2. <i>Formation</i>	15
2.4.3. <i>Equipment</i>	18
3. DESIGN.....	19
3.1. EXPERIMENTAL SITES	19
3.1.1. <i>Choice of crops</i>	19
3.1.2. <i>Typology of regions next to the Danube River</i>	20
3.1.3. <i>Definition of typical situations</i>	20
3.2. MODELS.....	21
3.2.1. <i>Choice of models</i>	21
3.2.2. <i>Improvement of models</i>	22
3.2.3. <i>Models calibration</i>	23
3.3. SIMULATIONS	23
3.3.1. <i>Weather data sets and scenarios</i>	23
3.3.2. <i>Analysis of risks linked to climate and/or techniques</i>	24
3.3.3. <i>Recommendations</i>	24
4. CERES-BEET DEVELOPMENT AND BIBLIOGRAPHY.....	25
4.1. BIBLIOGRAPHY	25
4.1.1. <i>Sowing</i>	25
4.1.2. <i>Emergence</i>	25
4.1.3. <i>Heterogeneousness</i>	26
4.1.4. <i>Early growth</i>	26
4.1.5. <i>Base temperature</i>	27
4.1.6. <i>Leaves development</i>	28
4.1.7. <i>Dry matter accumulation</i>	29
4.1.8. <i>Root development</i>	31
4.2. LAI.....	32
4.2.1. <i>Materials and methods</i>	32
4.2.2. <i>Results</i>	36
4.2.3. <i>Discussion</i>	41
4.2.4. <i>Conclusion</i>	47

4.3.	CERES-BEET	47
4.3.1.	Construction	47
4.3.2.	Calibration and validation	47
4.3.3.	Perspectives.....	50
5.	MODELS UPDATE	51
5.1.	PHYSICAL BASES	51
5.1.1.	Soil water	52
5.1.2.	Soil nitrogen	53
5.1.3.	Crop	54
5.2.	PROGRAM STRUCTURE.....	55
5.2.1.	Inputs.....	55
5.2.2.	Outputs	56
5.2.3.	Global flow diagram	57
5.3.	UTILISATION.....	58
5.3.1.	Parameterisation.....	58
5.3.2.	Global interfacing with Excel.....	62
5.3.3.	Input parameters management.....	64
5.3.4.	Outputs visualisation.....	65
5.3.5.	Simulation of crops rotations	68
5.4.	MODIFICATIONS WITHIN THE PROJECT AND LIMITS	69
5.4.1.	Bare soil functioning	69
5.4.2.	Input/output files	70
5.4.3.	Management of different crop models.....	71
5.4.4.	Limits.....	71
5.5.	CONCLUSION	72
6.	CALIBRATION OF EXPERIMENTAL CONDITIONS.....	73
6.1.	BOJURISHTE (WHEAT)	73
6.1.1.	Experiment description	73
6.1.2.	Measurements	73
6.1.3.	Treatments and replicates	73
6.1.4.	Results synthesis.....	73
6.1.5.	CERES model calibration	74
6.1.6.	Model validation	77
6.1.7.	Utilisation for one crop and bare soil	79
6.2.	CHELOPECHENE (MAIZE).....	80
6.2.1.	Experiment description	80
6.2.2.	Measurements	81
6.2.3.	Treatments and replicates	81
6.2.4.	Results synthesis.....	81
6.2.5.	CERES model calibration	83
6.2.6.	Model validation	87
6.2.7.	Utilisation for one crop and bare soil	89
6.3.	FUNDULEA (WHEAT)	91
6.3.1.	Experiment description	91
6.3.2.	Measurements	92
6.3.3.	Treatments and replicates	92
6.3.4.	Results synthesis.....	92
6.3.5.	CERES model calibration	93
6.3.6.	Model validation	95
6.3.7.	Utilisation for one crop and bare soil	96
6.4.	FUNDULEA (MAIZE).....	98
6.4.1.	Treatments and replicates	98
6.4.2.	Results synthesis.....	98
6.4.3.	CERES model calibration	99
6.4.4.	Model validation	100
6.4.5.	Utilisation for one crop and bare soil	102

6.5.	BUCHAREST (SUGAR BEETS).....	105
6.5.1.	<i>Experiment description</i>	105
6.5.2.	<i>Measurements</i>	105
6.5.3.	<i>Treatments and replicates</i>	105
6.5.4.	<i>Results synthesis</i>	105
6.5.5.	<i>CERES model calibration</i>	107
6.5.6.	<i>Model validation</i>	108
6.5.7.	<i>Utilisation for one crop and bare soil</i>	109
6.6.	DATA BASE.....	111
6.6.1.	<i>Description</i>	111
6.6.2.	<i>Perspectives</i>	112
7.	RESULTS OF AGRICULTURAL SYSTEMS' TYPOLOGY	114
7.1.	PRINCIPLE AND OBJECTIVES.....	114
7.2.	SITUATION IN ROMANIA	114
7.2.1.	<i>Zones studied</i>	114
7.2.2.	<i>Soils description</i>	115
7.2.3.	<i>Meteorological data</i>	119
7.2.4.	<i>Farming systems and practices</i>	120
7.3.	SITUATION IN BULGARIA	125
7.3.1.	<i>Zones studied</i>	125
7.3.2.	<i>Soils description</i>	125
7.3.3.	<i>Meteorological data</i>	127
7.3.4.	<i>Farming systems and practices</i>	129
7.4.	OTHER USEFUL DATA.....	132
8.	MODELS UTILISATION	133
8.1.	PRINCIPLE AND OBJECTIVES.....	133
8.2.	METHOD	134
8.3.	ROMANIA.....	134
8.3.1.	<i>Translation into scenario</i>	134
8.3.2.	<i>Risk analysis</i>	136
8.3.3.	<i>Conclusion</i>	154
8.4.	BULGARIA	154
8.4.1.	<i>Translation into scenario</i>	154
8.4.2.	<i>Risks analysis</i>	155
8.4.3.	<i>Conclusion</i>	160
8.5.	SOFTWARE IMPROVEMENT TO PERFORM RISK ANALYSIS.....	160
9.	LIMITS, RECOMMENDATIONS AND PERSPECTIVES	162
9.1.	RECOMMENDATIONS TO RESEARCH	162
9.1.1.	<i>Increasing the quantity of data</i>	162
9.1.2.	<i>Improving the quality of data</i>	162
9.1.3.	<i>Integrating the existing specialities knowledge and know-how</i>	163
9.1.4.	<i>Improvement of models</i>	163
9.2.	RECOMMENDATIONS TO AGRICULTURE	163
9.2.1.	<i>Risks through leaching</i>	164
9.2.2.	<i>Risks through surfaces flows</i>	164
9.2.3.	<i>Recommendations</i>	164
9.3.	PERSPECTIVES.....	166
	CONCLUSION.....	167
	REFERENCES	169
	INDEX OF FIGURES	167
	INDEX OF TABLES	179
	INDEX OF APPENDICES.....	180

I thank all my colleagues in INRA for their co-operation, help or assistance, and particularly Dr. Raymond Bonhomme, ex-director of the ex-Bioclimatology station of Grignon.

I especially thank Dr. Ghislain Gosse for his confidence for several years concerning this thesis and the other interesting projects in which he involved me, and Mrs Françoise Flament who solved every administrative problem with an incomparable efficiency.

I have a special thought to the persons involved in the project that supported my work:
COPERNICUS project (Project IC15CT96-0101) partners:

Dr. Ghislain Gosse (Co-ordinator)
Françoise Flament
Dr. Benoît Gabrielle
Dr. Romain Roche
Institut National de la Recherche Agronomique
Unité Environnement et Grandes Cultures - Thiverval-Grignon (France)

Prof. André Falisse
Xavier Cocu
Faculté des Sciences Agronomiques de Gembloux (Belgique)

Prof. Lucian Ghinea
Dr. Catalin Lazar
Research Institute for Cereals and Industrial Crops Fundulea (Romania)

Assoc. Prof. Dr. Zornitsa Popova
Scientific researcher Dr. Totka Mitova
Scientific researcher Milena Kersheva
Prof. Dr. Ivan Varlev
N. Poushkarov Soil Science Institute of Sofia (Bulgaria)

Dr. Cecilia Crivineanu
Dr. Marin Dumbrava
Université des Sciences Agronomique et de Médecine Vétérinaire de Bucarest (Roumanie)

Fortunately, work is not everything in life. I salute all my sport-addicted friends, mainly runners but also bikers and so on. Together, we had many painful experiences, always with the same satisfaction, for all of us, after the race ! See you soon Jean-Baptiste, Olivier, Christian, Pierre, Vincent, François-Xavier, Virginie, Nicolas, Sophie.

To my wife,
A mon épouse.

Introduction

The European Community countries' ecological experience has emphasised the necessity of anticipating all environmental problems, notably regarding non-point source pollution from agriculture in large-scale farming industry. The nitrogen fluxes linked to agricultural productions, and their impact on drinking water quality, necessitate action in such zones as the Bulgarian and Romanian plains, which constitute the Danube's terminal watershed, with the Black Sea as outlet.

Firstly, the study of "typical" situations, that is to say the most common crops and soils, allows an estimation of the risk level and a definition of the means to reduce nitrogen percolation downwards into deep ground water and/or rivers.

Modelling of the Soil-Plant System can be used as a second step to extrapolate "typical" situations to regional situations. To that end, a first series of experiments was performed to calibrate the model parameters. The *in situ* model validation was performed with independent series of experiments.

From these models, both a risk evaluation and an identification of sensitive zones was done in relation to the current agricultural practices. A frequential analysis based on long-term climatic records was used. It aimed at developing sustainable agricultural techniques suited to the site-specific characteristics.

1. Background

For a few years, and with the recent events in western Europe (pollution of water and air, global warming and its effects on climate), environment has become a major preoccupation for people and political deciders. If local point-source emissions, mainly from industry, might be more easily regulated, non-point-source emissions, especially from agriculture, will certainly remain hard to measure and to restrain. Scientists have pointed out this problem for long, and tools are available to deal with non-point-source emissions. The difficulty consists in the variability induced simultaneously by the climate, the type of soil, and the crop cultivated. Direct measurements can be performed, but they are time-consuming and expensive, and correspond, after one season or one year of measurements, to one combination climate/soil/crop, and therefore these measurements cannot be extrapolated, neither to another place, nor to another crop, nor to another year. The solution proposed by searchers in environment and agriculture is the use of mechanistic crop models. They describe the soil-plant-atmosphere interactions for physical transfers in soil and crop development, in function of the climate. So, if such interactions are well simulated, results can be extrapolated to any combination of soil and crop, and submitted to various climates to determine risks of pollution. From these risk analyses, recommendation can be done to farmers or regional deciders for agriculture, in order to reduce environmental risks linked to crop production.

Such a scenario is natural in western Europe. Unfortunately, the situation is different in eastern Europe. Indeed the means required for modelling techniques limit the use of this tool in countries like Romania and Bulgaria, two countries with important agricultural productions along the Danube river with the Black Sea as outlet. It is mainly an economic problem, that should disappear with time, but there is also a lack in Research and Development in this domain. EU sustains the co-operation of western and eastern countries to fill in the gap in research of the latter.

1.1. Sustainable management and quality of water

1.1.1. Implications for society

A vital natural resource, water continues to be wasted and treated with little respect - despite its economic importance. Since 1970, the quantity of water available per human being has dropped by 40% and two out of five people living on the planet have water supply problems. This imbalance between needs and availability is leading to over-exploitation, the depletion of reserves and consequently to tensions between competing users, or even countries.

It is not only the southern countries of the world which are under threat. 60% of Europe's cultivated land contains fertiliser and pesticide levels which are dangerous to the quality of groundwater. The combined effect of peak water demand due to tourism and irrigation is also producing a worrying depletion of water reserves in some southern Member States.

1.1.2. Implications for the economy

In Europe, domestic water consumption represents just one fifth of total consumption; 54% is consumed by industry and 26% by agriculture. The cost of supplying the EU with water almost doubled between 1990 and 1995 (from 12 to 20 billion euros) and is expected to reach 30 billion euros in the year 2000. The global water market - in which Europe possesses leading know-how, particularly in building and managing water treatment plants - is expected to reach 124 billion euros in 2010.

1.1.3. Implications for Europe

Twenty European countries depend on the rivers of neighbouring Member States for more than 10% of their water supplies - and for as much as 75% in the case of the Netherlands and Luxembourg. This is why EU Member States have adopted a common water policy, implemented through directives designed to protect this shared resource. The "Urban waste water" directive, for example, requires all agglomerations of between 10000 and 15000 inhabitants to be served by an adequate water collection and treatment system by the year 2005.

1.2. Blue Danube and Black Sea

Connecting eight countries from the Black Forest to the Black Sea, the Danube is Europe's second longest river (Figure 1). The Danube River Basin covers 817 000 km² in 17 countries in the heart of Central Europe. The cumulative inflow of nutrients to the Danube River system is causing eutrophication problems in the river itself and pollution of its groundwater, as well as adding to the degradation of the unique Danube delta and the north-west shelf region of the Black Sea.



Figure 1: The Danube River through Europe

For some (maybe most) of the countries crossed by the river, it is crucial for local or national economy, as sadly shown by the example of chemical pollution in Feb. 2000 (tons of cyanur from North Romania in Tisza river destroyed about 80% of the river's ecosystem and contaminated Danube).

Several programmes were engaged to protect Danube's ecosystem and reduce the pollution load. This study was supported by the European Commission within a COPERNICUS project. There are other projects aiming at protecting the river and its environment, as the Environmental Programme for Danube River Basin (EPDRB). Within this program, a prototype Danube Information System (DANIS) was developed for some textual information. Furthermore the Danube River Information Network (DBIN) for the management of water quality was initiated by NATO. The development of these and other environmental information and communication activities were in support of the Environmental Programme for the Danube River Basin (EPDRB), Danube River Protection Convention, and Strategic Action Program (Danube Strategic Action Plan 1995).

These projects aim at taking a further important step for implementation of the Danube River Basin Information System on an international scale, to meet the needs of the International

Commission for the Protection of the Danube River and to allow for the participation of the interest groups in environmental protection in the Danube region.

The Bulgarian and Romanian plains constitute the Danube River's watershed, with the Black Sea as outlet (Figure 2). The river is the physical border between the two countries along the south border of Romania.



Figure 2: The Danube River from Budapest to Constanta

1.3. *Recent studies about the Black Sea pollution*

The Black Sea is the biggest inland sea in the world. It is linked in the north to the Sea of Azov and in the south to the Sea of Marmara and the Mediterranean via the Bosphorus, which is both very narrow (1.6 km on average) and shallow (36 m). It is thus a virtually enclosed sea, as deep as 2,000 m in places and with an average depth of 1,240 m. Several of Europe's major rivers flow into the Black Sea, including the Danube, the Don, the Dnieper and the Dniestr. The Black Sea basin includes the greater part of 17 countries, six of which border directly on it. The population of this region is some 160 million. Although its ecosystem is fragile, being vulnerable due to factors such as its shallowness in places, the Black sea had no major problems until the 1970s; on the contrary it enjoyed remarkable biodiversity. Overfishing, man-made pollution, eutrophication and intense shipping traffic are some of the causes of damage to the environment, which has now reached alarming proportions.

The Black Sea has always had an extremely rich ecosystem. The great rivers already mentioned have always discharged nutrients which have been considered a special contribution to the quality of the ecosystem. These nutrients have been the source of substantial production of phytoplankton, the first element of the marine food chain. Precipitating phytoplankton give rise to substantial bacterial activity on the seabed, consuming all available oxygen and leading to the complete disappearance of all life forms below a depth of 180 m. This has always been a feature of the Black Sea which, apart from being the most "anoxic" in the world, has always had a mid-surface area of great richness and diversity.

Unfortunately, for nearly 30 years, the Black Sea environment has been suffering unprecedented damage due to the conjunction of various phenomena. Pollution by large rivers plays an important part in the Black Sea's deterioration. Firstly, owing to over-fertilisation of farmland in their catchment basins, they discharge much too large amounts of nutrients such as nitrogen and phosphorus, causing excessive proliferation of phytoplankton. In moderate amounts, such phytoplankton has been considered beneficial to marine ecosystems, but too much has caused the system to "seize up" and had a devastating, suffocating effect.

A typical example is the Danube which in 1990 alone deposited 40 000 tonnes of phosphorus and 50 000 t of nitrogen into the Black Sea, 10 times more than in 1960. In this respect, the example of the Danube is eloquent. Knowing that the Danube is responsible for 80% of pollution in the Black Sea and that various schemes are under way in the Danube Basin, we

can see that any co-operation concerning the Black Sea and the Danube must be co-ordinated in order to achieve synergy.

In addition, the proceedings of the first Interparliamentary Conference on the Environmental Protection of the Black Sea (Istanbul, 10-12 July 1996), jointly organised by the Parliamentary Assembly of the Council of Europe and the Parliamentary Assembly for Black Sea Economic Co-operation (PABSEC), showed that the pollution generated upstream along the rivers which flow into the Black Sea affect — to some extent, at least — the Mediterranean basin (cf. Sustainable development in the Mediterranean and Black Sea basins, Appendix H1 or <http://www.seafront.org/archive/recoder-report7977.htm>).

Among the various basins of the World Ocean, the environmental degradation in the Black Sea is the most severe. In a recent study by the Intergovernmental Oceanographic Commission (IOC) examining the health of twelve marine areas (Caribbean, North Sea, West African coast, Baltic Sea, Northern FSU, Mediterranean, Red Sea, the Gulf, Asian Seas, Black Sea, Oligotrophic Gyre and the Great Lakes) with respect to various contaminants, the Black Sea received the poorest marks. The most predominant anthropogenic impact is the severe eutrophication experienced in the surface layers. Regarding marine pollution, the Black Sea thus deserves increased vigilance and effective environmental management. The environmental crisis in the Black Sea resulting from anthropogenic forcing, and accompanied by natural variability and climatic changes, is manifested by dramatic changes in its ecosystem and resources. The fishery yields have declined dramatically with 80% reduction in total catch in the last few years, and only six out of the 26 species of commercially valuable fish of the 1960's remaining in exploitable quantities. Heavy metals, pesticides, and hydrocarbons mostly originating from terrestrial inputs (notably from the Danube in alarmingly high amounts: 60 000 t of phosphorus, 340 000 t of inorganic nitrogen, 1 000 t of chromium, 900 t of copper, 60 t of mercury, 4 500 t of lead, 50 000 t of oil) have lead to chemical and microbial pollution, affecting public health and tourism industry (annual losses: 400 M\$, cf. The nato committee on the challenges of modern society, Appendix H2 or <http://www.nato.int/ccms/p00/tor.htm>).

The Black Sea Environmental Series Vol. 10: “The Black Sea Pollution Assessment” gives alarming information on pollution in the sea. It confirms that one of the most significant processes degrading the sea is due to the increased concentration of nitrogen and phosphorus compounds, as a result of agricultural, domestic and industrial sources. The dramatic growth of human population in coastal areas, the “Green Revolution” and the increase of agricultural production through fertilisation and intensive live stock farms since the 1960s, the conversion of forests and wetlands into fields and urban areas and the release of nitrogen oxides in the atmosphere, all contribute to the problem. Eutrophication (a phenomenon caused by over-fertilisation) has developed the problem of low oxygen that in its turn has changed the structure of the Black Sea ecosystem that lead to decrease of biodiversity and reduction in the animal populations. The nitrogen and phosphorus compounds enter the Black Sea from the 17 countries in its drainage basin, mainly through rivers (the three largest rivers are the Danube, Dniepr and Dniestr). The estimations show that about 30 % of the total amount of nutrients originate from the other 11 non-coastal countries and the remaining 70 % - from the six riparian countries. The largest inputs of nutrients originate from Romania; the second from Ukraine, the next in this order are Bulgaria, Russia, Turkey and Georgia (cf. The Black Sea “Eutrophication Syndrome”, Appendix H3 or http://www.bseanetwork.org/Issue2_2.html).

Moreover, the Black Sea is under several stresses: waste from 17 countries drains into the waters of the Black Sea, almost two thirds of the nitrogen and phosphorus in the seawater

comes in from the Danube basin, over 10 million people are connected to sewage systems in the Black Sea Coastal region, and 111 000 tons of oil enters the Black Sea each year from transport of oil through the Danube (cf. Better days for the Black Sea, Appendix H4 or <http://europa.eu.int/comm/research/rtdinfosup/en/sea4.htm>).

To finish with a more optimistic study, if by the early 1990s the Black Sea was in the grip of an extreme environmental crisis due to nitrogen, phosphorus and pesticides, added to agricultural land, and found in the sea at extremely high concentrations, causing massive blooms of micro-organisms, monitoring data show that during the last years the content of biogenous substances in water has stabilised at a certain point which is far below the permissible levels for ammonia nitrogen, nitrates, nitrites and phosphates. This is closely related to a considerably reduced application of mineral fertilisers and pesticides to the arable land, which has brought about a reduction of the biogenous and polluting matters washing out from the catchment basins of the major rivers. The main polluting components of the sea environment are petroleum products (cf. Regional and global ecological problems, Appendix H5).

1.4. Eastern Europe: Economy and situation of Research and Development

As most of its countries transform to market economies, the Europe and Central Asia region's environment has improved. Pollution is declining, and air, water and soil quality is improving. Lead and heavy metal dust levels have decreased in response to lower outputs and new emissions control measures. Particulate and sulfur dioxide emissions from large stationary sources have decreased through industrial decline and price adjustments in the power and metallurgy sectors. Nitrates, heavy metals and toxic chemicals in drinking water have been reduced, and waste water collection and treatment has improved in areas like the Baltic and Black Sea.

But environmental progress has been mixed. In many areas, air quality improvements appear to be less than proportional to the fall of total emissions. Even though particulate emissions from large sources have decreased substantially in some areas, increased emissions from smaller sources like cars, small boilers, households and new commercial establishments have meant that average exposure has remained almost unchanged. Bacteriological contamination risk remains high in drinking water, and may even increase in places with deteriorating water utility operation and maintenance.

Countries in the region with advanced market reforms are more likely than less reformed economies to keep pollution down as they increase their GDP and industrial production. Phasing out subsidies and eliminating market distortions provide a better foundation for efficient natural resource use and sustainable environmental improvements. But even countries successfully transforming to market economies need to complement their reform measures with effective environmental policies and institutional frameworks. Proper environmental management systems need to be developed with clear sets of environmental priorities, established within the financial constraints of the transition process. Since the region's countries are embarking on transition strategies which vary in objectives, speed of transformation, and emerging partnerships, they need access to a variety of instruments and institutional and investment support. The region's most important new challenge is to combine economic growth and recovery with environmentally sustainable improvements.

The regional economic picture is changing rapidly. Some countries in Central and Eastern Europe are facing the immediate challenge of European Union accession; others are undertaking major structural changes and building new trade and economic zones. EU and the World Bank must respond appropriately to each of these differentiated needs. For the accession countries, EU and the World Bank can be instrumental in proposing least-cost strategies for meeting European Union's environmental requirements and financing parts of the public investment programs. For the majority of the countries outside of the immediate EU expansion, EU and the World Bank can mobilize support for economic recovery and environmental management improvements.

In this project, financial support from EU was used to provide up to date measurements devices for environmental questions and acute formation in crop modelling for risk assessment of agricultural practices in the Dabube River's watershed.

1.5. Romania

Romanian plain is surrounded by Danube in the South and by the Southern part of the Carpathian Mountains in the North. Considering counties closed to Danube covers most of the agricultural area of Romania.

The country started a large land privatisation program some years ago. It resulted in an excessive land fragmentation. Statistical data about repartition of cultivated area and major crops exists for each county. In addition the Romanian partners of University of Bucharest conducted a large survey (127 farms managing 88500 ha) to establish a typology of the farms. Major crops and husbandry can be identified for public and private sector. The combination of these data with a typology of different types of farms is essential to obtain an overview of farming systems in Romania. The main productions are maize, wheat, rye and sunflower.

1.6. Bulgaria

Bulgarian plain is surrounded by Danube in the North and by Balkan mountains in the South. The Danube watershed in Bulgaria spreads on 4 640 000 ha. We worked with two climate stations and soil types (Pleven and Ruse) to characterise the Bulgarian Danube plain.

In 1991 Bulgaria broke up old agricultural collectivist structures and started to return lands to private sector. Farms coming from this context are mainly small and agricultural practices often extremely basic. Bulgarian agricultural area was in 1998 distributed between 3 types of exploitations: private associations and co-operatives, public farms managed by State and small individual exploitations. Wheat, barley, maize and sunflower are currently the major crops (55 % of arable lands).

2. Objectives of the study

The final objectives of this work were, on one side, to perform an analysis of risks linked to climate and/or techniques in selected regions of the Danube watershed, in order to deduce recommendations based on simulations with long data sets and different scenarios, and on the other side to develop a complete procedure and the tools to be able to realise the same study at any other place.

It required a typology of agricultural practices in the regions near to the Danube River, to define typical situations. Once soils and crops were chosen, the models calibration could be envisaged, in collaboration with local searchers. It was important to make sure they could complete the same work in other situations without our assistance.

2.1. Definition of studies

2.1.1. Regions and soils

A limitation in the selection of soils was the necessity to locate the experimental sites nearby the research institutes associated to the project. With our three partners (2 in Romania and 1 in Bulgaria), representative soils near to the research institutes were found.

2.1.1.1. Bulgaria

The experimental station of Bojurishte was chosen as geographical site of the wheat field trials in Bulgaria. This site presents an impermeable soil profile that is contrasting to the moderately permeable soil profile of the other experimental site in Chelopechene. Impermeable soils are spread over 399 000 ha that is 8.6% of the area of the Bulgarian part of the Danube River watershed or 17.4% of the agricultural land there (Koynov *et al.*, 1968; Koynov *et al.*, 1980; Penkov *et al.*, 1992; Giurov & Toshev, 1990).

2.1.1.2. Romania

In Romania, the cambic chernozem of Fundulea (near Bucharest) is widespread on about 27% of the surface taken into account in the present study. The reddish-brown forest soil of Bucharest represents about 9% of the arable land considered.

2.1.2. Crops and models

The study aimed at representing as large areas as possible in the regions considered. Therefore main crops were chosen for simulations: maize, wheat, and sugar beet.

2.1.2.1. Maize

Maize is the most widespread crop in Romania. The area cultivated with this crop in the Romanian Danube Plain is about 1 372 000 hectares (49% surface taken into account in this study). 88% of the land covered with this crop is private property. The irrigation is applied especially to the crops belonging to public (state) sector.

Maize is sown over 6-11.2% of the rural territory of Bulgaria. Percentages of area sown with maize are higher for the Danube River watershed: up to 19.2%.

2.1.2.2. Wheat

The area cultivated with wheat in the Romanian Danubian plain is about 676 000 hectares (24% surface taken into account in this study). 66% of the land covered with this crop is private property. The irrigation is applied especially to the crops belonging to public (state) sector.

Wheat is sown over 23-27 % of the rural territory of Bulgaria. It is more specific for the Danube River watershed: up to 34.5%.

2.1.2.3. Sugar beet

Sugar beet is one of the most important technical crops in Romania. The area cropped with sugar beet has decreased every year since 1989, because of modifications in Agricultural property structure and of the settling of market economy, to reach in 1997 1.5% of the total arable surface in the country. In these conditions, the sugar production for 1998 in Romania is estimated to 220 000 tons. The greatest areas cultivated with sugar beet in Romania (39 %) are in the South of the country, including the Danube plain.

2.1.2.4. Rapeseed

In addition, rapeseed as an intermediate crop was eventually introduced. This was an occasion to promote a practice which is recognised as efficient in western Europe but not used neither in Romania nor in Bulgaria.

2.1.2.5. Models

Models for three out of the four crops with very similar structures were available at INRA Grignon, based on the North American model CERES (Jones & Kiniry, 1986). Initial CERES-Maize was modified at INRA Grignon (Gabrielle, 1996) to develop environmental aspects of the model, that was mainly oriented to yield prediction. The same modifications were applied to CERES-Wheat (Ritchie, 86). With the same physical bases, a new model was developed for rapeseed by Vardon (1993) and improved by Gabrielle (1996) and Roche (in prep.). Finally, for the purpose of this project a version for sugar beet was developed (Leviel & Crivineanu, 2000).

2.2. **Simulations of different climates and techniques**

The objective was to use long meteo data sets from representative regions to perform the risk analyses. We could gather for each experimental site 30-year long data series including the minimal required measurements: extreme temperatures (T_{max} and T_{min}), rainfall (P) and global solar radiation (R_g).

The models require initial conditions, especially for soil moisture and temperature. These data were measured for the field experiments, but obviously they were missing for the long weather data series. A common hypothesis consists in starting the simulation at the end of winter, with soil moisture set to field capacity and soil temperature set to an average over a long period. All simulations for risks analysis were computed this way.

Various crop rotations were envisaged, including or not an intermediate crop (rapeseed). At least two crop rotations cycles were computed to eliminate the impact of undetermined initial conditions.

The simulated technical itineraries were adapted from the local agricultural practices. Concerning the irrigation dates, they were adapted in relation to the weather data sets within the simulations, to avoid date-related irrigation that could occur simultaneously with rainfall and provoke accidental drainage/leaching. Concerning fertiliser types, they were chosen in function of local agriculture. In regions with husbandry, organic fertilisers were used in complement or instead of mineral fertilisers.

2.3. Risks analysis and recommendations

Two methods were used to compare the results of simulations, depending on the complexity of the simulation: either for one crop simulated one year with different practices, or for crop rotations over several years.

In the latter case, drainage and nitrate leaching were simply expressed as units per day, due to varying duration of the successive crops. Indeed water and nitrogen availability in the soil or air temperature may change significantly the development of cultivated crops.

With easier simulations (one crop over only one season), environmental impacts were expressed in function of cumulative probability of rainfall. The resulting simulations of drainage and nitrate leaching with increasing probability of rainfall were used to form recommendations according to the local practices, in collaboration with local searchers. The objective is now that these searchers use the results and the methodology to diffuse this information to agricultural and political deciders who could make it applicable at large scale in their respective countries.

2.4. Transfer of technology to local searchers

Great efforts were done to fulfil this aspect of the projects. They consisted in three aspects that are scientific exchanges in research institutes in France and Belgium, specific formations in relation to the project and acquisition of recent material by the eastern partners.

2.4.1. Exchanges

Several periods of exchange allowed eastern partners to have long formations in the different aspects of the project. Short descriptions of these exchanges are listed below.

We insist on the fact that these exchanges represented about 66% of the project duration, that is to say between 550 and 600 days along the 30 months of the project (900 days). It implies a significant time investment mainly supported by INRA Grignon for:

- Modelling techniques.
- Nitrogen balance in wheat field ecosystem.
- CERES- Sugar beet.
- Analysis of the 97' data from sugar beet experiment.
- Maize data analysis and utilisation of CERES-Maize.
- Computing the data for the sugar beet model development and calibration.
- CERES calibration with lysimeter results.
- Experimental measurements and data treatment.
- Risk assessment in Bulgaria.
- Risk assessment in Romania.
- Sugar beet modelling, and risk assessment in Romania.

2.4.2. Formation

2.4.2.1. Crop models functioning

As soon as during the first meeting in Bucharest (December 1997), a detailed presentation of CERES models was proposed to all partners. In addition they were all given a copy of the documentation and could contact directly several authors in Grignon: B. Gabrielle, R. Roche and B. Leviel. See chapter 5 for detailed description of models.

2.4.2.2. Experimental data treatment

To gather the experimental results in a form that could be understood and used easily by everyone inside or outside the project, similar files were used whatever the crop and location. INRA Grignon developed Excel templates to enter rough data.

In addition partners were initiated and incited to the use of macro-commands to avoid repetitive computing tasks. It saved a lot of time and reduced risks of errors.

Finally, templates and macro-commands made easier the conversion of all experimental data of the project in a data base (extract in Figure 3).

COPERNICUS Data											
Sugar Beet											
previous year's residue	Meteo	Soil			Crop						
		Soil Moisture	N analyses	Pest	pheno	crop density	LAI	Fresh Matter	Dry Matter	N content	Leaves
Grignon 1998	Mt		Gr98Nt		pheno	GrSB98de	GrSB98LA	GrSB98FM	GrSB98DM	GrSB98Nc	Leaves
Bucharest 1996	Mt	harvest	cf. harvest		pheno		LAI		BuSB96DM	BuSB96Nc	
1997	Mt	BuSB97SM	NO3 NH4	missing	pheno			BuSB97FM	BuSB97DM	BuSB97Nc	leaves
1998	Mt	BuSB98SM	NO3 NH4	missing	pheno			BuSB98LA	BuSB98FM	BuSB98DM	BuSB98Nc
Chelopezchene or Bojurishte 1997											
1998											
Fundulea 1997											
1998											
Gembloux											

[back to general index](#)

Figure 3: Excel Data Base for sugar beet data

2.4.2.3. CERES Models utilisation

At the beginning of the project, CERES was a search tool not user-friendly. That was a huge loss of time to teach all requirements of the models. So we decided to develop specific tools. An interface (Figure 4) was created by INRA Grignon to manage all tasks linked to CERES utilisation (see chapter 5 for detailed description of modelling tools):

- Input files creation and edition (Visual Basic)
- Meteo files creation (Visual Basic)
- Simulation
- Outputs visualisation (Excel VBA)
- Comparison to experimental data (Excel VBA)
- Documentation of these specific tools

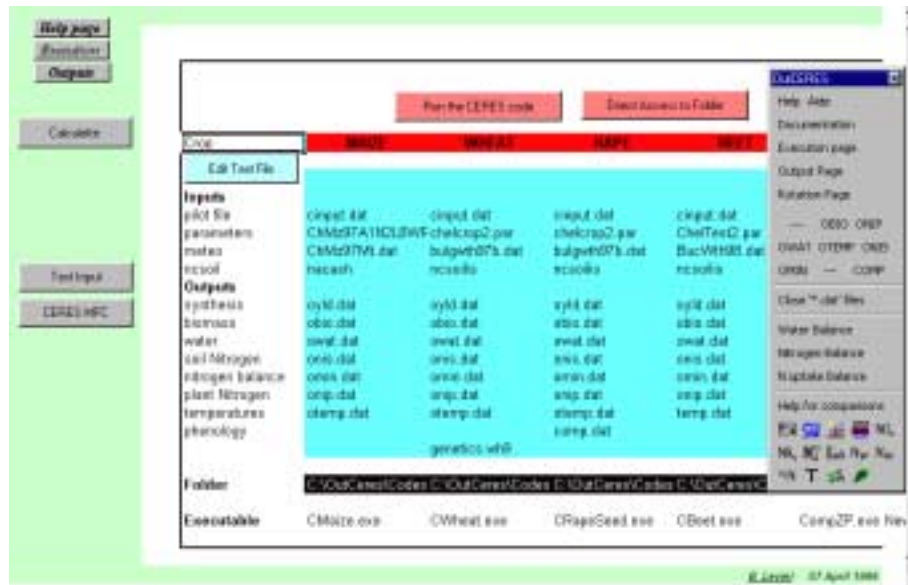

Figure 4: Interface for the use of CERES models

2.4.2.4. Models calibration

Two kinds of situations were encountered:

- Physical parameters were known

Mainly for soil hydraulic properties, a laboratory description was often available, but did not correspond to the CERES model description (different empirical equations). A set of CERES parameters had to be deduced from the laboratory parameters, using Excel solver for instance.

- Development of specific tools

When no similar parameters were available, estimations of error with 1to1 graphs (Figure 5) were used. Such model outputs were obtained with specific macro-commands.

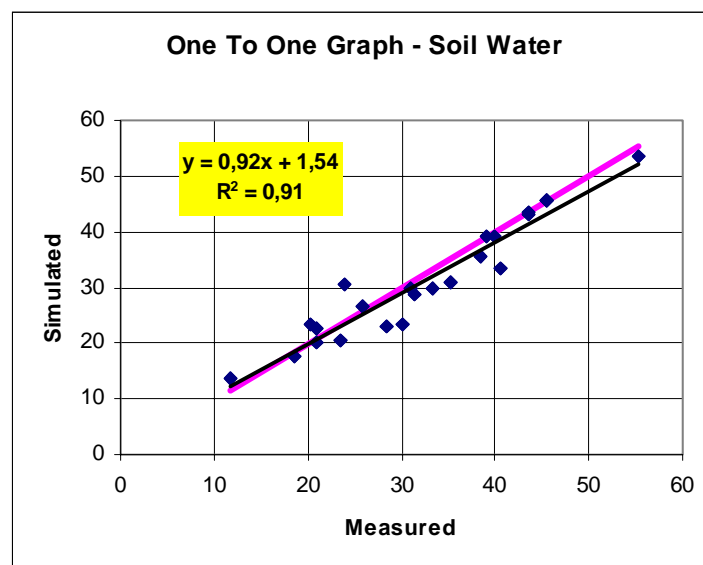

Figure 5: Illustration of a result of a 1to1 graph during calibration

2.4.2.5. Risk assessment

Final objective of the project, a special attention was paid to risk assessment of varying agricultural practices, and mainly to crop rotations. We had to be able to simulate easily every succession of the 3 crops studied, with bare soil or catch crop between them. The interface shown in Figure 6 manages successive simulations and takes the outputs of a simulation as the input conditions of the following simulation. Year by year yields and environmental impacts are stored.

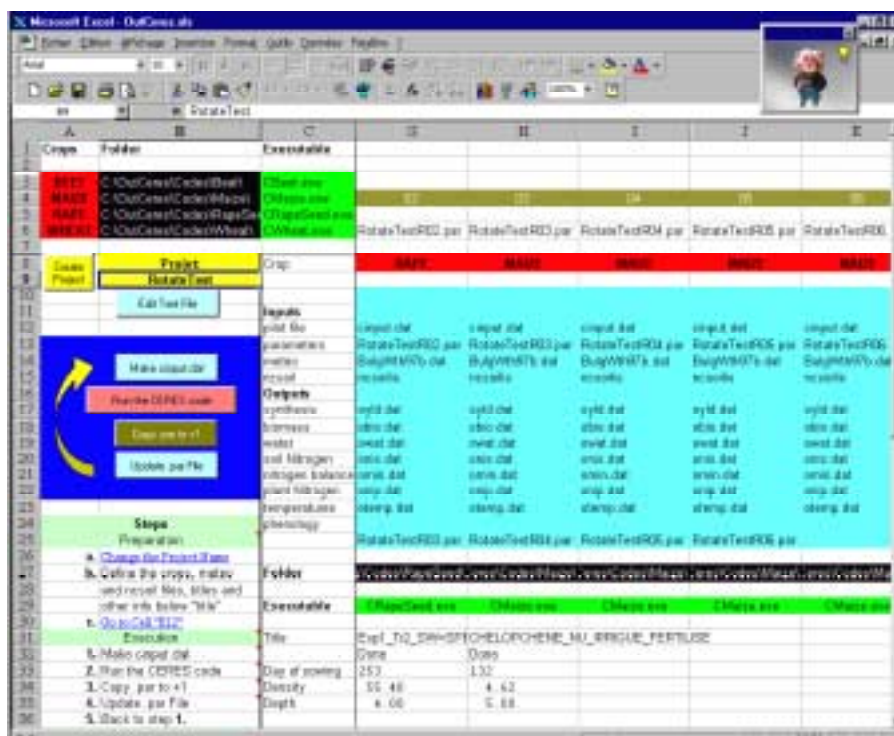

Figure 6: Interface for simulation of crop rotations

2.4.3. Equipment

The project had an experimental part and a modelling part, both of them requiring specific equipment to ensure the same level of quality of the data and the same treatment of information. A part of the budgets were dedicated to update old material or to buy new devices. At the experimental level, Bulgaria needed TDR for permanent and non destructive soil moisture measurements, and Romania bought a High Performance Liquid Chromatograph (HPLC) to perform pesticide measurements. At the modelling level, computer equipments were upgraded in both eastern countries.

3. Design

The thesis was a contribution of a large European project in the Copernicus program. The global project involved five European research institutes from France (INRA - co-ordinator), Belgium (Gembloux), Romania (Fundulea and Bucharest) and Bulgaria (Sofia).

The project described in Figure 7 consisted in three different but not independent steps. First step, field experiments had to be defined and monitored in relation to local and national characteristics. Meanwhile, the models used for simulations had to be improved and adapted to crop rotations (second step). With experimental results of the first year the calibration could be done, before validation with the results of the second season of field experiments. Finally, simulations could be performed and analysed for risk assessment on the basis of the third step's results, the typology of the regions studied.

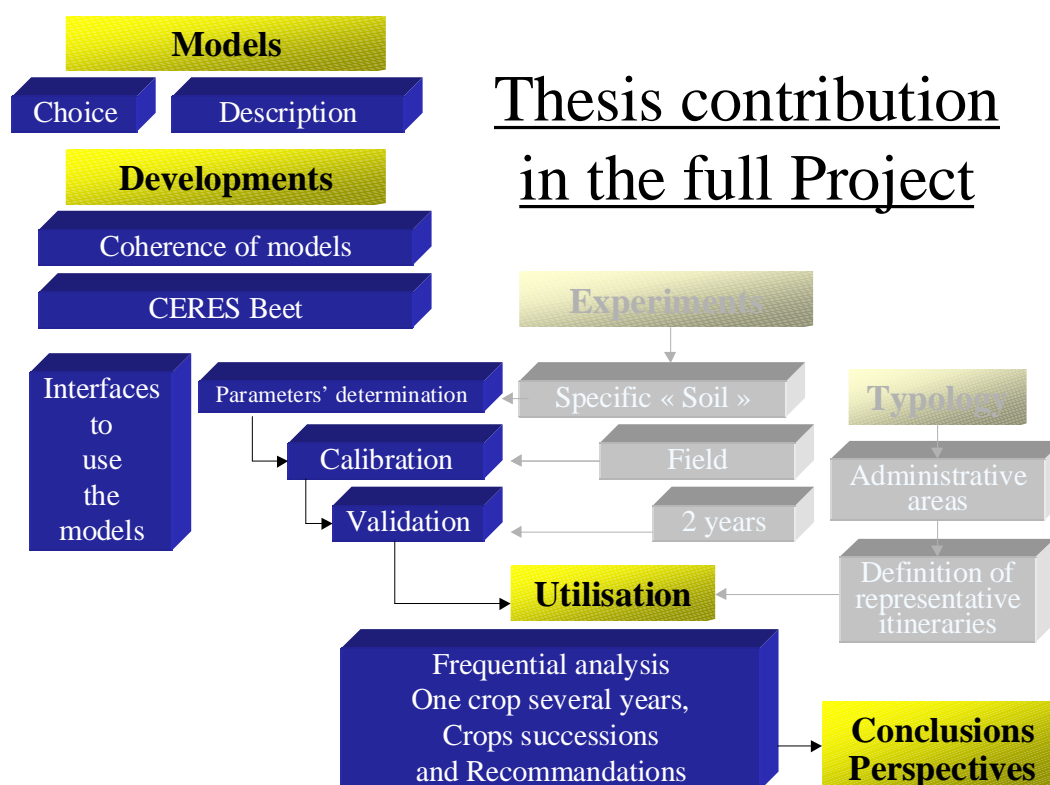

Figure 7: The global Copernicus project. The dark boxes represent the contributions of the thesis in the project. The light boxes are Belgian and eastern countries contributions.

The contribution of the thesis concerned especially the 'models' axis and all 'data treatment' and 'simulations' aspects as illustrated in Figure 7.

3.1. Experimental sites

The locations of the experimental sites had to respond to two imperatives: to be near the research institutes and to be representative of the global situation in the country for soil types and crops.

3.1.1. Choice of crops

We wanted to focus on main arable crops of both countries, in order to have widely applicable recommendations. In addition, several models are available for this kind of crops.

Consequently we considered maize and winter wheat in both countries, and in addition sugar beet in Romania. By now there is no cover crop used in these countries to reduce nitrogen losses by leaching during intercropping. We decided to add scenarios with rapeseed as cover crop to test its effectiveness in different situations.

3.1.2. Typology of regions next to the Danube River

An inventory of agricultural practices along the Danube river on both Romanian and Bulgarian sides was realised in co-operation with local institutes. The goal was to identify few characteristic zones that could be representative of a large proportion of the countries. The criteria were the soil, the climate, and the local agricultural management, especially concerning fertilisation and husbandry (presence of husbandry enhances the use of organic fertilisers -manure- and reduces the use of mineral fertilisers).

3.1.3. Definition of typical situations

As a result of previous steps, typical situations could be defined for field experiments and for modelling scenarios. In each country, two types of soil were selected for field experiments:

- in Romania, a reddish-brown forest soil in Bucharest and a cambic chernozem soil in Fundulea,
- in Bulgaria, a leached cinnamonic forest soil of loamy texture in Chelopechene and a leached chernozem-smolnitsa soil (vertisol) in Bojurishte



Winter wheat field experiments were monitored in Bojurishte (Bulgaria) and Fundulea (Romania). Maize field experiments were monitored in Chelopechene (Bulgaria) and Fundulea (Romania). Sugar beet field experiments were monitored in Bucharest. For all these field experiments, inorganic fertiliser was used.

A few scenarios were proposed to describe typical regions: main crop rotations and fertiliser type, with or without irrigation, and amount of organic fertiliser to incorporate in the soil according to husbandry. We'll present the results of four scenarios with different situations of soil and climate representing the simulations of 22 situations:

- Maize only :
 - two soils \times two climates = 4 situations in Romania
- Wheat-Maize rotation:
 - two soils \times two climates = 4 situations in Romania
 - two soils \times four climates = 8 situations in Bulgaria

- Wheat-Beet-Wheat-Maize rotation:
 - two soils \times two climates = 4 situations in Romania
- Wheat-Rapeseed-Maize rotation:
 - one soil \times two climates = 2 situations in Bulgaria

3.2. Models

3.2.1. Choice of models

Crop simulation is widely (wildly?) used in environment research, and many models are available (Apsim, Century, Ceres, CropSyst, Daisy, LeachM, Nleap, SoilN, Stics, Sucros, Sundial), with different characteristics:

- Mechanistic or empirical
- Complexity of crop module
- Weather data requirements
- Complexity of soil parameterisation
- Time step
- ...

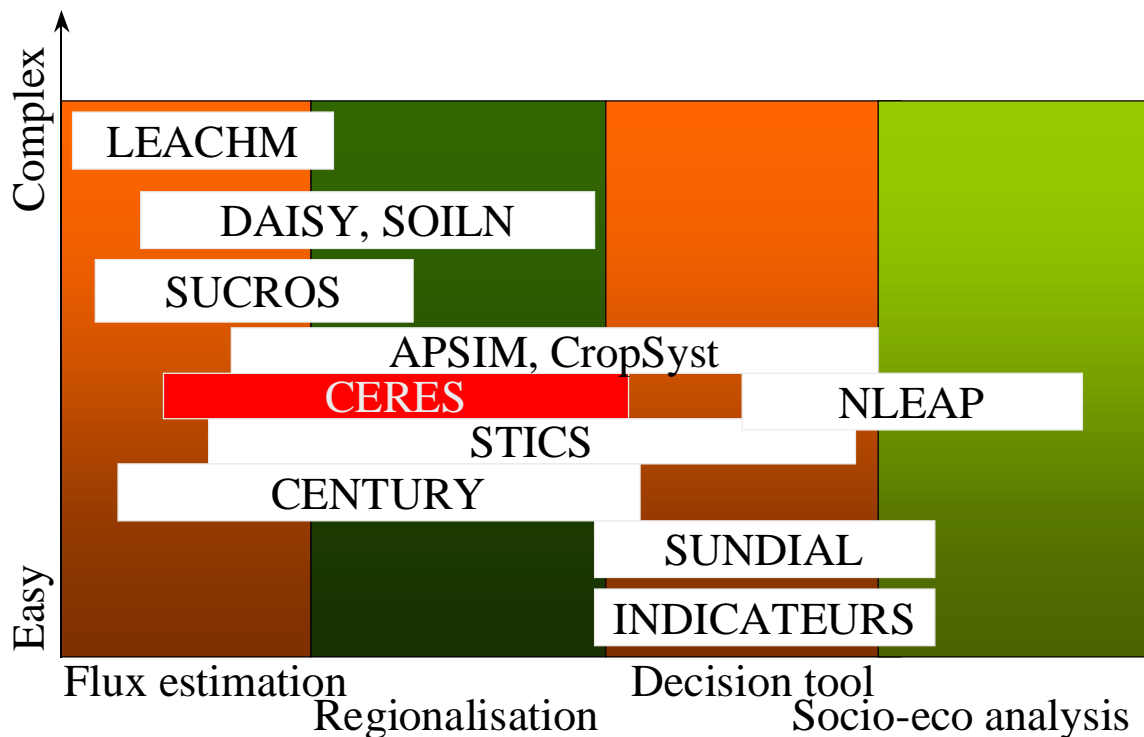

Figure 8 : Overview of existing models (from Gabrielle, personal communication)

Figure 8 illustrates the main existing models in the public scientific community, and it is far from being exhaustive. Vertical axis represents the level of complexity of the processes modelled, horizontal axis lists the fields of application of the different models. Roughly these models can be grouped in three categories.

3.2.1.1. First group of models

LeachM, SoilN (American), Daisy (Danish), Sucros (The Netherlands): at least one aspect of the modelling is very complex, C-N Dynamics or transfers for LeachM, SoilN, Daisy (with a rather poor plant component), or on contrary strong 'plant' components and rather light soil description for Sucros. The time step is generally inferior to the day.

3.2.1.2. Second group of models

Apsim (Australian), Cropsyst and CERES (American) and Stics (French): one module by process, with a search for an equilibrium between the complexity of different processes modelling. The time step is typically the day.

3.2.1.3. Third group of models

Sundial (English), or indicators. They are usually non-dynamic models that use statistics to chain crops, generally used for socio-economic studies or as decision tools.

We wanted a mechanistic model, with a good crop development module available for all crops considered in the project, and few weather data requirements.

CERES (Crop Environment REsource Synthesis) models are daily incrementing simulation models that can simulate the impact of various irrigation management scenarios, nitrogen uptake and nitrate leaching. They have a strong crop simulation component, and the weather input requirements are simple. The models have also been extensively tested with various crops on different soil types and for a range of climatic conditions. At the moment, the bottleneck is a rather complex parameterisation procedure, but projects are in progress to standardise and make easier this crucial step.

3.2.2. Improvement of models

On the basis of CERES models for Rapeseed, Maize and Wheat used at INRA Grignon, and modified by different authors along time, it was decided to make a common structure for all models, with a strictly equivalent soil functioning and similar crop submodels organisation. This task started with modifications of all inputs and outputs organisation (parameters, order, format). Then bare soil simulations were run to eliminate every difference between the codes, at first in soil temperatures, secondly in soil moisture and finally in soil nitrogen contents. The succession of controls corresponds to interactions in the models between temperature, moisture and C-N biotransformations. Indeed, nitrogen contents in soil depend directly on temperature, soil moisture and water transfers, therefore it was not possible to check coherence of biotransformations in the different models as long as soil temperatures and soil moisture were not themselves coherent.

Once this step achieved, we used an updated version of the model to adapt it to sugar beet. The crop module was developed with different data sets obtained with the same cultivar in Romania and in France. At the moment, crops available with these homogeneous bases are:

- Maize
- Wheat
- Rapeseed
- Sugar beet
- Sweet sorghum
- soon: barley

As most research models with many parameters, input and output files and other specific characteristics, this family of models remained really not user-friendly. As the goal of the project was also to make of these models a valuable tool for sustainable agriculture, an effort had to be done to develop clear and easy user interfaces.

Experience of new users allowed to define the main difficulties they encountered. Specific softwares were programmed (and continue to be improved) to help non-specialist users to create and edit input parameter files, meteo files, run the models and visualise outputs.

3.2.3. Models calibration

In CERES, a few parameters control soil water transfers (between soil layers and with the crop), soil biotransformations and heat transfers. The stage of models calibration is therefore among the most important. Yield and environmental impacts predictions directly depend on it. Wrong parameters may, for instance, overestimate drainage and leaching, and consequently create a water stress that would reduce dry matter estimation. A result could be to advise irrigation where it is not necessary. On contrary, drainage and leaching may be underestimated, favouring crop development in the simulations: thus a bad scenario could be recommended.

Two stages of soil calibration are commonly used before validation.

- From preliminary laboratory measurements, physical parameters are initialised. They include figures (hydraulic conductivity at saturation, thermal conductivity, denitrification rate) that are directly entered in the model's parameter file, and curves (retention curve, conductivity curve) used to define parameters sets describing a behaviour with a simplified representation. The retention curve is represented by 2 parameters (Driessen, 1986) and characterised by a wilting point ($pF=4.2$), a saturation ($pF=0$) and a field capacity also called drainage upper limit, for which pF vary with the type of soil. The conductivity curve is represented by 3 parameters (Davidson *et al.*, 1969). Besides, according to the user's background, some terms might be ambiguous, as the field capacity, interpreted differently by agronomic or physic scientists. From our experience, the agronomic meaning roughly corresponds to the saturation for physic scientists.
- Comparison of simulations with this first set of parameters to field experiments data are used to adjust the parameters. Extensive data sets including soil temperatures, soil moisture, soil nitrogen and plant development data are used. Such data sets are the result of time consuming field experiments all along the growth season. 10 such data sets were realised in this project over two years (2 years \times 2 locations for winter wheat, 2 years \times 2 locations for maize and 2 years \times 1 location for sugar beet).
- Validation is performed with the data of the second year of experimentation.

3.3. Simulations

3.3.1. Weather data sets and scenarios

One partner of each participating country collected weather data records of selected zones representing the different kinds of climates encountered along the Danube's basin. The data series had to fulfil the following criteria:

- Daily recording
- Several full years records (30-year series expected)
- Minimum and maximum temperatures
- Rainfall
- Solar radiation
- If available: soil evapotranspiration
- If available: cloudiness

If missing, the last two values are set to -1 in the weather data files, and estimated by the model during the simulation. A specific software developed within the project was used to prepare the data for simulations with CERES.

One partner of each participating country collected information about agricultural practices and characterised few situations representing his side of the Danube's watershed. These typical situations were used to define representative scenarios for both countries (see §8).

3.3.2. Analysis of risks linked to climate and/or techniques

The yearly weather data files of each location were ordered by ascending total rainfall over the year, or over the growing season, to define probabilities of rainfall. In order to limit the number of simulations to run, different comparisons were then performed:

- For simulations of one crop over one season (and eventually the following bare soil period), five or seven weather scenarios were kept, corresponding to 0% (dry), 25% (moderately dry, eventually 2 years kept), 50% (average), 75% (moderately wet, eventually 2 years kept) and 100% (wet). These risk assessments are presented in §6-Calibration and were used to check the models' coherence.
- For rotations, only two weather scenarios were kept, corresponding to 25% (moderately dry year) and 75% (moderately wet year) probability of rainfall. Drainage and nitrate leaching were expressed in units/day in the successive periods of vegetation or bare soil. Results are presented in §8-Utilisation and in appendices.
- Lately, software interface was improved to run automatically models over series of weather data files and extract selected outputs to compare yield and environmental impacts (mainly drainage and nitrate leaching) more precisely. One application is presented in §8-Utilisation.

3.3.3. Recommendations

The recommendations deduced from simulations were expressed as basic rules for local deciders. It's now the objective of our partners in the respective countries to diffuse the results and persuade agricultural authorities that these recommendations should be respected to protect environment. Our aim was also that local searchers continue to use the tools we developed together, in order to process other similar studies, and this way complete the work we only initialised. Finally, a real progress (but still very improbable) would be a bilateral collaboration of these countries, without a so large contribution of western Europe, to protect their environment.

4. CERES-Beet development and bibliography

A lot of literature is dedicated to sugar beet, from all stages of development to modelling. The aim of CERES-Beet was to integrate as far as possible the scientific knowledge described in the existing literature in a model scheme imposed by the CERES' structure. The first step of CERES-Beet programming was therefore the Leaf Area Index modelling, which controls the crop development through the light interception in CERES models. The LAI sub-model was developed on the basis of other CERES models functioning, and with large and high-quality data sets monitored for the project in Bucharest and Grignon. Once the LAI sub-model validated, dry matter production/repartition and root development were calibrated to fit experimental data.

4.1. Bibliography

The stage of bibliography for sugar beet modelling aimed at getting an overview of the scientific knowledge concerning the crop at different steps of its development. This overview distinguished the following steps: sowing, emergence, early growth, leaves development, dry matter accumulation and root development. It raised also two crop-specific aspects: heterogeneousness and base temperature.

4.1.1. Sowing

Sugar beet growers must optimise sowing dates and densities, seedbed preparation and seed placement to ensure successful crop establishment (Durr & Boiffin, 1995).

Sugar yields are closely related to both sowing date and harvest date. Beet crops should be sown as early as possible in spring (Martin & Drewitt, 1984). However, the base temperature for germination is about 4°C; consequently, without genotype selection, low temperatures at the beginning of the cycle may provoke seed formation in the first year (Caneill *et al.*, 1994).

Seedbed preparation and seed placement can have a significant influence on the early growth of sugar beet through seedling size distribution, as well as through emergence rate and duration (Durr *et al.*, 1992). Difficult conditions can induce a lack of plants, delayed emergence, and slow growth after emergence (Durr *et al.*, 1992). Further stages in the study of the early growth of sugar beets would consist in analysing the response of seedling size and emergence delay to environmental factors controlled by tillage and drilling operations (Boiffin *et al.*, 1992).

There is an early absorption of mineral elements. Numerous studies showed the negative effects on germination velocity of high contents in mineral elements near the seeds during germination (Durr, 1994).

Models have been proposed to predict the effects of environmental conditions on sugar beet germination rates (Gummerson 1986; Richard & Guérif 1988). Germination date is calculated from accumulated temperatures since sowing (Gummerson 1986; Richard & Guérif 1988).

4.1.2. Emergence

Sugar beet is especially subject to problems in emergence such as crusting (Fick *et al.*, 1975). In the usual conditions of crop establishment, delays of 10 days or more (100-150 °Cdays) are commonly observed between early and late emergence in the same field (Duval & Boiffin, 1990). When averaged across all years, genotypes, and harvest dates, a delay in emergence of

46 days decreased root yield 38% (from 52.2 to 32.3 t/ha), sugar content 4% (183 to 175 g/kg), and recoverable sucrose 42% (9.25 to 5.34 t/ha) (Lauer, 1997).

Elapsed time to reach the soil surface is calculated from germination date, distribution of aggregates along the way up to the surface, hypocotyl elongation function and soil temperature (Durr *et al.*, 1995). After germination, the path to soil surface is estimated to calculate the hypocotyl's date of arrival to surface. Then, soil surface is evaluated (mainly its moisture) to determine the ability of hypocotyl to get through it (Durr *et al.*, 1995). These authors proposed two tests at this stage:

- If more than 175°Cdays elapsed since sowing, the plant is considered as dead.
- Else, and if there is no crust at surface or a moist crust, plant emerges. If the crust is dry, time elapses until crust is rewet, as long as plant accumulated °Cdays remains inferior to the threshold established for its death.

The factors controlling the time to emergence in field conditions include sowing depth and seedbed structure. The hypocotyl elongation rates indicate that a distance of 2-2.5 cm, corresponding to a usual sowing depth, is covered in 65-75 °Cdays (base 3.5°C) from sowing, assuming no water deficiency and no mechanical obstacles. Emergence time observed under good field conditions are in agreement with such values (Duval & Boiffin, 1990; Durr *et al.*, 1992). The seedling biomass at emergence depends mainly on the initial seed weight, which is consistent with other results on sugar beet (Scott *et al.*, 1974) and other species (Black, 1956; Tamet *et al.*, 1994).

Post-emergence growth is supposed exponential (Durr *et al.*, 1994).

4.1.3. Heterogeneous

A successful crop implies fast and homogeneous early growth (Durr *et al.*, 1992). But underground growth may be disturbed by soil structure and aggregates (Caneill *et al.*, 1994), and since sugar beet seedling size is very heterogeneous even within a given field, it induces a wide range of plant-to-plant variability at the end of the exponential growth period (Boiffin *et al.*, 1992).

The difficulty to obtain stable growth stages datation, and therefore to identify their causes, may be attributed to initial heterogeneousness (Caneill *et al.*, 1994).

4.1.4. Early growth

The crop establishment period includes three different steps: first, germination, which conventionally ends when the radicle protrudes; second, preemergence growth; and third, growth after emergence (Durr & Boiffin, 1995).

Seedling development is generally slow until after four to six foliage leaves have been formed, which may be one month after planting even under favourable conditions (Fick *et al.*, 1975). The pattern of growth is similar whatever the growing conditions. 3 successive phases were identified (Durr & Boiffin, 1995):

- The seedling dry weight and the dry weight of each organ increased (during 4 days after imbibition has started at 20°C)
- The weight of the seed residue did not change any further. The seedling dry weight increased slightly, but there were large changes in the weight of the organs.
- The whole seedling weight began to diminish slowly.

The growth curves were distinct when plotted as a function of aerial thermal time, but not when soil thermal time was the independent variable (Boiffin *et al.*, 1992).

During early growth, individual plants do not compete, leaves and growing points remain close to the soil surface, roots mainly develop in the topsoil which has an heterogeneous structure; water and nutrient requirements remain low, and the young sugar beet are very sensitive to diseases, insects and chemical disorders such as low pH (Boiffin *et al.*, 1992).

From the appearance of the first leaves to the beginning of plant competition for light (around the 10th leaf stage), the sugar beet grows exponentially, with the relative growth rate being strongly dependent on topsoil temperature (Boiffin *et al.*, 1992; Durr & Boiffin, 1995). A single relationship was obtained for each treatment when biomass was plotted against thermal time calculated from the emergence to sampling date (Boiffin *et al.*, 1992).

For Boiffin *et al.* (1992), the aerial individual dry weight at time t is expressed as :

$$W_t = W_0 \exp [k (TT_t - TT_0)]$$

Where k is the slope of the relationship between relative growth rate (RGR) and temperature, W₀ is the aerial biomass at time 0 and TT is thermal time. The basic hypothesis of a constant RGR requires i) a constant rate of dry matter partition between the different organs, and ii) no fluctuation of the environmental factors actually controlling the individual growth rates. In the case of sugar beet at a vegetative stage, the first condition is approximately satisfied as long as the shoot growth is dominant.

The plant biomass at the start of the exponential growth curve (~200 degree-days or 15-20 days on average after emergence) is highly variable (Durr & Boiffin, 1995). Seed size has been shown to influence seedling weight in many species, including sugar beet (Scott *et al.* 1974), but the seedling size also depends on seed placement and seedbed structure (Durr *et al.* 1992).

4.1.5. Base temperature

Accumulated temperatures above a threshold called base temperature is commonly used to describe crop development. There is evidence, from other species, that the base temperature for some developmental processes changes with advancing age of the plant (Milford *et al.*, 1985a). Nevertheless, for each process, several different base temperatures were found in literature for sugar beet.

Phenological stages duration were estimated in °Cdays with a base temperature of 0°C by Caneill *et al.* (1994). The base temperature was set to 0 by Boiffin *et al.* (1992). Thermal time was calculated on the basis of the soil temperature measured on each plot, 2.5 cm below the surface, and with a base temperature of 0°C by Durr *et al.* (1992). A base temperature of 3°C was used by Milford *et al.* (1985a) to calculate the thermal time. Durr & Boiffin (1995) expressed time as thermal time using a base temperature of 3°C. Durr *et al.* (1994) calculated time in sum of temperatures base 3.5°C.

Under controlled conditions, each new leaf required a temperature sum of 31±0.61 °Cdays above 1°C for its appearance compared with 29±0.42 °Cdays in the field (Milford *et al.*, 1985d). The rates of leaf appearance increased linearly with temperature between 7° and 20°C with a temperature coefficient of 0.032 ± 0.0018 leaves day⁻¹ °C⁻¹, T_b=1.0±0.42°C, with

31°Cdays being accumulated between the appearances of successive new leaves (Milford *et al.*, 1985d). A base temperature of 3°C was used for temperature sums associated with rates of leaf expansion and one of 1°C for sums associated with the durations of the leaf expansion phase and with leaf longevity. Martin (1986) plotted LAI against accumulated day-degrees above 3°C.

The number of dead leaves in all crops could be quantitatively described by linear regressions on thermal time above 1°C from sowing (Milford *et al.*, 1985c).

It results from bibliography that base temperature, according to authors and processes, ranges between 0 and 3.5 °C. For our model development, several data sets were compared to optimise base temperature for LAI (see § LAI below). The lowest difference between all series was obtained with a base temperature of 3 °C.

4.1.6. Leaves development

The expansion of the sugar beet leaf canopy tends to be slow in the north of France. Low temperatures during the early spring slow the initial expansion of foliage, so that much of the large inputs of radiation occurring in May and June are wasted. This is an important source of loss of yield (Boiffin *et al.*, 1992).

Sugar beets remove much of the nitrogen from the soil profile early in their growth. They accumulate the nitrogen in leaves and later redistribute it to sustain the growth of other organs, causing the older leaves to senesce. Providing more nitrogen has no effect upon the sizes of the first 6 leaves but increases the final areas of all the later leaves (Milford *et al.*, 1985d).

Leaf size depends on position on the stem and is influenced by sowing date, nitrogen fertiliser rate, plant population and the development of crop water stress (Milford *et al.*, 1985d). Changes in size are mostly associated with changes in the rates, rather than the duration, of expansion. Warmer air temperatures induce faster absolute rates of expansion. On average, leaves require between 300-400 °Cdays to reach full size. In later leaves, it ranges from 320-650°Cdays. The duration of leaf expansion decreases curvilinearly with temperature from c.55 days at 7°C to c.22 days at 20°C (Milford *et al.*, 1985a).

The size of each mature leaf progressively increases from the first up to the 12th-14th leaf and then becomes progressively smaller for each of the succeeding leaves. Final leaf areas at 20°C (c.280 cm²) were four times larger than those at 7°C (c.75 cm²) (Milford *et al.*, 1985c).

In most years the fifth leaf was present for 600°Cdays after reaching full size whereas the 10th was retained for twice as long i.e. for 1200°Cdays (Milford *et al.*, 1985c).

Milford *et al.* (1985c) compared the effects of density. Incrementing the density from 43000 to 66000 and 120000 plants/ha decreased the final areas of the largest leaves from 500 cm² to 400 cm² and 300 cm², respectively, and the positions of these leaves from the 12th to the 11th and 10th.

Milford *et al.* (1985d) also compared the effects of irrigation. The final areas, mean rates and duration of expansion were 380 cm², 14.6 cm²/day and 26 days, respectively, in the irrigated crop and 340 cm², 13.9 cm²/day and 24 days in the unirrigated one. The area of the 15th leaf

was 150 cm² in the unirrigated crop and 300 cm² in the irrigated one and of the 20th leaf, 40 cm² and 150 cm² respectively.

4.1.7. Dry matter accumulation

The yield of sugar beet in the Northern part of its cropping area, is strongly correlated with the amount of solar radiation intercepted during the crop cycle (Durr & Boiffin, 1995). Monteith (1977) showed that total dry matter production of several crops, including sugar beet, is strongly correlated with intercepted radiation. Even with weekly harvests, Milford *et al.* (1980) found considerable variability in the relationship for individual beet crops, but a very good relationship if accumulated yield was plotted against Accumulated Intercepted Radiation. A reduction of leaves development when the leaf area index is lower than 3 leads to a significant decrease of intercepted radiation (Durand *et al.*, 1989).

Martin (1986) used measurements of photosynthetically active radiation above and below the canopy, and leaf area index to determine a radiation extinction coefficient for sugar beet from 4 sowing dates. This coefficient (0.613) was not affected by sowing date. With his data, the efficiency of conversion of intercepted photosynthetically active radiation averaged 2.6 (total dry weight), 1.7 (root dry weight), and 1.3 g/MJ (sugar yield).

4.1.7.1. Radiation use efficiency

The intercepted radiation is transformed into sugar in function of the radiation use efficiency and dry matter partitioning (Caneill *et al.*, 1994). This radiation use efficiency (RUE) applies for new elaborated biomass and includes losses from respiration (Durand *et al.*, 1989).

The conversion of radiation into plant material is reduced by moisture stress, which reduces photosynthesis by causing stomata to close, thus impeding carbon dioxide supply to the leaves (Martin, 1986).

Damay & Le Gouis (1993) used the following relations:

$$DM = RUE * \Sigma PARa$$

$$\Sigma PARa = E_i * PAR_i$$

$$PAR_i = 0.48 * R_g$$

$$E_i = E_{max} * (1 - \exp(-K * LAI))$$

$$E_{max} = 0.95$$

$$K = \text{absorption coefficient} = 0.613 \text{ (Martin, 1986)}$$

Their results indicated that a genotypic variability existed for RUE. The values obtained ranged from 3.07 to 3.76 g.MJ⁻¹ in 1988, from 2.96 to 3.43 g.MJ⁻¹ in 1989, and from 2.97 to 3.43 g.MJ⁻¹ in 1990. It is in agreement with other published data: 3.5 g.MJ⁻¹ by Biscoe & Gallagher (1977), from 3.16 to 4.12 g.MJ⁻¹ by Milford *et al.* (1980) and 2.47 to 2.70 g.MJ⁻¹ by Martin (1986). The values are higher than other published data: Scott *et al.* (1973) found 1.93 g MJ⁻¹, Scott & Jaggard (1978) 1.63 g MJ⁻¹, Milford *et al.* (1980) 1.75 to 2.08 g MJ⁻¹. This value is at the same order of magnitude as that of Gosse *et al.* (1986) and Charles-Edwards *et al.* (1986) for other crops.

Damay & Le Gouis (1993) did not observe variability in the relationship between absorbed radiation and yield of sugar. It may signify that this relation depends more on physical and husbandry factors than on climatic conditions.

4.1.7.2. Partitioning

Photosynthates pass through a pool called reserves and are then partitioned to respiration, growth or storage. In sugar beet, the partitioning priorities for photosynthates are respiration > shoot growth > fibrous root growth > taproot growth including sucrose accumulation (Snyder & Carlson, 1978).

For root sugar yield the conversions efficiencies ranges from 1.2 g/MJ to 1.6 g/MJ (Martin, 1986).

The coefficient of repartition of assimilates between aerial parts et roots is more sensible to drought than efficiency of conversion of intercepted radiation to dry matter (Durand *et al.*, 1989).

4.1.7.3. Nitrogen content

Concerning nitrogen requirements for sugar beet growth, Greenwood *et al.* (1990) proposed two reference curves for C3 and C4 plants which are (with DM expressed in t.ha⁻¹):

$$\begin{aligned} \text{C3 plants: } N_{\text{content}} &= 5.697 \text{ DM}^{-0.5} \\ \text{C4 plants: } N_{\text{content}} &= 4.096 \text{ DM}^{-0.5} \end{aligned}$$

Nevertheless, it seems necessary to define the specific values of the critical N dilution curve coefficients for each species according to the different plant characteristics compartments (Colnenne *et al.*, 1998). This has been done for grassland (Lemaire & Salette, 1984), potatoes (Greenwood *et al.*, 1990), wheat (Justes *et al.*, 1994) and maize (Plenet, 1995). The procedure to define the critical N dilution curve has been proposed by Justes *et al.* (1994). These critical dilution curves could be used to determine the plants' N requirements and to calculate the Nitrogen Nutrition Index which quantifies the nitrogen status of the plants, and can be used in dynamic models to take account of the effect of nitrogen on growth and yield (Colnenne *et al.*, 1998).

Plant N concentration in field crops has been related to the aerial biomass according to the general equation (Justes *et al.*, 1994):

$$Nt = a \text{ DM}^b$$

Where DM is the amount of dry matter accumulated in the shoots expressed in t/ha, and *Nt* is the total N concentration in shoots expressed in %DM. This dilution law can be applied only for plant populations having a regular N uptake (Justes *et al.*, 1994).

4.1.7.4. Stress

Low supply of nitrogen reduces markedly the rate of CO₂ assimilation by sugar beet leaves (Nevins & Loomis, 1970).

Even on nitrogen-deficient plants, old leaves retained large amounts of NO₃-N. Apparently they lacked an effective nitrate reductase system or the nitrate pool was isolated against reduction and export (Nevins & Loomis, 1970).

The rapid recovery of photosynthesis when deficient plants were provided with new supplies of nitrogen (50% within one day) raises an issue for which we do not have an explanation (Nevins & Loomis, 1970).

For Caneill *et al.* (1994) vegetative growth stops either at harvest, or because of climate (water, temperature).

4.1.8. Root development

There is no clear morphological stages for sugar beet (Caneill *et al.*, 1994). Indeed, usual phenological stages are based upon the apparition of new organs. For sugar beet, there is only reiteration of existing structure. Consequently, the description can only be based upon relative growth of different types of organs, 'source' or 'users' of the produced dry matter (Fleury & Caneill, 1984).

Authors distinguished three distinct phases in the vegetative development of the plant; a phase of leaf formation lasting from emergence until the end of July, a phase of root formation or 'tuberization' occurring during August, and a phase of sugar storage or 'ripening' occupying the rest of the season (Milford, 1973). Other authors, on the other hand, whilst accepting that early development was dominated by growth of the foliage and later development by root growth, were unable to distinguish separate phases of growth and sugar storage in the root (Milford, 1973). There is a progressive shift in partitioning to the storage root as the crop develops. No sudden transition occurs (Milford *et al.*, 1988).

There may be a mechanism operating within the root that maintains an almost constant distribution of sugar between growth and storage over a wide range of photosynthate supply. However, the control must be modified by such factors as genotype, soil conditions, additional nitrogen and plant density, all of which are known to alter the sugar percentage in root dry matter (Milford, 1973).

There is considerable variation between crops in the proportion of total dry matter allocated to the storage root and sugar early in the season, from 25% to 40% for dry matter, and sugar ranges from 13% to 38%. Later in growth, virtually all of the total dry matter is allocated to the root and about 75% of it to sugar in some crops, but only about 70% to the root and 50% to sugar in others (Milford *et al.*, 1988).

The description of early growth as an exponential function of thermal time ceases to be acceptable around the 10-leaf stage since there is mutual shading of neighbouring plants, and preferential allocation to the root begins (Boiffin *et al.*, 1992).

In natural environments many factors such as the supply of nutrients may directly or indirectly regulate growth through their effects on photosynthesis. The usual symptoms of nitrogen deficiency (yellow, small leaves) are foliar characteristics which indicate at least that the gross photosynthetic apparatus has undergone modification (Nevins & Loomis, 1970). Increasing competition from the developing storage root for assimilated carbon could slow the leaf appearance rate (Milford *et al.*, 1985b).

Although the rate of photosynthesis was reduced as much as 40% when plants were grown for 14 days without nitrogen, the effects were reversible, and activity could be restored to the normal rate within 4 days by adding nitrate nitrogen to the deficient nitrogen solution (Nevins & Loomis, 1970).

As the concentration of sugar is lowest in early harvests of late sown beet crops, it may be better if these crops are harvested later (Martin & Drewitt, 1984). In addition, the results of Loomis & Nevins (1963) indicate that field-grown sugar beet plants should be permitted to

become nitrogen deficient at least 6 weeks prior to harvest. If harvest is made during cool, autumn weather after a period of nitrogen deficiency and, perhaps, moisture stress, these conditions favour a greater sucrose concentration and a lower concentration of soluble non-sucrose materials. It is common to speak of this as a 'maturation' or 'ripening' period (Fick *et al.*, 1975).

Highest total sugar yields were around 17 t/ha (Martin & Drewitt, 1984). Data presented by Martin (1983) indicates that the fresh weight of the crowns is equal to about 12% of root fresh weights of sugar beet.

4.2. LAI

Nomenclature

A_i	Appearance of leaf i /GDD
d	Plant density /plant m^2
dS_i	Leaf i area increase / cm^2 GDD $^{-1}$
DAS	Days after sowing (DAS 1 = 29 April 1997)
f	Leaf-appearance rate /GDD
Gd_i	Leaf i growth duration /GDD
GDD	Growing Degree Days after emergence / $^{\circ}C d^1$
GDD $_x$	GDD with a temperature base of x $^{\circ}C$
i	Leaf number
K	Kvêt coefficient (leaf length/leaf width)
LAI	Leaf Area Index / $m^2 m^{-2}$
L	Leaf length /cm
l	Leaf width /cm
Ll_i	Leaf i life duration /GDD
$N_{xxx,irr}$	Treatment with xxx kg N/ha, irrigated
$N_{xxx,dry}$	Treatment with xxx kg N/ha, non irrigated
S_i	Leaf i surface / cm^2
$S_{i,max}$	Leaf i maximum surface / cm^2
T_b	Temperature base / $^{\circ}C$

4.2.1. Materials and methods

4.2.1.1. Field location and soil characteristics

Experiments were carried out in 1997, at the University of Agronomic Sciences of Bucharest, in the Didactic Field for Land Production (44°30' N, 26°13' E, 95 m altitude) on a reddish-brown forest soil whose main characteristics are a silt-clay texture (38 % clay), and a pH of 6.8; the wilting point and the field capacity were estimated to 13 % and 25 %, respectively.

In this region, the climate is continental. Figure 9 shows the main climatic data for the experimental period, compared to the average over 25 years. The average temperatures are -1.2°C in winter, 10.4°C in spring and autumn and 21.3°C in summer. The average rainfall is 550 mm in the year with a maximum of 78 mm/month in May and June.

It can be observed that 1997 climate was colder and more rainy than the 25-year average. In April, the weather was particularly unfavourable to the sowing of sugar beets. The average temperature was very low (5°C) and the rainfall was abundant (190 mm); this constituted unusual bad conditions for sowing with temperature 5°C lower than the 25-year mean and 4 to 5 times more rainfall than the 25-year mean. Consequently sowing was postponed to the end of the month. In addition temperatures remained low at the end of the vegetative period, and the rainfall surpassed the average by 400 mm. However differences between dry and irrigated treatments could be observed due to a relatively dry period at the beginning of the experiment.

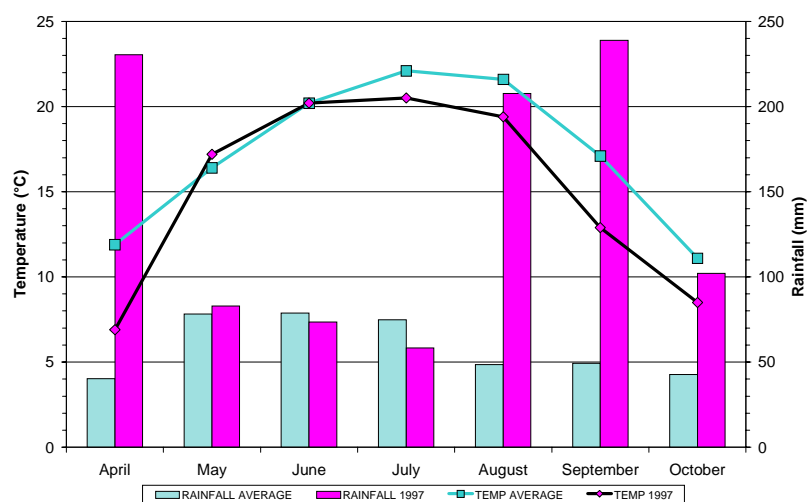

Figure 9: Temperature and rainfall of the experimental season in Bucharest compared to 25-year average.

4.2.1.2. Treatments and replicates

Sowing was made on 29 April 1997. The genotype used was Emma. Each plot consisted in 14 rows, 6 m long, 50 cm apart, in 5 replicates, representing an area of 42 m². The experiment included three nitrogen treatments (0, 150 and 300 kg N/ha) with and without irrigation in order to obtain data sets in limiting and non-limiting conditions. They are referred as N0irr, N0dry, N150irr, etc, for 0-nitrogen irrigated, 0-nitrogen non-irrigated, 150-nitrogen irrigated, etc. Before ploughing in November, 100 kg P₂O₅ ha⁻¹ and 100 kg K₂O ha⁻¹ were applied. The herbicide treatment was made with 1.5 kg lenacil /ha, before sowing.

4.2.1.3. Leaves appearance and senescence

In every plot 3 plants were individualised which were used for determination without destruction of the leaf-appearance rate, the number and the dimensions of the leaves and the senescence.

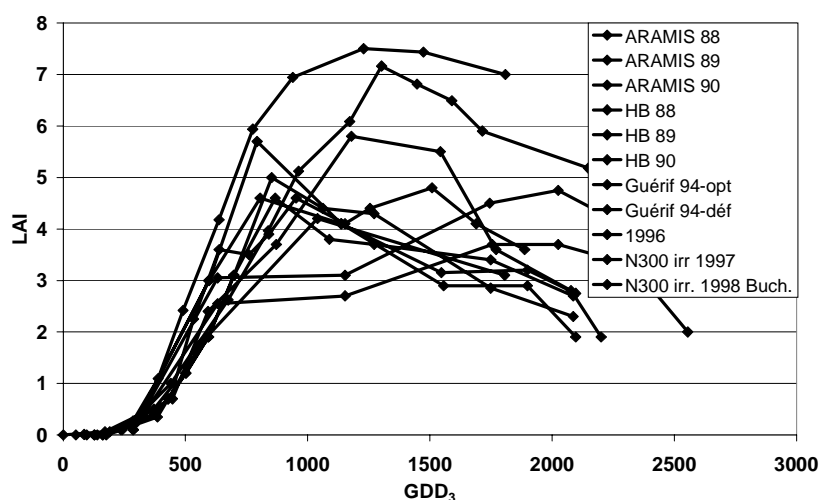

Figure 10: Optimisation of Temperature base with LAI data sets from literature.

Leaves appearance was observed every 2 or 3 days by counting the new leaves that had appeared. Firstly every week, then every other week, the dimensions of the leaves were

measured: length and maximum width of the leaf blades whose length was over 5 mm. Senescent leaves (more than 75 % of the leaf blade yellow) were noted and measured, but they were removed from the *LAI* calculation.

Different temperature bases are commonly found in literature, such as 0 °C (Boiffin *et al.*, 1992; Caneill *et al.*, 1994; Durr *et al.*, 1992), 1 °C (Milford *et al.*, 1985a) or 3 °C (Martin, 1986; Durr & Boiffin, 1995). Martin (1986) related that leaf expansion rate responded linearly to temperature above 3 °C, but was zero below this base temperature. However, because the temperatures on the studied site always exceeded 9 °C between emergence and harvest in 1997, which is common in that region, the choice of the temperature base below that threshold only modifies the slopes of the relationships plotted against Growing Degree Days after emergence (*GDD*) and is not significant for the accuracy of the model. As this model shall be used with various climates, several *LAI* data sets from literature of sugar beets grown in potential conditions (Damay & Le Gouis, 1993; Guérif *et al.*, 1995; Leviel & Crivineanu, 2000a) were used to determine an optimal temperature base (Figure 10). The lowest difference between all series was obtained with $Tb=3$ °C.

4.2.1.4. Leaves measurements and *LAI*

Leaf area was estimated every 10-12 days, with the following relation:

$$S = K (L * l)$$

Where *S* is the leaf blade surface in cm², *L* its length in cm, *l* its maximum width in cm and *K* a coefficient depending on the crop.

This estimation was checked and *K* was determined with two standard methods: planimetry and weighing. For the first method, the optic planimeter (LI-3100 Area Meter) calculates the area of each leaf among a sampling of 20 leaves. For the second one, the leaf blade boundaries of these 20 leaves were drawn on paper (80 g m⁻²), then cut up. The reproductions in paper were weighted, and their weights expressed in g were divided by 0.0080 to deduce the area of each leaf in cm². The accuracy of both methods is verified, as shown on Figure 11, with a regression coefficient of 0.99 and a slope of 1.00. With the linear regressions between the areas and the products *L***l*, we obtained *K*=0.77 (Figure 11). This is in agreement with Kvêt (1966) and Milford *et al.* (1985a) who proposed values of 0.76 and 0.75, respectively, for sugar beet.

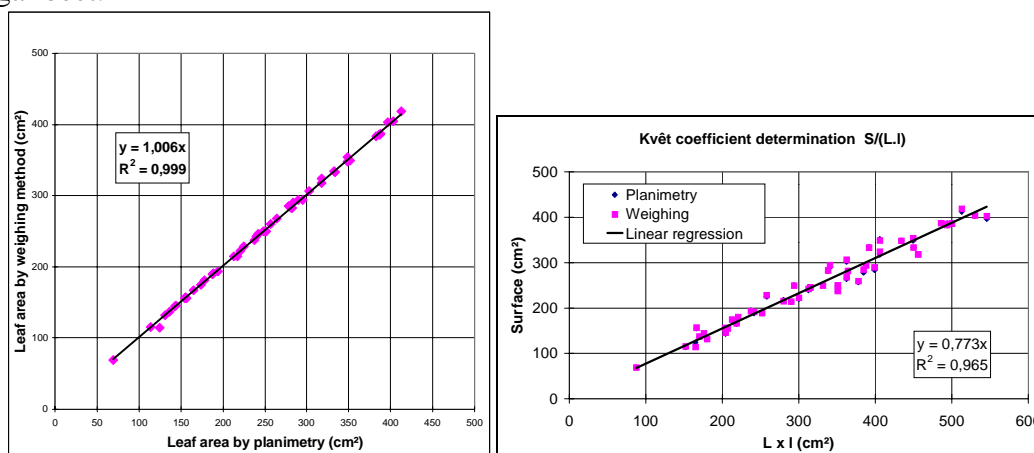
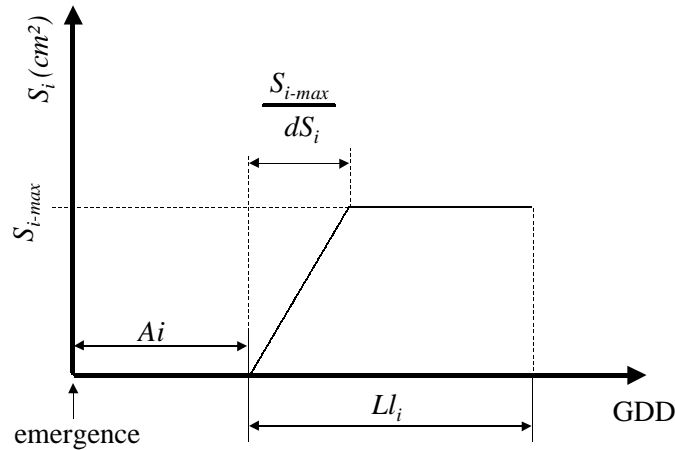

Figure 11: Validation of the leaf area measurement method.

Figure 12: Area dynamics of leaf i .

4.2.1.5. LAI model

The model considers the development of each leaf individually. After emergence, a constant leaf-appearance rate (f) establishes the beginning of growth of each new leaf (A_i where i is the leaf number). Once appeared, the leaf area (S_i) increases until it reaches its maximum (S_{i-max}) at a growth rate (dS_i) that depends on the leaf number. Then the area remains unchanged till senescence defined by the leaf life duration (Ll_i). Figure 12 illustrates leaf i area development. The areas of every living leaves are added to estimate the total leaf area of a plant, and multiplied by the plant density (d) to determine the LAI as follows:

$$LAI = d \cdot \sum_i S_i \quad \text{Eq. 1}$$

4.2.1.6. Stress

Stress conditions may induce modifications of d , Gd_i , S_{i-max} and Ll_i and deeply modify the dynamics of LAI . In the LAI model, at every time step, the model parameters can be modified in relation to water and nitrogen status of the soil. Because of these changes, each leaf may have its life duration (Ll_i) or maximum area (S_{i-max}) modified, with different effects according to the situation of every leaf at the moment when the change occurs.

Effects of water and nitrogen stress are presented and discussed later in this chapter. The modifications of the model parameters have to be related to water and nitrogen status of the soil before including this LAI model in a CERES-like structure. The required soil measurements were performed in Bucharest in 1997, as well as in 1998 during a second campaign of measurements to develop this crucial part of the model (Leviel & Crivineanu, 2000c).

Increase of life duration (Ll_i)

If the stress occurs when the leaf area has already reached its maximum, the leaf keeps its size but lives longer (Figure 22-a1). But obviously if it occurs when the leaf has already died, nothing happens (Figure 22-a2). On contrary, if Ll_i decreases when the leaf is already older than its new life duration, it immediately dies (Figure 22-a2 interrupted line).

Modification of the maximum area (S_{i-max})

If the maximum area of a leaf decreases when the leaf begins to grow, the leaf follows thereafter the new area dynamics (Figure 22-b1). But if this occurs when the leaf has already

exceeded the new maximum, the leaf remains at its size and lives until its new end of life (Figure 22-b2). If the maximum area of a leaf increases when the leaf is growing, the leaf follows thereafter the new area dynamics (Figure 22-c1). But if the leaf area has already reached its maximum, the leaf keeps its size but lives until its new end of life (Figure 22-c2).

4.2.1.7. Data for validation

Within the same European project, a similar experiment was monitored in Grignon (France, 48.9°N, 1.95°E, 125 m altitude), with and without irrigation and with two levels of fertilisation. The soil in Grignon is a silty clay loam. The same cultivar was used, as well as the same depth and density of sowing, on the 1st April 1998. Figure 13 shows the main climatic data for the experimental period, compared to the average over 12 years.

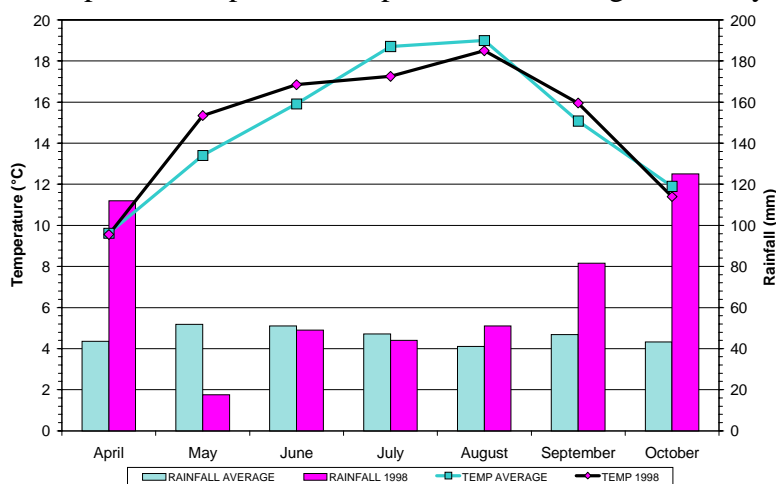

Figure 13: Temperature and rainfall of the experimental season in Grignon compared to 12-year average.

Our experience of previous similar measurements allowed us to monitor only one leaf out of two until leaf 10, then one out of five. Dimensions of intermediate leaves are extrapolated. This diminished significantly the amount of time spent in the field without a loss of accuracy, as confirmed by Figure 14.

4.2.2. Results

4.2.2.1. Leaf-appearance rate

Boiffin *et al.* (1992) related that in the usual conditions of crop establishment, delays of 10 days or more ($100-150 GDD_0$) are commonly observed between early and late emergence in the same field. The emergence date was set as the appearance of half of the beets.

Figure 15 shows the means of the replicates of leaf-appearance for the six treatments. Student *t-test* demonstrates that no significant difference was observed between any couple of treatments, whatever the nitrogen fertilisation or the irrigation. Linear regression is consistent with the observations, with correlation coefficients between 0.992 and 0.997. The mean slope of the regression is then $f^{-1}=0.0255$ leaves/ GDD_3 that is to say:

$$f = 38.9 \pm 2.5 GDD_3 \text{ leaf}^{-1} \quad \text{Eq. 2}$$

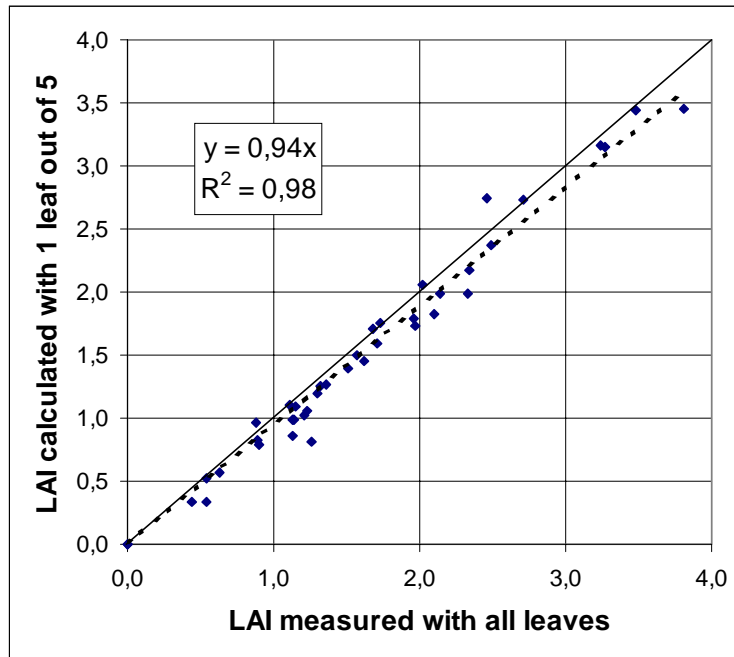

Figure 14: Comparison of the *LAI* calculated with the measurements of all leaves to the *LAI* calculated from the measurements of 1 leaf out of 5. Each point represent one of the 36 monitored plants on the 27th July 1998.

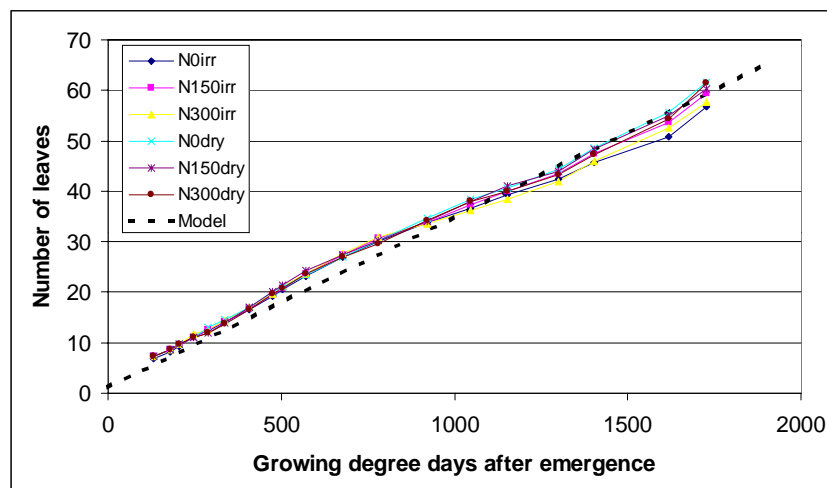

Figure 15: Leaf-appearance rate of all treatments as a function of growing degree days ($T_b=3\text{ }^{\circ}\text{C}$).

In this experiment, sugar beet had new leaves until harvesting in October. It represented up to 67 leaves and the mean observed was 60 leaves/plant. The last leaves areas remained nevertheless very small.

4.2.2.2. Leaves maximum areas

Conversely to leaf-appearance rates, the leaves maximum areas were significantly different according to the treatments. After a joint increase until leaf 7, it remained unchanged for a time that depends on both fertilisation and irrigation (Figure 16).

In potential conditions, the plateau lasts until leaf 31 then the maximum area decreases to the much lower value that is observed about from leaf 60 on (Figure 17). However, it must be noticed that when harvest occurs some of the youngest leaves may not have finished to grow. Therefore measurements underestimate the maximum leaf area of the last leaves. For this

reason, the model was set to overestimate the maximum leaf area of the late leaves that do not tend to zero.

4.2.2.3. Leaves growth

Once the leaf has appeared, its area is supposed to grow with GDD as follows until it reaches its maximum area S_{i-max} :

$$S_i = dS_i \cdot (GDD - A_i) \quad \text{Eq. 3}$$

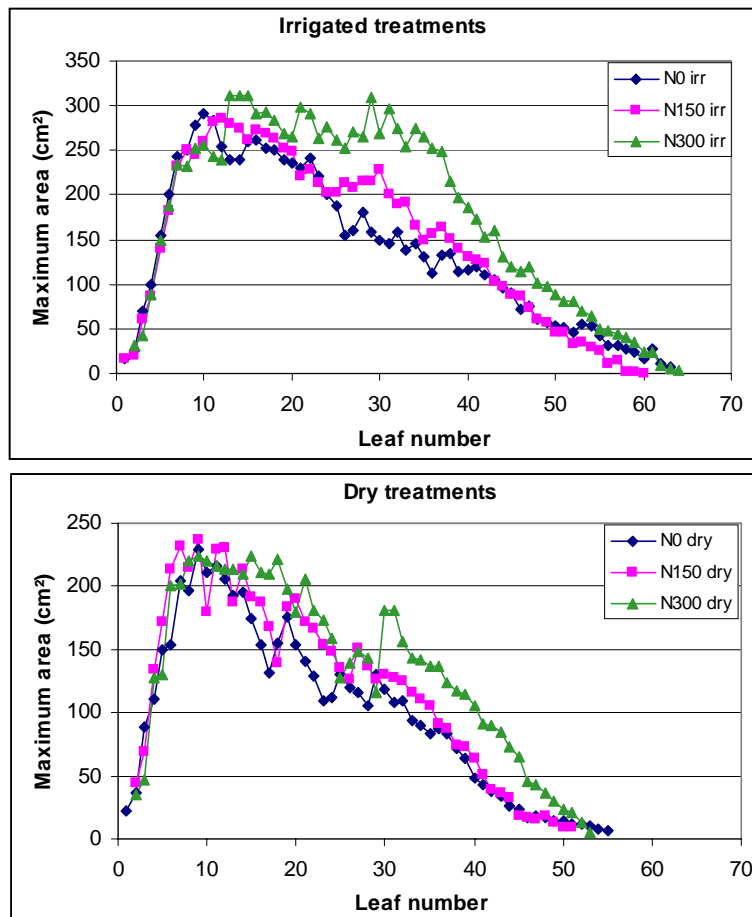

Figure 16: Leaves maximum areas observed for the six treatments. *irr* stands for irrigated and *dry* for non irrigated.

The growth duration is $Gd_i = S_{i-max} / dS_i$, see Figure 12. With the experimental data we estimated roughly the leaves growth duration from the dates of appearance and the dates when the leaves ceased to grow (Figure 18). Like in maximum leaf area calculation, the development of the sugar beet canopy until harvest arose problems in the calculation of leaves growth duration and leaves life duration. The results for the latest leaves might not be valid. As Milford *et al.* (1985c) we observed a tendency of increase of growth duration in later leaves.

4.2.2.4. Leaves senescence

The estimation of Ll_i was deduced from the dates of appearance and the date when the leaf was considered senescent. The first leaves lived less than the ones after the tenth, with a linear increase of life duration in this interval. Thereafter Ll_i remained steady around this value.

The leaf is therefore considered senescent when $GDD = A_i + Ll_i$ (see Figure 12).

It is important to know that once senescent, the leaf might remain on the sugar beet several weeks. However, because of its position at the bottom of the collar, it does not induce shading on the canopy.

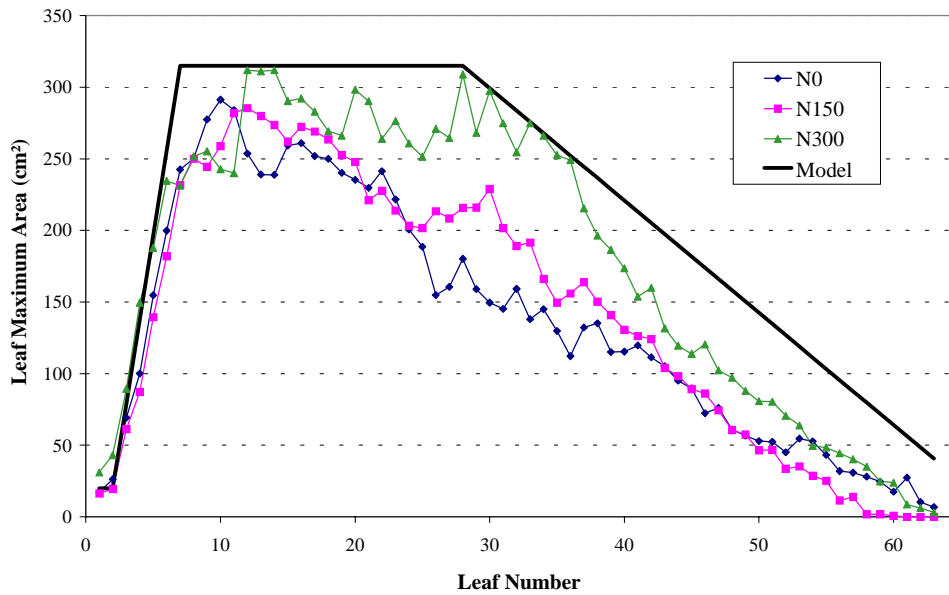

Figure 17: Measurements of leaves maximum areas in potential conditions and illustration of the model deduced.

4.2.2.5. Model results

Calculations were performed to draw LAI dynamics and to compare it to the observed data (Figure 20). Parameters were determined by fitting the experimental data described above, then optimised with the Microsoft Excel[®] solver by minimising the RMSE. The different sets of parameters can be used to associate water and nitrogen status of the soil to changes of the parameters in a complete crop model (Leviel & Crivineanu, 2000b).

For a given value of GDD , S_i is calculated as follows:

$$\left. \begin{array}{l}
 \text{if } GDD < A_i \\
 \quad S_i = 0 \\
 \text{if } A_i < GDD < A_i + Gd \\
 \quad S_i = dS_i \cdot (GDD - A_i) \\
 \text{if } A_i + Gd < GDD < A_i + Ll_i \\
 \quad S_i = S_{i-max} \\
 \text{if } A_i + Ll_i < GDD \\
 \quad S_i = 0
 \end{array} \right\} \text{Eq. 4}$$

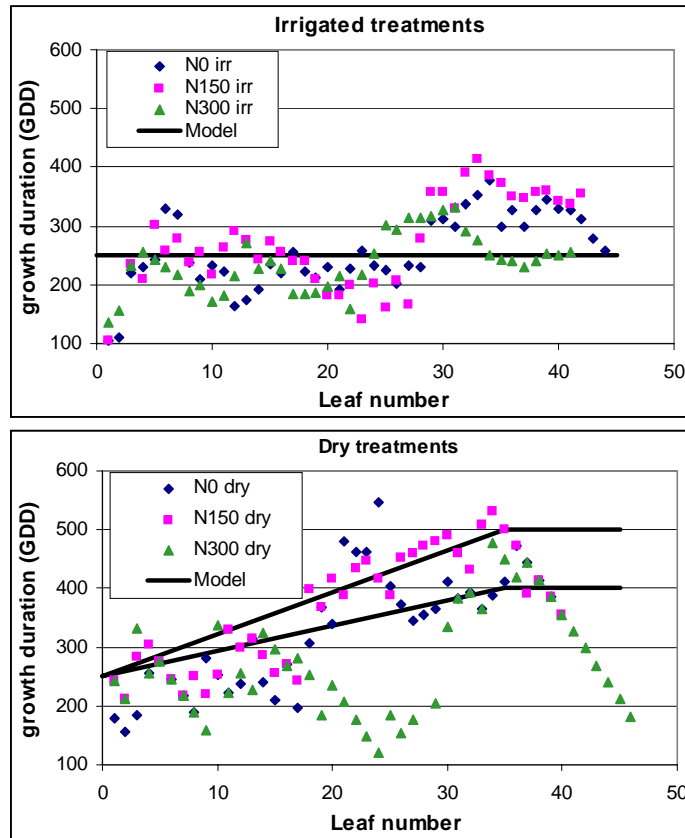

Figure 18: Measurements and estimation of the leaf growth duration .

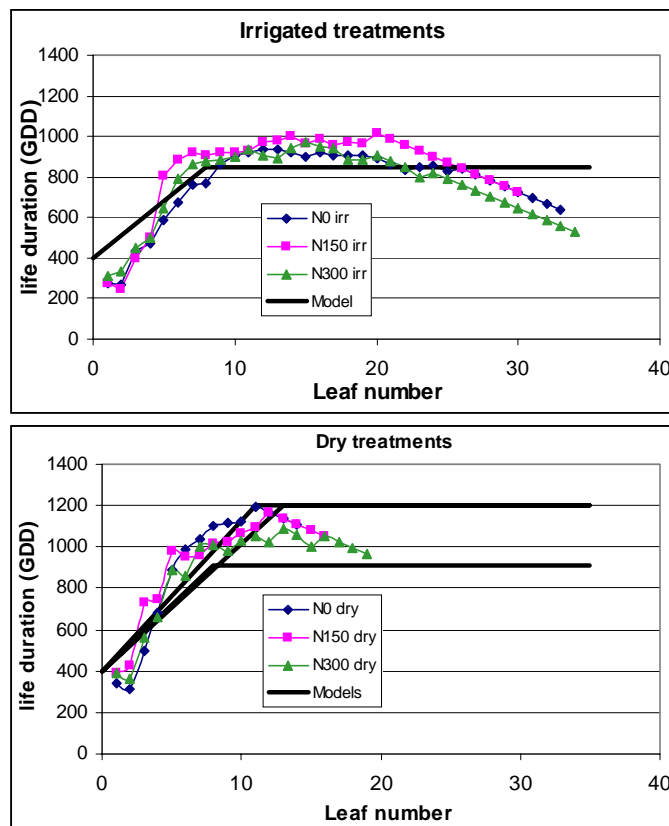

Figure 19: Measurements of leaves life duration and illustration of the model deduced.

The *LAI* is then calculated with Eq. 1. Although the variability between replicates was strong, the results averaged for each treatment are very good, as show Figure 20 and Table 1, where the parameters are gathered. The two first series of scenarios (without increasing growth duration) show that the model has a very good accuracy with 5 parameters only. In that situation, error on growth duration is compensated for by leaf life duration and bigger late leaves. A more mechanistic approach requires to take into consideration the observed increasing growth duration, like in the last scenario. This required the addition of two parameters and the corrections of the ones cited above (*Gd*, *Ll*, *S_{i-max}*). This improvement of the model does not improve significantly the simulation.

4.2.3. Discussion

4.2.3.1. Canopy development

Phyllochrone

New leaves develop from the single apical meristem at the centre of the rosette at a more or less constant rate characteristic of the variety, from two to four or five leaves per week (Fick *et al.*, 1975). We observed an average of about 2.8 leaves per week, but we preferred to refer to growing degree days, which gave a constant phyllochrone along the season (Figure 15), as for Milford *et al.* (1985a).

In addition, like us, Fick *et al.* (1975) observed also a relatively stable leaf number per plant.

Shading

The early sugar beet growth is commonly described as an exponential function of thermal time until the beginning of plant competition for light, around the 10-leaf stage (Boiffin *et al.*, 1992; Durr & Boiffin, 1995). The model and our results are consistent with that observation, and it simulates a fast early growth until leaf 7, where the maximum leaf area reaches its maximum. Physiologically, it corresponds to the moment when preferential allocation to the root begins (Boiffin *et al.*, 1992).

Growth

There is no real morphological stage for sugar beets, because the existing structure is repeated and no new organ appears, at least during the experimental period (Fleury & Caneill, 1984; Caneill *et al.*, 1994).

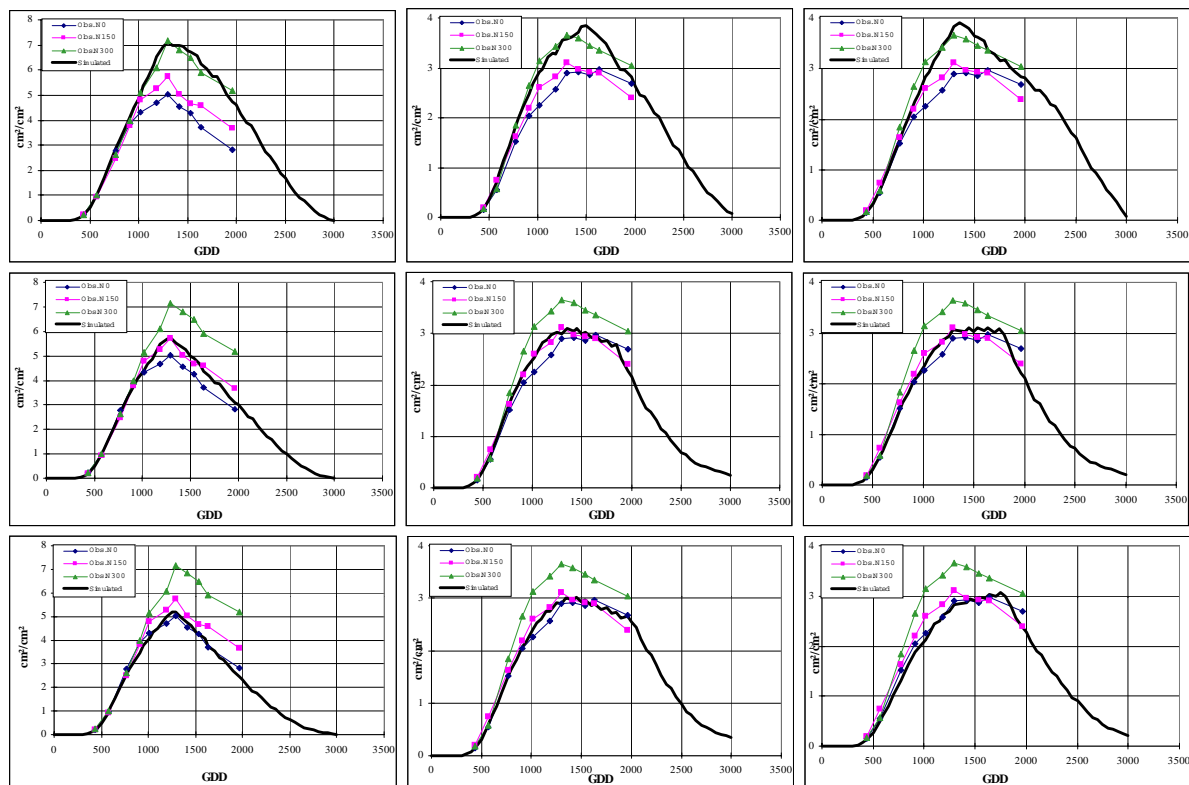

Figure 20: Measured LAI dynamics of the Bucharest experiment compared to the model results. Each row corresponds to a level of fertilisation (300, 150 and 0N), the first column is with irrigation, the others are without irrigation and with 5 and 7 parameters, resp.

According to Fick *et al.* (1975) the first 20 leaves constitute a juvenile group with size of blade and length of petiole increasing with successive leaves. Leaves 15 to 20 are usually the largest in area, and subsequent leaves are somewhat smaller and relatively constant in size and shape. However Fick *et al.* (1975) and Milford *et al.* (1985d) also precise that the length and area of leaves are strongly influenced by variety, number of leaves on the plant, mechanical condition of the seed bed, osmotic potential of the soil solution, incidence of pests and diseases, climate, and nutrient supply. Besides, Milford *et al.* (1985c) observed that incrementing the density decreased the positions of the largest. Our results are consistent with these observations, the dimensions of our petioles increased until leaf 7-11 only, which were usually the largest in area. The development of the following leaves depended upon the field conditions and varied deeply with water and nitrogen supply.

Concerning the duration of growth, with optimum conditions, a leaf could grow rapidly for 21 days, and would cease growth in 28.5 days (Fick *et al.*, 1975). With temperatures between 15 and 20°C, it represents from 250 to 500 GDD_3 , which correctly matches our measurements (Figure 18). Milford *et al.* (1985a) observed 220 to 375 GDD_3 in controlled conditions.

Senescence

It is commonly assumed that the rate of shoot senescence is linear with respect to shoot mass, although no work was found which related senescence to shoot mass (Webb *et al.*, 1997). We preferred to simulate senescence and biomass independently, so we only expressed senescence as GDD after appearance. Like Fick *et al.* (1975) we observed that new leaves appear more rapidly than old leaves die. The variability between replicates and treatments was very strong. However the results averaged for each treatment (9 plants/treatment) resulted in a

Scenarii Synthesis	Irrigation			Fertilisation			Increasing growth duration		
	N300 Irrigated	N150 Irrigated	N0 Irrigated	N300 Dry	N150 Dry	N0 Dry	N300 Dry	N150 Dry	N0 Dry
App	37	37	37	37	37	37	37	37	37
MaxGr	450	450	450	450	450	450	250	250	250
MinGr	450	450	450	450	450	450	700	700	700
NumGr	no sense			no sense			38	38	38
FirstLife	500	500	500	500	500	500	500	500	500
Life	1100	1100	1100	1300	1600	1700	1500	1600	1700
LimLife	8	8	8	12	12	12	10	12	12
NA1	2	2	2	2	2	2	2	2	2
NA2	7	7	7	7	7	7	7	7	7
NA3	31	13	8	12	7	7	10	7	7
NA4	60	60	60	50	43	43	50	43	43
PA1	20	20	20	20	20	20	20	20	20
PA2	340	320	310	265	240	220	260	245	235
PA3	25	25	25	25	25	25	25	25	25
density	9	9	9	7,5	7,5	7,5	7,5	7,5	7,5
MSE	0,0985	0,0899	0,0846	0,0991	0,0423	0,0316	0,0772	0,0290	0,0286
Mean Error	6%	7%	8%	9%	7%	4%	14%	5%	6%
Mean Error ₂	5%	6%	7%	10%	5%	5%	7%	3%	2%

Table 1: Parameters for the Bucharest's experiments and results expressed as mean square error (MSE) or mean error. Mean error₂ is the mean error calculated without the three first dates (early development). Dark lines are the true parameters (5 or 7), white lines are constant parameters, independent of fertilisation and irrigation.

coherent behaviour of the global canopy (Figure 19), similar to that described by Milford *et al.* (1985b), for the increase of thermal longevity of successive leaves.

4.2.3.2. Effect of water stress

The non irrigated treatment showed severe deficiency symptoms and had a significantly smaller leaf area than control plants. The comparison of the *LAI* dynamics (Figure 20) clearly reveals two levels of stress, firstly with water supply then with nitrogen application. Whatever the nitrogen supply, a treatment short of water gives a significantly lower yield. Indeed, leaf area controls photosynthesis, and our measurements show that the leaf development is markedly affected by water stress. It resulted in a faster growth rate (Figure 18), a shorter life duration (Figure 19) and larger leaves maximum areas (Figure 16). Small amounts of rain falling after prolonged drought, caused large increases in leaf growth of unirrigated sugar beets. These plants temporarily grew faster than irrigated ones that had never been subjected to severe water stress (Milford *et al.*, 1985b). Milford *et al.* (1985c) report similar differences with irrigation for leaves maximum areas, with 150 cm² in the unirrigated crop and 300 cm² in the irrigated one for their 15th leaf 40 cm² and 150 cm² respectively for the 20th.

The model is supposed to simulate potential growth of the canopy, with non-limiting water and nitrogen supplies, then to apply stress corrections according to the respective deficits. The trouble with sugar beets is that under field conditions, plant densities are such that each plant achieves much less than its potential root size: 0.5 to 1 kg rather than 10 kg fresh weight or more (Fick *et al.*, 1975). A relationship between plant density and potential yield (or potential leaf area) is to be defined. Common densities in agriculture range from 9 to 10 plants/m². We only studied potential results with this range of densities.

4.2.3.3. Effect of nitrogen stress

After water supply, an important factor is the response of the crop to varying amounts of available nitrogen in the soil (Webb *et al.*, 1997). The date of application is important, because early absorption of mineral nutrients may occur, with negative effects on germination in case of high concentration (Durr, 1994). Like water stress, nitrogen stress effects arise at different stages of the canopy development, and much more literature exists on the topic.

Leaf apparition rate

For Loomis & Nevins (1963), the rate of new leaf appearance was markedly affected by nitrogen deficiency. In their experiment with adequate nitrogen, 4 ± 1 new leaves appeared per plant each week, for a total of 74 leaves while plants which had been supplied with minus-nitrogen solution in summer, produced only 47 leaves. In our experiment we found no significant difference between the treatments (Figure 15) and the number of leaves was about 60. However the sowing had been delayed because of bad weather conditions and the number of leaves is defined at harvest; but we know that new leaves would appear if harvest was delayed also. Consequently, for a growing season similar to that of Loomis & Nevins, there is no doubt that we would have obtained more or less the same quantity of leaves (more than 70). Concerning the reduction of the number of leaves they observed with nitrogen stress, maybe we started the season with more mineral nitrogen in the soil, leading to a less acute nitrogen stress. Anyhow, no difference was observed between 0 and 300 kg N/ha applied.

Size and shape

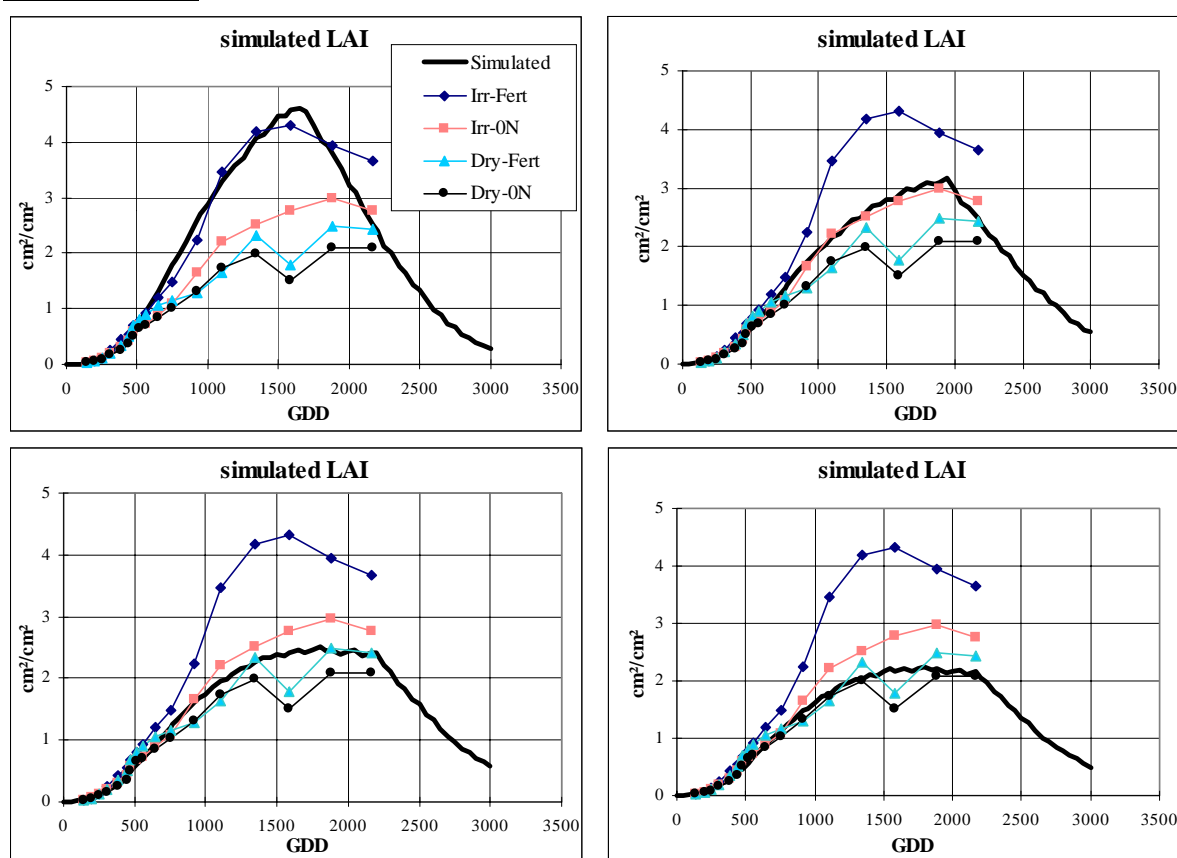

Figure 21: Measured LAI dynamics of the Grignon experiment compared to the model results. The first column presents the simulations with irrigation, and the first row with fertilisation.

Nitrogen application is known to encourage the growth of the shoot (Milford *et al.*, 1985a; Webb *et al.*, 1997). With high nitrogen, Loomis & Nevins (1963) found that the maximum area of leaves 15-20 were typically about twice those attained by later leaves. With our measurements we observed increasing leaves maximum areas with nitrogen supply, and their linear decrease with leaf number after a plateau whose length depends upon the nitrogen supply too (Figure 17). Paradoxically, new leaves appear more rapidly than old leaves die but the leaf area index declines; this is due to a smaller size of new leaves. The decrease in size of the new leaves is more acute for low-nitrogen treatments.

Scenarii Synthesis				
	N300 Irrigated Grignon		N0 Irrigated Grignon	
	N300 Dry Grignon	N0 Dry Grignon		
App	32	32	32	32
MaxGr	250	250	250	250
MinGr	700	700	700	700
NumGr	33	33	33	33
FirstLife	450	450	450	450
Life	1350	1600	1800	1750
LimLife	10	12	14	15
NA1	2	2	2	2
NA2	13	13	13	13
NA3	20	13	13	13
NA4	55	55	45	45
PA1	20	20	20	20
PA2	210	145	135	125
PA3	20	20	20	20
MSE	0,0615	0,0210	0,0384	0,0214
Mean Error	13%	12%	15%	13%
Mean Error₂	9%	6%	12%	7%

Table 2: Parameters for the Grignon experiments and results expressed as mean square error (MSE) or mean error. Mean error₂ is the mean error calculated without the three first dates (early development). Dark lines are the true parameters, white lines are constant parameters, independent of fertilisation and irrigation.

The usual symptoms of nitrogen deficiency (yellowing, small leaves) are foliar characteristics which indicate at least that the gross photosynthetic apparatus has undergone modification (Nevins & Loomis, 1970). Like Loomis & Nevins (1963) we observed that extended nitrogen deficiency results in leaves with short petioles and small, green leaf blades occurring in flattened rosettes.

Senescence

As a response to nitrogen stress, the leaves seem to remain longer on less fertilised plots. The life duration measured was significantly longer with short nitrogen treatments, up to 50%, from 1300 to 1700 GDD_3 (Table 1). This is consistent with Loomis & Nevins (1963), Nevins & Loomis (1970) and Milford *et al.* (1985b) who observed a tendency for leaves which had matured under adequate nitrogen, to undergo earlier senescence as evidenced by yellowing and to die somewhat sooner than when subjected to nitrogen deficiency. In controlled environments, the leaves on N-deficient plants function somewhat longer than do normal leaves.

4.2.3.4. Results with independent LAI data

The sets of parameters were determined using the same method (Microsoft Excel[®] solver) with the French data of Grignon. The results are gathered in Table 2 and Figure 21. The mean errors are higher than those of Bucharest, but the results remain very promising.

The main difference is the maximum *LAI* reached, which is significantly lower in Grignon. It is well known that the expansion of the sugar beet leaf canopy tends to be slow in the north of France; this is an important source of loss of yield. Low temperatures during the early spring slow the initial expansion of foliage, so that much of the large inputs of radiation occurring in May and June are wasted (Boiffin *et al.*, 1992). Another possible source of difference could have been the plant density, but after emergence it was about 9 plants/m², like in the irrigated

The high value of *MinGr* in Grignon means that late leaves grow much slower than the first ones, and this occurs as soon as leaf 15 in Grignon, against leaf 35 in Bucharest (*NumGr*). All leaves in Grignon live more than 1350 *GDD*₃, even with irrigation, when it was only 1100 *GDD*₃ in irrigated conditions in Bucharest. The biggest leaf is the 13th in Grignon and the 7th in Bucharest. Moreover the plateau of the non limiting treatment lasts significantly less (8 leaves instead of 25).

To conclude, the experiments in Grignon, including the one called 'non limiting', behave like the ones in Bucharest with stress conditions. The irrigated treatments in Grignon have parameters very similar to that of the dry treatments in Bucharest, and the stress is still more acute without irrigation. Maybe it was only due to the differences in climate, as emphasised Boiffin *et al.* (1992). Indeed, we found nowhere in the literature *LAI* of 7 to 8 for sugar beets in Western Europe. There is also the possibility of another stress that was not controlled, as initial soil mineral nitrogen content, weeds, diseases or pest control, or a difference of type of soil.

4.2.4. Conclusion

Several mechanistic models (SUBGRO; SUCROS; Patefield & Austin, 1971) have a complex physiological basis, requiring a large number of parameters, yet relying on empirical functions, with no mechanistic basis (Webb *et al.*, 1997). On contrary we chose a mechanistic model with an easy physiological basis, requiring few parameters based on numerous plant measurements. The model was developed and validated with two independent data sets. The results of the preliminary parameterisation fit very closely the experimental points of the six treatments, with only 5 to 7 parameters. The second parameterisation with data from another place (different soil and climate) is consistent with the first one. Most of the parameters are similar and correspond to that of the stressed conditions of the first data set. In addition, all variances between the data sets and parameters were explained and already observed in the literature. This work was adapted to a CERES-Sugar Beet crop model at the French National Institute of Agronomy of Grignon.

4.3. CERES-Beet

4.3.1. Construction

The model CERES-Maize modified at INRA and described in §5-"Models update" was used to develop CERES-Beet. The *LAI* submodel described above replaced *LAI* submodel in CERES-Maize. The phenology has been simplified to sowing, germination, emergence and harvest. There is principally one stage initiated at emergence which continues until a harvest date which is determined in the parameter file. Indeed, contrary to maize and other crops considered in the project, there is no maturity for sugar beet, and no criterion was chosen to determine harvest date.

The crop compartments have been reused or renamed to leaves, leaves blades (previously stems), crowns (previously husks) and roots. Crop characteristics have been adapted with data from literature for radiation interception, conversion to dry matter and repartition to the crop compartments. A nitrogen dilution curve for sugar beet has been used.

4.3.2. Calibration and validation

The calibration was mainly processed with the results of the experiment monitored in Grignon.

The measurements in Grignon mainly focused on leaf area index, in order to validate with an independent data set the model calibrated in Bucharest. The measurements were performed once or twice a week. Each treatment had three plots of measurement with three plants chosen

randomly at emergence. The leaf number was written on the leaf with a unerasable pencil, so that leaves apparition was precisely monitored. The selected leaves (2, 4, 6, 8, 10, 15, 20, 25, ...) were measured until they stop growing. The same formula as in Romania was used with leaves' width and length. Of course we checked the coefficient of Kvêt (1966) and found the same value of 0.77. At harvest only fresh matter, dry matter and nitrate contents by compartment were measured, destructively, on the same plants that had been measured during the growing season. Here are presented the LAI dynamics (Figure 23) and the final yields (Figure 24). As irrigation and fertilisation are applied in order to give the crop the optimal conditions, the first treatment has logically the best LAI and yield. On contrary, the treatment without irrigation nor fertiliser gave the worst results. Between these extreme treatments, effects of water and nitrogen stress can be compared. In the field conditions of Grignon, water stress was more active, but we had no control of initial nitrogen status of the soil.

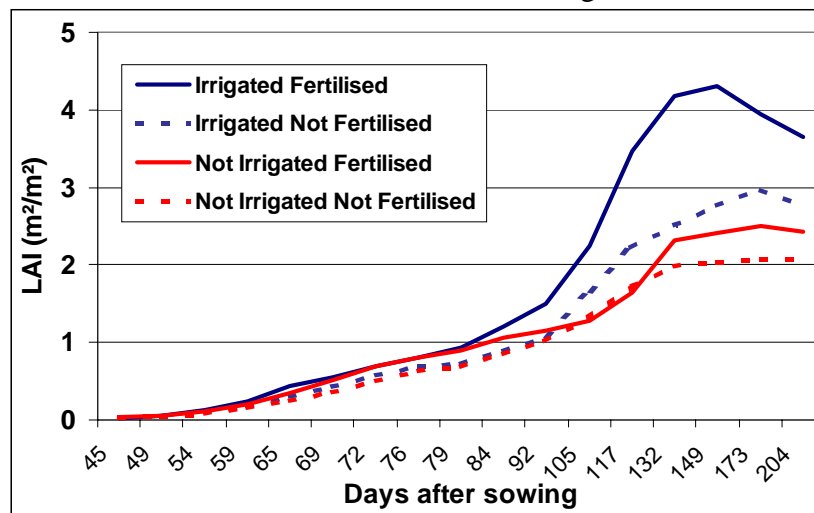

Figure 23: LAI dynamics of the four treatments in Grignon in 1998

LAI did not exceed 4, even in potential conditions, and it hardly reached 3 without fertiliser, which is the threshold for quasi-optimal radiation interception by the canopy. With LAI ranging in 2-2.5 for non irrigated treatments, severe dry matter deficiency was predictable, as confirmed in Figure 24. Dry matter production is markedly affected by the different stress.

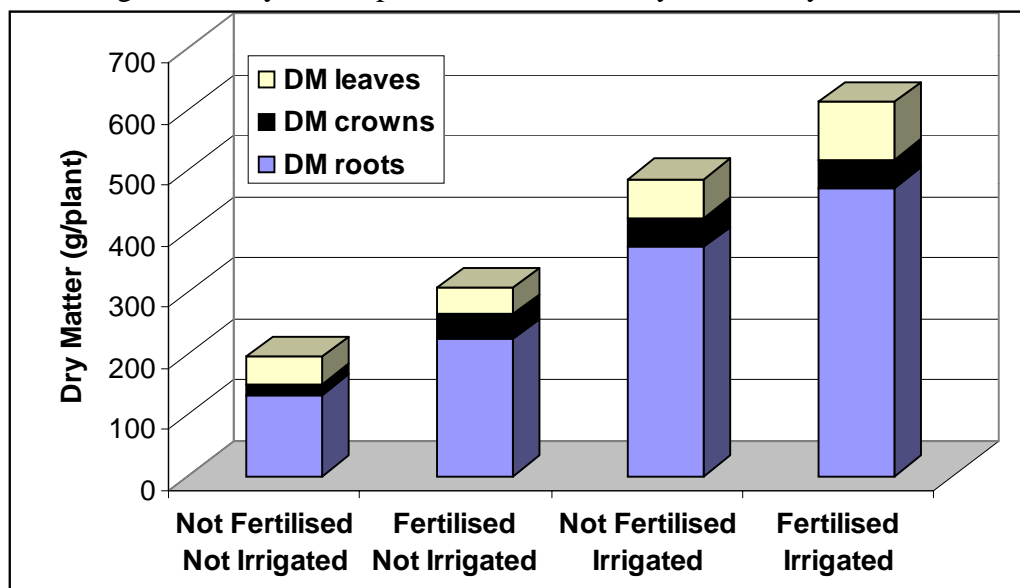

Figure 24: Dry matter of the four treatments in Grignon, and repartition

Conversely the repartition among sugar beet compartments remained steady, as shows Figure 25, as well as sugar content always between 19% and 21% of root fresh matter, with a mean value of $20.1\% \pm 0.6\%$ (Figure 26).

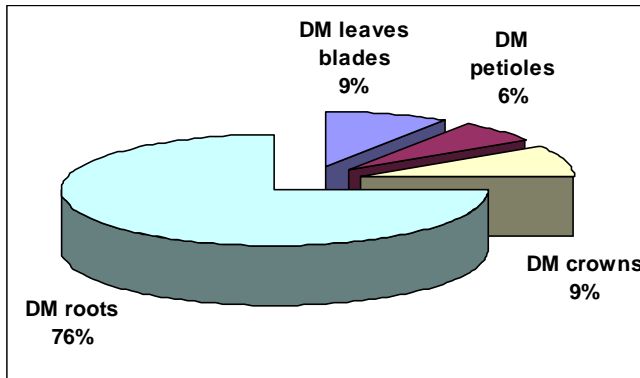

Figure 25: Dry Matter partitioning

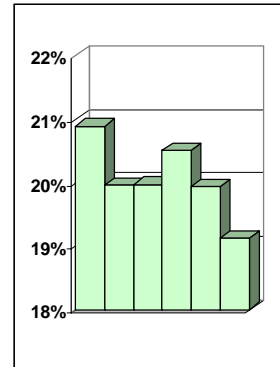

Figure 26: Replicates of sugar content of Roots (% Fresh Matter)

Paradoxically, if dry matter repartition is quite steady whatever the treatment, significant differences were observed in nitrogen contents. Figure 27 illustrates the effect of fertilisation on nitrogen contents in plant compartments. For nitrogen content, water deficit is a secondary factor behind fertilisation. In addition, with fertiliser, a lack of water may increase the nitrogen content. Indeed nitrate is available at a higher concentration because the same amount of fertiliser is applied in less soil water. Then the water stress results in a stress for dry matter production with similar availability of nitrogen. In Figure 27 it is illustrated mainly for petioles and roots. For not fertilised treatments, the water stress effect is very strong, with 30% to 50%-less nitrogen contents in dry conditions.

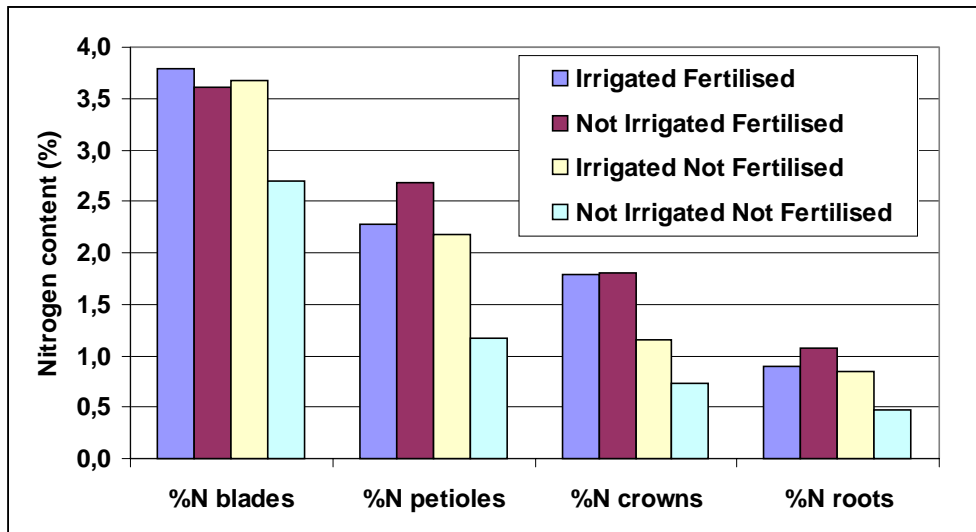

Figure 27: Nitrogen contents in the sugar beet compartments

LAI was already calibrated and validated when the submodel was developed. Only total dry matter and partitioning had therefore to be checked. The repartition keys have been adjusted and validated on two independent data sets. The results are shown on Figure 28. The model was considered operational and integrated in crop rotations with maize, wheat and rapeseed.

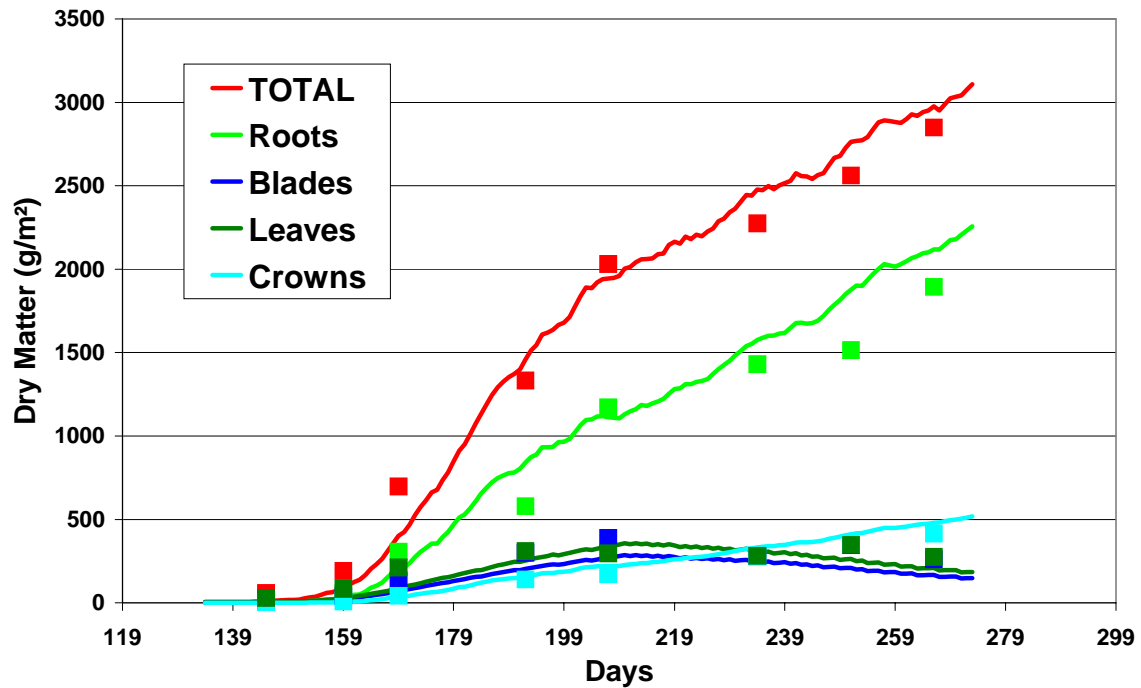

Figure 28: Comparison of model outputs and experimental results for potential conditions in Bucharest

4.3.3. Perspectives

The model is reliable in potential conditions but requires improvement for stressed conditions. Experiments were carried out with different levels of irrigation and fertilisation, but all results could not be valorised yet. An effort should be done to express relations between soil moisture or nitrogen content (or deficiency) and stress factors used to limit leaves expansion and dry matter production.

5. Models update

Environmental balances can be obtained directly from field experiments, but only a finite set of conditions can be studied in this way. A predictive model used to simulate the water-carbon-nitrogen cycle at the heart of the soil-plant system is crucial in assessing the risks due to year-to-year variability in the climate, or for testing the effect of different cultural practices. Our aim here was to obtain coherent models, with reproducible results, by using sound phenomenological data combined with parameterisation methods which are as unambiguous as possible.

On the other hand, this tool for the prediction of the environmental balance must be simple to parameterise with only a minimal amount of calculation for a given site. Its entry variables are limited to routine daily weather data (rainfall, radiation, air temperature, potential evapotranspiration), and to physico-chemical characteristics of the soil (organic matter content, pH, water retention characteristics and bulk density) for each horizon.

This type of models is a valuable tool for sustainable agriculture: it is useful to manage the nutritional supplies, by adapting them to the crop requirement, and to estimate the impacts on environment of some agricultural practices (straws burying, irrigation, type of fertiliser).

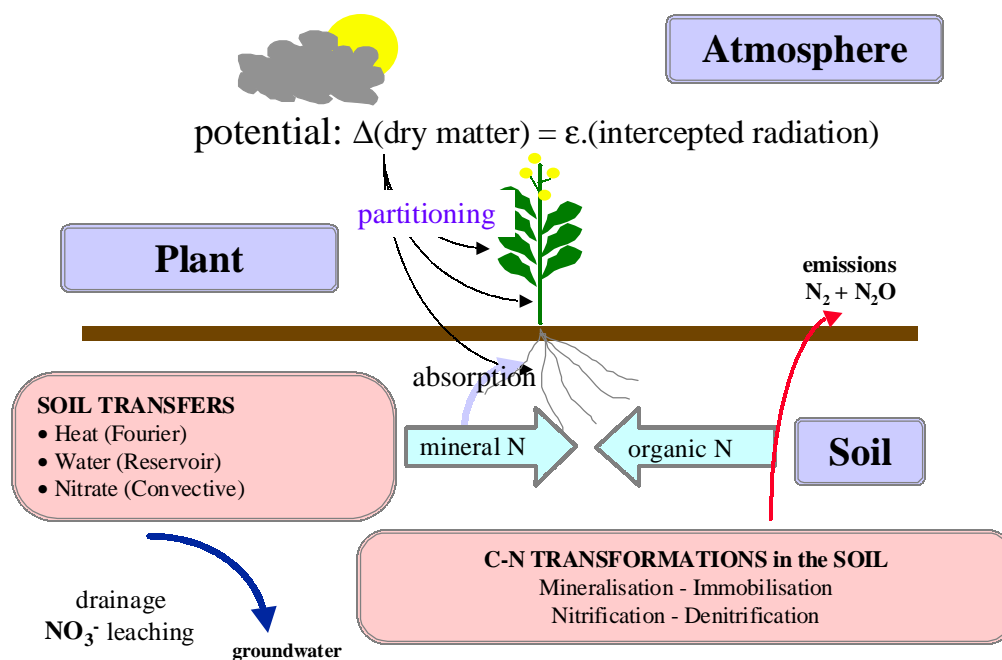

Figure 29: Modelling general background

5.1. Physical bases

Models simulating crop growth were developed, on one hand, to predict the yields, on the other hand, to analyse the impacts of agricultural practices on environment, with therefore a deep interest for the process taking place in the soil.

The crop growth is often described by empirical models such as regressions. The environmental data, such as radiation or rainfall, are commonly present in these regressions; for instance, an easy approach consists in linking the cumulated rainfall during the season to the measured values on a site or in a region. This type of model may lead to reliable predictions, on the condition that the regression parameters were defined from large data sets. Furthermore these predictions are limited to the environment and to the plant genotype from which the regression was realised. These empirical and descriptive models give few

information about the reasons of the observed variations in the measurements. For this reason, we preferred models with a shorter time step (one day maximum) and which took into consideration many physical or biological process.

The mechanistic model CERES was developed in the 80's in the laboratory of the United States Department of Agriculture (USDA) of Temple, Texas. It estimates the crop yields as a function of site meteorology, irrigation, fertiliser treatments and cultivated genotype. A version dedicated to maize already existed (CERES-N Maize), managing the plant nitrogen nutrition. Associated to a model simulating the transfers and transformations of nitrogen in the soil, CERES estimates the pollution linked to the agricultural practices. The aim is to predict yield, in order to optimise it, with economical and environmental constraints.

CERES is mono-dimensional along a vertical axis and operates on a daily time step. It distinguishes phenological development stages, associated to growing degree-days thresholds, either set by the user, or estimated in the simulation. The model is composed of different submodels, each one functioning independently with its own inputs/outputs, and using parameters as represented in Figure 29. The interactions between these submodels take into consideration the main variables of the soil-plant-atmosphere system: soil temperature, air temperature, soil water storage...

This chapter does not pretend to make an exhaustive description of the CERES models, but to describe roughly each stage of the modelling, without reminding every equation used. All the subroutines are adapted from CERES-MAIZE, described by Jones & Kiniry (1986), adapted to various crops by Vardon (1993), Gabrielle (1996), Leviel & Crivineanu (2000b) and Roche.

5.1.1. Soil water

5.1.1.1. Reservoir

Subroutine *WATBAL*'s two principal functions are to calculate the redistribution of water due to irrigation, precipitation and drainage, and to calculate potential evapotranspiration, soil evaporation and plant transpiration.

Irrigation and rainfall are summed. The potential infiltration into the soil is then calculated as the sum of irrigation and rainfall. Drainage and soil water redistribution are calculated next.

A loop is used to move water downward through successive soil layers. If infiltration occurs, the amount of water that the layer can hold between the current volumetric water content and saturation is calculated. If the potential infiltration is less than or equal to it, a new value of the soil water storage is calculated as if this soil water poured in the layer. If this new soil water amount is less than the Drainage Upper Limit (*DUL*), drainage by unsaturated flow from the layer is calculated as the excess of water above *DUL*. A post-drainage value of the layer's soil water storage is calculated, and the potential infiltration for the next layer is set. The loop ends with the estimation of the total flow out of the lowest layer of the soil profile.

5.1.1.2. Capillary rising

The water balance submodel is taken from Gabrielle *et al.* (1995) who have implemented a semi-empirical Darcy's law for water movement in the soil profile in both saturated and unsaturated conditions. It can also simulate upward water fluxes into the root zone from the groundwater table.

5.1.1.3. Transpiration

Subroutine *WATBAL* also contains calculations of potential soil evaporation and potential evapotranspiration. The actual evaporation and transpiration are calculated with the model of Ritchie (1972), then the evaporation is converted to volumetric water content and subtracted from the volumetric water content of soil layer 1. Upward and downward flows of water due to unsaturated flow at soil water contents between the lower limit and *DUL* are now calculated (Jones & Kiniry, 1986). Subroutine of nitrate transfer (*NFLUX*) is called for each layer.

The plant ability to take water up is taken into account in the transpiration calculation. Root depth and density are simulated as described by Vardon (1993). Root depth is the lowest value among the potential depth (linear function of sum of temperatures), the maximum depth allowed by the crop and the maximum depth allowed by the soil. Root density is constant then decreases exponentially until maximum root depth. Root senescence is subtracted and the ammonium pool is updated.

5.1.2. Soil nitrogen

Several process are considered: convective nitrate transfer with water within the profile and downward to groundwater (leaching), uptake by the crop, and chemical transformations in the soil.

5.1.2.1. Nitrate transfer

Subroutine *NFLUX* calculates the downward movement of nitrate with percolating water and both upward and downward movement of nitrate caused by water movement between layers. Nitrate is moved at the nitrate content of the current soil layer.

5.1.2.2. Nitrogen transformations

The submodel for soil C-N transformations is an adapted version of NCSOIL, described in Gabrielle & Kengni (1996). Its parameters may be calculated from the previous CERES parameters, which include soil organic carbon and nitrogen, and the amount of carbon and nitrogen in the unharvested residues of the preceding crop.

As chemical activity is sensible to temperature, a new subroutine for soil temperature from Hoffmann *et al.* (1993) has been included.

Subroutine *MINIMO* calculates mineralisation of organic nitrogen and immobilisation of mineral nitrogen due to crop residue and soil organic matter decomposition. It is based on the mineralisation-immobilisation routine in NCSOIL (Molina *et al.*, 1983; Gabrielle & Kengni, 1996). It also applies fertiliser $\text{NH}_4\text{-N}$ and $\text{NO}_3\text{-N}$ to the appropriate mineral N pools in the soil. The subroutine firstly updates the nitrate and ammonium contents of appropriate soil layers if nitrogen fertiliser is applied. Then the model calculates transformations of soil organic matter and organic nitrogen. Two pools of organic matter are considered in each soil layer. The fresh organic matter in a layer is composed of the root and shoot residues of the previous crop, microbial biomass, and its rapidly decomposing products. The stable soil organic matter or "humus" in a layer is composed of all other organic matter in the soil.

Subroutine *NITRIF* calculates nitrification of NH_4 in each soil layer with the model NCSOIL (Molina *et al.*, 1983; Gabrielle & Kengni, 1996). This process is closely linked to the volumetric water content, to the temperature and to the microbial nitrification potential of the layer. The microbial nitrification potential is calculated each day and updated for the next day's calculations.

Subroutine **DNIT** calculates denitrification whenever the soil water in the layer is greater than **DUL** (Hénault, 1993). No denitrification occurs in a layer if its nitrate concentration is less than 1 g.Mg⁻¹. The equations require calculations of soil moisture content, temperature of the layer. The nitrate content of the layer is updated; it is not allowed to decrease below 1 g NO₃-N.Mg soil⁻¹.

5.1.2.3. Root absorption

The maximum rate of water uptake per unit root length is limited by soil water content (Jones & Kiniry, 1986), and the potential root water uptake from the profile (**TRWU**) is calculated by summing the root water uptakes for all layers. If the potential transpiration is less than or equal to **TRWU**, a zero-to-unity water use factor is calculated, and transpiration equals potential transpiration. Else transpiration equals **TRWU**. Actual soil water in each layer after transpiration is updated. Total soil water in the profile and plant-extractable soil water are calculated. Two zero-to-unity soil water deficit factors used in growth subroutine (**GROSUB**) are calculated: the first one (**TRWU**/potential transpiration) affects photosynthesis, the second one (0.67×**TRWU**/potential transpiration) affects plant cell expansion. Finally, stress factors used to evaluate stress during the various growth stages are calculated.

5.1.3. Crop

5.1.3.1. Phenology

Plant's development is divided into successive stages activated by subroutine **PHENOL**. Crop specific criteria delimit the successive stages. At sowing, emergence date is deduced from daily temperatures and sowing depth. Moreover, dry matter compartments are initialised. According to the stage in progress, different organs are in development at various rates.

5.1.3.2. Dry matter production

Subroutine **GROSUB** calculates leaf area development, light interception, photosynthesis, and partitioning of biomass into various plant parts.

The potential dry matter production (ΔDM) depending upon leaf area index (LAI) and global radiation (Rg) is calculated with:

$$\Delta DM = \varepsilon \cdot (0.95 \times (1 - \exp(-k \times LAI))) \times 0.48 \times Rg$$

where ε and k are crop-specific coefficients for radiation efficiency and light interception, respectively.

This equation implies that leaf interception of photosynthetically active radiation obey Beer's Law. The allowed-by-nitrogen dry matter production is also calculated and depends on total available-for-roots nitrogen in the profile, a value calculated by subroutine **NUPTAK**. The actual dry matter production is the lower of allowed-by-radiation and allowed-by-nitrogen productions.

The plant vegetative dry matter amount and the specific plant vegetative dry matter are updated. The dry matter production is split into roots and aerial parts, and the corresponding dry matter compartments are updated.

5.1.3.3. Stress effects

For many process, potential values are firstly calculated, then stress factors, calculated in the constraints submodel, and ranging from 0 (maximum stress) to 1 (no stress) may reduce this

potential value in case of water or nitrogen stress. So the actual values are deduced from the potential values.

For instance, subroutine *NUPTAK* calculates the demand of nitrogen by the crop, and the supply available to the crop. Roots and aerial requirements are separately estimated. Total requirement is majored by the available-for-plant nitrogen in soil. The stress factor 'demand/available ratio' is calculated. Nitrate and ammonium uptakes in each soil layer are calculated from this factors. Then the nitrogen amount increase in the plant's compartments is computed.

5.2. Program structure

The program can be installed in any computer directory, on the condition that input and output files are present in the same directory. Four input files and 6 to 8 output files (according to the crop) are required.

5.2.1. Inputs

The first file deals with the soil parameters and the agricultural practices. It can be divided into 4 parts:

⊕ Management and miscellaneous parameters:

Current crop: depth and density of the sowing, location latitude, basis factor of the mineralisation rate, time intervals for results outputs, irrigation and fertilisation switches.

Location and previous crop: bare soil albedo, superior threshold of evaporation, drainage coefficient, surface flow parameter, mean annual temperature, annual thermal amplitude, first day of simulation, weight of the previous crop's straws, straws burying depth, straws C:N ratio, weight of the previous crop's root residues, root residues C:N ratio.

⊕ Soil (each line describes a soil layer):

Thickness, wilting point, field capacity, saturation, new root distribution factor, initial water storage, organic carbon content, bulk density, pH, ammonium and nitrate storage.

⊕ Irrigation: each line includes the date and amount of an irrigation.

⊕ Fertilisation: each line includes the date, the amount, the introduction depth and fertiliser type of a fertilisation.

The second file deals with the weather data.

Each line includes the date, the direct radiation, the minimum and maximum temperatures, the rainfall, the sunshine duration and the potential evapotranspiration. The two latter are set to -1 if measurements are not available. In such cases, the missing values are calculated by the subroutines *SNDUR* and *WATBAL* respectively.

The third file contains residues and NCSOIL parameters (see 5.1.2.2 and 5.3.3.3.).

These files may be named without constraints by the user. By convention, '.par' extension is used for soil parameters, '.met' for weather data and '.ncs' for NCSOIL.

The fourth file indicates to the main program the names of the 3 input files.

5.2.2. Outputs

• OYLD.DAT

⊕ Several input data are reminded: title, cultivar, initial density, and data concerning the soil (each layer's hydric capacities, water and nitrogen initial conditions), the irrigation (dates and amounts) and the fertilization (dates, type and amounts).

⊕ The simulation results are, for key dates between sowing and maturity: dry matter amount, leaf area index, plants' nitrogen content, crop's actual evapotranspiration, plant transpiration and water available for the crop. Rainfall and irrigation are joined to these data.

• OBIO.DAT

This output file includes periodic data about the produced biomass: date, leaf area index, dry matter of each plant compartment (roots, leaves, stems, ...), root depth and root density.

• OWAT.DAT

This output file includes periodic data about crop and soil water: date, mean plant's transpiration, mean actual evapotranspiration, mean potential evapotranspiration, mean solar radiation, mean temperatures, mean rainfall, instant water storage in the soil layers and total available water in the area reached by the roots.

• ONIS.DAT

This output file includes periodic data about organic and inorganic soil nitrogen: date, mean amount of organic nitrogen immobilised, mean amounts of nitrogen mineralised from fresh and humic organic matter respectively, nitrate and ammonium storage in the soil layers.

• OMIN.DAT

This output file includes periodic data about the nitrogen balance for each layer: date, organic matter decomposition, nitrate and ammonium contents, nitrification, leaching, nitrogen vertical fluxes and plant uptakes.

• ONIP.DAT

This output file includes periodic data about the nitrogen in the plant: date, actual mean nitrogen content of the entire plant, mean threshold content of the entire plant, instant nitrogen requirement of the crop, cumulative nitrogen uptake by the crop since emergence, instant nitrogen amount in the aerial parts, instant nitrate and ammonium amounts in soil.

5.2.3. Global flow diagram

- All common variables declaration. Keyboard interrogation for parameters and meteo files. Opening of the necessary files.
- Subroutine **RDPARA** reads crop parameters files.
- Subroutine **PROGRI** initialises the simulation.
- The meteo file is read until the simulation beginning's date.
- Subroutine **SOILRI** initialises soil water conditions.
- Subroutine **SOILNI** initialises soil nitrogen conditions.
- One line back in the meteo file to begin the simulation at the accurate date.
- Beginning of the line-by-line reading of the meteo file.

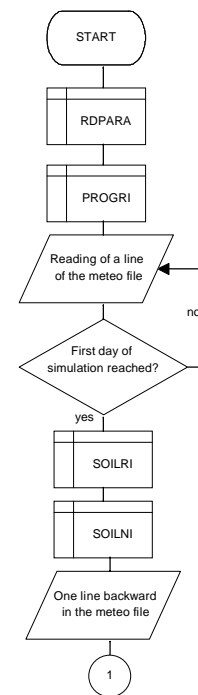

- Reading of the meteorological data of the current day.
- Daily direct radiation conversion to $\text{MJ}\cdot\text{m}^{-2}\cdot\text{day}^{-1}$
- If the sunshine duration is not recorded in the meteo file, the subroutine **SUNDR** calculates it.
- Subroutine **MINIMO** adds the fertiliser to the soil and simulates the mineralisation and immobilisation process.
- Subroutine **WATBAL** simulates the water and nitrate transfers in the soil.
- Subroutine **PHENOL** simulates the crop's development.
- Subroutine **GROSUB** simulates the mean plant's growth.
- Subroutine **NWRITE** modifies the nitrogen data in output files.
- Subroutine **WRITE** modifies the water data in output files.
- Next line if neither the simulation nor the meteo file ends.
- All open files are closed.

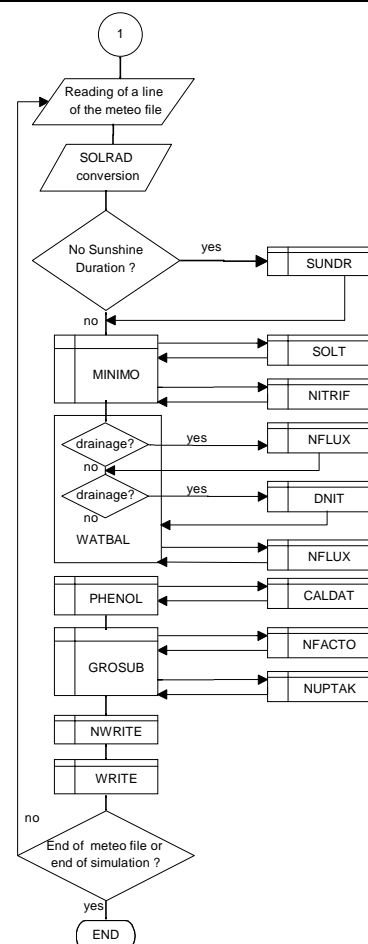

5.3. Utilisation

5.3.1. Parameterisation

5.3.1.1. Water balance

The **water flow submodel** requires three additional soil parameters, as compared to the original CERES model. They characterise the hydrodynamic properties of the soil, i.e. the suction and hydraulic conductivity curves, using the following equations:

$$K(\theta) = K_0 \cdot \exp[A(\theta - \theta_{sat})]$$

$$\varphi(\theta) = \exp\left[\frac{\log\left(\frac{\theta_{sat}}{\theta}\right)}{\gamma}\right]$$

Where φ is the matric suction (cm water), K the hydraulic conductivity, and θ_{sat} the volumetric moisture content. In addition:

- parameter γ (cm⁻²) is a texture related constant that accounts for the soil's suction curve (see Table 3, from Driessen (1986).
- parameter A (unitless) depends on soil texture and hydrologic classes. For a loamy soil, it ranges from 20 (poorly drained soil) to 50 (well drained soil); for a sandy soil, it can be set around 80; for a clay soil, it can go up to 200. Literature data are rather scarce, on this matter, however.
- as a last parameter, the saturated hydraulic conductivity K_0 (cm day⁻¹) is expected to be evaluated on site.

In the current version, the soil profile has been stratified into two horizons as regards hydraulic properties: the top- and sub-soil, corresponding to the 0-30 cm and >30 cm layers, respectively. The corresponding sets of parameters are noted (K_0 , A , γ) and (K_{02} , A_2 , γ_2), respectively. A soil with constant properties across the profile is simulated with identical sets. Many of the above parameters may be inferred from soil texture, bulk density, and carbon content by means of pedo-transfer functions. The software package SOILPAR, by Marco Donatelli (ISA Modena, Italy) provides several of these functions, along with some helpful guidance. It is available from Washington State University.

It is possible to take groundwater contribution into account, if the table depth is known. Tables in Driessen (1986) provide coefficients giving capillary rise flux depending on soil texture and root zone depth.

Texture class	γ cm^{-2}
coarse sand	0.1000
fine sand	0.0288
loamy sand	0.0330
fine sandy loam	0.0207
silt loam	0.0185
loam	0.0180
loess loam	0.0169
sandy clay loam	0.0096
silty clay loam	0.0105
clay loam	0.0105
light clay	0.0085
silty clay	0.0065
heavy clay	0.0042

Table 3: Indicative values of γ for various soil texture classes (Driessen, 1986)

5.3.1.2. Heat balance

The **heat flow submodel** requires two parameters (Hoffmann *et al.*, 1993):

- the soil's yearly average thermal conductivity (λ_{av} in $\text{J cm}^{-1} \text{K}^{-1} \text{day}^{-1}$)
- the soil's yearly average moisture content across the profile (θ_{av} in cm^3/cm^3)

They only affect the simulated temperature course at the bottom of the soil profile.

5.3.1.3. Soil bio-transformations

The **denitrification submodel** is driven by the Potential Denitrification Rate (PDR), which is site-specific. PDR is expressed in $\text{kg N ha}^{-1} \text{day}^{-1}$. It approximately ranges from 0.05 to $5 \text{ kg N ha}^{-1} \text{day}^{-1}$. Hénault *et al.* (1996) found a weak but significant relationship of PDR with bulk organic C content, which reads: $\text{PDR} = 1.174 (\text{OC} - 1) \times \text{DLAYR} / 100 \times \text{BD}$ where OC is organic C (in %), DLAYR is layer thickness (cm), and BD is bulk density (g/cm^3) for the topsoil (0-20 cm layer, typically).

The **soil organic matter component** in NCSOIL involves three endogenous organic matter (OM) pools, numbered pool I, II and III, respectively. Pool I is the microbial biomass, which is sub-divided into resistant and labile fractions (the ratio of labile to resistant fractions being usually taken as 0.42). Pool II is the 'active' OM (also referred to as 'humads'), and pool III comprises the rest of soil OM. It is possible to measure the size of the microbial biomass (pool I) by fumigation-extraction techniques, and to infer that of pool II from laboratory incubations of soil samples (e.g., Nicolardot & Molina, 1994). However, in case such data are not available, Houot *et al.* (1994) suggested to estimate them from total soil organic carbon, with the following relationship:

- pool I makes up 0.9% of total soil carbon, with a C/N ratio of 10
- pool II makes up 14% of total soil carbon, with a C/N ratio of 20

Fresh OM (that comes from the preceding crop's residues) comprises three pools (carbohydrate, cellulose, and lignin-like), as suggested by Godwin & Jones (1991) in CERES. These authors used proportions of 20%, 70%, and 10% of total carbon in the residues for the carbohydrate, cellulose, and lignin-like pools, respectively, as shown in the example NCSOIL input file. The file also shows the standard decomposition rates associated with these pools. The fresh OM pools may then be parameterised as a function of the total carbon that is returned to the soil after harvest, and from the bulk C/N ratio of these residues.

5.3.1.4. Weather file

The weather file is an usual CERES one, except that it is possible to include measured values of Potential EvapoTranspiration (mm/day) and day length (hours - needed in the phenology module). If not available, these latter values may be input as '-1.00'. The code reads the following daily variables:

iy, **jdate**, **solrad**, **tmax**, **tmin**, **rain**, **daylength**, **PET**
with the FORTRAN format (**7X,I2,1X,I3,3X,F4.0,3F6.1,F7.2,F6.2**).

5.3.1.5. Soil and management file

Here is an example file (Grignon 1989 maize experiment in Gabrielle *et al.*, 1995). It is essentially the same as the management file of CERES-Maize (Jones & Kiniry, 1986), where the names of the input variables are explained. The changes with CERES-Maize are commented in bold font.

The new parameters **alfa**, **γ** , **A**, **K_0** , **λ_{av}** , **θ_{av}** and **PDR** appear in this file (with **K_0** replacing SWCON):

```
grigno 89 SW=LL, misajour 18/2/99
106 08.00 02.50 49.00 4.30 01 01 01 01 01 1.00 1.20
dea 220. .000 950. 600.0 10.00
```

these first three lines go unchanged

```
.12 5.0 4.5 5.0 25.0 .01850 00.0 10.0 16.0 031 09000 25.0 110.0 01125 110.0 12.0
```

the above line contains SALB U alfa K_0 A γ CN2 TAV AMP JDATE STRAW SDEP SCN ROOT RCN CNTOT (see below Table 4 for the meaning of these variables).

```
260. .240 6.0 5.00 25.0 .0185
```

the above line is additional and contains λ_{av} θ_{av} PDR, K_{02} , A2, γ_2

the rest is unchanged compared to the CERES-Maize input file

```
15.0 .133 .300 .450 1.00 .310 1.20 1.33 6.90 00.1 04.0
15.0 .133 .300 .450 0.80 .310 1.20 1.33 6.90 00.1 04.0
30.0 .153 .320 .490 0.60 .330 0.60 1.53 6.90 00.1 02.1
30.0 .190 .280 .480 0.35 .300 0.01 1.46 6.90 00.1 02.6
30.0 .195 .250 .450 0.20 .250 0.01 1.50 6.90 00.1 02.7
0000
000
160 300.0 30. 05
000
```

NB: there is an additional '06' fertiliser type which corresponds to a solution of 50% ammonium nitrate and 50% urea

Name	Description	Unit
CN2	Runoff curve number (from USDA's Universal Soil Loss Equation) range: 0-100	unitless
TAV	Average monthly air temperature	°C
AMP	Amplitude of monthly air temperature series (max-min)	°C
JDATE	Sowing date	Day of year
STRAW	Amount of above-ground material returned to the soil after harvest (includes straw and chaff)	kg dry matter/ha
SDEP	Depth of straw incorporation (into the soil)	cm
SCN	C:N ratio of above-ground material	Unitless
ROOT	Amount of below-ground material returned to the soil at harvest	kg dry matter/ha
RCN	C:N ratio of below-ground material	Unitless
CNTOT ¹	C:N ratio of bulk soil	Unitless

¹ CNTOT also acts as a switch for the parameterisation of soil organic matter pools: if you set it to -1.00, then the value of variables STRAW, SDEP, SCN, ROOT, and RCN will be disregarded and the programme will use instead the values listed in the soil organic matter file for the various pools. Otherwise, the programme will compute the characteristics of these pools from the above set of variables.

Table 4: Glossary of variables

5.3.1.6. Soil organic matter file

This input file is the same as that used with original versions of **NCSOIL**, the new organic matter routine linked within CERES. The only parameters which you may need to adjust are the sizes and C/N ratio of the organic matter pools, which are in bold characters.

Equations are available to parameterise these pools from total organic carbon and from the amount of dry matter (in straw, roots, stubble..) that is returned to the soil after harvest. It is also possible to take tillage management into account .

Example file:

```

Time steps
0 1 90 1
Pool sizes, in mg C/kg soil in 0-30 cm: pool I (labile), pool I
(resistant), pool II, [NU], pool III, [NU],[NU], total soil OM
209. 314. 3744. 0. 15633. 0. 0. 19900.
Decomposition rates of pool I (labile), pool I (resistant), pool II, and pool III (day-1)
0.332 0.0404 0.006 0.16 1.0E-5 0. 0.

0.6 0.6 0.6 0. 0.
0.2 0.2
C/N ratio of pool I, pool II, [NU], [NU], [NU], of bulk soil OM
6 21.3 100 100 100 13.35

0. 0. 0. 0. 0.

0. 0. 0. 0. 0.
Residue pools, in mg C/kg soil in 0-30 cm: carbohydrate,
cellulose, and lignin-like pools, [NU]
0126.0 400.0 50.0 0.
Decomposition rates of the residue pools
0.2 0.05 0.0010 0.

0. 0. 0. 0.

0.6 0.6 0.6 0.

C/N ratio of residue pools

```

120. 120. 120. 0.

0. 0. 0. 0.

0. 0. 0.

Rates

20. 0.0 0.

Inorganic N

0. 4.0 0.

0. 0.

Hypotheses: xn, xnn, xnnn, xdm, xco2,aer,till

1 2 1 1 1 1 0 1

Reduction factor

1.

Zymogenous population

1. 1.

.332 0.0404 1. 0.6 0.2 6.

0.

Nitrifiers

0. 0.

0.1 1. 1. 0. 6.

0.

0. 0.

Initial CO2

1000. 1000.

0.

Input interval

1

End-Exp1_Tr2 SW=SPEC, IRR, FERT

5.3.2. Global interfacing with Excel

Excel software was chosen because of its wide diffusion and of its powerful macro-commands possibilities. All the partners involved in the project could use it and were taught the bases of macro-commands.

5.3.2.1. Principle and functioning

The aim was to reduce software manipulations and problems linked to opened files when CERES is run. Before the development of a global interfacing with Excel, the code could be used either in DOS, really not user-friendly, or with Visual Fortran, the programming environment, more user-friendly but with two major risks:

- unintentional change in the code,
- frequent system error due to running with opened input or output files

With the Excel control panel developed in INRA-Grignon represented in Figure 30, all manipulations are simplified and these risks are skipped. Indeed no code edition is possible, for the code execution is totally independent from Visual Fortran, and status of required files is checked before running the code.

In addition, all crops can be simulated, and any file edited with one click. When the control panel opens, a specific toolbar is activated on the right side of the screen, with shortcuts to

main functions of the control panel. Help files can be opened with buttons on the left or in the specific toolbar.

Blue cells point input/output file names, red cells list available codes, and black cells inform on working directory for each code.

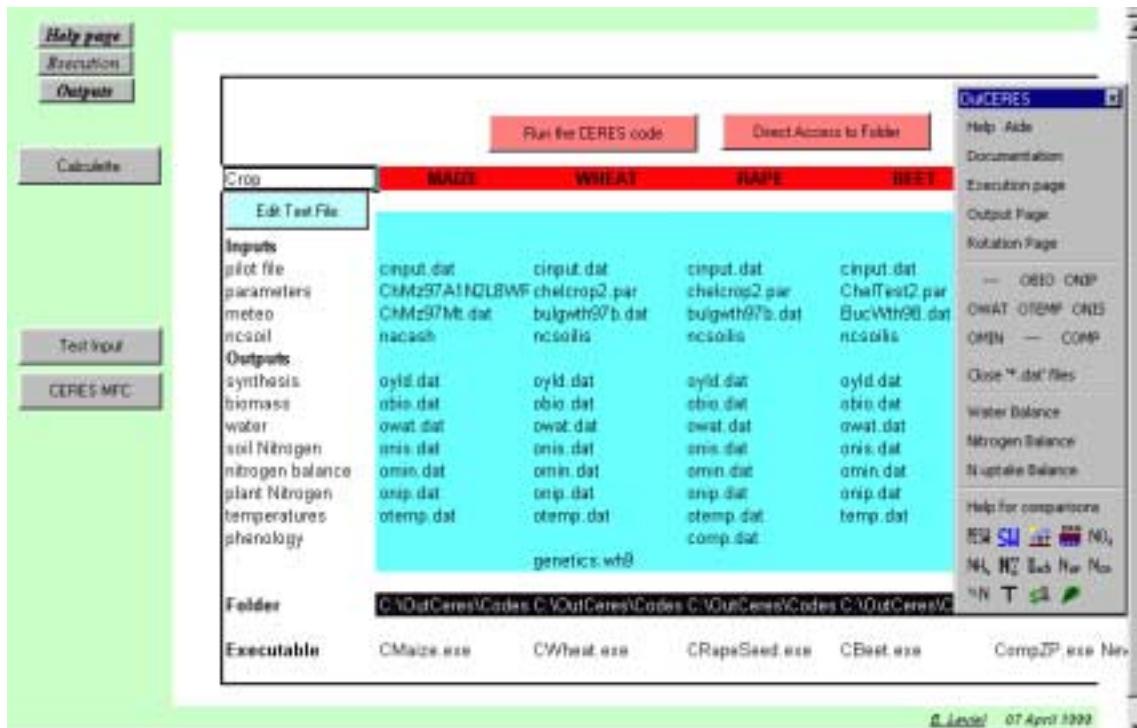

Figure 30: CERES execution control panel

5.3.2.2. Tools diffusion

The CERES codes and environment are updated and diffused via Internet at: <http://www-egc.grignon.inra.fr/ecobilan/cerca/source.html> represented in Figure 31.

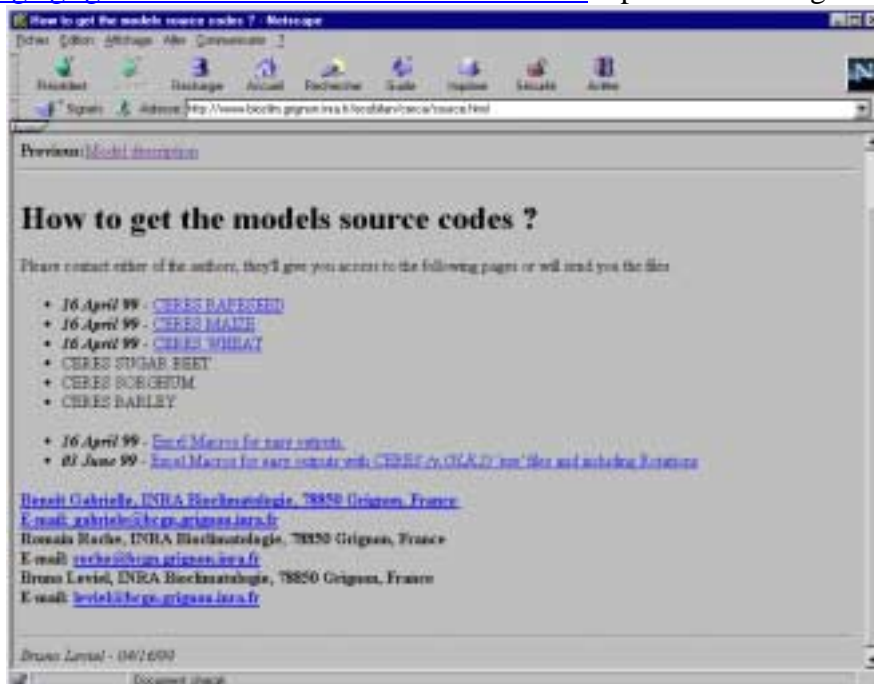

Figure 31: Internet download page for CERES codes and associated tools

These links are accessible only by the project partners during their development and until publication. Then access will be free on request to INRA-Grignon.

5.3.3. Input parameters management

5.3.3.1. Parameters file

Fortran data treatment is very restrictive. Data must be expressed and organised precisely in the input files. A one-space error in a line may turn wrong the simulation. Consequently INRA-Grignon developed an editor to check the parameters file structure, and modify or create such a file. Help files are included in the application. The editor is shown in Figure 32, with its fields for soil and management description. To create a new file, give different names to source and destination. To modify a file, give same source and destination names, but an alarm is displayed to warn about the risk of loosing information.



Figure 32: Editor for CERES parameters files

This editor could be improved with data control during edition and information about units, orders of magnitude, existing data and texture-based estimation of some parameters.

5.3.3.2. Meteo file

As said just above, Fortran data treatment is very restrictive. Data must be expressed and organised precisely in the meteo files too. Data are always available in spreadsheets, but the conversion to a CERES meteo file is not obvious. On contrary it is time consuming and source of mistakes. Therefore INRA-Grignon developed an automated conversion from Excel to CERES, shown on Figure 33. The Excel source must obey certain rules explained in the included help file and a model is downloaded together with the application. The data can be checked with the 'source viewer' before creating the destination file.

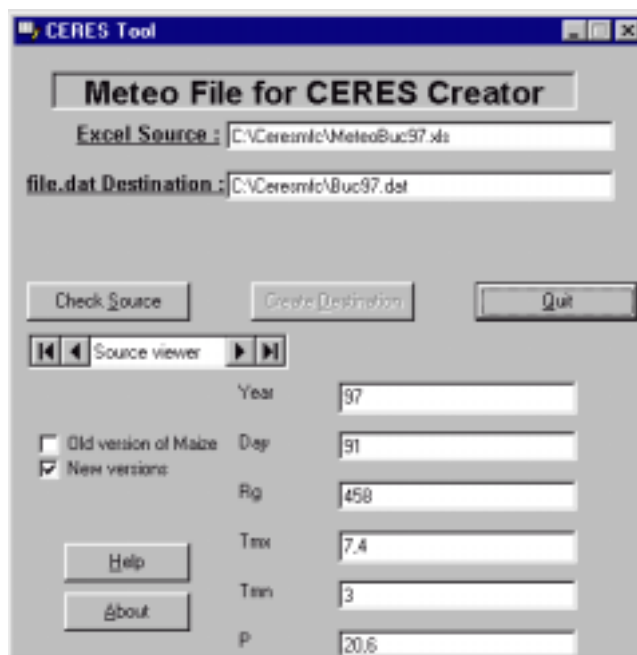

Figure 33: Software converting meteo data from Excel to CERES format

5.3.3.3. NCSOIL file

In most cases, the NCSOIL file is not modified. Within this COPERNICUS project we did not change it, so nothing special was done to edit it.

5.3.3.4. 'cinput.dat' file

This is a three-line file that can be edited through the control panel (Figure 30) where it is located in the 'pilot file' line. It can be directly modified by the user in the control panel, or created by a button with the three names just below in the control panel (parameters, meteo & ncsoil).

5.3.4. Outputs visualisation

The CERES outputs are text files that may be imported into any spreadsheet software. Some macros for reading and plotting the outputs with Excel have been designed.

5.3.4.1. Outputs as 'text' files

Through the control panel or with the computer file manager in the working directory, every output file can be edited as text like in Figure 34.

Each output file has the same aspect: one or two lines with the columns names, then units. One blank line, then daily outputs, from beginning to end of simulation for soil outputs, from sowing to harvest for plant outputs.

This kind of representation is limited because neither calculation nor representation can be performed easily. Export to spreadsheet is useful but repetitive and time consuming.

5.3.4.2. Outputs as Excel spreadsheets

One click on the selected output in the specific toolbar of the control panel automatically opens the text file, imports it in Excel, sets fonts and colours to clearly indicate labels, units and data, and generates charts with colours corresponding to those in the data sheet. Figure 35 shows the results of OBIO, as in Figure 34, but after the treatment of the macro-command of the control panel. The source file is displayed (here E:\CeresUn\Rape\New\obio.dat), and

several sheets were created, grouping and plotting data, for instance here organ weights in 'ORGANS', leaf area index and number of leaves in 'LEAVES', and root depth and length density in 'ROOTS'.

DAY	SDTT	STAGE	LEAFNB	PLANT	LAI M2/M2	ORGAN WEIGHT			
						TOT	ROOT	STEM	LEAF
268	15.60	1	1	50.97	0.00	1.63	0.41	0.82	0.41
269	31.25	1	1	50.97	0.00	1.63	0.41	0.82	0.41
270	45.75	1	1	50.97	0.00	1.64	0.41	0.82	0.41
271	58.50	1	1	50.97	0.00	1.65	0.41	0.82	0.43
272	71.15	1	1	50.97	0.01	1.69	0.41	0.82	0.46
273	84.35	1	1	50.97	0.01	1.74	0.41	0.82	0.51
274	96.65	1	1	50.97	0.01	1.77	0.41	0.82	0.55
275	109.45	1	2	50.97	0.01	1.83	0.41	0.82	0.61
276	120.95	1	2	50.97	0.01	1.86	0.41	0.82	0.64
277	127.45	1	2	50.97	0.01	1.98	0.48	0.82	0.69
278	133.40	1	2	50.97	0.01	2.08	0.53	0.82	0.73
279	139.60	1	2	50.97	0.01	2.22	0.62	0.82	0.78
280	145.80	1	2	50.97	0.01	2.35	0.70	0.82	0.84

Figure 34: CERES output as text

DAY	SDTT	Stage	LEAF NO.	Plants	LAI M2/M2	TOTAL	ROOT	ORGAN WEIGHT STEM	LEAF
268	15,6	1	1	50,97	0	1,63	0,41	0,82	0,41
269	31,25	1	1	50,97	0	1,63	0,41	0,82	0,41
270	45,75	1	1	50,97	0	1,64	0,41	0,82	0,41
271	58,5	1	1	50,97	0	1,65	0,41	0,82	0,43
272	71,15	1	1	50,97	0,01	1,69	0,41	0,82	0,46
273	84,35	1	1	50,97	0,01	1,74	0,41	0,82	0,51
274	96,65	1	1	50,97	0,01	1,77	0,41	0,82	0,55
275	109,45	1	2	50,97	0,01	1,83	0,41	0,82	0,61
276	120,95	1	2	50,97	0,01	1,86	0,41	0,82	0,64
277	127,45	1	2	50,97	0,01	1,98	0,48	0,82	0,69

Figure 35: CERES output imported in Excel

5.3.4.3. Comparison to data observed

The models calibration or validation requires quick comparison of experimental results and models' outputs. For this purpose, some synthetic results must be gathered in specific files. A template was given to all partners (it is downloaded with the models). Such a file is shown in Figure 36. Comments in line 2 precise the units or particular instructions. There are 5 sheets: Soil Water, Soil Nitrogen, Crop Nitrogen, Crop Dry Matter and Soil Temperature.

day	layer1	layer2	layer3	layer4	layer5	layer6	layer7	layer8	PESW	ET
2	126	15,6	20,0	20,0	20,0	20	20,0	20,0	20,0	0
4	126	29,3	27,5	27,5	28,8	26,8	28,0	28,0	26,2	103
5	126	32,7	30,7	29,8	25,0	25	25,0	25,0	25,0	94
6	126	37,0	37,0	37,0	31,8	31,8	31,8	31,8	30,0	169
7	162	22,1	20,7	19,7	23,8	23,76	8,8	8,8	24,2	-6
8	180	23,7	25,9	21,5	23,0	23,03	23,9	23,9	26,2	53
9	195	22,1	25,8	26,4	24,7	24,69	26,9	26,93	28,7	76
10	206	21,4	24,0	21,9	24,6	24,58	23,1	23,1	26,0	50
11	234	23,3	25,6	27,1	26,2	26,21	24,3	24,33	19,0	61
12	244	17,8	21,8	23,9	25,4	25,37	24,4	24,4	26,0	50
13	255	12,4	27,2	27,9	23,7	23,69	24,5	24,45	27,3	53
14	268	9,7	20,3	24,8	22,0	22,03	21,6	21,6	23,6	15
15	279	21,7	21,4	22,3	26,5	26,5	27,0	27	26,7	66

Figure 36: Experimental data collection for comparison to CERES simulation

With the experimental data file opened and activated, comparison to the current CERES simulation is possible through bottom part of the specific toolbar (see Figure 37). The icons represent the data that can be used for comparison. Follow the instructions or see help.

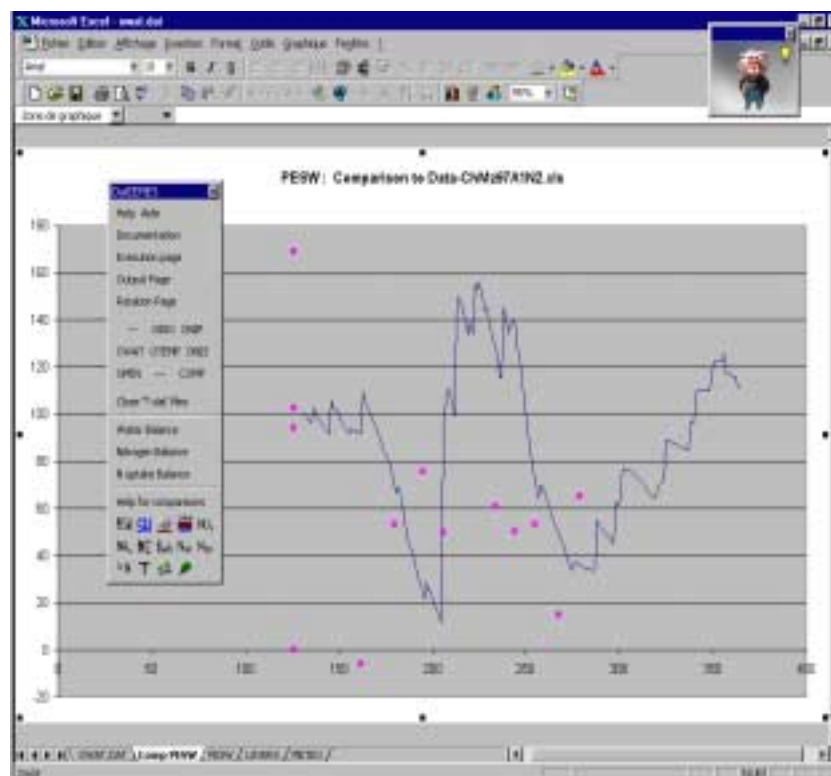

Figure 37: CERES output converted in an Excel graph, with comparison to field data

Statistic calculation can be performed from these comparisons, as shown in Figure 38.

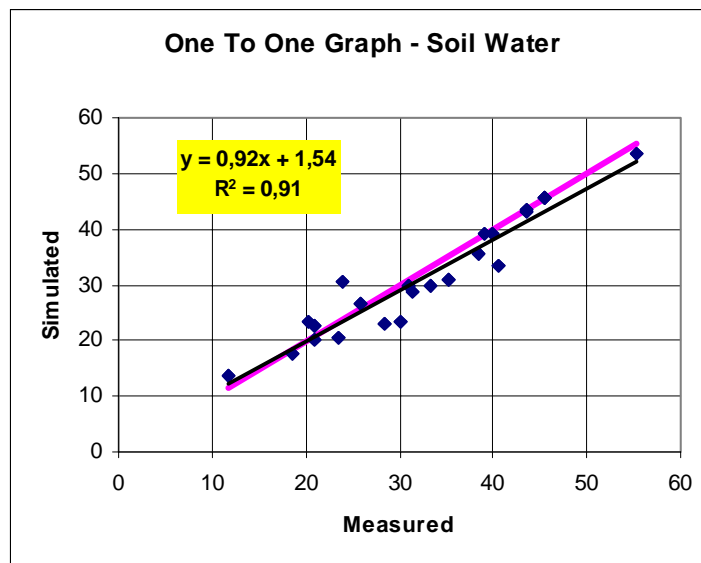

Figure 38: Linear regression from comparison of field and simulated soil water contents

5.3.5. Simulation of crops rotations

Once the different models run individually, nothing prevents from using them successively. This is the main interest of this kind of models, in order to investigate middle-term or long-term effects on yields and on environment of some field management and/or crop rotations. This is feasible on the condition that harvest soil conditions are used as initial conditions for the following simulation. Once again this is not as easy as it seems because the CERES input files modifications require a lot of attention and are time consuming.

5.3.5.1. Same crop with bare soil between harvest and next sowing

This is the easiest situation. Indeed, as long as meteo data are available, the model keeps simulating soil behaviour. Each time sowing date is reached a new sowing is done and so on.

5.3.5.2. Rotations of several crops

As soon as different crops must be simulated, new input files must be created at harvest to start a new simulation with another code. Final soil moisture and nitrogen contents are converted to initial profiles. Harvest products are converted in residues.

To facilitate these operations, save time and reduce risks of errors, a 'rotation control panel' was developed by INRA-Grignon. It is constituted of two sides as shown on Figure 39. Running a rotation requires several output files, and therefore a **project** is defined and a special folder is created on the computer hard disk. The right side of the 'rotation control panel' must be completed before beginning the simulations. It describes the successive crops, with meteo file names, sowing dates, densities and depths, fertiliser and irrigation management.

The left part runs the successive simulations step by step. Of course some help is available, but the macro-commands are programmed to activate the accurate cell for next step.

Usual output files are created for each simulation, in addition to global output files gathering all results from year 0 to final year.

A catch crop will be simulated with oilseed rape harvested or mulched before the following crop.

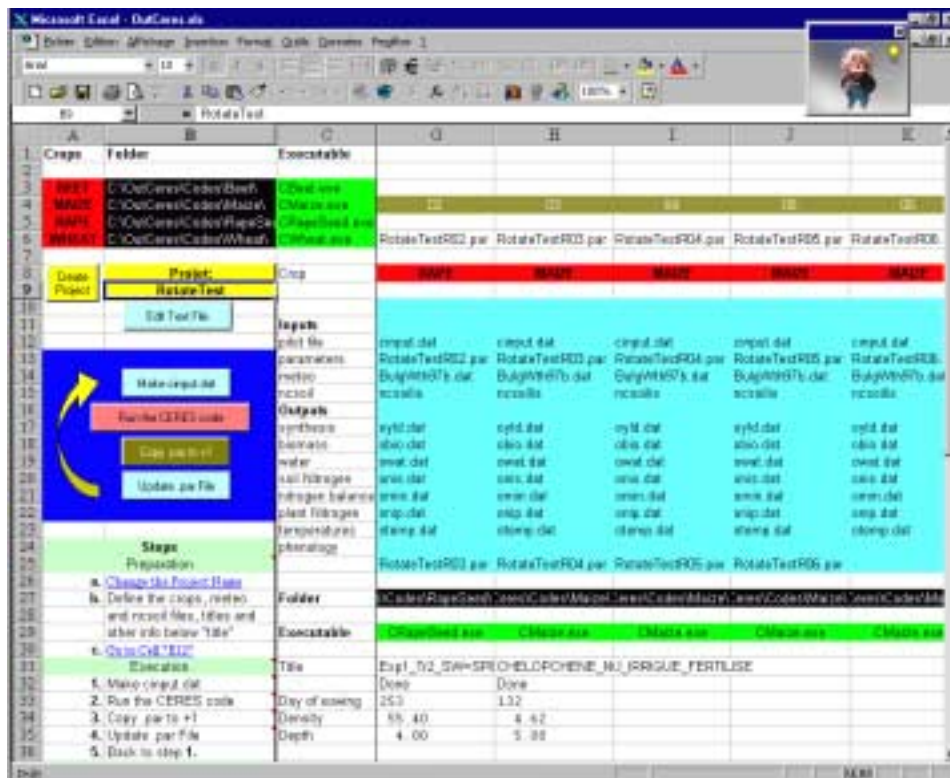

Figure 39: Rotation control panel

5.4. Modifications within the project and limits

We have presented above modifications in the use of CERES models, but many changes within the source codes were necessary. There were two kinds of corrections: “style“ or “functioning”. We called “style” corrections when format were corrected to have similar files whatever the crop simulated. We called “functioning” corrections when differences in physical processes or mistakes were found.

5.4.1. Bare soil functioning

The different crop models were developed independently by several authors, so that small differences could be observed in the soil submodels. These differences had to be corrected to have the same results, whatever the model, in bare soil situations. The same input file without crop was used for every models in the project (maize, wheat, sugar beet, oilseed rape), and every difference in the soil transfers was corrected. The crop submodels had some small problems with water distribution and nitrogen uptake, so that budgets were not exactly correct. **All transfers and transformation were verified and corrected.**

Finally, before risk assessment, all models had exactly similar bare soil functioning and exact water and nitrogen budgets.

5.4.2. Input/output files

5.4.2.1. Parameters File (soil and techniques)

Another difference between the crop models was the input files. The same information is required but each author programmed a different format. All codes were modified to have systematically similar input files, except for one crop-specific line with genetic parameters. The example file on Figure 40 presents a parameter file for maize. Modification of line 3 is enough to simulate in the same conditions any other crop.

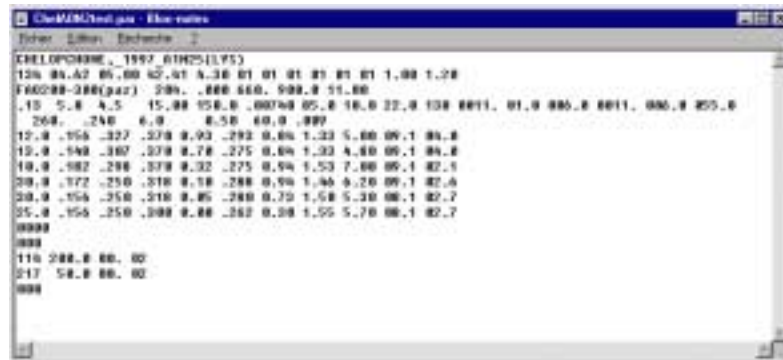

```

C:\MEM\test.pas - Bloc-notes
-----
CROUCHERNE_1997_0102011753
120 00.00 05.00 02.01 0.30 01 01 01 01 01 01 1.00 1.20
FACTOR-300(gaz) 300. .000 0.00 0.00 0.11.00
.10 5.0 4.5 15.00 050.0 .00700 05.0 10.0 22.0 100 0011. 01.0 000.0 0011. 000.0 055.0
200. 240 0.0 0.50 00.0 000
10.0 .950 .327 .270 0.93 .293 0.00 1.33 5.00 00.1 00.0
10.0 .940 .367 .270 0.70 .275 0.00 1.33 4.00 00.1 00.0
10.0 .902 .290 .270 0.32 .275 0.00 1.53 7.00 00.1 02.1
20.0 .972 .250 .210 0.10 .200 0.00 1.40 6.20 00.1 02.0
20.0 .950 .250 .210 0.05 .200 0.70 1.50 5.30 00.1 02.7
25.0 .950 .250 .200 0.00 .202 0.30 1.55 5.70 00.1 02.7
0000
110 000.0 00. 00
217 50.0 00. 00
0000
  
```

Figure 40: Common structure of parameters files, whatever the crop

5.4.2.2. Meteo file

There were also small differences in the meteo formats that were corrected. All models now use the same kind of meteo files. Concerning the risk assessment, giving fixed dates for irrigation is not acceptable, because rainfall might occur precisely on that day, provoking drainage and leaching that would not occur in real life. An option controlled by a switch in the parameter file can activate an automatic irrigation controlled by extractable soil water. The user defines a threshold and a quantity of irrigation, and each time the simulated Potentially Extractable Soil Water decreases below that threshold, irrigation is applied. An additional output file is generated to observe the irrigation applied (Figure 41).

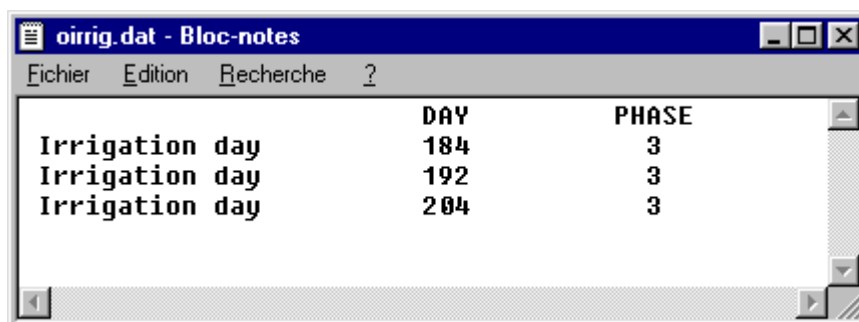

```

oirrig.dat - Bloc-notes
-----
Fichier Edition Recherche ?
Irrigation day      DAY      PHASE
Irrigation day      184      3
Irrigation day      192      3
Irrigation day      204      3
  
```

Figure 41: Output control of auto-irrigation

5.4.2.3. NCSOIL File

The NCSoil subroutine considered the two first layers identical. An error was generated if the second layer had a different density (or thickness) from that of the first layer. That error has been corrected in all models.

More generally, the structure of NCSoil is completely different from other subroutines, and principally it does not keep the variable names, that makes difficult understanding and eventual corrections. An effort could be made in that correction. The general feeling of many

users is that NCSoil has a much higher level of complexity than the rest of the model, that makes it hard to understand, control and parameterise.

5.4.3. Management of different crop models

Simulating different crop models requires from one hand differences in the parameter files and from the other hand differences in the codes themselves. A very short description of these differences is proposed below, but users must refer to the models documentation or to the authors for comprehensive descriptions of the plant specificities.

5.4.3.1. Plant parameters

All plant-related information are gathered in only one line of the parameter file (line 3) in order to make as easy as possible the change of the simulated crop in the same field conditions. Three strategies are used.

For maize and sugar beet, all parameters are present in line 3 of the parameter file; this is easy to change but you cannot keep the characteristics of one cultivar to use it later, you would have to change the parameters back to their previous values.

For wheat, only the cultivar name is present in line 3 of the parameter file, then a file containing all the cultivars characteristics is browsed by the code to find the one read in the parameter file. Therefore you can change the cultivar only by changing the name in the parameter file.

For rapeseed, too many parameters are required to be listed in the parameter file. Line 3 is not read, and the parameters are in files present in the working directory.

5.4.3.2. Main differences between the codes

The main differences are in phenological stages, which themselves drive the whole development of the crops. The numbers of stages vary, as well as their durations and impacts on physical transfers (water and nutrient uptakes). For instance, sugar beet development is divided into two stages (sowing to emergence and emergence to technical maturity), when other crops have five to seven stages, like mid-flowering, flowering, beginning of grain filling, and maturity for rapeseed. Refer to the models documentations or to the authors for comprehensive descriptions of the plant specificities.

5.4.4. Limits

The models have still to be improved, and during the project we have listed some priorities concerning future points demanding further attention.

5.4.4.1. Number of layers and depths

The good functioning of water transfers with the reservoirs hypothesis requires that successive layers have the same thickness. A smaller layer limits water infiltration with no physical justification. Consequently, even when a precise soil description is available with different layers of different textures, approximations must be made to have layers of equal thickness. An improvement of the model could be to check if the layers have equals thickness, and if not, to warn the user or build an appropriate simulation profile.

5.4.4.2. Heavy rain events

After a large amount of rainfall or irrigation, the model keeps the water that could not be transferred in the profile in the surface layer. That results in water contents in surface layer that can exceed saturation and even 1. This is physically nonsense, or can be considered as a layer of water waiting to be transferred in the soil. As a result this amount of water is available in the model much longer than in reality. That could be corrected with:

- Runoff
- Preferential flow
- Repartition of the water in excess in lower layers

No easy efficient solution was found up to now, and these three processes should be envisaged together.

5.4.4.3. High ammonium content soils

With certain kinds of soil characterised by high ammonium contents, the nitrogen chemical transformations subroutine overestimates the nitrification process and converts quickly all ammonium in nitrate, increasing nitrate leaching and nitrate availability in proportions not observed in field. Such conditions are quite exceptional, and measurements are in progress to check if the ammonium contents are really so high in these fields or if the measurements methods differ.

5.4.4.4. Root water uptake function

We have observed different functions of root water uptake in the different crop subroutines, with sometimes problems of water depletion in some layers. These functions are empirical and should be controlled by parameters defined by the user in the parameter file. However for some crops these factors have no influence. Further research should be done on that critical topic controlling altogether water content and water (and therefore nutrients) uptake.

5.4.4.5. Cold

We have observed in the fortran codes different functions of effect of cold temperatures that cannot be parameterised by the user. These functions were developed for North America weather conditions and cultivars, and are not suited to European conditions. In our simulations we experienced severe effects on number of plants mainly, that were not observed in the field, with climatic events that had nothing exceptional for the regions considered. Such functions should be controlled by parameters defined by the user.

5.5. Conclusion

We have now a coherent series of models calibrated and validated on site for the three crops considered in this project and a crop used for intercropping. Of course several limits remain but improvements are in progress. Furthermore other crops might be added soon (sorghum, barley), that would allow the possibility to assess many crop rotations.

Substantial efforts were done in INRA-Grignon to make the model coherent and user-friendly. These efforts are reward by solicitations from many users outside this COPERNICUS project for the models and tools.

6. Calibration of experimental conditions

6.1. *Bojurishte (Wheat)*

6.1.1. Experiment description

Bojurishte experimental station is situated on leached chernozem-smolnitsa (Vertisols). Historical data about soil (moisture, N-NO₃ and N-NH₄-content evolution) and crop (development and dry matter allocated to different wheat organs) are available (Radenkova-Karaivanova, 1964; Dinchev & Badjov, 1973). Soil hydraulic properties (including pF-curves measured under laboratory conditions) are well specified (Doneva, 1976).

Mineral nitrogen fertilisers in use in Bulgaria are: Ammonium nitrate, Triple Superphosphate and Granulated Superphosphate. Application rate depends upon the soil and its N-content, cultivated crops and expected yield, management operations and water application. Application rates for wheat ranges from 120 to 180 kg/ha. It is split in two: half before sowing and the rest in early spring.

6.1.2. Measurements

Soil samples to determine background nitrogen and soil water content were taken at the depth 5, 20, 40, 60, 80 and 100 cm prior to sowing. Additional soil samples to evaluate soil moisture evolution for each treatment were taken every month after snow melt. N-content of the soil was assessed at tillering, flowering, milky ripening and final harvest. Soil samples were analyzed for N-NO₃ and N-NH₄. Mineral nitrogen is extracted by 2M KCl. Organic carbon content of the soil was determined from initial soil samples using the methodology of Kononova (1963).

Plants were partitioned into leaf, stem and spike. Leaf area was determined manually by measuring leaf's width and length. All samples were dried at least 72h at 65°C before determining the dry matter weight. Nitrogen was determined for all samples by Kjeldal digests (Persson, 1996). Phenological development was recorded when 50% of the plants had reached a particular stage.

6.1.3. Treatments and replicates

Experiments were performed with and without irrigation. Two levels of fertilisation were used: 0 and 200 kg N/ha. Three subplots were randomly selected for destructive sampling for each treatment. Wheat was sown in October/November at a target population 600 plants m⁻². Plots of the treatments N200 received half of their total N-dose as a basal fertiliser dressing just before sowing. Nitrogen fertiliser was broadcast manually. Second half was given in spring after snow melting i.e. in April. Regular winter and spring precipitation kept soil moisture of the root zone above or around FC under entirely dryland conditions until mid July.

6.1.4. Results synthesis

Above ground dry matter differs among nitrogen treatments. Final values ranged for non-fertilised treatments from 825 in 1997 to 1159 g DM/m² in 1998 and from 1426 in 1997 to 1881 g DM/m² in 1998 for the fertilised ones. Grain dry matter varied respectively from 445 in 1997 to 840 g DM/m² in 1998 for 0-nitrogen supply and from 827 in 1997 to 1155 g DM/m² in 1998 for the treatment "N200".

Variation in concentrations in soil of N-NO₃ and N-NH₄ across the experimental site affected plant growth, nitrogen uptake and possibilities for N-leaching for each treatment. After fertiliser application, N-NO₃ and N-NH₄ content of the top 20 cm-layer increased. The N-NO₃ peak moved down the soil profile later (see profile for 07.05.1998 in Figure 42) and it was then susceptible to leaching below the root zone. Soil samples from treatment N200 during both experimental years indicated that a significant part of N-NO₃ was extracted by plants or leached to a depth of 1.00 m during flowering (see profile for 09.06.1998 in Figure 42). The nitrogen content increased after harvest due to the remaining residues (see profile for 20.08.1998).

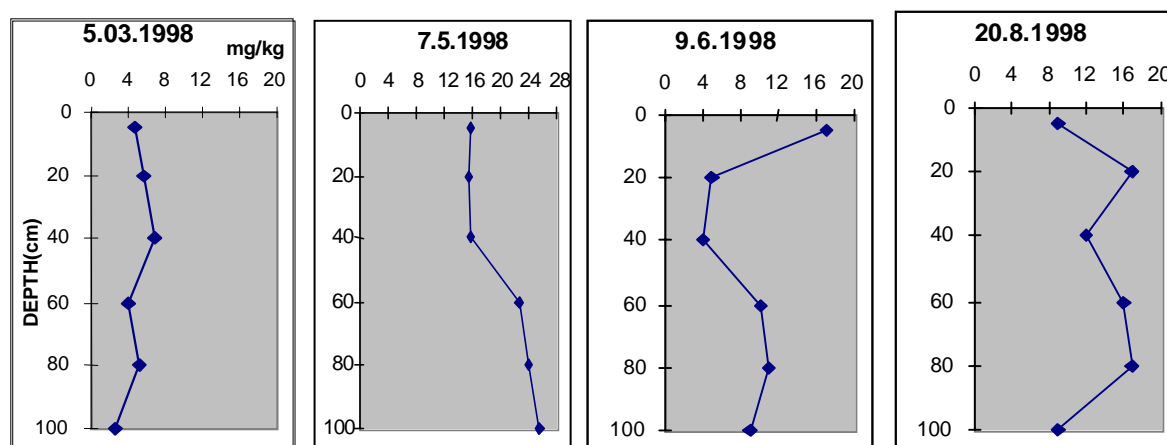

Figure 42: Some profiles of evolution of N-NO₃ in mg/kg soil for 200 kg/ha of nitrogen supply, Bojurishte 1998

6.1.5. CERES model calibration

According to the technical description of the project and the requirements of the CERES-wheat modified model, following input was provided for model calibration: soil water transfer characteristics for two layers, site specific and field management operation for the different treatments and soil layers information. Genetical inputs, corresponding to the cultivated wheat variety, were specified. Most of soil water input variables (soil albedo, drainage coefficient, and runoff curve number) were selected by analogy and estimated from CERES-wheat manual. Initial content of water and N-NO₃ in the soil corresponded to the respective measurements at the beginning of the simulations.

First calibration of soil water contents at saturation (SAT), drainage upper limit (DUL), lower limit (LL), bulk density and hydraulic parameters was based on references (Doneva, 1976). Water flow submodel in modified CERES-wheat uses the following equations:

WCC (water conductivity curve): $K(\theta) = K_{sat} \cdot \exp A(\theta - \theta_{sat})$ (Davidson *et al.*, 1969)

and WRC (water retention curve): $\psi(\theta) = \exp \sqrt{\frac{\theta_{sat}}{\lambda} \ln \frac{\theta}{\theta_{sat}}}$ (Driessen, 1986):

where A , λ and θ_{sat} are CERES-model input parameters.

Laboratory WRC data-points (Doneva, 1976) and references were used to specify γ and θ_{sat} for A-horizon (Figure 43) and B-horizon. Vereecken pedotransfer functions (Vereecken *et al.*, 1989), that transfer soil texture (particularly clay content) and bulk density of soil into WRC parameters, resulted in the dashed line. Fitted WRC-Driessen to the series of laboratory measurements (presented with the full line in Figure 43) was close to the calculated WRC-Vereecken (dashed one).

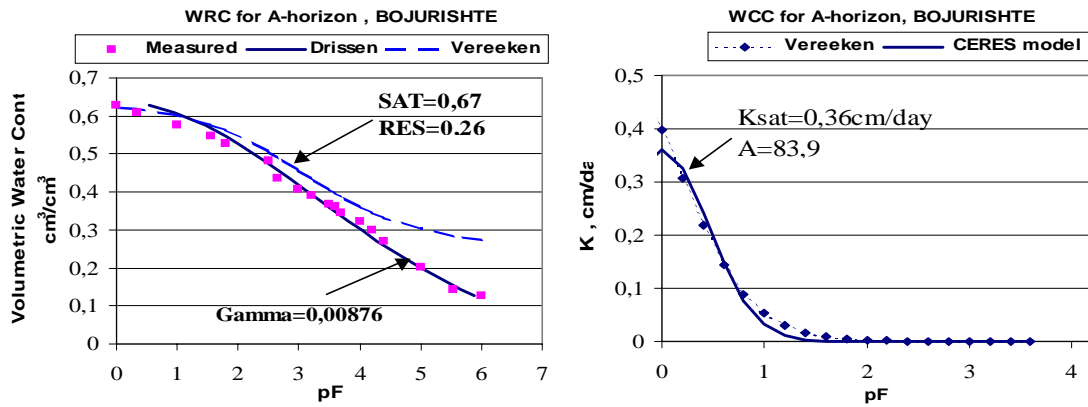

Figure 43: Calibration of WRC/WCC parameters on the basis of laboratory measurements

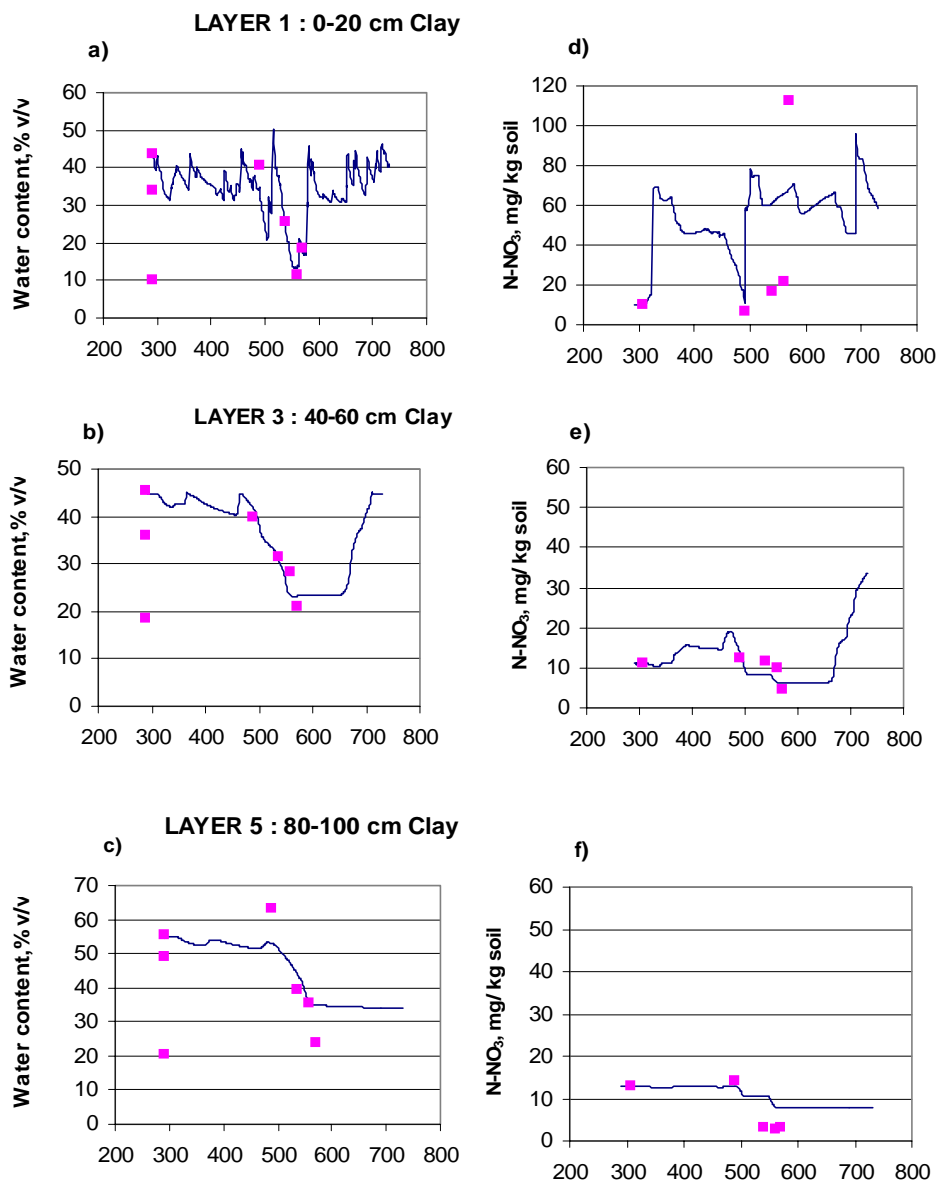

Figure 44: Measured and simulated Water and Nitrate contents of three out of five layers for “N200” treatment in Bojurishte, 1997. Black lines are simulations, squares are measurements. For water contents, the three points at the beginning represent, from bottom to up, wilting point, field capacity and saturation.

WCC relates water content to water transport and fluxes. WCC-Driessen (full line in Figure 43) was specified on the basis of laboratory and field measurements of saturated conductivity- K_{sat} and A- parameter fit to calculated WCC-Gardner on the basis of soil texture (Vereecken, 1988).

Modified CERES-wheat first test was not satisfactory for dryland plots due to a lack of a complete fit between simulated and calculated potentially extractable soil water (PESW) and water content (WC) at the bottom layer. Field measurements of the lowest WC (practically at LL) and at DUL were applied to adjust WRC-Driessen since using only laboratory moisture release data (Figure 43) might be a possible danger for model calibration. Laboratory WRCs proved to overestimate water content by about $0.15 \text{ cm}^3/\text{cm}^3$ in Vertisols. That is why in final parameter file γ -slope parameter was kept to the laboratory-based value (for instance $\gamma=0.00876$ for A-horizon) and SAT, DUL and LL values were adjusted to field measurements (that was $\theta_{sat} = 0.435 \text{ cm}^3/\text{cm}^3$, $\theta_{DUL} = 0.34 \text{ cm}^3/\text{cm}^3$ and $\theta_{ll} = 0.186 \text{ cm}^3/\text{cm}^3$). Parameters adjusted to field WRCs were used for the second model run. Figure 44a, b, c illustrates the final calibration test of simulated water content evolution over the specified three genetic soil layers for the fertilised treatment. One-to-one comparison of simulated with measured time series of water content and PESW for the plots in 1997 proved that, after the modification of the water retention of the soil profile, the model predictions were close to the experimental data. Coefficient of determination for soil moisture was $r^2=0.59$ for the non-fertilized treatment and $r^2=0.86$ for the fertilized one (Figure 45). Its respective values for PESW were $r^2=0.77$ for "N-0" level and $r^2=0.95$ for "N-200" one (Figure 45).

Figure 44d, e and f illustrate monitored and calculated N- NO_3 concentrations in the same soil profile. Coefficient of determination for "one-to-one N- NO_3 content "was $r^2=0.49$ for the fertilised treatment. Other treatments' outputs have been tested in a similar way. It was concluded that simulations of water and N- NO_3 content evolution in the root zone were close to the empirically based data over the whole range of conditions. As a response to crop water uptake, simulated soil moisture decreased down to wilting point in the layers colonised by roots at harvest. The model reflected well the phenomenon of water extraction and retention all over the layers of the root zone. Downward transfer and crop uptake of nitrate were not perfectly simulated but Figure 44d shows the depletion simulation of layer 1 and Figure 44e and f the following presence of nitrate in layer 3.

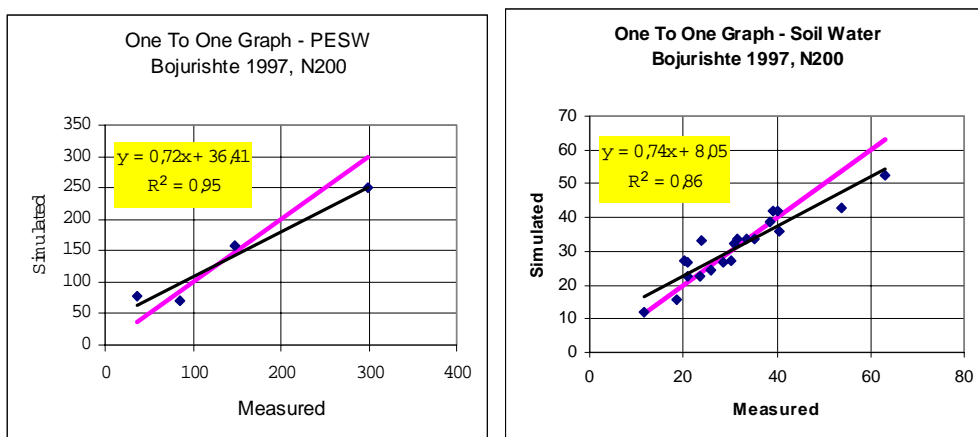

Figure 45: Simulated with measured time series of WC and PESW for the plots in Bojurishte for the experimental year of calibration

Calibration of the wheat phenological phases has been performed for the cultivated variety in Bojurishte. Parameters of the slope of the linear grain fill phase G2 and the length of photo-period P1v (CERES-Wheat documentation) have been adjusted to local conditions. That resulted in a reliable dry matter prediction of above ground plant/grain for fertilised (right graph in Figure 46) and non-fertilised treatment (left graph in Figure 46). Coefficient of N-stress for the non-fertilised treatment (given in Figure 46) proves that CERES-Wheat reflects crop response to insufficient nutrients in the root zone.

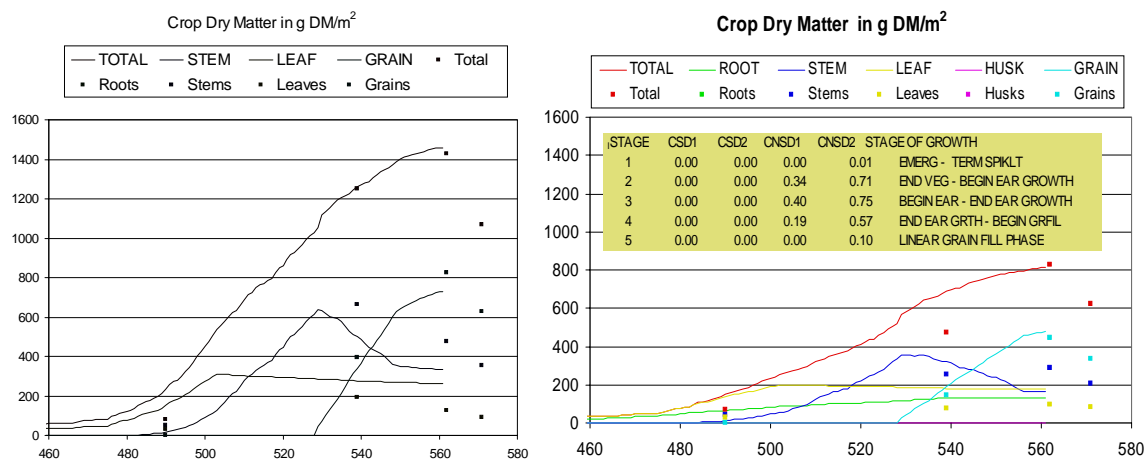

Figure 46: Comparison of model predictions for wheat dry matter with measured ones under fertilised and non-fertilised conditions

6.1.6. Model validation

Model validation was performed with data collected during the second experimental year (1998). Soil/plant parameters were kept to the values adjusted to the wheat field trials in 1997. CERES-Wheat outputs for 1998 are presented in Figure 47 and Figure 48. Figure 47a, b and c illustrates the final validation model test of simulated water content evolution over three specified genetic soil layers for the fertilised treatment in 1998. Figure 47d, e and f show monitored and calculated N-NO₃ concentrations in the same soil profile. It was concluded that simulations of water content evolution in the root zone were mostly close to the empirically based data. Model reflected well the phenomena of water extraction and retention over the root zone, except for surface layer, for fertilised conditions during validation. Results of soil nitrogen simulations are clearly less satisfactory. However it is undoubtedly due to measurements, the protocol of which could not be validated. We could not compare neither Romanian nor Bulgarian measurements to ours, and it is really a problem because with these data the nitrogen balance is wrong. Some measurements are evidences of unreliable experimental data, as for instance:

- in Figure 47d: no increase of soil mineral nitrogen in the first layer after a fertilisation,
- in Figure 47e: unexplained quick changes of soil mineral nitrogen in the 3rd layer only.

Besides, similar studies in France and other countries have shown a correct and coherent behaviour of soil mineral nitrogen simulations with CERES in various kinds of soils. Figure 48a showed the validation test of dry matter simulations for N200 level. Crop parameters choice for 1996/97 did not fit to the management conditions in 1997/98 when wheat was sown 29 days earlier. As a result the length of the first wheat development phase (look at the stepped line for stages scaled on a secondary axis in Figure 48) was shortened and total and grain dry matter were underestimated in validation model simulations. As soon as the length of first stage was secondary adjusted to the conditions of the validation experiments by

changing P1d parameter (a switch from vegetative to reproductive phase) from 1 to 5, the simulations of dry matter accumulation were improved (Figure 48b). So model needs some more adjustment in terms of plant development and water extraction/drainage simulations. It should be taken into account that in swelling soils, such as Vertisols, the water percolation could occur through the cracks in summer.

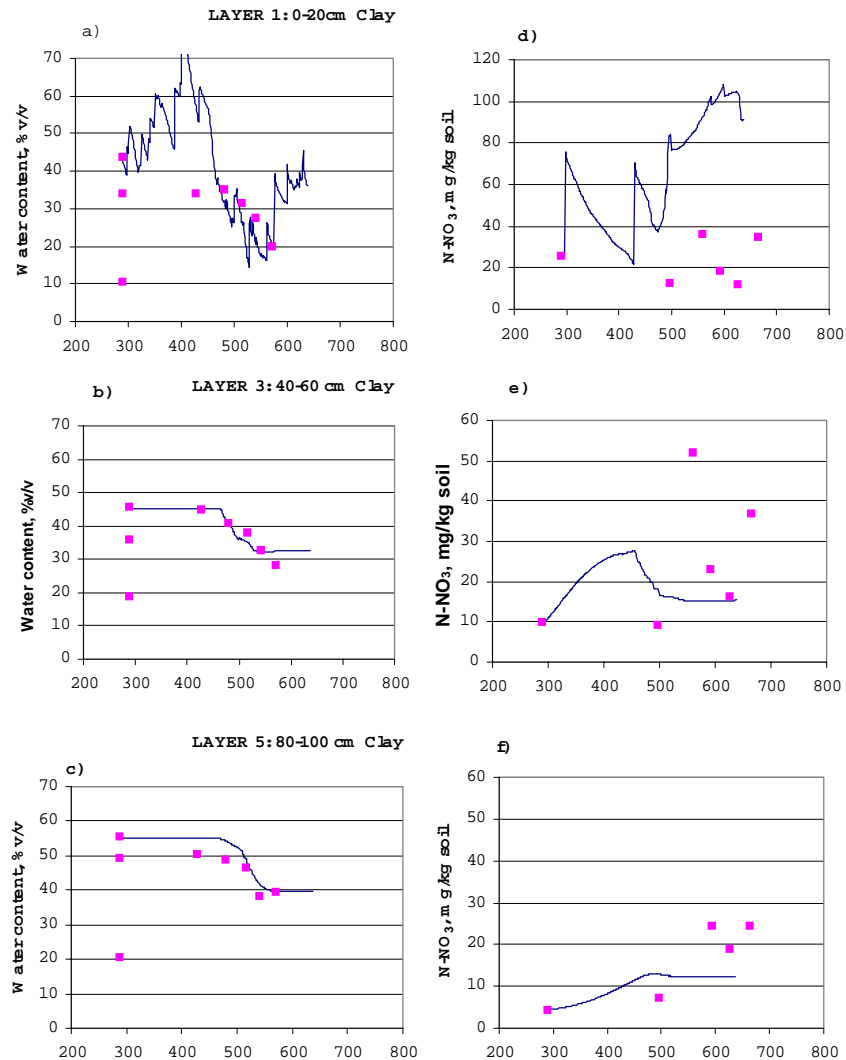

Figure 47: Measured and simulated water and nitrate contents of three layers for fertilised treatment Bojurishte, 1998. Black lines are simulations, squares are measurements. For water contents, the three points at the beginning represent, from bottom to up, wilting point, field capacity and saturation.

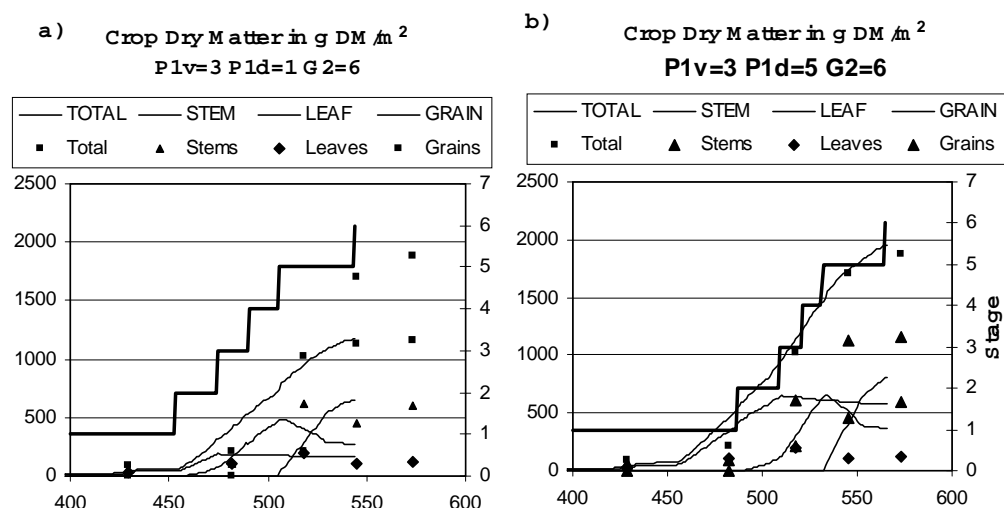

Figure 48: Model predictions for two sets of crop parameters and measurements of wheat dry matter for fertilised treatment in Bojurishte, 1998.

6.1.7. Utilisation for one crop and bare soil

Adjusted CERES-Wheat was run with three different N-application scenarios (N0, N200 and N150 level) under dryland and historical weather data. The rate of 150 kg/ha N were applied 1/3 before sowing and 2/3 after snow melting. Simulations were performed for seven representative years indicated in boxes in Figure 49. They correspond approximately to Probability of exceedance of precipitation $P=0$ (wet climate), 25 (moderately wet), 50 (medium), 75 (moderately dry) and 100% (dry). Simulated water and N-fluxes (below 1.00 m depth) have been used for risk assessment analysis over the whole studied period. The risk of groundwater pollution during a certain season was analysed over the complete cycle of vegetation (November-July) and the following post-vegetation periods (August-October). It was studied in terms of drainage and N-leaching below the root zone (1.00 m) over the period from November to July (Figure 49 and Figure 50 for vegetation) and from August to October (Figure 51 and Figure 52 for the fallow state of the field). The risk was related to the probability of exceedance of thirty-year series of annual precipitation sums. Extremes vegetation precipitation (1962/3 and 1976/7) did not change substantially total water drainage over years of contrastive precipitation sums (ranging from 229 to 749 mm) and different studied treatments (Figure 49). Deep percolation varied from 104 to 147 mm for vegetation that was 20-23% of total water supply. That was due to the extremely low permeability of the soil profile resulting in water preferential flow with heavy precipitation. N-leaching during vegetation depended to a certain extent upon the climate characteristics and rate of nitrogen application. It changed from 10 kg N/ha to 14.7 kg N/ha for "N0" level (diamonds), from 10.6 kg N/ha to 16.2 kg N/ha for the treatment "N150" (triangles) and from 10.9 kg N/ha to 16.2 kg N/ha for N200 (squares in Figure 50). The highest risk to groundwater occurred in the case of "wet wheat vegetation period" (1962/63) under fertilised conditions when 18 kg N/ha (10% of N applied) were flushed below the root zone over the complete cycle (Figure 50 and Figure 52). Thus maximum N-leaching under wheat cultivation presents approximately one third of the one under maize growth (1962/3) in Chelopechene site (moderately permeable Chromic Luvisol). The effect of the reduced N-supply before sowing was negligible in that case study.

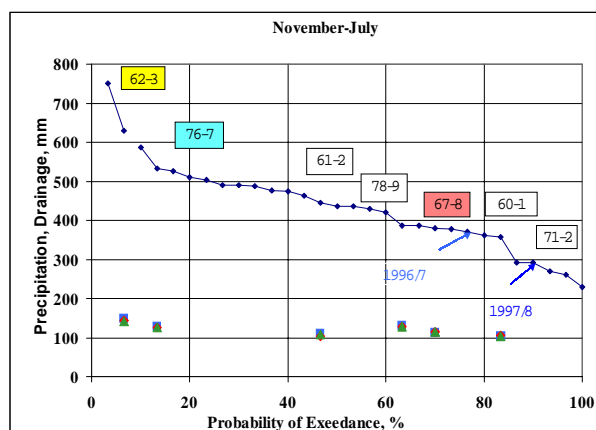

Figure 49. Drainage vs. P(%) for wheat vegetation

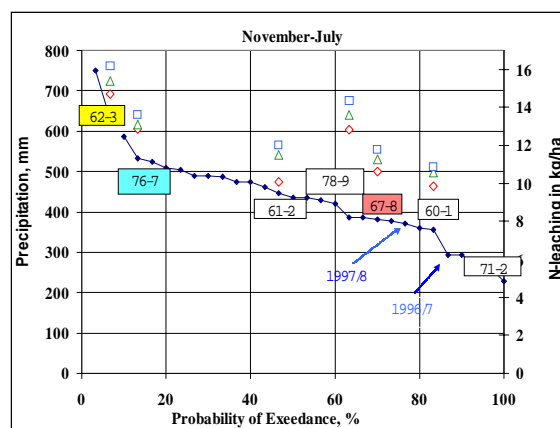

Figure 50. N-leaching vs. P(%) for wheat vegetation

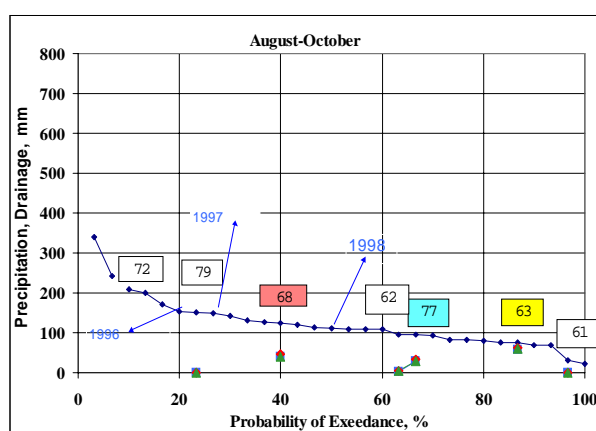

Figure 51. Drainage vs. P(%) for post-vegetation period

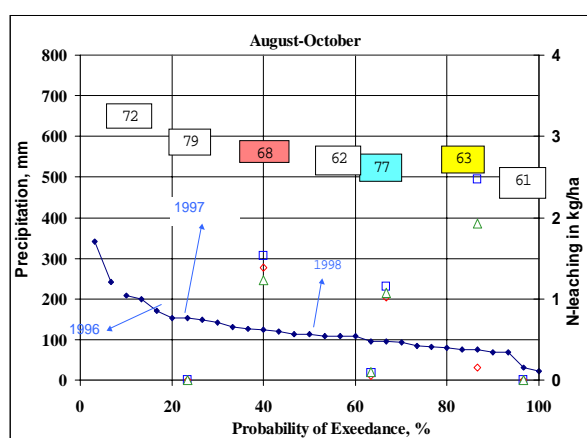

Figure 52. N-leaching vs. P(%) for post-vegetation period

Figure 49-Figure 52. Modelled Drainage (Figure 49 and Figure 50) and Nitrate leaching (Figure 51 and Figure 52) in relation to Probability of exceedance P(%) of rainfall totals P (1960-1990) for wheat vegetation period (November-July) and fallow state of the field (August-October). In the four figures, squares (■) represent the treatments "N200", triangles (▲) represent the treatments "N100" and the diamonds (◆) represent the treatments without fertilization. Open symbols are for nitrate leaching, closed ones for drainage. The simulated years are indicated in the boxes.

6.2. Chelopechene (Maize)

6.2.1. Experiment description

Chelopechene experimental station is situated on leached cinnamonic forest soil of loamy texture (Cl=43-24% Sa=33-63% Si=32-15%) and moderate saturation hydraulic conductivity (15-40cm/day). The area contributes to flow discharge into the Danube River watershed through a tributary (the Iskar River).

Mineral nitrogen fertilisers in use in Bulgaria are: Ammonium nitrate, Triple Superphosphate and Granulated Superphosphate. Application rate depends upon the soil and its N-content, cultivated crops and expected yield, management operations and water application. Application rates range from 120 to 180 kg N/ha. It is split in two or three with maize growing: half or one third before vegetation and the rest during crop development stage.

6.2.2. Measurements

Soil samples to determine background nitrogen and soil water content were taken at the depth 5, 25, 35, 65, 95 and 120 cm prior to sowing. Additional soil samples were taken every fortnight to evaluate soil moisture evolution for each treatment. Tensiometers in the lysimeter were installed and read every other day from June to November. Their calibration for the two representative soil layers was based on measured pressure head of the soil matrix and corresponding thermo-gravimetric soil water content. The volume of deep percolation drained at the bottom of the lysimeter was measured volumetrically. Crop water use is assessed in situ by application of water balance concept (Jensen, 1973). It is evaluated marginally in the plots (when "zero flux plain" is developed in periods of dry weather or small rainfalls) and all over vegetation in the lysimeters. N-content of the soil was assessed at flowering and final harvest too. Soil samples were analysed for N-NO₃ and N-NH₄. Mineral N is extracted by 2M KCl. Organic carbon content of the soil was determined from initial soil samples using the methodology of Kononova (1963).

Two subplots were randomly selected for destructive sampling for each treatment. Plants were partitioned into green leaf, eventually leaf sheet, dead leaves, stem, cob, and storage organs. Leaf area was determined manually by measuring leaf's width and length. All samples were dried at least 72 h at 65°C before determining the weight. Nitrogen was determined for all samples by Kjeldal digests (Persson, 1996). Phenological development was recorded when 50% of the plants had reached a particular stage.

Every day meteorological data (air temperature, precipitation, wind velocity, air humidity and global solar radiation) was provided by the MTO station of N. Poushkarov Institute for the experimental years. The published data of Sofia MTO station (Meteorological Annual References, 1960-1980) were used for a 20-year period.

6.2.3. Treatments and replicates

Field trials were carried out under full irrigation (A1) or entirely stored moisture (A0). Three level of nitrogen fertilisation (in kg N/ha) termed here as N0, N200 and N400 were applied to the maize crop. Each treatment was replicated triple and plot sizes were 11x9 m except for a lysimeter of size 2 m width x 10 m length x 3 m depth that served as forth replication of the treatment *AIN200*. Nitrogen fertiliser was broadcast manually. Rows had "South-east"- "North-west" orientation and row spacing was 0.70 m. Sub-plots for destructive harvesting measured two rows by 0.7 m (15.4 m²). Since enough rain fell before the beginning of the experiment the soil was wet up to 75% of field capacity to the maximum depth of observation 1.2 m at the moment of sowing. Maize was sown at the end of April at a target population 6-7 plants m⁻². Plots of the treatments N200 and N400 received half of their total N-dose as a basal fertiliser dressing just before sowing. Nitrogen fertiliser was broadcast manually. The second half was given during vegetation. Due to the regular rain fell in June and July in 1997 and 1998 root zone, soil moisture was kept above 75% of field capacity under entirely stored moisture. Irrigated plots were watered (45-85 mm) in the second half of July (after the second nitrogen application) and August.

6.2.4. Results synthesis

Above ground dry matter (DM) differs among water and nitrogen treatments. Final values ranged from 600 to 1800 g/m² for dry land and 1420 to 2100 g/m² for optimum water. Because of comparatively rainy July during experimental years, LAI reached its maximum value of 2.2-3.5 at all plots in the beginning of flowering stage. It drastically dropped in the beginning of August at treatments under entirely stored soil moisture and nitrogen. Crop

water use (ET) reached its maximum in the middle of July (silking of maize) for all treatments. Due to the drought in August, ET drastically dropped then for all treatments under entirely stored soil moisture. Cumulative ET did not range significantly over different levels of N-supply for dry land (in particular from 342 to 348 mm from 29.05. till 22.10.98) that was in an agreement with the results about harvested yield. Supplementary water supply in the second half of July and August resulted in ranging crop water use over different N-levels. Cumulative water use for the same period in 1998 varied from 379 mm for non-fertilised treatment to 523 mm for the fertilisation rate of 400 kg N/ha.

N-NO₃ and N-NH₄ concentrations in soil varied across the experimental site and affected plant growth, nitrogen uptake and leaching below the root zone. N-NO₃ and N-NH₄ content of the top loam-layer increased immediately after fertiliser application (Figure 53-11.06.97.). Soil samples indicated that Nitrogen was not extracted completely to a depth.1.20 m in the dry treatment A0N200 (Figure 53 - 17.10.97.) and A0N400. It was used or flushed below under irrigation treatment A1N20 (Figure 53 - 17.10.97) and A1N400.

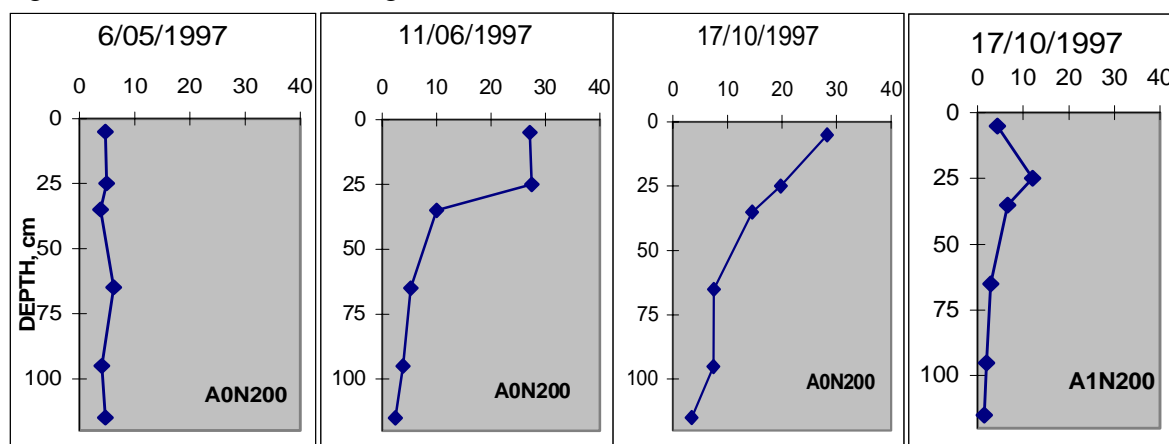

Figure 53: Some profiles of evolution of N-NO₃ in mg/kg soil at dry and irrigated treatment for 200 kg/ha of nitrogen supply

Over all treatments nitrogen uptake and contents in aboveground plant components followed the same seasonal evolution character as illustrated in Figure 54 for A1N200 treatment. Total aboveground plant and kernel nitrogen continued to increase until waxy ripening phase nevertheless that N-concentrations in leaves and stems reached their minimum values then. At harvest more than ¾ of total extracted N was hold in the storage organs that was the case with all treatments. Results about N-uptake in the aboveground plant and grain were compared for different level of N-application under irrigation and dry land conditions (as shown for full water supply in Figure 55). They showed quantitative differences dependent on the water and nitrogen supply and their interactions. N-content of shoot in dry land was 8.6 g/m² at N0, 14.6 g/m² at N200 and 13.6 g/m² at N400-treatment while kernel nitrogen there varied from 6.5 at N0 to 10.0 and 9.2 g/m² respectively at N200 and N400-level at waxy ripening. Aboveground plant and grain N-uptake were more efficient under sufficient water supply: former reached 19.1 g/m² at N200 and 16.8 g/m² at N400 (Figure 55) while latter were 13.0 g/m² at N200 and 14.3 g/m² at N400-level at waxy ripening.

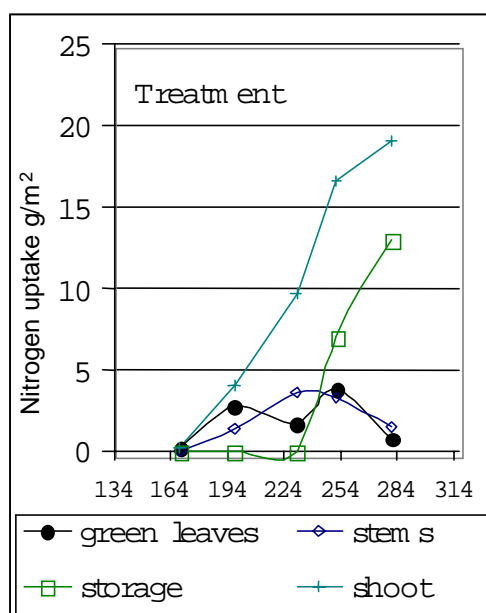

Figure 54: N-content of plant components over DOY (Day of the year) for the optimal treatment in Chelophechene, 1997

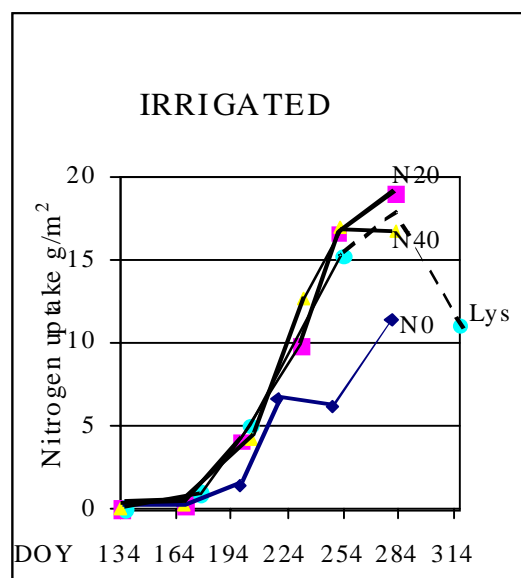

Figure 55: Comparison of total N-uptake for the irrigated treatments in Chelophechene, 1997

There were no significant difference in the yield and N-uptake at fertilisation of 200 and 400 kg N/ha under irrigation conditions for a particular climatic year. Figure 55 illustrates that potential plant N-extraction was 146 kg N/ha at dry land and 191 kg N/ha at irrigated plots.

Leached N for the level N250 monitored below the bottom of the lysimeter was 17 kg N/ha from May 1997 to June 1998 (Table 5). Risk to environment would increase when mineral nitrogen is not used by plants and leached below the root zone with precipitation and irrigation. It is a variable that was studied in long term by model simulations. Results are presented in the part consecrated to risk assessment for ground water pollution.

N-application rate kg/ha	Period	Precipitation + irrigation mm	Drainage at 2 m depth mm	Leached N-NO ₃ below 2m kg/ha
250	05.-09.97	256+133	45.5	12.1
	09.97-06.98	328	25	4.9
300	06.-10.98	232+315	54.5	11.1

Table 5: Deep percolation and N-NO₃ load at the two-meter depth

6.2.5. CERES model calibration

CERES-maize model (Jones & Kiniry, 1986; Gabrielle *et al.*, 1995; Gabrielle & Kengni, 1996) has been extensively calibrated on the grounds of the lysimeter trial in 1997 that provided data for content of water, N-NO₃ and N-NH₄ of soil, soil matrix potential, evapotranspiration, water and N-fluxes at two-meter depth. The following input was provided for model calibration: soil water input, site specific and field management operation for the different treatments, genetical input and soil layer information.

Most of soil water input variables (soil albedo, drainage coefficient, runoff curve number) were selected by analogy and estimated from CERES manual. First calibration of soil water contents at saturation (SAT), drained upper limit (DUL) and lower limit (LL), bulk density (BDM) was based on references (Mehandjieva, 1974). Initial content of water, N-NO₃ and N-NH₄ in the soil corresponded to the respective measurements. CERES test was satisfactory for rainfed plots with that run. That was not the case with the treatments under full water supply due to a lack of fit between simulated and calculated potentially extractable soil water (PESW) and water content (WC) at the least permeable clay layer after irrigation. Detailed calibration/validation of CERES in terms of simulation of WC and PESW was carried out for lysimeters. Hydraulic parameters of the soil were adjusted to field evaluation of water retention curve-WRC, water conductivity at saturation Ksat and measured fluxes there. Modified CERES-model accepts that water flow within/below the root zone is controlled by the least permeable soil layer of the profile.

Historically and newly obtained (in field and in laboratories) hydraulic properties data and references were used to specify γ and θ_{sat} soil parameters of WRC - Driessen (Figure 56). Vereecken pedotransfer functions (Vereecken *et al.*, 1988), that transfer soil texture (particularly clay content) and bulk density of soil to parameters WRC-Vereecken, resulted in the full line in Figure 56a. Calculated water content at saturation was respectively $\theta_{sat}=0.437 \text{ cm}^3/\text{cm}^3$. Fitting WRC - Drissen to the series of laboratory measurements was presented with the dotted line in Figure 56a. γ -parameter was estimated to $\gamma=0.0074$. The agreement between laboratory based data, calculated θ_{sat} , WRC-Vereecken (Vereecken *et al.*, 1989) and derived WRC -Drissen equation was satisfactory (Figure 56a).

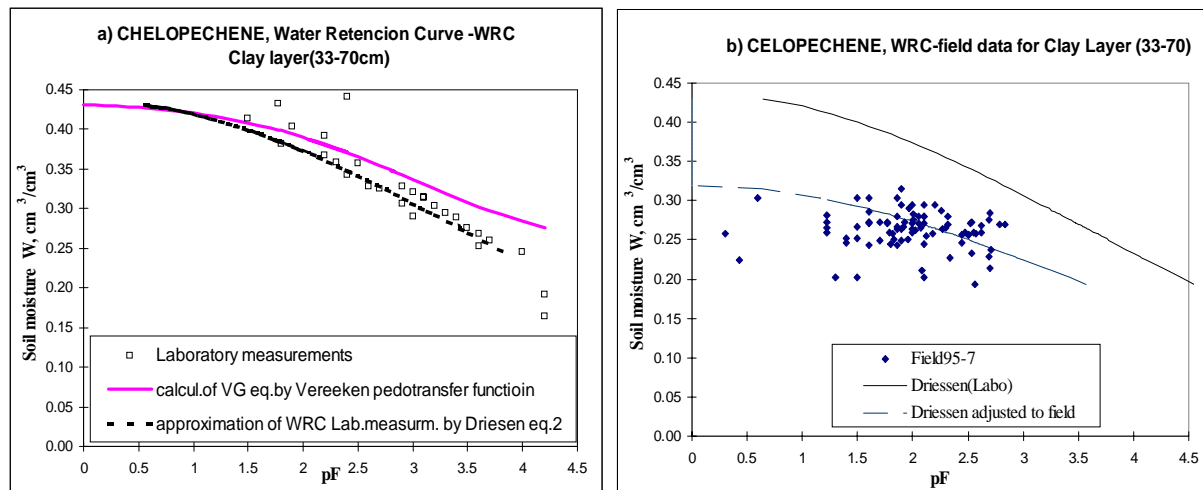

Figure 56: Adjustment of laboratory WRC to field measurements

Field measurements of water retention during three experimental seasons (95, 96 and 97) were shown in Figure 56b. Hydraulic pressure head, obtained *in situ* by tensiometer readings, was related to corresponding volumetric water content evaluated by soil sampling. *In situ* WR-data points were obviously situated lower compared with the full line of laboratory WRC for $\psi(\theta)$. Figure 56b pointed out also that field data scatter significantly due to hysteresis or experimental errors. On the other hand using laboratory moisture release data (Figure 56a) might be a possible danger for model calibration. Laboratory measurements overestimate

water content by $0.5-0.15 \text{ cm}^3/\text{cm}^3$ and they are usually accepted reliable when slope parameter is yielded and biased for θ_{sat} (Diels, 1994). That is why statistical analysis of field WR data was performed when γ -slope parameter was kept to the laboratory-based value ($\gamma=0.0074$) and θ_{sat} value was adjusted to field data points (the dashed line in Figure 56b). The latter resulted in $\theta_{\text{sat}}=0.318 \text{ cm}^3/\text{cm}^3$ and water content at field capacity $\theta_{\text{FC}}=0.25 \text{ cm}^3/\text{cm}^3$ (corresponding to $pF=2.5$ value of field WRC).

WCC relates water content to water transport and fluxes. WCC ($K(\theta)$) was specified on the basis of laboratory and field measurements of saturated conductivity- K_{sat} . K_{sat} values was derived from 7-8 replicates for each soil layer in laboratory and compared with *Field* K_{sat} , measured by saturation of the lysimeters. The parameter A was fitted to Gardner WCC calculated on the basis of soil texture (Vereecken, 1988). Comparison of simulated with measured time series of PESW for the lysimeters has proved that, after the modification of the water retention of the soil profile, irrigation water drains in simulation in a much similar way to the real world.

CERES-maize model has been tested primarily to local conditions by comparison of measured data (content of water, N-NH_4 and N-NO_3 of soil, evapotranspiration, water and N-fluxes) with model outputs. Figure 57a, b c present the comparison of simulated and measured time-series of volumetric water contents for three genetic soil layers of the treatment at the level N250 (250 kg N/ha) in the lysimeters in 1997. The horizontal lines emphasise the water content at saturation and field capacity. Next to them Figure 57d, e and f illustrate monitored and calculated N-NO_3 concentrations in the same soil profile. It is concluded that simulations of water and N-NO_3 content evolution in the root zone were close to the empirically based data over the whole calibration trial. As a response to crop water uptake, simulated soil moisture decreases down to wilting point in the layers colonised by roots. In the surface layer, evaporation extracts water even below that threshold (Figure 57a).

Figure 58 compares simulated with measured crop water use in cumulative terms. Plant water uptake was satisfactorily simulated and seasonal overestimation of 10 mm (5.8% of the total for the period) was acceptable. The model reflects well the phenomenon of water extraction and retention all over the layers of the root zone. Figure 59 is related to cumulative depth percolation at the bottom of the lysimeter for 1997. On the second axe of Figure 59 precipitation and irrigation over the period were scaled. It should be noticed that CERES-maize did not take into account the preferential fluxes occurring after big water application (60 mm/day, that was the case in Day Of the Year (DOY) 198 and DOY 224 (Figure 59). Finger-type infiltration, that resulted in the mounting steps in the measured drainage, was smoothed in simulations and as a result simulated cumulative flux at 2m depth was underestimated.

Downward transfer and crop uptake of nitrate were clearly correctly simulated too, as shows the depletion of layer 1 (Figure 57d) and the following presence of nitrate in layer 3 (Figure 57e).

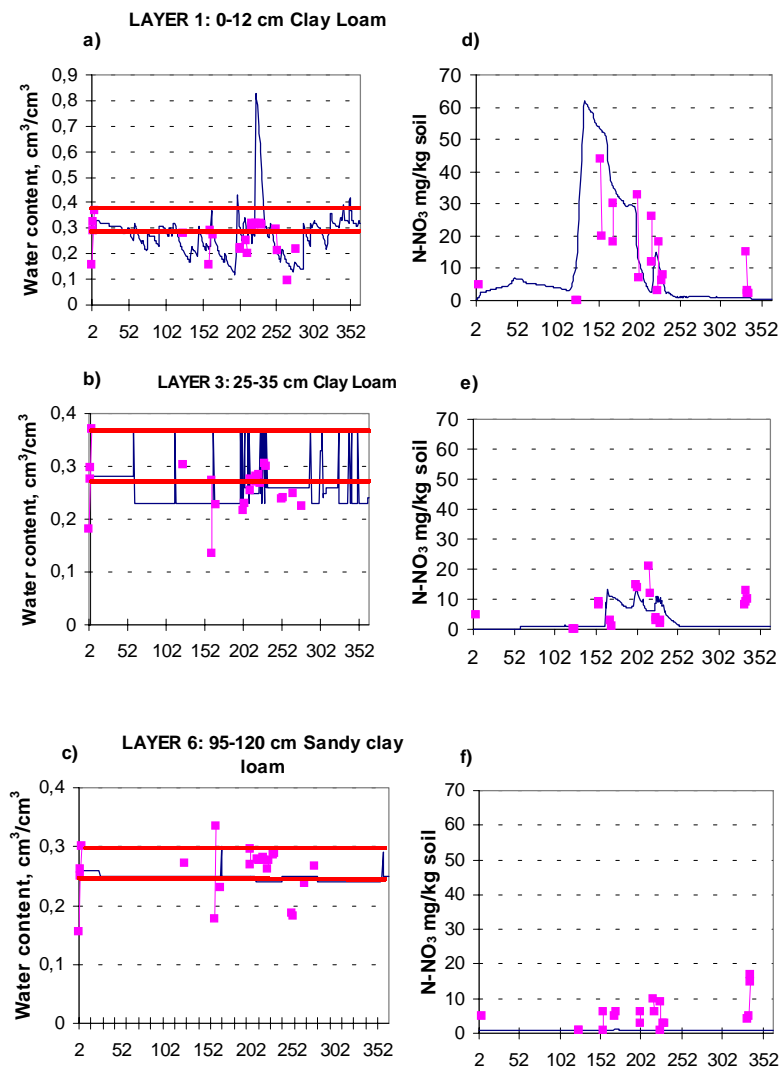

Figure 57: Measured and simulated Water and Nitrate contents of three layers in lysimeters, Chelophechene, 1997. Black lines are simulations, squares are measurements (replicates if linked). For water contents, the four points at the beginning represent, from bottom to up, wilting point, field capacity, initial value and saturation.

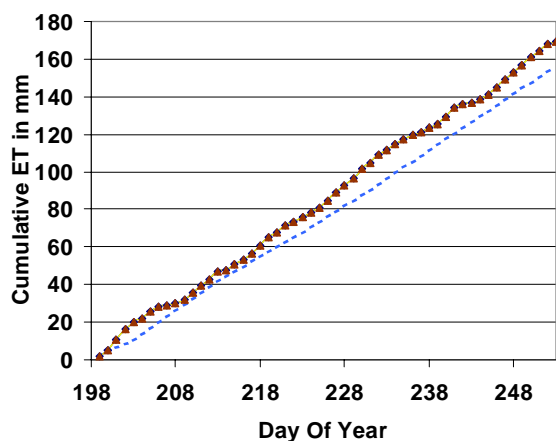

Figure 58: Simulated (triangles) and measured (interrupted line) EvapoTranspiration with optimum irrigation and fertilisation, Chelophechene, Lysimeter, 1997

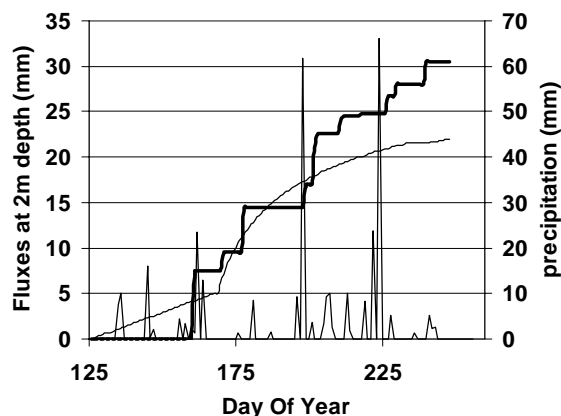

Figure 59: Simulated (narrow line) and measured (broad line) cumulative drainage, and daily precipitation+irrigation, Chelophechene, Lysimeter, 1997

6.2.6. Model validation

In situ model validation has been performed on the grounds of the crop/soil/management data collected in field plots in 1997. Parameters, adjusted by means of the calibration lysimeter trial, were tested with simulations for irrigated/dryland plots at nitrogen level of N200. First model validation was made in terms of simulated/measured Potentially Extractable Soil Water (PESW-CERES output), defined as the difference between the water storage in the root zone at wilting point and the actual one. It was proved that adjusted CERES-maize simulates satisfactory integral water retention and extraction for the total root zone under dryland and irrigated field conditions. Afterwards validation passes through the specifics of the different soil layers. Figure 60a, b and c compared monitored and calculated volumetric water contents for three genetic soil layers of the irrigated treatment at the level of N200. Horizontal straight lines represent water content at saturation and field capacity while the square at the bottom of y-axis signifies the water content at wilting point. Monitored and calculated N-NO₃ concentration in the same profile were presented next in Figure 60d, e and f.

Figure 61 illustrates similar CERES-maize model validation for the plots under entirely stored soil moisture at the level of N200.

Performed validation test of water content and PESW prediction across a wide range of water conditions (Figure 60 and Figure 61) proved that simulation of these variables had been improved when compared with preliminary model test before detailed calibration with lysimeter data. As a response to different water supply and crop water uptake soil moisture decreased down to wilting point in the layer 3 incidentally (Figure 60b) or constantly (Figure 61b). Irrigation water supply led to constant maintenance of water content near field capacity at the bottom layer (Figure 60c). It was not the case with dryland (Figure 61c). Downward transfer and crop uptake of nitrate was more intensive under irrigation conditions (Figure 60a). In the final analysis it was concluded that model mimics well the phenomena of extraction, retention and transport of water over the layers under different water supply. Simulations of the N-NO₃ content were also close to the observed data over the range of conditions of validation.

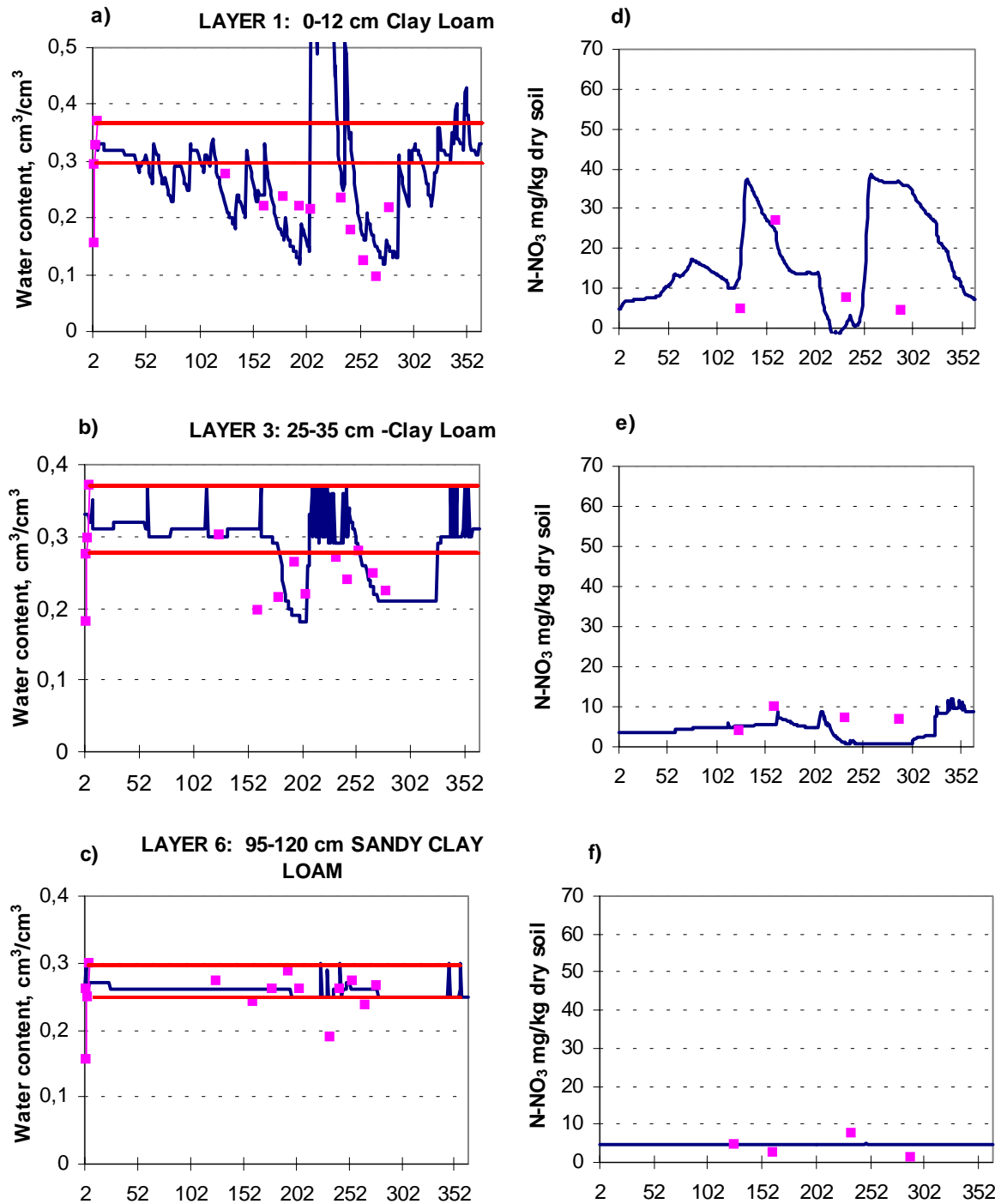

Figure 60: Measured and simulated water and nitrate content for three layers in irrigated field plots, Chelophechene, 1997.

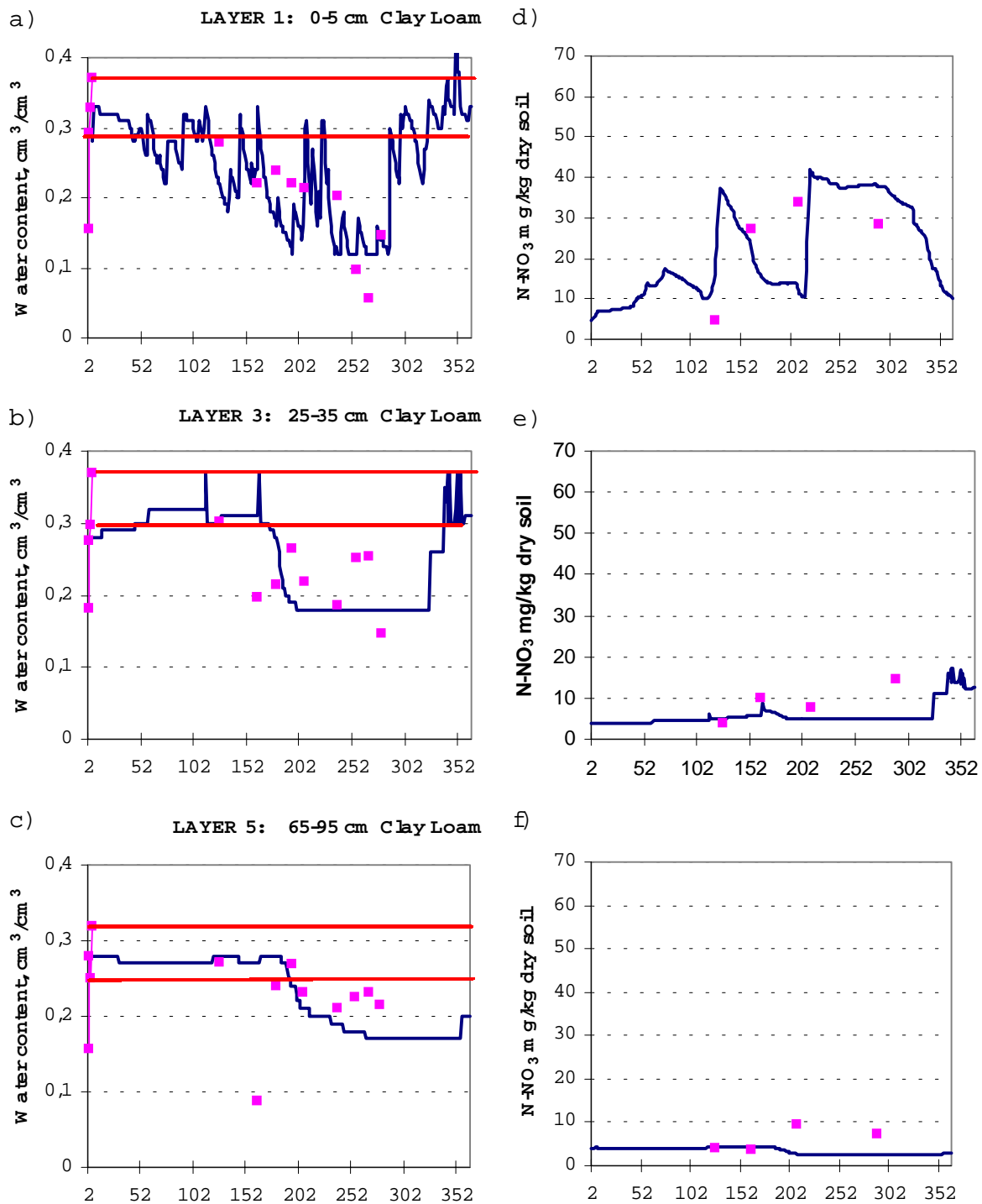

Figure 61: Measured and simulated water and nitrate contents of three layers for dryland plots in Chelophechene, 1997.

6.2.7. Utilisation for one crop and bare soil

The adjusted version of CERES-maize was run with different water application scenarios and historical weather data (Popova *et al.*, 1999). The CROPWAT program (Smith, 1992) was applied to determining the optimal and environmentally oriented irrigation schedule of maize. Long-term potential evapotranspiration (Raes *et al.*, 1986) has been derived out of daily climatic data for Sofia (Meteorological annual references). Sowing date and phenological phases duration correspond to local long-term agro-meteorological annual references and air

temperature data (Slavov, 1984). Crop coefficient factors adjusted to Bulgarian weather conditions are involved in the analysis (Popova & Feyen, 1996). Total Available soil Moisture content (TAM, mm/m), defined as the difference in soil moisture content between field capacity and wilting point, has been evaluated to be 132.6 mm for this case study.

The different irrigation scenarios correspond to certain thresholds of water depletion expressed as Readily Available soil Moisture (RAM, mm/m). These thresholds of RAM might vary within the season in accordance to crop sensitivity to water deficit in the root zone during the different stages of maize development. Water application is scheduled whenever the critical soil moisture level RAM is reached and application depth is set equal to the depleted soil water in the root zone. In the first scenario of irrigation RAM was set to "0.2TAM, 0.2TAM, 0.3TAM and 0.8TAM" at the initial, development, mid season and late season stages respectively (Raes *et al.*, 1986; Popova & Feyen, 1996). RAMs correspond to depletion to 90, 90, 85 and 38% of Field Capacity –FC in that case. In scenario number 2 it was set to "0.4TAM, 0.4TAM, 0.4TAM (depletion to 76% FC) (Doorenbos & Kassam, 1979) and 1.0TAM". With the latter scenario soil water depletion up to 1.0TAM (or to wilting point) practically means that no water is applied in "late season" stage. The third scenario corresponds to maize cultivation under entirely stored soil water. N-application rate is set to 200 kg N/ha/year for all scenarios. Thus N is not a limiting factor in this study.

Simulations are performed for certain representative years indicated in the boxes in Figure 62 to Figure 65. They correspond approximately to Probability of Exceedance $P=0$ (wet climate), 25 (moderately wet), 50 (medium), 75 (moderately dry) and 100% (dry). Simulated water and N-fluxes (below 1.25 m) have been used for risk assessment analysis over the whole studied period.

The risk of groundwater pollution during a certain season was analysed over the complete cycle of vegetation and the following post-vegetation periods. It was studied in terms of drainage and N-leaching below the root zone (1.25 m) over the period from May to September (Figure 62 and Figure 63 for vegetation) and from October to April (Figure 64 and Figure 65 for the fallow state of the field). The risk is related to the probability of exceedance of thirty-year series of precipitation totals $P(\%)$. Extremes seasonal precipitation (vegetation of 1976 and post-vegetation of 1962-3) result in substantial water drainage over all treatments ranging from 200 to 461 mm for the complete cycle, that is 40-48% of total water supply over vegetation and post-vegetation (Figure 62 and Figure 64). Not only N-leaching depends upon the climate characteristics over the complete cycle but also it is predetermined by the rate of nitrogen up-take by the plants. The highest risk to groundwater occurs in the case of "a dry" vegetation followed by "a wet" post-vegetation (1962-3) when 59.4 kg N/ha (30% of N applied) are leached at the dryland treatment (Figure 65).

It is obvious that the risk to environment varies over different water application scenarios and particular seasons. The effect of environmentally oriented irrigation scheduling, referred to as scenario 2 in Figure 62-Figure 65, on drainage reduction is substantial in years of "medium to moderately dry" and "dry" post vegetation, which corresponds to the cases of Probability of Exceedance below 40% in Figure 64. It is observed that drainage associated with environmentally oriented irrigation scheduling (presented by triangles there) is almost equal to that simulated without irrigation (presented by diamonds) for the values of $P>40\%$. In that case Potentially Extractable Soil Water (PESW - CERES output) drops at the end of the vegetation and thus makes possible additional storage of heavy rains occurring during late season and maturity or later in the soil. The effect of deep percolation reduction with the scheduling referred to as environmentally oriented (scenario 2) in 1960 is evaluated to be 95 mm/cycle.

Lack of water supply during "late season" phase of maize development is associated with negligible reduction of yield. The latter is within the limits 0.7%-7% of potential productivity.

Established effect should be emphasised at higher fertilisation rates and soils of higher water retention.

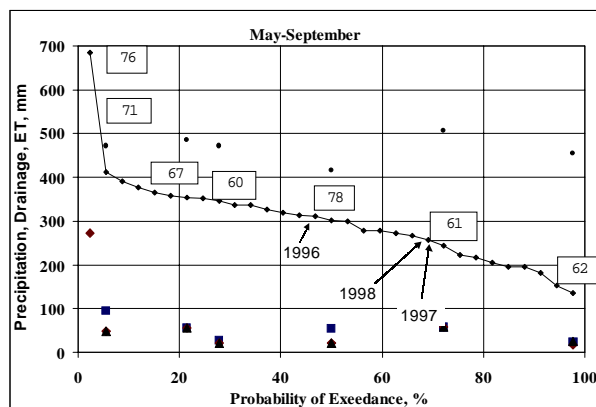

Figure 62. Drainage & evapotranspiration vs. P(%) for maize vegetation

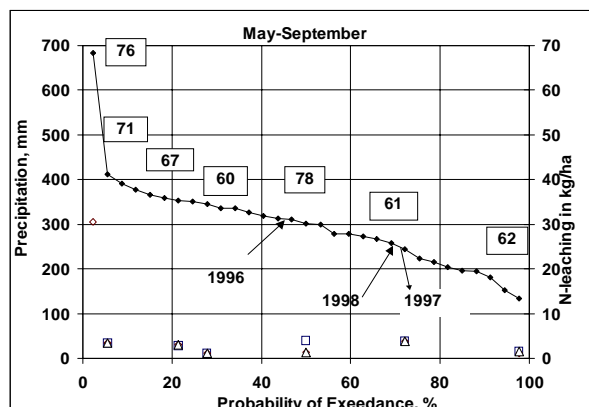

Figure 63. N-leaching vs. P(%) for maize vegetation

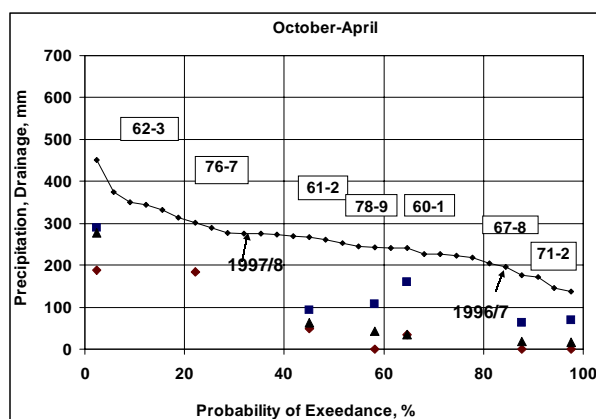

Figure 64. Drainage vs. P(%) for fallow state of the field

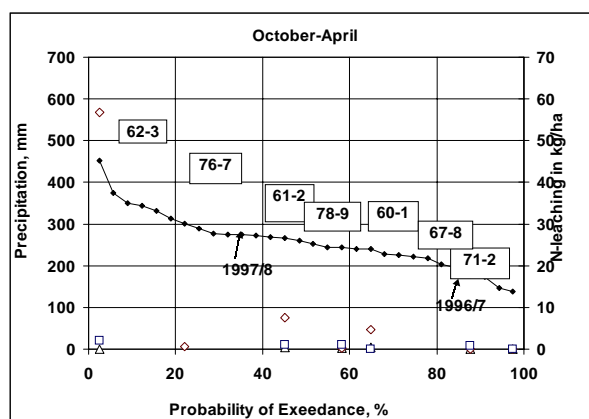

Figure 65. N-leaching vs. P(%) for fallow state of the field

Figure 62-Figure 65. Modelled Drainage (Figure 62 and Figure 64) and Nitrate leaching (Figure 63 and Figure 65) in relation to Probability of exceedance of rainfall totals P (1960-1990) for maize vegetation period (May-September) and fallow state of the field (October-April). In the four figures, squares (■) represent the treatments "0.2TAM, 0.2TAM, 0.3TAM, 0.8TAM", triangles (▲) represent the treatments "0.4TAM, 0.4TAM, 0.4TAM, 1.0TAM" and the diamonds (◆) represent the treatments without irrigation. Open symbols are for Nitrate leaching, closed ones for drainage. In Figure 62 the circles (●) represent Potential EvapoTranspiration. The simulated years are indicated in the boxes.

6.3. Fundulea (Wheat)

6.3.1. Experiment description

Fundulea is at about 30 Km East of Bucharest. The arable land of the local research institute is part of a transition area between Vlasia and Southern Baragan Plain, along the Mostistea River. Its geographical location is 44°33' northern latitude and 24° 10' eastern longitude. The relief is generally flat, having an average altitude of 68 m.

6.3.2. Measurements

Humidity, ammonium and nitrate contents as well as mineralization capacity of 5 soil layers, phenology, dry-matter and nitrogen content (Kjeldahl) from different plant organs were measured in dynamics. Soil water was determined by gravimetry, ammonium was measured by colorimetry at 410 nm after extraction with a mixture of Seignette salt and Nessler solution. After incubation with potassium sulfate, extract dissolved in a solution (1:10) of phenoldisulphonic acid was measured with a colorimeter at the same wavelength in order to find soil nitrogen contents.

Plants were partitioned into leaf, stem and spike. Leaf area was determined manually by measuring leaf's width and length. All samples were dried at least 72h at 65°C before determining the dry matter weight. Nitrogen was determined for all samples by Kjeldal digests (Persson, 1996). Phenological development was recorded when 50% of the plants had reached a particular stage.

Daily values for minimum, maximum temperature, rainfalls and sunshine duration were obtained from Fundulea weather station included in the network of the National Institute for Meteorology and Hydrology Fundulea.

6.3.3. Treatments and replicates

Two experiments were performed in the field of the Laboratory for Irrigation Laboratory in vegetation seasons 1996-1997 and 1997-1998. A split-plot design with three replicates was used in both experiences, with the following factors:

- factor A level of watering:
 - A1- non-irrigated
 - A2 - well irrigated treatment
- factor B: level of nitrogen fertilisation:
 - B1 - non-fertilised
 - B2 - optimum fertilised (100 kg N/ ha)
 - B3 - over fertilised (200 kg N/ ha)

6.3.4. Results synthesis

In 1996-1997, wheat yield under non-irrigated conditions ranged from 3399 kg/ha in non-fertilised variant to 6300 kg/ha in variant fertilised with 200 kg N/ha. Yield of irrigated variants ranged from 2847 kg/ha to 5906 kg/ha for the same fertilisation levels.

For 1997-1998, the grains yield in non-irrigated conditions ranged from 3833 kg/ha in non-fertilised variant to 6184 kg/ha in variant fertilised with 200 kg N/ha. In irrigated variant grain yield ranged from 3488 kg/ha in non-fertilised variant to 5698 kg/ha in variant fertilised with 200 kg N/ha. Because the first part these years was very wet, it was meaningless to study the influence of irrigation in wheat. Only the nitrate application induced significant differences.

Nitrate quantity from soil was minimum in June for the whole soil profile analysed (90 cm) and was also reduced in March, higher values appearing in superficial layer. N-NO₃ quantity increased especially in fertilised variant with maximum dose of nitrogen and in the superficial layer in May. The analyses made in June evidenced a small nitrate quantity and a correlation of this with applied dose of nitrogen. Regarding the results from this sampling date, we think that the smaller nitrate quantities from soil are due the higher wheat crop consumption.

Dry matter accumulation in above ground vegetative plant organs was enhanced by the favourable conditions from the autumn and the first part of the winter of 1996. The cold weather from February–March explains the lower values from the next sampling date. In spring 1998, decrease in DM, due to leaf senescence and a reduced number of tillers, was very

sharp. In the first experimental year, the plots fertilised with 200 kg N/ha presented, at the harvest, a double quantity of DM in vegetative organs, and this was associated with a similar increase of yield. Logistic regression equations for describing grain filling were calculated according to Darroch & Baker (1990). For Romanian winter-wheat genotypes, there are considerable differences relative to the three coefficients of mentioned equation (Lazar & Saulescu, 1996), but for this experiment with cultivar Flamura 85, no significant difference was found between treatments. The maximal level of DM accumulation in kernel was 57.39 mg, the duration of grain filling was 746.5°Cday, the maximum rate of grain filling was 0.127 mg/°Cday.

Although nitrogen content determinations in winter wheat were performed both in plots designated for irrigation and in rainfed plots, only the mean values will be taken into account. Nitrogen content in leaves was almost constant till the end of March, when a decreasing trend appeared. The differences were proportional with nitrogen fertilisation rate, and they became greater than two standard deviations in May (Figure 66). A similar observation is valid for nitrogen content in stem (Figure 67).

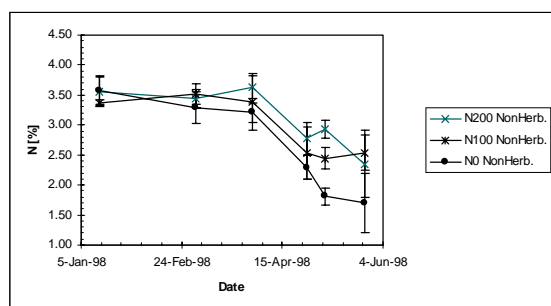

Figure 66 Influence of nitrogen fertilisation on nitrogen content of leaves in winter wheat (Fundulea 1998)

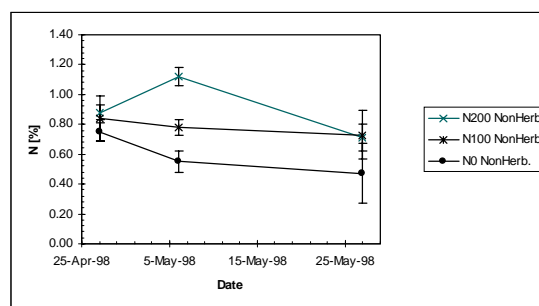

Figure 67: Influence of nitrogen fertilisation on nitrogen content of stems in winter wheat (Fundulea 1998)

An influence of nitrogen applications on leaf area is visible from April but the differences are less than two standard deviations. An explication for this “lack of separation” of the applied treatments in 1998 on winter wheat may consist in low differences found for the soil nitrogen.

6.3.5. CERES model calibration

CERES-Wheat model (INRA) version was calibrated for the Cambic-Chernozem of Fundulea using the field data from optimum variant (N100, irrigated) cultivated in 1996-1997. After adjusting of the A, gamma and Ksat values small changes in values of field capacity and saturation capacity (calculated from granulometric data) were enough to obtain a reasonable description of water dynamics in soil especially for the last layer (Figure 68). Further improvements were obtained, changing the root distribution factor from different layers. CNTOT and initial nitrogen values were changed in order to improve the nitrogen movement in soil. The nitrate content from the bottom soil layer received a higher priority (Figure 69). The model seems to describe poorly ammonium soil content, but a validation of measurements method is in progress.

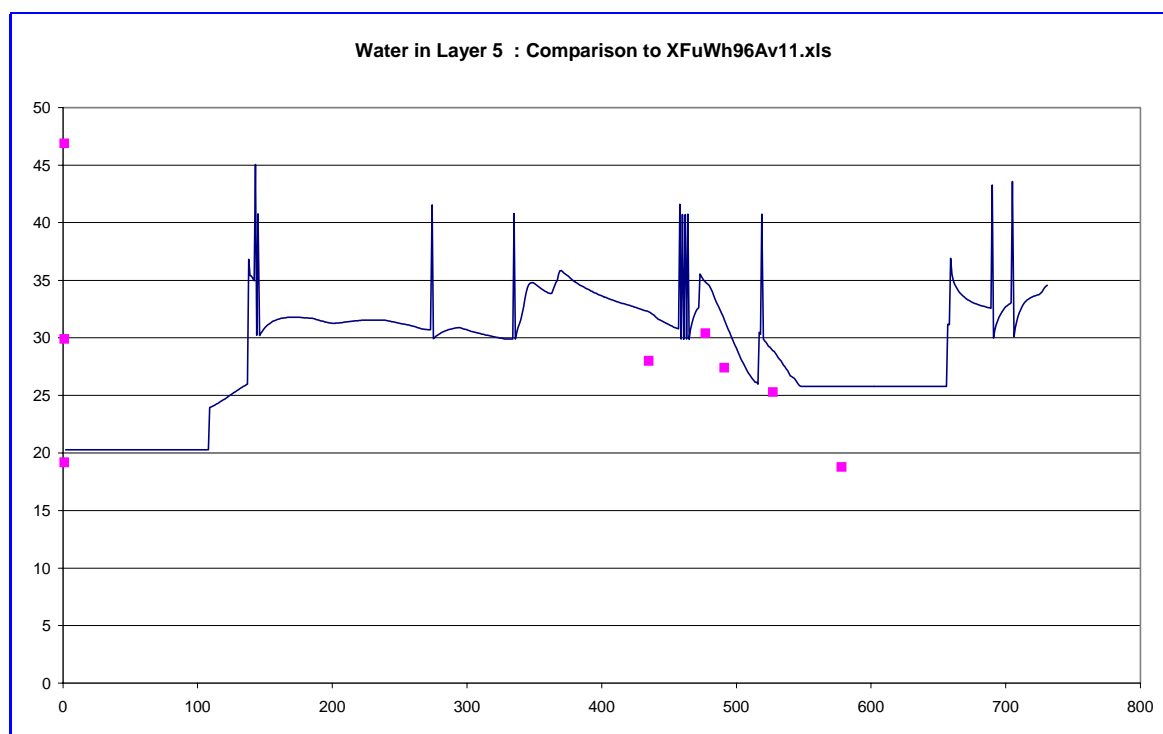

Figure 68: Observed (squares) and simulated (continuous line) volumetric water content (%) in soil layer 5 vs. number of days after beginning of simulation (1-Jan-1996) –Winter wheat, irrigated and fertilised with 100 kg N/ha - Fundulea 1996-1997

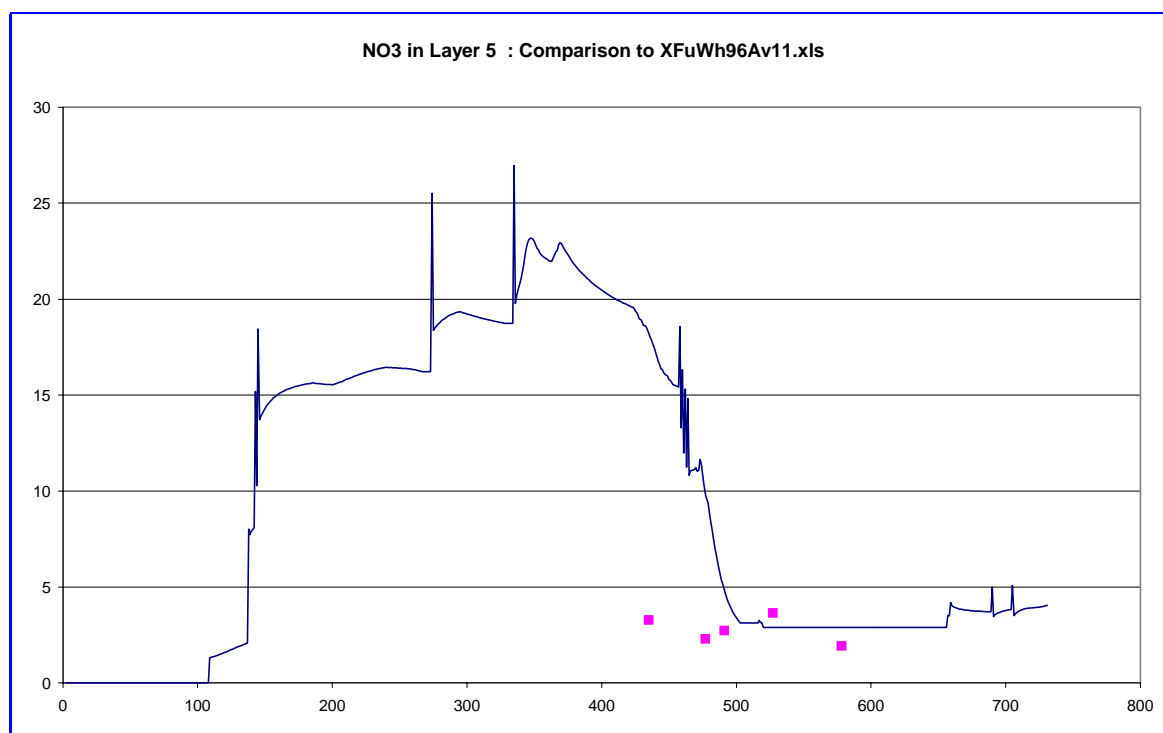

Figure 69: Observed (squares) and simulated (continuous line) nitrate content (kg N/ha) in soil layer 5 vs. number of days after beginning of simulation (1-Jan-1996) –Winter wheat, irrigated and fertilised with 100 kg N/ha - Fundulea 1996-1997

The cultivar-dependent parameters for Flamura 85, were taken from a previous study (Lazar, 1999) and they ensured a fair simulation of phenology. Regarding simulation of DM partition (Figure 70) there is a large difference from observed value for the final total biomass, but there is a small underestimation of grain filling.

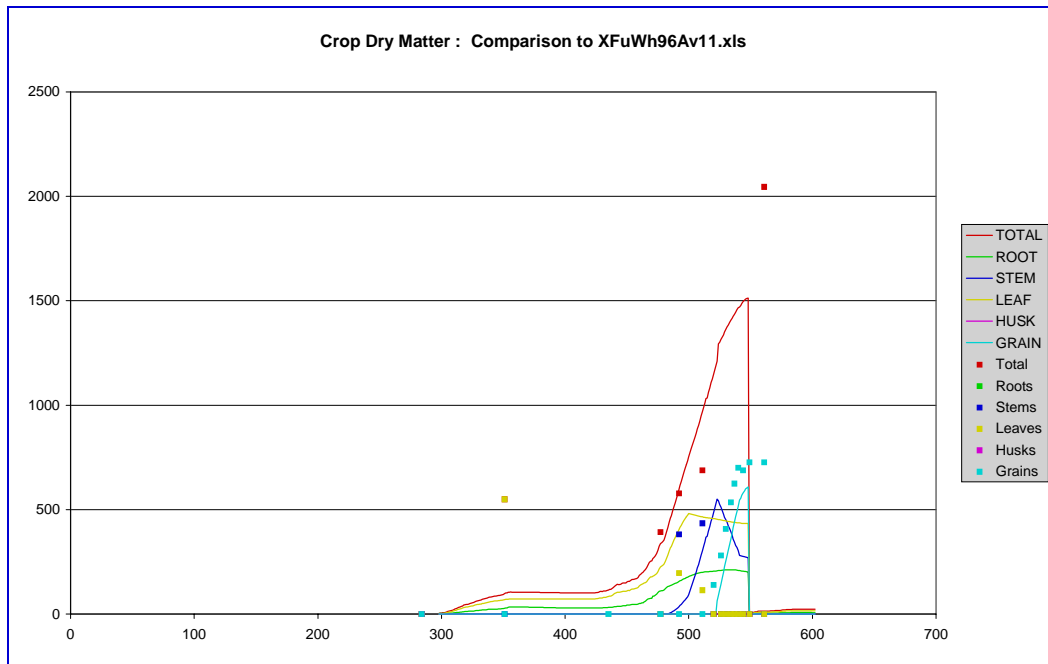

Figure 70: Observed (squares) and simulated (continuous line) DM in plant organs (g/m²) vs. number of days after beginning of simulation (1-Jan-1996) –Calibration data set: Winter wheat, irrigated and fertilised with 100 kg N/ha - Fundulea 1996-1997

6.3.6. Model validation

Observed values from the other treatments combinations were used for model validation. For 1997-1998 vegetation season, simulations for soil water were in a good agreement ($R^2=0.887$) with field data (Figure 71).

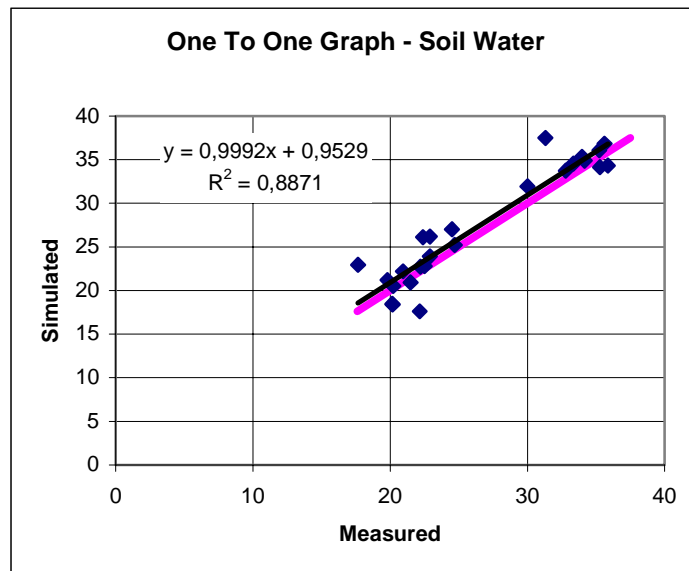

Figure 71: Simulated vs. measured soil water (%). Winter wheat, irrigated, herbicided and fertilised with 100 kg N/ha - Fundulea 1997-1998

Soil nitrogen conclusions from the model calibration part are, also, fitted for validation data set. Total DM is better simulated but there is an underestimation of early stem DM allocation and of leaf senescence (Figure 72). In spite of all mentioned discrepancies, the model proved to be a useful tool for evaluating water and nitrate from soil.

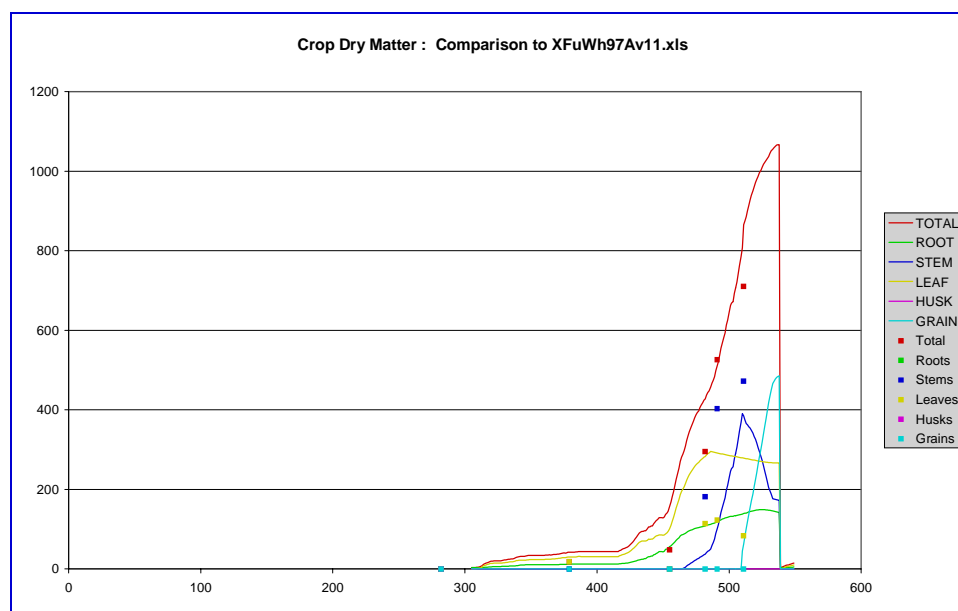

Figure 72: Observed (squares) and simulated (continuous line) DM in plant organs (g/m²) vs. number of days after beginning of simulation (1-Jan-1997) –Validation file: Winter wheat, irrigated and fertilised with 100 kg N/ha - Fundulea 1997-1998

6.3.7. Utilisation for one crop and bare soil

For evaluating limits of variation of simulated grain yield, drainage and nitrate leaching the model for wheat was run for 9 treatments (scenarios) in 7 years. Treatments applied consisted in combinations of two sowing days (15th September and 6th October), three nitrogen fertilisation levels (0, 100 and 200 kg N/ha) and irrigation application (only for the simulations of the plots sown on 15th September). An irrigation, with amount 75 mm, was applied after stage 3 (beginning of ear growth), then and only then when potential extractable soil water dropped below half of PESW value for field capacity. A 34-year long daily weather data set for Fundulea was used to calculate the probabilities of exceedance for cumulated rainfalls for winter wheat season and separately for the period of bare soil. The simulation years were chosen with intention to be representative for both considered periods. Settings like soil data and cultivar were those from calibration parameter file. Simulated grain yield varied from 662 kg /ha (for irrigated, non-fertilised plots in 1979) to 7720 kg /ha (for irrigated, fertilised, 1969).

For the September-July period, it is a visible tendency for drainage to increase with cumulated rainfalls, but distribution of rainfalls and plant uptake may decrease the amount of lost water (1990). Due to a better development of root system, under irrigated condition, plots fertilised with 200 kg N/ha, may present a smaller drainage than unfertilised plots, like in years 1979 and 1986 (Figure 73). This is followed by lower nitrogen leaching in plots fertilised with 200 kg N/ha, for these two years. For plots sown on days 15th September, the highest value for nitrate leaching (32.1 kg N/ha) was obtained in 1979 for mentioned combination (N200, rainfed).

Comparatively with plots sown in September, the plots sown in October presented, in average, nitrate leaching levels twice larger. For plots sown in October the maximum nitrate leaching was 75 kg N/ha in 1969 for plots fertilised with 200 kg N/ha). For the second sowing date, only simulations for rainfed were performed. Nitrate leaching in plots fertilised with a moderate nitrogen dose 100 kg N/ha was closer to the level of N0 variants for the first sowing date at the middle of levels from N0 and N200 variants for the second sowing date.

During the bare soil period, with exception of 1993, applied scenario for irrigation had a minimal residual impact on drainage and nitrate leaching. In concordance with increased drainage, in 1990, a maximal nitrate leaching of 4 kg N/ha was obtained (Figure 74).

Selected scenarios, (N0, N100, N200 and rainfed vs. an “economical” irrigation strategy) are common in Romanian agricultural practice. For winter wheat sown in the middle of September drainage risk is under 250 mm for the vegetation period and nitrate leaching is under 35 kg N/ha, three weeks later the values are 300 mm and respective 70 kg N/ha. Risks for bare soil period are minimal.

The unexpected variation induced by sowing date pointed out the necessity to include new scenarios for this factor as well as for higher nitrogen applications.

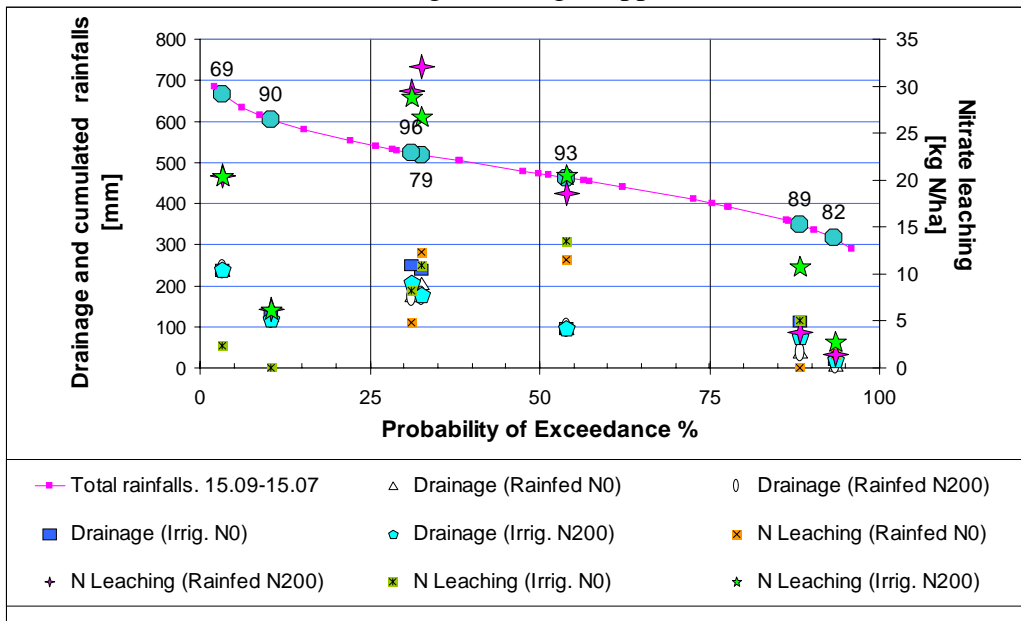

Figure 73: Model drainage and nitrate leaching in relation to probability of exceedance of cumulated rainfalls for the winter wheat vegetation period (15 September-15 July)

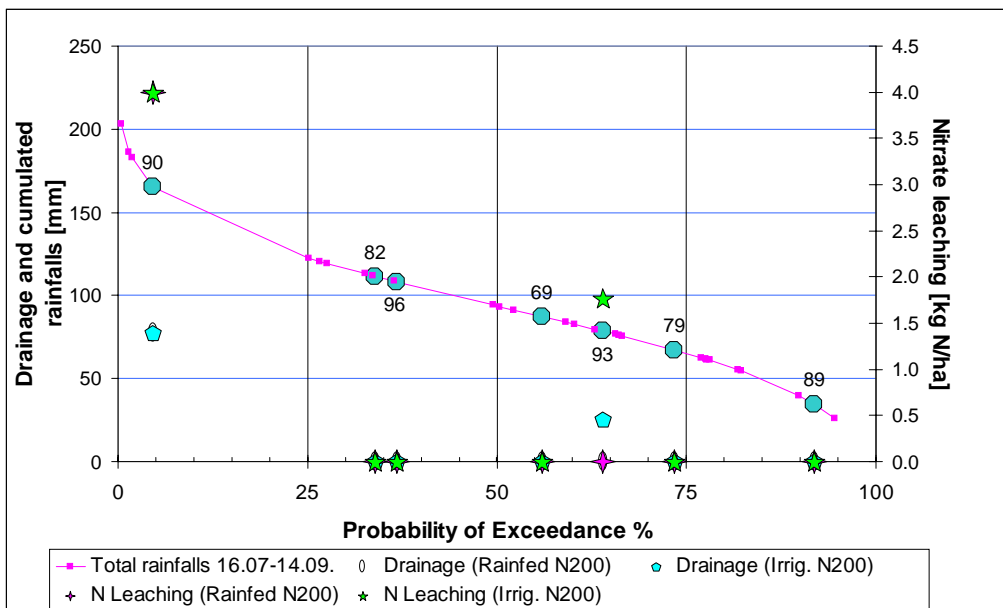

Figure 74: Model drainage and nitrate leaching in relation to probability of exceedance of cumulated rainfalls for the bare soil period after winter wheat crop (16 July-14 September)

6.4. Fundulea (Maize)

6.4.1. Treatments and replicates

Two experiments were performed in the field of the Laboratory for Irrigation Laboratory in vegetation seasons 1997 and 1998. A split-plot design in three replicates was used in both experiments with the following factors:

- factor A: level of watering:
 - A1- non-irrigated
 - A2 - well irrigated treatment
- factor B: level of nitrogen fertilisation:
 - B1 - non-fertilised
 - B2 - optimum fertilised (200 kg N/ ha)
 - B3 - over fertilised (400 kg N/ ha)

6.4.2. Results synthesis

Due to a different distribution of rainfalls in 1997 and 1998, combined with a “economical irrigation schedule” in the first year and in the second year with a schedule aimed to keep the soil humidity above the limit of 80% of the difference between field capacity and wilting point, the effect of irrigation applications on potential extractable soil water (PESW) was very different. In 1998, after a rainy spring followed a dry summer, and the soil water decreased sharp and this process was more obvious in the first layer.

There were increasing trends of soil nitrate contents in 1997 in all fertilised plots and the level of content was greater in plots fertilised with 400 kg N /ha. In contrast with the situation of 1997, the soil nitrate contents in the dry summer of 1998 were lower than average level of the previous year, with exception of irrigated and over-fertilised plots. For irrigated plots the most important feature is represented by the high level of nitrate concentration in the N400 plots comparative with the moderate value from N0 or even N200 plots (differences exist between these two variants, but, they are smaller). It is obvious that nitrate content from irrigated and over fertilised plots exceeds the requirements for plant uptake capacity.

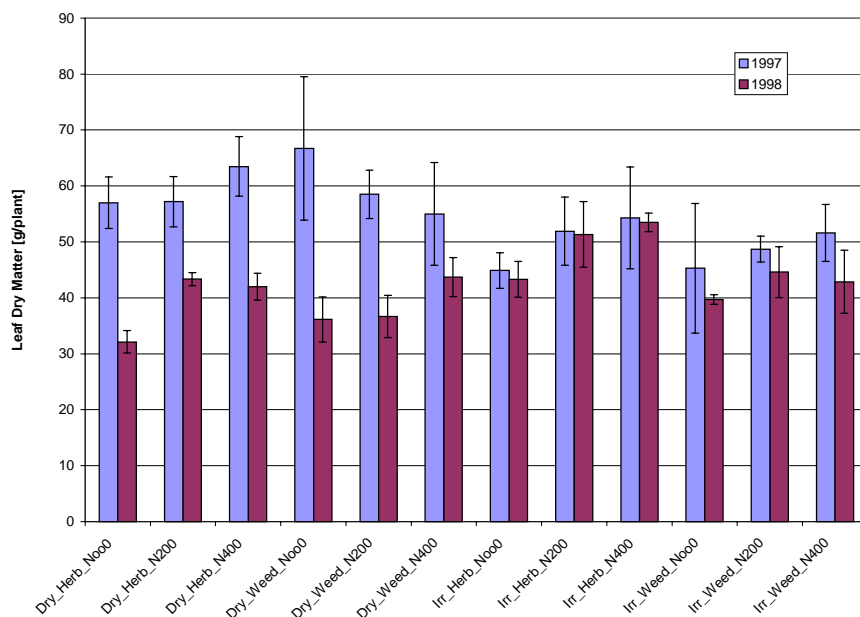

Figure 75: Final dry matter accumulated in maize leaves (Fundulea 1997-1998)

With the exception of final samples from irrigated plots in 1998, leaf area index was not influenced significantly by nitrogen applications. The maximal observed value was 3.73 m²/m² for the irrigated plot fertilised with 400 kg N/ha.

The available soil water influenced the dry matter accumulation in different plant organs (Figure 75 and Figure 76). For example, leaf dry matter (DM) from non-irrigated plots was significantly lower in 1998 compared with 1997. Irrigation suppressed the significant differences between leaf DM obtained in those two years. A lower accumulation of dry matter in kernel was observed in rainfed plots from 1998. But, the highest values were obtained in the case of irrigated and high fertilised plots in the year 1998.

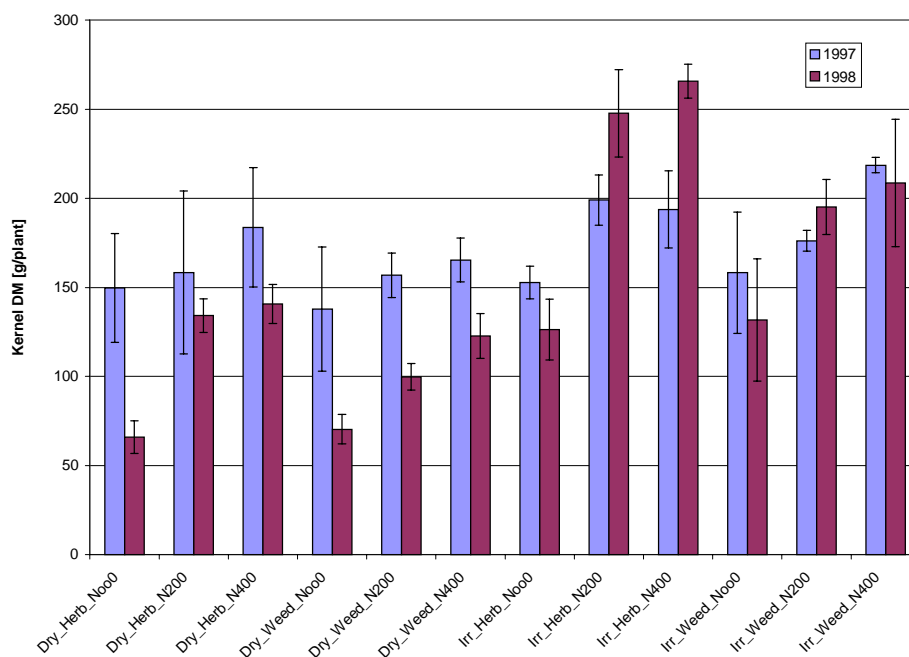

Figure 76: Final dry matter accumulated in maize kernels (Fundulea 1997-1998)

6.4.3. CERES model calibration

The model CERES-Maize improved in INRA was calibrated for the Cambic-Chernozem of Fundulea using the field data from optimum variant (N200, irrigated, herbicided). Most of the soil descriptors were kept at values close to those from the input file for wheat, with the exception of the G2 (maximum number of kernels/plant), which was obtained from the information provided by breeders, the other cultivar-dependent parameters were fitted step by step to produce valid phenological behaviour. Although there are still large differences between observed and simulated data for soil water dynamics (Figure 77) and the ammonium subroutine needs to be fixed, the model is able to simulate properly the water dynamics and it offers acceptable values of nitrate for most of the soil layers (Figure 78). For the field data, standard deviations larger than 5 kg nitric nitrogen/ha were obtained for some plots.

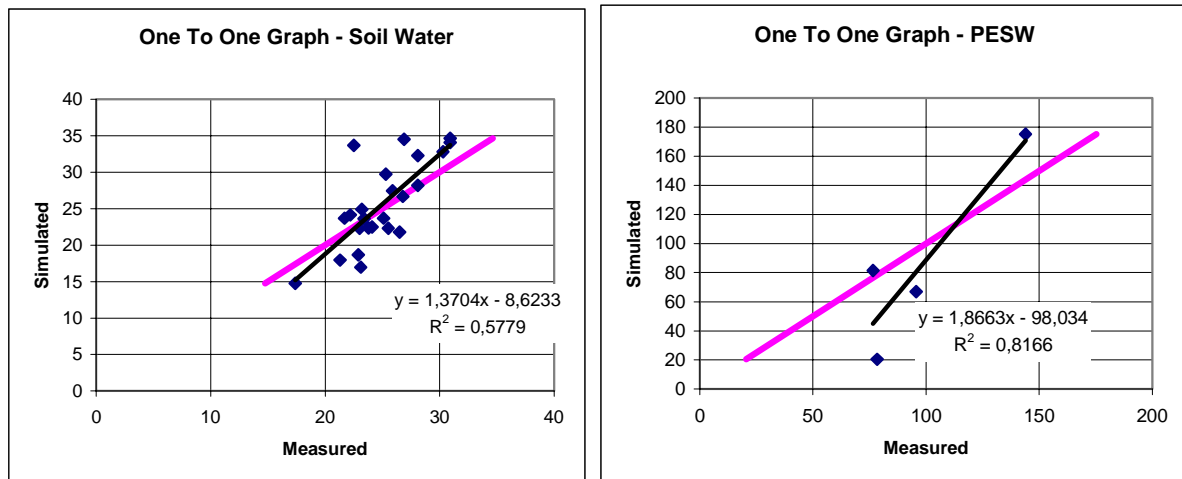

Figure 77: Measured versus simulated values for soil water (left) and potential extractable soil water (right) for the maize plots irrigated, herbicided and fertilised with 200 kg N/ha

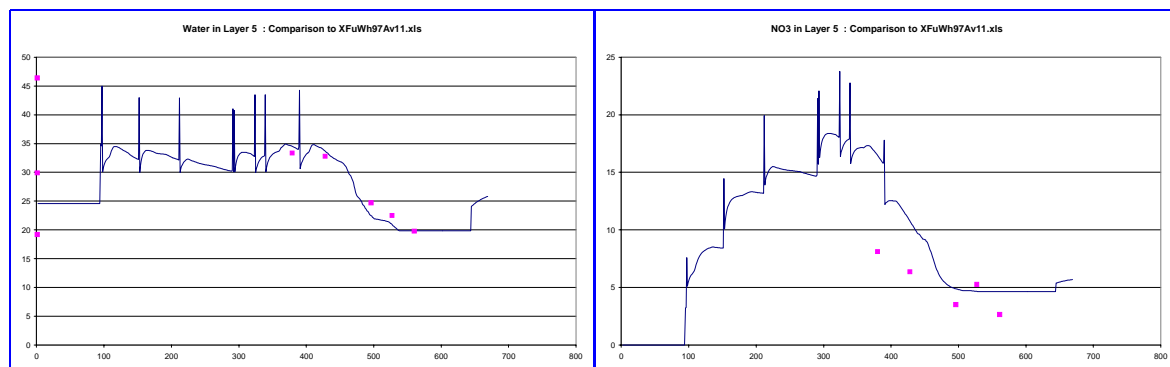

Figure 78: Dynamics of measured (squares) and simulated (continuous line) values for volumetric soil water content [%] (left) and nitrate soil content [kg N/ha](right) for the maize plots irrigated and fertilised with 200 kg N/ha (Fundulea 1997)

6.4.4. Model validation

Simulations of soil water content for 1998 were in agreement with field observations, especially in layers 3 to 6 (Figure 79). Taking into account all experimental data, there is a strong linear relationship between simulated and observed potential extractable soil water ($R^2 = 0.863$), but there is an underestimation of PESW in dry conditions and an overestimation in wet period or for the effect of irrigation (Figure 80).

Water in Layer 5 : Comparison to XFuMz98Av11.xls

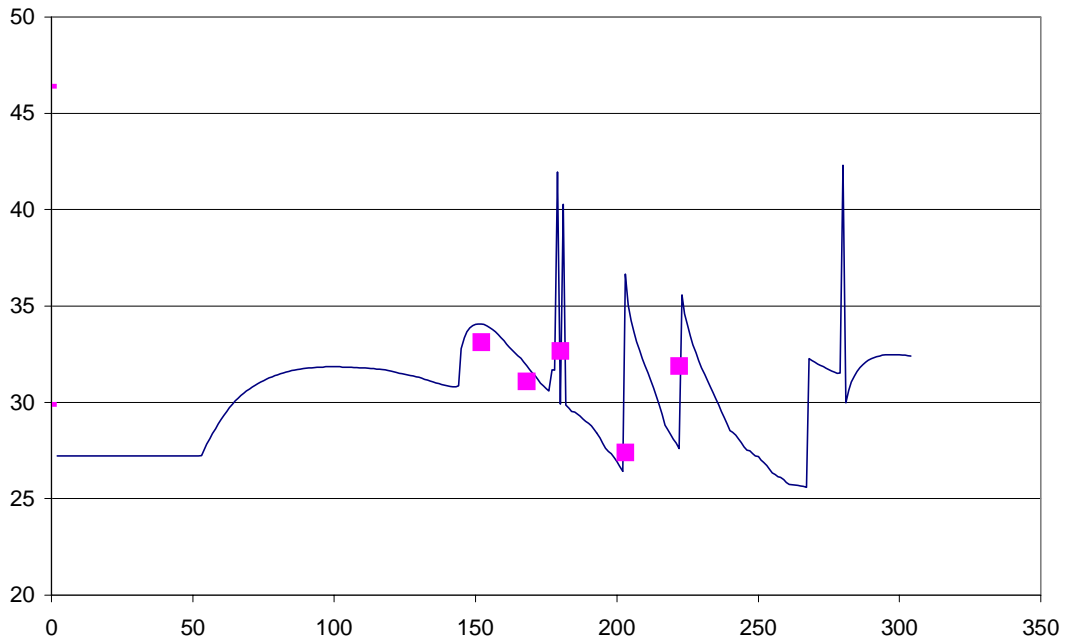

Figure 79: Dynamics of measured (squares) and simulated (continuous line) values for volumetric soil water content [%] for the maize plots irrigated and fertilised with 200 kg N/ha (Fundulea 1998)

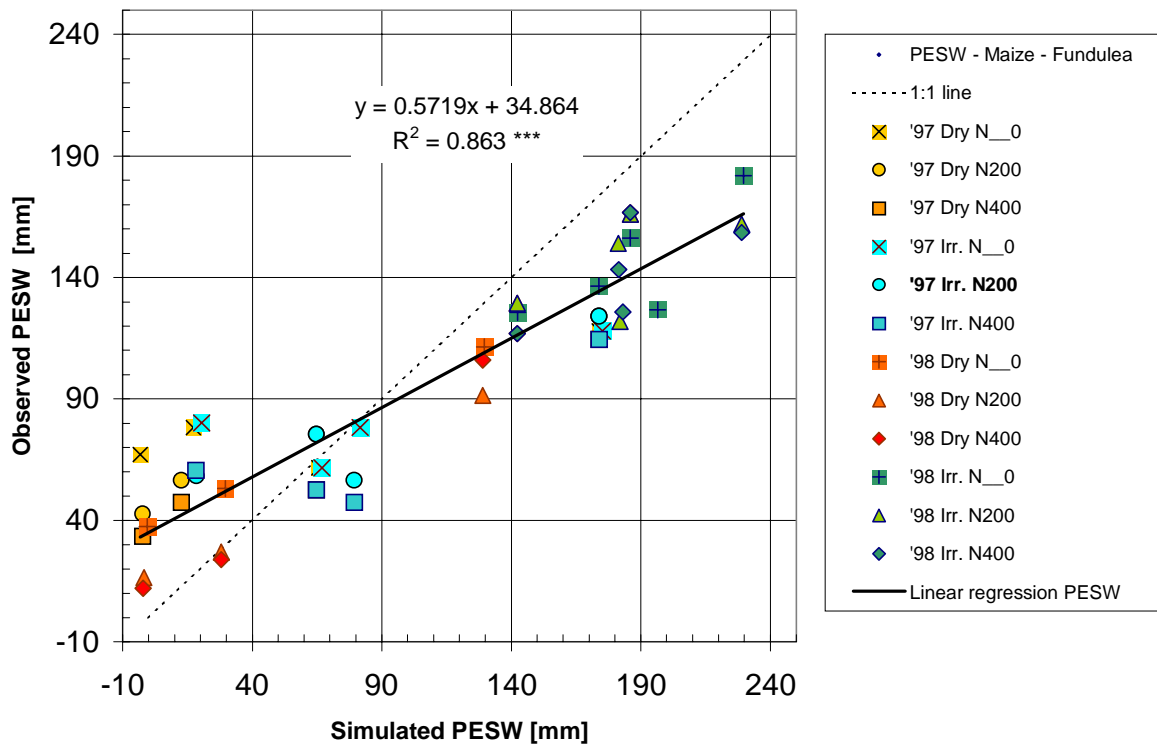

Figure 80: Relationship between simulated and observed PESW for maize crop (Fundulea, 1997 and 1998)

Experimental plots			Regressions simulated vs. observed			Number of Observations
Water	Nitrogen	Year	Slope	Intercept	r	
Dry	Noo0	97	0.165	5.265	0.339	24
Dry	N200	97	0.063	12.963	0.092	24
Dry	N400	97	0.364	12.508	0.578	24
Irr	Noo0	97	0.074	5.068	0.646	24
Irr	N200	97	-0.061	19.696	-0.049	24
Dry	N400	97	0.020	28.307	0.025	24
Dry	Noo0	98	0.071	7.706	0.086	24
Dry	N200	98	0.156	10.386	0.501	24
Dry	N400	98	0.074	20.362	0.622	24
Irr	Noo0	98	0.046	8.132	0.059	24
Irr	N200	98	0.037	14.248	0.188	24
Irr	N400	98	0.106	25.700	0.408	24

Table 6: Linear regressions for simulated vs. observed soil nitrate (kg N/ha) in different experimental plots (data from all layers)

The performances of calibrated model for predicting nitrate content of soil are shown in Table 6. A source of serious problems is the behaviour of first layer (Table 7).

Regarding the simulation of accumulation of dry matter in plant organs, the grain filling is fairly described (a high correlation coefficient and a slope very close to 1). Simulated leaf area index was often below the values measured in field, but the correlation coefficient is very significant (Table 8).

	layer 1	layer 2	layer 3	layer 4	layer 5	layer 6
Slope	0.032	0.471	0.497	0.669	0.400	0.615
Intercept	35.62	10.30	4.80	4.15	6.61	4.60
r	0.070	0.650	0.646	0.562	0.382	0.390

Table 7: Linear regressions for simulated vs. observed soil nitrate (kg N/ha) in different layers (data from all experimental plots, 48 observations for each layer)

	Dry matter in			LAI
	Stems	Leaves	Grains	
Slope	0.311	0.606	0.932	1.292
Intercept	120.5	168.8	-91.0	0.1
r	0.649	0.596	0.785	0.948
Obs. (#)	32	31	45	24

Table 8: Linear regressions for simulated vs. observed dry matter accumulation in different organs and leaf area index (LAI)

6.4.5. Utilisation for one crop and bare soil

For the study of relationships between drainage and nitrate leaching in case of maize crop, the CERES model for maize was run for 18 treatments (scenarios) in 7 years.

Treatments applied consisted in combinations of three sowing days (1st April, 20th April and 6th October), three nitrogen fertilisation levels (0, 200 and 400 kg N/ha) and irrigation application. One irrigation, with fixed amount 100 mm, was applied after stage 3 (beginning of ear growth), when potential extractable soil water dropped below half of PESW value for field capacity.

A 34-year long daily weather data set for Fundulea was used to calculate the probabilities of exceedance for cumulated rainfalls for maize season and separately for the period of bare soil. The simulation years were chosen with intention to be representative for both considered periods. For taking into account the influence of the sowing date, drainage and nitrate

leaching were cumulated (for each simulation) from sowing day to maturity and from that day to the sowing day of the next year (for bare soil period).

A special attention was paid for extending the facilities of batch-processing required for the extensive exploitation and a further model improvement. The batch processing was ensured by a Visual-Basic program.

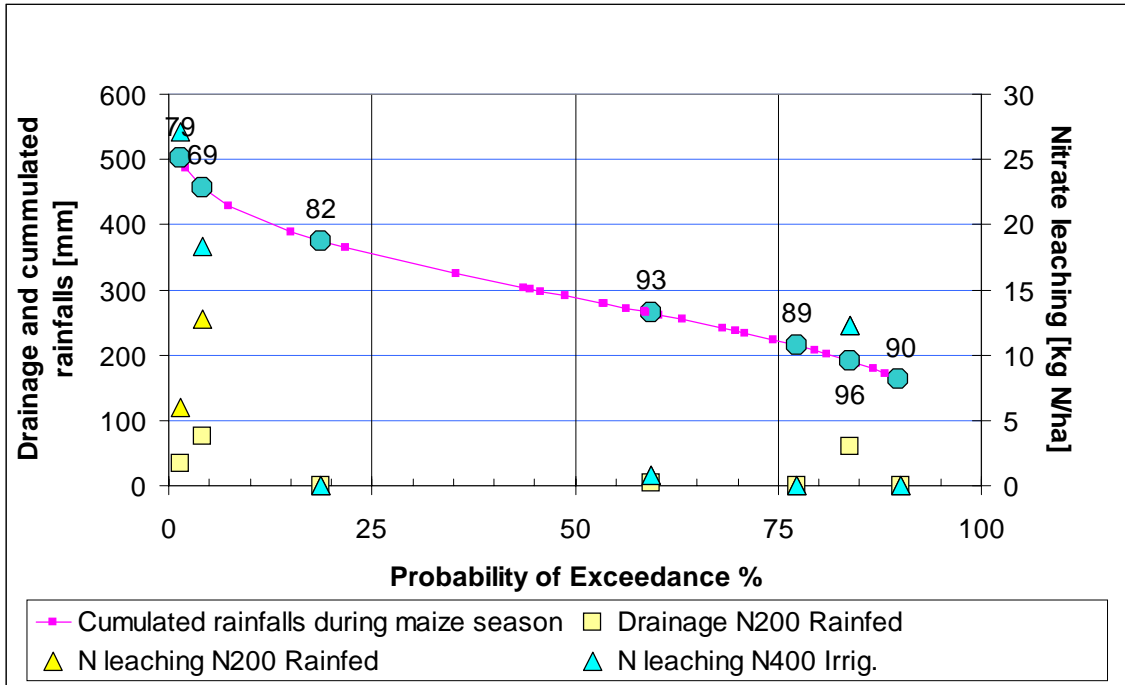

Figure 81: Model drainage and nitrate leaching in relation to probability of exceedance of cumulated rainfalls for the maize vegetation period (April-September)

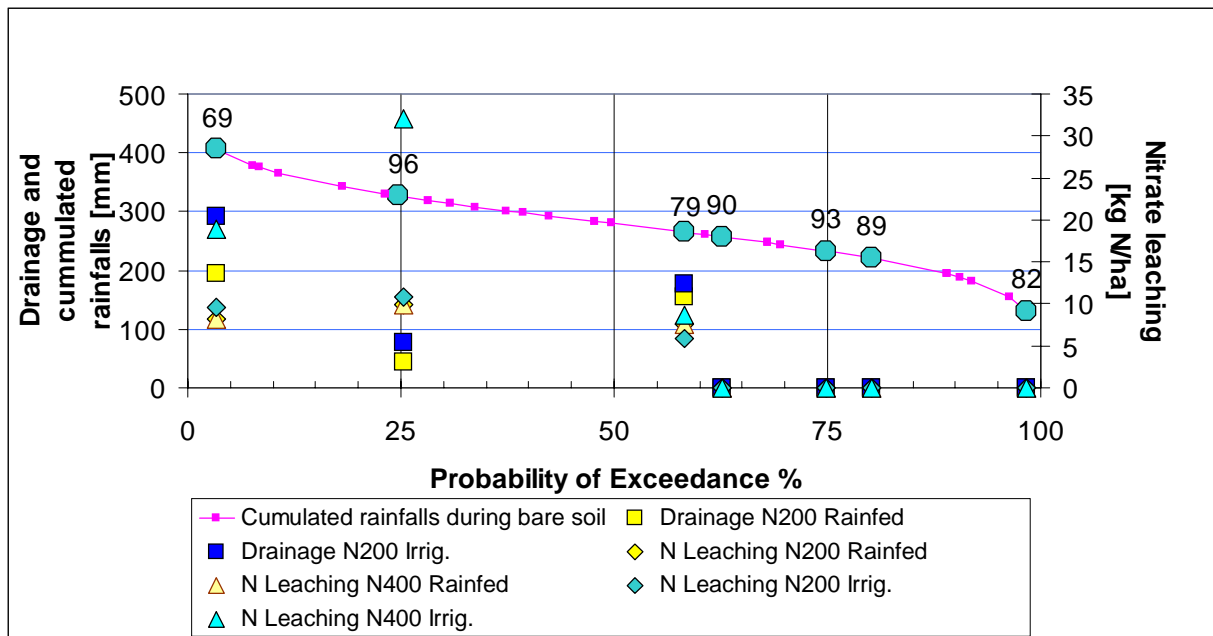

Figure 82: Model drainage and nitrate leaching in relation to probability of exceedance of cumulated rainfalls for the bare soil period after maize crop (September-April)

Drainage and nitrate leaching of the plots sown on 20th April is presented in Figure 81 (vegetation period) and Figure 82 (bare soil). For maize vegetation period, years with larger drainage values were 1979, 1969 and 1996 in all scenarios. In these years nitrate leaching was also larger, especially for over-fertilised plots. For some years, during the period of bare soil,

the drainage and nitrate leaching was greater than in maize vegetation period. A “residual” effect of irrigation on nitrate leaching from bare soil period was observed in 1969 and 1996. One may notice an increasing nitrate leaching for the late sowing date, up to 35 kg N/ha. With three exceptions, linear relationships between drainage and nitrate leaching in vegetation (Table 9) and bare soil period (Table 10) were found for the majority of scenarios. In conclusion, for the considered scenarios, nitrogen leaching is correlated with water lost by drainage, there is a strong influence of nitrogen application and sowing dates.

Scenarios			Linear regressions			Maximum N Leaching (kg N/ha)
Sowing day	Irrigation ¹ mm	Nitrogen (kg N/ha)	Slope	Intercept	r	
1-Apr	0	0	0.091	0.944	0.749	12.2
		200	0.149	0.389	0.989	13.1
		400	0.227	-0.307	0.997	20.6
	100	0	0.091	0.944	0.749	12.2
		200	0.149	0.405	0.989	13.1
		400	0.227	-0.313	0.997	20.6
10-Apr	0	0	0.126	0.242	0.806	12.2
		200	0.143	0.400	0.981	11.2
		400	0.230	-0.303	0.996	19.2
	100	0	0.126	0.242	0.806	12.2
		200	0.144	0.400	0.979	11.2
		400	0.230	-0.295	0.996	19.2
20-Apr	0	0	0.078	0.806	0.623	12.3
		200	0.180	0.077	0.993	12.7
		400	0.227	-0.203	0.995	18.4
	100	0	0.051	0.900	0.524	12.3
		200	0.097	1.049	0.767	12.7
		400	0.239	-0.246	0.997	27.1

¹) Applied after stage 3 (beginning of ear growth) and only if potential extractable soil water (PESW) was lower than half of PESW value at field capacity

Table 9: Linear regressions for cumulated drainage (mm) during maize vegetation period as variable X and nitrate leaching (kg N/ha) as variable Y

Scenarios			Linear regressions			Maximum N Leaching (kg N/ha)
Sowing day	Irrigation ¹ mm	Nitrogen (kg N/ha)	Slope	Intercept	r	
1-Apr	0	0	0.048	0.004	0.999	8.4
		200	0.030	-0.120	0.959	6.0
		400	0.089	0.306	0.972	14.8
	100	0	0.030	0.220	0.968	7.6
		200	0.027	-0.137	0.986	7.8
		400	0.042	0.938	0.810	12.2
10-Apr	0	0	0.041	0.146	0.963	9.1
		200	0.031	0.495	0.913	5.8
		400	0.093	1.004	0.957	16.1
	100	0	0.024	0.282	0.983	7.2
		200	0.024	0.404	0.960	6.4
		400	0.040	2.077	0.736	12.8
20-Apr	0	0	0.039	0.484	0.905	8.6
		200	0.043	1.259	0.769	9.9
		400	0.110	2.024	0.891	20.5
	100	0	0.030	0.656	0.908	7.7
		200	0.033	1.198	0.772	10.8
		400	0.061	3.753	0.558	32.1

¹) Applied after stage 3 (beginning of ear growth) and only if potential extractable soil water (PESW) was lower than half of PESW value at field capacity

Table 10: Linear regressions for cumulated drainage (mm) for the bare soil period after maize crop as variable X and nitrate leaching (kg N/ha) as variable Y

6.5. Bucharest (Sugar beets)

6.5.1. Experiment description

The experiments were organised at the Experimental Field for Land Production, in the Didactic and Experimental Station which belongs to the University of Agronomical Sciences Bucharest, situated in the latitude of 44° 30' North and in the longitude of 26°13', 12 km away from Bucharest, to the North-East direction, in the great Romanian Plain.

The experimental field is situated at an altitude of 95 m, on a reddish-brown forest soil, whose main characteristics are a silt-clay texture (38 % clay), and a pH of 6.8; the wilting point and the field capacity were estimated to 13 % and 25 %, respectively.

6.5.2. Measurements

Soil data were measured by layers of 20 cm between 0 and 100 cm: water content (gravimeter); total nitrogen with Kjeldahl method, ammonium (N-NH₄) and nitrate (N-NO₃) determination from Bremner method.

Sampling dates: every other week (2 meters long/1 line; complete fresh weighing, drying of half). The dried weight of each organ was measured after 48h-drying at 60°C total nitrogen by compartment (Dumas method). In October, quality analyses were performed on root sugar content.

In every plot 3 plants were individualised, which were used for determinations without destruction of: the number and the dimensions of the expanding leaves and the expended leaves, the senescence. Leaves appearance was observed every 2 or 3 days by counting the new leaves that had appeared. Firstly every week, then every other week, the dimensions of the leaves were measured: length and maximum width of the leaf blades whose length was over 5 mm. Senescent leaves (more than 75 % of the leaf blade yellow) were noted and measured, but they were removed from the *LAI* calculation.

6.5.3. Treatments and replicates

Sowings were made on 29 April 1997 and 4 April in 1998. The genotype used was Emma. Each plot consisted in 14 rows, 6 m long, 50 cm apart, in 5 replicates, representing an area of 42 m². In the last years, fertilisers and pesticides amounts decreased constantly in Romania, on the one hand because of their high costs, and on the other hand because of farming policy that suppressed most of the subventions for agricultural production. For the sugar beet crops the rates of nitrogen fertilisers depend on: N-content of the soil, crop rotation, water balance, expected yield. The recommendations rates are 120-150 kg N/ha. The date of application is usually just before sowing. The experiments included three nitrogen treatments (0, 150 and 300 kg N/ha) with and without irrigation in order to obtain data sets in limiting and non-limiting conditions. They are referred as N0irr, N0dry, N150irr, etc, for 0-nitrogen irrigated, 0-nitrogen non-irrigated, 150-nitrogen irrigated, etc. Before ploughing in November, 100 kg P₂O₅ ha⁻¹ and 100 kg K₂O ha⁻¹ were applied.

6.5.4. Results synthesis

Figure 83 presents the production of dry matter and extractable sugar for the two years of experiments. In 1997, due to the unfavourable climatic conditions (the average temperature was very low, less than 15°C, and the rainfalls were abundant, more than 190 mm) the sowing was postponed to the end of April. The delay in sowing affected culture density and shortened the vegetation period. Consequently, the dry matter at harvest was reduced in all experimental treatments, as compared with 1998.

The effect of water stress is pointed out very well: in dry conditions, the dry matter production is lower by 30-50 % than in the irrigated treatments. In 1998, under irrigation, the total

biomass yield was 2431 g/m² - treatment N0; 3017 g/m²-treatment N150 and 3240 g/m²-treatment N300.

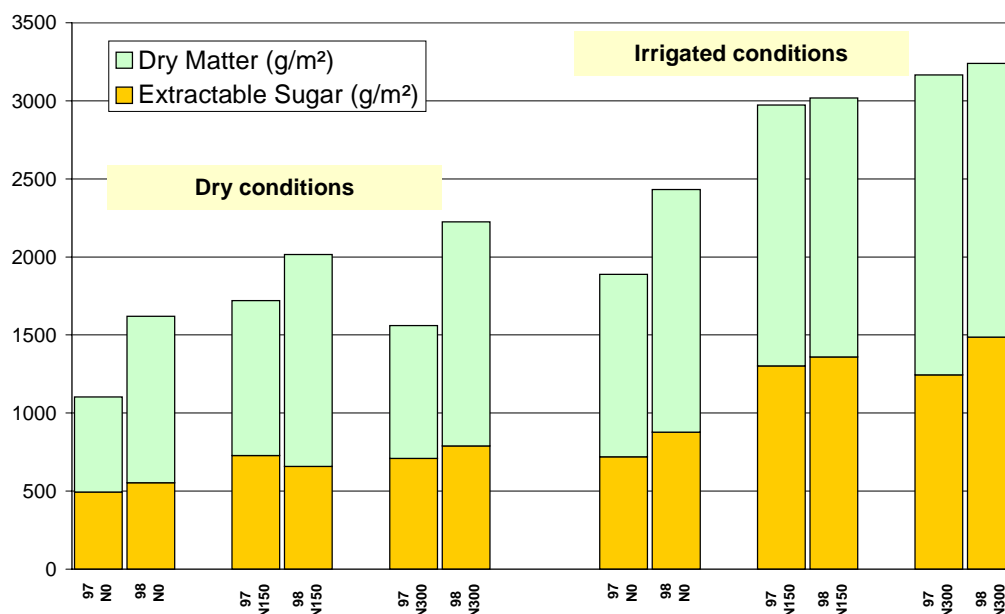

Figure 83: Dry Matter and extractable sugar

The dynamics of biomass accumulation during the vegetation period were 12 g/m²/day for treatment N0, 15 g/m²/day for treatment N150 and 16 g/m²/day for treatment N300.

Under stress water the biomass accumulation recorded 1619 g/m² for treatment N0, 2016 g/m² for treatment N150 and 2223 g/m² for treatment N300. The nitrogen factor determined an increase in dry matter as follows: 24 % for treatment N150 and 37 % for treatment N300.

As concerning the crop quality, the water and the nitrogen factors have an almost equal influence on the quantity of extractable sugar. As compared with the treatment N0 dry (water and nitrogen stress), the treatment N300 irrigated (water and nitrogen nonlimitant) presents an increase by 125 % in the quantity of extractable sugar (in the graphic, the extractable sugar is related to the quantity of dry matter).

The N doses in plants allow the characterisation of the nitrogen supply of the culture (dilution curve), related to a reference curve. The measurements of the total nitrogen content in plant were used for calculating the critical nitrogen (Nc), defined as the minimal quantity accumulated by plant, which allows the maximum increase in culture (Ulrich,1952). For the dilution curves, we used the following relation (Lemaire & Salette,1984):

$$Nc \% = a(DM)^{-b}$$

DM= dry matter accumulated during the vegetation period

For the reference curve we have used the Greenwood *et al.* (1990) generalisation for the C3 type plants (a=5.567 and b=0.5).

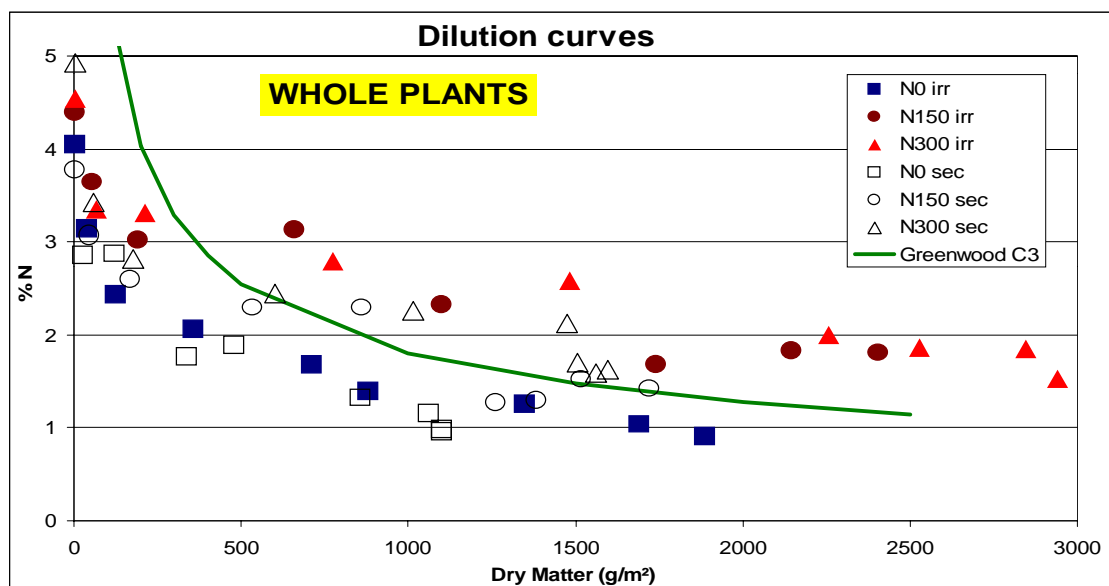

Figure 84: Dilution curves

In relation to the reference curve, we can analyse the degree of N supply in the culture. The values under the reference curve (Figure 84) show a striking nitrogen deficit; the points situated on the curve indicate a very well supplied culture, while those above the curve, excessive nitrogen. Also, the dilution curve allows the determination of N dynamics according to objectives (productivity, quality) the risk of environmental pollution, a better management of fertilization.

The experiments, carried out on sugar beet during 1997-1998, allowed a comparison of the effect of the limitant factors (water and nitrogen) related to the non limitant (potential) conditions, and there is a better understanding of culture evolution in these conditions.

Nevertheless, the main objective was to obtain constant reproducible results, in order to achieve modeling development of sugar beet culture.

6.5.5. CERES model calibration

The collaboration between INRA-Grignon and USAMV-Bucharest has begun for many years, especially through the Ph D thesis of Crivineanu (1996) about sugar beets in Bucharest. The same field, cultivar and practices were used during her thesis and this project, in order to benefit from her experience and knowledge about these conditions. During that collaboration, CERES model was used to simulate water and nitrogen transfers in the soil (Crivineanu & Leviel, 1996; 1997). The soil parameters determined for that purpose were used and adapted to the modifications done to the model since. This re-calibration was performed with the data of the 1997 experiments in Bucharest. Figure 85 shows the water contents in the first meter of soil in 1997, with and without irrigation. The model gave good results in both situations with that set of parameters.

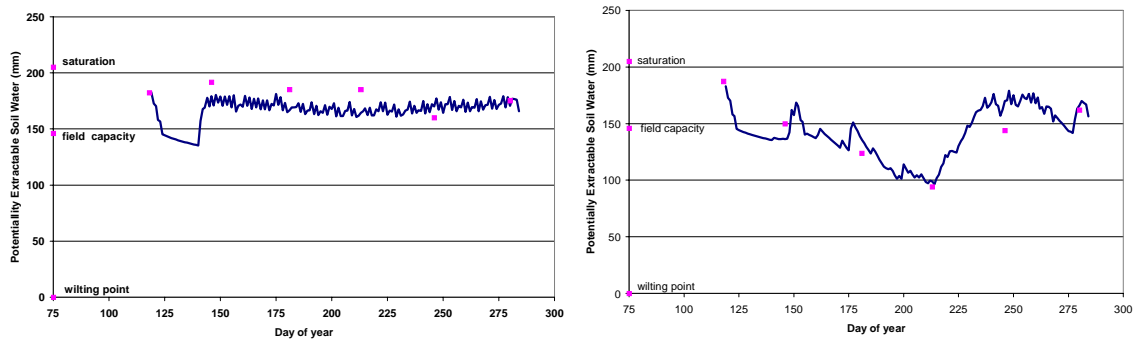

Figure 85 Simulated and observed Potentially Extractable Soil Water in the profile in 1997, with (left) and without (right) irrigation

6.5.6. Model validation

The experimentation in the field allowed us to follow the evolution of a sugar beet culture for various conditions of growth in order to have comparative data for the model.

The data resulting from experiments in 1998 were used for the validation of the model. In Figure 86 is presented the comparison between the two years (1997-1998). For the year 1997, the curve of simulation, for LAI and number of leaves followed experimental data (model calibration was carried out with the experimental data of this year). A difference for the period of senescence was identified, because the measurements were stopped at the end of August.

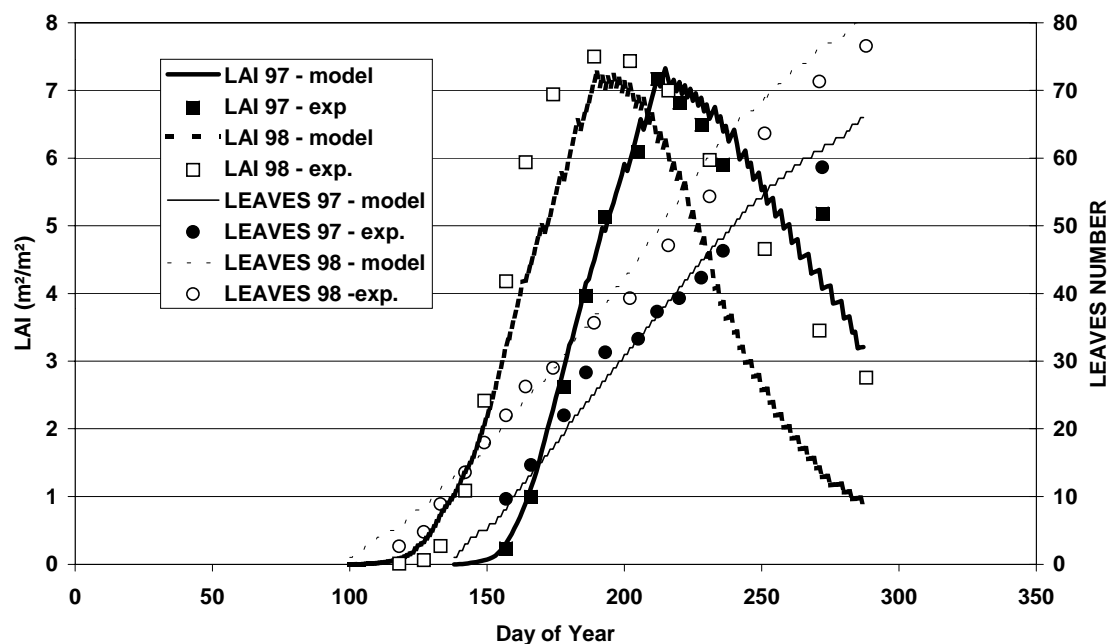

Figure 86 LAI and number of leaves experimental and simulated data for 1997 (calibration) and 1998 (validation)

In 1998, LAI is rather well simulated. The model seems to underestimate the increase in the leaf area which can be explained by an earlier sowing. For that reason sugar beet will be sown between these two dates of experimentation on the following simulations, i.e. 15th April. At

the beginning of simulation a little delay can be noticed and the maximum is not reached but the difference compared to the highest values did not exceed 4 %.

For the number of leaves we had good simulations for the two years of study, with a small over estimation at the beginning and at the end of vegetation in 1998.

Figure 87 shows the growth of total biomass for the two years analysed. The simulated total biomass fits well the experimental data for the final values, but dynamics is overestimated during the first half of the growing season. In 1998 the simulated final total biomass fits better the total biomass observed and dynamics is also better compared to the year 1997.

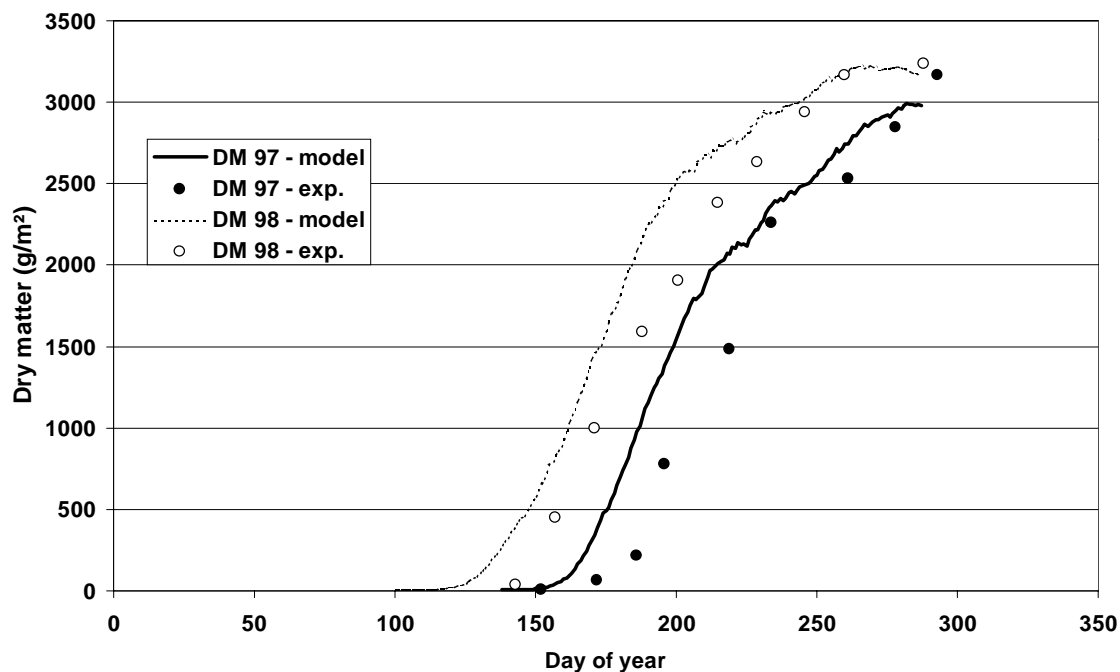

Figure 87 Dry matter experimental and simulated data for 1997 (calibration) and 1998 (validation)

This first validation of the model highlighted satisfactory behaviour of the " plant " module for the simulation of growth.

6.5.7. Utilisation for one crop and bare soil

For utilisation for one crop and bare soil, the file parameter (calibrated and validated) tested in the preceding paragraph was used. Among a 35-year long weather series (1963-1998), seven years were chosen, considered as representative. The years were classified by decreasing rainfall during two periods: crop growth (October-April) and intercropping (October-April). After each simulation the results of drainage (OWAT.DAT), nitrate leaching (ONIS.DAT) and total dry matter yield (OBIO.DAT), for these two periods were noted.

Figure 88 shows that the drainage is not influenced by rainfall during vegetation period.

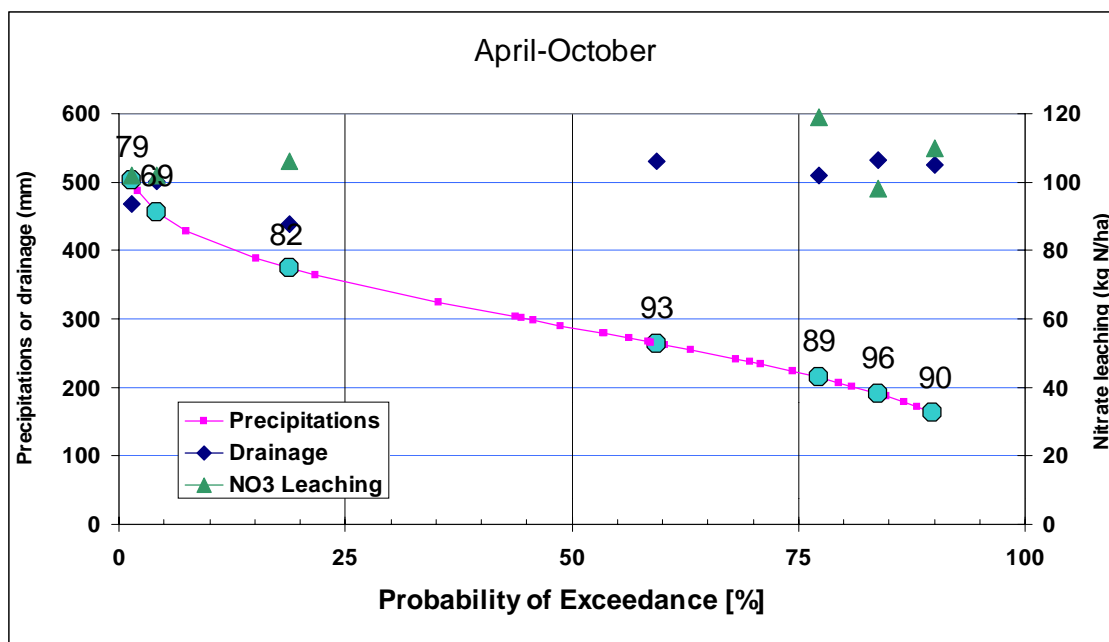

Figure 88 Model drainage and nitrate leaching in relation to probability of exceedance of rainfall totals for the vegetation period

This is the result of our simulations for which a high irrigation level was used. Water content was maintained high. A threshold of 180 mm was established for the irrigation (compared to the Field Capacity of 146 mm and Saturation of 205 mm). Each time the simulated water content reached that threshold, 20 mm of water was applied.

The risk of leaching is also significant because of several factors:

- Leaching is related to quantity of water drained
- Large amounts of mineral nitrogen fertiliser were applied in vegetation (300 kg N/ha)
- A part of the mineral fertiliser was applied at sowing (150 kg N/ha), with more risks to be washed than to be uptaken by the crop which has very slow starting at the beginning of growing period .

For the future scenarios to be tested, either it is necessary to reduce the amount of nitrogen fertiliser at sowing, or it could be removed. With regard to yield simulation in the potential conditions (water and nitrogen), no relation between the quantity of rainfall and the production of dry matter was observed (Table 11).

Figure 89 shows that the risk of drainage during the time of intercropping is weak and remains in correlation with the quantity of rainfall. It must be noted that simulation in this period was carried out without irrigation. There is no risk of NO₃ leaching because after harvest the soil is deprived out of nitrogen: it has been uptaken by the crop. In addition mineralisation is very weak in winter.

Year	Rainfall (mm)	Drainage (mm)	Leaching (kg N/ha)	Yield (DM) (t/ha)
1990	162	525	110	40
1996	191	532	98	34
1989	214	510	119	41
1993	264	530	123	36
1982	374	438	106	47
1969	456	502	102	43
1979	500	468	102	45

Table 11 Synthesis of simulation for the growth period

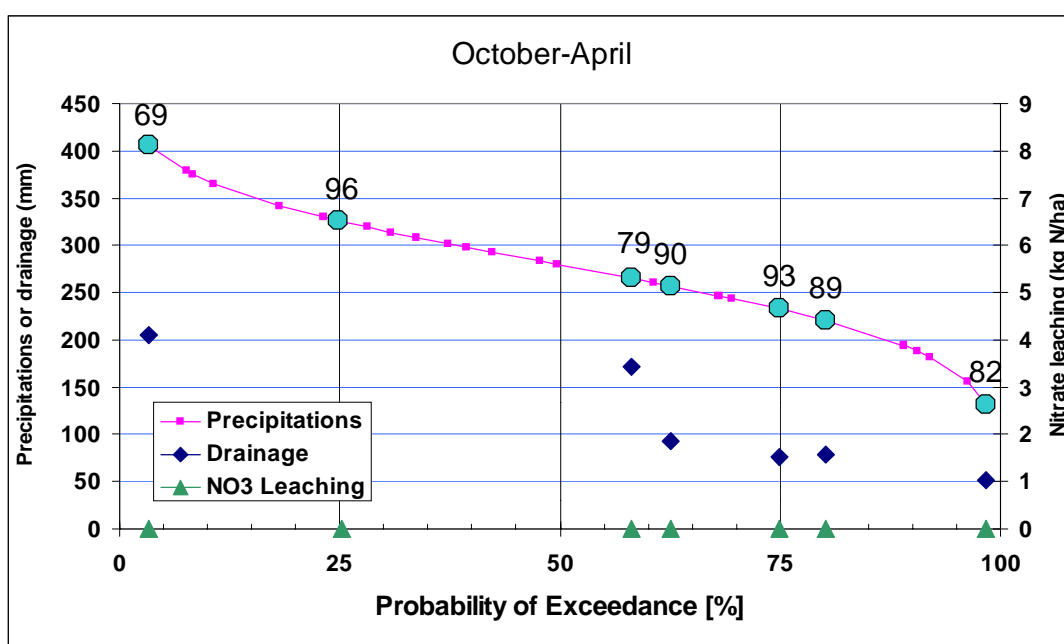

Figure 89 Modelled drainage and nitrate leaching in relation to probability of exceedance of rainfall totals for the intercropping period

To conclude, for the selected scenario (high nitrogen fertilisation and irrigation) the risks of drainage and leaching during crop growth are very strong, whatever the climate. Over the period of intercropping, the drainage remains weak and the risk of leaching is null. The results obtained show that the behaviour of the model is coherent.

6.6. Data Base

6.6.1. Description

All data of the project can be accessed through one access page (Figure 90). Hypertext links are used to browse the branchings of this Excel-based database.

COPERNICUS Data				
soil parameters		Maize	Wheat	Sugar Beet
Grignon	1998			suivi météo suivi dimensions de feuilles
Bucharest	1996			suivi météo, LAI et compartiments
	1997			suivi complet
	1998			suivi complet
Chelophechene	1997	suivi complet	suivi complet	
or Bojurishte	1998	suivi complet	suivi complet	
Fundulea	1997	suivi complet	suivi complet	
	1998	suivi complet	suivi complet	
Gembloux			suivi complet	

Figure 90: Access page to the COPERNICUS data branchings

Data are classified by crop, then location and year. One click is enough to navigate in the files, and the web capacities of Excel allow to go backward or forward as with an internet browser.

COPERNICUS Data												
Maize												
previous year's residues	Meteo	Soil				Crop						
		Soil Moisture	N analyses		Pest	pheno	crop density	LAI	Fresh Matter	Dry Matter	N content	Leaves
Grignon	1998											
Bucharest	1996											
	1997											
	1998											
Chelophechene	1997	Mt	ChMz97SM	NO3	NH4	pheno	ChMz97de	LA		DM	Nc	
	1997 lys.		ChMz97SMly	NO3	NH4	ph lys	ChMz97de	LA		DM	Nc	
	1998	Mt	ChMz98SM	NO3	NH4	ChMz98Pe	pheno	ChMz98de	LA	DM	Nc	
Fundulea	1997	Mt	SM	NO3	NH4	Pest	ph	de	LA	DM	Nc	
	1998	Mt	SM	NO3	NH4	Pest	ph	de	LA	DM	Nc	
Gembloux												

[back to index](#)

Figure 91: Maize branchings with hypertext access to data files

A click on Maize in Figure 90 opens Figure 91 and so on. In addition, file names are codified by series of two-letter abbreviations representing Location, Crop, Year, Data, respectively. For instance, **FuMz98DM** stands for dry matter of maize in Fundulea in 1998. Codifications keys are given in Table 12.

Place	Data
Bo Bojurishte	SD soil description
Bu Bucharest	Md pluri-annual meteo data
Ch Chelophechene	pc previous crop and residues' management
Fu Fundulea	Nt nitrogen analyses test
Gr Grignon	Mt meteo
	SM soil moisture dynamics
	ni Nitrate analyses dynamics
	nh Ammonium analyses dynamics
	Pe pesticides dynamics
	de density
	LA LAI dynamics
	FM Fresh matter dynamics by compartments
	DM Dry matter dynamics by compartments
	Nc %N dynamics by compartments
	Ld Leaves dimensions

Table 12: Data files codification

6.6.2. Perspectives

The short-term perspective is to generate a web database such as that described by Gosse *et al.* (1999). The Excel templates developed by INRA Grignon and used by all partners for data collection are designed to do so. An example is shown in Figure 92, as it can be seen at URL: <http://www-egc.grignon.inra.fr/ecobilan/Copernicus/base/data/if97.html>.

COPERNICUS Project 1997-1999 Data Base

INRA Grignon/USAMV Bucarest/MICEC Fundules/Fundulea Institute of Sofia
Copyright © 1999, INRA, all rights reserved.

Leaf Area Index Bucharest 1997 - means by treatment

Click here to go back to... [Complete French data structure](#) or [secondary menu](#).

Input

- **units:** m²/m²
- **methodology:** observation in the field
- **source:** USAMV Bucarest
- **correspondent:** C. Crivineanu



A graph of these data is available

		IS0 irrigated	IS150 irrigated	IS300 irrigated	NO dry	IS150 dry	IS300 dry
day 34	1/6/97	0.214	0.207	0.235	0.15	0.134	0.178
day 54	21/6/97	2.784	2.481	2.621	1.516	1.627	1.841
day 68	5/7/97	3.88	3.8	3.97	2.046	2.191	2.656
day 78	15/7/97	4.32	4.79	5.13	2.257	2.606	3.139
day 101	7/8/97	4.55	5.04	6.82	2.91	2.964	3.59
day 116	22/8/97	3.72	4.6	5.9	2.971	2.903	3.36
day 143	18/9/97	3.72	4.6	5.9	2.971	2.903	3.36
day 160	5/10/97	2.828	3.67	5.18	2.687	2.391	3.048
day 175	20/10/97	2.828	3.67	5.18	2.687	2.391	3.048

Click here to go back to... [Complete French data structure](#) or [secondary menu](#).

COPERNICUS Project 1997-1999 Data Base / INRA Bioclimatologie Grignon / leviel@hugpo.grignon.inra.fr
Copyright © 1999, INRA, all rights reserved.

INRA Bioclimatologie Grignon, 78850 Thiverval-Grignon, France

Another method of data distribution is possible

URL: <http://www.bioclima.grignon.inra.fr/accueil/Copernicus/LeafAreaIndex.html>

Figure 92: Extract of the COPERNICUS Project DataBase

7. Results of agricultural systems' typology

Danubian plain is located between latitude 43° and 45° North and surrounded by the Balkan Mountains in the South and by the Southern part of the Carpathian Mountains in the North.

7.1. Principle and objectives

Figure 93 introduces an overview of the analysis conducted to assess the influence of each farming system in the global nitrate loss in Danube plain. It shows how a collection of data about soils, climate and agricultural practices is essential in this task to identify and characterise main agricultural practices under pedo-climatic conditions of Romania and Bulgaria.

In this section we want to present the data collected in Romania and Bulgaria to perform an identification of soil and climate conditions as well as to characterise the current farming systems and practices in these countries. All these data will be useful to detect situations with risks of nitrate loss and to build some scenarios to test our hypothesis with models.

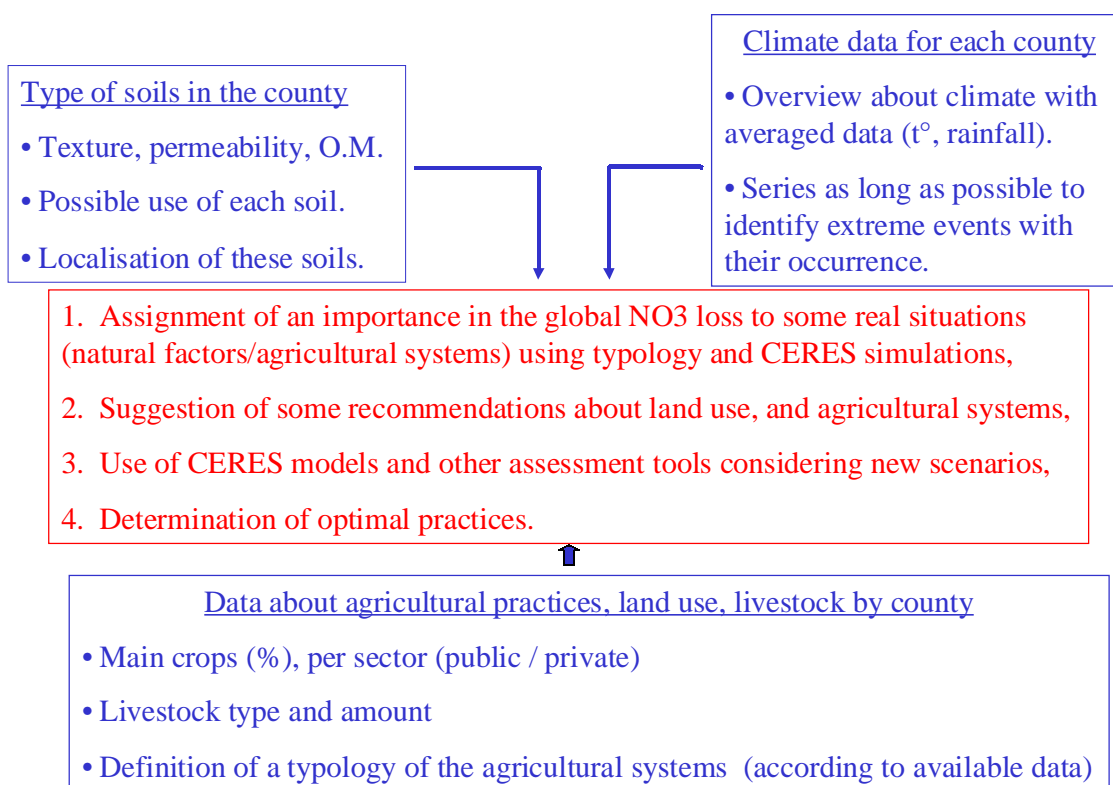

Figure 93 : Risks analysis for the current farming systems – diagram of reflexion

7.2. Situation in Romania

7.2.1. Zones studied

Romanian plain is surrounded by Danube in the South and by the Southern part of the Carpathian Mountains in the North. Considering counties close to Danube allow us to cover the most agricultural area of Romania. From North-east to West : GALATI, TULCEA, BRAILA, CONSTANTA, IALOMITA, CALARASI, ILFOV, GIURGIU, TELEORMAN, OLT, DOLJ (Figure 94).

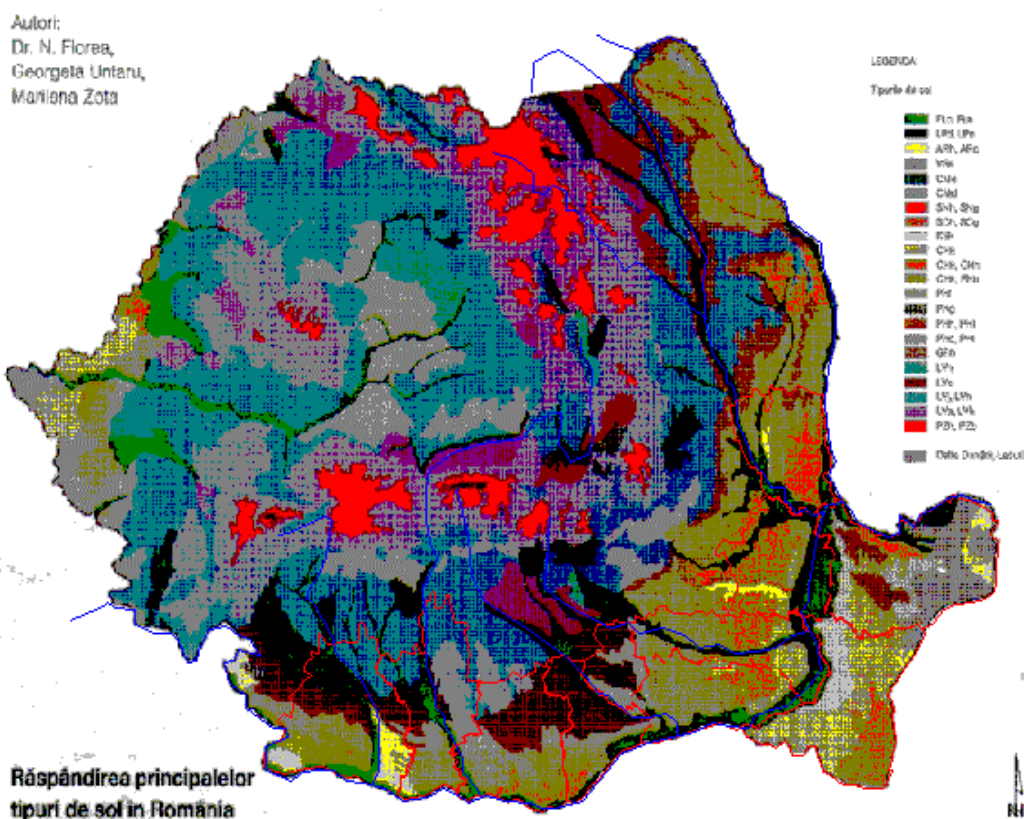

Figure 94 : Soil Map in Romania, main rivers and counties in Danube plain (better resolution in Appendix A).

7.2.2. Soils description

Most statistic data are available “on a county” basis. Consequently, soil as climate data must be collected for each of them. Following graph (Figure 95) presents the major soils in Romania and Figure 96 shows major soil types with respective percentage by county.

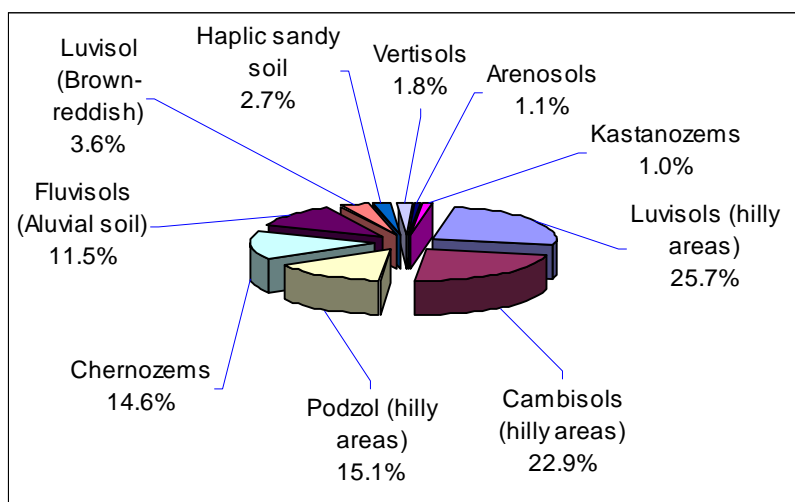

Figure 95 : Major soils in Romania (>200 millions ha)

GALATI	Chernozems	80%
	Arenosol, sandy soil	10%
	Fluvisol (Aluvial soil)	10%
BRAILA	Chernozems	65%
	Fluvisol (Aluvial soil)	30%
	Arenosol	5%
TULCEA	Danube Delta	35%
	Chernozems	20%
	Arenosol, sandy soil	20%
	Fluvisol (Aluvial soil)	10%
	Kastanozems	15%
CONSTANTA	Chernozems	70%
	Kastanozems	20%
	Fluvisol (Aluvial soil)	5%
	Danube Delta	3%
	Arenosol	2%
IALOMITA	Chernozems	80%
	Fluvisol (Aluvial soil)	20%
CALARASI	Chernozems	90%
	Fluvisol (Aluvial soil)	10%
ILFOV	Luvisol (Brown-reddish soil)	45%
	Chernozems	40%
	Fluvisol (Aluvial soil)	5%
	Bucharest area	10%
GIURGIU	Luvisol (Brown-reddish soil)	45%
	Chernozems	40%
	Fluvisol (Aluvial soil)	15%
TELEORMAN	Chernozems	55%
	Luvisol (Brown-reddish soil)	30%
	Vertisol	10%
	Fluvisol (Aluvial soil)	5%
OLT	Chernozems	35%
	Luvisol (Brown-reddish soil)	25%
	Vertisol	20%
	Fluvisol (Aluvial soil)	15%
	Arenosol	5%
DOLJ	Luvisol (Brown-reddish soil)	35%
	Chernozems	30%
	Arenosol	25%
	Fluvisol (Aluvial soil)	5%
	Cambisol	5%

Figure 96 : Major soils of Romanian Danube watershed (% are estimation)

7.2.2.1. General characteristics of major soils in Danube plain

VERTISOLS (FAO) :

Soils having, after the upper 18 cm have been mixed, 30 % or more clay in all horizons to a depth of at least 50 cm. Alternate swelling and shrinking of the expanding clay produces deep cracks during the dry season, in most years they are at least 1 cm wide to a depth of 50 cm (Driessen & Dudal, 1991). Fine texture and poor internal drainage account for the often poor workability of Vertisols, both in wet and dry conditions. They are productive soils if properly managed.

Dry (cracked) Vertisols with a surface mulch have a high initial infiltration rate. However, once the surface soil is thoroughly wetted and the soil has swollen and the cracks closed, further infiltration is almost nil. The process of swell/shrink implies a discontinuous pore system. They are considered soils with a relatively good water holding capacity. Most Vertisols have a high CEC and a high base saturation, pH values are in the range 6 to 8.

Large areas of Vertisols are used only for rough grazing, wood chopping. Areas that are in use for rainfed and irrigated agriculture are evidence that these soils form a considerable

agricultural potential but special management practices are required to secure sustained production (Dudal, 1965).

FLUVISOLS (FAO) :

Young alluvial soils which show stratification or other evidence of recent sedimentation. A C – profiles, Ah-horizon may be present. Evidence of stratification and no or only a weak soil structure. Gleying is common in the lowest part of the profile.

Texture of Fluvisols can vary from coarse sand in levee soils to heavy clays in backswamps. Most Fluvisols show mottling due to alternating reducing and oxidizing conditions. Many clayed Fluvisols have few pores and a low hydraulic conductivity. Fluvisols on river levees and coastal sand ridges are porous as well (Driessen & Dudal, 1991). Moreover, many of coastal landforms were once colonised by a pallustric vegetation which left large tubular pore in the sediment that are often still intact.

Most Fluvisols are fertile soils, they have neutral or near-neutral pH values which do not impair the availability of nutrients. Fluvisols are used for a wide range of crops, or for grazing. Flood control, drainage and/or irrigation are normally required.

CHERNOZEMS (FAO) :

Soils having a mollic¹ A-horizon to a depth of at least 15 cm ; having a calcic² horizon or a petrocalcic³ horizon and/or concentrations of soft powdery lime within 125 cm of the surface (Driessen & Dudal, 1991). They appear as black soils rich in organic matter and come mostly from loess.

Chernozems possess favourable physical properties. Their total pore volume lies normally between 55 and 60 % in the Ah-horizon and between 45 and 55 % in the C-horizon. The soils have a high moisture holding capacity (water content of 33 % at field capacity and 13 % at permanent wilting point suggest that available moisture can amount to 20 volume %). Chernozems surface soils contain 5 to 15 % mild humus with a high proportion of humic acids and a C/N ratio around 10.

The high natural fertility of Chernozems and their favourable topography allow a wide range of agricultural uses including arable cropping and cattle ranging. Summer drought makes moisture conservation imperative. Preservation of the favourable structure through timely cultivation and careful irrigation prevents ablation and erosion.

KASTANOZEMS (FAO)

Soils having a mollic A-horizon to a depth of at least 15 cm; having one or more of the following: (petro)calcic or (petro)gypsic⁴ horizon or concentrations of soft powdery lime within 125 cm of the surface (Driessen & Dudal, 1991). They appear as dark brown soils rich in organic matter.

Kastanozems have an intermittent water regime. In the dry period, the soils dry out to great depth. In wet period, the soils are often incompletely moistened, partly because of the low total precipitation sum and partly because the non-capillary porosity of Kastanozems is often rather low so that surface run-off during and after a heavy shower can be considerable. Their physical properties are less favourable than those of Chernozems but otherwise comparable. The lower humus content of the surface layer is associated with a lower degree of micro aggregation, which manifests itself in a lower total pore volume (40-55 %), a lower moisture storage capacity, a denser packing of the soil and a lower permeability to water.

¹ mollic : surface horizon with dark colour due to organic matter ; base saturation > 50 % ; ...

² calcic : distinct calcium carbonate enrichment

³ petrocalcic : continuous cemented or indured calcic horizon

⁴ petrogypsic : distinct calcium sulfate enrichment, cemented with gypsum

Many Kastanozem areas are used for extensive grazing. The principle arable land use is the production of small grains and (irrigated) food and vegetable crops. Drought and erosion are serious limitations.

LUVISOLS (FAO)

Base rich soils with a distinct clay accumulation horizon (argic⁵ B-horizon). Luvisols have a brown to dark brown A-horizon over a brown to strong brown or red Bt-horizon (Driessen & Dudal, 1991).

Most Luvisols are well drained but shallow groundwater may induce gleyic soil properties in and below the Bt-horizon in depressions areas. They have favourable physical properties, they have granular or crumb surface layers that are porous and well aerated. The available moisture storage capacity is around 15 to 20 volume percent. Luvisols with a high silt content may be sensitive to slaking and erosion. The surface soils contain a few percent organic matter with a C/N ratio of 10 to 15.

Because of their moderate stage of watering and high base saturation, Luvisols with a good drainage status are suitable for a wide range of agricultural uses. Structure deterioration may occur if Luvisols with a high silt content are tilled in wet condition or with heavy machinery. In the temperate zone, they are widely grown to small grain, sugar beet, fodder, ... and in sloping land, they are used for orchards and grazing.

ARENOSOLS

Soils which are coarser than sandy loam to a depth of at least 100 cm of the surface, having less than 35 % of coarse fragments in all horizons within 100 cm from the surface. Arenosols in the temperate zone show signs of more advanced soil formation than those in arid regions. They occur predominantly in fluvio-glacial, alluvial, lacustrine, marine or eolian quartzitic sands (Driessen & Dudal, 1991).

Arenosols are very permeable soils; their saturated hydraulic conductivity varies with packing density of the sand and have any value between 300 and 30 000 cm/day. They store only between 5 and 12 % available water. They need irrigation but many of them are unfit for surface irrigation due to high percolation losses. Total pore fractions vary between some 0.35 and 0.55 cm³/cm³. The A-horizon is shallow and contain only a few percent organic matter or less.

Arenosols in the temperate zone are moderately suitable for mixed arable cropping and grazing, supplemental irrigation is needed during dry spells.

PODZOLS (podzolisation)

A lot of soil showing a tendency to podzolisation are present in Romanian plain. Therefore it's interesting to analyse the characteristics of this particular soil type. As described by Driessen & Dudal (1991), Podzols are soils with a subsurface horizon that has the appearance of ash due to strong bleaching by aggressive organic acids.

Podzolisation is a succession of processes, including :

- cheluviation, the movement of solute metal-humus complexes (chelates) out of the surface layer(s) to greater depth, and
- chilluviation, the subsequent accumulation of Al- and Fe-chelates in a B-horizon.

The clay content is normally low or very low (≤ 10 %). The sandy texture facilitates tillage. Most Podzols formed under conditions of free movement of water through the upper and middle portions of the soil. Where the illuviation horizon is dense, or an indurated layer has

⁵ argic : subsurface horizon which has a distinctly higher clay content than the overlying horizon

formed, water movement through the subsoil may be impaired. Their low water holding capacity may cause drought stress in dry periods. The C/N ratio has a characteristic pattern with values of 20 to 50 in the surface horizon, decreasing to 10 to 15 in the bleached horizon. Decomposition of organic matter and surface soil homogenisation are slow and are mainly done by fungi, small arthropods and insects.

Severe acidity, low chemical fertility and unfavourable physical properties make most Podzols unsuitable for arable cropping. They have some potential for forestry and extensive grazing.

7.2.2.2. Soil data about main soil types

Romanian team from University of Bucharest provided data corresponding to the major soil types found in Romanian plain. They could be considered as representative characteristics for these soil types (see appendix B).

After a first global risk analysis considering characteristics of main soils, a general survey about climate (temperature and precipitation) and a synthesis about main crops and animal for every county of the Danube plain, these data could be useful to build some scenarios suitable for simulation with CERES models.

7.2.3. Meteorological data

A lot of climate data corresponding to some stations in the Danube plain and a lot of years are available. Unfortunately a large part of them presents some gaps. Nevertheless it has been decided to work with available averaged data to draw an overview of climate (rainfall) in different parts of the Romanian plain.

In the context of a leaching risk, it is particularly essential to analyse occurrence of extreme events regarding rainfall. Consequently, a frequential analysis must be conducted for each county. Romanian team from Fundulea Institute provided climate data (appendix C). Because long series of complete data aren't available (except for Calarasi county) the frequential analysis conducted must be considered carefully (4 or 5 years of data can't form an excellent overview of climate). Consequently, each frequential analysis presented in appendix D doesn't recover the same worth and must be considered separately.

Figure 97 presents occurrence of rainfall events and averaged monthly sums of rainfall for Caracal station (OLT) as an example. In this case, April, May and June seem to be the more rainy months. The sum of rainfall for these months is at least equal to 60 mm with a frequency of more 50 %. To avoid drainage, this amount of water must be evapotranspired or stocked in soil. Analysis of soil characteristics, crop development stage and potential amount of nitrate in soil will help to predict a possible risk of leaching. Another critical period will probably correspond to November and December (at least equal to 50 mm with a frequency of 50 %) when a large part of arable land is under bare soil.

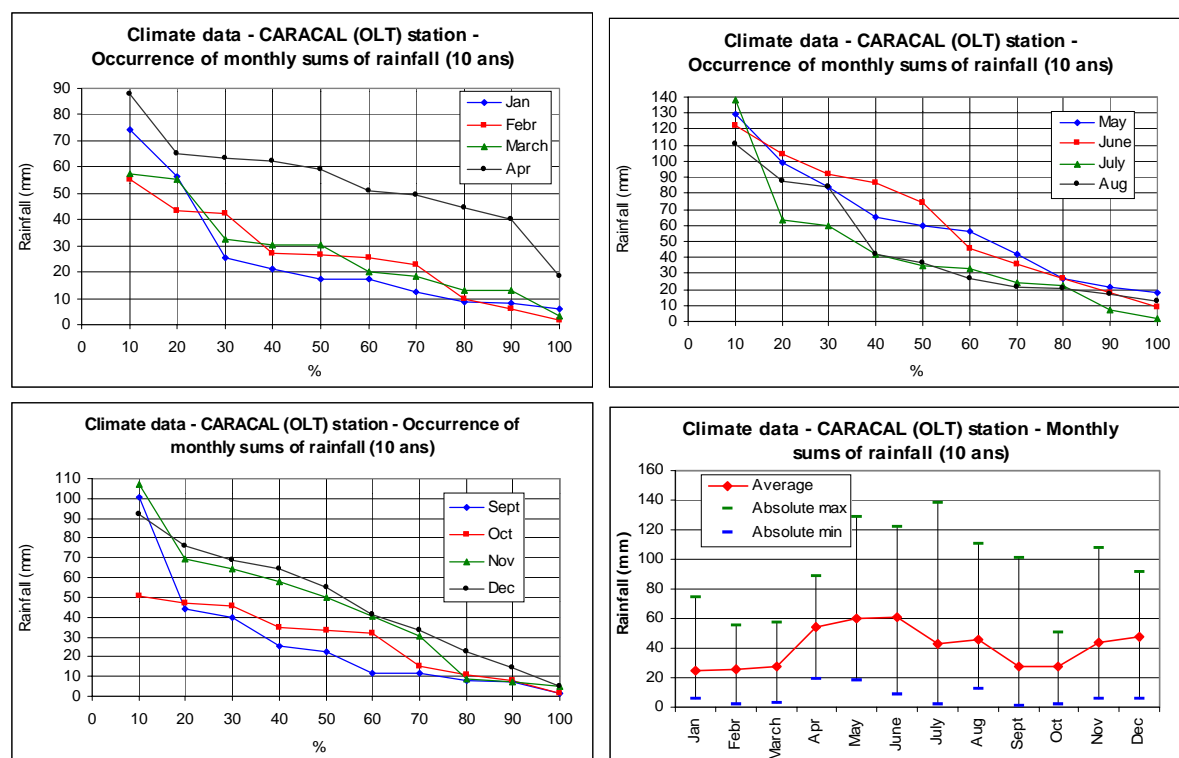

Figure 97 : Occurrence of rainfall events and averaged monthly sums of rainfall for Caracal station (OLT)

7.2.4. Farming systems and practices

Like some other East countries Romania started a large land privatisation program some year ago. Consequently this country is characterised by an excessive land fragmentation. Different kinds of information are available to characterise the Romanian agricultural practices. Statistical data about repartition of cultivated area and major crops exists for each county. Moreover the Romanian team of University of Bucharest conducted a large survey in our study area (127 farms managing 88 500 ha) to establish a typology of the farms. This realised by Bausson and Tison (1994) about farm typology in CALARASI county was useful as well. Finally knowledge of Romanian teams has been essential to identify current agricultural practices crop by crop and during a rotation.

7.2.4.1. Major crops and animals by county

As in section about climate data, the analysis of national statistical data (Comisia Nationala de Statistica, 1998) is presented here with the results corresponding to OLT county, complete results can be found in appendix E. Major crops can be identified for public and private sector (Figure 98), heads of the different types of animals per hectare of cultivated area is useful to have an idea of livestock pressure on environment. The combination of these data with a typology of different types of farms would be essential to obtain a more precise overview of farming systems in Romania.

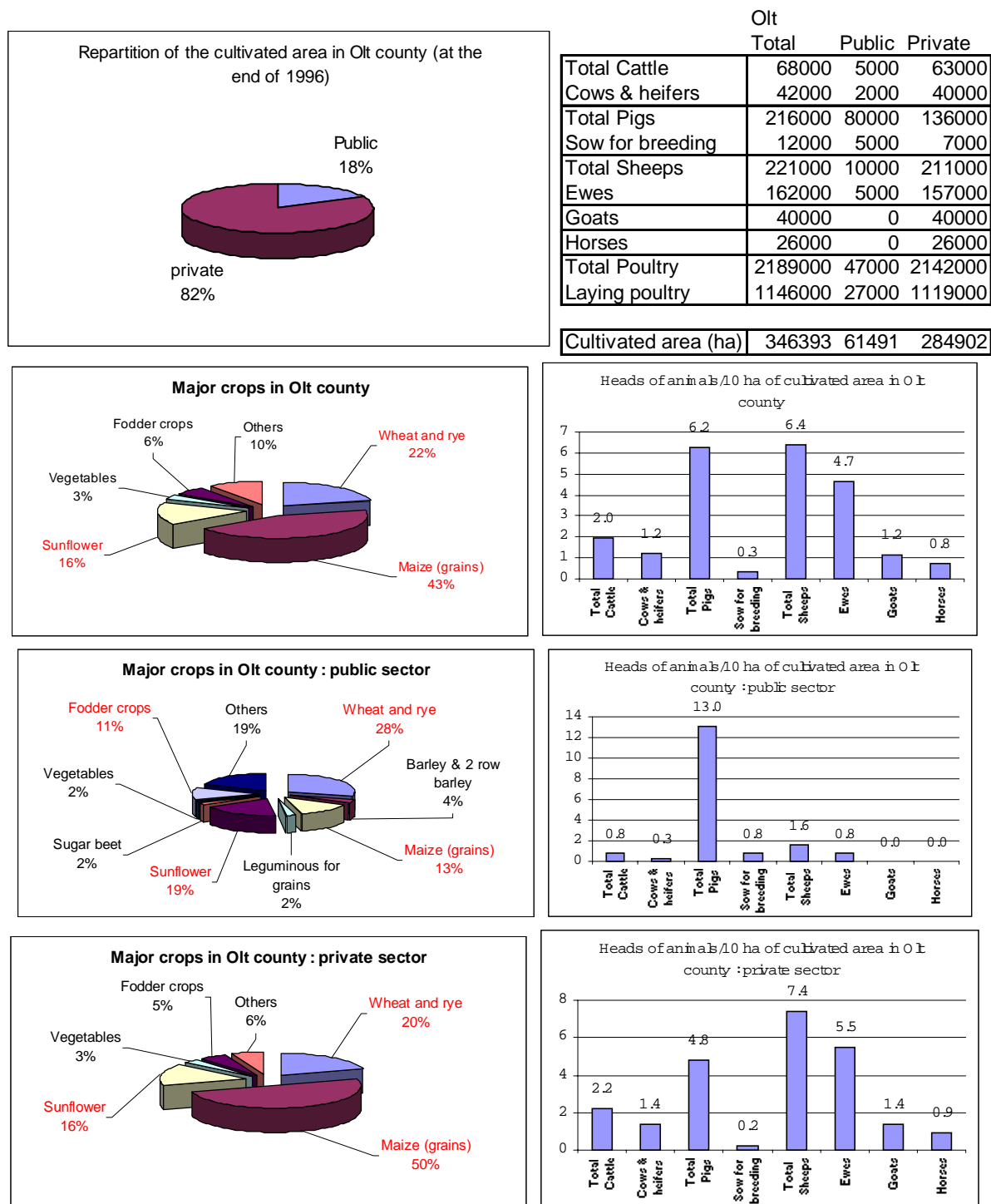

Figure 98 : Analysis of national statistical data : major crops and animals for OLT county

7.2.4.2. Typology of farms, farming systems

Following data collected on the French foreign trade Internet site, agricultural area is actually distributed between three types of structure :

- 3.7 millions of small individual farms with an averaged size of 2.3 ha, owning 59 % of agricultural area,
- agricultural associations with an averaged size closed to 450 ha for societies and 100 ha for family associations, owning 22 % of agricultural area,

- trading societies non-privatised with an averaged size of 2000 ha and owning 19 % of agricultural lands.

More precisely, farms in Romania can be subdivided into mixed farms with animal husbandry and crops and farms with crops only (animal husbandry is found only in farms with an agricultural area <10 ha or >100 ha). The first category could be called type E and the second one type C. Farms from type E can be classified following structure presented by Figure 99.

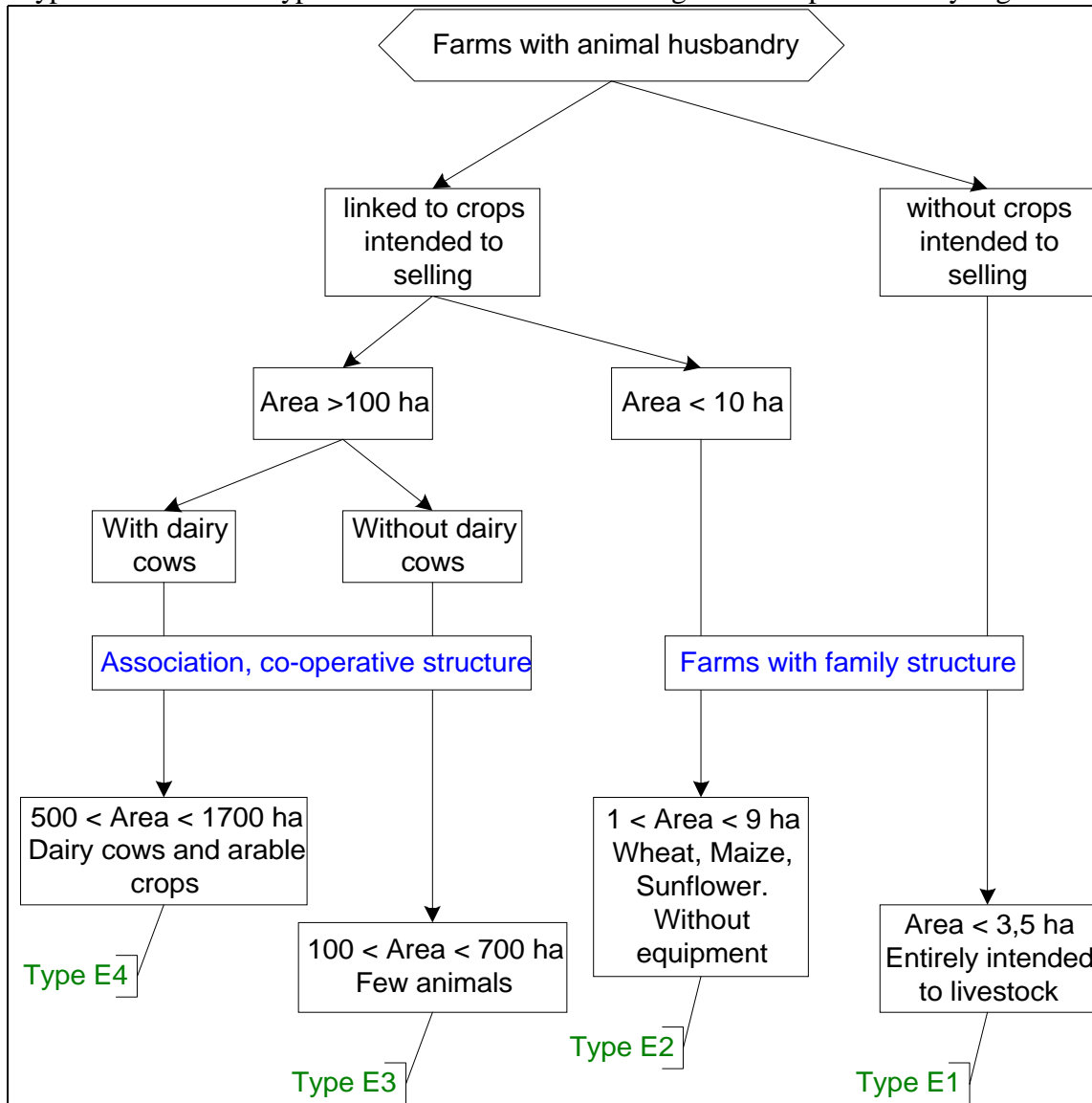

Figure 99 : Typology of farms with animals

Farms without livestock (type C) are subdivided in five categories with the following characteristics (the classification is summarised in Figure 100 :

C1 : family farms with extensive farming system. Rotation of crops is simple with two crops intended to auto-consumption (wheat or maize) and established on a single plot. In this type, agricultural practices are simplified (no fertilisers, no pesticides) and mechanical work is carried out by enterprise. Finally 11 % of the agricultural area is cropped with vegetable. In this case chemical and organic fertilisers are applied, often without reasoning about crop's needs.

C2 : farms with agricultural area between 30 – 100 ha. Some families (\pm 10 members) are gathered in an association with a logistic director. Main crops rotation is sunflower-wheat-wheat-maize-maize-sunflower and agricultural works are carried out by members. Consequently agricultural practices are simple and often realised manually. Fertilisers application as well as treatment with pesticides are at the very least. Plots are scattered and irrigation non-existent.

C3 : associations (70 to 200 members) without legal personality and with agricultural area contained between 100 – 300 ha. Main agricultural practices are realised by extern firms and small works by members on their plots (more individualist than in C2). High amount of fertilisers are applied mainly on wheat and treatments are regular. Yields are better.

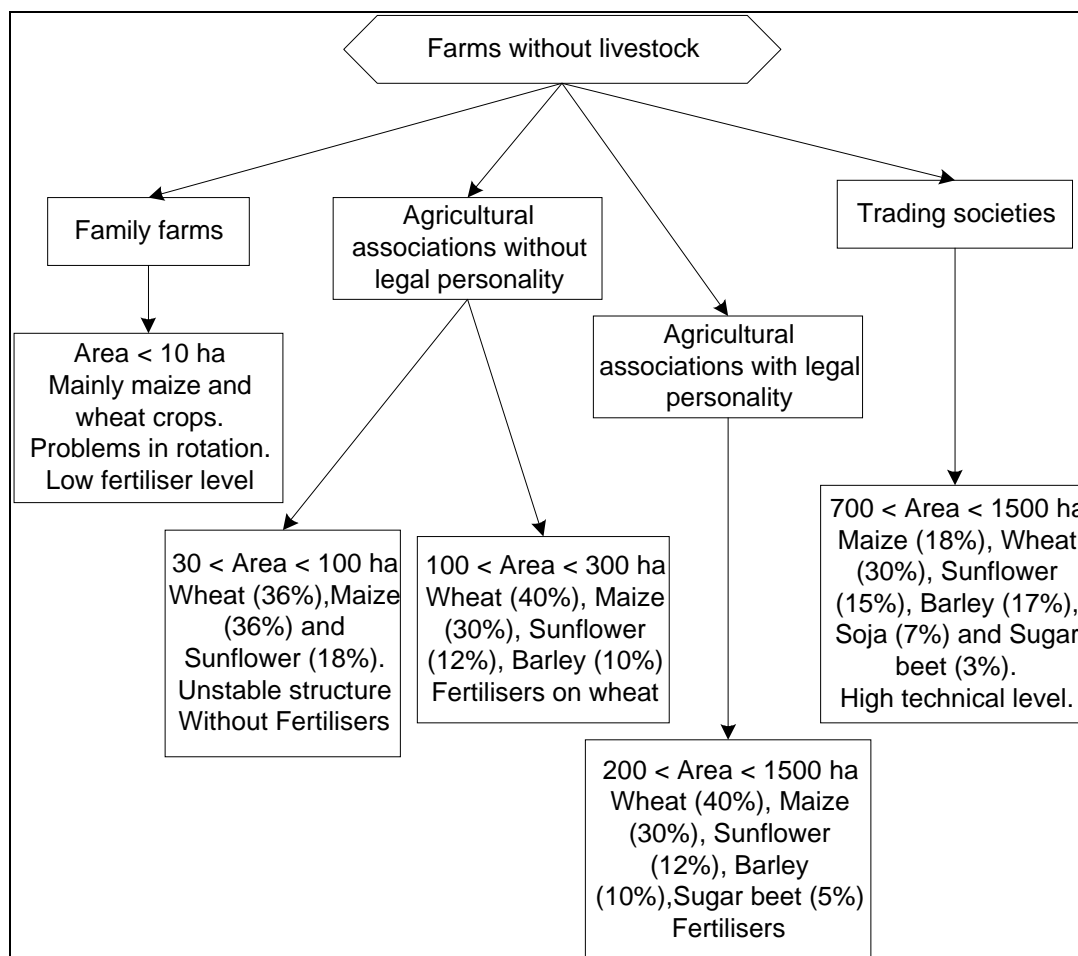

Figure 100 : Typology of farms without livestock

C4 : associations with legal personality and area contained between 200 and 1500 ha. Plots come directly from old public co-operatives and are grouped around farm buildings. Main crops are identical to C3 but sugar beet is include in rotation. High amount of fertilisers are applied on crops.

C5 : farms with agricultural area contained between 700 – 1500 ha are trading societies. Large area and high funds allow modern agricultural practices and thoughtful rotation of crops. Members are mainly urban people and workers are salaried and concerned by final results. High amount of fertilisers can be applied

but are conducted following soil sample. Finally treatments of crops are realised following advice of engineers.

7.2.4.3. Current rotations of crops in Romania

Advice from Romanian teams can help to identify agricultural practices for each major crop. Some types of rotations of crops are present in Romanian plain : winter-wheat monoculture, maize monoculture and a some variants including wheat, sugar beet, maize and sunflower. Sugar beet is mainly cropped in big associations. Due to risk of diseases, sunflower can only be cropped on the same plot with at least 3 or 4 years of interval (Soltner, 1999), therefore another current rotation is sunflower-wheat-wheat-maize-maize-sunflower.

The schedule of crop and inter-crop practices will allow us to detect (in parallel with climate and soil data) which period of the year is liable to present a leaching risk (following figures). Nitrogen fertilisation is currently realised by spreading of NH_4NO_3 , urea or complex fertiliser. These crop practices are scheduled to assure a respectable yield but stay probably an ideal for small structures of production.

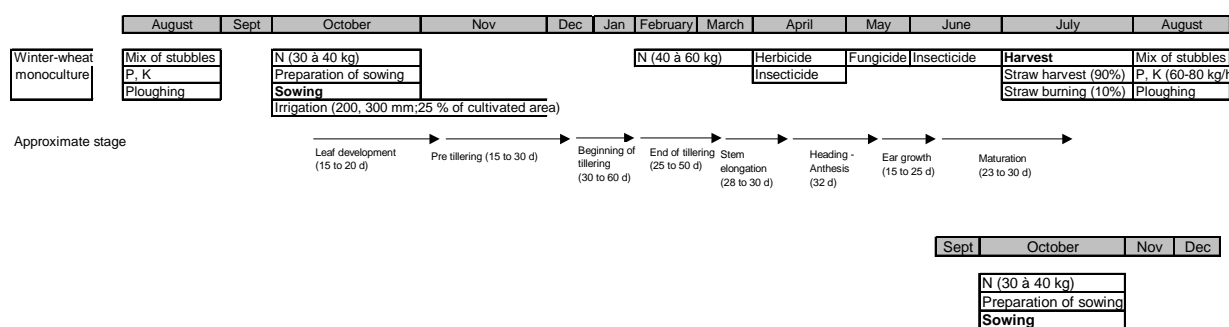

Figure 101 : Current agricultural practices for Winter-wheat monoculture

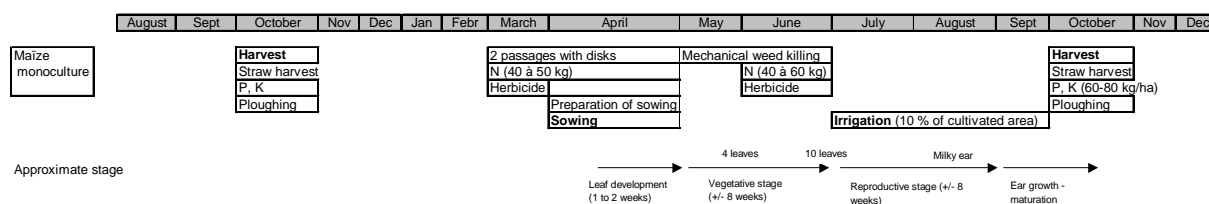

Figure 102 : Current agricultural practices for Maize monoculture

Preliminary analysis of these crop successions and practices shows that except for winter wheat (and barley) most of the crops are spring crops. It means that soil stay, on a significant part of agricultural area, uncovered during winter. Sowing of a nitrate catch crop or another covering crop is indeed rare for lack of time on favourable climatic conditions.

With regard to wheat crop it seems that nitrate application is usually split into two fractions. Unfortunately first fertilisation is conducted when capacity of nitrate catching is quite low (before sowing). On another hand the organic matter management, which is probably different following the structure of farm, must insure a reasonable organic matter level in soil. Tools for this task stay in crops residues and organic manure management.

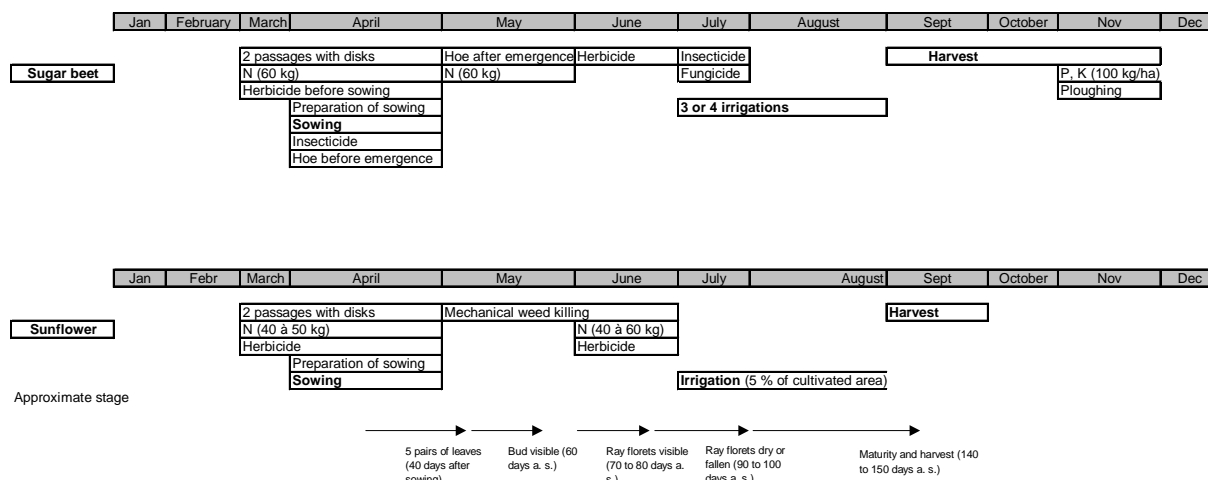

Figure 103 : Current agricultural practices for Sugar beet and Sunflower rotation

7.3. Situation in Bulgaria

7.3.1. Zones studied

Bulgarian plain is surrounded by Danube in the North and by Balkan mountains in the South, the Danube watershed in Bulgaria has a total area equal to 4 640 000 ha. Considering regions closed to PLEVEN climate station (LOVECH county) and OBRASTZOV CHIFLIK (next to RUSE city, RUSE county) will allow us to work with climate data and soil types characteristic of the Danube plain (Figure 104).

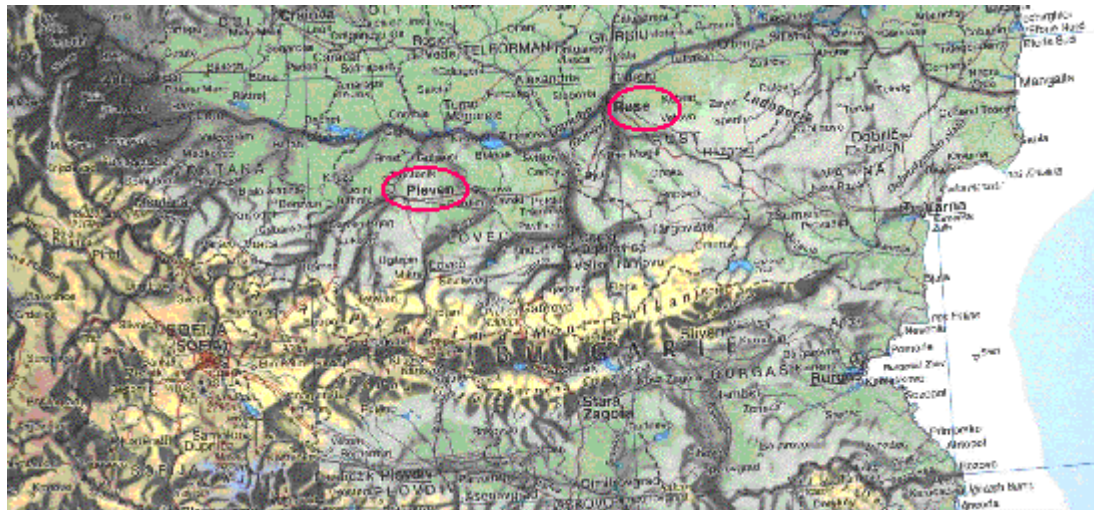

Figure 104 : Danube plain in Bulgaria, location of PLEVEN and OBRASTZOV CHIFLIK stations (better resolution in Appendix A)

7.3.2. Soils description

Figure 105 shows different types of soils present in Bulgarian Danube watershed. Soil characteristics given below correspond to “The soils of Bulgaria” Monograph and the diagnostics of the Bulgarian soils by Penkov *et al.* (1992).

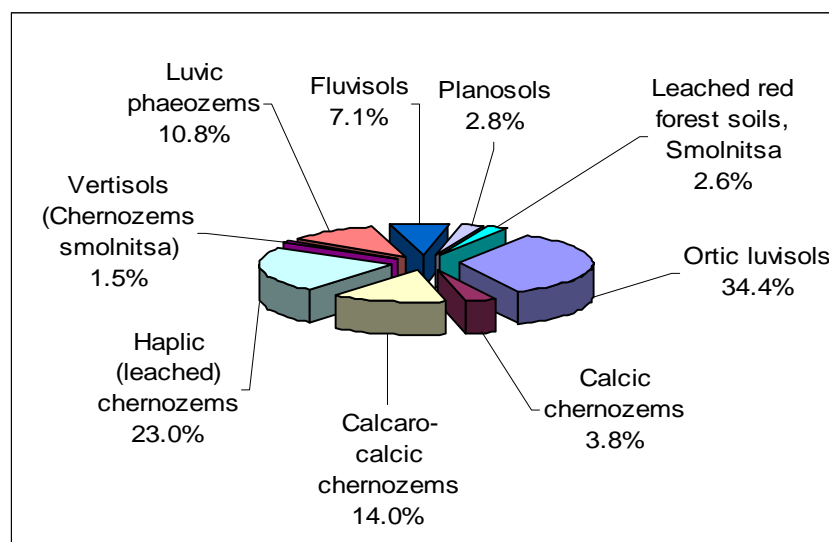

Figure 105 : Soil types in Bulgarian Danube watershed (FAO classification)

7.3.2.1. General characteristics of main soils in Danube plain

Main soils in the Bulgarian Danube plain are described by Penkov *et al.* (1992) :

Ortic luvisols cover a large part of the Danube watershed, they are heavy loams based on red clay in B-horizon and loams in A-horizon. Water retention is characterised by a Field Capacity close to 30 % by weight and conductivity at saturation ranges from 17 to 34 cm/day. Ortic luvisols are moderately permeable.

Calcaro-calcic chernozems are spread along Danube. Their texture is loamy (sandy to silty loams). Field Capacity is between 23 and 27 % by weight while conductivity at saturation is from 173 to 518 cm/day. Their high permeability and porosity cause topsoil drying up to wilting point in summer. Going to the South, soil texture is getting heavier and soil profile less permeable.

Haplic chernozems are heavy loams based on black-brown clay. They are less permeable than previous chernozems (conductivity at saturation is from 8.6 to 34.6 cm/day) and Field Capacity ranges from 28 to 30 % by weight.

Vertisols texture is extremely heavy and corresponds to clay soil. This soil is the least permeable in Danube plain (conductivity at saturation around 1 cm/day). Field Capacity is around 40 % by weight.

Planosols are also extremely impermeable because conductivity at saturation doesn't exceed 8 cm/day. Vertisols and Planosols are prone to swelling and water logging in spring and early summer.

7.3.2.2. Data about main soils around PLEVEN and OBRASTZOV CHIFLIK

Some results coming from old soil analysis realised (around PLEVEN) in TRASTENIK (calcaro-calcic chernozem), DABNIK (haplic chernozem) and NIKOLAEVO (ortic luvisol) are available (appendix F). As noted previously these data would be useful to build scenarios corresponding to some current “climate – soil – farming systems” situations. Some parameters necessary for use of CERES models will be estimated on the basis of well-known parameters. Haplic chernozem is the main soil in OBRASTZOV CHIFLIK country side. Moreover, some fluvisols are present along rivers. Iskâr, Vit, Osâm and Yantra rivers flow in PLEVEN area and soils along Danube can also be studied with PLEVEN and OBRASTZOV CHIFLIK climate. Fluvisol are young alluvial soils with sandy texture, characteristics are mentioned in Chapter II.

7.3.3. Meteorological data

Our objective is the assessment of a leaching risk. Consequently it's important to have an overview of the characteristics of climate (Figure 106, Figure 108) and essential to carry out a frequential analysis of rainfall to analyse occurrence of extreme events. Following this methodology, twenty years (1961 to 1980) of climate data available for PLEVEN and OBRASTZOV stations are synthesised by Figure 107 and Figure 109.

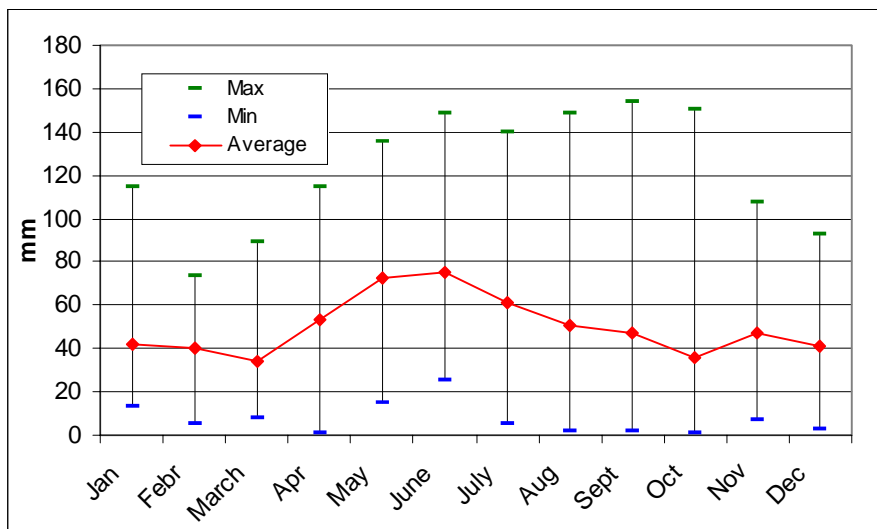

Figure 106 : Average, absolute maximum and minimum of rainfall calculated on a 20 years period for PLEVEN station

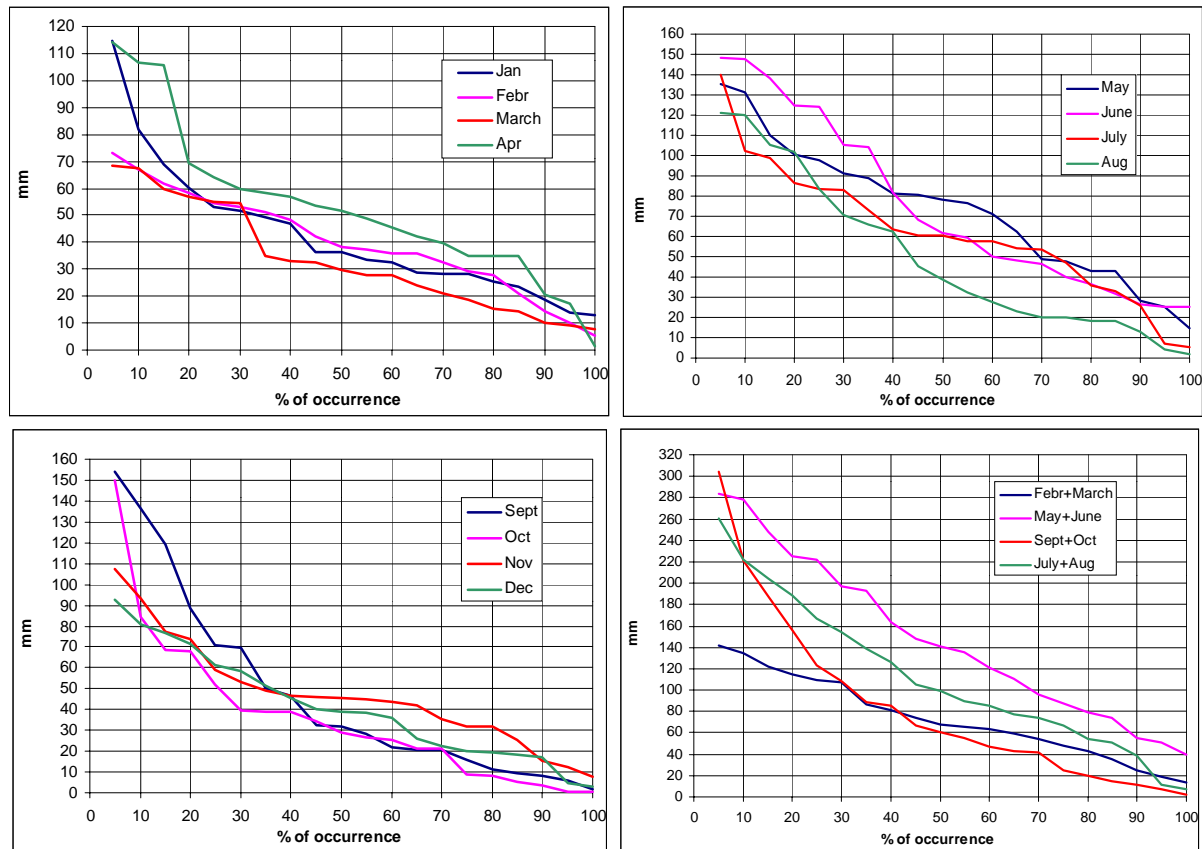

Figure 107 : Occurrence of rainfall events (by month and for 2 consecutive months) for PLEVEN station

As in Romania May and June are the most rainy months with an average higher than 60 mm of cumulated rainfall. More precisely, cumulated precipitation in June are higher than 100 mm during 35 % of time. Finally it's obvious that high amount of rain can occur during autumn months, when the soils can stay uncovered.

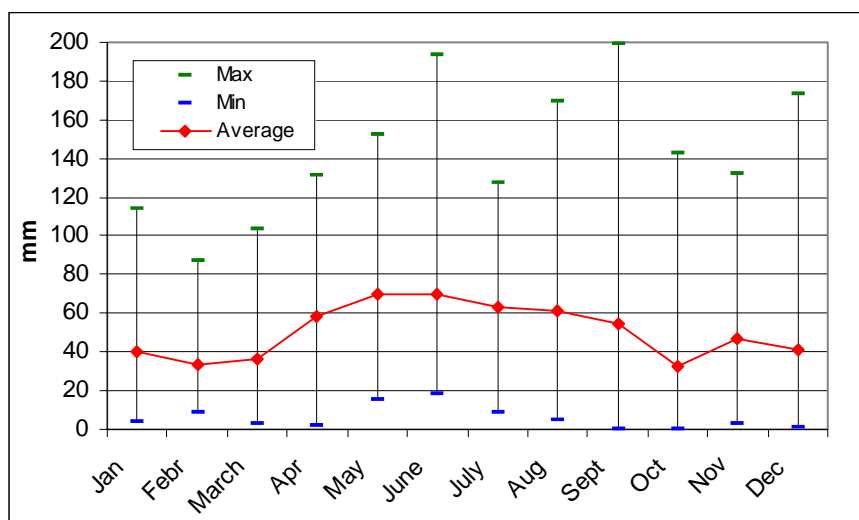

Figure 108 : Average, absolute maximum and minimum of rainfall calculated on a 20 years period for OBRASTZOV CHIFLIK station

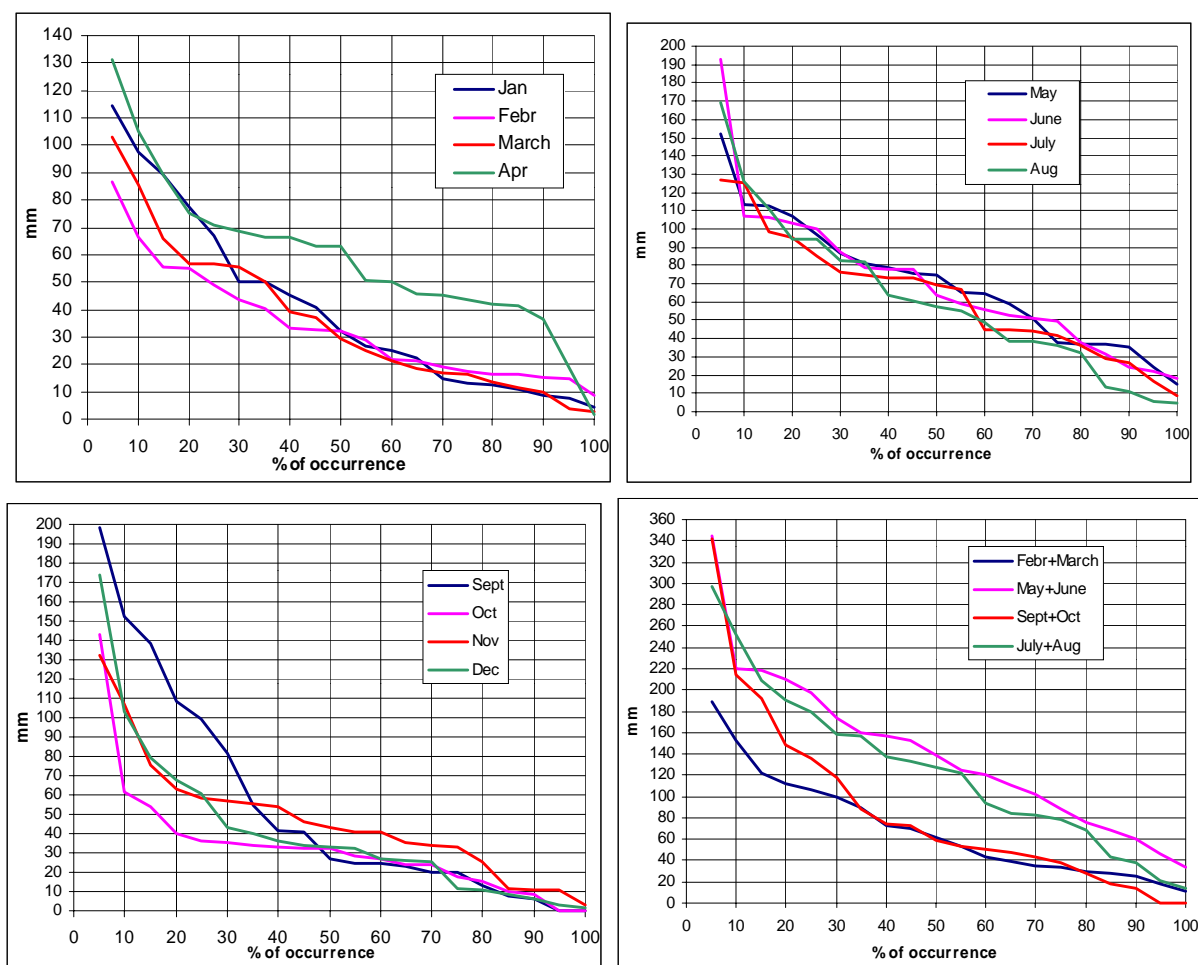

Figure 109 : Occurrence of rainfall events (by month and for 2 consecutive months) for OBRASTZOV CHIFLIK station

Climate in RUSE area seems to be a little bit different from PLEVEN. June is less rainy and rainfalls are more spread over from April till August. During these months the average rainfalls are contained between 50 and 70 mm, with absolute maxima higher than 190 mm in June and September. Frequential analysis (Figure 109) confirms similarity between these months, they can be characterised as follow : rainfalls > 30 mm during 80 % of time, > 55 mm during 50 % of time, > 75 mm during 20 % of time.

7.3.4. Farming systems and practices

7.3.4.1. Major crops

In the year 1991 Bulgaria started to return lands to private sector following structure dating from 1947. It was also decided to break up old agricultural collectivist structures. Farms coming from this context are mainly small and agricultural practices often extremely basic. Following a CE synthesis report Bulgarian agricultural area was in 1998 distributed between 3 types of exploitations:

- Private associations and co-operatives (averaged area of 637 ha) : 42 %,
- public farms managed by State (averaged area of 735 ha) : 6 %,
- small individual exploitations (averaged area of 1.4 ha) : 52 %,

As presented by Figure 110, wheat, barley, maize and sunflower are currently the major crops (55 % of arable lands).

Agricultural area	6159000 ha	
Communal pastures	1516000 ha	
Permanent crops	216000 ha	
Complex and cultivated pastures	426000 ha	
Arable lands	4001000 ha	
of which :		
Wheat	957700 ha	= 23.9 % of arable lands
Barley	260500 ha	= 6.5 % of arable lands
Maize	477800 ha	= 11.9 % of arable lands
Sunflower	499800 ha	= 12.5 % of arable lands
Tobacco	20500 ha	= 0.5 % of arable lands
Sugar beet	8500 ha	= 0.2 % of arable lands
Others, no-cropped	1776200 ha	= 44.4 % of arable lands

Figure 110 : Agricultural lands distribution in Bulgaria

Following information collected on the French foreign trade Internet site there were two groups of agricultural structures at the end of 1996 :

Small private producers. They cultivate an averaged area of about 1.5 ha. Production is intended to auto-consumption and is characterised by a low productivity due to a lack of financial resources and poor knowledge in crop production and management. As presented by Figure 111, maize, wheat and vegetables are the main crops in these farms.

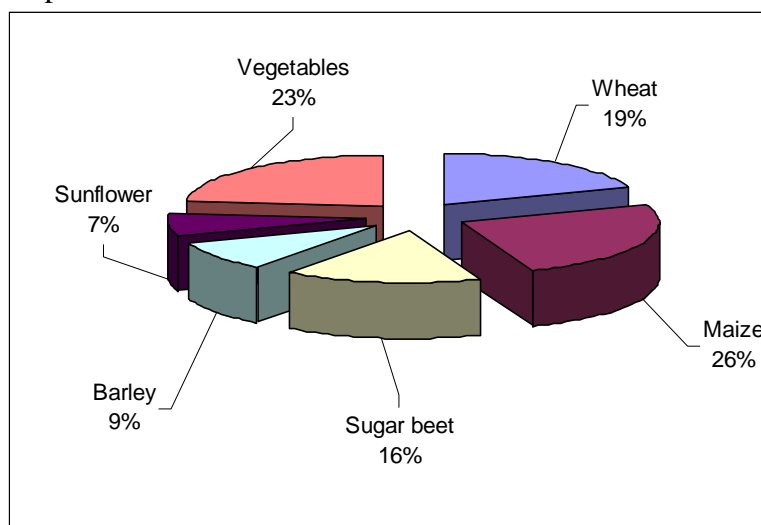

Figure 111 : Main crops cultivated by households in 1995 in Bulgarian Danube watershed

Co-operatives and other kind of associations are increasing since 1992. The averaged area cultivated by a co-operative (with 230 members) is about 748 ha but the most part of them meet the same financial problem as the personal producers. Associations using fertilisers, seeds and pesticides of good quality are rare and an important factor of development lies in qualification of the manager. Following Figure 112, agricultural systems in these associations include winter crops (wheat, barley), spring crops (maize, sunflower, sugar beet) and vegetables around a similar proportion (between 15 and 20 %).

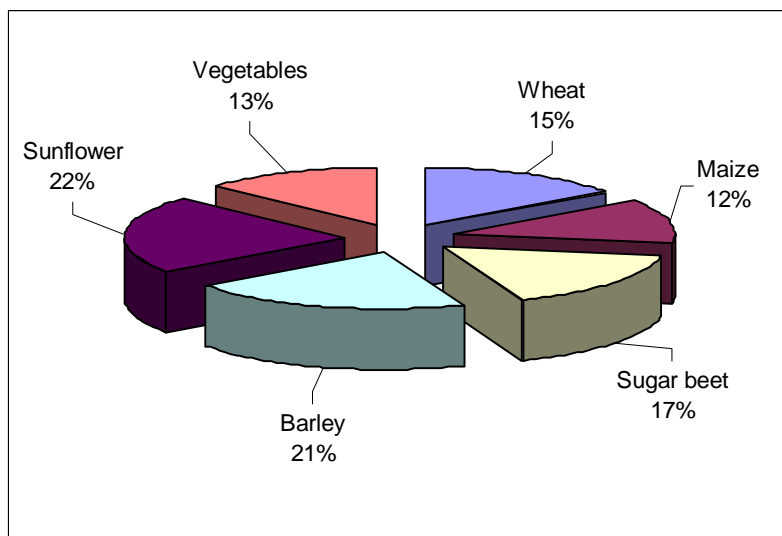

Figure 112 : Main crops cultivated in associations in 1995

Following land privatisation, Bulgarian farming systems seems to be very various. Schedules presented by Figure 113 must be considered as good solutions to assure respectable yields. Unfortunately, it's obvious that fertilisations as well as pesticide treatments and even some soil tillage can't be conducted as follow in structures with financial restrictions.

	Jan	Feb	March	April	May	June	July	August	Sept	Oct	Nov	Dec
Wheat		N fert. (60 kg/ha)		Herb. + Insect.		Fungicide	Insecticide	Harvest Straw harvest	P (100-120 kg/ha), K (100 kg/ha) Mix stubbles Ploughing		N (30 kg/ha) Prepa sowing Sowing	
	7% of wheat is under irrigation											
Maize			N (40-50 kg/ha) + Herb. Prepa sowing Sowing		Herb.	N (40-60 kg/ha) Herbicide				Harvest		
	20% of maize is under irrigation											
Sunflower			N (40-50 kg/ha) + Herb. Prepa sowing Sowing		Mechanical weed killing	N (40-60 kg/ha) Herbicide			Harvest Straw harvest	P (100-120 kg/ha) K (100 kg/ha) Ploughing		
	10% of sunflower is under irrigation											
Sugar beet		N fert + Herb. Prepa sowing Sowing			Dem Herb. + N fert.		Insecticide + Fungicide			Harvest		P, K fert. Ploughing

Figure 113 : Main crops scheduling

7.3.4.2. Livestock

Livestock in Bulgaria decreased a lot during last years (except for caprine) and is still under constant evolution. It seems that actually the ratio "livestock bred in private structure/ livestock bred in Bulgaria" is close to 85 % for cattle (herds with 1 to 5 animals), 95 % for sheep, 78 % for pigs and 83 % for poultry. Figure 114 displays the distribution of Bulgarian livestock between co-operatives and family structures.

	Number of heads			%		
	Total	Co-operative	Family	Total	Co-operative	Family
Total cattle	638238	129141	509028	8.2	9.8	7.9
of which dairy cows	351000			4.5		
Buffalo	13666	1828	11781	0.2	0.1	0.2
Pigs	1986182	924096	1061998	25.6	69.9	16.5
of which sows	219000			2.8		
Sheeps	3397610	261209	3136362	43.7	19.8	48.6
of which ewes	2358000			30.3		
Goats	795436	710	794672	10.2	0.1	12.3
Horses	133045	2422	130557	1.7	0.2	2.0
Donkeys	275627	0	275553	3.5	0	4.3
Mules	15855	105	15684	0.2	0	0.2
Rabbits	516921	2184	514690	6.7	0.2	8.0
Total livestock	7772580	1321695	6450325	100	100	100

Figure 114 : Livestock in Bulgarian in 1995

7.4. Other useful data

In the framework of this project a lot of existing data were collected by eastern partners about soil, climate and farming systems. All these information can provide an overview of agricultural conditions in Danube plain and allow us to build some scenarios corresponding to these averaged situations.

To carry out a more precise analysis it's necessary to detail the description of agriculture as well as the use of rural lands (agriculture, vegetable gardens, ...). More detailed soil maps could allow to precise characteristics, distribution and occurrence of soils in Danube plain. About climate, a better coverage of plain with more stations by county, and with longer series of data could be useful to render variation between some areas.

8. Models utilisation

In accordance with the objective of assignment of an importance in the global nitrate loss to some existing situations (natural environment and farming systems) some data were collected to precise soil and climate characteristics and to propose a farming systems typology. Risks analysis based on this data collection is explained in this chapter.

8.1. Principle and objectives

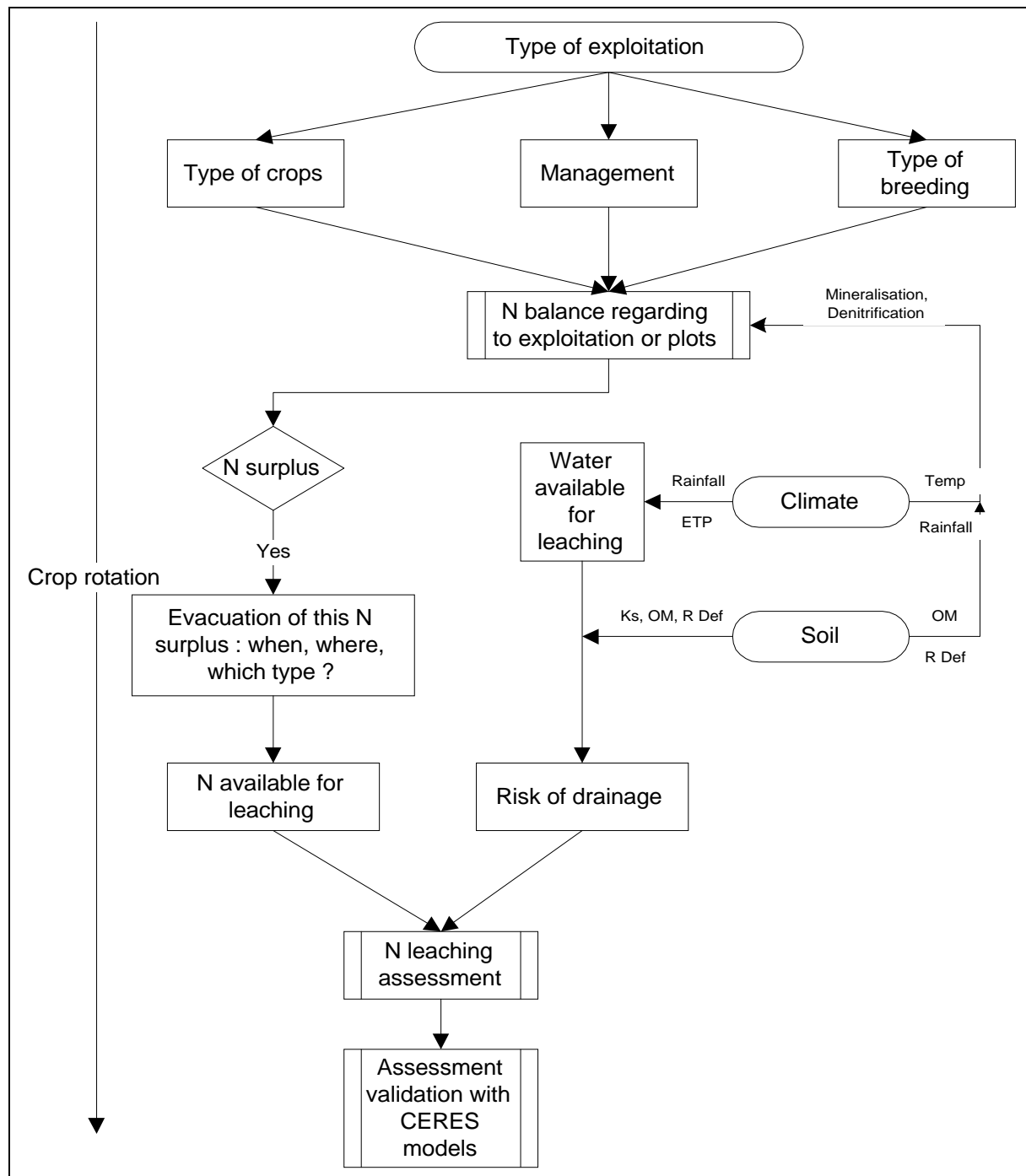

Figure 115 : Risk analysis scheme

Nitrate leaching only occurs if some water is available for drainage and, in the same time, potentially mobile nitrate is present in the soil. Consequently a risks analysis built simultaneously on nitrogen balance of each farming system and on estimation of drainage period and amount allow the evaluation of nitrate loss (Figure 115). Environment influence is taken into account by considering soil and climate characteristics.

In practice it's difficult to quantify complex interactions between physical and biological processes, drainage depends on soil and plant behaviour which itself is function of climate environment. Mineralisation occurs mainly during autumn and spring (following global climate characteristics in our study area) but it's complex to assess exactly the evolution of soil nitrate content regarding to quantity as well as location.

Use of CERES models (with simplified scenario) would be useful in order to take into account all these complex interactions and processes.

8.2. Method

Methodology used to perform risks analysis is split into three major stages (detailed in following chapters) :

- Build scenarios using national data and typology,
- realise risk analysis considering some of them to illustrate methodology,
- run CERES models to identify leaching periods and quantify nitrate losses.

8.3. Romania

8.3.1. Translation into scenario

8.3.1.1. Introduction

Following our objective of farming systems analysis we intend to draw up some “averaged” typical situations considering soil and climate data and farms typology. As climate data are more complete for CALARASI county which covers more than 400 000 ha (11.2 % of cultivated Danube plain) and presents two types of soil (fluvisol: 10 % and chernozems: 90 %) different in their physical and chemical characteristics, this county has been taken as an example. We first analysed agricultural systems and practices in the framework of this representative county.

8.3.1.2. Farming systems

After analysis of farms typology in Romania, following agricultural situations could constitute the basis of some representative scenarios :

1. Farms with a “family” structure, using 59 % of agricultural area :

- a.** E1 : mixed farms with production intended to auto-consumption
area < 3.5 ha intended to livestock,
± 5 cattle, < 40 pigs (in farm buildings and with imported forages),

some sheep stay on pastures of the commune during 6 months,
crops : maize (80% at least), pastures and vegetables,
without mineral fertilisation and pesticides,
organic manure produced on the farm is applied on the farmlands.

b. C1 : phytotechnical farms

area < 10 ha, extensive system on a single plot,
37% maize, 27% wheat, 15% sunflower and 11% vegetables,
low fertilisation rates except on vegetables,
crop residues non harvested and ploughed in.

E2 : mixed farms with a significant part of the crop production destined to the market

area < 10 ha, 10 cattle, 40 pigs and 40 sheep,
main crops : 40% wheat, 35% maize, 15% sunflower and 10% for pastures,
harvest of crop residue used as fodder,
low fertilisation rates and application of available organic manure,
plots are scattered and without irrigation, farmer has problems with transport.

2. C2 : family associations (10 members), phytotechnical farms with a logistic director

30 – 100 ha,

36% wheat, 36% maize, 18% sunflower, small area with vegetables, fruits or fodder.

Typical rotation is S-W-W-M-M-S,

agricultural practices are simple, fertilisation and pesticides rates are low,

crops residue non harvested, no organic fertilisation,

plots are scattered and without irrigation, some members have tractors.

3. Co-operatives :

a. C3 : associations without a legal personality, phytotechnical farms

100 – 300 ha (70 to 300 members),

40% wheat, 30% maize, 12% sunflower, 10% barley,

agricultural practices are more developed and mainly realised by extern firms,

mineral fertilisation is applied on wheat,

crops residues are non harvested.

b. C4 : associations with legal personality, phytotechnical farms

200 to 1500 ha, plots come directly from lands of old state co-operatives,

same crops as **3a** with 5% of sugar beet,

high amount of mineral fertilisation and pesticides treatments are scheduled

following current agricultural practices,

crops residue non harvested.

c. E3 : associations with a legal personality with some animals belonging to members

100 – 700 ha, 30 to 300 members,

the same structure and speculations as **3a** with a small area cropped for fodder,

a part of crop residues are used as fodder,

animals are mainly sheep or pigs,

low organic manure is applied on some plots.

Non-privatised trading societies :

- a. C5 : phytotechnical structures, members are urban people
700 – 1500 ha,
33% wheat, 19% maize, 16% sunflower, 12% barley, 7% soya,
high rates of mineral fertilisers but applied following crops rotations and soil
analysis (≈ 120 kgN/ha), no organic fertilisation,
crop residues non harvested.
- b. E4 : mixed structures with crops and dairy cattle (200 to 800 members)
500 – 1700 ha, with some hectares as pasture,
crop types and management as in **4a**, sometimes with irrigation,
100 to 200 cattle (2/3 are dairy cows staying inside) and < 300 sheep,
small area is intended to fodder crops (permanent pastures, ...),
organic manure produced is applied on some plots, some crop residues used as
fodder.

These agricultural systems are present in the Danube plain, they take place on different soil types and under various climate conditions. CALARASI county could be considered as a representative situation and our analysis will develop on this basis.

8.3.2. Risk analysis

8.3.2.1. Climate in Calarasi county

Rainfall

May, June and July are the more rainy months in CALARASI county (monthly average between 57 and 69 mm, chapter 2 and appendix D), very high absolute maximum can occurs during this period and could become an important factor of risk if fertilisers aren't caught efficiently by crops. However it's obvious that high temperatures (average between 20 and 25°C with maximum close to 40°C) are common during these months. An averaged evapotranspiration could be quickly calculated, or estimated regarding to crop development with CERES model. Winter is probably a more critical period due to negative aspects linked to extreme rainfall and non optimal agricultural practices. November and December show an averaged monthly sum of rainfall of about 50 mm and an amount equal or superior to 70 mm with a frequency of about 20 %.

Drainage can occur when rainfall amount is higher than evapo-transpiration. A potential evapo-transpiration can be calculated on the basis of some simple climate data (temperature and global radiation) by use of Turc formula :

$$\text{MonthlyPET} = 0.40 * \left(\frac{\text{temp}}{\text{temp} + 15} \right) * (Rg + 50)$$

With PET in mm,
temp : averaged monthly temperature in °C,
Rg : global radiation in cal/cm²/day.

Following figures present the evolution of the difference [Rainfall – calculated ETP] in different cases of rainy conditions. Water balance is firstly estimated using 32 years-averaged monthly sums of rainfall, temperature and global radiation (Figure 116), 10 to 45 mm of water seems to be available for drainage during winter months (November to March).

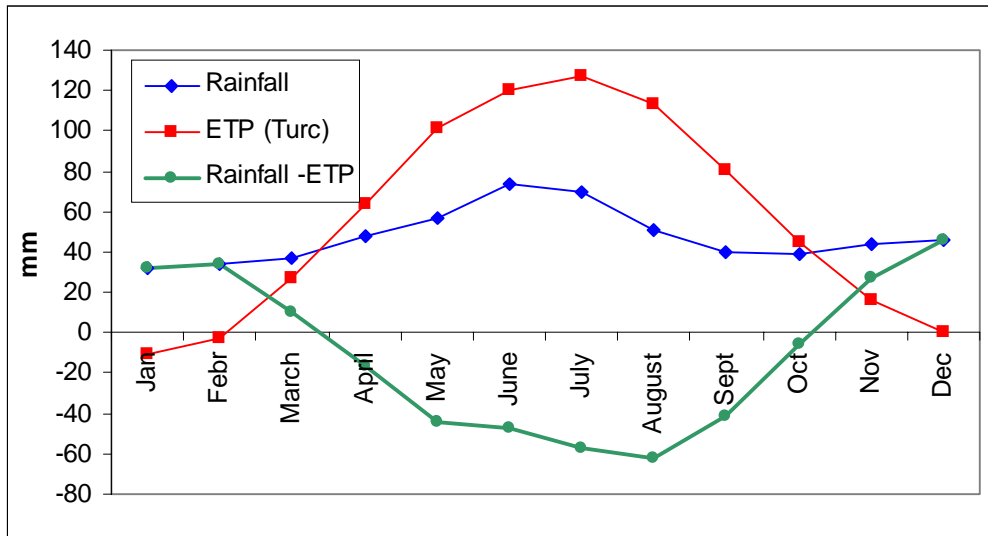

Figure 116 : Monthly deficit in water in Calarasi county (calculated using averaged monthly sums of rainfall, temperature and global radiation)

Of course this averaged situation must be completed taking extreme rainfall events with their percentage of occurrence into account. Figure 117 demonstrates that any drainage is quite improbable during August and September. On the other hand, 28 to 72 mm of drainage could occur between October and March (7 mm in April) with 19 % of occurrence. High amount of leachable nitrate must absolutely stay low during this period.

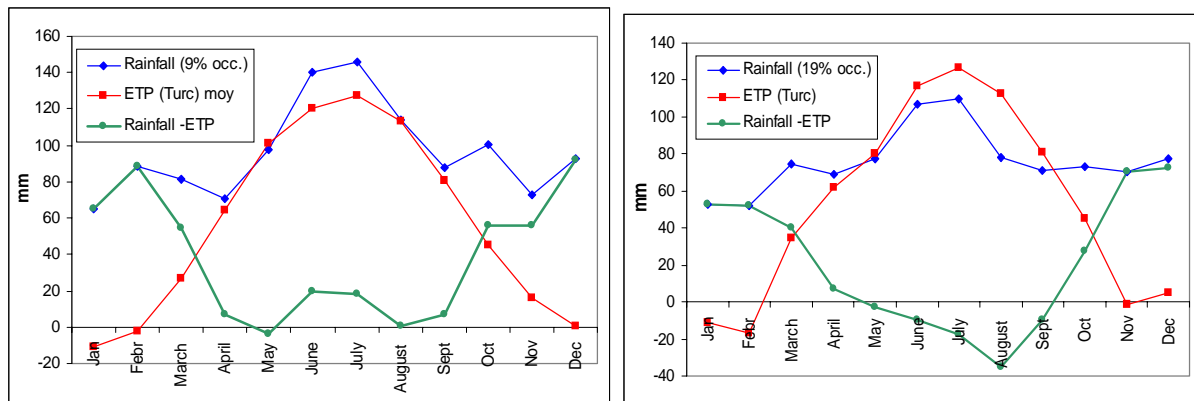

Figure 117 : Monthly deficit in water in Calarasi county (calculated using monthly sums of extreme rainfall with occurrence of 9% and 19% and monthly temperature and global radiation of years corresponding to extreme rainfalls)

Temperature

Some biological process included in the N cycle are highly dependent on the evolution of temperature (among others) along the year. Following Soltner (1990), temperature close to 10-15 °C can maintain microbial activity (optimum : 30 °C) and optimal soil water content is near 2/3 of water holding capacity. The evolution of biological activity leading nitrogen mineralisation can be summarised as follow :

- High amount of water and low temperatures cause a slowing down of mineralisation in winter,
- starting of mineralisation is slow at the beginning of spring and maximum is reached during May and June,
- processes stay intense during summer only if humidity is sufficient,
- mineralisation starts again during autumn but winter rainfalls can leach nitrate if it is not used by crop.

8.3.2.2. Soils in Calarasi county

Fluvisols are situated near Danube and Dimbovita river coming from Bucharest, they are fertile soils mainly made up of coarse sand with a saturation conductivity contained between 50 and 110 cm/day. C/N ratio is close to 10 in surface horizons (where humus is about 12 but less than 1 in subsurface horizons). Chernozems, the major soils in CALARASI county, are black soils rich in organic matter ($5 < \text{humus} < 15$, $C/N \approx 14$). They have a high moisture holding capacity and a saturation conductivity contained between 24 and 90 cm/day.

Chernozems and Fluvisols cover respectively 14.6 % and 11.5 % of Romanian lands. Their characteristics as well as their locations are quite different and constitute a useful compromise to build an overview of situations with nitrate leaching risk.

A qualitative analysis will be conducted considering characteristics of these soils. On an other hand, CERES models can be useful to quantify nitrate leaching in some precise situations of soil, climate, agricultural practices and crops rotations. In the context of this project models were calibrated and validated using some pre-defined soil situations. Complex input files with physical and chemical soil characteristics build on this occasion will be used taking into account some adaptations due to different working hypothesis.

8.3.2.3. Farming systems, analysis of some scenario

The typology of Romanian agricultural exploitations presented in chapter 7 was useful to consider some scenarios covering the great part of agricultural systems in Romania. Some of them will be used as example to explain the methodology of risk analysis.

Family structures constitute an important part of lands use and could, as small exploitations with low financial provisions, low level of mechanisation, and rough knowledge in agronomy, contribute to nitrate leaching risk. Farms marked by **E1** (see chapter 7) will be analysed to illustrate nitrate losses due to high organic manure production and/or bad distribution.

On the other hand family associations (**C2**) with phytotechnical activity, with low financial resources (and consequently low mineral fertilisation) and without livestock (except for some animals belonging to members), show consequently a low risk of nitrate leaching and will be considered to illustrate usefulness of CERES model in a more complex crops succession.

Finally, nitrate leaching could come from larger exploitations where high amounts of mineral fertilisation are applied. Non-privatised societies with crops and dairy cattle (**E4**) can represent this category.

Production and composition of manure and crop residues

Data about volume and composition (nitrogen content) of organic manure produced by different type of farming animals can be found in literature. A handbook (1994) sponsored by

the “Cabinet du Ministre de l’Environnement, des Ressources Naturelles et de l’Agriculture pour la Région Wallonne” describes organic manure produced by Belgian livestock and Meisinger and Randall (1991) gives the same type of information for American herds. Following norms will be used in this study :

Manure production

bull and dairy cattle (450 kg) : 60 kgN/year (12 tons of manure per year),
sheep and goat (45 kg) : 6 kgN/year (1 ton of manure per year),
sow (100 kg) : 24 kgN/year (4 tons of manure per year),
horse (450 kg) : 52 kgN/year (6.5 tons of manure per year).

Manure composition

cattle manure : 25% D.M.; 18% O.M.; C/N = 14; 5 kgN/ton; 0.5 kg NH₄/t,
ovine manure : 30% D.M.; 23% O.M.; C/N = 23; 6 kgN/ton,
caprine manure : 30% D.M.; 23% O.M.; C/N = 23; 6 kgN/ton,
pig manure : 21% D.M.; 16% O.M.; C/N = 12.5; 6 kgN/ton,
horse manure : 54% D.M.; 41% O.M.; C/N = 20; 8 kgN/ton; 2.1 kg NH₄/ton.

Estimated N contents of the harvested portion of main crops (Meisinger and Randall, 1991)

wheat : 2.3 % N (grain), 0.65 % N (straw),
barley : 2.1 % N (grain), 0.73 % N (straw),
maize : 1.55 % N (grain), 1.25 % N (silage),
sunflower : 2.70 % N (seed),
sugar beet : 1.7 % N (tops), 1 % N (roots),
alfalfa : 3.55 % N.

Organic matter restitution for main crops (Soltner, 1990)

wheat : 2 tons M.S./ha (roots), 4 tons M.S./ha (aboveground parts), C/N \pm 100,
barley : 1 tons M.S./ha (roots), 2.5 tons M.S./ha (aboveground parts), C/N \pm 100,
corn maize : 2 tons M.S./ha (roots), 4 tons M.S./ha (aboveground parts), C/N \pm 100,
sugar beet : 0.8 tons M.S./ha (roots), 4 tons M.S./ha (aboveground parts), 15<C/N<20,
green manure : 1 ton M.S./ha (roots), 3 tons M.S./ha (aboveground parts), 15<C/N<20.

Mixed farms with production intended to auto-consumption (E1)

Area : 3.5 ha, with 80 % of maize, 10 % of pastures and 10 % of vegetables.
Livestock : 5 cattle (dairy cows and bull), 20 pigs, 20 sheep.
No mineral fertilisation.
Due to lack of mechanical power organic manure is non-uniformly applied.
Cattle graze during 6 months on pastures belonging to family.
Sheep stay on communal pastures during 6 months.
Pigs stay in farm buildings during all the year.
Stems of maize are used for heating.

Nitrogen production – distribution on lands

Considering norms specified above this farming system can be analysed as follow :

- Cattle stay during six months on pastures (0.35 ha) and produce 150 kg of nitrogen.
- Sheep grazing on communal pastures during six months produce 60 kg of nitrogen which can be considered out of the system.
- Pigs, cattle and sheep produce together 120 tons of manure (corresponding to 690 kg of nitrogen) with the following averaged composition : 22.7 % dry matter, 17 % organic matter, C/N ratio equal to 13.7.
- Organic matter restitution after maize coming from roots and a small part of stubble can be estimated as equal to 2 tons dry matter / ha with \pm 1.25 % of nitrogen (25 kg N/ha)

Permanent pastures receive each year 428 kg N /ha due to cattle grazing. Manure (120 tons) produced by livestock staying inside is spread on maize (2.8 ha) and vegetables (0.35 ha) as organic fertilisation. Vegetables are probably cropped next to farm and could consequently receive high amount of manure. Unfortunately, it's hard to quantify this observation and we'll assume that manure is uniformly distributed on maize and vegetables. Therefore these crops receive 219 kg of nitrogen per hectare (38 tons of manure/ha).

Farming systems analysis

Figure 118 summarises manure production by livestock and its distribution on agricultural lands.

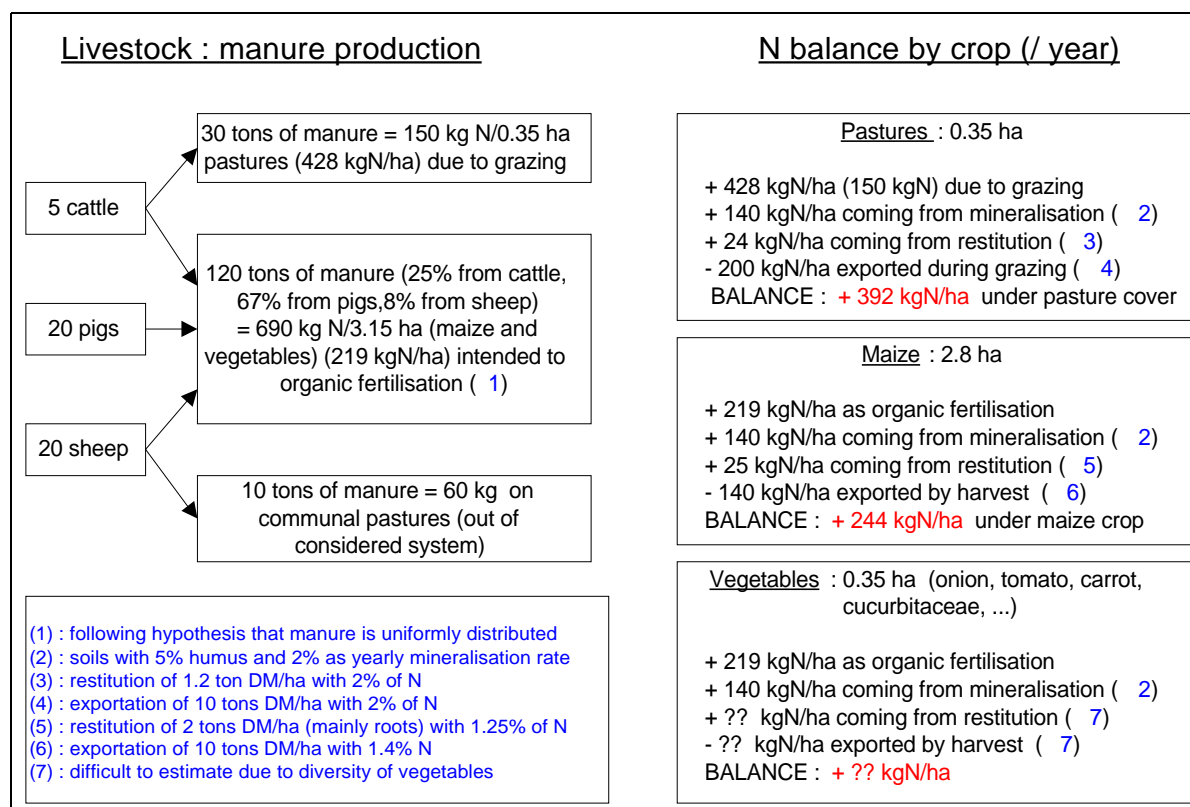

Figure 118 : Mixed farms with production intended to auto-consumption (E1) : farming system analysis

This analysis is based on some probable hypothesis regarding farming system, manure production and nitrogen balance is quantified by use of some norms commonly accepted (Follet *et al.*, 1991; Soltner, 1990 and 1999; Recous, 1995; Ziegler & Heduit, 1991). Cattle grazing as well as organic fertilisation with manure amassed during winter months lead to high nitrogen surplus on lands belonging to this type of exploitation. Particularly, high amount of nitrate accumulated on pastures during grazing months and manure spread on maize and vegetables during inter-crop are probably available for leaching during drainage period.

Considering nitrogen balances of Figure 118 and drainage periods and amounts shown by Figure 116 (deficit in water calculated using averaged monthly sums of rainfall) and Figure 117 (deficit in water calculated using monthly sums of extreme rainfall with occurrence of 19%), an averaged nitrogen concentration of leached water could be estimated. Unfortunately Turc formula allowing calculation of a potential evapo-transpiration (PET) was used for each month, considering then that soil is covered with a well developed vegetation during all the year. In fact, soil stays bare during 6 months and water availability during summer is weak, consequently real evapo-transpiration is probably over-estimated.

However it's interesting to calculate the difference between yearly sum of rainfall and yearly sum of PET in presence of an averaged sum of rainfall and on the basis of the more rainy year. In the first case, summer deficit is high and yearly water balance is negative, no drainage could occur. In a rainy year a lot of drainage will happen in winter season after restoring of soil water stock. Use of CERES model will allow quantification of these complex processes.

Scenarios for modelling

Maize is cropped on the same plot without irrigation and mineral fertilisation. It is sown on 15/04 and harvested on 15/10. 38 tons per hectare of manure (22.7 % D.M., 17 % O.M., C/N=13.7) is spread yearly. Crop residues (roots and a small part of stubble) are equal to 2 tons DM/ha (1.25 % N, C/N=100). Calibrated and validated soil files corresponding to Chernozem (Fundulea) and Luvisol (Bucharest) are available and will be used for modelling. The averaged yearly sum of rainfall (calculated on a basis of 32 years) in Fundulea is equal to 569.4 mm. Maize model will be used with climate files corresponding to the more rainy year (1969 with 890.5 mm) and an "average year" (1975 with 576.4 mm).

Results of modelling (complete results in appendix G)

Figure 120 displays the nitrogen balance of maize monoculture on Chernozem soil and under two rainfall events of Fundulea climate. Under a medium year (regarding to rainfall) soil water balance is negative and no drainage can occur, loss of nitrate is not possible and soil nitrogen content increases each year (Figure 119).

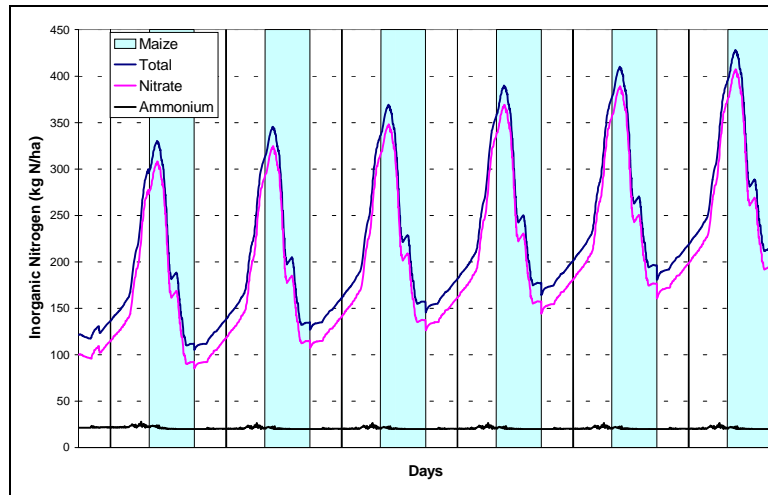

Figure 119 : Soil nitrogen content increase under Fundulea climate of 1975

Under the more rainy year of our climate data series (1969) rainfall exceeds soil real evapotranspiration and water is available for drainage which happens during the first seven months of the year, under bare soil as well as at the beginning of maize crop development. After high consumption during summer, water is used to restore soil stock till the end of December.

After high organic fertilisation nitrogen is available for leaching during these seven months and a total of 32 kg of nitrogen are lost each year, nitrogen concentration of drained water stays lower than 15 mg N/litre.

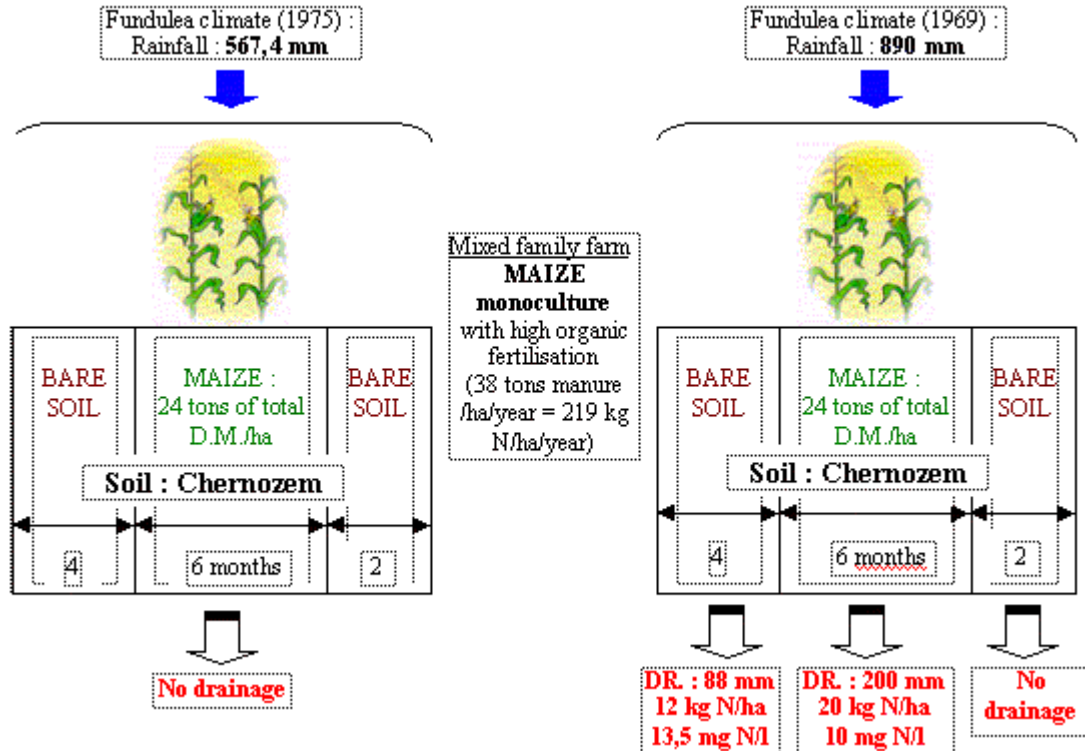

Figure 120 : Modelling of maize monoculture under Fundulea climate : nitrogen balance

Finally it's obvious that due to a positive nitrogen balance, this farming system can lead to leaching of nitrate if water is available for drainage. Losses showed by simulation with

CERES-maize model could be quite higher if, as in our nitrogen balance analysis, production of biomass was reduced, e.g. by use of less productive maize varieties.

Family associations, phytotechnical farms with a logistic director (C2)

Area : 75 ha, with 36 % of wheat, 36 % of maize, 18 % sunflower and 10 % of vegetables.

Typical crops rotation is sunflower-winter wheat-winter wheat-maize-maize-sunflower.

Agricultural practices are simple, fertilisation (1/2 of optimal amount) and pesticides rates are low (only herbicide on wheat).

Crop residue non harvested, no organic fertilisation.

Plots are scattered and without irrigation.

Crops rotation

According to numerous authors of which Soltner (1999), due to risks of fungi diseases, sunflower can't be cropped on the same plot without a break of at least 3 years. Bausson and Tison (1994) explain that due to a non-optimal fungicide protection this profitable crop stands only on 15 to 20% of agricultural area in Romanian rotations. In this case of "crop products" associations agricultural land could be distributed as follow :

	Plot 1 (13,5 ha)	Plot 2 (13,5 ha)	Plot 3 (13,5 ha)	Plot 4 (13,5 ha)	Plot 5 (13,5 ha)	Scattered plots (7,5 ha)
1st rop of rotation	Sunflower	Maize	Maize	Winter wheat	Winter wheat	Vegetables
2nd crop of rotation	Winter wheat	Sunflower	Maize	Maize	Winter wheat	Vegetables
3rd crop of rotation	Winter wheat	Winter wheat	Sunflower	Maize	Maize	Vegetables
4th crop of rotation	Maize	Winter wheat	Winter wheat	Sunflower	Maize	Vegetables
5th crop of rotation	Maize	Maize	Winter wheat	Winter wheat	Sunflower	Vegetables

Figure 121 : Plots distribution in a sunflower-wheat-maize-maize rotation in C2 structures

Vegetables are probably cropped independently of the agricultural rotation on scattered plots in gardens located next to housing of each member. Crops rotation presented by Figure 121 and Figure 122 will be analysed regarding to N balance of a single plot. At the same time CERES models used to simulate a complete crops rotation would allow identification of potential leaching.

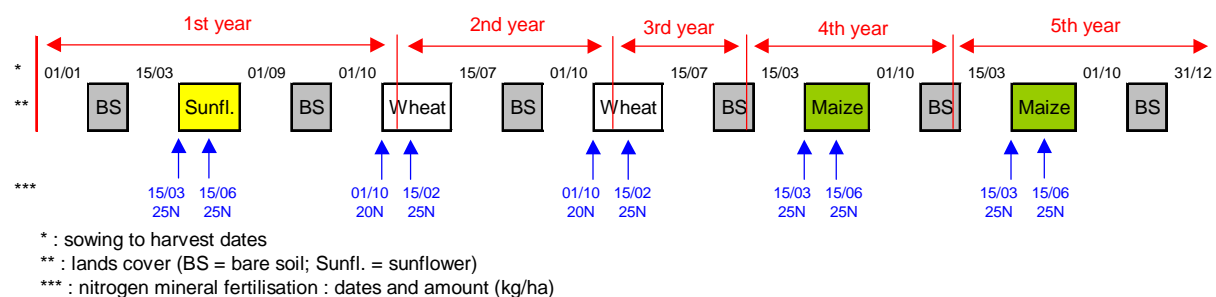

Figure 122 : Crops rotation (dates and cover) on a particular plot

Farming system analysis

Figure 123 summarises, crop by crop, assessment of nitrogen balance on a particular plot. As previously this analysis was conducted with some probable hypothesis regarding lands distribution. Due to low yields (particularly with wheat and maize) nitrogen exportations are weak and total balance is positive at the rotation scale.

To identify leaching risk it's essential to consider potential drainage and periods with high content of nitrate in soil. Due to its fast growth, sunflower is able to catch a large part of nitrate coming from mineral fertilisation and from spring mineralisation (except for nitrate coming from autumnal mineralisation which is probably located in deeper horizons). Harvest causes a considerable restitution of biomass, a small part would be mineralised before winter and leached if drainage occurs. Then a small nitrogen fertilisation is applied before wheat sowing to help establishment of crop, the main part of sunflower residues is probably mineralised during following spring and is not caught by wheat because of low productivity of this crop in this agricultural structure (poor varieties, low fungicide protection, ...), however mineral N stays available in the upper layers due to lack of drainage.

Organic matter restitution after winter wheat is quite weak or non-existent if straw is burned. According to Laurent & Eschenbrenner (1995) straw burning usually causes an increase of nitrogen soil content during non-cropped period because any carbon coming from straw is available for activity of soil microbial biomass, moreover a large amount of straw nitrogen is lost by volatilisation. Nitrogen balance is still positive and nitrate coming from spring mineralisation or from acceleration of biological activity with autumnal rains will be progressively lost because it can't be entirely caught by following winter wheat.

Following years of the rotation are probably more critical because nitrogen balance of maize crop is still positive and non-cropped period are longer. Drainage will depend on evolution of stock of soil water. It's quite difficult to quantify nitrate lost during crops rotation because the organic matter turn over is divided between autumnal and spring mineralisation and because assessment of water distribution between soil, crop and drainage is not easy. Use of CERES models offers the possibility to take into account all components of this complex scheme. Regarding to potential improvement of agricultural practices it's interesting to precise that with this kind of rotation, soil stays uncovered during 37 % of time (679 days).

<u>N balance by plot (/ 5 years)</u>	
<u>Bare soil</u>	
<u>Sunflower</u>	
+ 50 kgN/ha as mineral fertilisation (1)	
+ 56 kgN/ha coming from mineralisation (2)	
+ 72 kgN/ha coming from restitution (3)	
- 54 kgN/ha exported by seeds harvest (4)	
BALANCE : + 124 kgN/ha	
<u>Bare soil</u>	
<u>Winter wheat</u>	
+ 45 kgN/ha as mineral fertilisation (1)	
+ 56 kgN/ha coming from mineralisation (2)	
+ 19,5 or +/- 0 kgN/ha coming from restitution (5)	
- 40 kgN/ha exported by harvest (6)	
BALANCE : + 80.5 or + 61 kgN/ha	
<u>Bare soil</u>	
<u>Winter wheat</u>	
+ 45 kgN/ha as mineral fertilisation (1)	
+ 56 kgN/ha coming from mineralisation (2)	
+ 19,5 or +/- 0 kgN/ha coming from restitution (5)	
- 40 kgN/ha exported by harvest (6)	
BALANCE : + 80.5 or + 61 kgN/ha	
<u>Bare soil</u>	
<u>Maize</u>	
+ 50 kgN/ha as mineral fertilisation (1)	
+ 56 kgN/ha coming from mineralisation (2)	
+ 75 kgN/ha coming from restitution (7)	
- 62 kgN/ha exported by harvest (8)	
BALANCE : + 119 kgN/ha	
<u>Bare soil</u>	
<u>Maize</u>	
+ 50 kgN/ha as mineral fertilisation (1)	
+ 56 kgN/ha coming from mineralisation (2)	
+ 75 kgN/ha coming from restitution (7)	
- 62 kgN/ha exported by harvest (8)	
BALANCE : + 119 kgN/ha under maize crop	
<u>Bare soil</u>	
TOTAL BALANCE : + 523 or + 484 (if wheat straw is burned) kgN/ha	
<p>(1) : following hypothesis that 1/2 of optimal mineral fertilisation is applied</p> <p>(2) : soils with 2% humus and 2% as yearly mineralisation rate</p> <p>(3) : restitution of 6 tons DM/ha with 1.2% of N</p> <p>(4) : exportation of 2 tons DM/ha with 2.7% of N</p> <p>(5) : restitution of 3 tons DM/ha (roots and straw) with 0.65% of N or 0.45 ton DM/ha with 0,15% of N if strow is burned</p> <p>(6) :exportation of 2 tons DM/ha with 2% of N</p> <p>(7) :restitution of 6 tons DM/ha with 1.25% of N</p> <p>(8) :exportation of 4 tons DM/ha with 1.55% of N</p>	

Figure 123 : Family associations, phytotechnical farms (C2) : farming system analysis

Scenarios for modelling

Calibrated and validated soil files corresponding to Chernozem (Fundulea) and Luvisol (brown-reddish soil of Bucharest) and climate files corresponding to years 1969 and 1975 will be used for modelling.

A crops rotation (sunflower-winter wheat-winter wheat-maize-maize) is simulated using CERES-wheat, -maize models. Following calendar will be used :

Maize model for Sunflower :

15/03 : mineral fertilisation : 25 kg N /ha,
01/04 : sowing : 7 plants/m²,
15/06 : mineral fertilisation : 25 kg N /ha,
01/09 : harvest : 4 tons DM (grains)/ha (1.55% N),
crop residues : 6 tons DM/ha (1.25% N ; C/N = 100),

Winter wheat 1 and 2 :

15/09 : mineral fertilisation : 35 kg P and K /ha, ploughing,
01/10 : mineral fertilisation : 20 kg N /ha, sowing : 550 grain/m²,
15/02 : mineral fertilisation : 25 kg N /ha
15/07 : harvest : 2 tons DM (grains)/ha (2% N),
crop residues (roots and straw) : 3 tons DM/ha (0.65% N ; C/N = 100),
or crop residues (straw burned) : 0.45 tons DM/ha (0.15% N ; C/N = 1),

Maize 1 and 2 :

15/10 : mineral fertilisation : 30 kg P and K /ha, ploughing,
15/03 : mineral fertilisation : 25 kg N /ha,
01/04 : sowing : 7 plants/m²,
15/06 : mineral fertilisation : 25 kg N /ha,
01/10 : harvest : 4 tons DM (grains)/ha (1.55% N),
crop residues : 6 tons DM/ha (1.25% N ; C/N = 100).

Results of modelling (complete results in appendix G)

In this crops rotation soil water flows are more complex than in the previous simulation, occurrence of drainage events depends on interaction between consecutive water uptake and rainfall events. Two simulations with different assumptions regarding to rainfall amount were realised, with the soil characteristics of the Chernozem, and they will be analysed independently.

Figure 124 shows jointly the evolution of extractable soil water, cumulated drainage and NO₃ leaching under a medium yearly sum of rainfall and on Chernozem of Fundulea. Chronologically no drainage occurs between sunflower crop and sowing of second wheat. Stock of water is indeed very low after sunflower and because of a short period with bare soil it can only be progressively restored during wheat inter-crop and winter.

A small drainage can happen under this “second” wheat crop if intense rainfalls occur before the end of March but the more critical period begins rather with wheat harvest.

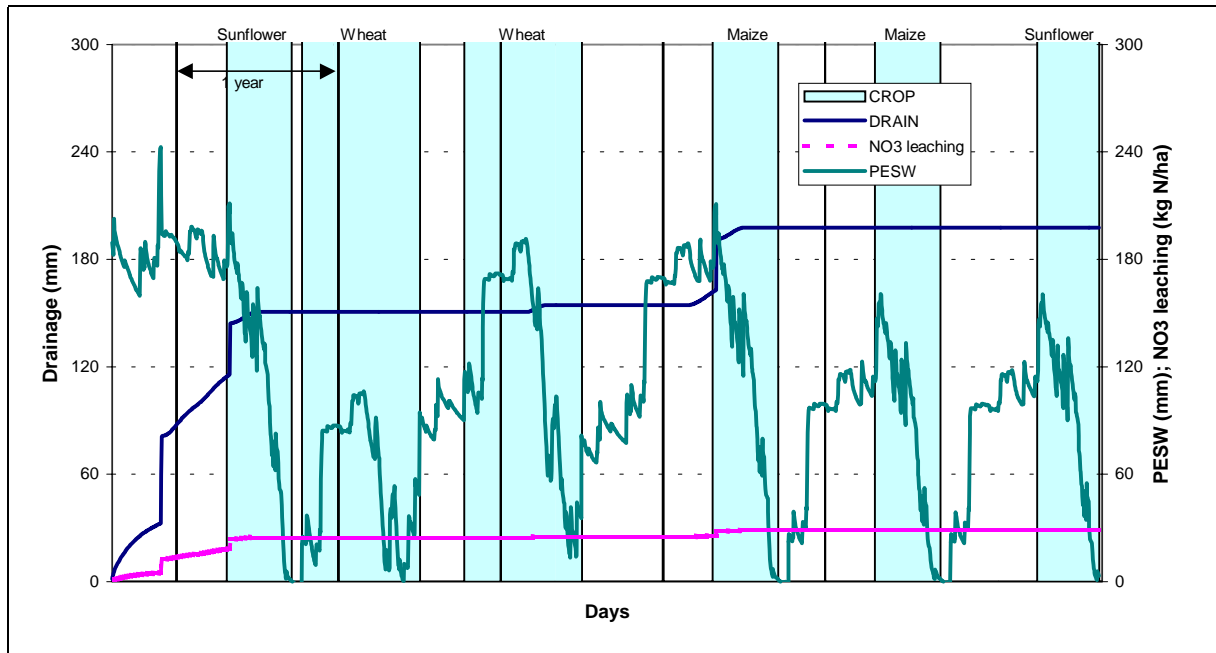

Figure 124 : Soil water content, cumulated drainage and leaching under Fundulea climate of 1975 – Sunflower-wheat-wheat-maize-maize rotation

Winter wheat is harvested earlier than spring crops, therefore although its water content is very weak, the land stays uncovered during 8 months after harvest and drainage can occur in April and until June. Later successive Maize and Sunflower crops exhaust soil water stock and winter rainfall are too low to restore it completely.

In this simulation two drainage periods happen just after a mineral nitrogen fertilisation but nitrate leaching stays very low. Mineral nitrogen is probably completely distributed between crop uptake and immobilisation.

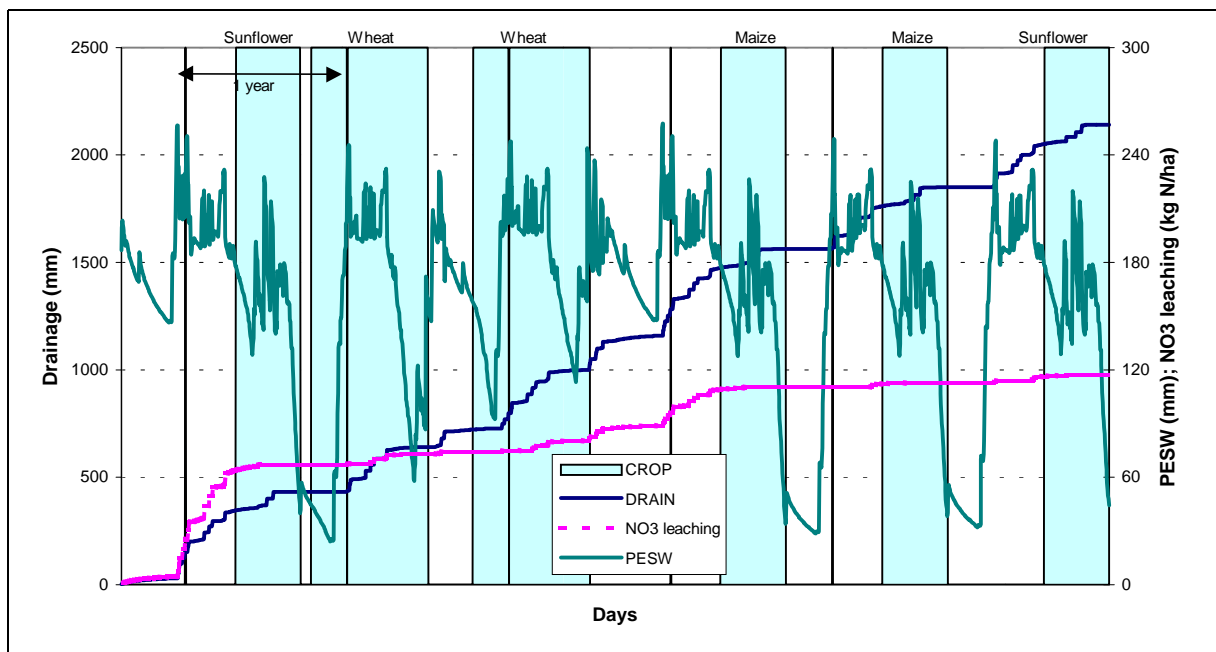

Figure 125 : Soil water content, cumulated drainage and leaching under Fundulea climate of 1969 – Sunflower-wheat-wheat-maize-maize rotation

Under rainy conditions (Fundulea climate, year 1969) water flows are completely different and leaching can happen during all the year. To resume results presented by Figure 125 the crops rotation will be analysed in two parts.

Under spring crops there isn't any drainage between July and December. Soil water stock is indeed low after harvest and this deficit can only be filled in by rainfalls at the end of December. On the other hand some water is available for drainage between January and July but as previously nitrate leaching during this period is lower than 5 kg/ha. Crop uptake is probably high and drainage stays weak during mineral fertilisations.

Interaction between crop water use and rainfalls are completely different under winter wheat. In rainy conditions of year 1969, drainage is permanent under this crop. However it stays low during two periods : mid-April to mid July and mid August to mid-December, separated by 20 to 30 days (following amount of produced biomass) of intense drainage due to high amount of rainfall.

To summarise, on Chernozem of Fundulea, the biggest loss of nitrate (30 kg/ha) under this crops rotation occurs during winter wheat – maize inter-crop even with a permanent drainage the total nitrate loss under wheat crop stays lower than 10 kg/ha. Water flows respond to the same dynamic with the soil characteristics of Bucharest (Luvisol). However, nitrate leaching stays lower, probably due to differences regarding to initial nitrogen conditions and mineralisation coefficient.

Trading societies, mixed structures with crops and dairy cattle (E4)

Area : 1000 ha, with 33 % of wheat, 19 % of maize, 16 % sunflower, 12 % of barley, 7% of soy bean , 5 % of sugar beet and 8 % of temporary pasture.

high rates of mineral fertilisers but applied following crops rotations and soil analysis (≈ 120 kgN/ha), irrigation (by open channels and sprinklers) is often applied.

150 dairy cows (high productivity) and 50 bulls (< 400 kg) staying inside.

Organic manure produced is applied on some plots.

Nitrogen production by cattle

In this farming system bulls as well as dairy cows stay inside and are sustained among other with forage produced by vegetal sector. Considering norms previously presented, cattle produce 2400 tons of manure per year with composition showed by Figure 126.

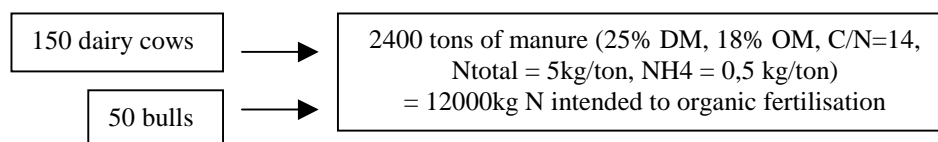

Figure 126 : Manure production by livestock in E4 system

Lands distribution

Size of agricultural area, financial and mechanical resources are main factors which could explain diversity of types of crop met in this farming system. Previous crops percentage could be considered as a systematic crops rotation, in this case Figure 127 shows an example of lands distribution in a society with 1000 ha of arable lands.

R1	Sunflower Winter wheat Maize Barley	120 ha of Sunflower	120 ha of Wheat	120 ha of Maize	120 ha of Barley	480 ha = 48% of agricultural area
R2	Sunflower Winter wheat Maize Winter wheat	20 ha of Sunflower	20 ha of Wheat	20 ha of Maize	20 ha of Wheat	80 ha = 8% of agricultural area
R3	Sunflower Winter wheat Sugar beet Winter wheat	20 ha of Sunflower	20 ha of Wheat	20 ha of Beet	20 ha of Wheat	80 ha = 8% of agricultural area
R4	Sugar beet Winter wheat Temporary pasture Temporary pasture	20 ha of Beet	20 ha of Wheat	20 ha of Pastures	20 ha of Pastures	80 ha = 8% of agricultural area
R5	Soya Winter wheat Temporary pasture Temporary pasture	20 ha of Soya	20 ha of Wheat	20 ha of Pastures	20 ha of Pastures	80 ha = 8% of agricultural area
R6	Soya Winter wheat Maize Winter wheat	45 ha of Soya	45 ha of Wheat	45 ha of Maize	45 ha of Wheat	180 ha = 18% of agricultural area

5 ha soya
5 ha maize are scattered on lands
10 ha Sugar beet

Figure 127 : Crops rotation in trading societies with cattle (E4) – agricultural area : 1000 ha

Agricultural system analysis

Some of previous crops rotations will be analysed regarding to nitrogen balance. Following hypothesis that organic manure is only applied on maize or sugar beet crops of rotation without pastures (R1, R2, R3 and R6), 12 tons of nitrogen are spread on 205 ha. These rotations receive 58 kg of nitrogen par ha with liberation of 45, 20 and 10 % of nitrogen respectively during 1st, 2nd and 3rd years.

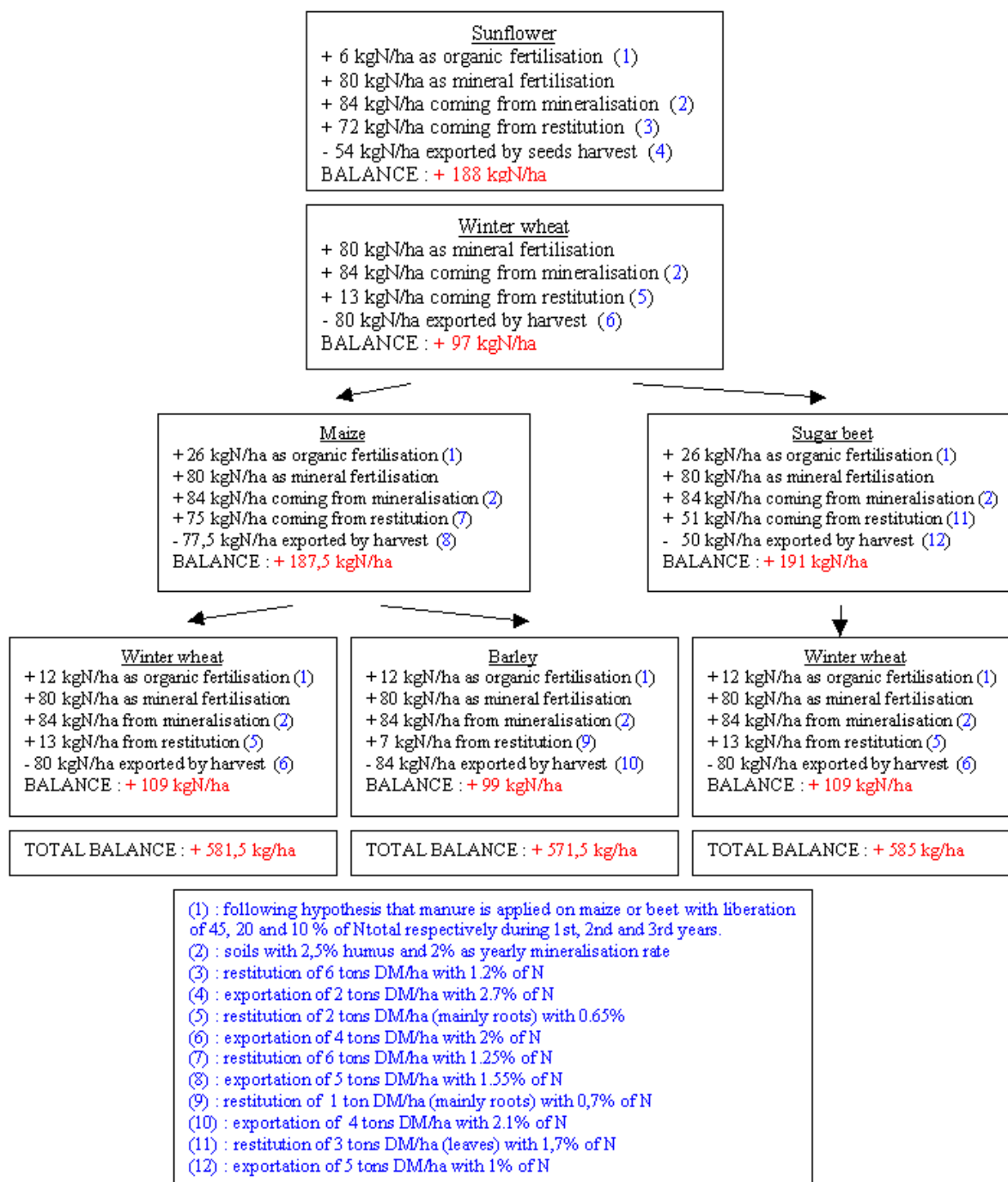

Figure 128 : Trading societies with cattle (E4) : R1, R2 and R3 rotations : N balance

Some societies with a smaller vegetal sector can be found in Romania, agricultural area is mainly intended to fodder crops and additional forage comes sometimes from other farms. Nitrogen balance is consequently quite different and organic fertilisation is more important. In this case, crops rotations presented by Figure 129 cover the major part of agricultural area.

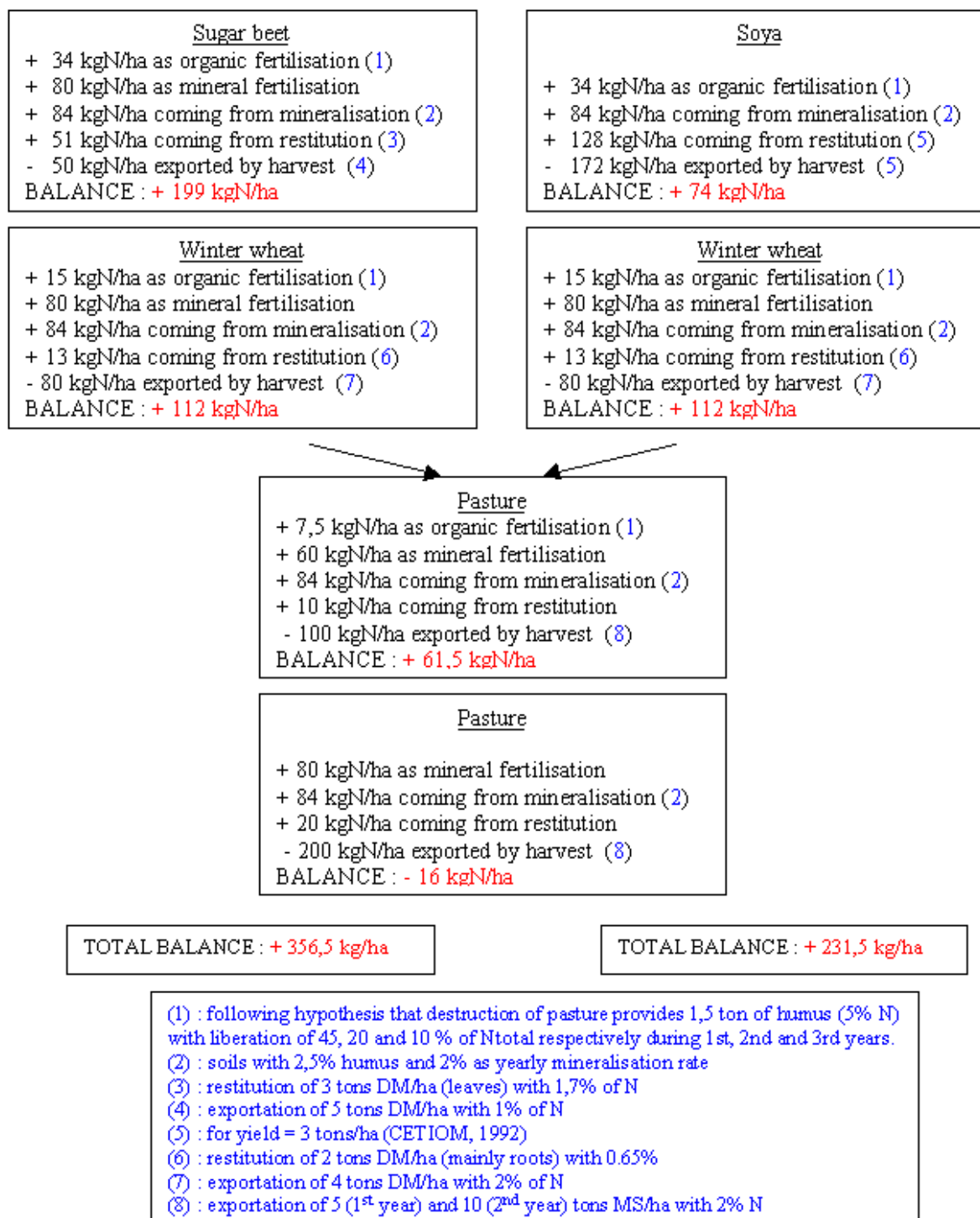

Figure 129 : Trading societies with cattle (E4) : R4 and R5 rotations : N balance

Figure 128 shows nitrogen balance of crops rotations “R1”, “R2” and “R3”. These rotations with alternately winter and spring crops have probably the same nitrogen dynamic which could be analysed as follow.

Sunflower harvest brings a lot of biomass residues, a small part mineralised during autumn could be leached during winter because nitrogen demand of winter wheat is low at this period

and, moreover, mineral fertilisation is applied before sowing. Nitrogen coming from spring mineralisation is partly used by wheat crop which has a better potential yield.

Unfortunately nitrogen balance of these two crops is still positive and nitrogen progressively mineralised during autumn and spring could be leached if soil stays uncovered during drainage period and if high amounts of rainfall occur. Then the same nitrogen dynamic is repeated with the following two crops.

By use of CERES models we will be able to quantify drainage in presence of different rainfall events as well as nitrate potentially leachable regarding to period of the year.

Nitrogen balance of “R4” and “R5” rotations (Figure 129) is quite different. In this case, soil stays uncovered in winter during one or two (if temporary pasture is sown in spring) years only. Sugar beet balance is highly positive due to high amount of humus released after burying of pasture and fresh residues due to harvest. This restitution of easily mineralisable biomass and mineral fertilisation occurring before sowing of wheat could cause nitrogen leaching.

Nutrients leaching is less probable under pasture mainly because exportation is important. However nitrogen balance could be quite different on pastures managed with high amount of organic fertilisation, for example in farms with high cattle load and smaller agricultural area.

Scenarios for modelling

Covering 48% of agricultural area “R1” is the major crops rotation in trading societies, however its nitrogen dynamic should be similar with Sunflower – Wheat – Beet – Wheat rotation (R3). Consequently and to test CERES model intended to sugar beet again following schedule will be simulated (firstly without organic fertilisation which is difficult to distribute along the crops rotation) :

Maize model for Sunflower :

15/03 : mineral fertilisation : 40 kg N /ha,
01/04 : sowing : 7 plants/m²,
15/06 : mineral fertilisation : 40 kg N /ha,
01/09 : harvest : 5 tons DM (grains)/ha (1.55% N),
crop residues : 6 tons DM/ha (1.25% N ; C/N = 100),

Winter wheat :

15/09 : mineral fertilisation : 70 kg P and K /ha, ploughing,
01/10 : mineral fertilisation : 40 kg N /ha, sowing : 550 grain/m²,
15/02 : mineral fertilisation : 40 kg N /ha
15/07 : harvest : 4 tons DM (grains)/ha (2% N),
crop residues (mainly roots) : 2 tons DM/ha (0.65% N ; C/N = 100),

Sugar beet :

01/03 : mineral fertilisation : 40 kg N /ha,
01/04 : sowing : 10 plants/m²,
01/05 : mineral fertilisation : 40 kg N /ha,
01/10 : harvest : 5 tons DM (roots)/ha (1% N),
crop residues : 3 tons (leaves) DM/ha (1.7% N ; C/N = 19).

Winter wheat : as previously.

As previously, calibrated and validated soil files corresponding to Chernozem and Luvisol and climate files corresponding to years : 1969, 1975 will be used again for modelling.

Results of modelling (complete results in appendix G)

As in previous simulations concerning a crops rotation, soil water flows are complex and drainage events depend on interaction between consecutive water uptake and rainfall events. Two simulations with different hypothesis regarding to rainfall amount were realised again.

The same drainage dynamic is observed in this crops rotation as in sunflower-wheat-wheat-maize-maize rotation. Particularly, as showed by Figure 130 which presents results of simulation conducted under climate conditions of year 1975, water content is weak after wheat harvest but as the soil stays uncovered during 8 months soil water stock is restored with autumnal rainfalls and drainage can occur from January to July. On the other hand sugar beet and sunflower crops exhaust soil water stock and winter rainfall are too low to restore it completely. Nitrate leaching stays weak (<5kg/ha under cropped and bare soil), probably due to competition with immobilisation.

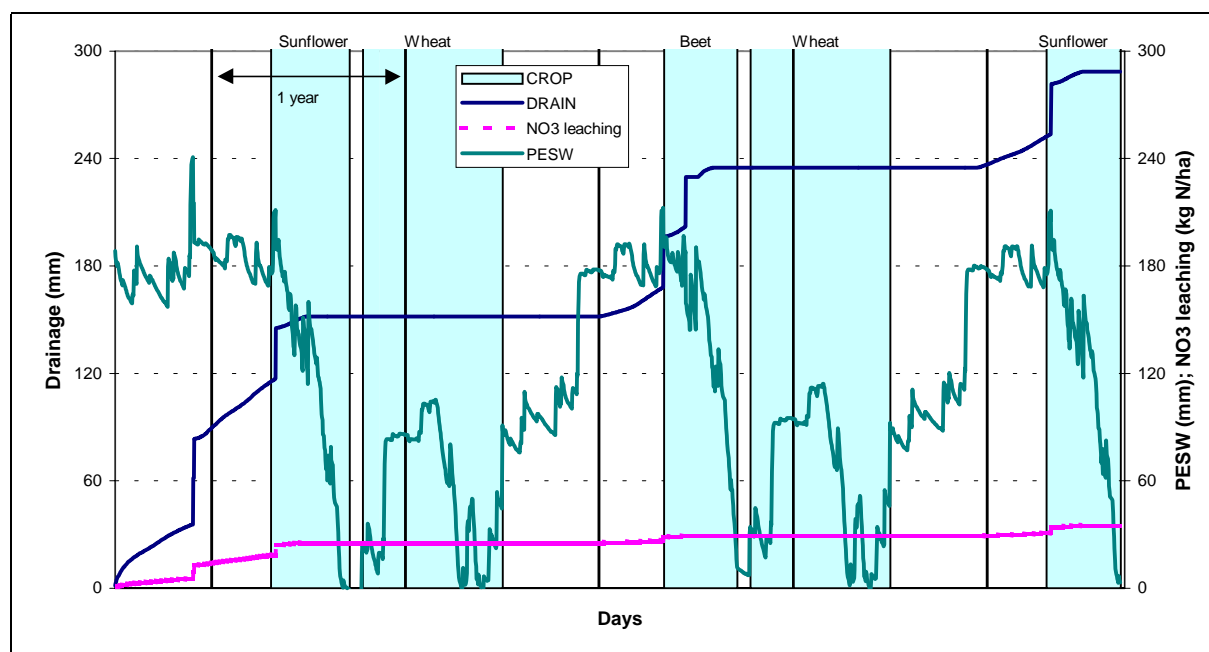

Figure 130 : Soil water content, cumulated drainage and leaching under Fundulea climate of 1975 – Sunflower-wheat-sugar beet-wheat rotation

Under rainy conditions (Fundulea climate, year 1969) the same drainage dynamic is also observed as in sunflower-wheat-wheat-maize-maize rotation. Under sugar beet and sunflower there isn't any drainage between July and December. Soil water stock after harvest is low and the deficit is only fill in by rainfalls at the end of the year. Small drainage happens between January and July but nitrate leaching stays lower than 5 kg/ha probably because of an intense immobilisation.

Drainage is more important under winter wheat and occurs from January to mid of April when crop uptake is quite low regarding to rainfall amount. Due to crop uptake and progressive restoring of soil stock, it stays low between mid-April to mid-December.

To summarise, on Chernozem of Fundulea, the biggest losses of nitrate under this crops rotation occurs during first winter wheat crop (15 kg/ha) under high amount of rainfall or latter (around beet sowing : 5 kg/ha) under less rainfalls and before sowing of sunflower (19 kg/ha). Nitrate mineralised during autumn and spring seems to be leached when high amount of water is available for drainage. To rationally take into account organic fertilisation, further details could be search regarding manure distribution on lands and model adaptability regarding to progressive nitrogen release from manure must be assessed.

8.3.3. Conclusion

Through simultaneous global analysis of farming systems based on the concept of nitrogen balance and modelling of some crops rotations it has been possible to identify more precisely which farming practices lead to risk of nitrate loss.

Nitrogen balances are often positive and each rotation leads to an increase of nitrate that will be leached if water is available for drainage. In different simulations nitrate leaching occurs under maize mono-culture cropped with high organic fertilisation (during crop and inter-crop periods when water is available) and between January and July in mixed winter-spring crops rotations mainly due to long inter-crop periods with bare soil.

8.4. Bulgaria

8.4.1. Translation into scenario

8.4.1.1. Soils and climate

With PLEVEN and OBRASTZOV stations (20 years of data) we have an overview of climate in Bulgarian Danube plain. Four soil types covering 78.5 % of Danube watershed can be found around these places.

Ortic luvisols are moderately permeable heavy loams (conductivity at saturation "Ksat" between 17 and 34 cm/day and Field Capacity ranges from 29 to 30 %), calcaro-calcic chernozems are high permeable sandy to silty loams ($173 < K_{sat} < 518$ cm/day, $23 < FC < 27$), haplic chernozems are less permeable than previous chernozems ($8.6 < K_{sat} < 34.6$ cm/day) and Fluvisols are porous alluvial soils.

8.4.1.2. Farming systems

Using data collected about farming systems in Bulgaria it was not possible to establish a precise typology of agricultural structures. Farming systems can only be approximated by use of averaged data. Consequently following structures and practices must be viewed as averaged situations drawn thanks to analysis of national data.

1. Family farms with livestock and crops :

- arable crops : 1.5 ha. Some pastures,
- 19% wheat, 9% barley, 26% maize, 7% sunflower, 23% vegetables, 16% sugar beet,
- wheat, maize, barley and vegetables are use for auto consumption ; productions coming from sunflower and sugar beet are sold,
- 6 cattle on pastures belonging to farm, 14 pigs staying inside, 40 sheep and 10 goats (grazing on communal pastures during 6 months), 5 horses (or donkey or mules).

2. Co-operatives :

- arable crops : 748 ha (15% of wheat, 21% barley, 12% maize, 22% sunflower, 13% vegetables, 17% beet),
- a part of wheat, maize and barley is used for auto consumption,
- mineral fertilisations and pesticides treatments are possible according to financial situation,
- 40 cattle are grazing on pastures belonging to co-operative, 290 pigs, 82 sheep.

Various agricultural structures take place in Danube plain and could be deduced from previous averaged situations by use of some supplementary data.

8.4.2. Risks analysis

For the moment, using available data and following hypothesis that some similarities exist between current Romanian and Bulgarian agriculture, two farming systems similar to some Romanian structures will be analysed with Bulgarian soil and climate (PLEVEN, OBRASTZOV) characteristics.

8.4.2.1. Climate (rainfall)

As in Fundulea the more rainy months in PLEVEN and OBRASTZOV areas are May, June and July with a monthly average between 61 and 75 mm. During this period monthly potential evapotranspiration (estimated by use of Turc formula) is significant (Figure 131) and any water is available for drainage.

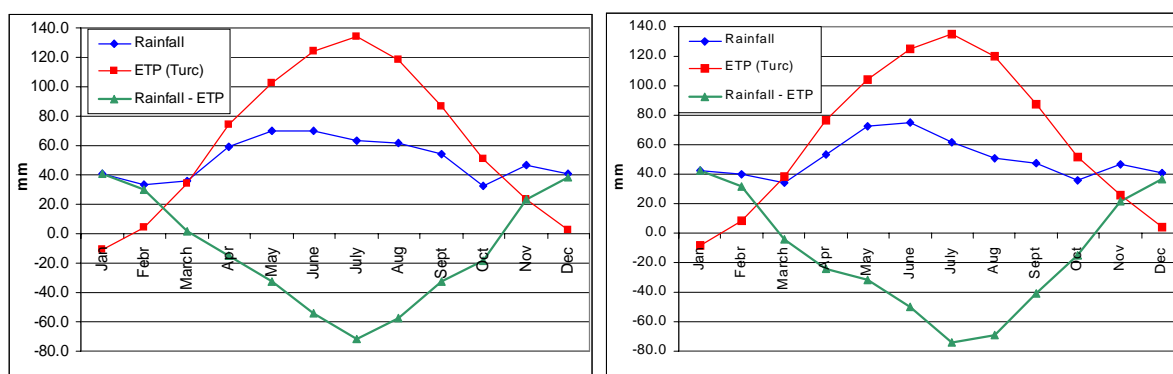

Figure 131 : Monthly deficit in water in PLEVEN (left) and OBRASTZOV (right) stations (calculated using averaged monthly sums of rainfall, temperature and global radiation) – 20 years of data

On the other hand high absolute maximum occurring on September and October could be more critical (Figure 132) regarding to leaching risk. Taken as a whole, drainage period would be contained between September and March, therefore the amount of leachable nitrate must absolutely stay low during this period.

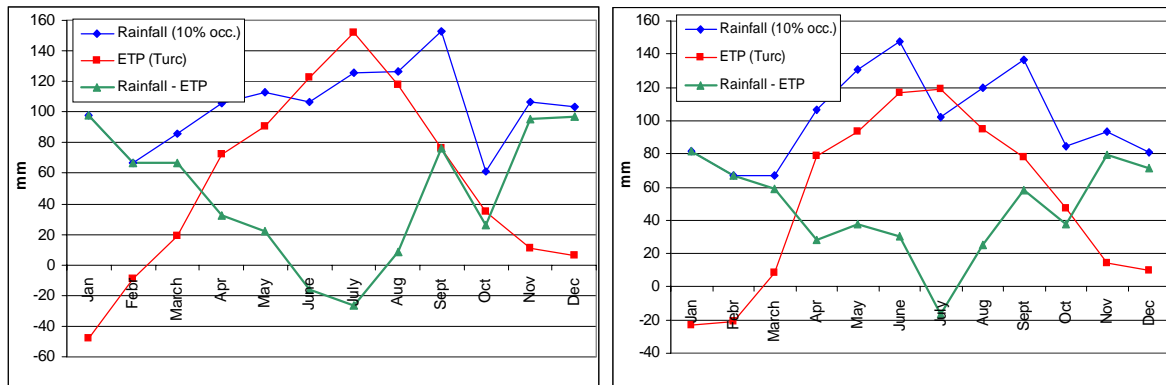

Figure 132 : Monthly deficit in water in PLEVEN (left) and OBRASTZOV (right) stations (calculated using monthly sums of extreme rainfall with occurrence of 10% and monthly temperature and global radiation of years corresponding to extreme rainfalls)

8.4.2.2. Farming systems, analysis of scenario

Small individual exploitations with an averaged area of 1.4 ha cover 52% of agricultural area and due to low level of mechanisation and weak knowledge in agronomy could contribute to risk of nutrients loss. Different types of private associations have in possession an important part of agricultural lands (42%), with data currently available we haven't the opportunity to detail the high variety of their activities. In this context and considering experience accumulated with analysis of some Romanian scenario we'll analyse two types of representative farming structures.

Family farms with livestock and crops

2 ha (60% maize, 20% pastures, 20% vegetables).

+/- 5 cattle, < 10 pigs, 20 sheep, 2 horses.

Total auto consumption.

No mineral fertilisation.

Cattle graze during 6 months on pastures belonging to family.

Sheep stay on communal pastures during 6 months.

Pigs stay in farm buildings during all the year.

Stems of maize are used for heating.

Farming system analysis

Figure 133 : Family farms with livestock and crops in Bulgaria

As Romanian family farming, this analysis demonstrates that grazing and organic fertilisation with manure stored in farm buildings lead to nitrogen surplus on lands. Following mineralisation cycles, nitrate will be released in soil and loss could occur if yearly sum of rainfall exceeds sum of real evapo-transpiration.

Organic manure supply is scheduled as in Romanian family farming, climate is similar to the one considered in previous chapter, the risks and conclusion are identical. Variation caused by climate differences could be assess by analysis of following system with CERES models.

Phytotechnical co-operatives

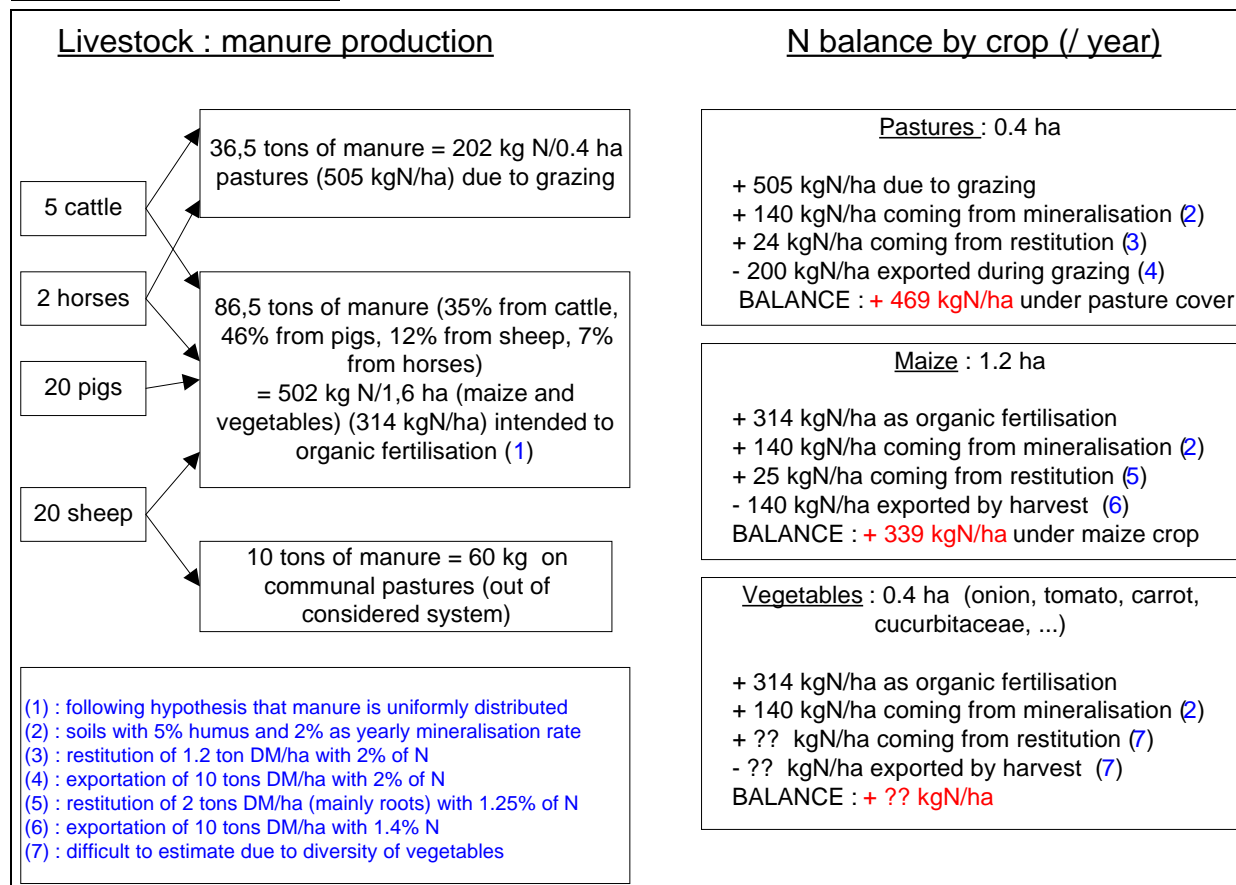
Around 100 ha are cropped with “sunflower-winter wheat-winter wheat-maize-maize” rotation.

Agricultural practices are simple, fertilisation rates are low.

Crop residue non harvested, no organic fertilisation.

Plots are cropped without irrigation.

On the basis of the same crops rotation (sunflower - winter wheat - winter wheat – maize - maize) as in phytotechnical cooperatives (C2) in Romania, the same scenario for modelling will be used, except that CERES models will be run with Bulgarian soils and climate characteristics.

Scenario for modelling

Crops rotation presented by Figure 134 is simulated using CERES-wheat and -maize models.

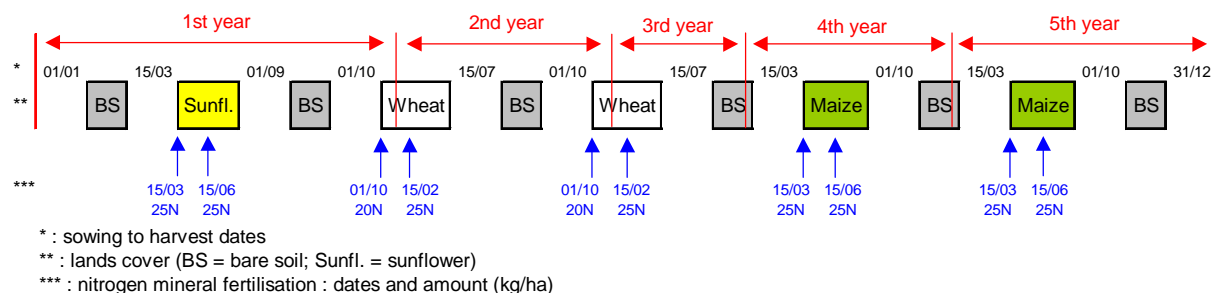

Figure 134 : Crops succession on a particular plot as simulated (with CERES models) under Bulgarian climate – phytotechnical co-operatives

Climate files (20 years) coming from PLEVEN and OBRASTZOV (RUSE) stations are the basis of following different scenarios regarding to yearly sum of rainfall :

PLEVEN : the more rainy year is 1966 with 758 mm and 1971 is a year with a medium yearly sum of rainfall (606 mm).

OBRASTZOV : following the same method : it rained 847.9 mm in 1969 and 611.6 mm in 1976.

Calibrated and validated soil files corresponding to Chromic Luvisol (Chelopechene) and Vertisol (Bojurishte) are available and can be used for modelling. Results obtained by use of permeable Chelopechene soil will be firstly analysed in this section. The case of simulations realised with swelling soil of Bojurishte station will be discussed in another chapter.

Results of modelling (complete results in appendix G)

Figure 135 shows the result of a simulation realised on the basis of Pleven climate (medium year regarding to rainfall) and Chelopechene soil (chromic Luvisol). It was chosen to illustrate the location of a potential leaching risk under Bulgarian conditions.

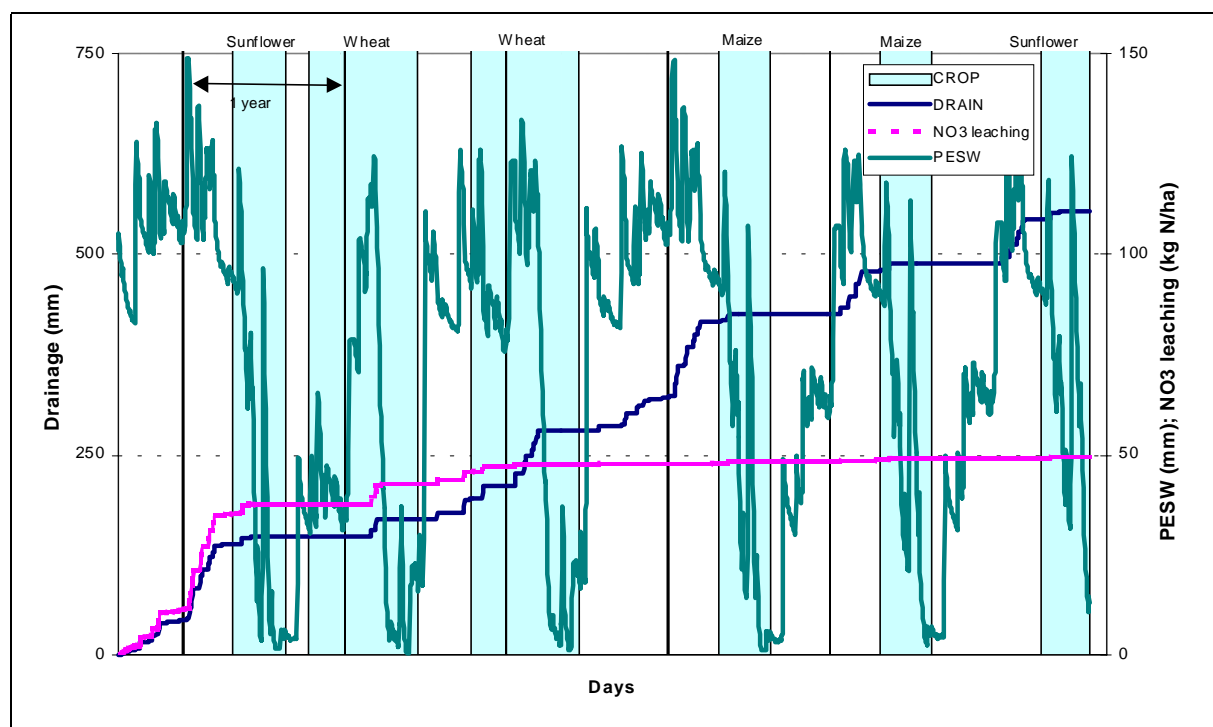

Figure 135 : Soil water content, cumulated drainage and leaching under Pleven climate of 1971 and with soil characteristics of Chelopechene – Sunflower-wheat-wheat-maize-maize rotation

Observations regarding to the same crops rotation conducted in Romania are still valid in this case. However some differences exist in water flows, they are linked to calibration of input files, regarding to some soil parameters mainly and to CERES model which must be improved to modelise more efficiently the nitrogen evolution in soil in presence of soils with high ammonium content (as in Bulgarian data). Water distribution is indeed connected to biomass simulation and then to available nitrogen in soil which depends itself on competition between mineralisation and immobilisation.

Analysis of simulations realised on the basis of Chelopechene soil and with climate files coming from Pleven and Obrastzov stations leads to the same conclusions, mainly because averaged climates are similar.

Drainage happens as soon as soil water stock is restored by autumnal and winter rainfalls. Critical periods stay during wheat-wheat and wheat-maize inter-crops and during the first half part of second wheat season because water stock can be restored early (July). Under spring crops, drainage occurs from January to April when soil layers stay at field capacity. The main difference resulting from use of Obrastzov climate is due to weak sum of rainfall during January, February and March in 1976 followed by intense rains in April.

In each simulation, nitrate leaching is relatively low, probably because available nitrogen is distributed between immobilisation and crop uptake which suffers of a severe nitrogen stress. As noted above models must be improved for simulation with these soils. In this crops rotation nitrogen balance of each crop is indeed still positive and would lead to higher nitrate mineralisation.

8.4.3. Conclusion

Data collected about farming systems in Bulgaria didn't allow establishment of a precise typology of agricultural structures. Farming systems were approximated using averaged data. Nevertheless a short global analysis and simulation of a representative crops rotation in various climate and soil conditions were conducted to illustrate our methodology and realise a first identification of leaching risk and critical situations.

As previously, nitrogen balance by crop are often positive and drainage happens during inter-crop or at the beginning of crop development when water consumption by crop is null or weak.

8.5. Software improvement to perform risk analysis

Another approach of risk analysis consists in characterising a probability of risk from results of series of simulations ranged in ascending order (Pang *et al.*, 1998). The grain yield, drainage and nitrate leaching data were ranged separately and their cumulative probability function was calculated as follows:

$$\text{Cumulative probability (\%)} = i / (n + 1)$$

Where i is the i th year (after the data have been arranged in ascending order) and n is the total number of years (16 years here). An automated application (Figure 136) was developed to perform the simulations and extract the results in easy-to-use output files. We illustrate here the grain yield and two environmental impacts, drainage and nitrate leaching, for simulations of maize on the reddish-brown forest soil of Bucharest.

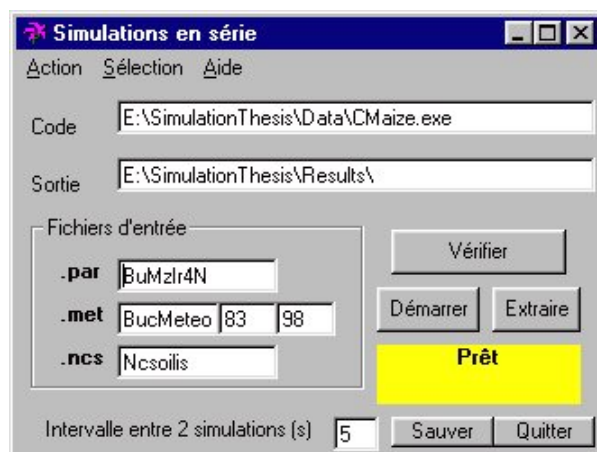

Figure 136 Software interface to simulate consecutive years with the same soil parameters and extract specific results, such as Yield, Drainage and N leaching.

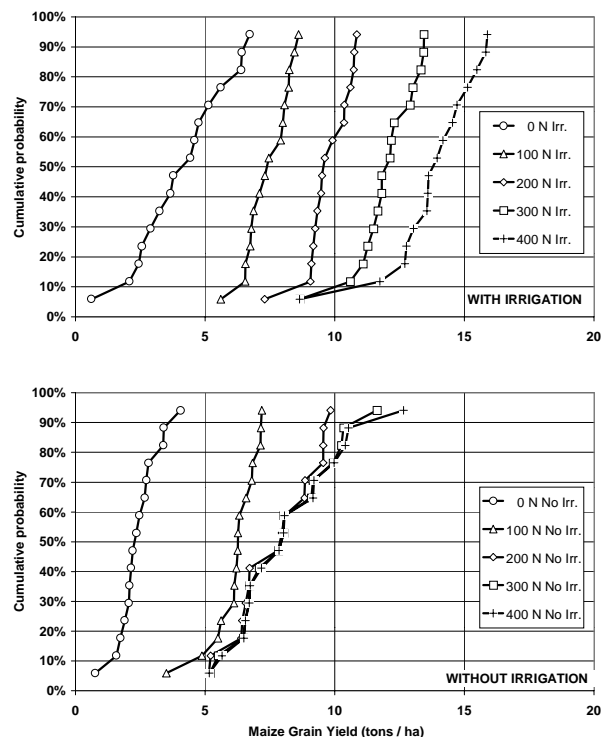

Figure 137: Cumulative probabilities of maize grain yield as a function of 5 fertilizer application rates with and without irrigation.

Figure 137 shows that grain yield is strongly correlated to mineral nitrogen applications, especially when water is not a stress factor either. With irrigation, the yield probabilities are clearly distinct with increasing nitrogen doses, ranging from near to zero to more than

15 t/ha. The means of yield (50% of probability) obtained are 4, 7, 9, 12 and 14 t/ha for 0 to 400 kg N/ha with a step of 100 kg N/ha, respectively. Without irrigation, the yields are systematically inferior, and above 200 kg N/ha, the yield is only affected by the water stress, and nitrogen is no longer a factor of stress.

Except in extreme conditions, corresponding to large amounts of rainfall and no fertilisation, so that few water is used by the crop and therefore remains in the soil, drainage is not correlated to fertilisation on this soil (Figure 138). In the conditions of Bucharest, the main factor for drainage is the amount of irrigation, with 150 to 400 mm (10%-90%) compared to 30 to 100 mm without irrigation. Exceptional weather events provoked up to 600 mm and 200 mm with and without irrigation, respectively.

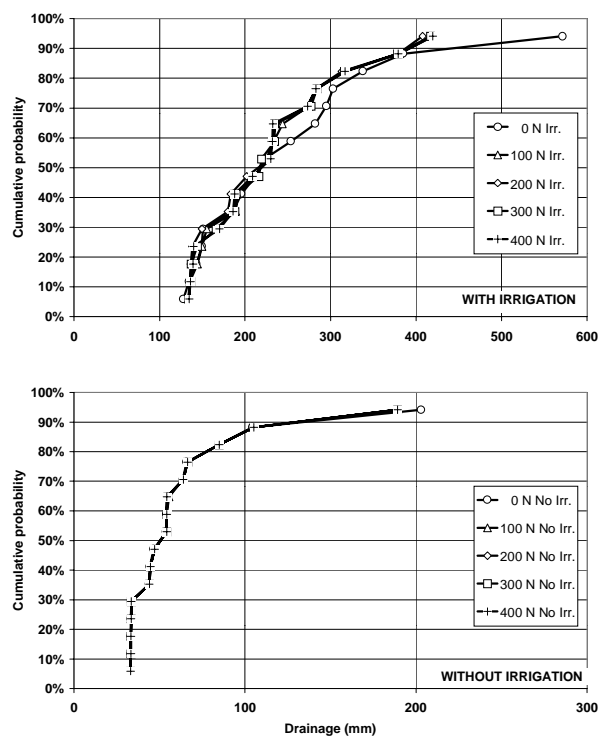

Figure 138 Cumulative probabilities of drainage as a function of 5 fertiliser application rates with and without irrigation

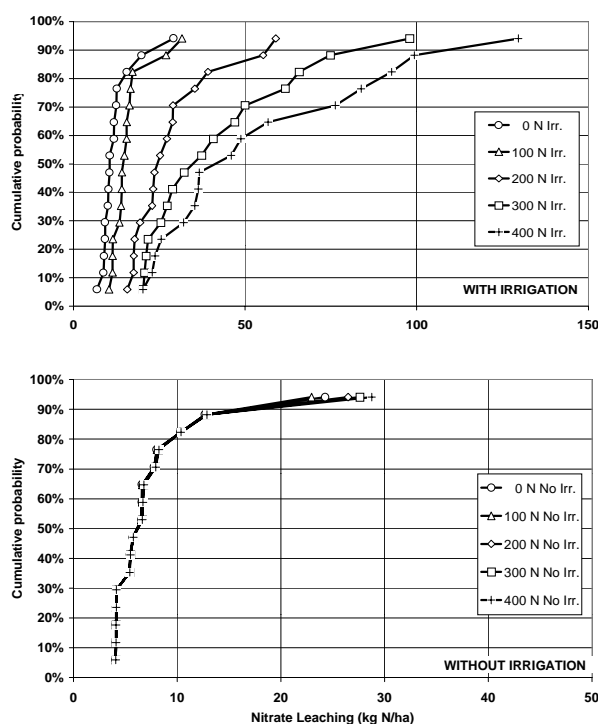

Figure 139 Cumulative probabilities of Nitrate leaching as a function of 5 fertiliser application rates with and without irrigation

With low drainage obtained in non-irrigated conditions, few nitrate leaching is observed, independent from mineral fertiliser application (Figure 139), clearly correlated to drainage. Conversely, with irrigation, drainage is function of weather conditions and N application rate. For 0 to 100 kg N/ha, N leaching remains weak but already superior to that simulated without irrigation. It means that almost all the nitrogen applied is uptaken by the crop. Beyond 200 kg N/ha, larger amount of nitrate remains available to leaching in the profile. In extreme conditions the losses of nitrate range from 30 to 130 kg N/ha.

9. Limits, recommendations and perspectives

Risks assessments and scenarios have been carried on with the aim of proposing some first recommendations which can be directly applied to the agriculture in the concerned areas and which must still be adapted and improved in the future. So, recommendations are divided in two groups:

- recommendations to research in order to improve the situation knowledge and the risks assessments,
- recommendations to agriculture in order to reduce the risks of pollution resulting from farming.

9.1. Recommendations to research

In order to better assess the risks it appears useful to increase the **quantity** of data, to improve the **quality** of data and to better integrate the several specialities involved. Priorities are listed hereafter.

9.1.1. Increasing the quantity of data

- collect missing data or made available existing data on climate, soils, and first of all on agriculture
- compute and prepare existing data and evaluate their quality
- prepare experiments in order to acquire a minimum of necessary data:
- better validation of crop models notably for important crops studied in this project
- establishment of models for important crops that have not been studied in this project (soy bean, sunflower, grasslands, ...)

9.1.2. Improving the quality of data

- data on physical and chemical features : to continue the inventory of existing data and to make them available on a format suitable for models development, notably climate data (average, extrema, events occurrence), soils and water data (pedologic maps, water table, wells and springs, organic matter contents, gleys, ...),
- data on pesticides : to develop such measurements, in terms of methodology first, because they require specific and expensive devices, and the quantities to measure are frequently near the detection threshold, and in terms of field measurements of concentrations in soil, for that kind of data is missing at the national scale in Romania and Bulgaria.
- data on agriculture and on farming systems : to improve the regional approach and studies on the importance of the main farming systems as presented in this preliminary study, improve the typology through statistical data and a minimum of *in situ* enquiries in order to obtain a better knowledge on the practises (ways of doing) and equipment in the farms such as :
 - current fertilisers use in the main farming systems,
 - current ways of using and recycling organic matter notably animal manure in the different agricultural systems,
 - equipment for collecting, storing, spreading organic matter.

9.1.3. Integrating the existing specialities knowledge and know-how

Notably by coupling data on climate, soil, soil occupation, soil coverage by vegetation, agricultural soils, infrastructures for water control and management,... exploiting existing maps, soil and aerial images (remote sensing, ...) in a kind of *Agro-Geographic Information System* in order to

- detect the acute pollution causes and propose direct remedies: animal manure storage capacity, local losses in sensitive zones, development and optimisation of transferts (translocations) if needed through exchanges of crop residues, organic fertilisers and mineral nutrients...
- better assess the risks of diffuse pollution with the help of models similar to those developed in this study and to improve the recommendations to agriculture as given hereafter.

In that aim the development and application of methods such as

- *improvement of farming practices knowledge and agricultural systems typology*
- *development of "Nutrients balances notably Nitrogen balance" in a limited number of representative farms*

could be recommended as priorities to official agriculture services and to universities or high schools. It is stressed out the necessity to generate national or regional teams by associating various specialists and farming systems generalists.

Attention could be given not only to the current existing situation but also to the probable future situation taking into account the recent orientations met in Romanian and Bulgarian agriculture in the concerned regions. Such studies could be done under the supervision of the local authorities by local scientific teams and with the help of foreign scientific teams with experience in that field in order to spare efforts and to avoid all redundancy and non useful activities.

This also supposes the necessity of integrating these concepts in local scholarship, with university formation devoted to agriculture and environment. This should be done in parallel with the pursuing of know-how transfer, especially concerning models.

9.1.4. Improvement of models

Models have been notably improved in the last years. They integrate soils and crop characteristics with many interdependent different processes. However they greatly depend on a correct calibration, and many other processes could be implemented. The efforts for the development of existing models must go on to forecast still better the risks for environment and facilitate their use, not only by searchers, but also by local deciders.

9.2. Recommendations to agriculture

Despite the limited and incomplete knowledge on agriculture and the limited means in time and money, the authors may propose several first recommendations.

Pollution may occur mainly through leaching with water, horizontal fluxes generally with water fluxes, and atmospheric losses (not taken into account in the current study).

9.2.1. Risks through leaching

Risks through leaching have been assessed as:

- relatively weak for the majority of the area devoted to crop production, important after legumes (soy bean) when soils are not covered in the intercrop season (winter),
- locally important due to the punctual heavy loads in animal husbandry notably in large-sized animal farms,
- locally important due to punctual agricultural practices: over-fertilisation, notably with organic matter, of small acreage familial fields or gardens, uncontrolled access of animal herds to rivers and water springs or dwells.

9.2.2. Risks through surfaces flows

Risks through surfaces flows generate from :

- mineral and organic fertilisation of arable slopes
- large unsown and non tilled land during rainy seasons

9.2.3. Recommendations

- Promote the use of "fertilisation books" for all farms farming more than 30 ha or keeping more than 30 Beef Equivalents, in order to prepare the application of the "Nutrient balance" concept with the help of agricultural advisers.
- Support formation of farmers and agriculture advisers.
- Limit the risks of pollution by pesticides by checking the equipment (sprayers, nozzles,...), defining the economic and ecological way of using pesticides, limiting the doses of pesticides (e.g. triazines to a maximum of 1.5 kg a.i. atrazine per ha and year).
- Check at farm level the existence of sufficient (three to four winter months) animal manure storage capacities and if not, promote such amelioration as a priority.
- Adjust integration between animal production and arable farming including orchards and horticulture and to a better equilibrium between all kinds of activities at the regional level and at the farm level. The risk of excess of manure was pointed out in a scenario with maize fertilised with manure, resulting in a significant leaching of nitrate (Figure 140).

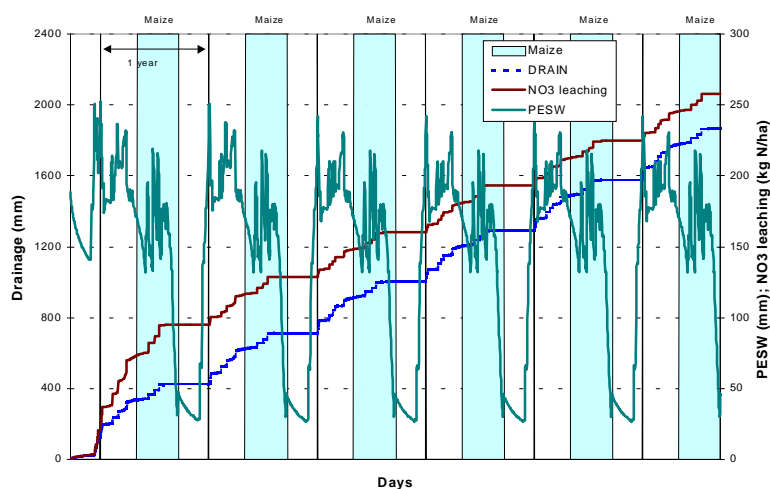

Figure 140: Scenario with manure in autumn and winter (soil of Fundulea, meteo of 1969 -rainy) resulting in important nitrate leaching

- Promote the use and spreading of animal manure in summer-autumn on arable land after "cereals straw ploughed in", on land in pasture or grasses crops, or on land devoted to early sown winter cereals. Indeed, it would reduce or eliminate the risk of winter leaching with high content of nitrogen shown in Figure 140.
- In land devoted to spring crops, allow P fertilisation in autumn, but forbid mineral and organic nitrogen application (to avoid winter nitrate leaching as in Figure 140), promote the incorporation by tillage of the previous crop residues in order to limit erosion and water run-off and to favour soil repletion and "clean-water" leaching for underground water tables repletion.
- Promote on the arable land the drilling of a minimum of 60 % of winter crops that will make good use of water and will limit both the vertical fluxes and the erosion and surface fluxes: winter cereals, winter oil seed rape, temporary fodder crops such as grasses, legumes-grasses associations, ... A scenario in average conditions in Bojurishte with rapeseed as green manure crop neutralised both drainage and nitrate leaching (Figure 141) is given.

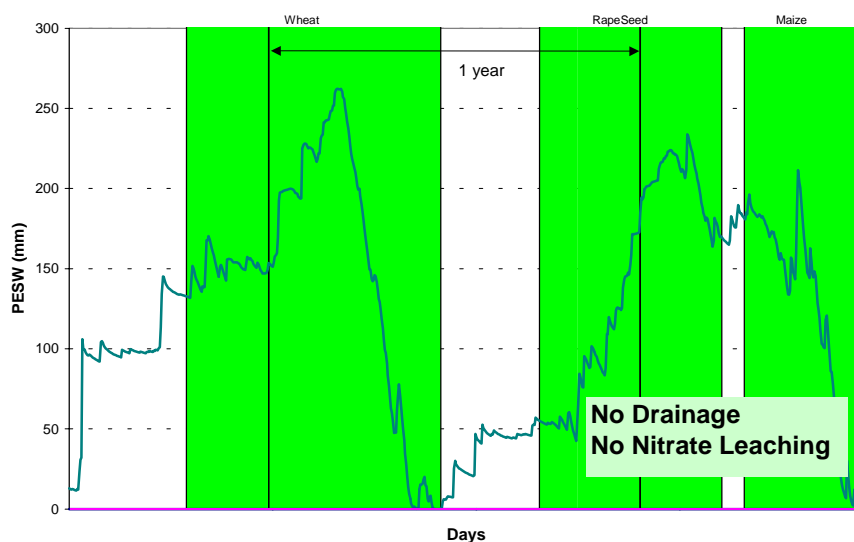

Figure 141: Scenario with rapeseed as green manure in winter (soil of Bojurishte, meteo of 1966 -rainy) resulting in the absence of drainage and nitrate leaching

- As the rainfall compared to ETP is generally low much prudence is recommended in relation to green manure crops development which seems only to be proposed in a limited number of situations. For instance, the scenario in dry conditions in Bojurishte with rapeseed as green manure crop provoked a severe water stress resulting in a crop failure for the maize sown after (Figure 142).

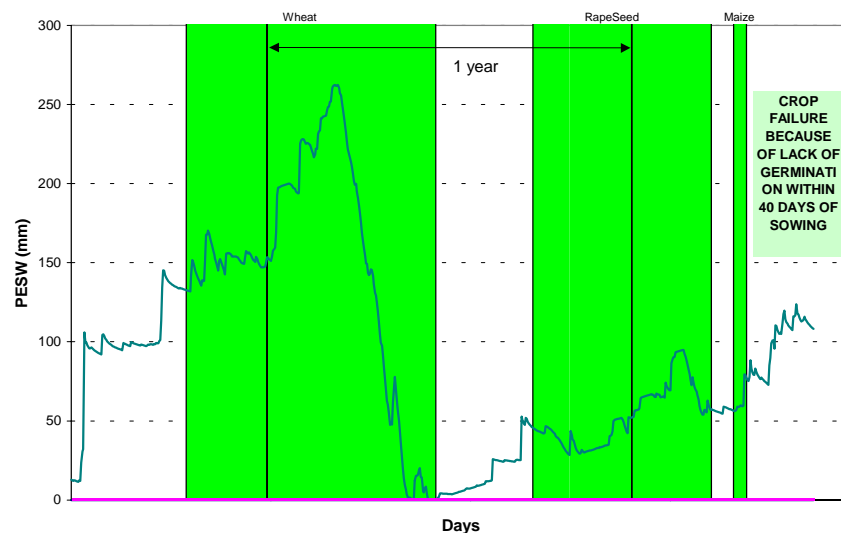

Figure 142: Scenario with rapeseed as green manure in winter (soil of Bojurishte, meteo of 1967 -dry) resulting in severe injury of the following maize

9.3. Perspectives

The simulations have been performed with calibrated and validated soils only, corresponding to the four experimental fields. Therefore the recommendations were somehow limited, but with few efforts they could be extended to other regions in the Danubian plain. It would be interesting, on the basis of our work, to translate characteristics of other soils to perform a similar study and assess risks in other locations. This could be done as a first step with existing data which were collected in the project, or with similar descriptions of soils as those used in Fundulea with older versions of CERES.

Short-term perspectives are the following:

- Improve CERES-Beet (stress, other varieties)
- Add crops (sunflower, pea, ...): we observed the importance of sunflower in cultivated areas, and pea would be a first leguminous crop in our CERES models' family.
- Still improve Soil and Crop components

And long-term perspectives are:

- Other similar projects
 - Where?
 - In other eastern countries,
 - In the Mediterranean basin.
 - Motivations
 - Benefit from this project's experience,
 - Use the specific tools developed.
- Specialisation
 - Scale change from the field to the watershed.

Conclusion

The European Community countries' ecological experience has emphasised the necessity of anticipating all environmental problems, notably regarding diffuse source pollution from agriculture in large-scale farming industry. The nitrogen and pesticides fluxes linked to agricultural productions, and their impact on drinking water quality justify that actions be launched in such zones as the Bulgarian and Romanian plains, which constitute the Danube's watershed, with the Black Sea as outlet. During this EU-PECO collaboration, we have tried to fulfil the two following objectives :

Evaluate and give *ad hoc* recommendations to reduce pollution, mainly due to nitrate leaching, in different agricultural systems of the Danubian plain in Romania and Bulgaria. This objective is based upon the following methodology :

- Fluxes of pollutants per crop have been evaluated from a Atmosphere-Soil-Plant System modelling approach (based on CERES family models). In that view, a first series of experiments has been performed to calibrate the model parameters. The in situ model validation has been performed at two levels : i) a specific series of experiments and ii) a secondary validation with already available data. These models have been designed for wheat, maize, rapeseed and sugar beet and tested on different soil types of Bulgaria and Romania,
- Statistical investigations in order to classify the "typical and actual" situations of the agrosystems in the Danubian plain,
- From these models and statistical data, both a risk evaluation and an identification of sensitive zones have been done in relation with the current agricultural practices. A frequencial analysis based on long-term climatic records was used. It aims at elaborating sustainable agricultural techniques suited to the site-specific characteristics.

Maintain in Romania and Bulgaria the R&D potential in relation with the considered topic « Supply and operation of the tool "modelling of farming impacts on the environment" ». Indeed, the experience of the INRA and of the Agronomic Sciences Faculty of Gembloux in this field have ensured simultaneously the training or the perfecting of the Eastern and Central Europe Countries' researchers and the development of recommendations and environmental-friendly agricultural practices, directly applicable by the farmer.

Concerning the prime objective, and among the most significant results, we can mention the next ones :

CERES-models for maize, wheat and sugar beet have been adapted and calibrated to Romanian and Bulgarian conditions (soil, climate). As by-products of this task, database and friendly user interface for these models have been developed. Models and database are available for the partners of the project, but also for the scientific community, on a CD-Rom and at the following INRA web site :

http://www-egc.grignon.inra.fr/ecobilan/Copernicus/res_inco.html

Moreover, the CERES models developed in this project are compatible with the existing US-CERES models. It gives a larger possibility in terms of utilisation in agriculture.

Investigations of the major agrosystems of the Danubian plain in Romania and Bulgaria have given a clear and up to date overview on the agricultural systems. This action is very crucial and represents clearly an advantage versus official statistics. The main advantage

relies upon a good description of the structure of the farming system (private-collective ; crop with or without animal production) which is a key aspect in term of environment. Moreover, this structure of the farming system is in rapid evolution in these two eastern countries.

Risks evaluation based upon a frequencial analysis applied to the most common scenarios observed in Romania and Bulgaria gives an actual overview of the situation. Among the recommendations, we may underline the following ones :

It exists very sensitive areas, near the Danube, with sandy soils (Dabuleni zone) where the risks are maximum and strategies to avoid pollution are very limited,
More generally, in tchernozem soils, the risks of nitrate leaching are more restricted. The management of the intercrop period with bare soil is the key aspect.
The most crucial question is concerning the relationship between animal production and crop production. We have to avoid a too high concentration of animal production versus the requirements of nitrogen by the crops. On this topic, similar as in EU, the structure of the farming system : family, private or collective (including the size of the farms) is a key question. Environmental evaluation has to be integrated in the evolution of these farming systems.

Nevertheless, this approach has some limitations and we can mention at least the two followings :

We have focused on nitrate leaching pollution, but nitrogen pollution may be due to ammonia and nitrous oxide emissions from manure and mineral fertilisers. We have to avoid a transfer of pollution from soil and water table to the atmosphere. A global approach, as life cycle analysis or nitrogen budget at the farm scale, may be a good complement to this approach.

In our approach, we have focused on time scale characterised by the succession crop1-bare soil- crop2 which is the first priority. We may complement or improve the environmental evaluation through a spatial approach. Water table pollution is the result of an integration of different sources of pollution (fields...) and the spatial arrangement of fields is an other way to limit pollution. This approach requires a local approach based on field and farm description coupled with model leaching approach and an hydrodynamic integration. It may be applied on a restricted number of case studies in the Danubian plain.

The second objective of this project was to maintain in Romania and Bulgaria the R&D potential. This objective has been in very high priority during our project : more than 20 months/scientists from PECO in EU labs (Grignon, Gembloux). This exchange of PECO scientists (3 from Romania and 1 from Bulgaria) has been organised around utilisation of CERES model in a first step and finally on utilisation and development or modification of existing modules. User-friendly interfaces developed in Grignon have been very useful to transfer this know-how to these PECO scientists. Moreover, meetings in Sofia and Bucharest have been opportunities to give lectures to scientists and students of these universities. Nevertheless, transfer of know-how in environment is a crucial aspect which is covering also formation to the farmers or farmer's advisers as the classical method trial-error applied for production is inefficient with environment.

References

1. Bausson J. & Tison J. 1994. Identification des besoins en développement d'exploitations agricoles roumaines. Mémoire INA-PG soutenu le 3 novembre 1994.
2. Biscoe P.V. & Gallagher J.N. 1977. Weather, dry matter production and yield. In: Landsberg J.J. and Cutting C.V. (Eds) *Environmental effects on crop physiology*. London, Academic Press, pp. 75-100.
3. Black J.N. 1956. The influence of seed size and depth of sowing on pre-emergence and early vegetative growth of subterrean clover (*Trifolium subterreanum* L.). *Australian Journal of Agricultural Research* 7:98-109.
4. Boiffin J., Durr C., Fleury A., Marin-Lafèche A. & Maillet I. 1992. Analysis of the variability of sugar beet (*Beta vulgaris* L.) growth during the early stages. I. Influence of various conditions on crop establishment. *Agronomie* 12:515-525.
5. Caneill J., Fleury A. & Ferre F. 1994. L'élaboration du rendement de la betterave sucrière. In: Combe L. and Picard D. (Eds) *Elaboration du rendement des principales cultures annuelles*, INRA, Paris, pp. 143-153.
6. Charles-Edwards D.A., Doley D. & Rimmington G.M. (Eds). 1986. Modelling crop growth and development. Academic Press.
7. Colnenne C., Meynard J.M., Reau R., Justes E. & Merrien A. 1998. Determination of a critical nitrogen dilution curve for winter oilseed rape. *Annals of botany* 81:311-317.
8. Comisia Nationala de Statistica. 1998. Anuarul statistic al Romaniei 1997. Soft -version.
9. Crivineanu C. 1996. Cercetari privind influenta ingrasamintelor asupra productiei si calitatii sfeclei de zahar pe solul brun-roschat din Campia Româna (Recherches sur l'effet des engrais chimiques sur la production et la qualité de la betterave sucrière, sur les sols bruns-rougeâtres de la Plaine Roumaine). Ph D. Thesis. USAMV Bucharest, Romania.
10. Crivineanu C. & Leviel B. 1996. Aspecte privind fertilizarea cu azot din toamna la cultura sfeclei de zahar. Sesiunea stiintifica anuala a cadrelor didactice si a studentilor.
11. Crivineanu C. & Leviel B. 1997. Impact of sugar beet nitrogen fertilization on its quality and on environment. 60è congrès de l'IIRB. Cambridge, July 1997.
12. Damay N. & Le Gouis J. 1993. Radiation use efficiency of sugar beet in Northern France. *European Journal of Agronomy* 2:179-184.
13. Darroch B.A. & Baker R.J. 1990. Grain filling in three spring wheat genotypes: Statistical analysis. *Crop Science* 30:525-529.
14. Davidson J.M., Stone L.R., Nielsen D.R. & Larue M.E. 1969. Field measurements and use of soil-water properties. *Water Resource Research* 5:1312-1321.
15. Diels J. 1994. A validation procedure accounting for model input uncertainty: methodology and application to the swatrer model. Ph D. Thesis. Catholic University of Leuven.
16. Dinchev D. & Badjov K. 1973. Nitrogen balance in agriculture. Bulgarian Academy of Sciences. Sofia, Bulgaria.
17. Doneva E. 1976. Characteristics of soil hydraulic properties and their influence on water balance of cropped soil. Ph D. Thesis. University of civil Engineering. Sofia, Bulgaria.
18. Doorenbos A. & Kassam H. 1979. Yield response to water. Irrigation and Drainage paper 24, FAO, Rome, pp. 101-104.
19. Driessen P.M. 1986. The water balance of soil. In: van Keulen H. and Wolf J. (Eds) *Modelling of agricultural production: Weather, soils and crops*. PUDOC, Wageningen, the Netherlands, pp. 76-116.
20. Driessen P.M. & Dudal R. (Eds). 1991. The major soils of the world. Lecture notes on their geography, formation, properties and use. Agricultural University Wageningen – Katholieke Universiteit Leuven. 310 p.
21. Dudal R. 1965. Dark Clay Soils of Tropical and Subtropical Regions. FAO Agricultural Development Paper Nr 83. FAO, Rome. 161 p.

22. Durand J.-L., Lemaire G., Gosse G. & Chartier M. 1989. Analyse de la conversion de l'énergie solaire en matière sèche par un peuplement de luzerne (*Medicago sativa* L.) soumis à un déficit hydrique. *Agronomie* **9**:599-607.
23. Durr C. 1994. Croissance de la plantule de betterave sucrière (*Beta vulgaris* L.). In: INRA (Ed) *Les Colloques* 67:15-27. Paris, France.
24. Durr C. & Boiffin J. 1995. Sugarbeet seedling growth from germination to first leaf stage. *Journal of Agricultural Science, Cambridge* **124**:427-435.
25. Durr C., Boiffin J., Fleury A. & Coulomb I. 1992. Analysis of the variability of sugar beet (*Beta vulgaris* L.) growth during the early stages. II. Factors influencing seedling size in field conditions. *Agronomie* **12**:527-535.
26. Durr C., Boiffin J., Donne L., Delesalle L. & Badufle B. 1994. Caractérisation de l'aptitude à la levée de différents génotypes de betterave sucrière: étude au champ et en conditions contrôlées. In: INRA (Ed) *Les Colloques* 67:55-64. Paris, France.
27. Durr C., Dubrulle P., Boiffin J., Richard G. & Duval Y. 1995. Mise au point d'un modèle de simulation des levées de la betterave sucrière. 58^e congrès de l'IIRB, Beaune, France, 19-22 June 1995.
28. Duval Y. & Boiffin J. 1990. Influence of soil crusting on the emergence of sugar beet seedlings. In: Scaife A. (Ed) *Proceedings of the 1st Congress of the European Society of Agronomy*, Paris, France.
29. Fick G.W., Loomis R.S. & Williams W.A. 1975. Sugar beet. In: Evans L.T. (Ed) *Crop physiology. Some case histories*. Cambridge University Press, Cambridge, UK, pp. 259-295.
30. Fleury A. & Caneill J. 1984. Croissance et développement de la betterave sucrière - analyse de l'hétérogénéité du peuplement. In: INRA Département d'Agronomie (Ed) *Ecophysiologie de la plante entière*, pp. 201-212.
31. Follett R.F., Keeney D.R. & Cruse R.M. (Eds). 1991. Managing Nitrogen for Groundwater Quality and Farm Profitability. Proceedings of a symposium sponsored by the American Society of Agronomy, the Soil Science Society of America and the Crop Science Society of America, Anaheim, CA, 1988. Soil Science Society of America, Inc. Madison, Wisconsin, USA.
32. Gabrielle B. 1996. Modélisation des cycles des éléments eau-carbone-azote dans un système sol-plante, et application à l'estimation des bilans environnementaux des grandes cultures. Ph D. Thesis. INRA Thiverval-Grignon, France.
33. Gabrielle B. & Kengni L. 1996. Analysis and field-evaluation of the CERES models' soil components: Nitrogen transfer and transformation. *Soil Science Society of America Journal* **60**:142-149.
34. Gabrielle B., Menasseri S. & Houot S. 1995. Analysis and field evaluation of the Ceres models water balance component. *Soil Science Society of America Journal* **59**:1403-1412.
35. Giurov G. & Toshev T. 1990. Soil science. Zemizdat, Sofia, Bulgaria.
36. Godwin D.C. & Jones C.A. 1991. Nitrogen dynamics in soil-plant systems. In: Hanks R.J. and Ritchie J.T. (Eds) *Modelling plant and soil systems*, pp. 287-321. Agron. Monogr. 31. ASA, CSSA and SSSA, Madison, WI.
37. Gosse G., Varlet-Granchet C., Bonhomme R., Chartier M., Allirand J.-M. & Lemaire G. 1986. Production maximale de matière sèche et rayonnement solaire intercepté par un couvert végétal. *Agronomie* **6**:47-56.
38. Gosse G., Cellier P., Denoroy P., Gabrielle B., Laville P., Leviel B., Justes E., Nicolardot B., Mary B., Recous S., Germon J.C., Hénault C. & Leech P.K. 1999. Water, carbon and nitrogen cycling in a rendzina soil cropped with winter oilseed rape: the Châlons Oilseed Rape Database. *Agronomie* **19**:119-124.
39. Greenwood D.J., Lemaire G., Gosse G., Cruz P., Draycott A. & Neeteson J.J. 1990. Decline in percentage N of C3 and C4 crops with increasing plant mass. *Annals of botany* **66**:425-436.
40. Guérif M., Duke C. & Dürr C. 1995. Estimation de la croissance et du rendement de la betterave sucrière: amélioration des performances d'un modèle de simulation par l'utilisation de données de télédétection. Rôle des conditions d'implantation. 58^e congrès de l'IIRB, Beaune, France, 19-22 June 1995.
41. Gummerson R.J. 1986. The effect of constant temperatures and osmotic potentials on the germination of sugar beet. *Journal of Experimental Botany* **37**:729-741.

42. Handbook. 1994. Code de Bonnes Pratiques Agricoles de la Région Wallonne. Cabinet du Ministre de l'Environnement, des Ressources Naturelles et de l'Agriculture pour la Région Wallonne. Comité Nitrates.
43. Hénault C. 1993. Quantification de la dénitrification dans les sols à l'échelle de la parcelle cultivée, à l'aide d'un modèle prévisionnel. Ph D. Thesis. ENSA Montpellier, France.
44. Hénault C., Devroe C., Reau R. & Germon J.C. 1996. Estimation of N₂O fluxes under rape for biological fuel production, bare soil and grass fallow. In: Van Cleemput O., Hoffman G. and Vermoesen A. (Eds) *Progress in Nitrogen Cycling Studies*. Kluwer Academic Publishers (NLD), pp. 559-566.
45. Hoffmann F., Beinhauer R. & Dadoun F. 1993. Soil temperature model for CERES and similar crop models. *Journal of Agronomy and Crop Science* **170**:56-65.
46. Houot S., Cadot L. & Molina J.A.E. 1994. Simulation with the model NCsoil of the temperature and humidity impact on sewage sludge nitrogen evolution in soil. In: Giupponi C., Marani A. and Morari F. (Eds) *Modelling the fate of agrochemicals and fertilizers in the environment*. European Society for Agronomy, Venice, Italy, pp. 273-293.
47. Jensen M. E. (Ed). 1973. Consumptive use of water and irrigation water requirements. Report of Technical Committee of Civil Engineers. Irrigation and Drainage Division. American Society of Civil Engineering, New York.
48. Jones C.A. & Kiniry J.R. (Eds). 1986. CERES-Maize A simulation model of Maize Growth and Development, Texas A&M University Press, College Station.
49. Justes E., Mary B., Meynard J.-M., Machet J.-M. & Thelier-Huches L. 1994. Determination of a critical Nitrogen dilution curve for winter wheat crops. *Annals of botany* **74**:397-407.
50. Kononova M.M. 1963. Organic matter in soils, its nature, properties and methods of investigation. Academy of Science USSR, Moscow.
51. Koynov V., Trashliev C., Yolevsky M., Andonov T., Ninov N., Hadjiyanakiev A., Angelov E., Boyadjiev T., Fotakieva E., Krastanov S. & Staikov Y. 1968. Soil map of Bulgaria, 1/400 000 scale, and accompanying text, Sofia, Bulgaria.
52. Koynov V., Giurov G. & Kolcheva B. 1980. Soil science. Zemizdat, Sofia, Bulgaria.
53. Květ J., Necas J. & Kubín Š. 1966. Measurement of leaf area. Method of studying photosynthetic production of plants. Academia, Pragma, 315-331.
54. Lauer Joseph G. 1997. Sugar beet performance and interactions with planting date, genotype, and harvest date. *Agronomy journal* **89**:469-475.
55. Laurent F. & Eschenbrenner G. 1995. Dynamique de l'azote – L'effet des résidus de culture et du travail du sol. In: *Azote et Interculture*, Perspectives Agricoles n°206, October 1995.
56. Lazar C. 1999. Modelarea cresterii si dezvoltarii la unele plante de cultura (Modelling of growth and development in some crop plants). Ph D. Thesis. University of Bucharest, Romania.
57. Lazar C. & Saulescu N.N. 1996. Dinamica umplerii bobului la zece genotipuri romanesti de grau de toamna. (Grain filling dynamics in ten Romanian winter wheat genotypes). *Probl. genet. teor. aplic.* **28**:69-76.
58. Lemaire G. & Salette J. 1984. Relation entre dynamique de croissance et dynamique de prélèvement d'azote pour un peuplement de graminées fourragères. I. Etude de l'effet du milieu. *Agronomie* **4**:423-430.
59. Leviel B. & Crivineanu C. 2000a. A Leaf Area Index model for sugar beet (*Beta vulgaris* L.) based on leaf-by-leaf development. Submitted.
60. Leviel B. & Crivineanu C. 2000b. A CERES-like crop model for Sugar Beet (*Beta vulgaris* L.). In preparation.
61. Leviel B. & Crivineanu C. 2000c. Characterisation and modelling of stress effects on Leaf Area Index for sugar beet (*Beta vulgaris* L.). In preparation.
62. Loomis R.S. & Nevins D.J. 1963. Interrupted nitrogen nutrition effects on growth, sucrose accumulation and foliar development of the sugar beet plant. *Journal of the A.S.S.B.T.* **12**:309-322.
63. Martin R.J. 1983. Beet cultivar trials in Canterbury. *New Zealand Journal of Experimental Agriculture* **11**:107-112.

64. Martin R.J. 1986. Radiation interception and growth of sugar beet at different sowing dates in Canterbury. *New Zealand Journal of Agricultural Research* **29**:381-390.
65. Martin R.J. & Drewitt E.G. 1984. Effect of sowing date and harvest date on yields of irrigated sugar beet and fodder beet on 2 soil types in Canterbury. *New Zealand Journal of Experimental Agriculture* **12**:185-195.
66. Mehandjieva A. 1974. Irrigation scheduling of alfalfa for the region of Sofia irrigation system. Ph D. Thesis. Institute of Irrigation and Drainage, Sofia, Bulgaria.
67. Meisinger J.J. & Randall G.W. 1991. Estimating Nitrogen Budgets for Soil-Crop Systems. In: Follett R.F., Keeney D.R. and Cruse R.M. (Eds) *Managing Nitrogen for Groundwater Quality and Farm Profitability*. Proceedings of a symposium sponsored by the American Society of Agronomy, the Soil Science Society of America and the Crop Science Society of America, Anaheim, CA, 1988. Soil Science Society of America, Inc. Madison, Wisconsin, USA.
68. Meteorological annual references. 1960-1980. Hydrometeorological service, Sofia, Bulgaria.
69. Milford G.F.J. 1973. The growth and development of the storage root of sugar beet. *Annals of Applied Biology* **75**:427-438.
70. Milford G.F.J., Biscoe P.V., Jaggard K.W., Scott R.K. & Draycott A.P. 1980. Physiological potential for increasing yields of sugar beet. In: Hurd R.G., Biscoe P.V. and Dennis C. (Eds) *Opportunities for increasing yields of sugar beet*. London, Pitman, pp. 71-83.
71. Milford G.F.J., Pocock T.O. & Riley J. 1985a. An analysis of leaf growth in sugar beet. I. Leaf appearance and expansion in relation to temperature under controlled conditions. *Annals of Applied Biology* **106**:163-172.
72. Milford G.F.J., Pocock T.O. & Riley J. 1985b. An analysis of leaf growth in sugar beet. II. Leaf appearance in field crops. *Annals of Applied Biology* **106**:173-185.
73. Milford G.F.J., Pocock T.O., Riley J. & Messem A.B. 1985c. An analysis of leaf growth in sugar beet. III. Leaf expansion in field crops. *Annals of Applied Biology* **106**:187-203.
74. Milford G.F.J., Pocock T.O., Jaggard K.W., Biscoe P.V., Armstrong M.J., Last P.J. & Goodman P.J. 1985d. An analysis of leaf growth in sugar beet. IV. The expansion of the leaf canopy in relation to temperature and nitrogen. *Annals of Applied Biology* **107**:335-347.
75. Milford G.F.J., Travis K.Z., Pocock T.O., Jaggard K.W. & Day W. 1988. Growth and dry matter partitioning in sugar beet. *Journal of Agricultural Science, Cambridge* **110**:301-308.
76. Molina J.A.E., Clapp C.E., Shaffer M.J., Chichester F.W. & Larson W.E. 1983. NCSOIL, a model of nitrogen and carbon transformations in soil: description, calibration and behavior. *Soil Science Society of America Journal* **47**:85-91.
77. Monteith J.L. 1977. Climate and the efficiency of crop production in Britain. *Phil. Trans. R. Soc. London B.* **281**:277-294.
78. Nevins D.J. & Loomis R.S. 1970. Nitrogen nutrition and photosynthesis in sugar beet. *Crop Science* **10**:21-25.
79. Nicolardot B. & Molina J.A.E. 1994. C and N fluxes between pools of soil organic matter: model calibration with long-term field experimental data. *Soil biology and biochemistry* **26**:245-251.
80. Pang X.P., Gupta S.C., Moncrief J.F., Rosen C.J. & Cheng H.H. 1998. Evaluation of nitrate leaching potential in Minnesota glacial outwash soils using the CERES-Maize model. *J. Environ. Qual.* **27**:75-85.
81. Patefield W.M. & Austin R.B. 1971. A model for the simulation of the growth of *Beta vulgaris* L. *Annals of Botany* **35**:1227-1250.
82. Penkov M., Doynov V. & Bojadjev T. 1992. Classification and Diagnostics of the soils in Bulgaria in the context of land regulation. Zemizdat, Sofia, Bulgaria.
83. Persson J.A. 1996. Handbook of Kjeldal. Method Digest. Tecator AB.
84. Plenet D. 1995. Fonctionnement des cultures de maïs sous contrainte azotée. Détermination et application d'un indice de nutrition. Ph D. Thesis. Institut National Polytechnique de Lorraine, Nancy, France.

85. Popova Z. & Feyen J. 1996. Adjustment of WAVE model Kc-factors for Bulgarian weather conditions. In: *Selected papers of the workshop "Crop-Water-Environment models"*, ICID congress, Cairo, pp. 176-186.
86. Popova Z., Leviel B., Kercheva M., Varlev I. & Gosse G. 1999. Linking water in N-dynamics of cropped soil into risk of ground water pollution. In: Musy A., Pereira L.S. and Fritsch M. (Eds) *Proceedings of 2nd Inter-Regional Conference on Environment-Water "Emerging Technologies for Sustainable Land Use and Water Management"*, 1-3 Sept. 1999, PPUR, Lausanne, Switzerland.
87. Radenkova-Karaivanova M. 1964. Study on the fertilizer application under smolnitsa conditions. *Bulgarian Academy of Sciences*, Sofia, Bulgaria.
88. Raes D., van Aelst P. & Wyseure G. 1986. ETREF, ETCROP, ETSPLI T, DEFICIT - a computer package for calculating crop water requirements. Ref.manual, 1986.
89. Recous S. 1995. Incorporation des résidus végétaux – Quel effet sur la dynamique de l'azote? In: *Azote et Interculture*, Perspectives Agricoles n°206, October 1995.
90. Richard G. & Guéris J. 1988. Modélisation des transferts gazeux dans le lit de semences: application au diagnostic des conditions d'hypoxie des semences de betterave sucrière (*Beta vulgaris* L.) pendant la germination. I. Présentation du modèle. *Agronomie* **8**:539-547.
91. Ritchie J.T. 1972. Model for predicting evaporation from a row crop with incomplete cover. *Water Resources Research* **8**:1204-1213.
92. Scott R.K. & Jaggard K.W. 1978. Theoretical criteria for maximum yield. In: *Proceedings of the 41st Winter Congress of the International Institute of Sugar Beet Research*, Brussels, pp. 179-198.
93. Scott R.K., English S.D., Wood D.W. & Unsworth M.H. 1973. The yield of sugar beet in relation to weather and length of growing season. *Journal of Agricultural Science, Cambridge* **81**:339-347.
94. Scott R.K., Harper F., Wood D.W. & Jaggard K.W. 1974. Effects of seed size on growth, development and yield of monogerm sugar beet. *Journal of Agricultural Science, Cambridge* **82**:517-530.
95. Slavov N. 1984. Agrometeorological conditions for modeling of maize productivity process and mapping. In: Tomov N. and Yordanov Y. (Eds) *Maize in Bulgaria*. Zemizdat, Sofia, Bulgaria, pp. 113-130.
96. Smith M. 1992. CROPWAT- a computer program for irrigation planning and management. Irrigation and Drainage paper 46, FAO, Rome, 1992.
97. Snyder F.W. & Carlson G.E. 1978. Photosynthate partitioning in sugarbeet. *Crop Science* **18**:657-661.
98. Soltner D. 1990. Les bases de la production végétale – Tome I: Le sol. Collection sciences et techniques agricoles. 18^e édition.
99. Soltner D. 1999. Les grandes cultures végétales – Phytotechnie spéciale. Collection sciences et techniques agricoles. 19^e édition.
100. Tamet V., Durr C. & Boiffin J. 1994. Croissance des plantules de carotte de la germination jusqu'à l'apparition des premières feuilles. *Acta Horticulturae* **354**:17-25.
101. Ulrich A. 1952. Physiological bases for assessing the nutritional requirements of plants. *Annual Review of Plant Physiology* **3**:207-228.
102. Vardon F. 1993. Adaptation d'un modèle dynamique de simulation de colza d'hiver (FIL) à un modèle de culture gérant l'eau et l'azote (CERES), validation et analyse de sensibilité. Master of Sci. Report, ENSAR, INRA Bioclimatologie Grignon, France.
103. Vereecken H. 1988. Pedotransfer function for the generation of hydraulic properties for Belgian soils. Ph D. Thesis, Faculty of Agronomic Science, K.U.Leuven, Belgium.
104. Vereecken H., Maes J., Feyen J. & Darius P. 1989. Estimating the soil moisture retention characteristic from texture, bulk density and carbon content. *Soil Science* **148**:389-403.
105. Webb C.R., Werker A.R. & Gilligan C.A. 1997. Modelling the dynamical components of the sugar beet crop. *Annals of botany* **80**:427-436.
106. Ziegler D. & Heduit M. 1991. Engrais de ferme. Valeur fertilisante – Gestion - Environnement. Edition 1991. ITCF – ITP – ITEB.

Index of Figures

Figure 1: The Danube River through Europe.....	8
Figure 2: The Danube River from Budapest to Constanta.....	9
Figure 3: Excel Data Base for sugar beet data	16
Figure 4: Interface for the use of CERES models.....	17
Figure 5: Illustration of a result of a 1to1 graph during calibration.....	17
Figure 6: Interface for simulation of crop rotations	18
Figure 7: The global Copernicus project. The dark boxes represent the contributions of the thesis in the project. The light boxes are Belgian and eastern countries contributions....	19
Figure 8 : Overview of existing models (from Gabrielle, personal communication)	21
Figure 9: Temperature and rainfall of the experimental season in Bucharest compared to 25-year average.....	33
Figure 10: Optimisation of Temperature base with LAI data sets from literature.....	33
Figure 11: Validation of the leaf area measurement method.	34
Figure 12: Area dynamics of leaf <i>i</i>	35
Figure 13: Temperature and rainfall of the experimental season in Grignon compared to 12-year average.....	36
Figure 14: Comparison of the <i>LAI</i> calculated with the measurements of all leaves to the <i>LAI</i> calculated from the measurements of 1 leaf out of 5. Each point represent one of the 36 monitored plants on the 27 th July 1998.	37
Figure 15: Leaf-appearance rate of all treatments as a function of growing degree days ($T_b=3$ °C).....	37
Figure 16: Leaves maximum areas observed for the six treatments. <i>irr</i> stands for irrigated and <i>dry</i> for non irrigated.	38
Figure 17: Measurements of leaves maximum areas in potential conditions and illustration of the model deduced.....	39
Figure 18: Measurements and estimation of the leaf growth duration	40
Figure 19: Measurements of leaves life duration and illustration of the model deduced.	40
Figure 20: Measured <i>LAI</i> dynamics of the Bucharest experiment compared to the model results. Each row corresponds to a level of fertilisation (300, 150 and 0N), the first column is with irrigation, the others are without irrigation and with 5 and 7 parameters, resp.	42
Figure 21: Measured <i>LAI</i> dynamics of the Grignon experiment compared to the model results. The first column presents the simulations with irrigation, and the first row with fertilisation.	44
Figure 22: Different effects of changes in the model parameters for a leaf.....	46
Figure 23: <i>LAI</i> dynamics of the four treatments in Grignon in 1998	48
Figure 24: Dry matter of the four treatments in Grignon, and repartition.....	48
Figure 25: Dry Matter partitioning.....	49
Figure 26: Replicates of sugar content of Roots (% Fresh Matter).....	49
Figure 27: Nitrogen contents in the sugar beet compartments.....	49
Figure 28: Comparison of model outputs and experimental results for potential conditions in Bucharest.....	50
Figure 29: Modelling general background.....	51
Figure 30: CERES execution control panel	63
Figure 31: Internet download page for CERES codes and associated tools	63
Figure 32: Editor for CERES parameters files.....	64
Figure 33: Software converting meteo data from Excel to CERES format	65
Figure 34: CERES output as text	66

Figure 35: CERES output imported in Excel	66
Figure 36: Experimental data collection for comparison to CERES simulation.....	67
Figure 37: CERES output converted in an Excel graph, with comparison to field data	67
Figure 38: Linear regression from comparison of field and simulated soil water contents	68
Figure 39: Rotation control panel.....	69
Figure 40: Common structure of parameters files, whatever the crop	70
Figure 41: Output control of auto-irrigation	70
Figure 42: Some profiles of evolution of N-NO ₃ in mg/kg soil for 200 kg/ha of nitrogen supply, Bojurishte 1998.....	74
Figure 43: Calibration of WRC/WCC parameters on the basis of laboratory measurements..	75
Figure 44: Measured and simulated Water and Nitrate contents of three out of five layers for “N200” treatment in Bojurishte, 1997. Black lines are simulations, squares are measurements. For water contents, the three points at the beginning represent, from bottom to up, wilting point, field capacity and saturation.....	75
Figure 45: Simulated with measured time series of WC and PESW for the plots in Bojurishte for the experimental year of calibration	76
Figure 46: Comparison of model predictions for wheat dry matter with measured ones under fertilised and non-fertilised conditions.....	77
Figure 47: Measured and simulated water and nitrate contents of three layers for fertilised treatment Bojurishte, 1998. Black lines are simulations, squares are measurements. For water contents, the three points at the beginning represent, from bottom to up, wilting point, field capacity and saturation.....	78
Figure 48: Model predictions for two sets of crop parameters and measurements of wheat dry matter for fertilised treatment in Bojurishte, 1998.	79
Figure 49. Drainage vs. P(%) for wheat vegetation	80
Figure 50. N-leaching vs. P(%) for wheat vegetation	80
Figure 51. Drainage vs. P(%) for post-vegetation period.....	80
Figure 52. N-leaching vs. P(%)for post-vegetation period	80
Figure 53: Some profiles of evolution of N-NO ₃ in mg/kg soil at dry and irrigated treatment for 200 kg/ha of nitrogen supply	82
Figure 54: N-content of plant components over DOY (Day of the year) for the optimal treatment in Chelopechene, 1997	83
Figure 55: Comparison of total N-uptake for the irrigated treatments in Chelopechene, 1997	83
Figure 56: Adjustment of laboratory WRC to field measurements	84
Figure 57: Measured and simulated Water and Nitrate contents of three layers in lysimeters, Chelopechene, 1997. Black lines are simulations, squares are measurements (replicates if linked). For water contents, the four points at the beginning represent, from bottom to up, wilting point, field capacity, initial value and saturation.	86
Figure 58: Simulated (triangles) and measured (interrupted line) EvapoTranspiration with optimum irrigation and fertilisation, Chelopechene, Lysimeter, 1997	87
Figure 59: Simulated (narrow line) and measured (broad line) cumulative drainage, and daily precipitation+irrigation, Chelopechene, Lysimeter, 1997.....	87
Figure 60: Measured and simulated water and nitrate content for three layers in irrigated field plots, Chelopechene, 1997.	88
Figure 61: Measured and simulated water and nitrate contents of three layers for dryland plots in Chelopechene, 1997.	89
Figure 62. Drainage & evapotranspiration vs. P(%) for maize vegetation	91
Figure 63. N-leaching vs. P(%)for maize vegetation	91
Figure 64. Drainage vs. P(%) for fallow state of the field	91
Figure 65. N-leaching vs. P(%)for fallow state of the field	91

Figure 66 Influence of nitrogen fertilisation on nitrogen content of leaves in winter wheat (Fundulea 1998)	93
Figure 67: Influence of nitrogen fertilisation on nitrogen content of stems in winter wheat (Fundulea 1998)	93
Figure 68: Observed (squares) and simulated (continuous line) volumetric water content (%) in soil layer 5 vs. number of days after beginning of simulation (1-Jan-1996) –Winter wheat, irrigated and fertilised with 100 kg N/ha - Fundulea 1996-1997	94
Figure 69: Observed (squares) and simulated (continuous line) nitrate content (kg N/ha) in soil layer 5 vs. number of days after beginning of simulation (1-Jan-1996) –Winter wheat, irrigated and fertilised with 100 kg N/ha - Fundulea 1996-1997	94
Figure 70: Observed (squares) and simulated (continuous line) DM in plant organs (g/m ²) vs. number of days after beginning of simulation (1-Jan-1996) –Calibration data set: Winter wheat, irrigated and fertilised with 100 kg N/ha - Fundulea 1996-1997	95
Figure 71: Simulated vs. measured soil water (%). Winter wheat, irrigated, herbicided and fertilised with 100 kg N/ha - Fundulea 1997-1998	95
Figure 72: Observed (squares) and simulated (continuous line) DM in plant organs (g/m ²) vs. number of days after beginning of simulation (1-Jan-1997) –Validation file: Winter wheat, irrigated and fertilised with 100 kg N/ha - Fundulea 1997-1998	96
Figure 73: Model drainage and nitrate leaching in relation to probability of exceedance of cumulated rainfalls for the winter wheat vegetation period (15 September-15 July)	97
Figure 74: Model drainage and nitrate leaching in relation to probability of exceedance of cumulated rainfalls for the bare soil period after winter wheat crop (16 July-14 September)	97
Figure 75: Final dry matter accumulated in maize leaves (Fundulea 1997-1998).....	98
Figure 76: Final dry matter accumulated in maize kernels (Fundulea 1997-1998)	99
Figure 77: Measured versus simulated values for soil water (left) and potential extractable soil water (right) for the maize plots irrigated, herbicided and fertilised with 200 kg N/ha. 100	
Figure 78: Dynamics of measured (squares) and simulated (continuous line) values for volumetric soil water content [%] (left) and nitrate soil content [kg N/ha](right) for the maize plots irrigated and fertilised with 200 kg N/ha (Fundulea 1997).....	100
Figure 79: Dynamics of measured (squares) and simulated (continuous line) values for volumetric soil water content [%] for the maize plots irrigated and fertilised with 200 kg N/ha (Fundulea 1998).....	101
Figure 80: Relationship between simulated and observed PESW for maize crop (Fundulea, 1997 and 1998).....	101
Figure 81: Model drainage and nitrate leaching in relation to probability of exceedance of cumulated rainfalls for the maize vegetation period (April-September).....	103
Figure 82: Model drainage and nitrate leaching in relation to probability of exceedance of cumulated rainfalls for the bare soil period after maize crop (September-April)	103
Figure 83: Dry Matter and extractable sugar.....	106
Figure 84: Dilution curves.....	107
Figure 85 Simulated and observed Potentially Extractable Soil Water in the profile in 1997, with (left) and without (right) irrigation.....	108
Figure 86 LAI and number of leaves experimental and simulated data for 1997 (calibration) and 1998 (validation)	108
Figure 87 Dry matter experimental and simulated data for 1997 (calibration) and 1998 (validation)	109
Figure 88 Model drainage and nitrate leaching in relation to probability of exceedance of rainfall totals for the vegetation period	110

Figure 89 Modelled drainage and nitrate leaching in relation to probability of exceedance of rainfall totals for the intercultural period	111
Figure 90: Access page to the COPERNICUS data branchings	112
Figure 91: Maize branchings with hypertext access to data files.....	112
Figure 92: Extract of the COPERNICUS Project DataBase	113
Figure 93 : Risks analysis for the current farming systems – diagram of reflexion.....	114
Figure 94 : Soil Map in Romania, main rivers and counties in Danube plain (better resolution in Appendix A).....	115
Figure 95 : Major soils in Romania (>200 millions ha).....	115
Figure 96 : Major soils of Romanian Danube watershed (% are estimation)	116
Figure 97 : Occurrence of rainfall events and averaged monthly sums of rainfall for Caracal station (OLT).....	120
Figure 98 : Analysis of national statistical data : major crops and animals for OLT county.	121
Figure 99 : Typology of farms with animals.....	122
Figure 100 : Typology of farms without livestock.....	123
Figure 101 : Current agricultural practices for Winter-wheat monoculture.....	124
Figure 102 : Current agricultural practices for Maize monoculture.....	124
Figure 103 : Current agricultural practices for Sugar beet and Sunflower rotation.....	125
Figure 104 : Danube plain in Bulgaria, location of PLEVEN and OBRASTZOV CHIFLIK stations (better resolution in Appendix A)	125
Figure 105 : Soil types in Bulgarian Danube watershed (FAO classification)	126
Figure 106 : Average, absolute maximum and minimum of rainfall calculated on a 20 years period for PLEVEN station	127
Figure 107 : Occurrence of rainfall events (by month and for 2 consecutive months) for PLEVEN station.....	128
Figure 108 : Average, absolute maximum and minimum of rainfall calculated on a 20 years period for OBRASTZOV CHIFLIK station.....	128
Figure 109 : Occurrence of rainfall events (by month and for 2 consecutive months) for OBRASTZOV CHIFLIK station	129
Figure 110 : Agricultural lands distribution in Bulgaria.....	130
Figure 111 : Main crops cultivated by households in 1995 in Bulgarian Danube watershed	130
Figure 112 : Main crops cultivated in associations in 1995.....	131
Figure 113 : Main crops scheduling	131
Figure 114 : Livestock in Bulgarian in 1995.....	132
Figure 115 : Risk analysis scheme	133
Figure 116 : Monthly deficit in water in Calarasi county (calculated using averaged monthly sums of rainfall, temperature and global radiation)	137
Figure 117 : Monthly deficit in water in Calarasi county (calculated using monthly sums of extreme rainfall with occurrence of 9% and 19% and monthly temperature and global radiation of years corresponding to extreme rainfalls).....	137
Figure 118 : Mixed farms with production intended to auto-consumption (E1) : farming system analysis	140
Figure 119 : Soil nitrogen content increase under Fundulea climate of 1975.....	142
Figure 120 : Modelling of maize monoculture under Fundulea climate : nitrogen balance ..	142
Figure 121 : Plots distribution in a sunflower-wheat-wheat-maize-maize rotation in C2 structures	143
Figure 122 : Crops rotation (dates and cover) on a particular plot	143
Figure 123 : Family associations, phytotechnical farms (C2) : farming system analysis	145
Figure 124 : Soil water content, cumulated drainage and leaching under Fundulea climate of 1975 – Sunflower-wheat-wheat-maize-maize rotation	147

Figure 125 : Soil water content, cumulated drainage and leaching under Fundulea climate of 1969 – Sunflower-wheat-wheat-maize-maize rotation	147
Figure 126 : Manure production by livestock in E4 system	148
Figure 127 : Crops rotation in trading societies with cattle (E4) – agricultural area : 1000 ha	149
Figure 128 : Trading societies with cattle (E4) : R1, R2 and R3 rotations : N balance	150
Figure 129 : Trading societies with cattle (E4) : R4 and R5 rotations : N balance.....	151
Figure 130 : Soil water content, cumulated drainage and leaching under Fundulea climate of 1975 – Sunflower-wheat-sugar beet-wheat rotation	153
Figure 131 : Monthly deficit in water in PLEVEN (left) and OBRASTZOV (right) stations (calculated using averaged monthly sums of rainfall, temperature and global radiation) – 20 years of data	155
Figure 132 : Monthly deficit in water in PLEVEN (left) and OBRASTZOV (right) stations (calculated using monthly sums of extreme rainfall with occurrence of 10% and monthly temperature and global radiation of years corresponding to extreme rainfalls).....	156
Figure 133 : Family farms with livestock and crops in Bulgaria	157
Figure 134 : Crops succession on a particular plot as simulated (with CERES models) under Bulgarian climate – phytotechnical co-operatives	158
Figure 135 : Soil water content, cumulated drainage and leaching under Pleven climate of 1971 and with soil characteristics of Chelopechene – Sunflower-wheat-wheat-maize-maize rotation.....	159
Figure 136 Software interface to simulate consecutive years with the same soil parameters and extract specific results, such as Yield, Drainage and N leaching.....	160
Figure 137: Cumulative probabilities of maize grain yield as a function of 5 fertiliser application rates with and without irrigation.....	160
Figure 138 Cumulative probabilities of drainage as a function of 5 fertiliser application rates with and without irrigation	161
Figure 139 Cumulative probabilities of Nitrate leaching as a function of 5 fertiliser application rates with and without irrigation	161
Figure 140: Scenario with manure in autumn and winter (soil of Fundulea, meteo of 1969 - rainy) resulting in important nitrate leaching	164
Figure 141: Scenario with rapeseed as green manure in winter (soil of Bojurishte, meteo of 1966 -rainy) resulting in the absence of drainage and nitrate leaching.....	165
Figure 142: Scenario with rapeseed as green manure in winter (soil of Bojurishte, meteo of 1967 -dry) resulting in severe injury of the following maize.....	166

Index of Tables

Table 1: Parameters for the Bucharest's experiments and results expressed as mean square error (MSE) or mean error. Mean error ₂ is the mean error calculated without the three first dates (early development). Dark lines are the true parameters (5 or 7), white lines are constant parameters, independent of fertilisation and irrigation.	43
Table 2: Parameters for the Grignon experiments and results expressed as mean square error (MSE) or mean error. Mean error ₂ is the mean error calculated without the three first dates (early development). Dark lines are the true parameters, white lines are constant parameters, independent of fertilisation and irrigation.	45
Table 3: Indicative values of γ for various soil texture classes (Driessen, 1986)	59
Table 4: Glossary of variables.....	61
Table 5: Deep percolation and N-NO ₃ load at the two-meter depth	83
Table 6: Linear regressions for simulated vs. observed soil nitrate (kg N/ha) in different experimental plots (data from all layers).....	102
Table 7: Linear regressions for simulated vs. observed soil nitrate (kg N/ha) in different layers (data from all experimental plots, 48 observations for each layer)	102
Table 8: Linear regressions for simulated vs. observed dry matter accumulation in different organs and leaf area index (LAI).....	102
Table 9: Linear regressions for cumulated drainage (mm) during maize vegetation period as variable X and nitrate leaching (kg N/ha) as variable Y	104
Table 10: Linear regressions for cumulated drainage (mm) for the bare soil period after maize crop as variable X and nitrate leaching (kg N/ha) as variable Y	104
Table 11: Synthesis of simulation for the growth period	111
Table 12: Data files codification	112

Index of appendices

APPENDIX A Romanian and Bulgarian soil maps

National Data of Romania

APPENDIX B Characteristics of major soils

APPENDIX C Available climate data “on 27th of July” (Rainfall and temperatures)

APPENDIX D Occurrence of Rainfall events : frequential analysis for each county

APPENDIX E Major crops and animals by county

National Data of Bulgaria

APPENDIX F Characteristics of soils around PLEVEN

APPENDIX G Results of simulations

APPENDIX H Pollution of the Black Sea

APPENDIX I Scientific paper on Water and Nitrogen Budgets

APPENDIX A

Romanian and Bulgarian soil maps

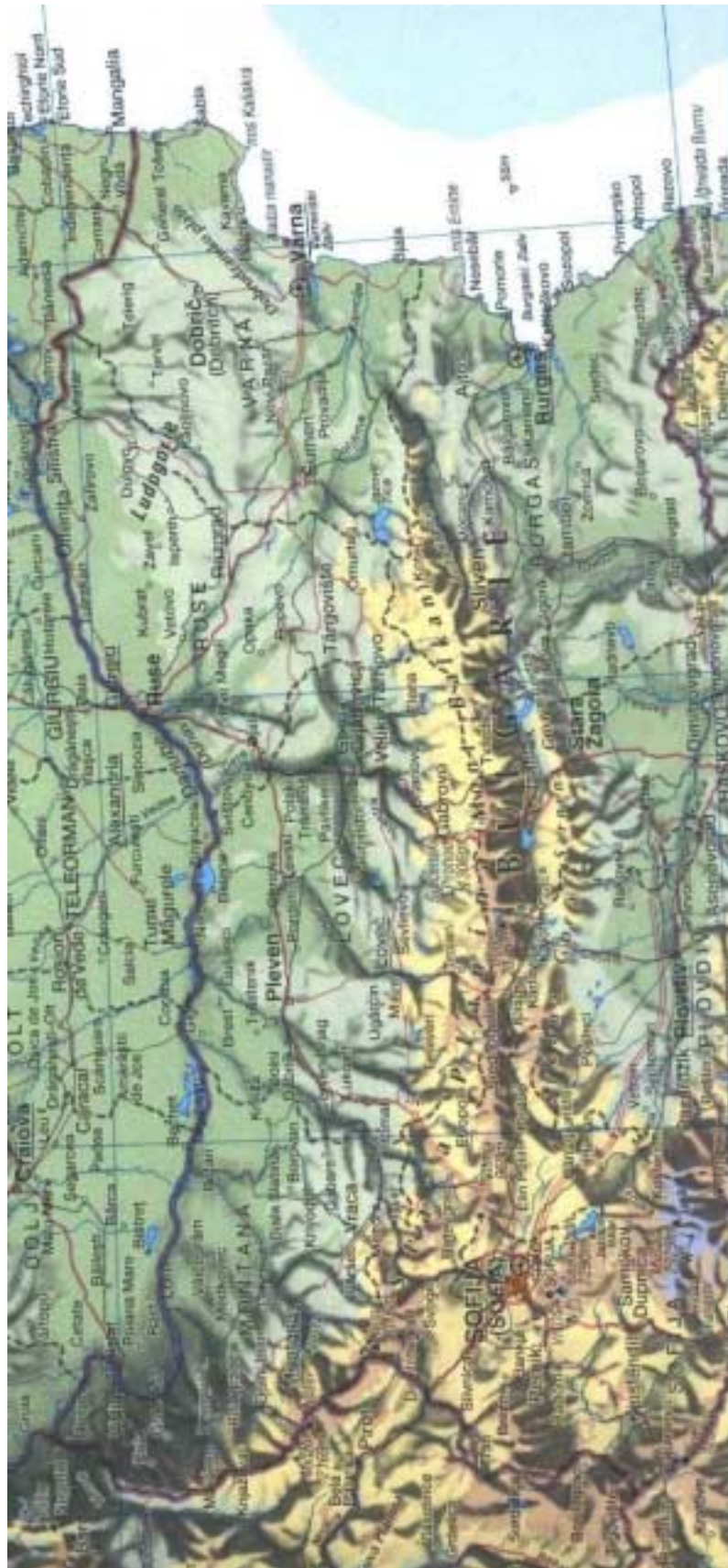

APPENDIX B

Characteristics of major soils in Romania

Characteristics of major soils in Romania

LUVISOLS (brown-reddish)

Horizon	Ap	Ao	A/B	Bt	Bt	Bt
Depth (cm)	0-20	20-32	32-49	49-75	75-110	110-170
Clay (< 0.002 mm)	24	27.7	32.3	37.7	38.2	37.6
0.002 < % < 0.02 mm	36.4	36.1	30.1	28.7	33	31.7
0.02 < % < 0.2 mm	30.8	27.9	18.4	19.5	22	25.5
0.2 < % < 2 mm	0	0	0	0	0	0
DA (g/cm ³)	1.38	1.50	1.54	1.58	1.63	1.64
WP (%)	8.3	9.8	10.9	11.9	11.7	10.1
FC (%)	23.9	23.4	22.	21.9	20.7	20
Total porosity (%)	47.9	43.3	42.1	41	39.1	39.2
Ksat (mm/h)	4	0.9	0.4	0.2	0.2	0.1
Humus	1.5	1	0.6	0.6		
N (%)	0.098	0.088	0.070	0.074	0.048	0.046
PH	6.5	6.6	6.9	6.7	6.6	6.6
C/N	10.3	7.7	5.8	5.5	8.4	7.3

FLUVISOLS (alluvial soils)

Horizon	Ap _{sc}	C _{sc}	C _{sc}	C _{sc}	C	C
Depth (cm)	0-24	24-41	41-55	55-70	70-100	100-150
Clay (< 0.002 mm)	30.8	22.3	9.6	12.7	11.4	15.3
0.002 < % < 0.02 mm	27.8	27.3	33	32.4	29.5	35.7
0.02 < % < 0.2 mm	31.7	30.7	28.2	16	5.4	4.5
0.2 < % < 2 mm	1	0.9	0.3	0.2	0	0
DA (g/cm ³)	0.83	1.14	1.21	1.28	1.31	1.32
WP (%)	18.6	7.8	3.3	5.4	4.7	5.7
FC (%)	31.5	25.5	19.1	19.5	19.1	19.4
Total porosity (%)	67.3	57.4	55	52.4	51.3	50.9
Ksat (mm/h)	49	43	37.5	16.1	16.3	20.7
Humus	12.3	1.7	0.6	0.7	0.7	0.7
N (%)	0.576	0.102	0.580			
PH	7.4	8	8.1	10.8	11.8	11.6
C/N	14.4	11.3	0.7			

CHERNOZEMS

Horizon	Ap1	Ap2	A/B	BV1	BV2	Cca
Depth (cm)	0-19	19-29	42-58	58-77	77-100	
Clay (< 0.002 mm)	27.5	28.1	28.3	23.8	22.7	18.7
0.002 < % < 0.02 mm	33.1	34.2	33.8	32.1	31.5	35
0.02 < % < 0.2 mm	28.1	28	26.2	28.1	29.8	29.7
0.2 < % < 2 mm	0	0	0	0	0	0
DA (g/cm ³)	1.10	1.27	1.35	1.36	1.34	1.30
WP (%)	11	11.4	12.2	9.3	8.3	6.9
FC (%)	26.6	25.1	21.3	22.7	21.8	19.7
Total porosity (%)	58.4	52	49.6	49.6	50.3	51.8
Ksat (mm/h)	37.2	11.5	38.2	15.9	14.9	9.2
Humus	3.4	3.3	1.5	1.2	0.8	0.9
N (%)	0.173	0.165	0.189	0.08	0.07	0.05
PH	7.9	6.7	7.1	8.2	7.9	8.4
C/N	14.3	14.5	14.2	14.4		

ARENOSOLS (sandy deposit)

Horizon	A0	Ac	C	Af	Ea
Depth (cm)	0-10	10-30	30-65	65-100	100-155
Clay (< 0.002 mm)	3.4	0.4	1.5	0.9	1.2
0.002 < % < 0.02 mm	1.2	1		1	1.4
0.02 < % < 0.2 mm	86.2	87		87.7	87.3
0.2 < % < 2 mm	8.2	8.6		6.5	7.3
DA (g/cm ³)	1.12	1.4	1.44	1.4	
WP (%)	2	0.6	0.8	0.6	
FC (%)	6	4.1	5.3	5.2	
Total porosity (%)	59	49	49	49	
Ksat (mm/h)	91.9	160.3	180.8	183.6	
Humus	1.51	0.25	0.24	0.33	0.18
N (%)	0.077	0.041	0.023	0.020	0.012
PH	4.7	5.45	6.35	6.2	7

PODZOLS

Horizon	Ap	E1	EB	Bt1	Bt2	Bt3
Depth (cm)	0-25	25-35	35-50	50-70	70-100	100-150
Clay (< 0.002 mm)	21	20.4	25.1	39	36	33.7
0.002 < % < 0.02 mm	36.7	35.2	35.4	30.6	27.6	27.3
0.02 < % < 0.2 mm	26.2	27.8	22.3	17.3	15.3	15.5
0.2 < % < 2 mm	11.5	10	11.4	7.5	4.3	3.7
DA (g/cm ³)	1.14	1.46	1.50	1.54	1.59	1.61
WP (%)	6.3	5.8	8.1	14.5	13	12.1
FC (%)	27.4	24.3	21.4	22.2	22.7	22
Total porosity (%)	58	46	44	43	41	41
Ksat (mm/h)	26.8	6.9	1.5	0.4	0.4	0.3
Humus	1.41	0.73	0.46	0.37		
N (%)	0.16	0.12	0.10			
PH	5.19	5.31	5.56	5.70	5.92	6.06

APPENDIX C

Available climate data on 27th of July
(Rainfall and temperatures).

Available climate data on 27th of July (Rainfall and temperatures).

Complete rainfall data				Complete temperature data			
County	Years	Station	Support	County	Years	Station	Support
GALATI	1962	Galati	.xls file	GALATI	1962	Galati	.xls file
	1964	Galati	.xls file		1964	Galati	.xls file
	1965	Galati	.xls file		1965	Galati	.xls file
	1966	Galati	.xls file		1966	Galati	.xls file
BRAILA	1961	Braila (11 months)	.wk1 file	BRAILA	1961 to 1967	Viziru (monthly average)	.xls file
		Viziru	.wk1 file		1964 to 1967	Viziru (average / decade)	.xls file
	1962	Viziru	paper		1987	Braila	.xls file
	1964	Braila	paper		(1990)	Braila (lack:20 d)	.xls file
		Viziru	paper		1991	Braila	.xls file
	1965	Braila	paper		1993	Braila	.xls file
		Viziru	paper		(1994)	Braila (lack:10 d)	.xls file
	1966	Braila	paper				
		Viziru	paper				
	1967	Braila	paper				
		Viziru	paper				
	1987	Braila	.xls file				
	(1990)	Braila (lack:20 d)	.xls file				
	1991	Braila	.xls file				
1993	Braila	.xls file					
(1994)	Braila (lack:10 d)	.xls file					
TULCEA	1961	Jurilofca (S-E)	.wk1 file	TULCEA	1961 to 1967	Jurilovca (monthly average)	.xls file
	1962	Jurilofca (S-E)	paper				
	1964	Jurilofca (S-E)	paper				
	1965	Jurilofca (S-E)	paper				
	1966	Jurilofca (S-E)	paper				
	1967	Jurilofca (S-E)	paper				
CONSTANTA	1961	Hirsova	.wk1 file	CONSTANTA	1961 to 1967	Harsova (monthly average)	.xls file
	1962	Hirsova	paper		1964 to 1967	Medgidia (average / decade)	.xls file
		Valu Lui Traian	paper		1964 to 1967	Adamclisi (average / decade)	.xls file
		Adamclisi	paper		1987	Valu Lui Traian	.xls file
	1964	Hirsova	paper		1989	Valu Lui Traian	.xls file
		Valu Lui Traian	paper		1990	Valu Lui Traian	.xls file
	1965	Hirsova	paper		1991	Valu Lui Traian	.xls file
		Valu Lui Traian	paper		1993	Valu Lui Traian	.xls file
	1966	Hirsova	paper		1994	Valu Lui Traian	.xls file
		Valu Lui Traian	paper				
	1967	Hirsova	paper				
		Valu Lui Traian	paper				
	1987	Valu Lui Traian	.xls file				
	1989	Valu Lui Traian	.xls file				
	1990	Valu Lui Traian	.xls file				
	1991	Valu Lui Traian	.xls file				
	1993	Valu Lui Traian	.xls file				
	1994	Valu Lui Traian	.xls file				
	1995	Valu Lui Traian	.xls file				
IALOMITA	1961	Urziceni	.wk1 file	IALOMITA	1961 to 1967	Urziceni (monthly average)	.xls file
	1962	Grivita	.xls file		1964 to 1967	Marculesti (average / decade)	.xls file
		Urziceni	paper		1962	Grivita	.xls file
	1964	Grivita	.xls file		1964	Grivita	.xls file
		Marculesti	paper		1965	Grivita	.xls file
		Urziceni	paper		1966	Grivita	.xls file
	1965	Grivita	.xls file		1967	Grivita	.xls file
		Marculesti	paper		1989	Marculesti	.xls file
		Urziceni	paper		1990	Marculesti	.xls file
	1966	Grivita	.xls file		(1991)	Marculesti (lack:30 d)	.xls file
		Marculesti	paper		1993	Marculesti	.xls file
		Urziceni	paper		(1994)	Marculesti (lack:40 d)	.xls file
	1967	Grivita	.xls file				
		Marculesti	paper				
	1989	Marculesti	.xls file				
	1990	Marculesti	.xls file				
	(1991)	Marculesti (lack:30 d)	.xls file				
	1993	Marculesti	.xls file				

APPENDIX D

Occurrence of Rainfall events : frequential analysis for each county

Occurrence of Rainfall events : frequential analysis for each county

Following graphs were established on the basis of monthly sums of rainfall in different counties. Some of the data were on “paper” format and had to be encoded. Climate of each county is represented only by one station and series of data come from years 1961 to 1997 in such way that non-interrupted series are rare.

GALATI county

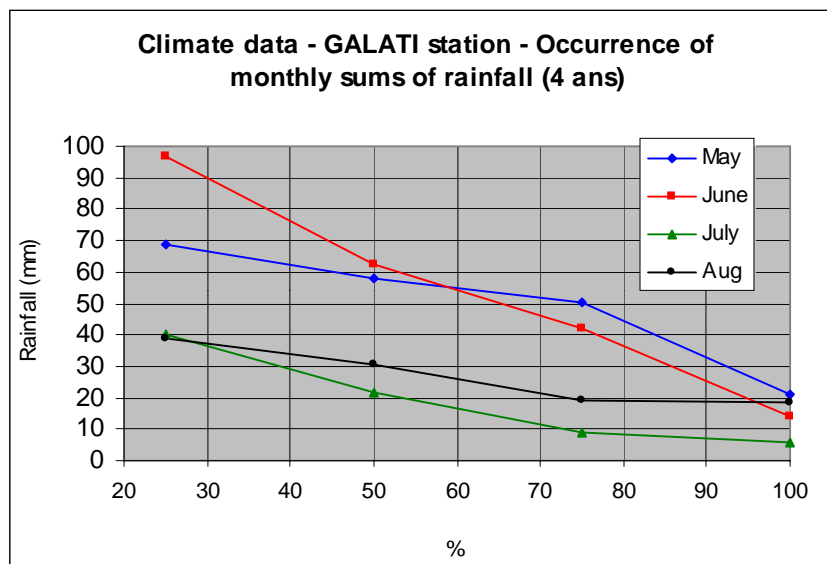
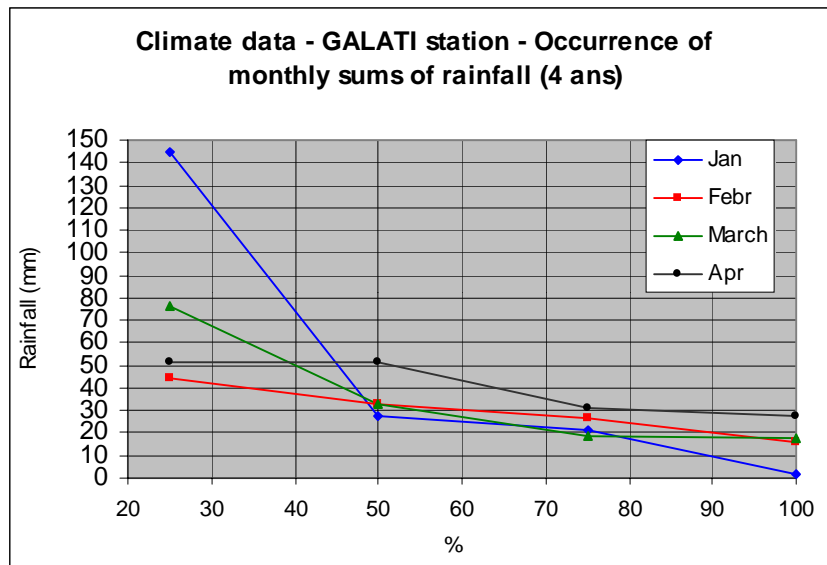

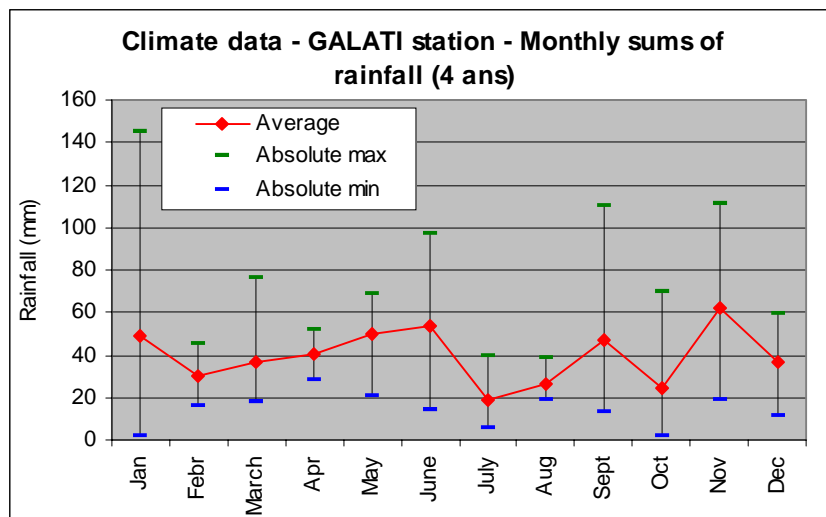
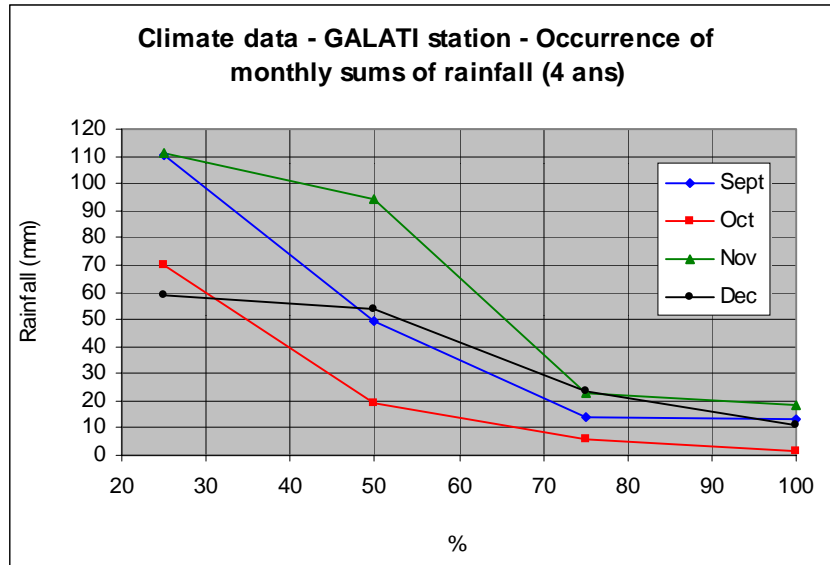

BRAILA county

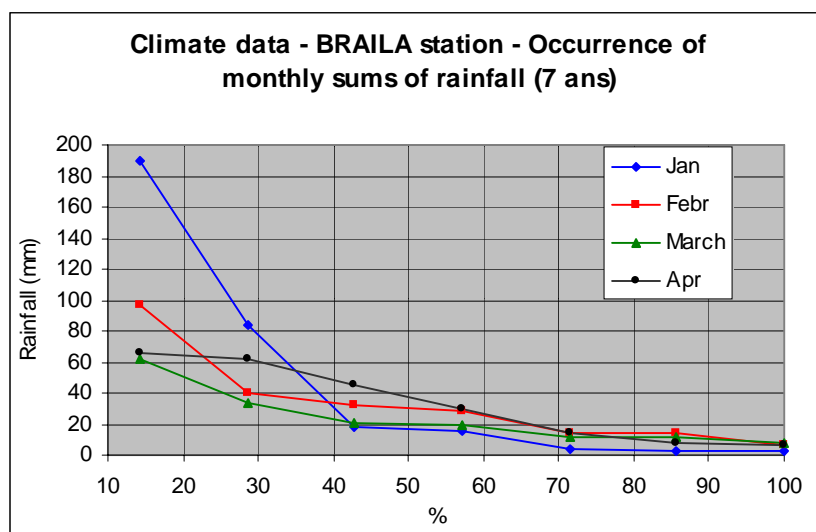

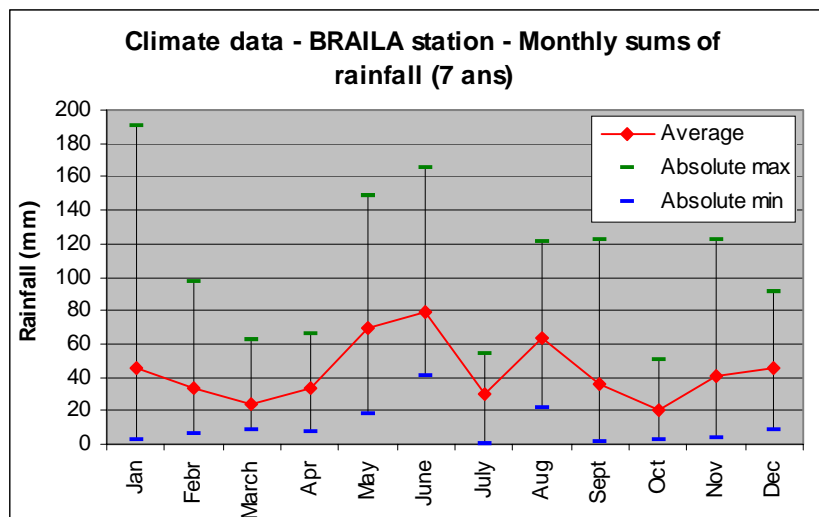
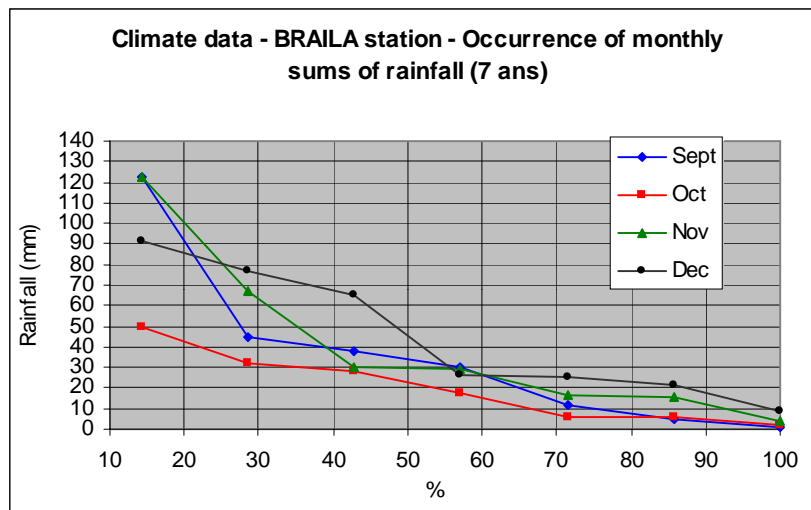
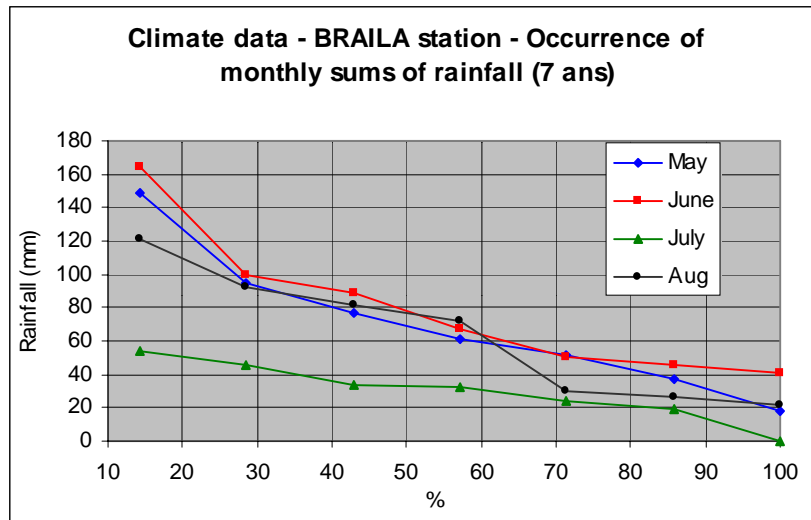

TULCEA county

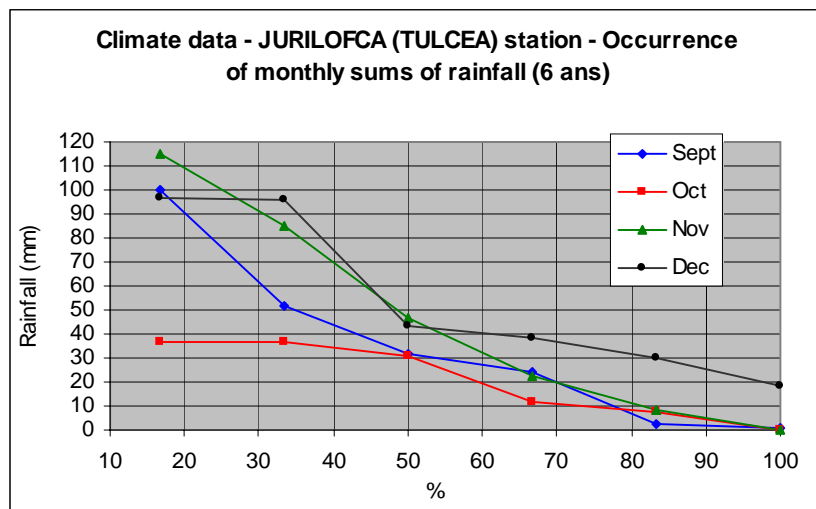
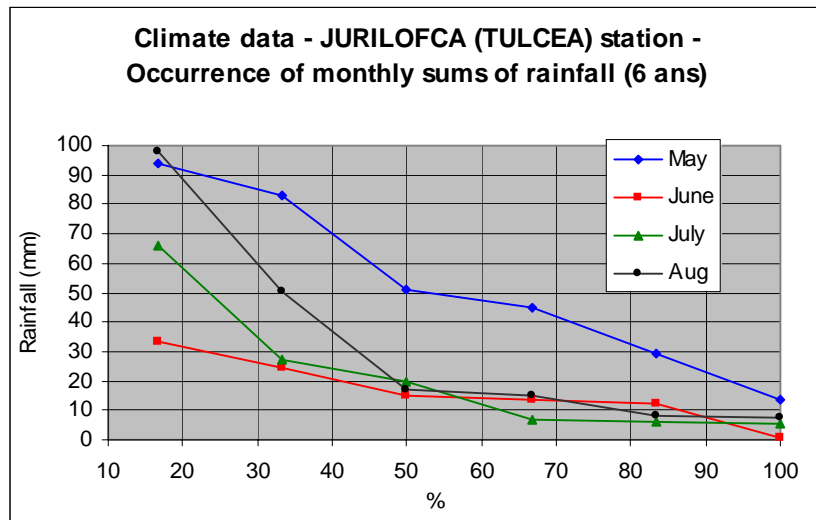
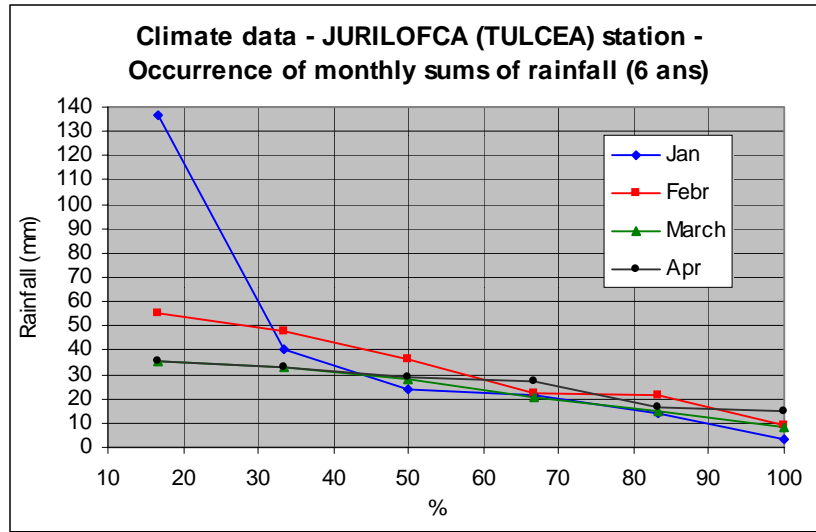

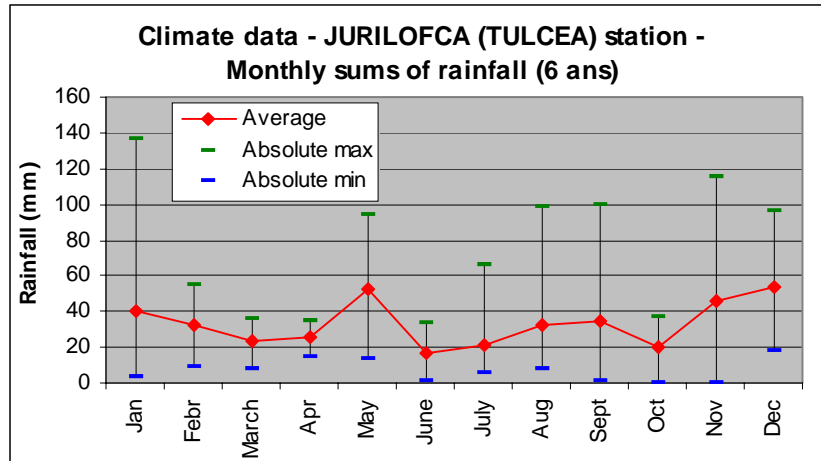

CONSTANTA county

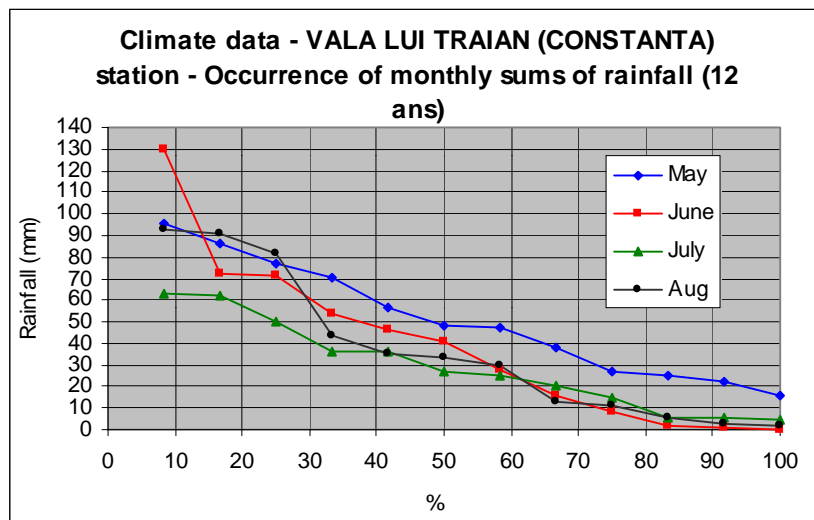
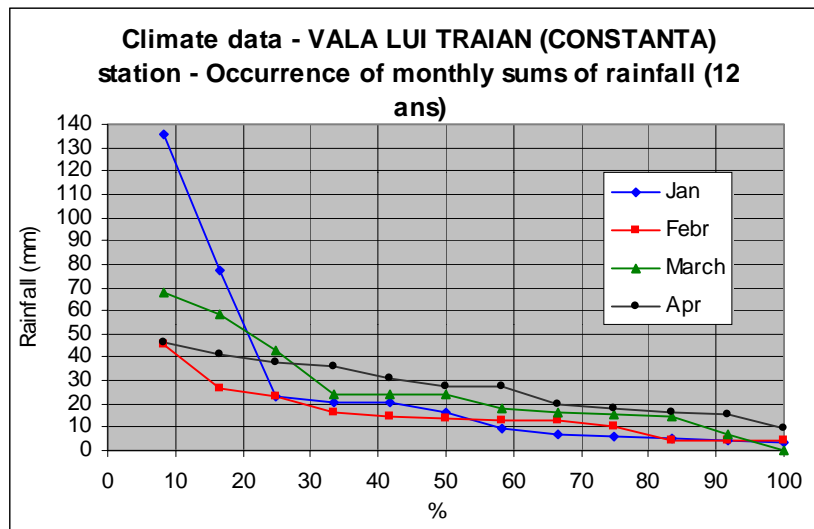

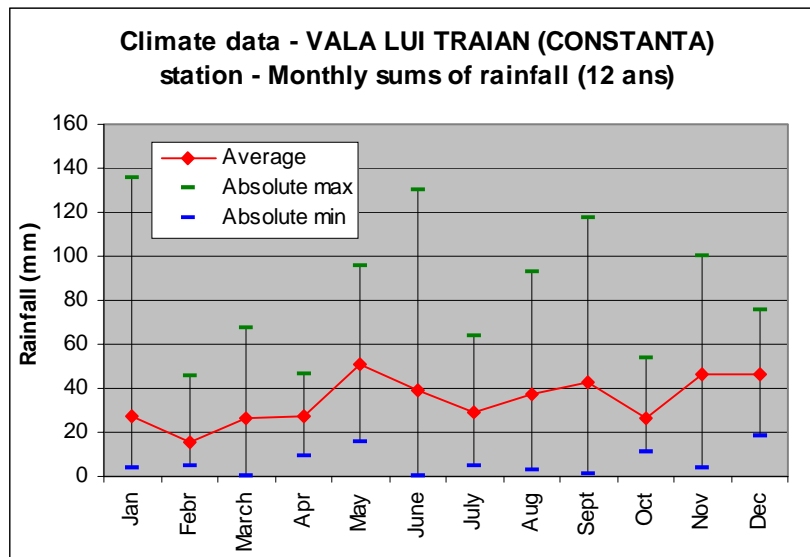
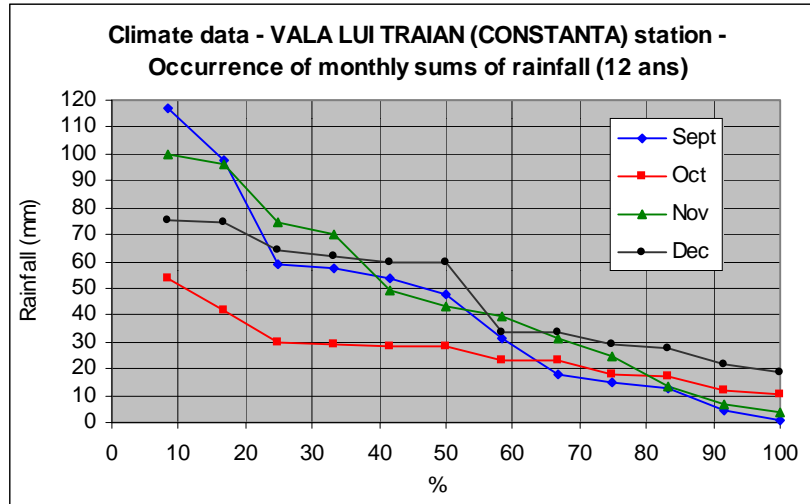

IALOMITA county

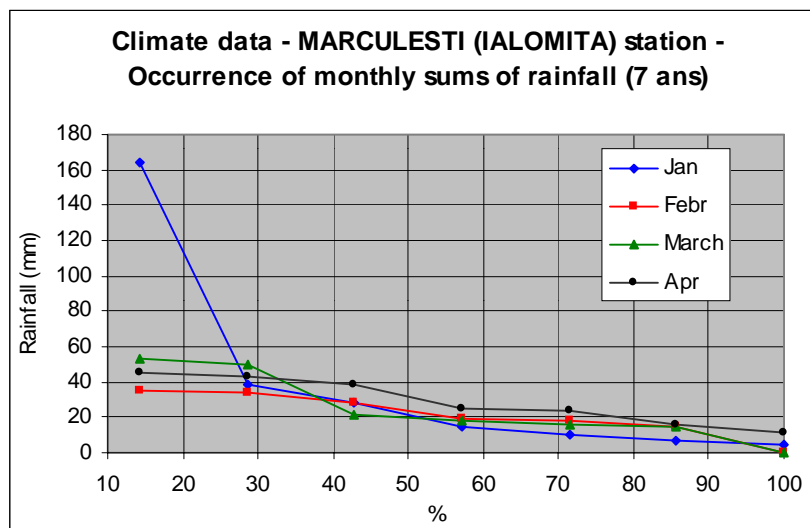

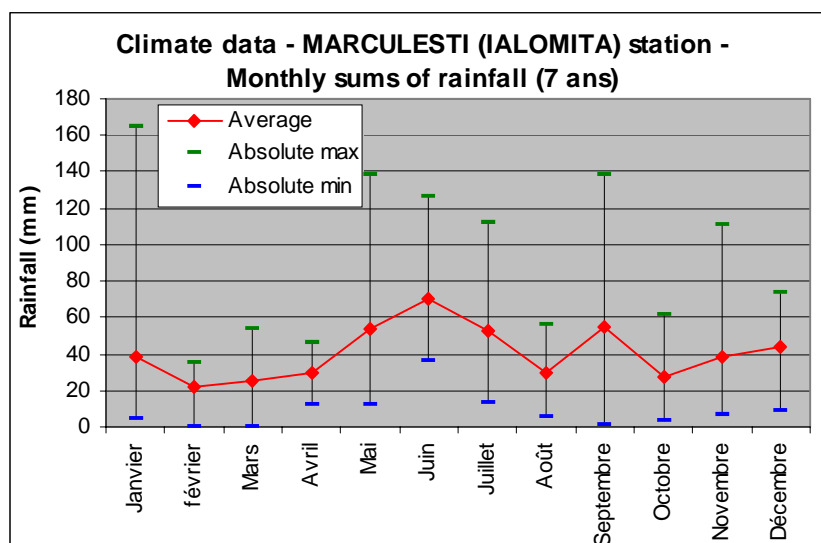
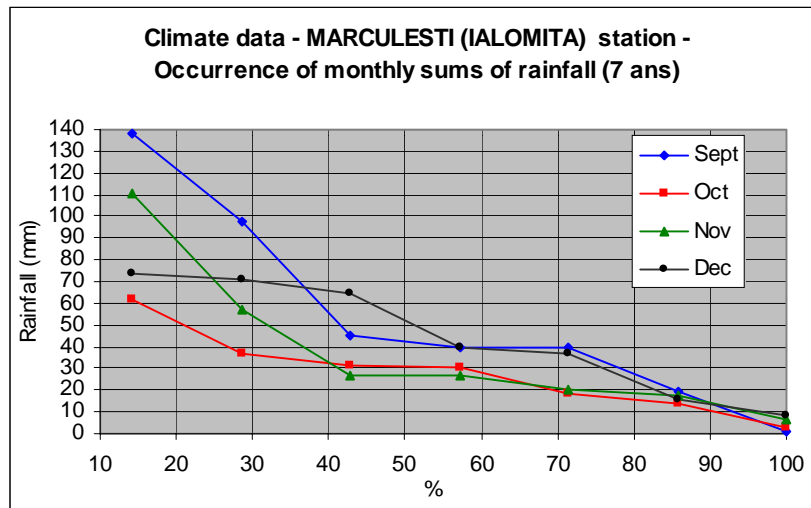
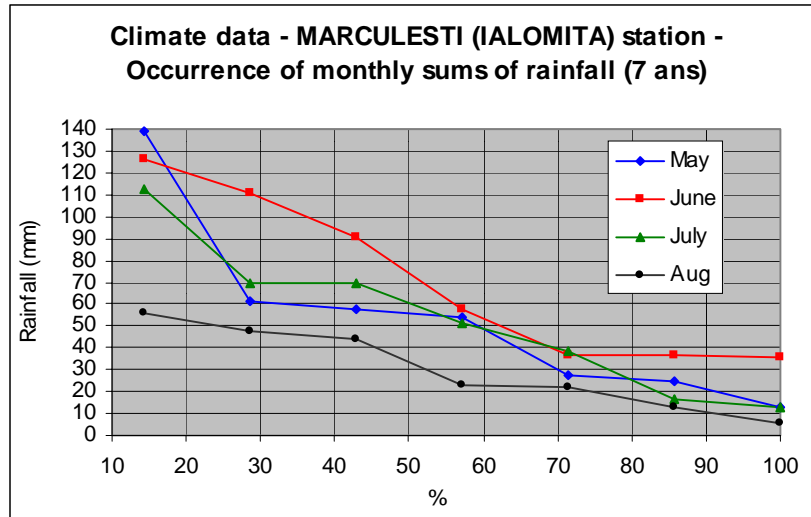

CALARASI county

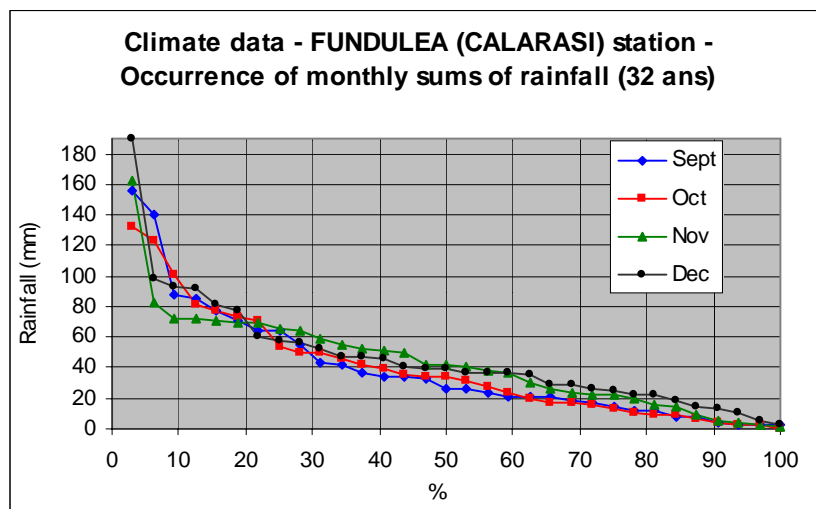
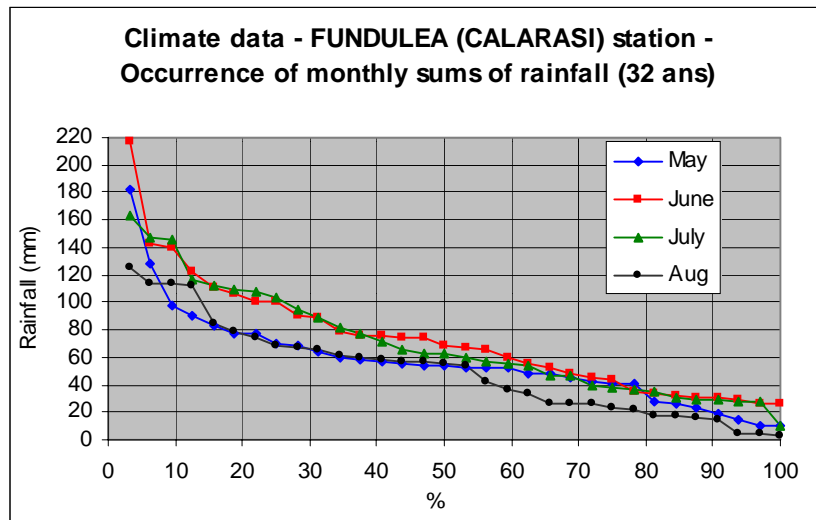
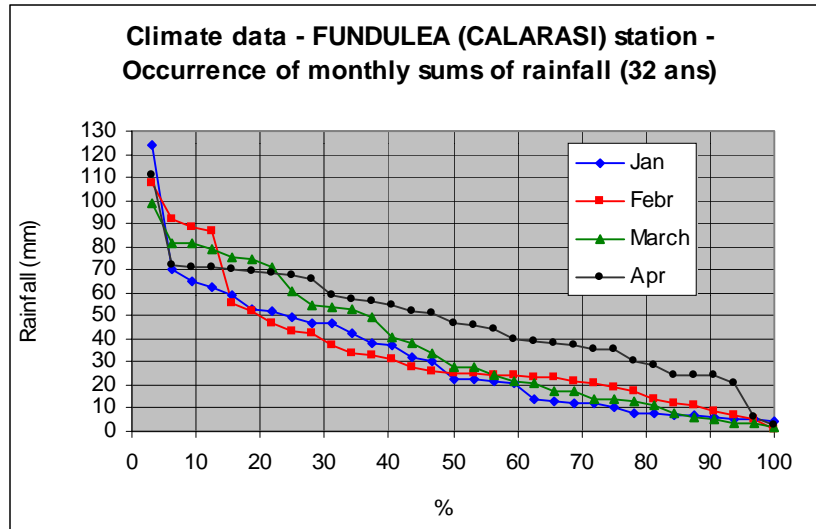

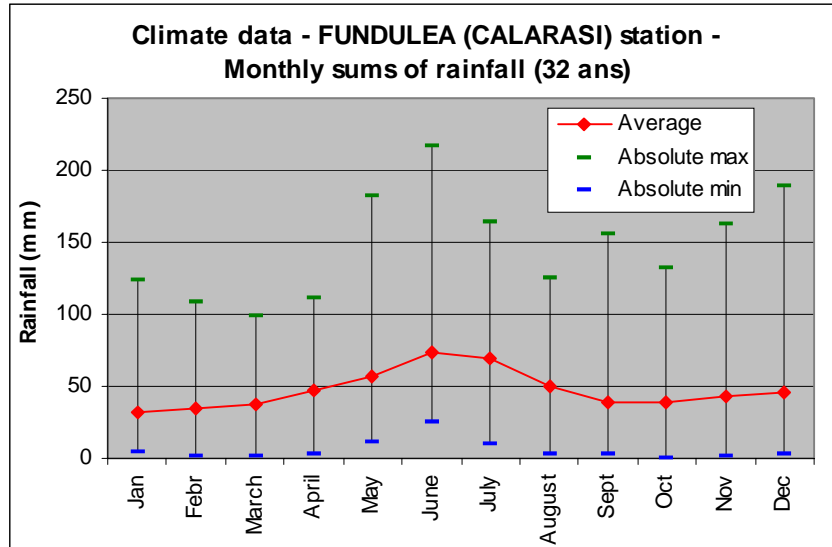

ILFOV county

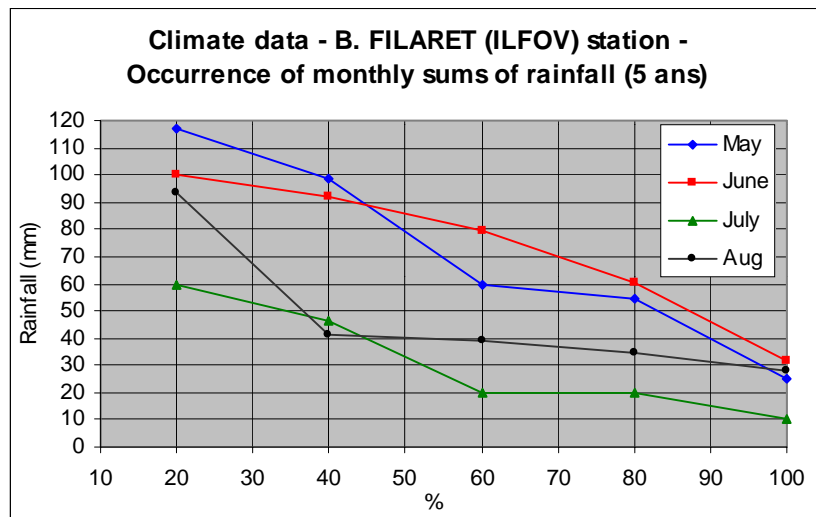
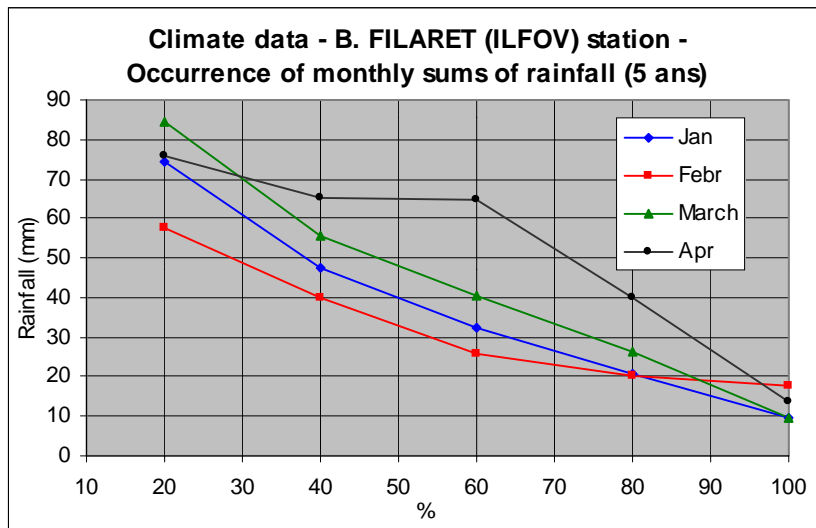

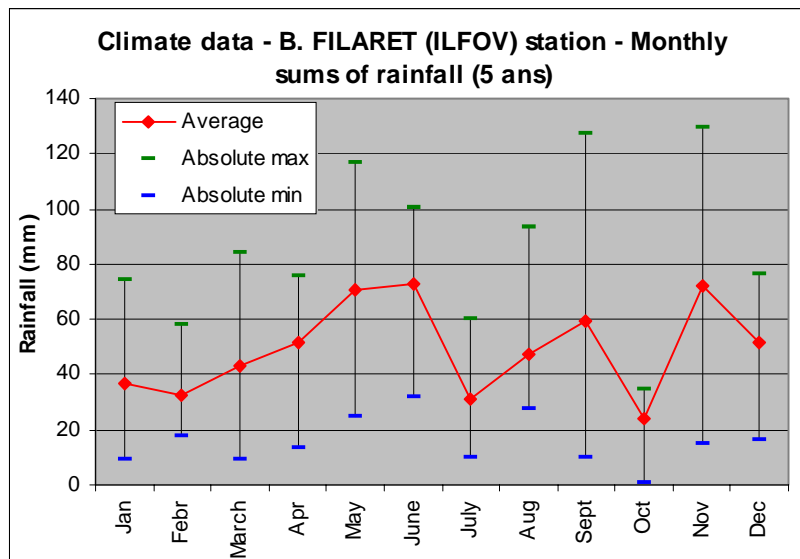
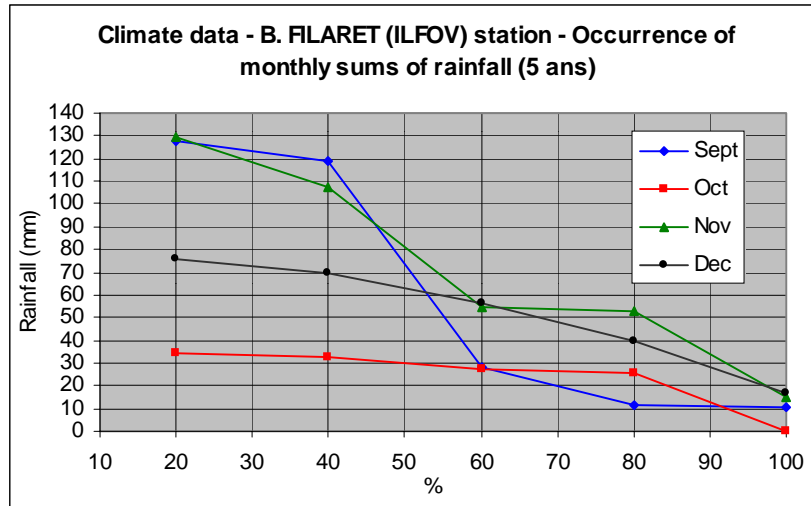

GIURGIU county

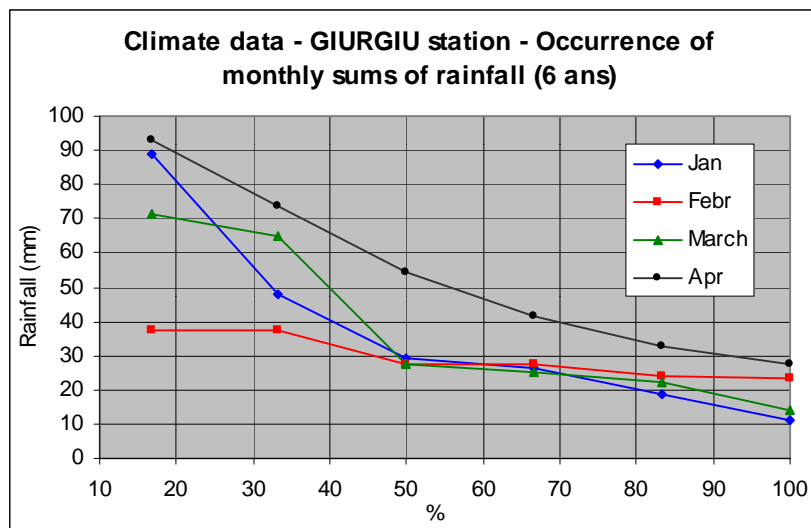

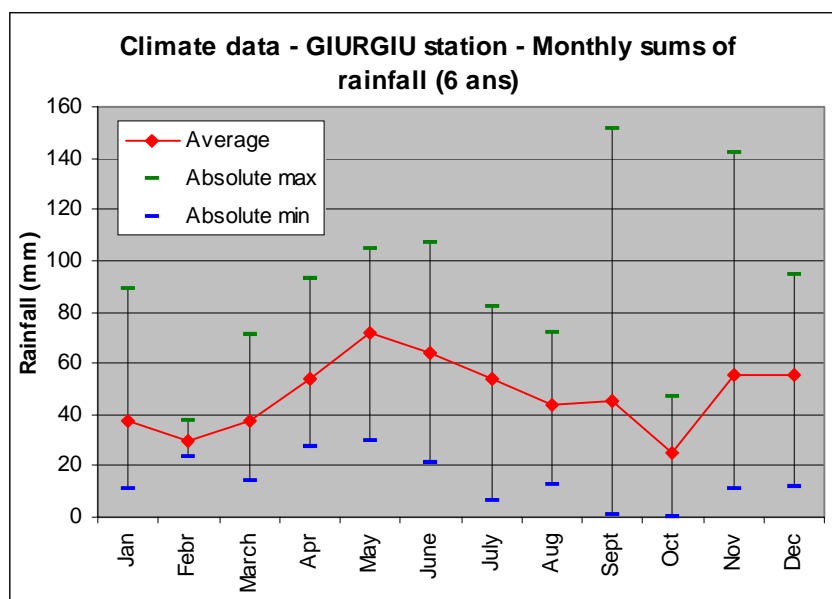
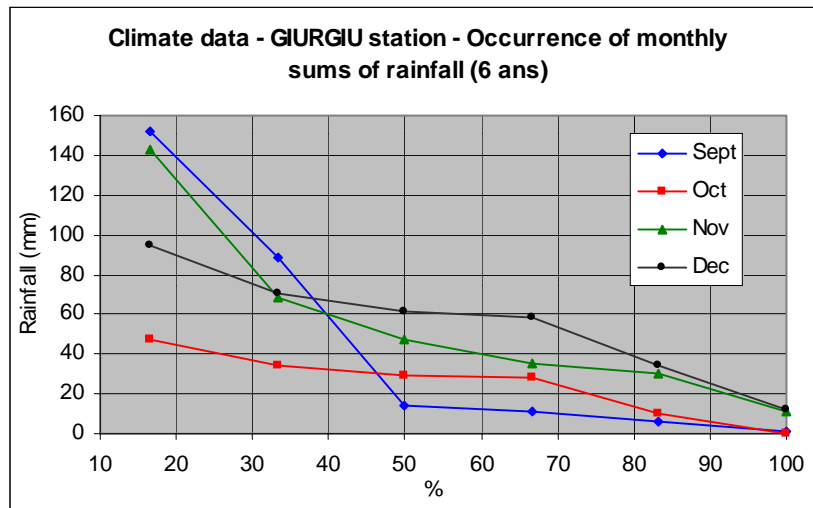
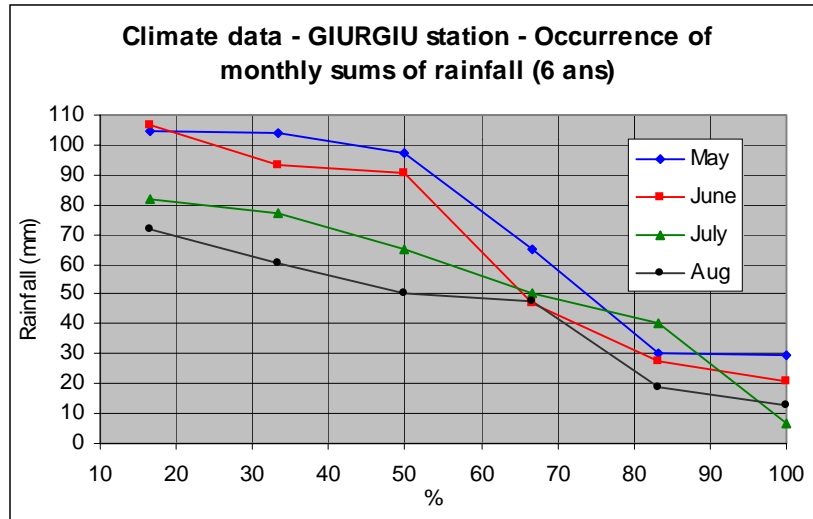

TELEORMAN county

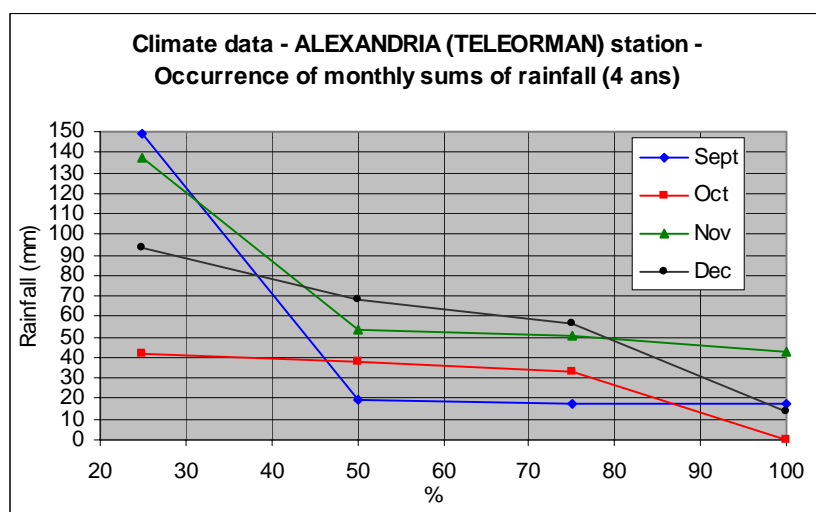
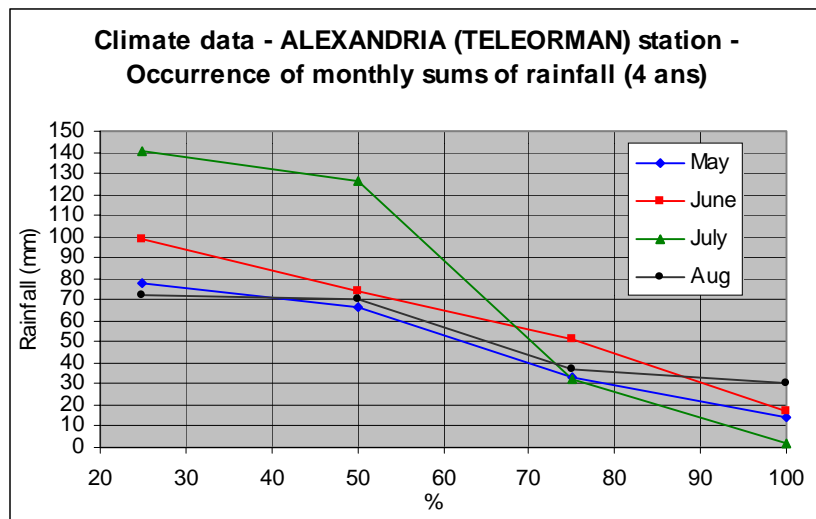
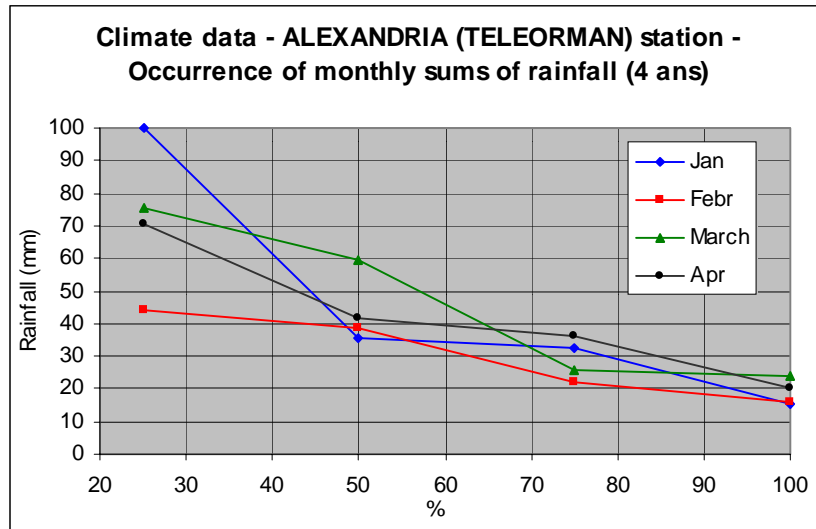

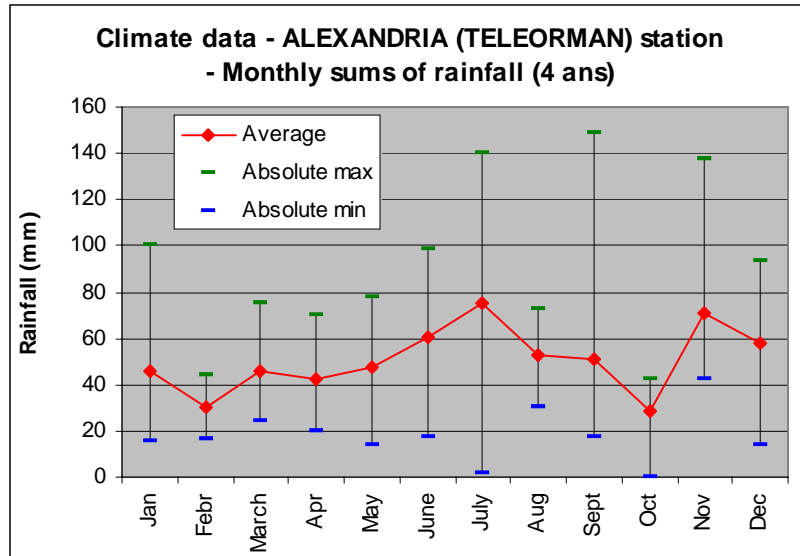

OLT county

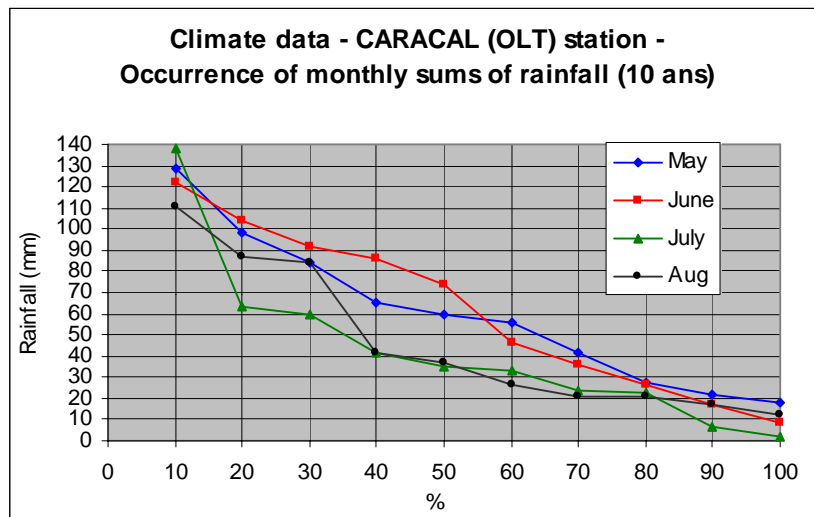
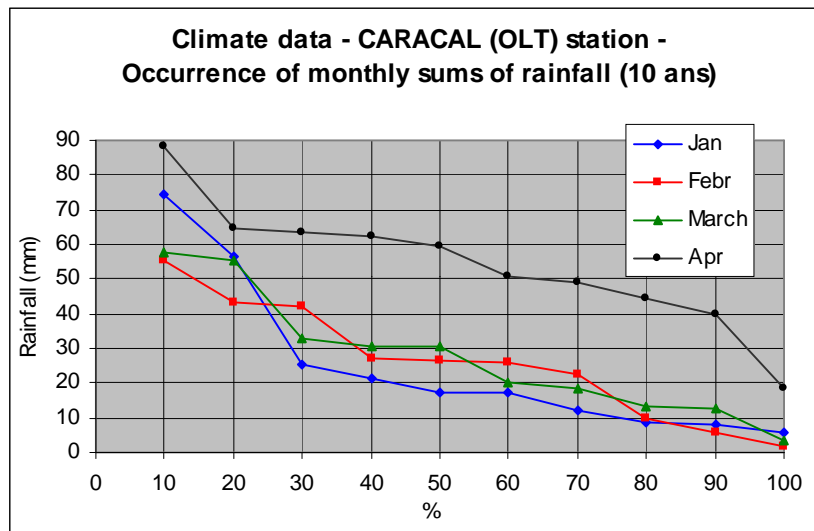

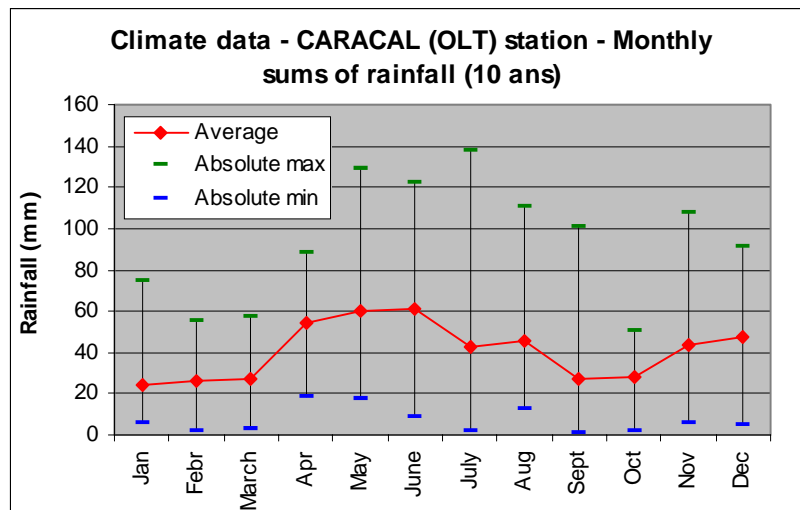
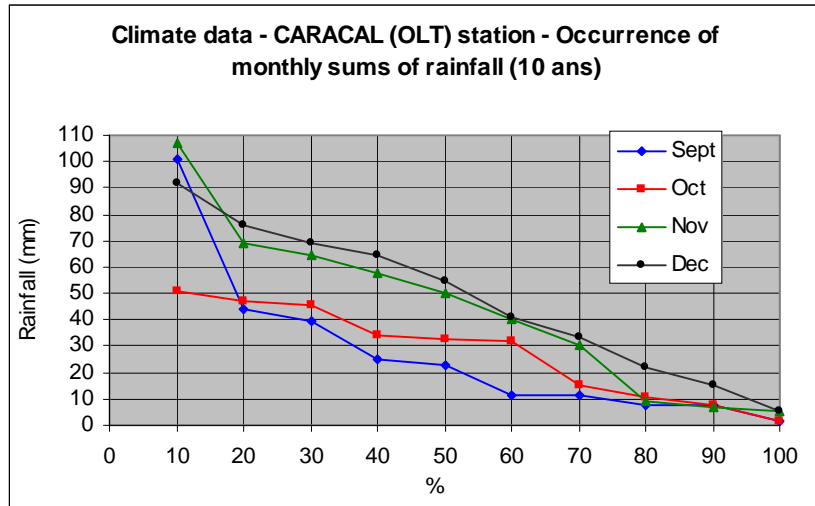

DOLJ county

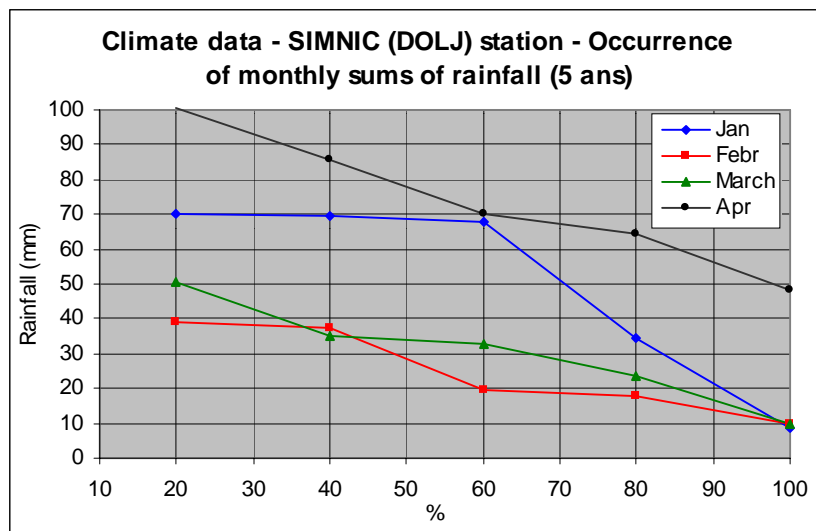

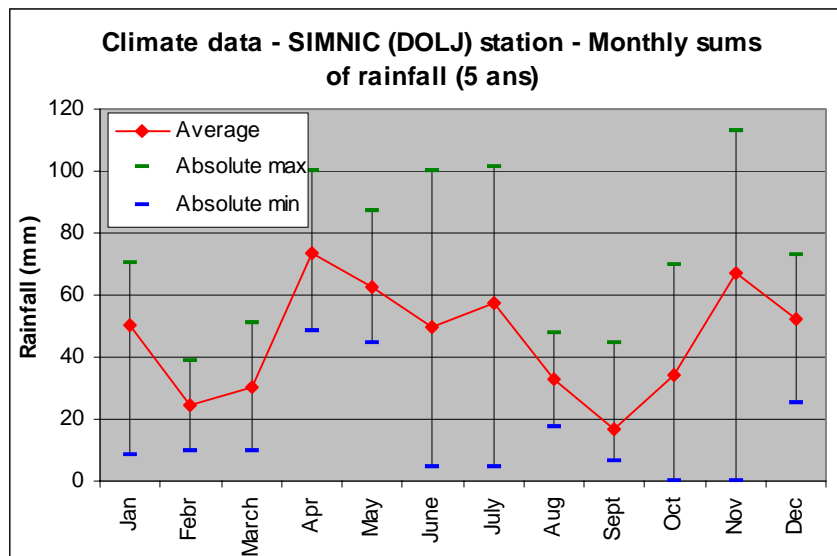
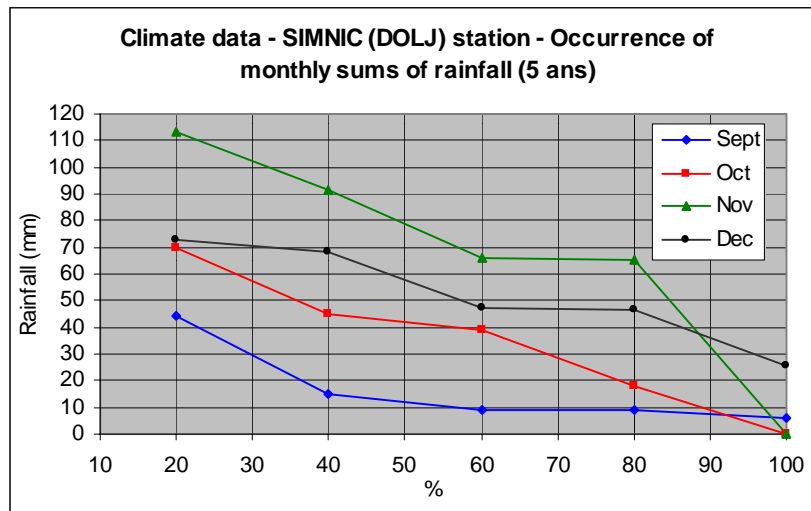
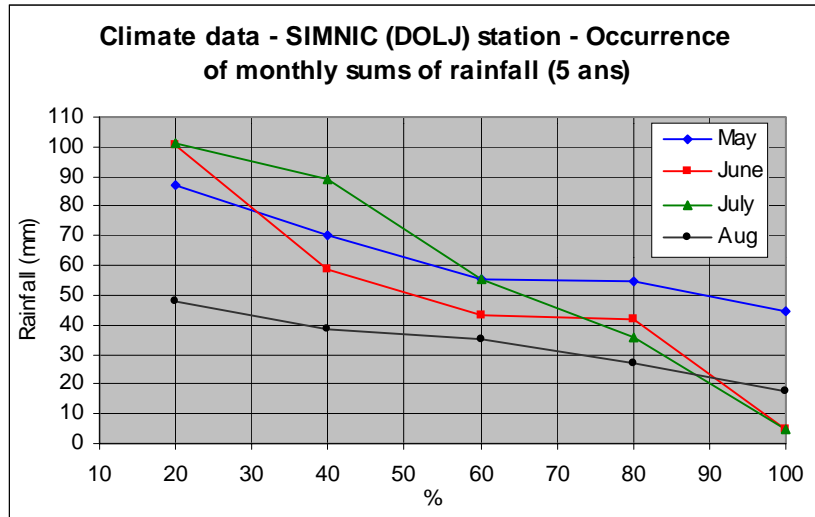

APPENDIX E

Major crops and animals by county

Major crops and animals by county

GALATI county

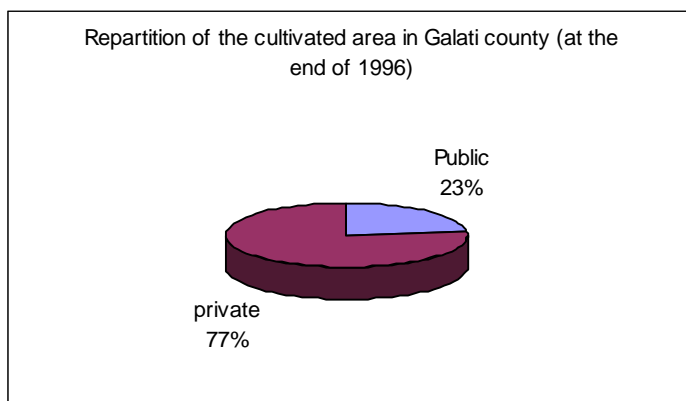

	Galati		
	Total	Public	Private
Total Cattle	60000	5000	55000
Cows & heifers	31000	2000	29000
Total Pigs	153000	76000	77000
Sow for breeding	11000	6000	5000
Total Sheeps	226000	43000	183000
Ewes	160000	26000	134000
Goats	16000	0	16000
Horses	23000	1000	22000
Total Poultry	4082000	2334000	1748000
Laying poultry	1111000	360000	751000
Cultivated area (ha)	285761	67048	218713

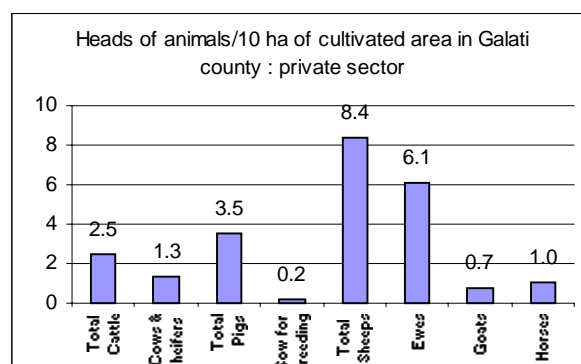
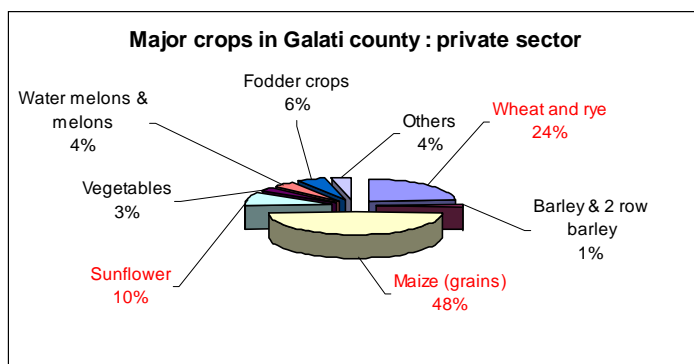
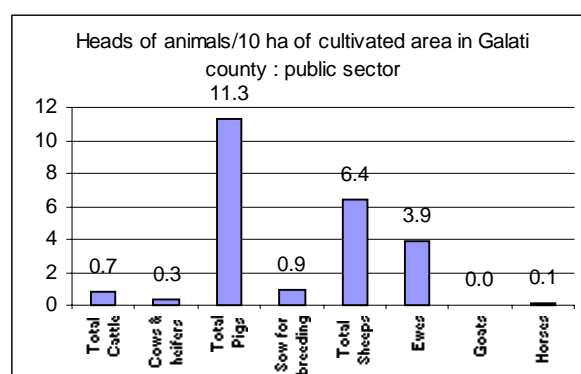
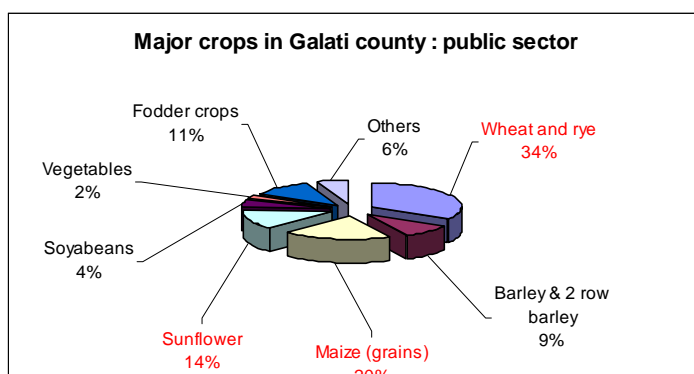
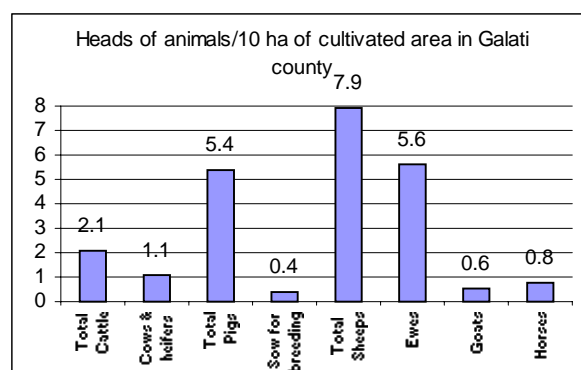
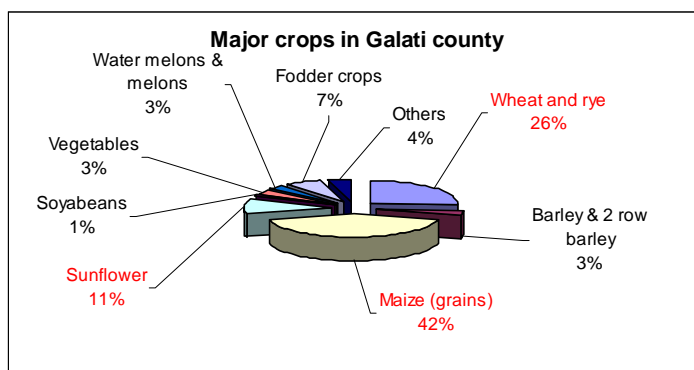

BRILA county

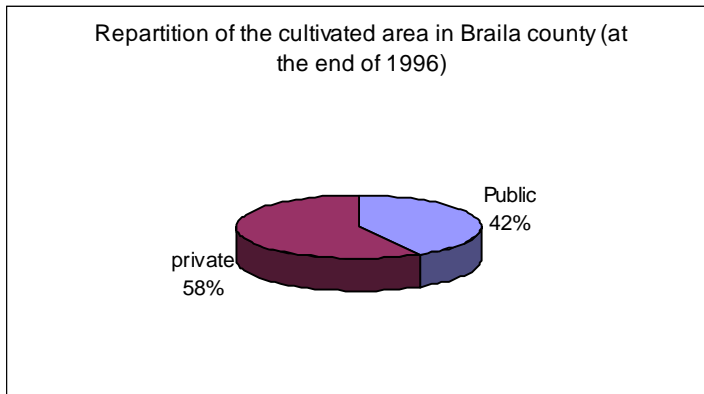

	Braila		
	Total	Public	Private
Total Cattle	62000	11000	51000
Cows & heifers	32000	5000	27000
Total Pigs	323000	144000	179000
Sow for breeding	25000	13000	12000
Total Sheeps	285000	55000	230000
Ewes	208000	33000	175000
Goats	6000	0	6000
Horses	27000	1000	26000
Total Poultry	1444000	230000	1214000
Laying poultry	1045000	208000	837000
Cultivated area (ha)	326076	136260	189816

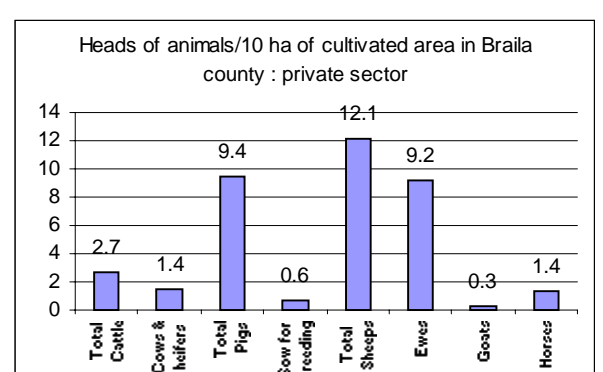
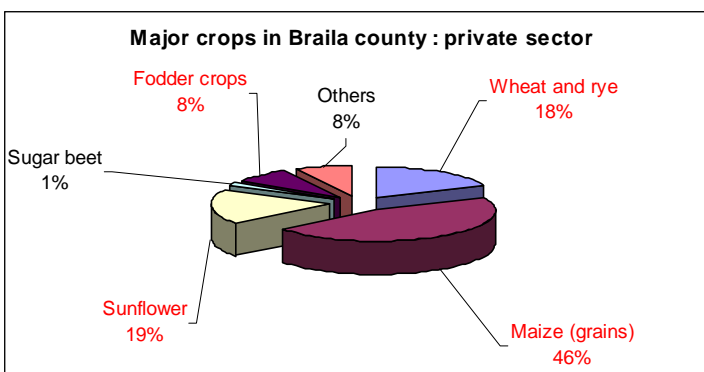
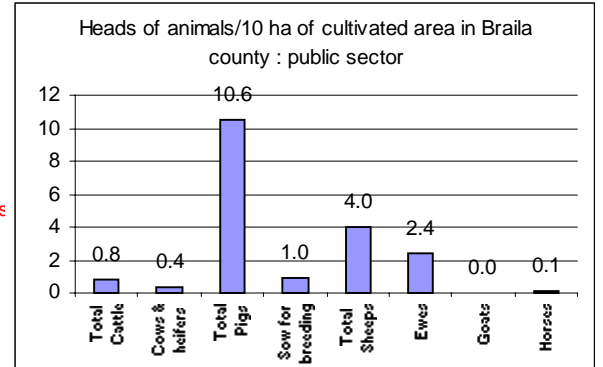
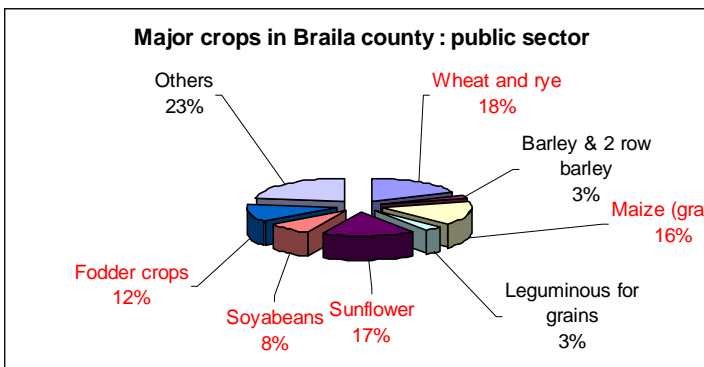
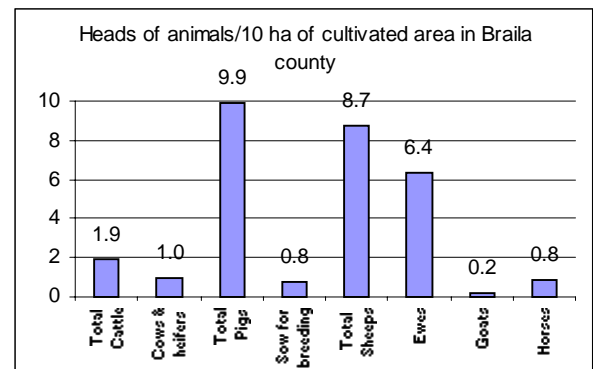
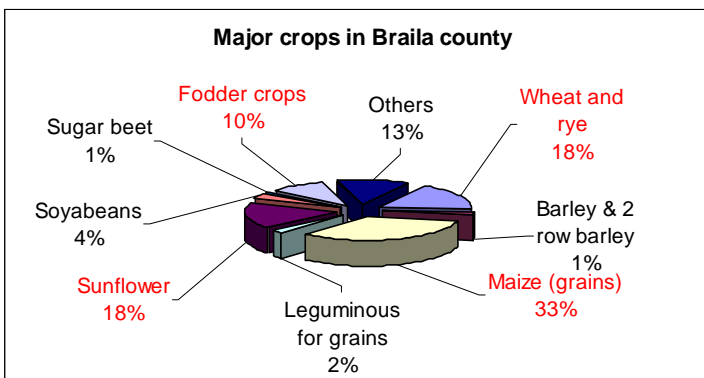

TULCEA county

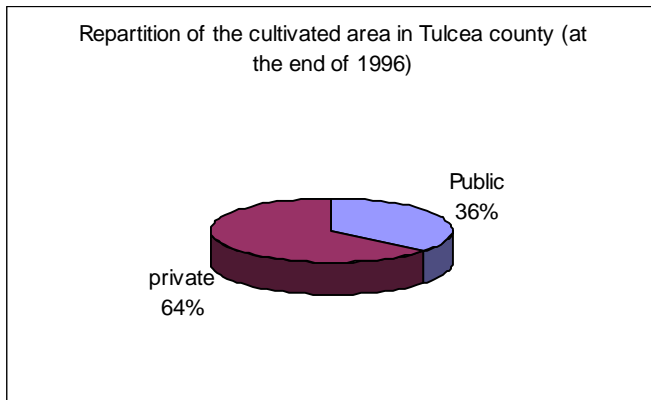

	Tulcea		
	Total	Public	Private
Total Cattle	38000	4000	34000
Cows & heifers	17000	1000	16000
Total Pigs	115000	24000	91000
Sow for breeding	11000	3000	8000
Total Sheep	282000	31000	251000
Ewes	214000	22000	192000
Goats	31000	0	31000
Horses	15000	0	15000
Total Poultry	962000	156000	806000
Laying poultry	364000	1000	363000
Cultivated area (ha)	256790	93280	163510

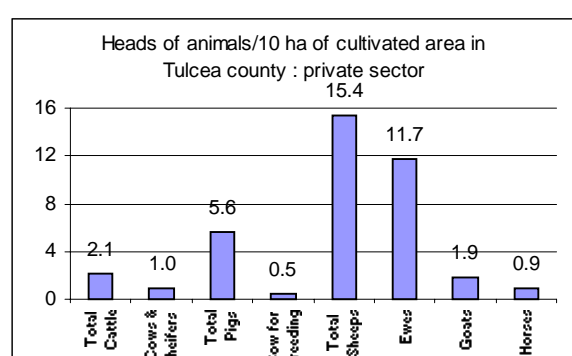
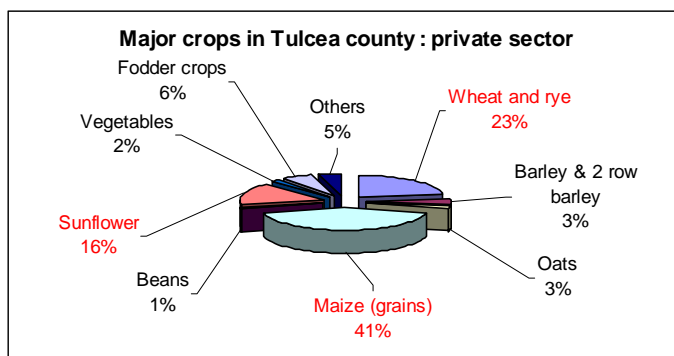
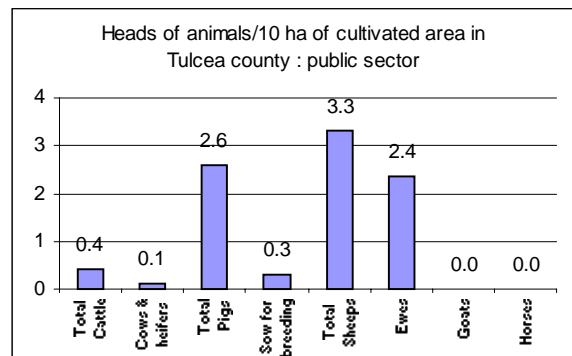
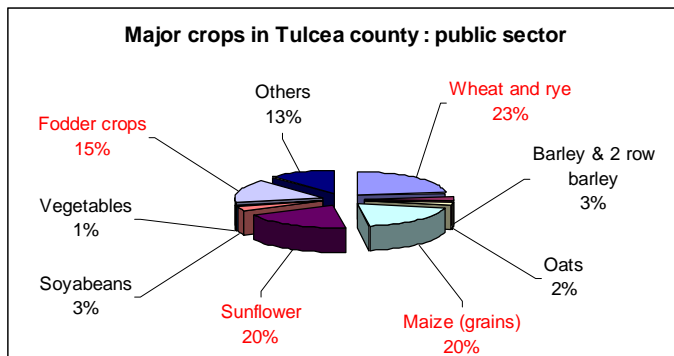
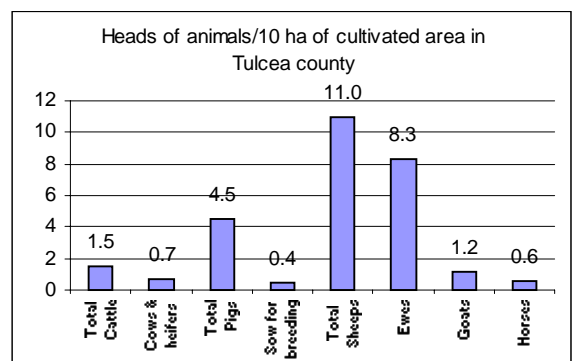
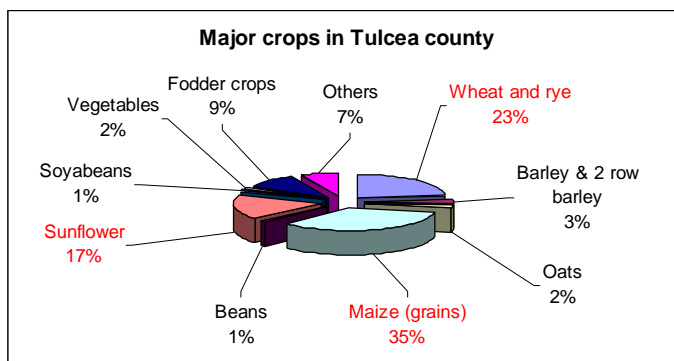

CONSTANTA county

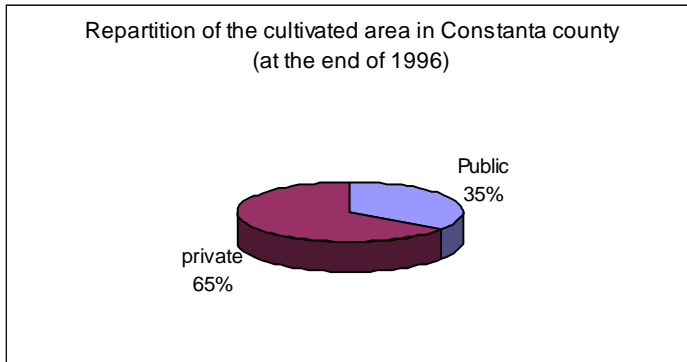

	Constanta		
	Total	Public	Private
Total Cattle	55000	22000	33000
Cows & heifers	28000	9000	19000
Total Pigs	279000	150000	129000
Sow for breeding	25000	13000	12000
Total Sheeps	386000	52000	334000
Ewes	281000	36000	245000
Goats	24000	0	24000
Horses	17000	2000	15000
Total Poultry	2776000	1530000	1246000
Laying poultry	1301000	355000	946000
Cultivated area (ha)	470740	164856	305884

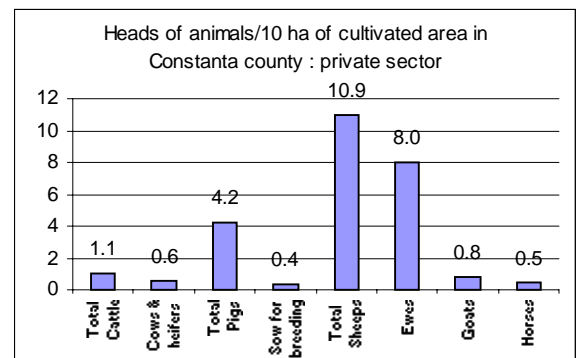
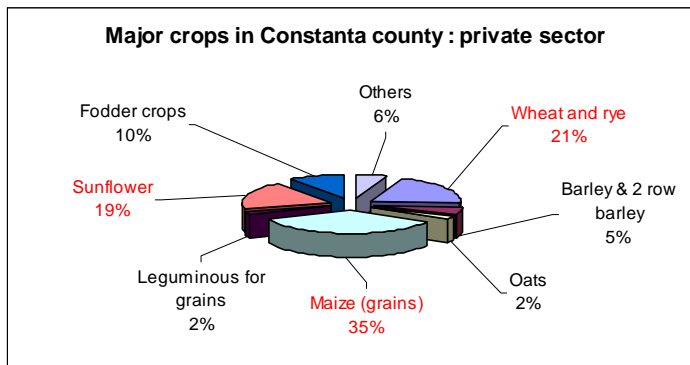
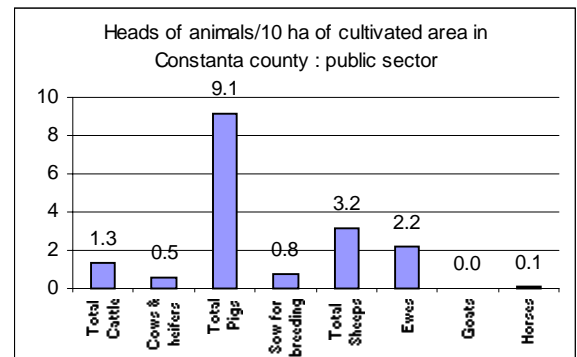
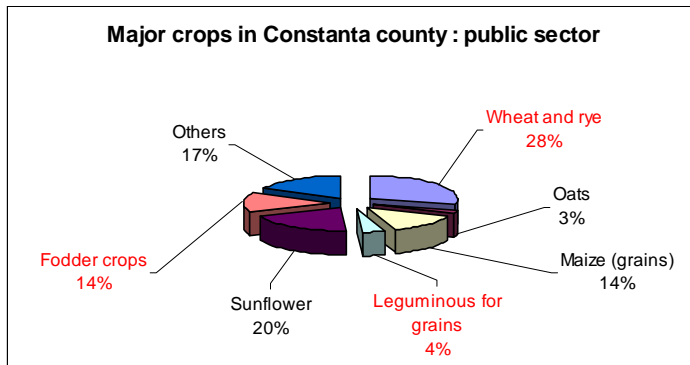
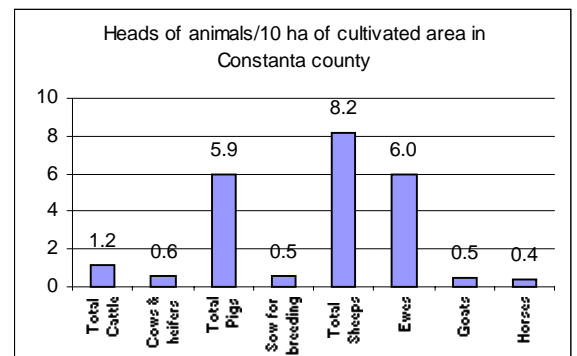
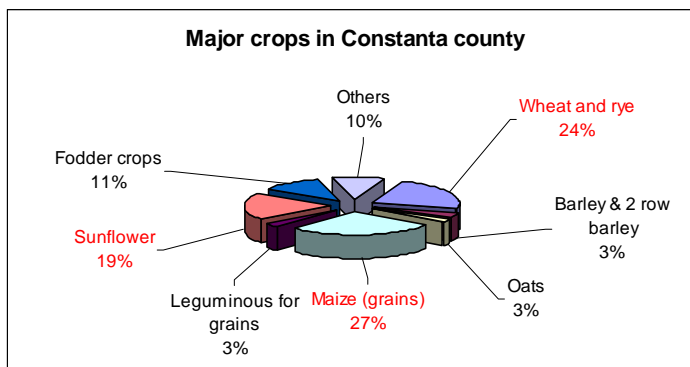

IALOMITA county

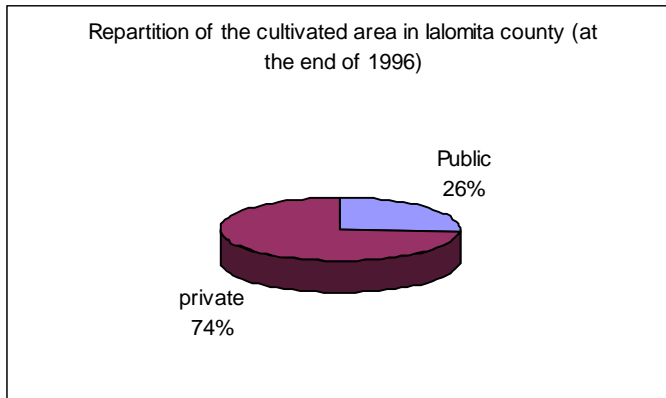

	Ialomita		
	Total	Public	Private
Total Cattle	53000	9000	44000
Cows & heifers	34000	4000	30000
Total Pigs	528000	445000	83000
Sow for breeding	38000	33000	5000
Total Sheeps	191000	30000	161000
Ewes	147000	21000	126000
Goats	8000	0	8000
Horses	21000	1000	20000
Total Poultry	1355000	434000	921000
Laying poultry	743000	127000	616000
Cultivated area (ha)	344539	90702	253837

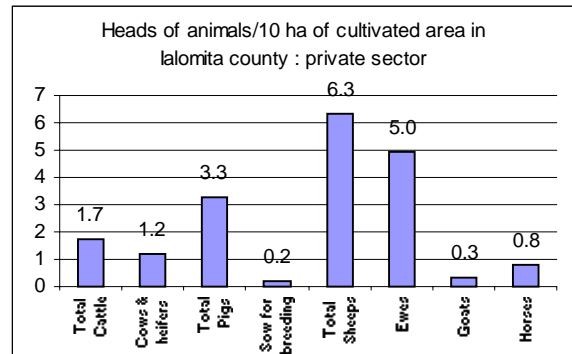
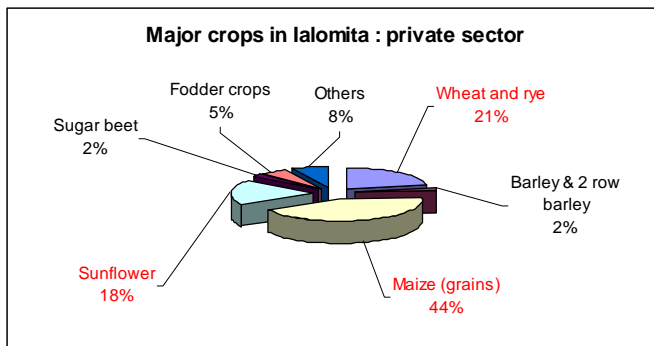
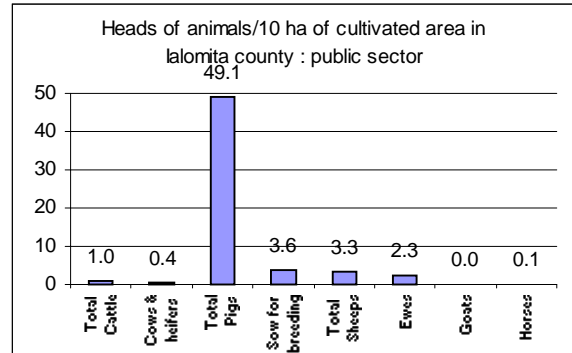
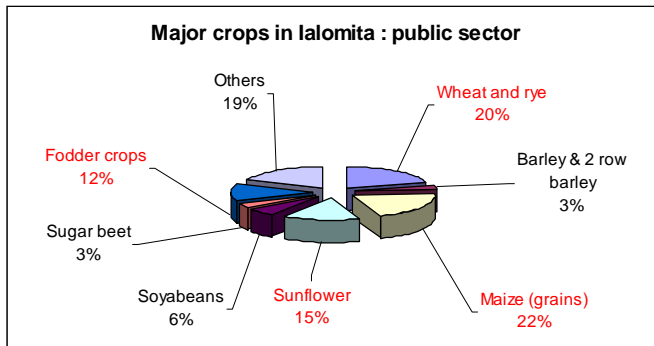
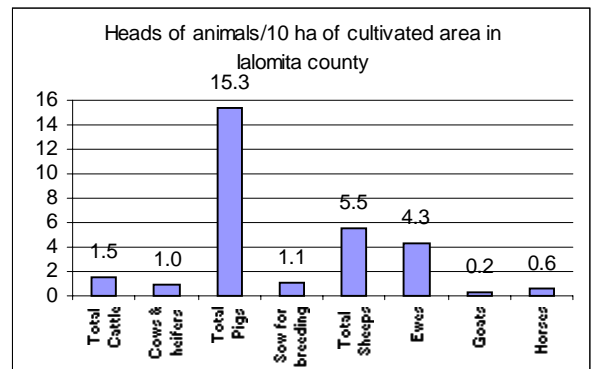
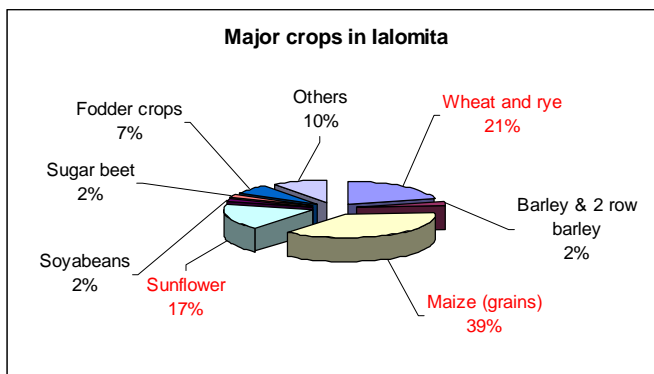

CALARASI county

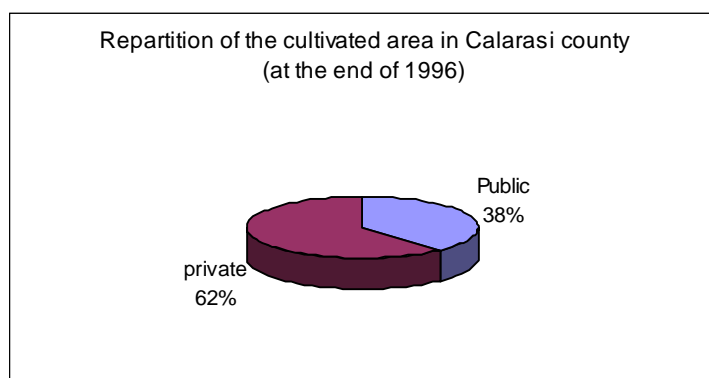

	Calarasi		
	Total	Public	Private
Total Cattle	47000	11000	36000
Cows & heifers	21000	3000	18000
Total Pigs	500000	398000	102000
Sow for breeding	35000	28000	7000
Total Sheeps	227000	209900	17100
Ewes	165000	152000	13000
Goats	12000	0	12000
Horses	20000	2000	18000
Total Poultry	2069000	497000	1572000
Laying poultry	866000	88000	778000
Cultivated area (ha)	404147	154976	249171

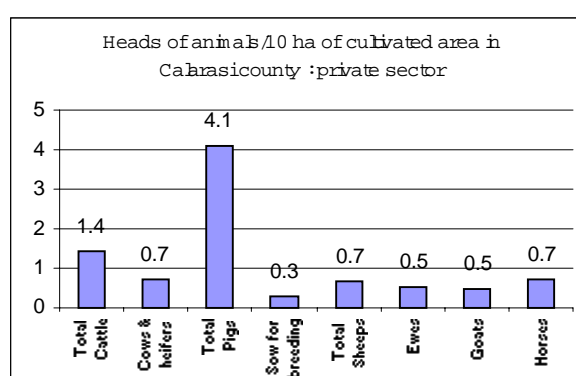
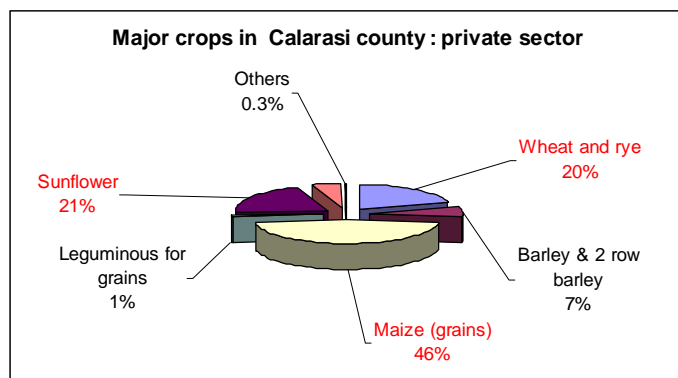
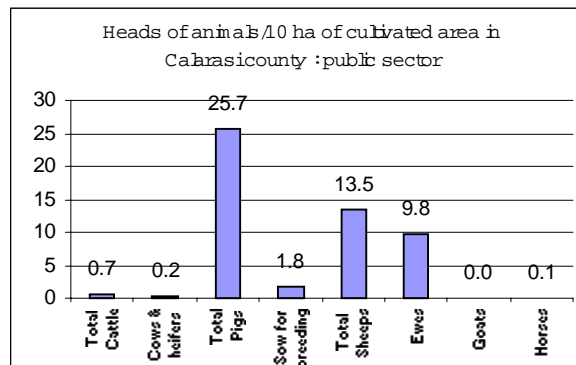
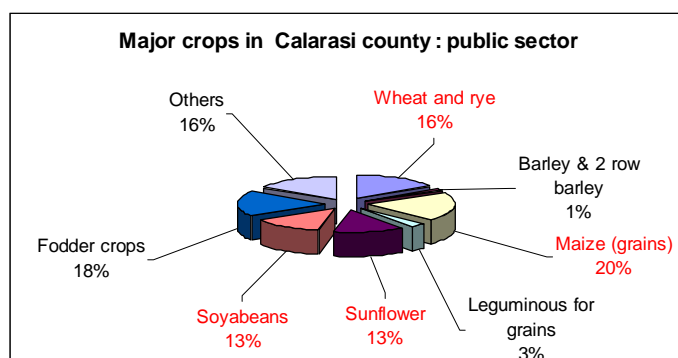
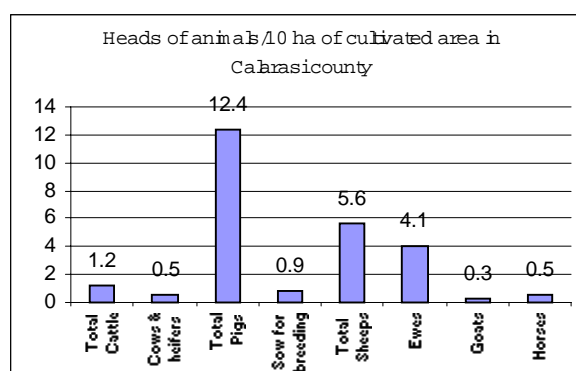
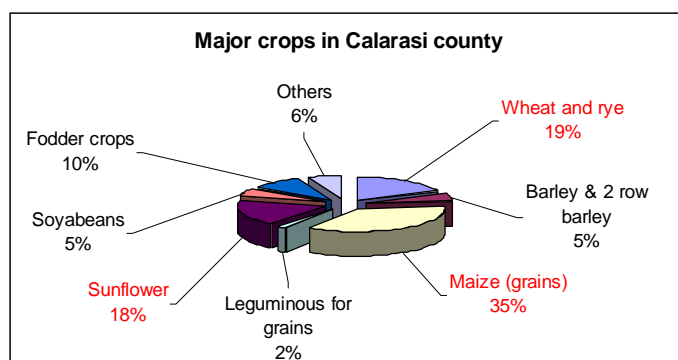

ILFOV county

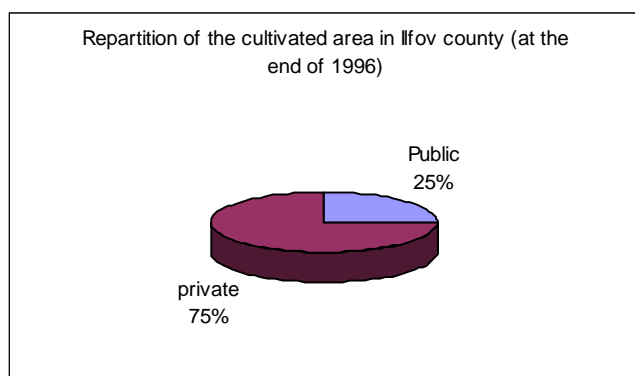

	Ilfov		
	Total	Public	Private
Total Cattle	34000	12000	22000
Cows & heifers	20000	5000	15000
Total Pigs	231000	130000	101000
Sow for breeding	22000	13000	9000
Total Sheeps	38000	4000	34000
Ewes	30000	2000	28000
Goats	5000	0	5000
Horses	6000	0	6000
Total Poultry	2782000	1995000	787000
Laying poultry	1451000	967000	484000
Cultivated area (ha)	102884	25871	77013

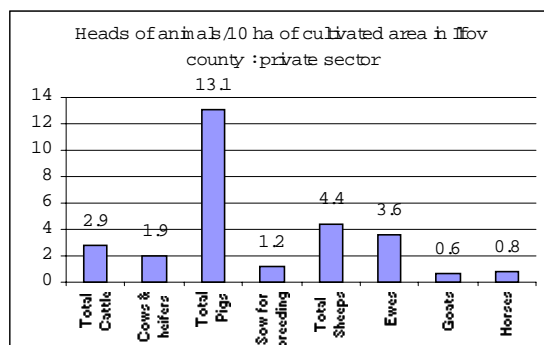
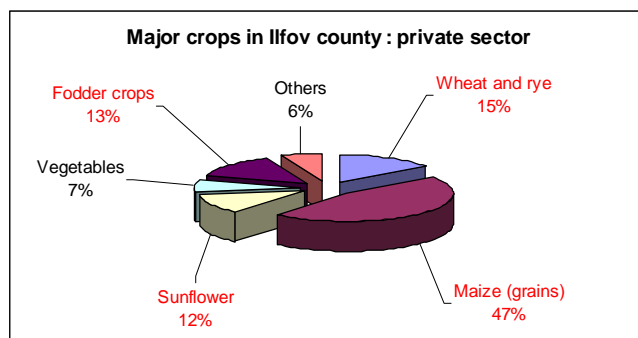
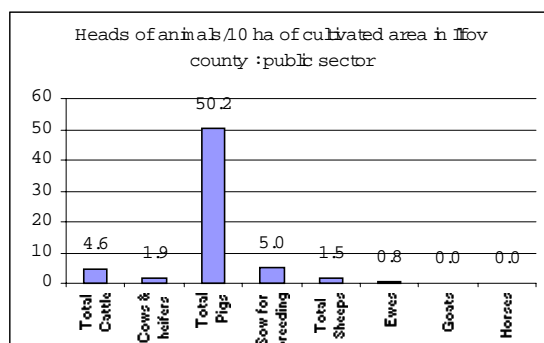
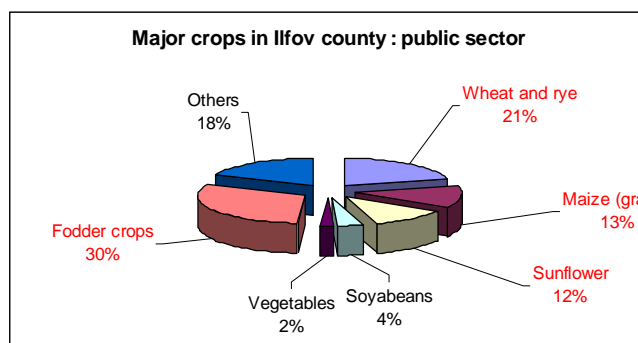
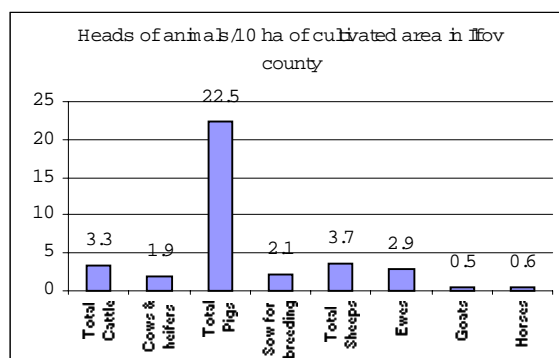
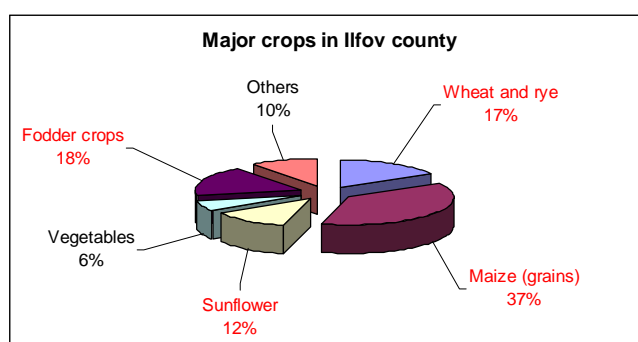

GIURGIU county

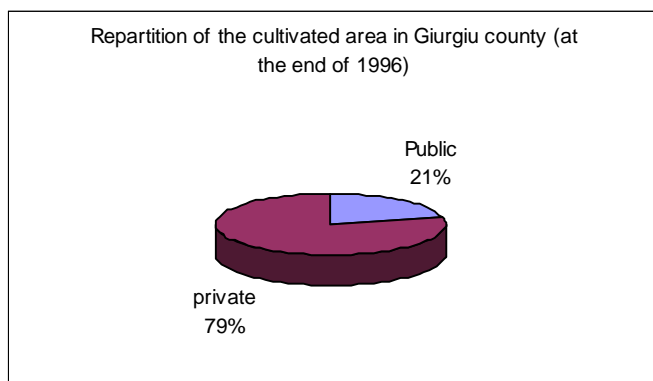

	Giurgiu		
	Total	Public	Private
Total Cattle	49000	5000	44000
Cows & heifers	32000	3000	29000
Total Pigs	176000	61000	115000
Sow for breeding	13000	4000	9000
Total Sheeps	107000	7000	100000
Ewes	75000	4000	71000
Goats	11000	0	11000
Horses	18000	1000	17000
Total Poultry	1584000	0	1584000
Laying poultry	992	0	992
Cultivated area (ha)	225282	46714	178568

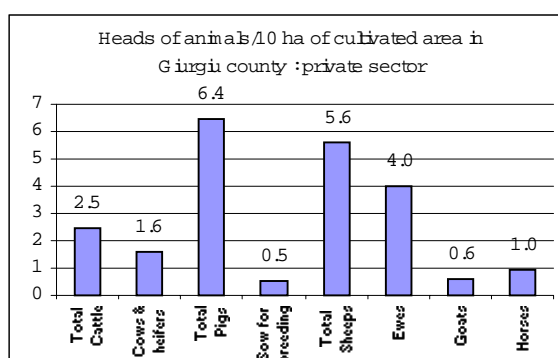
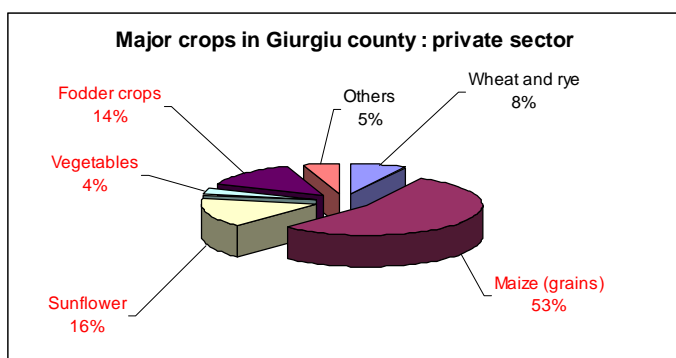
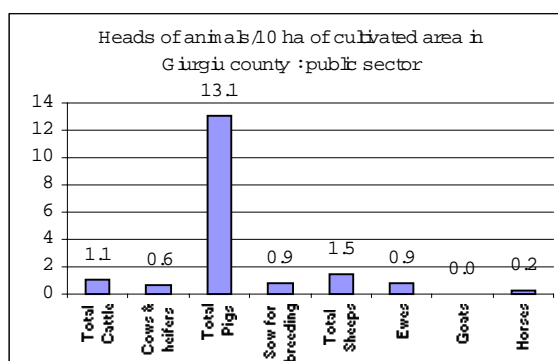
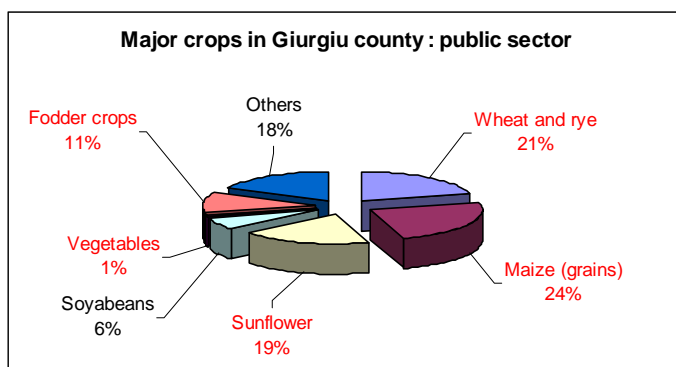
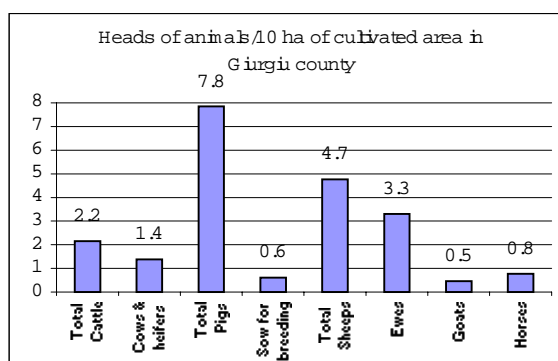
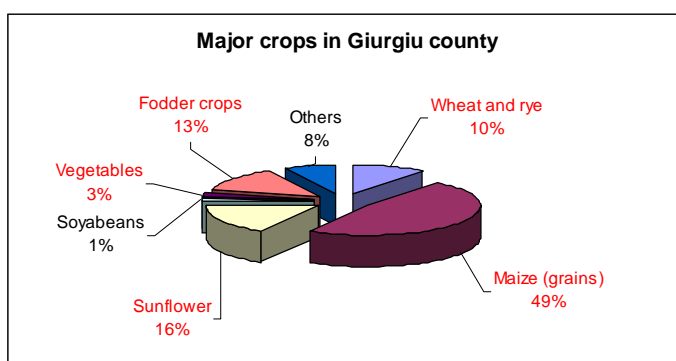

TELEORMAN county

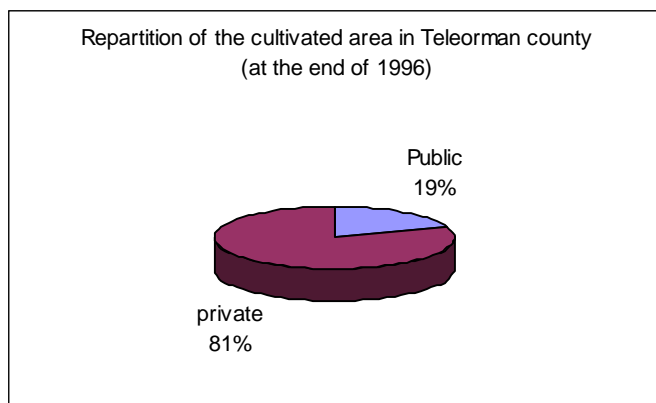

	Teleorman		
	Total	Public	Private
Total Cattle	89000	8000	81000
Cows & heifers	50000	3000	47000
Total Pigs	182000	46000	136000
Sow for breeding	14000	5000	9000
Total Sheep	218000	9000	209000
Ewes	153000	4000	149000
Goats	38000	0	38000
Horses	26000	1000	25000
Total Poultry	2827000	53000	2774000
Laying poultry	2021000	53000	1968000
Cultivated area (ha)	423447	92770	330677

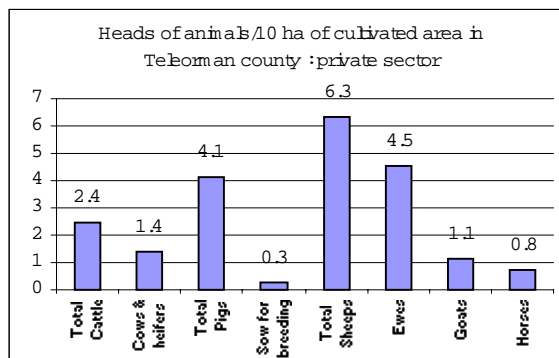
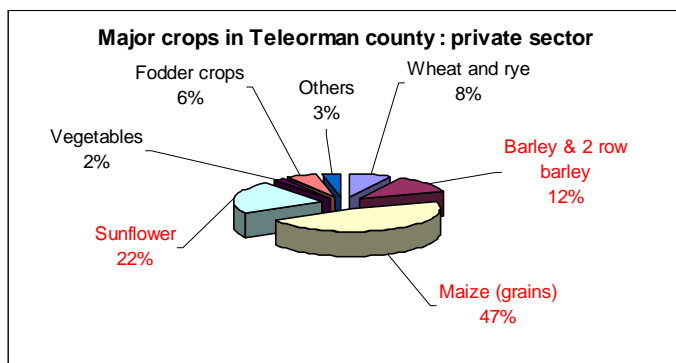
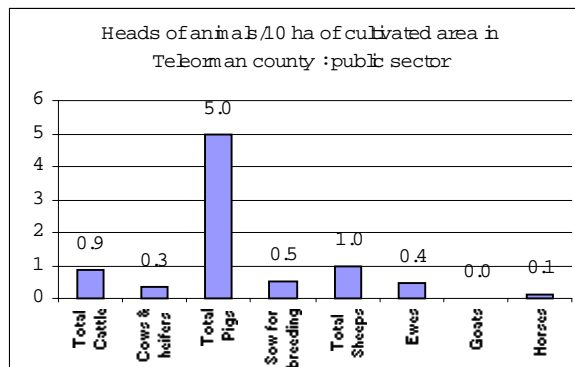
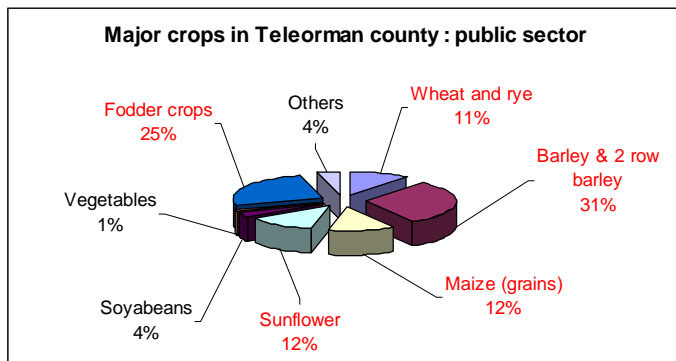
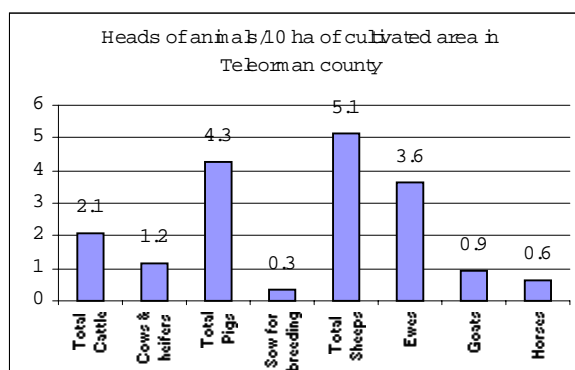
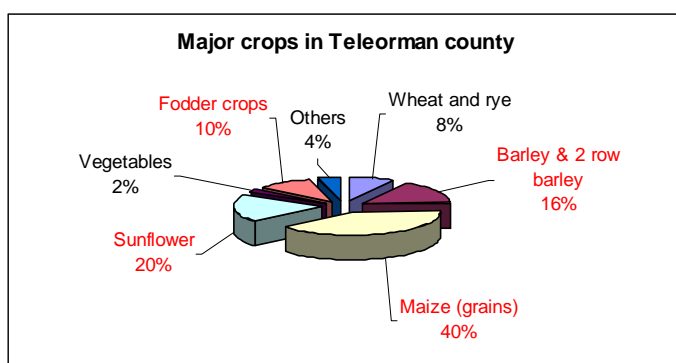

OLT county

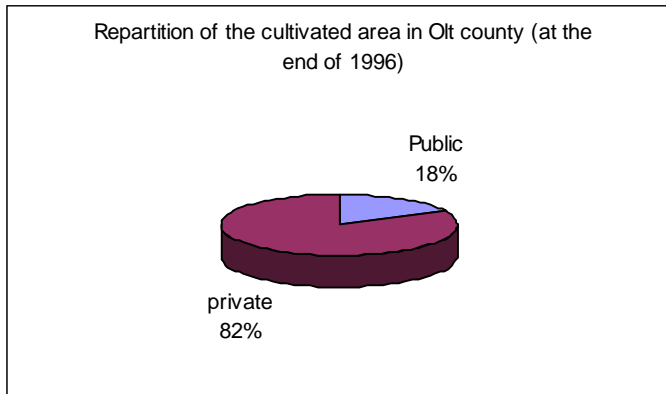

	Olt		
	Total	Public	Private
Total Cattle	68000	5000	63000
Cows & heifers	42000	2000	40000
Total Pigs	216000	80000	136000
Sow for breeding	12000	5000	7000
Total Sheeps	221000	10000	211000
Ewes	162000	5000	157000
Goats	40000	0	40000
Horses	26000	0	26000
Total Poultry	2189000	47000	2142000
Laying poultry	1146000	27000	1119000
Cultivated area (ha)	346393	61491	284902

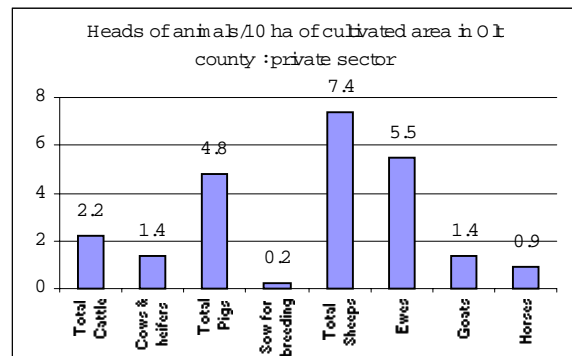
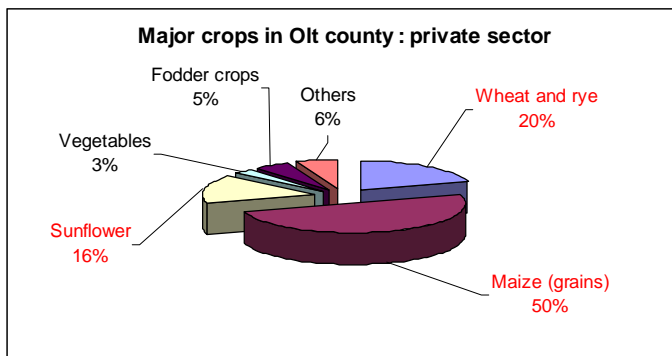
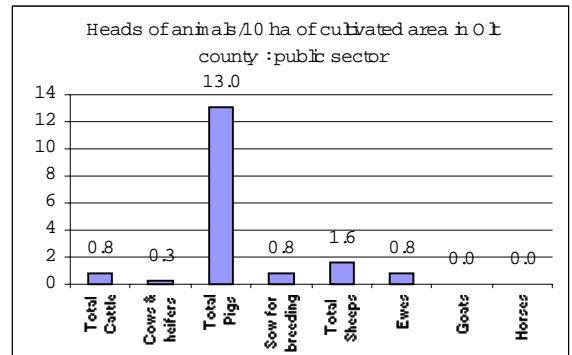
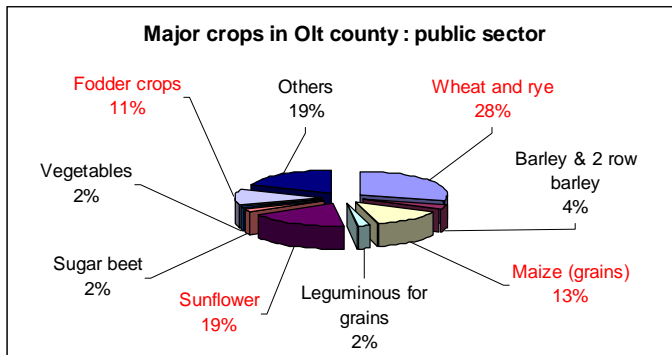
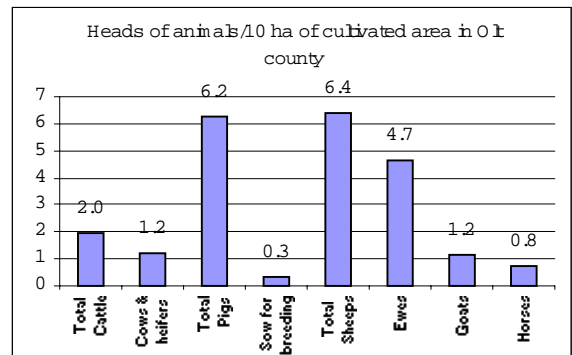
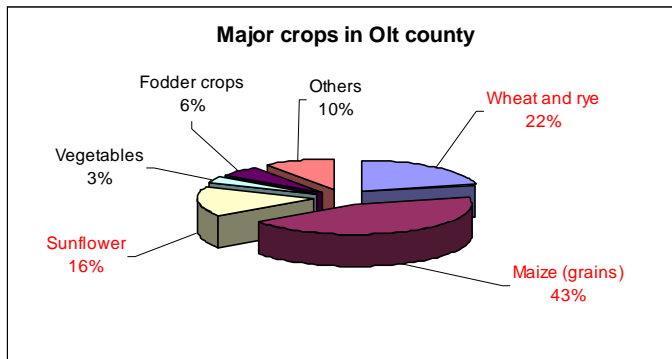

DOLJ county

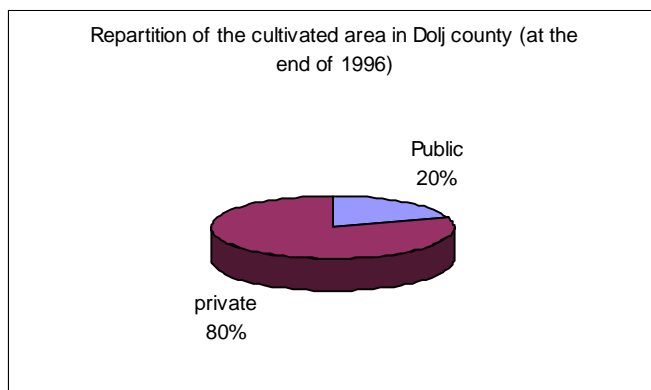

	Dolj		
	Total	Public	Private
Total Cattle	84000	11000	73000
Cows & heifers	53000	4000	49000
Total Pigs	205000	54000	151000
Sow for breeding	16000	6000	10000
Total Sheeps	271000	13000	258000
Ewes	211000	9000	202000
Goats	49000	0	49000
Horses	29000	0	29000
Total Poultry	2982000	385000	2597000
Laying poultry	1455000	142000	1313000
Cultivated area (ha)	414429	84048	330381

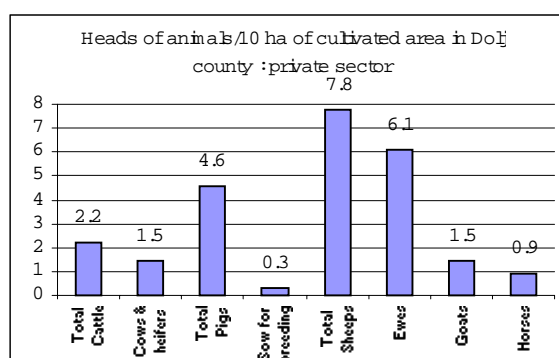
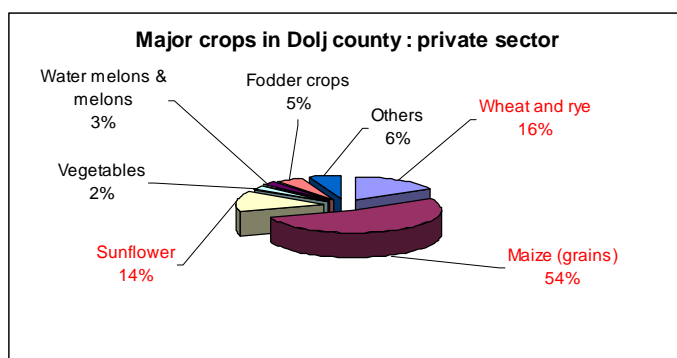
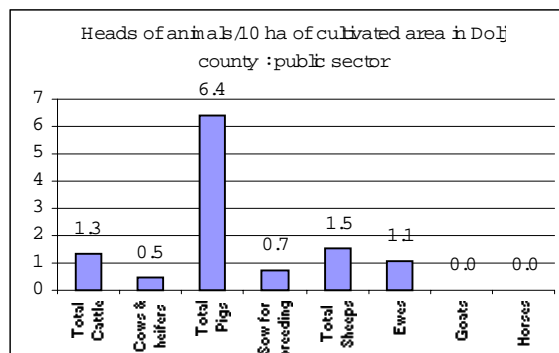
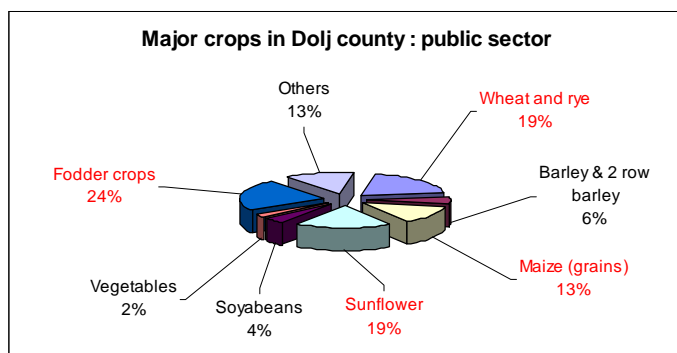
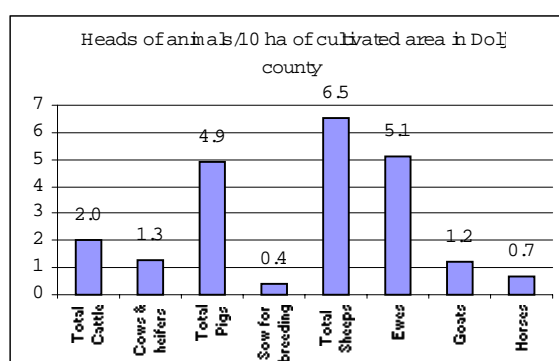
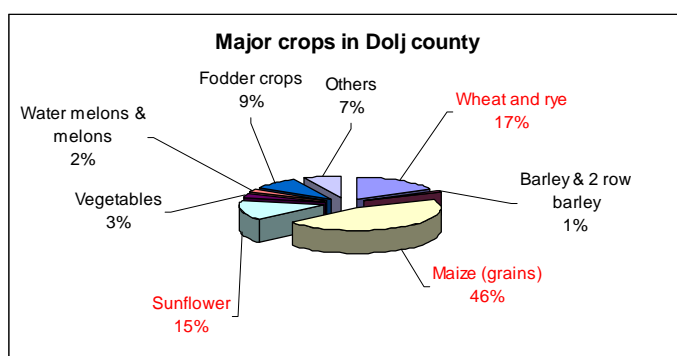

APPENDIX F

Characteristics of soils around PLEVEN

Characteristics of soils around PLEVEN

Measurements (in green) coming from Bulgarian references allow us to draw an overview of soils characteristics (texture, PF curve, soil density, conductivity at saturation).

TRASTENIK : calcaro-calcic chernozem

		Horizons								
		A1 : 0-25 cm	A2 : 25-50 cm	A3 : 50-82 cm	Bk : 82-125 cr	A1 adjusted	A2 adjusted	A3 adjusted	Bk adjusted	
DATA	Diamètre µm	1	22.3	19.1	17.75	19.40	22.30	19.10	17.75	19.40
		2					25.87	22.29	20.61	21.60
DATA		5	30.6	26.5	24.40	24.50	30.60	26.50	24.40	24.50
		10	37.5	31.6	28.35	33.60	37.50	31.60	28.35	33.60
		12								
		14								
		16								
		18								
		20								
		30								
		40								
		50	77.1	70.8	59.90	68.50	77.10	70.80	59.90	68.50
		100								
		200								
		250	94.4	86.4	77.40	82.30				

Between 1 and 5 µm :				
		$y=5.1571 \cdot \ln(x)+22.3$	$y=4.5979 \cdot \ln(x)+19.1$	
		$y=4.1319 \cdot \ln(x)+17.75$		$y=3.1688 \cdot \ln(x)+19.4$

Adjusted texture				
	A1	A2	A3	Bk
	0 - 25 cm	25 - 50 cm	50 - 82 cm	82 - 125 cm
Clay	25.87	22.29	20.61	21.60
Silt	51.23	48.51	39.29	46.90
Sand	22.90	29.20	40.10	31.50

Calcaro-calcic chernozems

DATA	BD fc	FC (%)	WP (%)	SAT (%)	FC (vol)	WP (vol)	SAT (vol)	Sp. Weight	SAT from SP. W
A1	1.25	25.3	11.6	52.8	0.316	0.145	0.660	2.65	0.528
A2	1.22	24.6	11.8	54.1	0.300	0.144	0.660	2.66	0.541
A3	1.2	24.4	12	54.9	0.293	0.144	0.659	2.66	0.549
Bk	1.2	24.8	10.1	55.2	0.298	0.121	0.662	2.68	0.552

SAT=(specific weight-BD)*100/specific weight

Ksat = 173 - 518 cm/day
Silty loam

DABNIK : haplic chernozem (the same soil is found in OBRASTZOV CHIFLIK area)

DATA	Diamètre µm	Horizons					0-28cm adj	28-43 cm adj	43-62 cm adj	62-80 cm adj	100-130 cm adjusted
		0-28 cm	28-43 cm	43-62 cm	62-80 cm	100-130 cm					
	1	38.3	41.1	40.30	38.30	35.80	38.30	41.10	40.30	38.30	35.80
	2						42.61	44.89	44.26	42.74	41.87
	5	48.3	49.9	49.50	48.60	49.90	48.30	49.90	49.50	48.60	49.90
	10	55.6	57.5	58.00	55.90	58.60	55.60	57.50	58.00	55.90	58.60
	12										
	14										
	16										
	18										
	20										
	30										
	40										
	50	89.3	89.1	86.80	90.60	89.80	89.30	89.10	86.80	90.60	89.80
	100										
	200										
	250	97.7	98.1	98.20	97.90	98.10					

Between 1 and 5 µm :
 $y=6.2133 \cdot \ln(x)+38.3$ $y=5.4677 \cdot \ln(x)+41.1$ $y=8.7608 \cdot \ln(x)+35.8$
 $y=5.7163 \cdot \ln(x)+40.3$ $y=6.3997 \cdot \ln(x)+38.3$

Adjusted texture					
	0 - 28 cm	28 - 43 cm	43 - 62 cm	62-80 cm	100-130 cm
Clay	42.61	44.89	44.26	42.74	41.87
Silt	46.69	44.21	42.54	47.86	47.93
Sand	10.70	10.90	13.20	9.40	10.20

Haplic chernosem

DATA		BD fc	FC (%)	WP (%)	SAT (%)	FC (vol)	WP (vol)	SAT (vol)	Sp. Weight	SAT from SP. W
	A1 (0-27 cm)	1.26	29.8	15	51.5	0.375	0.189	0.649	2.6	0.515
	A2 (27-44 cm)	1.37	28.9	16.5	47.3	0.396	0.226	0.648	2.6	0.473
	AB (44-68 cm)	1.42	25.8	17.3	45.8	0.366	0.246	0.650	2.62	0.458
	B1 (68-85 cm)	1.44	25	17.2	45.2	0.360	0.248	0.651	2.63	0.452
	B2 (85-105 cm)	1.45	25	16.1	45.7	0.363	0.233	0.663	2.67	0.457

SAT=(specific weight-BD)*100/specific weight

Ksat = 86 - 346 cm/day
Heavy loamy (black brown clay)

NIKOLAEVO : ortic luvisol

DATA	Diamètre µm	Horizons			0-27 cm adj	27-37 cm adj	37-70 cm adjusted
		0-27 cm	27-37 cm	37-70 cm			
	1	26.2	35.4	49.60	26.20	35.40	49.60
	2				29.95	38.41	52.79
	5	34.9	42.4	57.00	34.90	42.40	57.00
	10	45	49.3	62.70	45.00	49.30	62.70
	12						
	14						
	16						
	18						
	20						
	30						
	40						
	50	84	81.3	87.90	84.00	81.30	87.90
	100						
	200						
	250	98.6	94.9	98.70			

Between 1 and 5 µm :
 $y=5.4056 \cdot \ln(x)+26.2$ $y=4.3493 \cdot \ln(x)+35.4$
 $y=4.5979 \cdot \ln(x)+49.6$

Adjusted texture			
	0 - 27 cm	27 - 37 cm	37 - 70 cm
Clay	29.95	38.41	52.79
Silt	54.05	42.89	35.11
Sand	16.00	18.70	12.10

Ortic luvisols

DATA		BD fc	FC (%)	WP (%)	SAT (%)	FC (vol)	WP (vol)	SAT (vol)	Sp. Weight	SAT from SP. W
	A1 (0-24 cm)	1.26	28.7	12.2	51.3	0.362	0.154	0.646	2.59	0.514
	A2 (24-40 cm)	1.36	28.8	15.4	47.9	0.392	0.209	0.651	2.61	0.479
	B1 (40-72 cm)	1.43	30.3	21.3	46	0.433	0.305	0.658	2.65	0.460
	B2 (72-103 cm)	1.44	28.4	19.4	46.9	0.409	0.279	0.675	2.71	0.469

SAT=(specific weight-BD)*100/specific weight

Ksat = 17 - 34 cm/day
A' : loamy
A2 : heavy loamy

APPENDIX G

Results of simulations

n°	Scenario	Country	Soil	Meteo	Year	Remark	Folder	Sub-Folder	Results
1	MMM Manure	Romania	Bucharest	Fundulea	1969	rainy	Manure	Buca69	Manure\ManureBu69.xls
2	MMM Manure	Romania	Bucharest	Fundulea	1975	average	Manure	Buca75	Manure\ManureBu75.xls
3	MMM Manure	Romania	Fundulea	Fundulea	1969	rainy	Manure	Fundu69	Manure\ManureFu69.xls
4	MMM Manure	Romania	Fundulea	Fundulea	1975	average	Manure	Fundu75	Manure\ManureFu75.xls
5	SWWMM	Romania	Bucharest	Fundulea	1969	rainy	Swm	Buca69	SWM\SWMBu69.xls
6	SWWMM	Romania	Bucharest	Fundulea	1975	average	Swm	Buca75	SWM\SWMBu75.xls
7	SWWMM	Romania	Fundulea	Fundulea	1969	rainy	Swm	Fundu69	SWM\SWMFu69.xls
8	SWWMM	Romania	Fundulea	Fundulea	1975	average	Swm	Fundu75	SWM\SWMFu75.xls
9	SWBW	Romania	Fundulea	Fundulea	1969	rainy	Swbw	SWBW69Fu	SWBW\SWBW69Fu.xls
10	SWBW	Romania	Fundulea	Fundulea	1975	average	Swbw	SWBW75Fu	SWBW\SWBW75Fu.xls
11	SWBW	Romania	Bucharest	Fundulea	1969	rainy	Swbw	SWBW69Bu	SWBW\SWBW69Bu.xls
12	SWBW	Romania	Bucharest	Fundulea	1975	average	Swbw	SWBW75Bu	SWBW\SWBW75Bu.xls
13	SWWMM	Bulgaria	Chelopechene	Pleven	1966	Rainy	Swm	SWMCh66Ple	SWM\SWMCh66Ple.xls
14	SWWMM	Bulgaria	Chelopechene	Pleven	1971	average	Swm	SWMCh71Ple	SWM\SWMCh71Ple.xls
15	SWWMM	Bulgaria	Chelopechene	Obrastzov	1969	rainy	Swm	SWMCh69Obr	SWM\SWMCh69Obr.xls
16	SWWMM	Bulgaria	Chelopechene	Obrastzov	1976	average	Swm	SWMCh76Obr	SWM\SWMCh76Obr.xls
17	SWWMM	Bulgaria	Bojurishte	Pleven	1966	Rainy	Swm	SWMBo66Ple	SWM\SWMBo66Ple.xls
18	SWWMM	Bulgaria	Bojurishte	Pleven	1971	average	Swm	SWMBo71Ple	SWM\SWMBo71Ple.xls
19	SWWMM	Bulgaria	Bojurishte	Obrastzov	1969	rainy	Swm	SWMBo69Obr	SWM\SWMBo69Obr.xls
20	SWWMM	Bulgaria	Bojurishte	Obrastzov	1976	average	Swm	SWMBo76Obr	SWM\SWMBo76Obr.xls
21	WRM	Bulgaria	Bojurishte	Pleven	1966	Rainy	Wcm	Wet66	WCM\WCMBBo71-66Ple.xls
22	WRM	Bulgaria	Bojurishte	Pleven	1967	Dry	Wcm	Dry67	WCM\WCMBBo71-67Ple.xls

n° 1 - Maize and Manure

Soil : Bucharest
Meteo: Fundulea
Year: 1969 - rainy

CROP	from		to		Yield (DM) g/m ²	Rainfall		Drainage		NO3 leaching	
	date	date	date	date		period mm	cumul mm	period mm	cumul mm	period kg N/ha	cumul kg N/ha
bare soil	266	23/09/00	119	30/04/01		437	437	239	239	35	35
Maize	120	01/05/01	263	20/09/01	2299	454	891	2	241	0	35
bare soil	264	21/09/01	119	30/04/02		437	1328	96	337	13	48
Maize	120	01/05/02	263	20/09/02	2231	453	1781	1	338	0	48
bare soil	264	21/09/02	119	30/04/03		437	2218	99	437	13	61
Maize	120	01/05/03	263	20/09/03	2230	454	2672	2	439	1	62
bare soil	264	21/09/03	119	30/04/04		437	3109	106	545	13	75
Maize	120	01/05/04	263	20/09/04	2218	453	3562	1	546	0	75
bare soil	264	21/09/04	119	30/04/05		437	3999	97	643	13	88
Maize	120	01/05/05	263	22/09/05	2230	454	4453	2	645	1	89
bare soil	264	23/09/05	119	30/04/06		437	4890	99	744	13	102
maize	120	01/05/06	263	22/09/06	2230	453	5343	3	747	0	102

days	Rainfall mm/day	Drainage mm/day	Nitrate Leaching g N/day
219	2,00	1,09	159,8
142	3,20	0,01	-
221	1,98	0,43	58,8
142	3,19	0,01	-
221	1,98	0,45	58,8
142	3,20	0,01	7,0
222	1,97	0,48	58,6
142	3,19	0,01	-
221	1,98	0,44	58,8
144	3,15	0,01	6,9
219	2,00	0,45	59,4
144	3,15	0,02	-

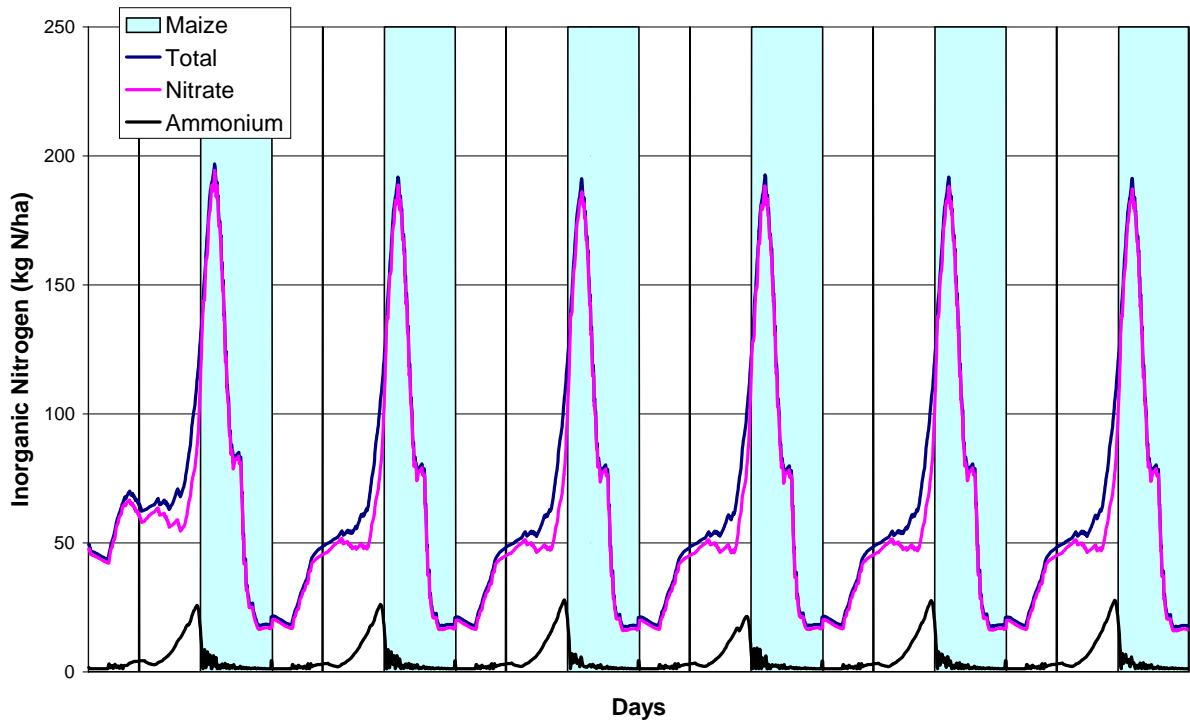
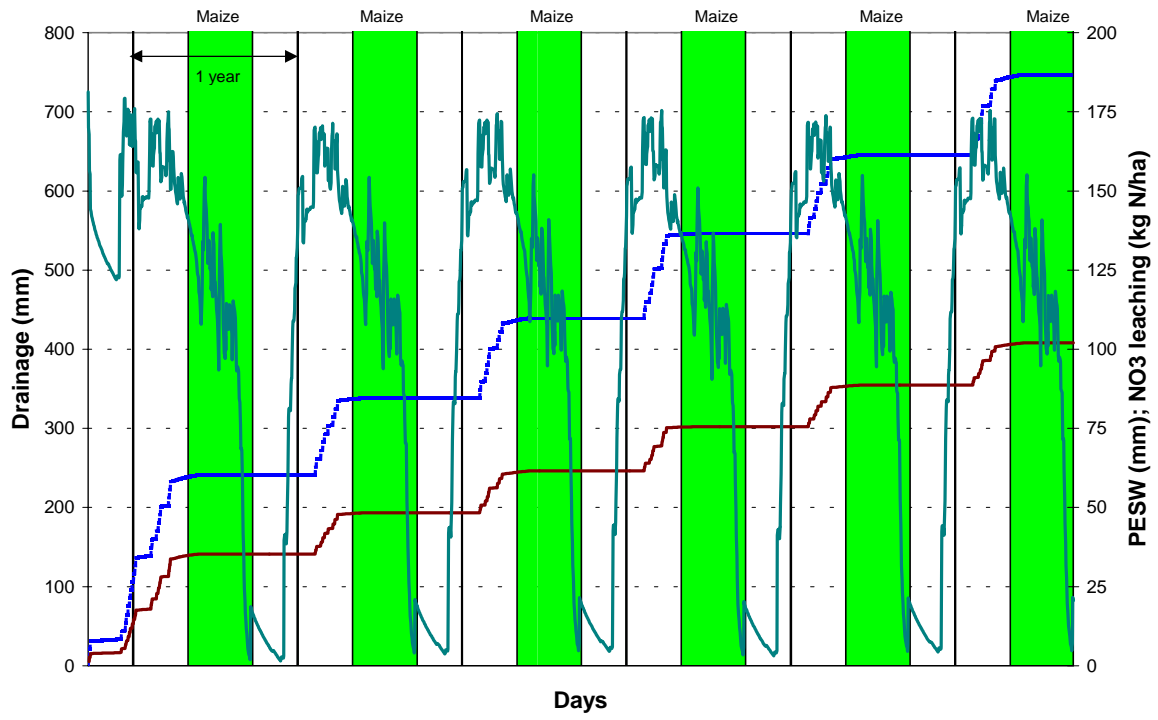

n° 2 - Maize and Manure

Soil : Bucharest
Meteo: Fundulea
Year: 1975 - average

CROP	from		to		Yield (DM) g/m ²	Rainfall		Drainage		NO3 leaching	
						period	cumul	period	cumul	period	cumul
						mm		mm		kg N/ha	
bare soil	266	23/09/00	123	04/05/01		300	300	112	112	14	14
Maize	124	05/05/01	263	20/09/01	2063	276	576	12	124	1	15
bare soil	264	21/09/01	123	04/05/02		301	877	0	124	0	15
Maize	124	05/05/02	263	20/09/02	1829	276	1153	0	124	0	15
bare soil	264	21/09/02	123	04/05/03		300	1453	0	124	0	15
Maize	124	05/05/03	263	20/09/03	1811	276	1729	0	124	0	15
bare soil	264	21/09/03	123	04/05/04		301	2030	0	124	0	15
Maize	124	05/05/04	263	20/09/04	1806	276	2306	0	124	0	15
bare soil	264	21/09/04	123	04/05/05		300	2606	0	124	0	15
Maize	124	05/05/05	263	22/09/05	1804	276	2882	0	124	0	15
bare soil	264	23/09/05	123	04/05/06		300	3182	0	124	0	15
maize	124	05/05/06	265	22/09/06	1804	276	3458	0	124	0	15

days	Rainfall	Drainage	Nitrate Leaching
	mm/day	mm/day	g N/day
223	1,35	0,50	62,8
138	2,00	0,09	7,2
225	1,34	-	-
138	2,00	-	-
225	1,33	-	-
138	2,00	-	-
226	1,33	-	-
138	2,00	-	-
225	1,33	-	-
140	1,97	-	-
223	1,35	-	-
140	1,97	-	-

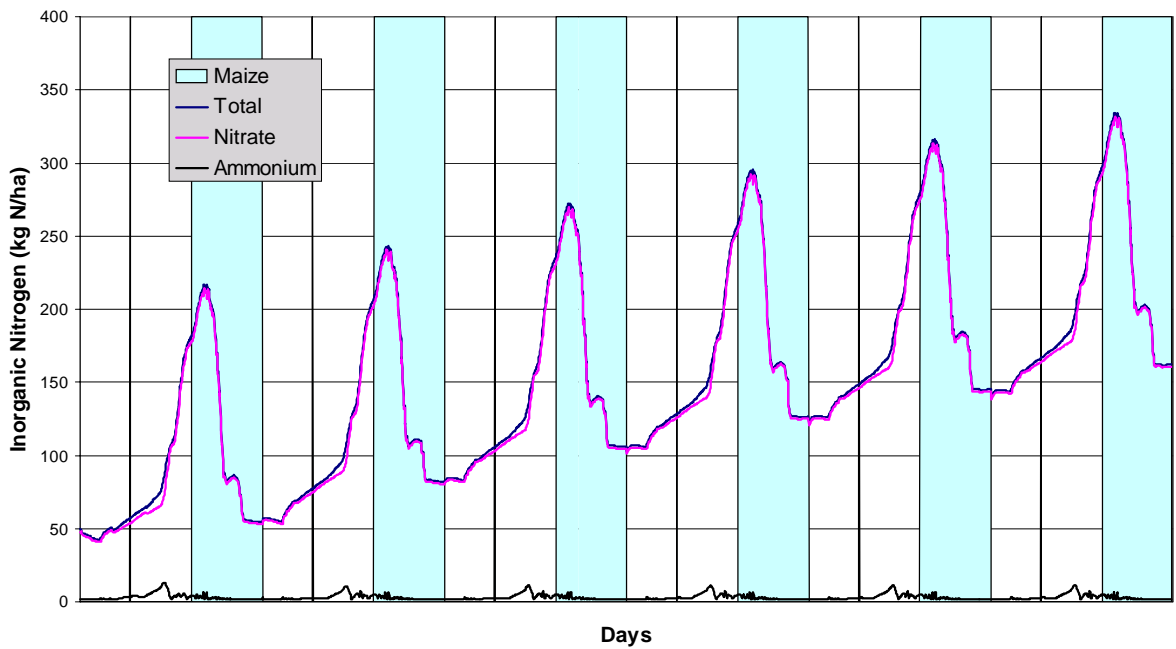
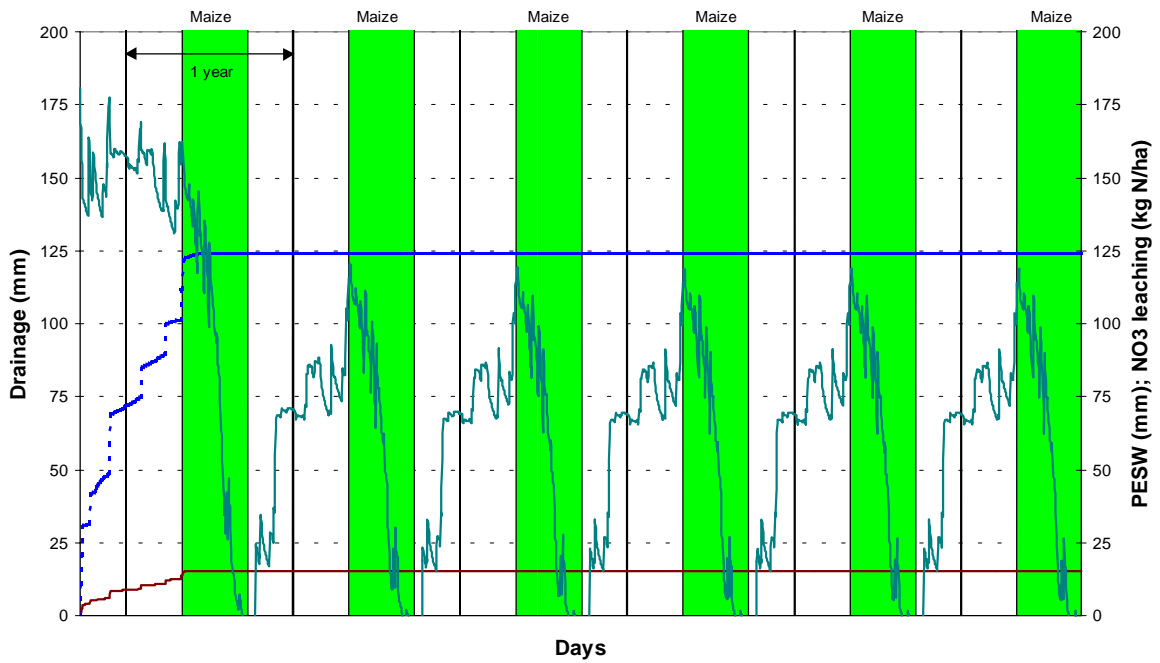

n° 3 - Maize and Manure

Soil : Fundulea
Meteo: Fundulea
Year: 1969 - rainy

CROP	from		to		Yield (DM) g/m ²	Rainfall		Drainage		NO3 leaching	
						period	cumul	period	cumul	period	cumul
						mm		mm		kg N/ha	
bare soil	266	23/09/00	123	03/05/01		437	437	336	336	73	73
Maize	124	04/05/01	265	22/09/01	2526	454	891	87	423	22	95
bare soil	266	23/09/01	123	03/05/02		437	1328	201	624	21	116
Maize	124	04/05/02	265	22/09/02	2428	453	1781	89	713	13	129
bare soil	266	23/09/02	123	03/05/03		437	2218	200	913	19	148
Maize	124	04/05/03	265	22/09/03	2412	454	2672	88	1001	12	160
bare soil	266	23/09/03	123	03/05/04		437	3109	201	1202	21	181
Maize	124	04/05/04	265	22/09/04	2429	453	3562	88	1290	12	193
bare soil	266	23/09/04	123	03/05/05		437	3999	200	1490	20	213
Maize	124	04/05/05	265	22/09/05	2414	454	4453	88	1578	12	225
bare soil	266	23/09/05	123	03/05/06		437	4890	201	1779	21	246
maize	124	04/05/06	265	22/09/06	2430	453	5343	88	1867	12	258

days	Rainfall	Drainage	Nitrate Leaching
	mm/day	mm/day	g N/day
222	1,97	1,51	328,8
141	3,22	0,62	156,0
222	1,97	0,91	94,6
141	3,21	0,63	92,2
222	1,97	0,90	85,6
141	3,22	0,62	85,1
223	1,96	0,90	94,2
141	3,21	0,62	85,1
222	1,97	0,90	90,1
141	3,22	0,62	85,1
222	1,97	0,91	94,6
141	3,21	0,62	85,1

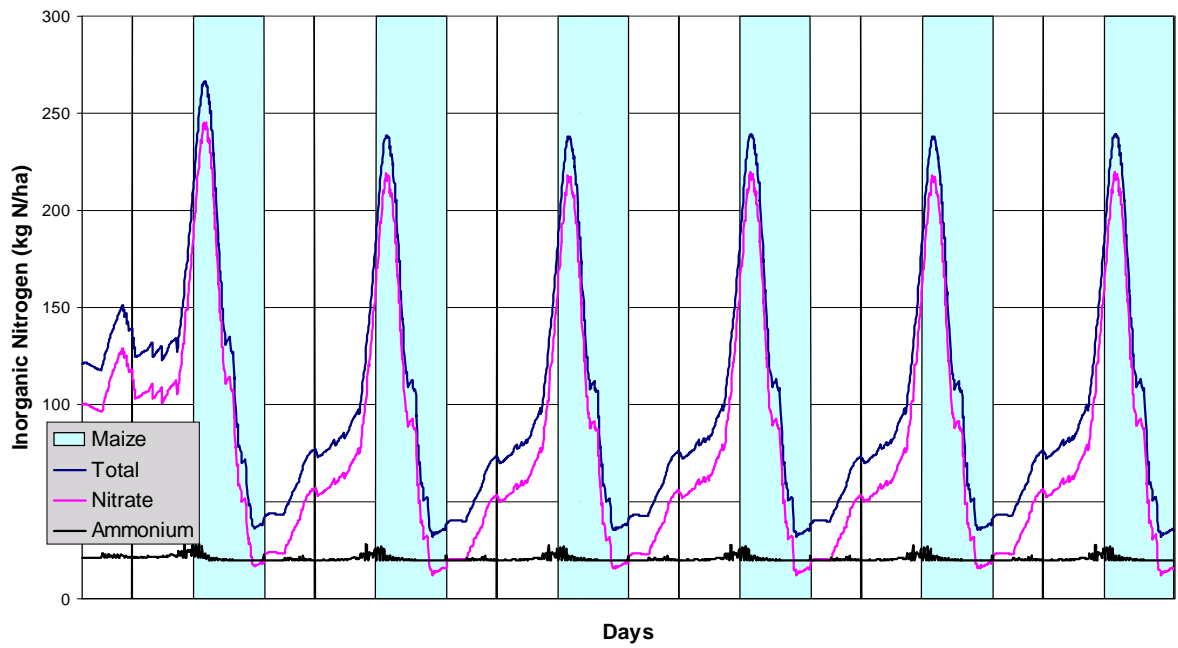
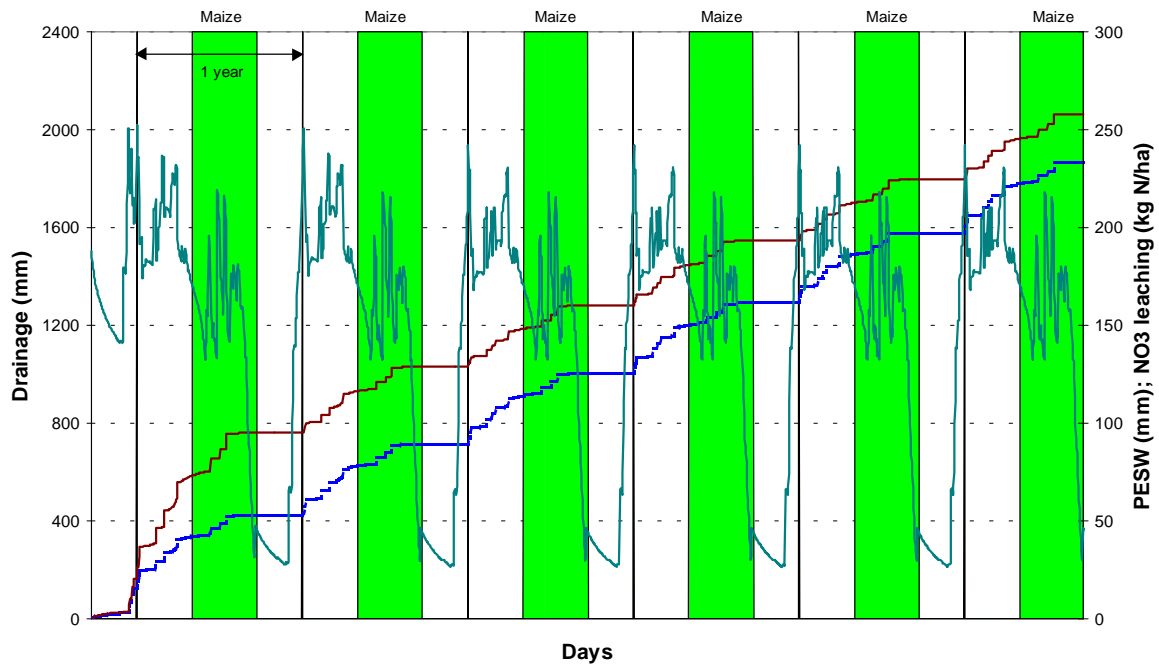

n° 4 - Maize and Manure

Soil : Fundulea
Meteo: Fundulea
Year: 1975 - average

CROP	from		to		Yield (DM) g/m ²	Rainfall		Drainage		NO3 leaching	
						period	cumul	period	cumul	period	cumul
						mm		mm		kg N/ha	
bare soil	266	23/09/00	123	03/05/01		297	297	135	135	22	22
Maize	124	04/05/01	265	22/09/01	2422	279	576	15	150	3	25
bare soil	266	23/09/01	123	03/05/02		297	873	0	150	0	25
Maize	124	04/05/02	265	22/09/02	2274	280	1153	0	150	0	25
bare soil	266	23/09/02	123	03/05/03		300	1453	0	150	0	25
Maize	124	04/05/03	265	22/09/03	2275	276	1729	0	150	0	25
bare soil	266	23/09/03	123	03/05/04		297	2026	0	150	0	25
Maize	124	04/05/04	265	22/09/04	2276	280	2306	0	150	0	25
bare soil	266	23/09/04	123	03/05/05		296	2602	0	150	0	25
Maize	124	04/05/05	265	22/09/05	2277	280	2882	0	150	0	25
bare soil	266	23/09/05	123	03/05/06		297	3179	0	150	0	25
maize	124	04/05/06	265	22/09/06	2269	279	3458	0	150	0	25

days	Rainfall	Drainage	Nitrate Leaching
	mm/day	mm/day	g N/day
222	1,34	0,61	99,1
141	1,98	0,11	21,3
222	1,34	-	-
141	1,99	-	-
222	1,35	-	-
141	1,96	-	-
223	1,33	-	-
141	1,99	-	-
222	1,33	-	-
141	1,99	-	-
222	1,34	-	-
141	1,98	-	-

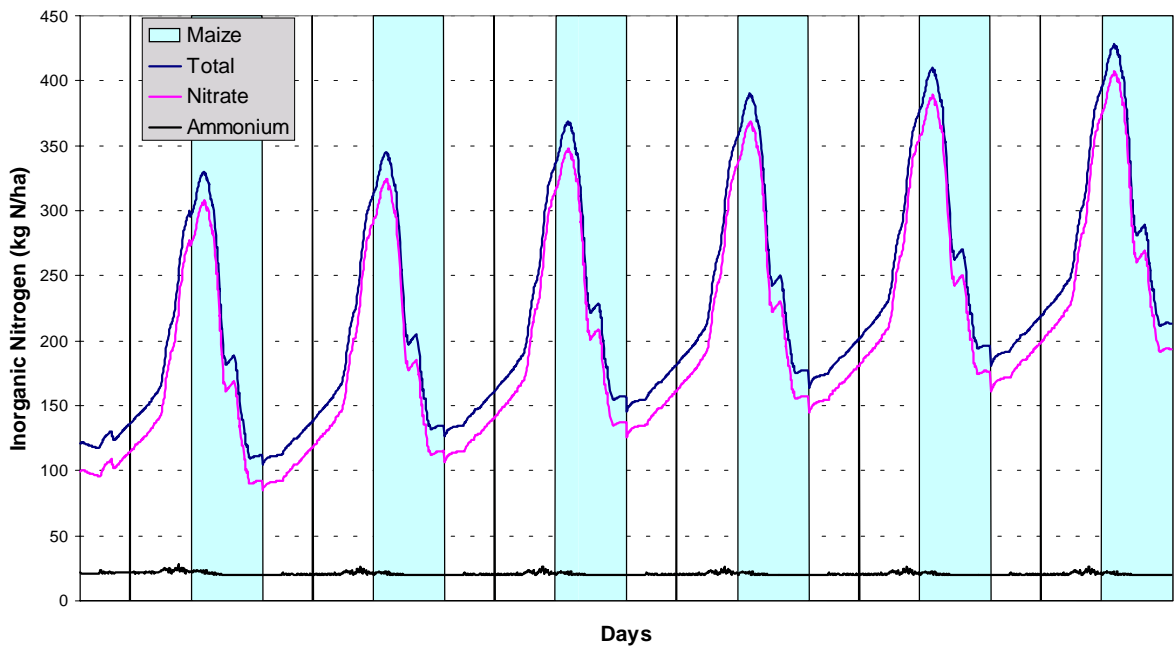
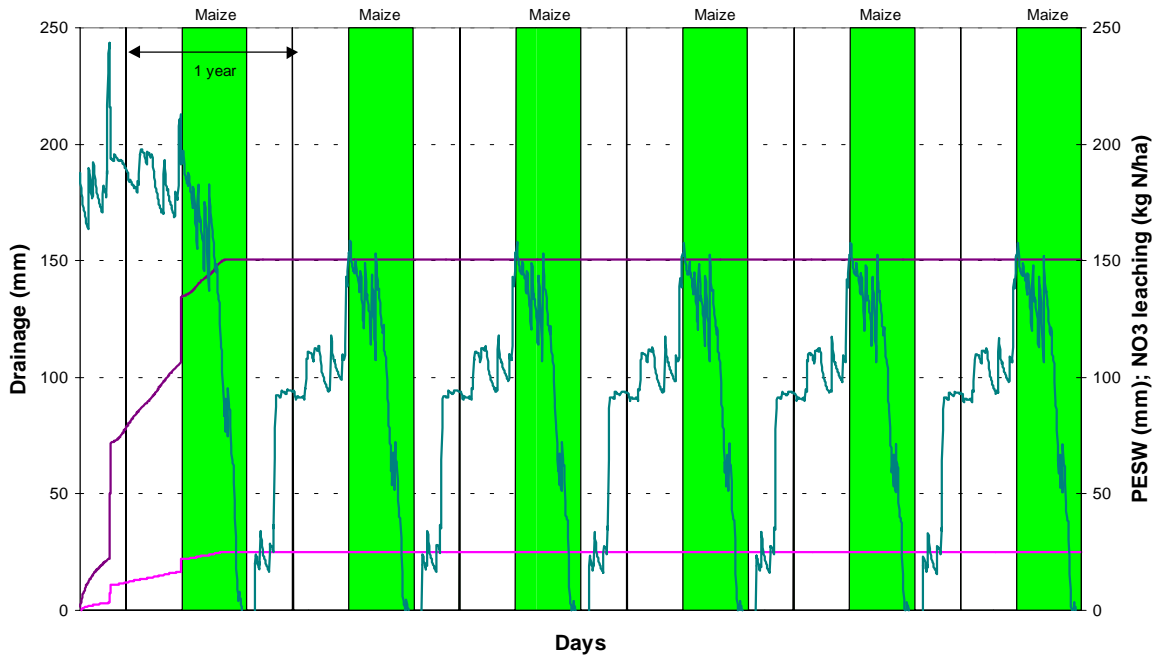

n° 5 – Sunflower Wheat 2x Maize 2x

Soil : Bucharest
Meteo: Fundulea
Year: 1969 - rainy

CROP	from		to		Yield (DM) g/m ²	Rainfall		Drainage		NO3 leaching	
	day	date	day	date		period	cumul	period	cumul	period	cumul
						mm		mm		kg N/ha	
bare soil	221	09/08/00	114	24/04/01		431	431	359	359	29	29
Sunflower	115	25/04/01	260	17/09/01	822	436	867	85	444	1	30
bare soil	261	18/09/01	284	11/10/01		19	886	0	444	0	30
Wheat	285	12/10/01	183	02/07/02	232	668	1554	256	700	13	43
bare soil	184	03/07/02	284	11/10/02		222	1776	140	840	1	44
Wheat	285	12/10/02	183	02/07/03	389	668	2444	297	1137	6	50
bare soil	184	03/07/03	113	23/04/04		653	3097	473	1610	2	52
Maize	114	24/04/04	260	17/09/04	927	437	3534	88	1698	1	53
bare soil	261	18/09/04	113	23/04/05		449	3983	231	1929	3	56
Maize	114	24/04/05	260	17/09/05	830	437	4420	87	2016	1	57
bare soil	261	18/09/05	113	23/04/06		449	4869	234	2250	2	59
Sunflower	114	24/04/06	260	17/09/06	831	437	5306	87	2337	1	60

days	Rainfall	Drainage	Nitrate Leaching
	mm/day	mm/day	g N/day
258	1,67	1,39	112,4
145	3,01	0,59	6,9
23	0,83	-	-
263	2,54	0,97	49,4
100	2,22	1,40	10,0
263	2,54	1,13	22,8
295	2,21	1,60	6,8
146	2,99	0,60	6,8
217	2,07	1,06	13,8
146	2,99	0,60	6,8
217	2,07	1,08	9,2
146	2,99	0,60	6,8

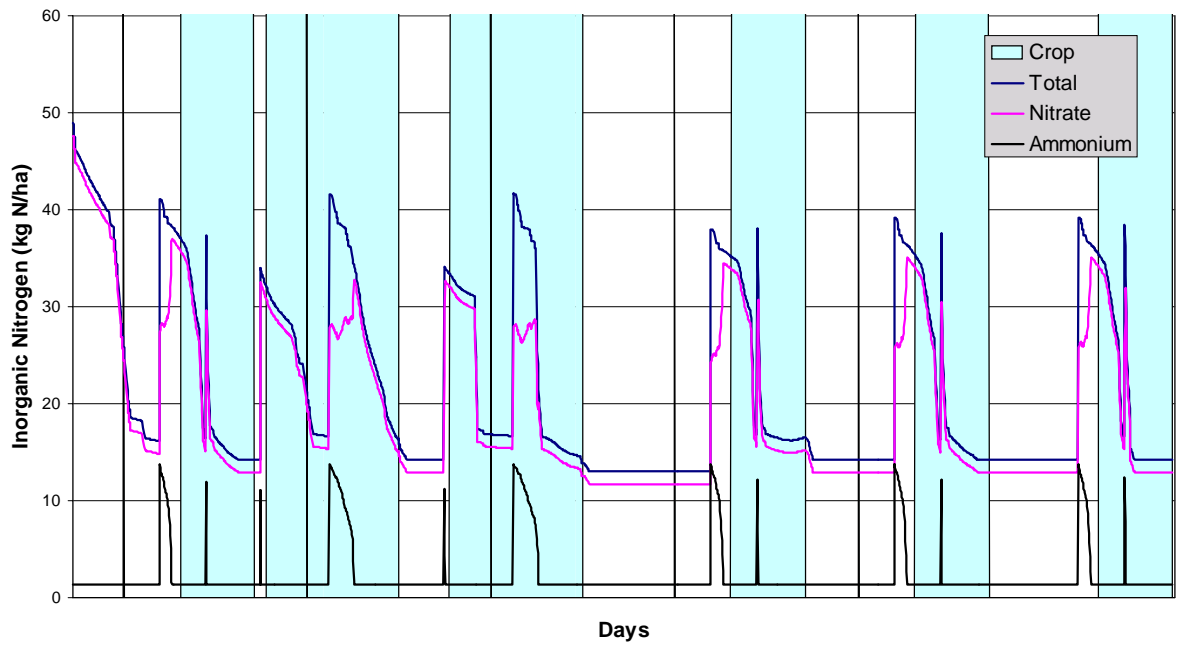
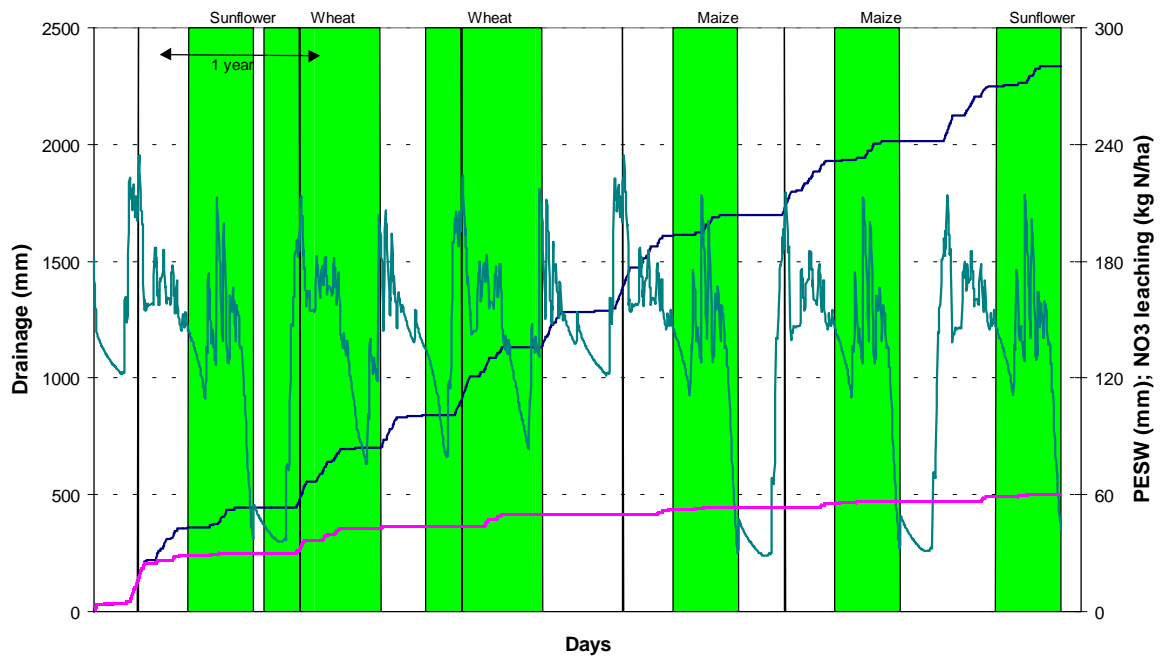

n° 6 – Sunflower Wheat 2x Maize 2x

Soil : Bucharest
Meteo: Fundulea
Year: 1975 - average

CROP	from		to		Yield (DM) g/m ²	Rainfall		Drainage		NO3 leaching	
	day	date	day	date		period	cumul	period	cumul	period	cumul
						mm		mm		kg N/ha	
bare soil	221	09/08/00	114	24/04/01		226	226	134	134	16	16
Sunflower	115	25/04/01	260	17/09/01	1067	350	576	32	166	4	20
bare soil	261	18/09/01	284	11/10/01		25	601	0	166	0	20
Wheat	285	12/10/01	183	02/07/02	500	29	630	0	166	0	20
bare soil	184	03/07/02	284	11/10/02		123	753	0	166	0	20
Wheat	285	12/10/02	183	02/07/03	622	453	1206	26	192	2	22
bare soil	184	03/07/03	113	23/04/04		326	1532	54	246	0	22
Maize	114	24/04/04	260	17/09/04	973	350	1882	31	277	2	24
bare soil	261	18/09/04	113	23/04/05		226	2108	0	277	0	24
Maize	114	24/04/05	260	17/09/05	940	350	2458	0	277	0	24
bare soil	261	18/09/05	113	23/04/06		226	2684	0	277	0	24
Sunflower	114	24/04/06	260	17/09/06	926	351	3035	0	277	0	24

days	Rainfall	Drainage	Nitrate Leaching
	mm/day	mm/day	g N/day
258	0,88	0,52	62,0
145	2,41	0,22	27,6
23	1,09	-	-
263	0,11	-	-
100	1,23	-	-
263	1,72	0,10	7,6
295	1,11	0,18	-
146	2,40	0,21	13,7
217	1,04	-	-
146	2,40	-	-
217	1,04	-	-
146	2,40	-	-

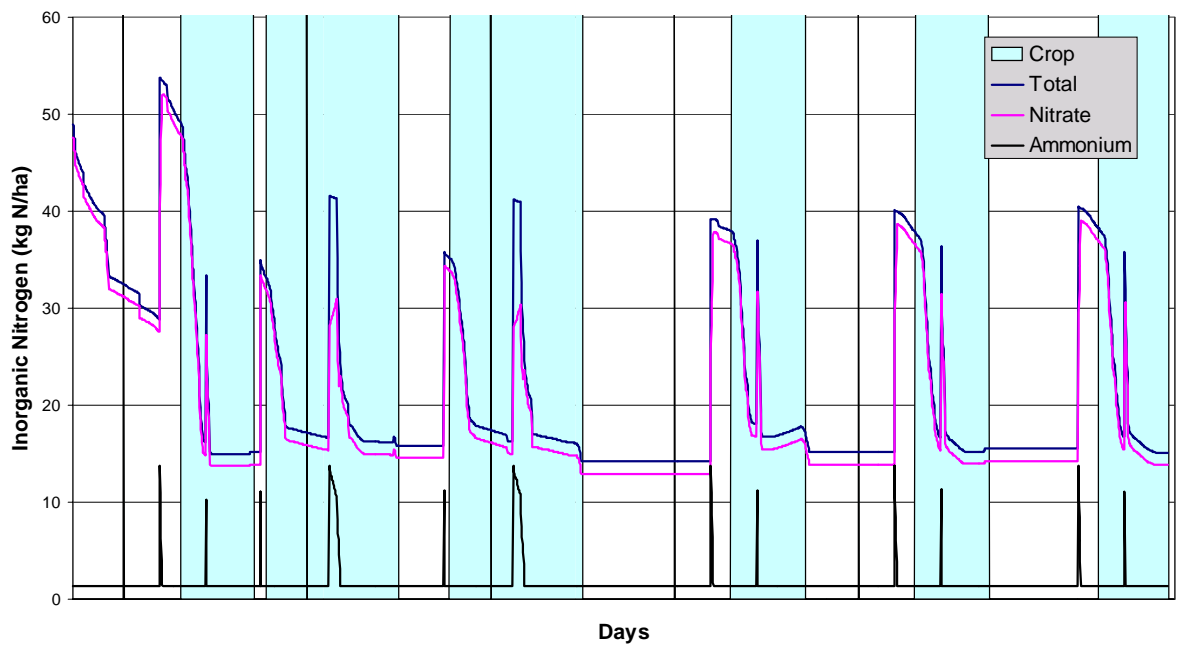
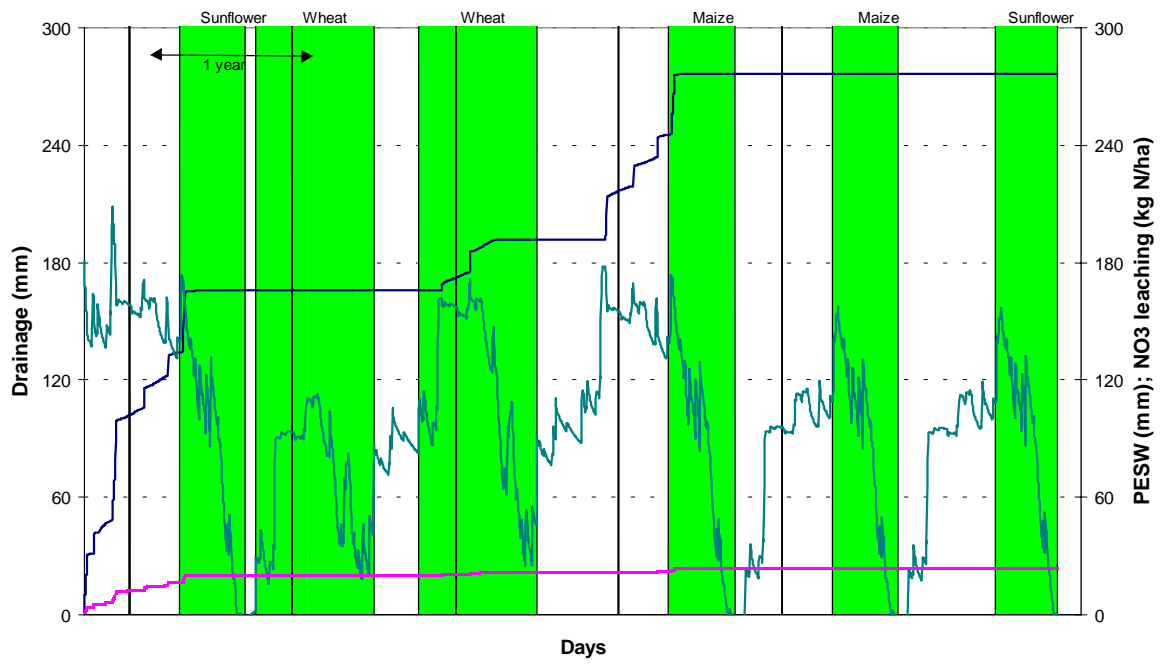

n° 7 – Sunflower Wheat 2x Maize 2x

Soil : Fundulea
Meteo: Fundulea
Year: 1969 - rainy

CROP	from		to		Yield (DM) g/m ²	Rainfall		Drainage		NO3 leaching	
	day	date	day	date		period	cumul	period	cumul	period	cumul
						mm		mm		kg N/ha	
bare soil	221	09/08/00	114	24/04/01		489	489	345	345	64	64
Sunflower	115	25/04/01	260	17/09/01	1588	437	926	88	433	3	67
bare soil	261	18/09/01	284	11/10/01		19	945	0	433	0	67
Wheat	285	12/10/01	183	02/07/02	598	667	1612	207	640	6	73
bare soil	184	03/07/02	284	11/10/02		223	1835	82	722	1	74
Wheat	285	12/10/02	183	02/07/03	485	668	2503	306	1028	8	82
bare soil	184	03/07/03	113	23/04/04		653	3156	447	1475	27	109
Maize	114	24/04/04	260	17/09/04	1429	437	3593	88	1563	1	110
bare soil	261	18/09/04	113	23/04/05		449	4042	199	1762	2	112
Maize	114	24/04/05	260	17/09/05	1177	436	4478	88	1850	1	113
bare soil	261	18/09/05	113	23/04/06		450	4928	201	2051	3	116
Sunflower	114	24/04/06	260	17/09/06	1145	436	5364	90	2141	1	117

days	Rainfall	Drainage	Nitrate Leaching
	mm/day	mm/day	g N/day
258	1,90	1,34	248,1
145	3,01	0,61	20,7
23	0,83	-	-
263	2,54	0,79	22,8
100	2,23	0,82	10,0
263	2,54	1,16	30,4
295	2,21	1,52	91,5
146	2,99	0,60	6,8
217	2,07	0,92	9,2
146	2,99	0,60	6,8
217	2,07	0,93	13,8
146	2,99	0,62	6,8

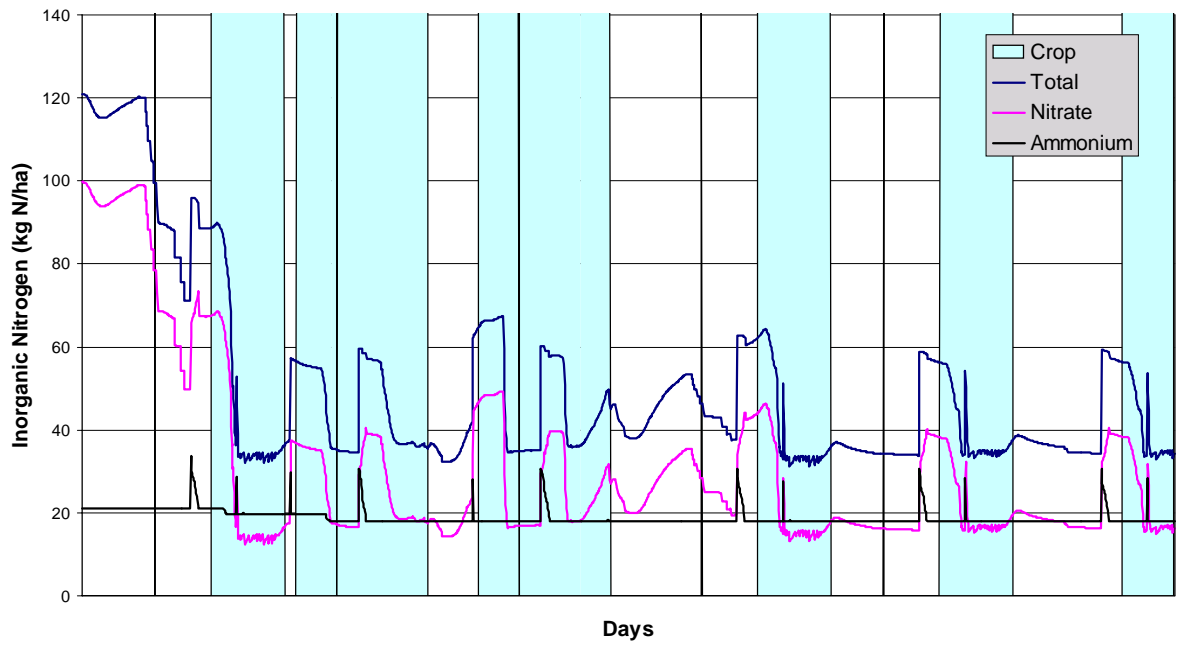
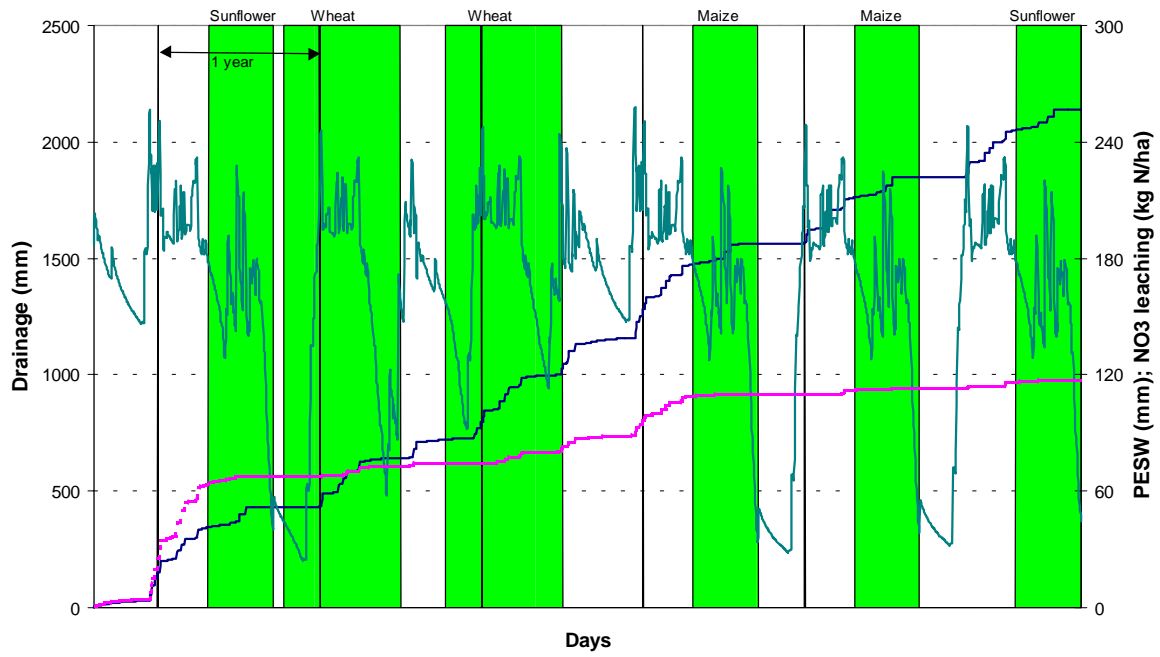

n° 8 – Sunflower Wheat 2x Maize 2x

Soil : Fundulea
Meteo: Fundulea
Year: 1975 - average

CROP	from		to		Yield (DM) g/m ²	Rainfall		Drainage		NO3 leaching	
	day	month/year	day	month/year		period	cumul	period	cumul	period	cumul
						mm		mm		kg N/ha	
bare soil	221	09/08/00	114	24/04/01		267	267	114	114	18	18
Sunflower	115	25/04/01	260	17/09/01	1691	351	618	37	151	7	25
bare soil	261	18/09/01	284	11/10/01		24	642	0	151	0	25
Wheat	285	12/10/01	183	02/07/02	514	131	773	0	151	0	25
bare soil	184	03/07/02	284	11/10/02		124	897	0	151	0	25
Wheat	285	12/10/02	183	02/07/03	1099	453	1350	4	155	0	25
bare soil	184	03/07/03	113	23/04/04		325	1675	7	162	1	26
Maize	114	24/04/04	260	17/09/04	1595	350	2025	36	198	2	28
bare soil	261	18/09/04	113	23/04/05		227	2252	0	198	0	28
Maize	114	24/04/05	260	17/09/05	1136	350	2602	0	198	0	28
bare soil	261	18/09/05	113	23/04/06		226	2828	0	198	0	28
Sunflower	114	24/04/06	260	17/09/06	1123	350	3178	0	198	0	28

days	Rainfall	Drainage	Nitrate Leaching
	mm/day	mm/day	g N/day
258	1,03	0,44	69,8
145	2,42	0,26	48,3
23	1,04	-	-
263	0,50	-	-
100	1,24	-	-
263	1,72	0,02	-
295	1,10	0,02	3,4
146	2,40	0,25	13,7
217	1,05	-	-
146	2,40	-	-
217	1,04	-	-
146	2,40	-	-

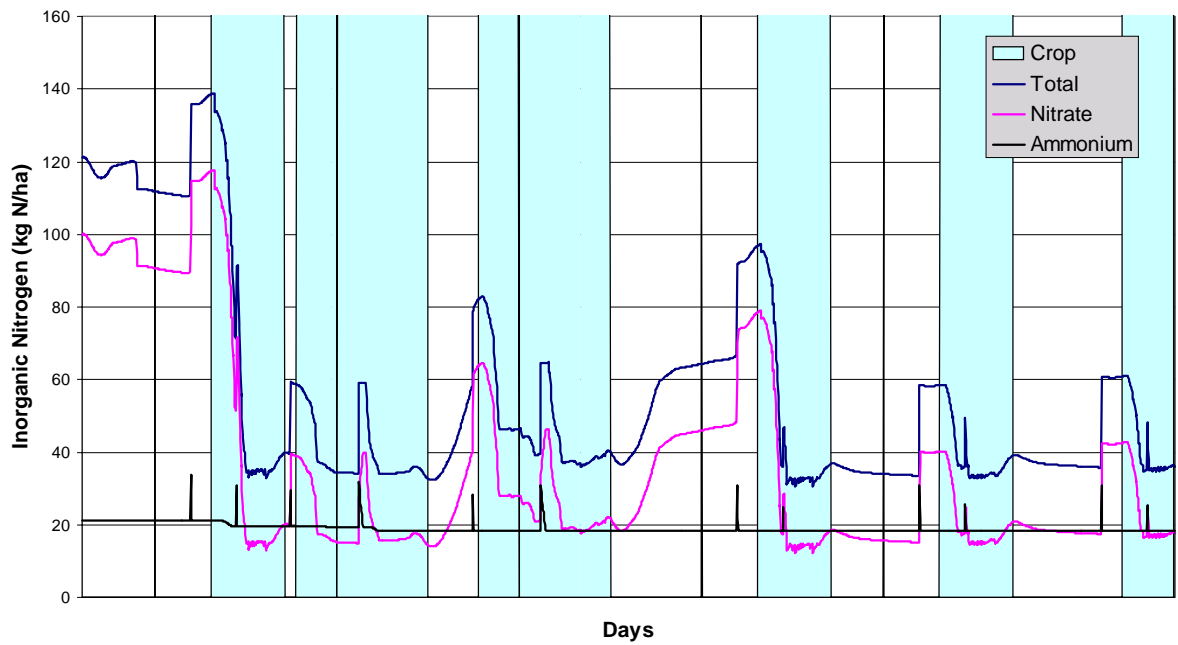
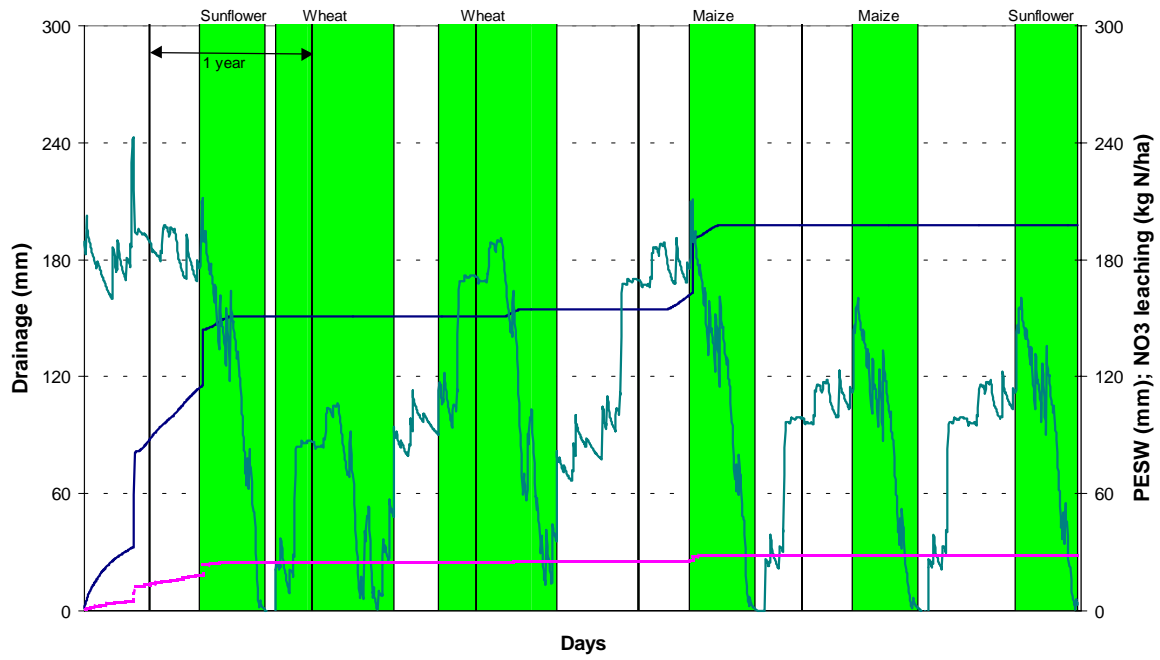

n° 9 – Sunflower Wheat Beet Wheat

Soil : Fundulea
Meteo: Fundulea
Year: 1969 - rainy

CROP	from		to		Yield (DM) g/m ²	Rainfall		Drainage		NO3 leaching	
						period	cumul	period	cumul	period	cumul
						mm		mm		kg N/ha	
bare soil	184	03/07/00	113	23/04/01		653	653	433	433	81	81
Sunflower	114	24/04/01	260	17/09/01	1817	437	1090	82	515	3	84
bare soil	261	18/09/01	286	13/10/01		19	1109	0	515	0	84
Wheat	287	14/10/01	183	02/07/02	868	667	1776	205	720	15	99
bare soil	184	03/07/02	123	03/05/03		654	2430	374	1094	5	104
Sugar Beet	124	04/05/03	260	17/09/03	3714	431	2861	152	1246	1	105
bare soil	261	18/09/03	286	13/10/03		20	2881	0	1246	0	105
Wheat	287	14/10/03	183	02/07/04	898	667	3548	193	1439	4	109
bare soil	184	03/07/04	113	23/04/05		654	4202	379	1818	19	128
Sunflower	114	24/04/05	260	17/09/05	1628	436	4638	89	1907	2	130

days	Rainfall	Drainage	Nitrate Leaching
	mm/day	mm/day	g N/day
294	2,22	1,47	275,5
146	2,99	0,56	20,5
25	0,76	-	-
261	2,56	0,79	57,5
304	2,15	1,23	16,4
136	3,17	1,12	7,4
25	0,80	-	-
262	2,55	0,74	15,3
294	2,22	1,29	64,6
146	2,99	0,61	13,7

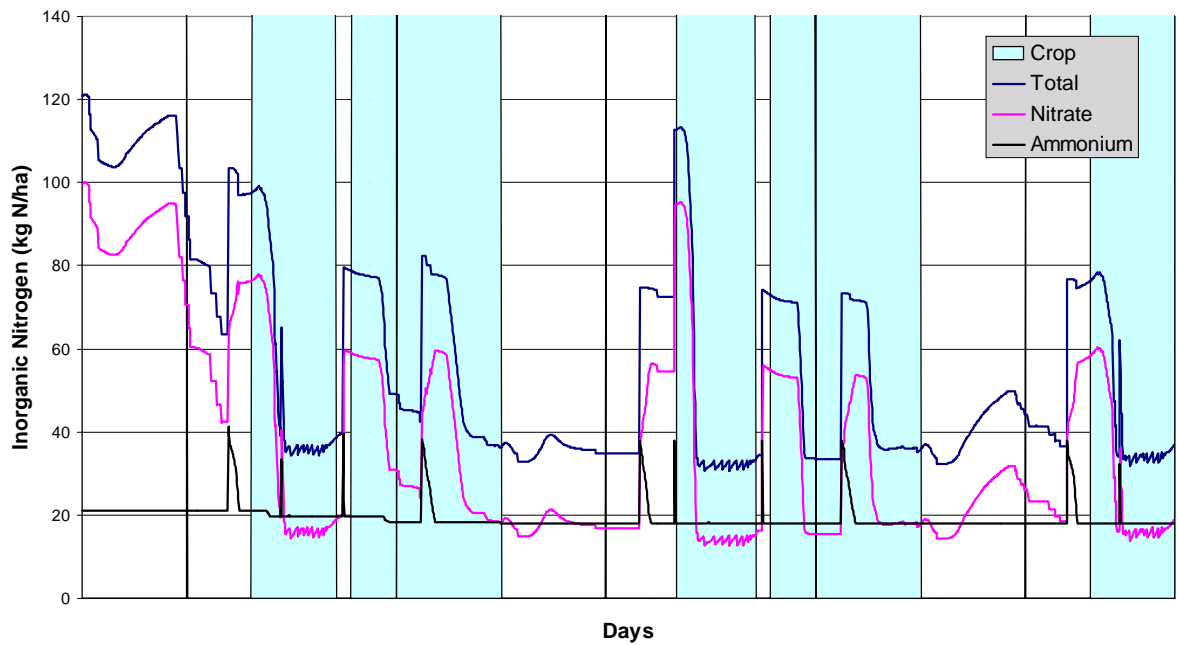
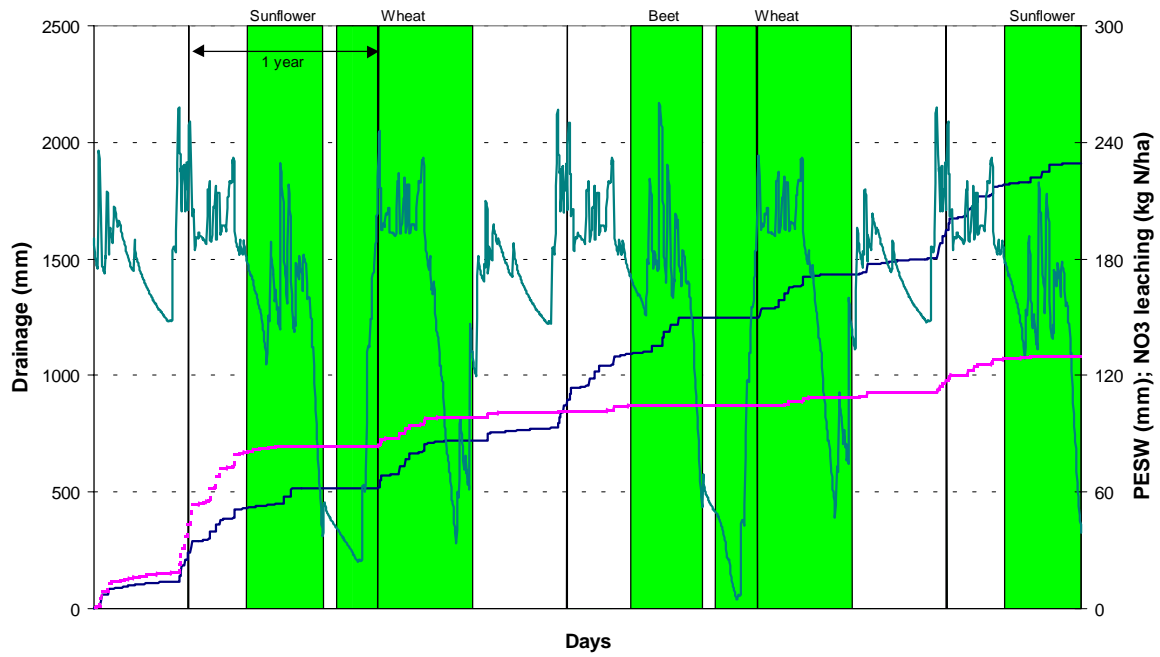

n° 10 – Sunflower Wheat Beet Wheat

Soil : Fundulea
Meteo: Fundulea
Year: 1975 - average

CROP	from		to		Yield (DM) g/m ²	Rainfall		Drainage		NO3 leaching	
						period	cumul	period	cumul	period	cumul
						mm		mm		kg N/ha	
bare soil	184	03/07/00	113	23/04/01		326	326	116	116	18	18
Sunflower	114	24/04/01	260	17/09/01	2015	350	676	36	152	7	25
bare soil	261	18/09/01	286	13/10/01		31	707	0	152	0	25
Wheat	287	14/10/01	183	02/07/02	790	290	997	0	152	0	25
bare soil	184	03/07/02	123	03/05/03		301	1298	44	196	4	29
Sugar Beet	124	04/05/03	260	17/09/03	3875	276	1574	39	235	0	29
bare soil	261	18/09/03	286	13/10/03		31	1605	0	235	0	29
Wheat	287	14/10/03	183	02/07/04	769	290	1895	0	235	0	29
bare soil	184	03/07/04	113	23/04/05		481	2376	18	253	2	31
Sunflower	114	24/04/05	260	17/09/05	1849	351	2727	36	289	4	35

days	Rainfall	Drainage	Nitrate Leaching
	mm/day	mm/day	g N/day
294	1,11	0,39	61,2
146	2,40	0,25	47,9
25	1,24	-	-
261	1,11	-	-
304	0,99	0,14	13,2
136	2,03	0,29	-
25	1,24	-	-
262	1,11	-	-
294	1,64	0,06	6,8
146	2,40	0,25	27,4

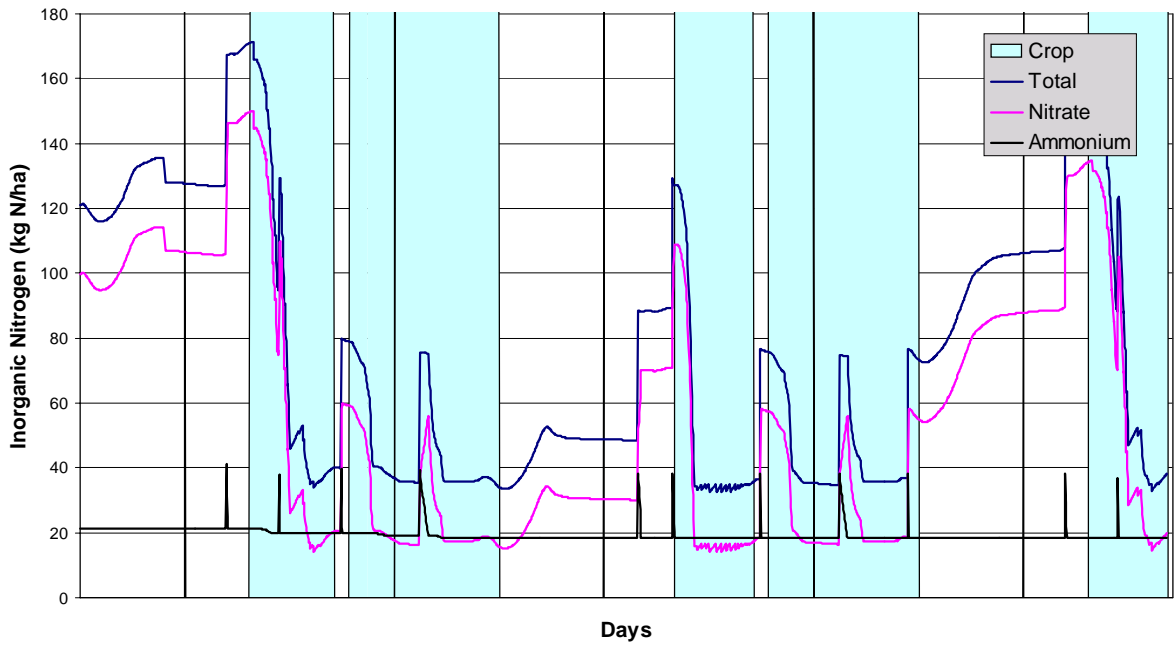
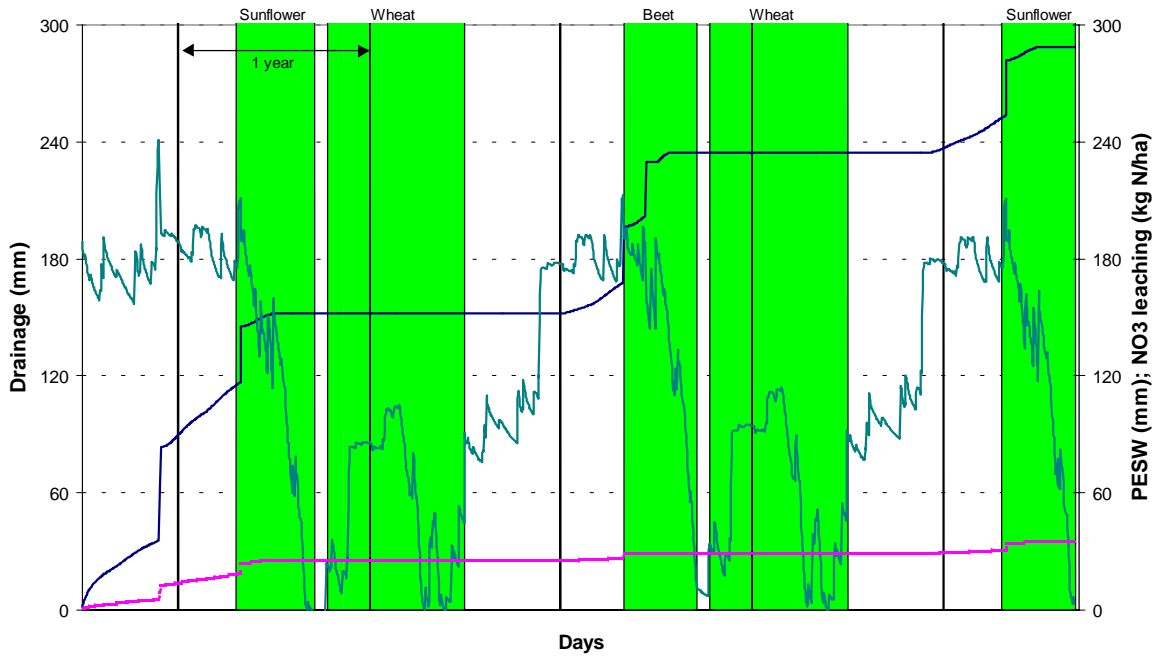

n° 11 – Sunflower Wheat Beet Wheat

Soil : Bucharest
Meteo: Fundulea
Year: 1969 - rainy

CROP	from		to		Yield (DM) g/m ²	Rainfall		Drainage		NO3 leaching	
						period	cumul	period	cumul	period	cumul
						mm		mm		kg N/ha	
bare soil	184	03/07/00	113	23/04/01		653	653	458	458	32	32
Sunflower	114	24/04/01	260	17/09/01	1391	437	1090	74	532	1	33
bare soil	261	18/09/01	286	13/10/01		19	1109	0	532	0	33
Wheat	287	14/10/01	183	02/07/02	337	667	1776	238	770	26	59
bare soil	184	03/07/02	123	03/05/03		656	2432	446	1216	6	65
Sugar Beet	124	04/05/03	260	17/09/03	3714	429	2861	180	1396	1	66
bare soil	261	18/09/03	286	13/10/03		20	2881	0	1396	0	66
Wheat	287	14/10/03	183	02/07/04	842	667	3548	231	1627	7	73
bare soil	184	03/07/04	113	23/04/05		654	4202	386	2013	3	76
Sunflower	114	24/04/05	260	17/09/05	1282	436	4638	77	2090	0	76

days	Rainfall	Drainage	Nitrate Leaching
	mm/day	mm/day	g N/day
294	2,22	1,56	108,8
146	2,99	0,51	6,8
25	0,76	-	-
261	2,56	0,91	99,6
304	2,16	1,47	19,7
136	3,15	1,32	7,4
25	0,80	-	-
262	2,55	0,88	26,7
294	2,22	1,31	10,2
146	2,99	0,53	-

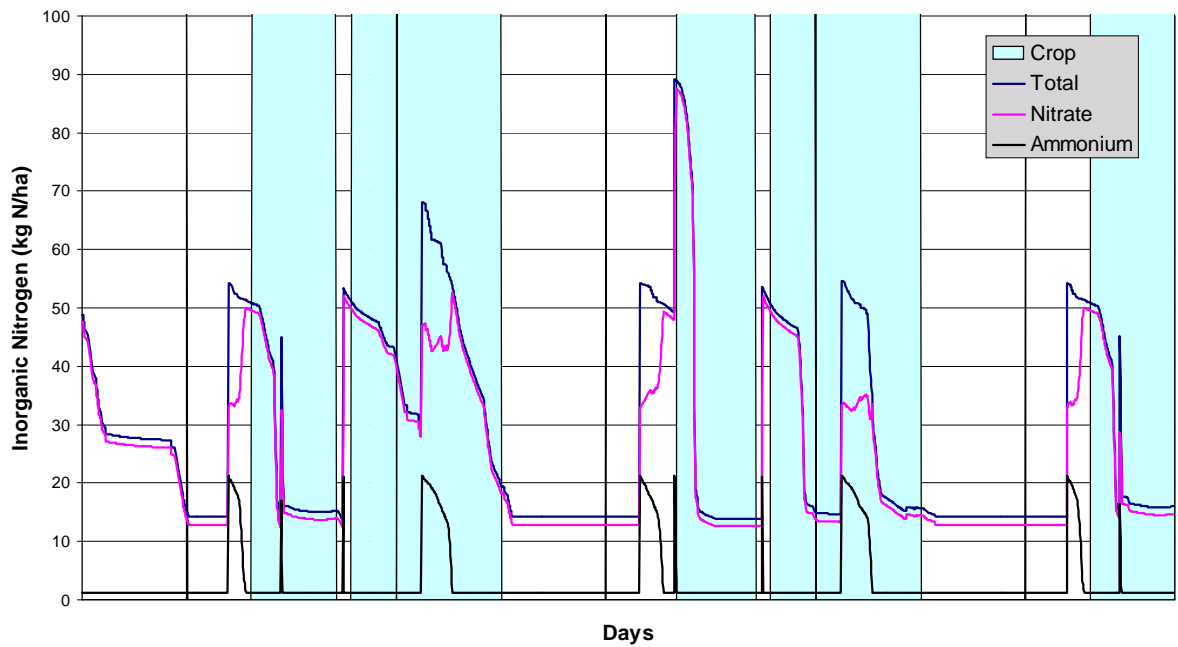
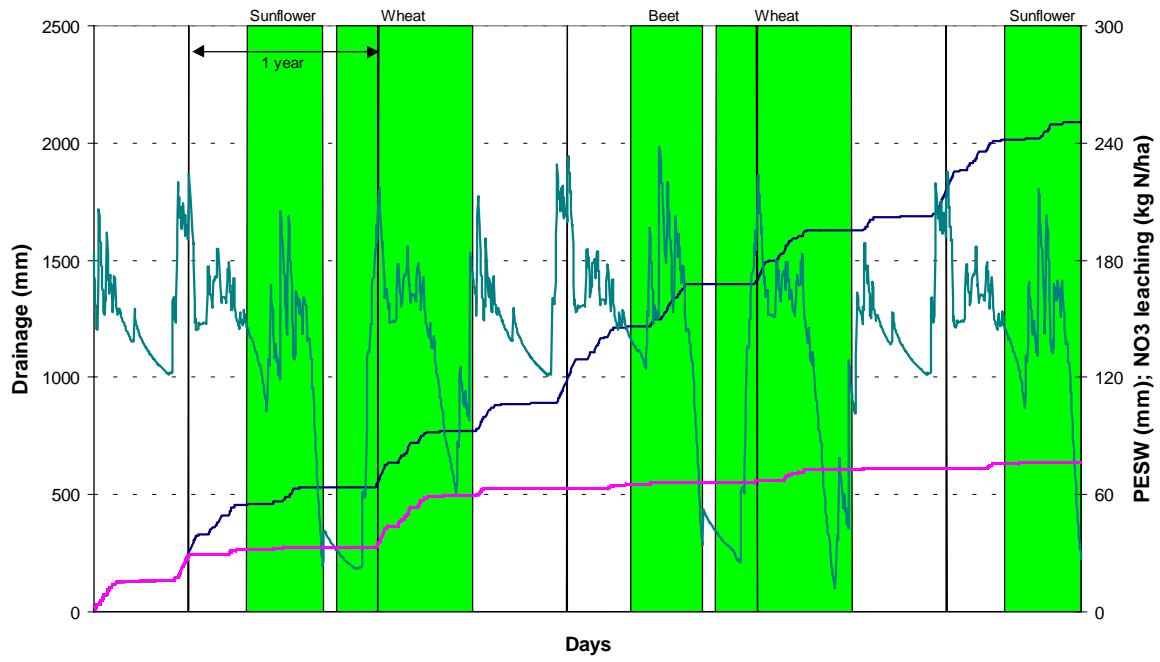

n° 12 – Sunflower Wheat Beet Wheat

Soil : Bucharest
Meteo: Fundulea
Year: 1975 - average

CROP	from		to		Yield (DM) g/m ²	Rainfall		Drainage		NO3 leaching	
						period	cumul	period	cumul	period	cumul
						mm		mm		kg N/ha	
bare soil	184	03/07/00	113	23/04/01		326	326	145	145	17	17
Sunflower	114	24/04/01	260	17/09/01	1348	350	676	32	177	4	21
bare soil	261	18/09/01	286	13/10/01		31	707	0	177	0	21
Wheat	287	14/10/01	183	02/07/02	842	393	1100	0	177	0	21
bare soil	184	03/07/02	123	03/05/03		300	1400	55	232	2	23
Sugar Beet	124	04/05/03	260	17/09/03	3875	276	1676	50	282	1	24
bare soil	261	18/09/03	286	13/10/03		32	1708	0	282	0	24
Wheat	287	14/10/03	183	02/07/04	894	392	2100	0	282	0	24
bare soil	184	03/07/04	113	23/04/05		379	2479	41	323	1	25
Sunflower	114	24/04/05	260	17/09/05	1245	350	2829	31	354	2	27

days	Rainfall	Drainage	Nitrate Leaching
	mm/day	mm/day	g N/day
294	1,11	0,49	57,8
146	2,40	0,22	27,4
25	1,24	-	-
261	1,51	-	-
304	0,99	0,18	6,6
136	2,03	0,37	7,4
25	1,28	-	-
262	1,50	-	-
294	1,29	0,14	3,4
146	2,40	0,21	13,7

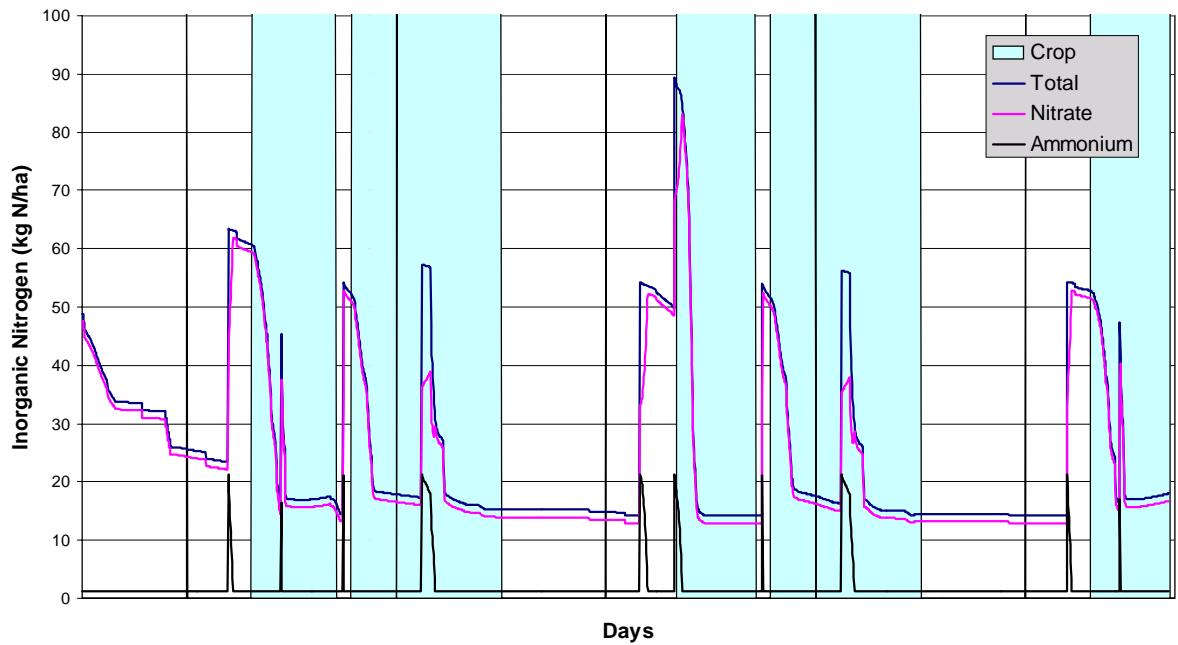
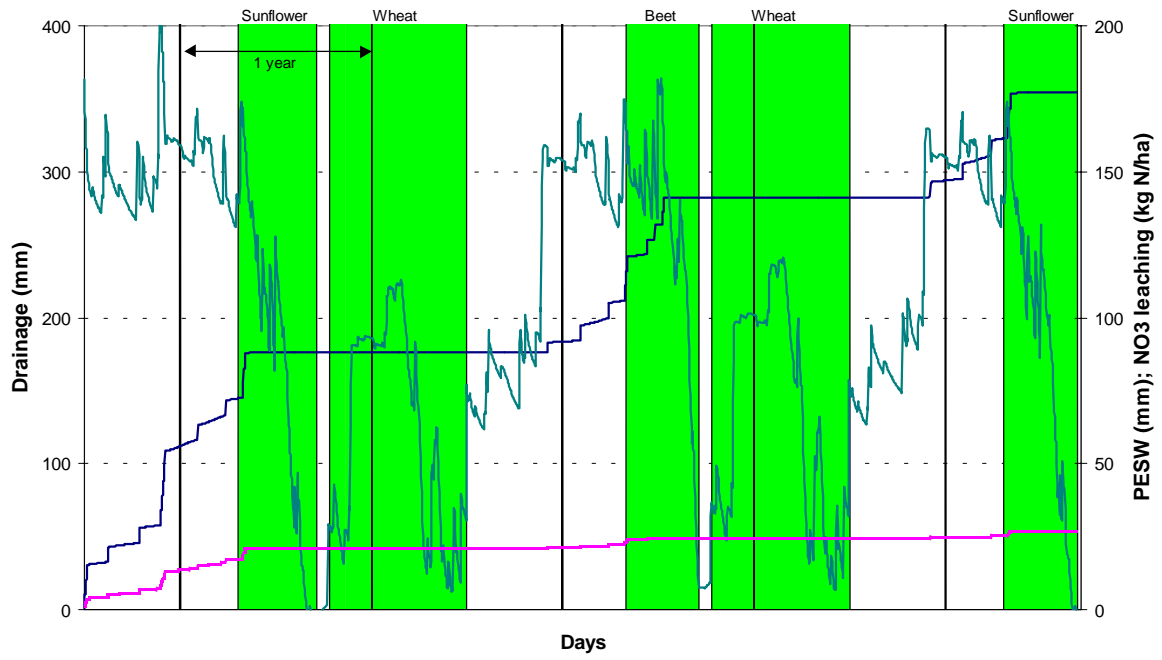

n° 13 – Sunflower Wheat 2x Maize 2x

Soil : Chelopechene

Meteo: Pleven

Year: 1966 - rainy

CROP	from		to		Yield (DM) g/m ²	Rainfall		Drainage		NO3 leaching	
						period	cumul	period	cumul	period	cumul
						mm		mm		kg N/ha	
bare soil	221	09/08/00	114	24/04/01		470	470	196	196	49	49
Sunflower	115	25/04/01	233	21/08/01	1431	288	758	1	197	0	49
bare soil	234	22/08/01	286	13/10/01		66	824	0	197	0	49
Wheat	287	14/10/01	164	13/06/02	872	452	1276	62	259	7	56
bare soil	165	14/06/02	286	13/10/02		306	1582	18	277	0	56
Wheat	287	14/10/02	164	13/06/03	636	452	2034	134	411	0	56
bare soil	165	14/06/03	115	25/04/04		710	2744	217	628	1	57
Maize	116	26/04/04	231	19/08/04	569	288	3032	1	629	0	57
bare soil	232	20/08/04	115	25/04/05		461	3493	124	753	2	59
Maize	116	26/04/05	231	19/08/05	442	288	3781	1	754	0	59
bare soil	232	20/08/05	113	23/04/06		461	4242	124	878	1	60
Sunflower	114	24/04/06	233	21/08/06	523	288	4530	2	880	0	60

days	Rainfall	Drainage	Nitrate Leaching
	mm/day	mm/day	g N/day
258	1,82	0,76	189,9
118	2,44	0,01	-
52	1,27	-	-
242	1,87	0,26	28,9
121	2,53	0,15	-
242	1,87	0,55	-
316	2,25	0,69	3,2
115	2,50	0,01	-
248	1,86	0,50	8,1
115	2,50	0,01	-
246	1,87	0,50	4,1
119	2,42	0,02	-

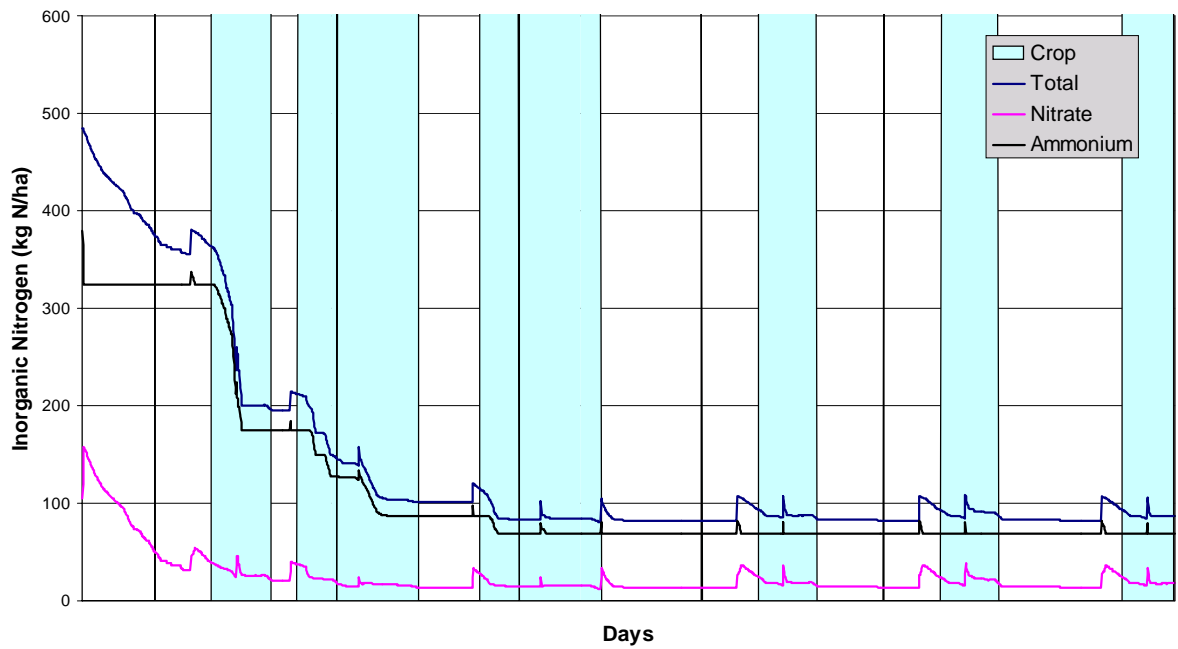
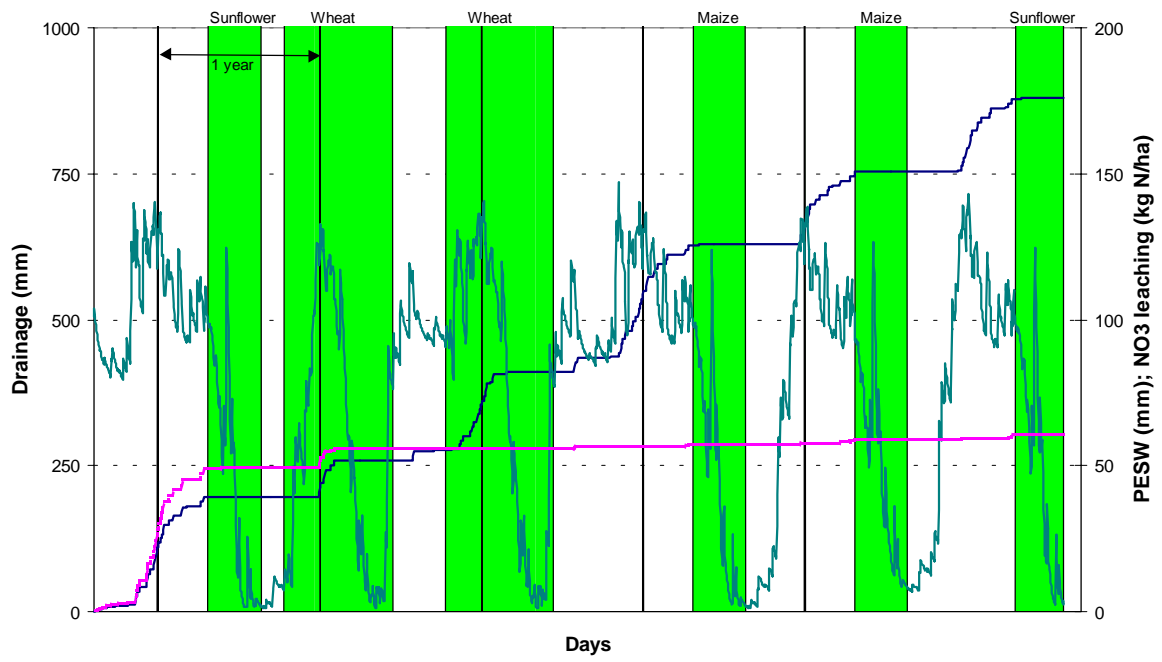

n° 14 – Sunflower Wheat 2x Maize 2x

Soil : Chelopechene
Meteo: Pleven
Year: 1971 - average

CROP	from		to		Yield (DM) g/m ²	Rainfall		Drainage		NO3 leaching	
						period	cumul	period	cumul	period	cumul
						mm		mm		kg N/ha	
bare soil	221	09/08/00	114	24/04/01		359	359	138	138	35	35
Sunflower	115	25/04/01	233	21/08/01	1196	257	616	10	148	3	38
bare soil	234	22/08/01	286	13/10/01		81	697	0	148	0	38
Wheat	287	14/10/01	164	13/06/02	916	327	1024	23	171	5	43
bare soil	165	14/06/02	286	13/10/02		275	1299	24	195	3	46
Wheat	287	14/10/02	164	13/06/03	602	326	1625	85	280	2	48
bare soil	165	14/06/03	115	25/04/04		548	2173	137	417	0	48
Maize	116	26/04/04	231	19/08/04	582	252	2425	9	426	0	48
bare soil	232	20/08/04	115	25/04/05		354	2779	54	480	1	49
Maize	116	26/04/05	231	19/08/05	487	252	3031	10	490	0	49
bare soil	232	20/08/05	113	23/04/06		349	3380	54	544	0	49
Sunflower	114	24/04/06	233	21/08/06	412	256	3636	10	554	1	50

days	Rainfall	Drainage	Nitrate Leaching
	mm/day	mm/day	g N/day
258	1,39	0,53	135,7
118	2,18	0,08	25,4
52	1,56	-	-
242	1,35	0,10	20,7
121	2,27	0,20	24,8
242	1,35	0,35	8,3
316	1,73	0,43	-
115	2,19	0,08	-
248	1,43	0,22	4,0
115	2,19	0,09	-
246	1,42	0,22	-
119	2,15	0,08	8,4

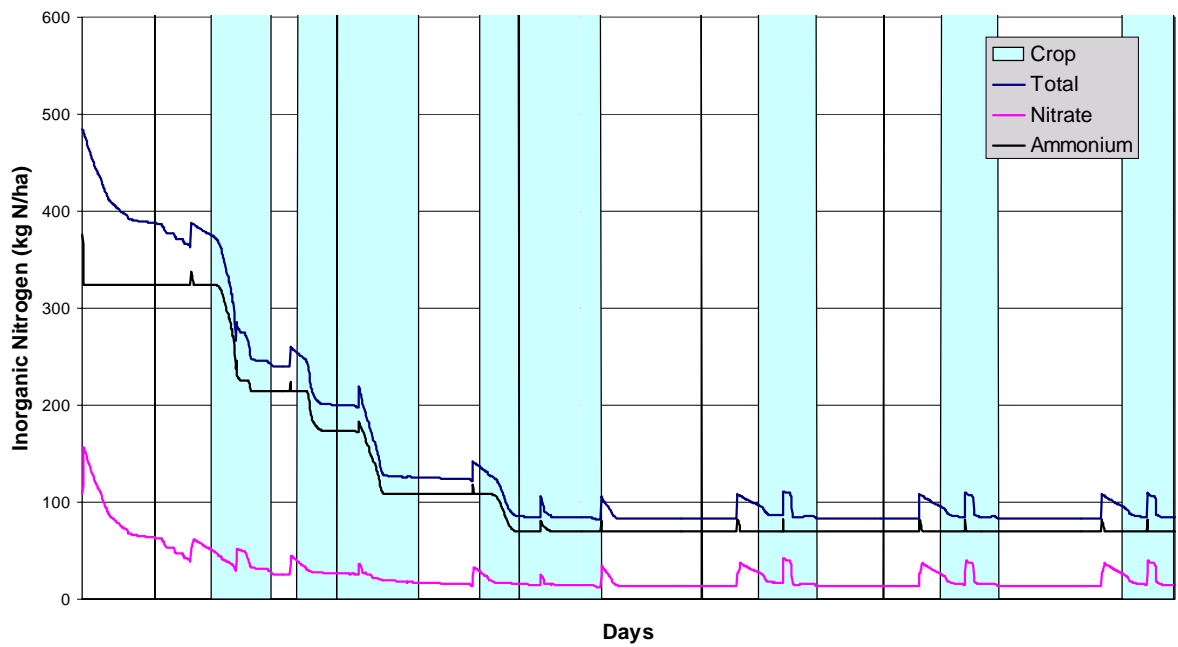
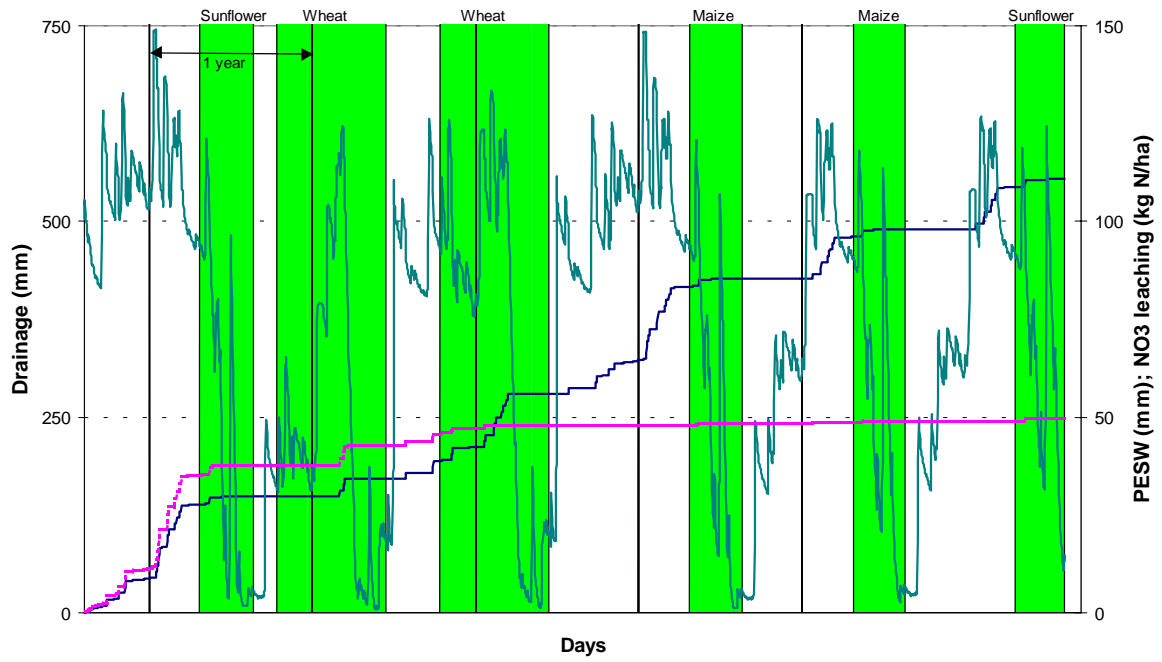

n° 15 – Sunflower Wheat 2x Maize 2x

Soil : Chelopechene

Meteo: Obrastzov

Year: 1969 - rainy

CROP	from		to		Yield (DM) g/m ²	Rainfall		Drainage		NO3 leaching	
	day	date	day	date		period	cumul	period	cumul	period	cumul
						mm		mm		kg N/ha	
bare soil	221	09/08/00	114	24/04/01		477	477	308	308	70	70
Sunflower	115	25/04/01	233	21/08/01	1600	383	860	1	309	0	70
bare soil	234	22/08/01	286	13/10/01		28	888	0	309	0	70
Wheat	287	14/10/01	164	13/06/02	468	537	1425	242	551	8	78
bare soil	165	14/06/02	286	13/10/02		311	1736	84	635	0	78
Wheat	287	14/10/02	164	13/06/03	745	536	2272	265	900	2	80
bare soil	165	14/06/03	115	25/04/04		758	3030	388	1288	5	85
Maize	116	26/04/04	231	19/08/04	812	373	3403	10	1298	1	86
bare soil	232	20/08/04	115	25/04/05		474	3877	226	1524	1	87
Maize	116	26/04/05	231	19/08/05	738	374	4251	10	1534	1	88
bare soil	232	20/08/05	113	23/04/06		451	4702	234	1768	2	90
Sunflower	114	24/04/06	233	21/08/06	690	397	5099	2	1770	0	90

days	Rainfall	Drainage	Nitrate Leaching
	mm/day	mm/day	g N/day
258	1,85	1,19	271,3
118	3,25	0,01	-
52	0,54	-	-
242	2,22	1,00	33,1
121	2,57	0,69	-
242	2,21	1,10	8,3
316	2,40	1,23	15,8
115	3,24	0,09	8,7
248	1,91	0,91	4,0
115	3,25	0,09	8,7
246	1,83	0,95	8,1
119	3,34	0,02	-

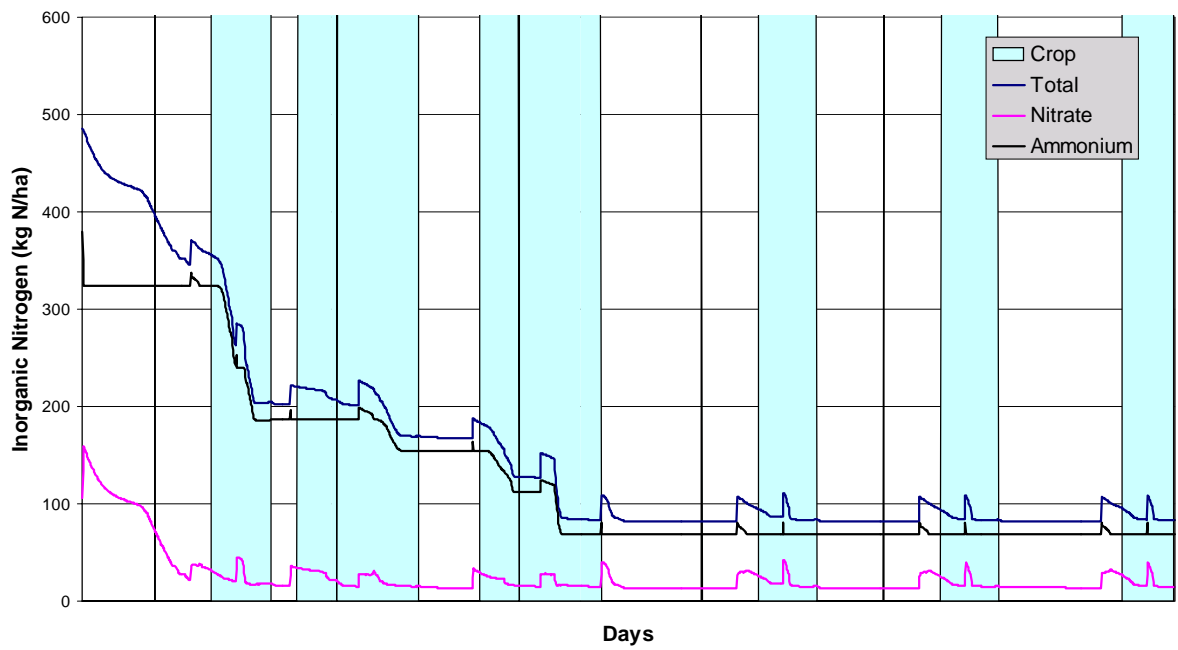
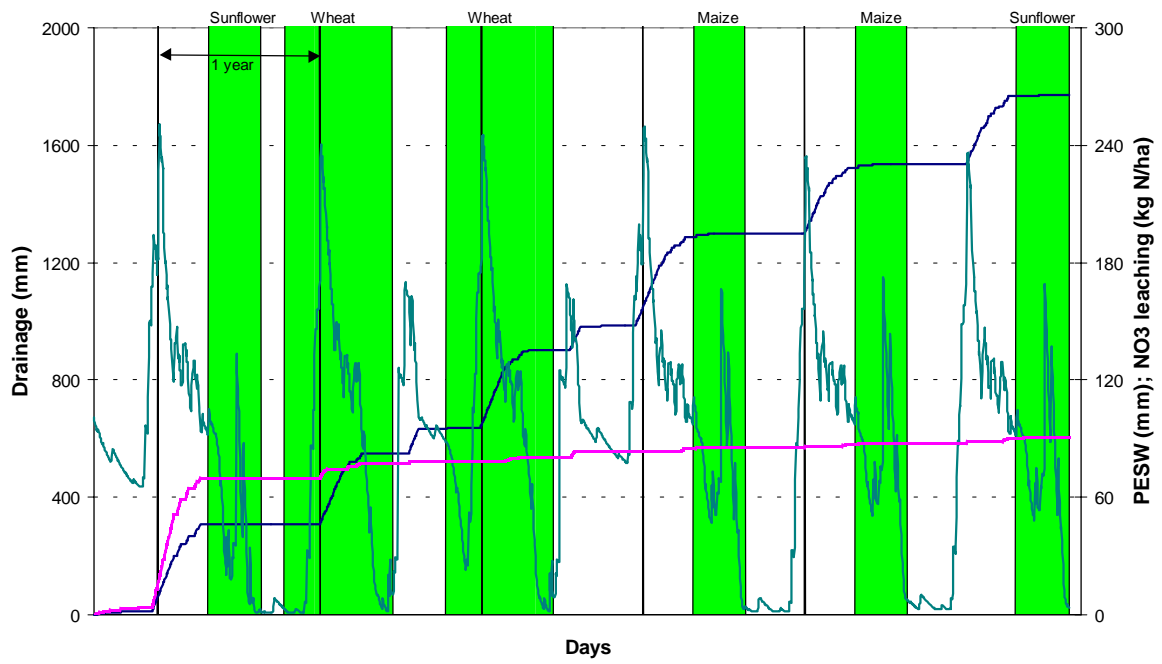

n° 16 – Sunflower Wheat 2x Maize 2x

Soil : Chelopechene
Meteo: Obrastzov
Year: 1976 - average

CROP	from		to		Yield (DM) g/m ²	Rainfall		Drainage		NO3 leaching	
						period	cumul	period	cumul	period	cumul
						mm		mm		kg N/ha	
bare soil	221	09/08/00	114	24/04/01		346	346	93	93	24	24
Sunflower	115	25/04/01	233	21/08/01	942	297	643	39	132	9	33
bare soil	234	22/08/01	286	13/10/01		42	685	0	132	0	33
Wheat	287	14/10/01	164	13/06/02	946	379	1064	0	132	0	33
bare soil	165	14/06/02	286	13/10/02		233	1297	0	132	0	33
Wheat	287	14/10/02	164	13/06/03	1120	368	1665	18	150	3	36
bare soil	165	14/06/03	115	25/04/04		515	2180	46	196	5	41
Maize	116	26/04/04	231	19/08/04	373	298	2478	47	243	1	42
bare soil	232	20/08/04	115	25/04/05		314	2792	15	258	1	43
Maize	116	26/04/05	231	19/08/05	280	297	3089	47	305	3	46
bare soil	232	20/08/05	113	23/04/06		307	3396	34	339	0	46
Sunflower	114	24/04/06	233	21/08/06	283	305	3701	55	394	4	50

days	Rainfall	Drainage	Nitrate Leaching
	mm/day	mm/day	g N/day
258	1,34	0,36	93,0
118	2,52	0,33	76,3
52	0,81	-	-
242	1,57	-	-
121	1,93	-	-
242	1,52	0,07	12,4
316	1,63	0,15	15,8
115	2,59	0,41	8,7
248	1,27	0,06	4,0
115	2,58	0,41	26,1
246	1,25	0,14	-
119	2,56	0,46	33,6

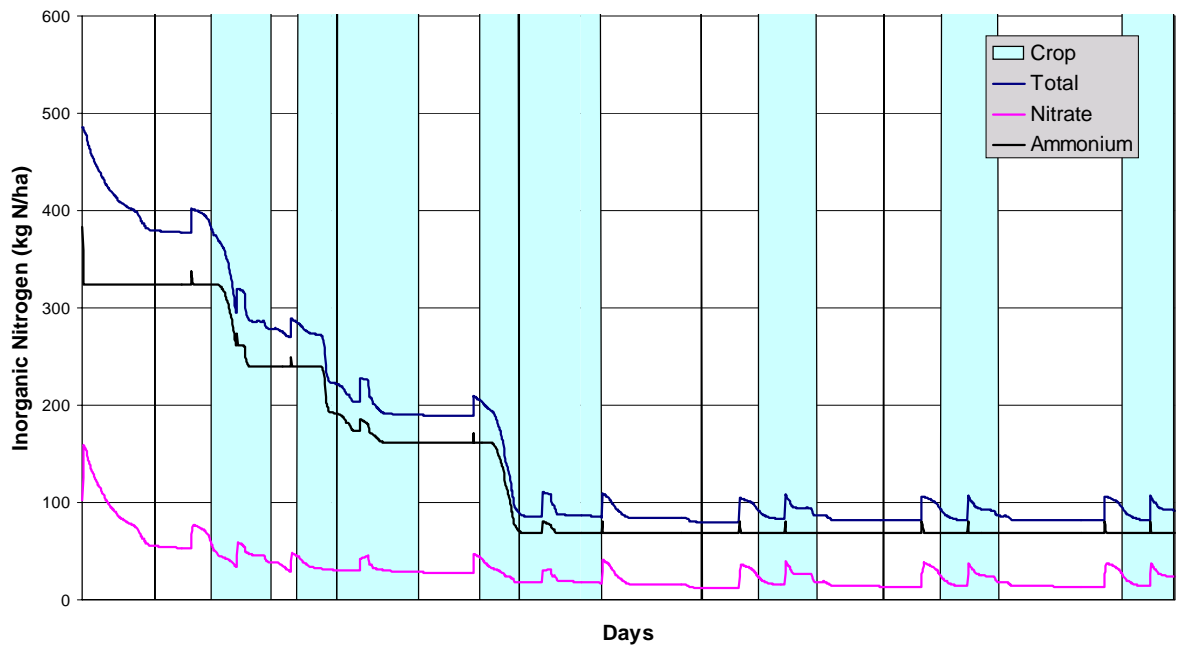
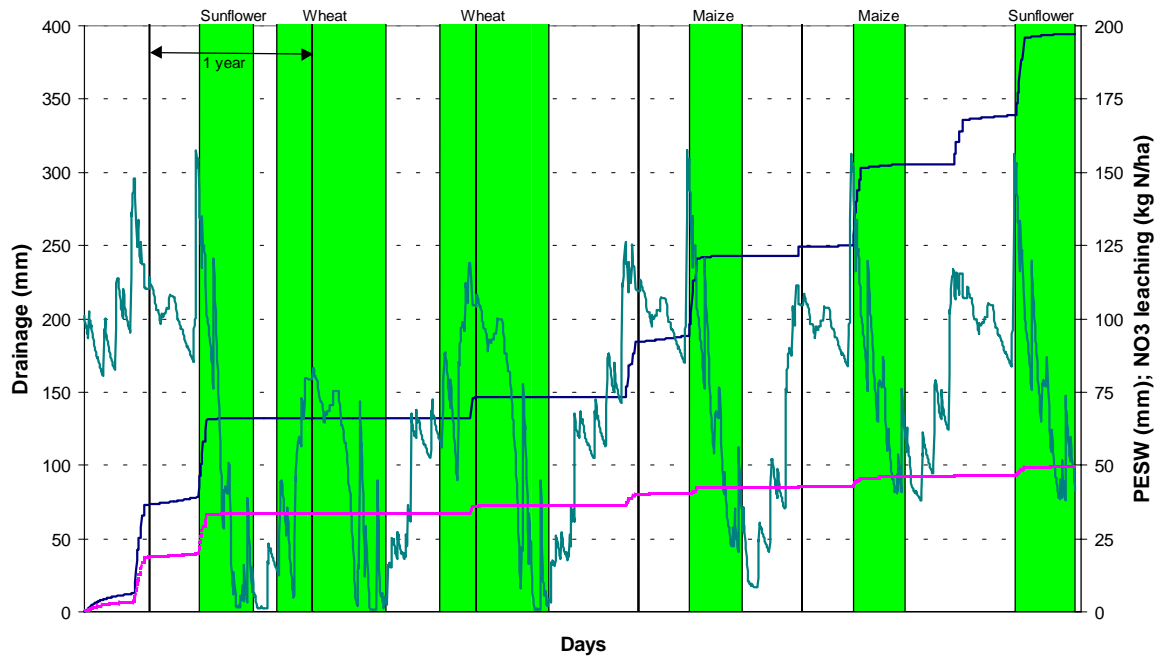

n° 17 – Sunflower Wheat 2x Maize 2x

Soil : Bojurishte
Meteo: Pleven
Year: 1966 - rainy

CROP	from		to		Yield (DM) g/m ²	Rainfall		Drainage		NO3 leaching	
						period	cumul	period	cumul	period	cumul
						mm		mm		kg N/ha	
bare soil	221	09/08/00	114	24/04/01		470	470	152	152	18	18
Sunflower	115	25/04/01	233	21/08/01	1809	288	758	33	185	4	22
bare soil	234	22/08/01	286	13/10/01		66	824	0	185	0	22
Wheat	287	14/10/01	164	13/06/02	1168	584	1408	0	185	0	22
bare soil	165	14/06/02	286	13/10/02		173	1581	0	185	0	22
Wheat	287	14/10/02	164	13/06/03	1603	584	2165	0	185	0	22
bare soil	165	14/06/03	115	25/04/04		579	2744	0	185	0	22
Maize	116	26/04/04	231	19/08/04	1879	287	3031	9	194	1	23
bare soil	232	20/08/04	115	25/04/05		462	3493	0	194	0	23
Maize	116	26/04/05	231	19/08/05	1598	288	3781	0	194	0	23
bare soil	232	20/08/05	113	23/04/06		460	4241	0	194	0	23
Sunflower	114	24/04/06	233	21/08/06	1600	289	4530	0	194	0	23

days	Rainfall	Drainage	Nitrate Leaching
	mm/day	mm/day	g N/day
258	1,82	0,59	69,8
118	2,44	0,28	33,9
52	1,27	-	-
242	2,41	-	-
121	1,43	-	-
242	2,41	-	-
316	1,83	-	-
115	2,50	0,08	8,7
248	1,86	-	-
115	2,50	-	-
246	1,87	-	-
119	2,43	-	-

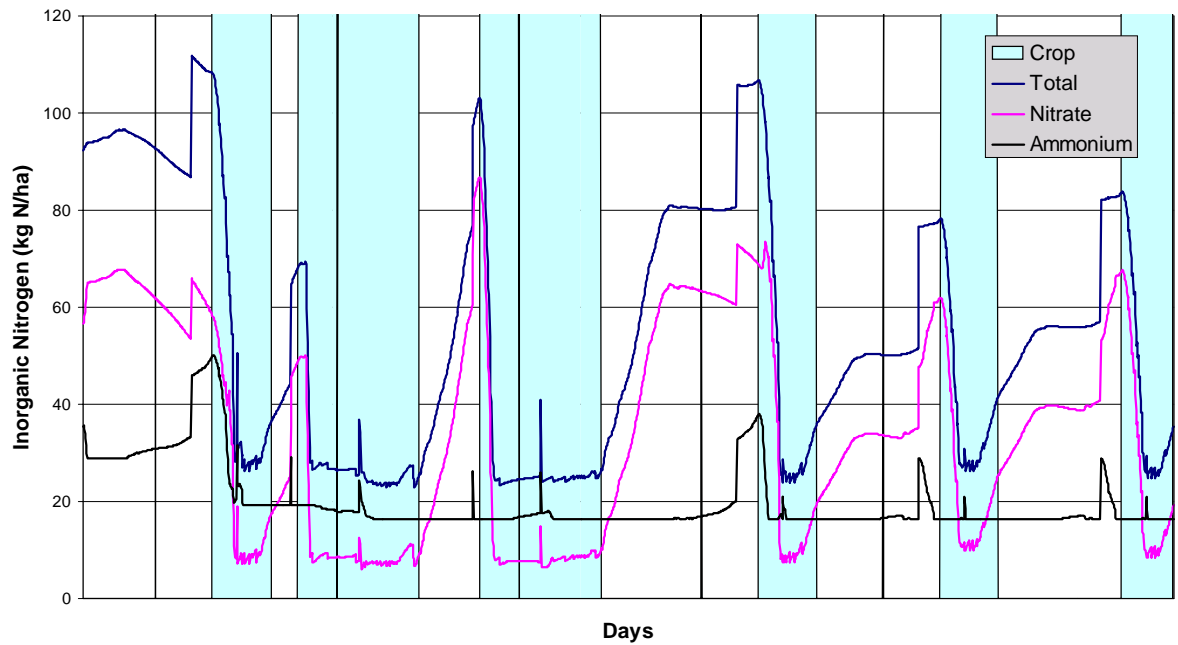
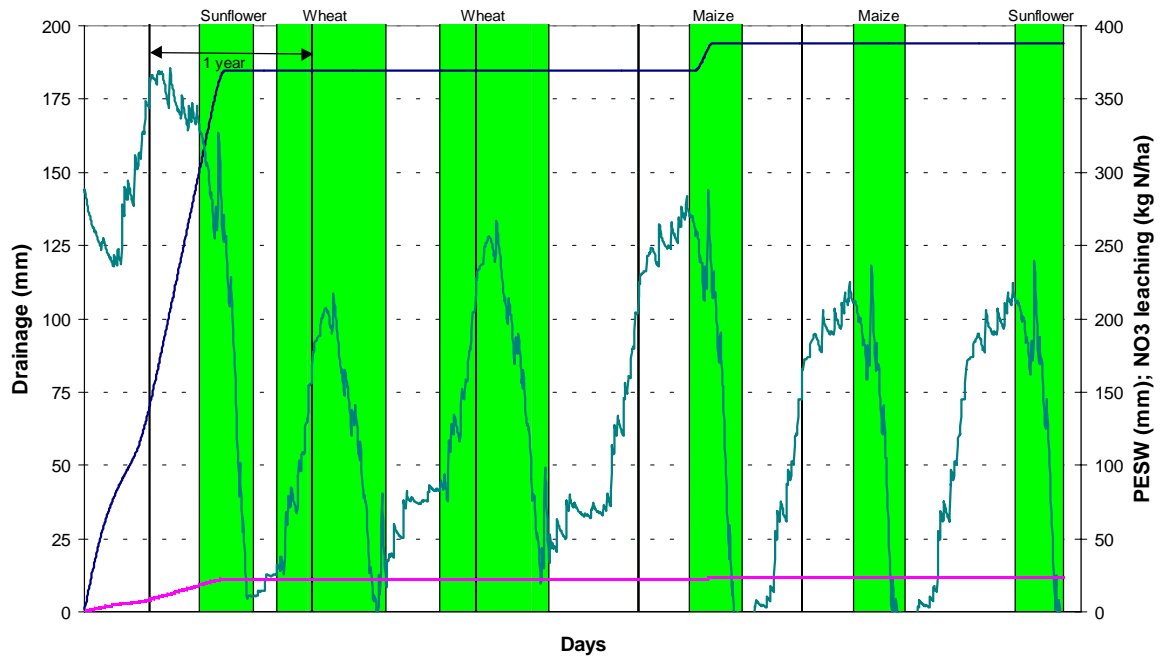

n° 18 – Sunflower Wheat 2x Maize 2x

Soil : Bojurishte
Meteo: Pleven
Year: 1971 - average

CROP	from		to		Yield (DM) g/m ²	Rainfall		Drainage		NO3 leaching	
						period	cumul	period	cumul	period	cumul
						mm		mm		kg N/ha	
bare soil	221	09/08/00	114	24/04/01		359	359	155	155	19	19
Sunflower	115	25/04/01	233	21/08/01	1709	257	616	24	179	3	22
bare soil	234	22/08/01	286	13/10/01		81	697	0	179	0	22
Wheat	287	14/10/01	164	13/06/02	844	374	1071	0	179	0	22
bare soil	165	14/06/02	286	13/10/02		217	1288	0	179	0	22
Wheat	287	14/10/02	164	13/06/03	1024	374	1662	0	179	0	22
bare soil	165	14/06/03	115	25/04/04		490	2152	0	179	0	22
Maize	116	26/04/04	231	19/08/04	1673	252	2404	0	179	0	22
bare soil	232	20/08/04	115	25/04/05		354	2758	0	179	0	22
Maize	116	26/04/05	231	19/08/05	1491	252	3010	0	179	0	22
bare soil	232	20/08/05	113	23/04/06		349	3359	0	179	0	22
Sunflower	114	24/04/06	233	21/08/06	1501	256	3615	0	179	0	22

days	Rainfall	Drainage	Nitrate Leaching
	mm/day	mm/day	g N/day
258	1,39	0,60	73,6
118	2,18	0,20	25,4
52	1,56	-	-
242	1,55	-	-
121	1,79	-	-
242	1,55	-	-
316	1,55	-	-
115	2,19	-	-
248	1,43	-	-
115	2,19	-	-
246	1,42	-	-
119	2,15	-	-

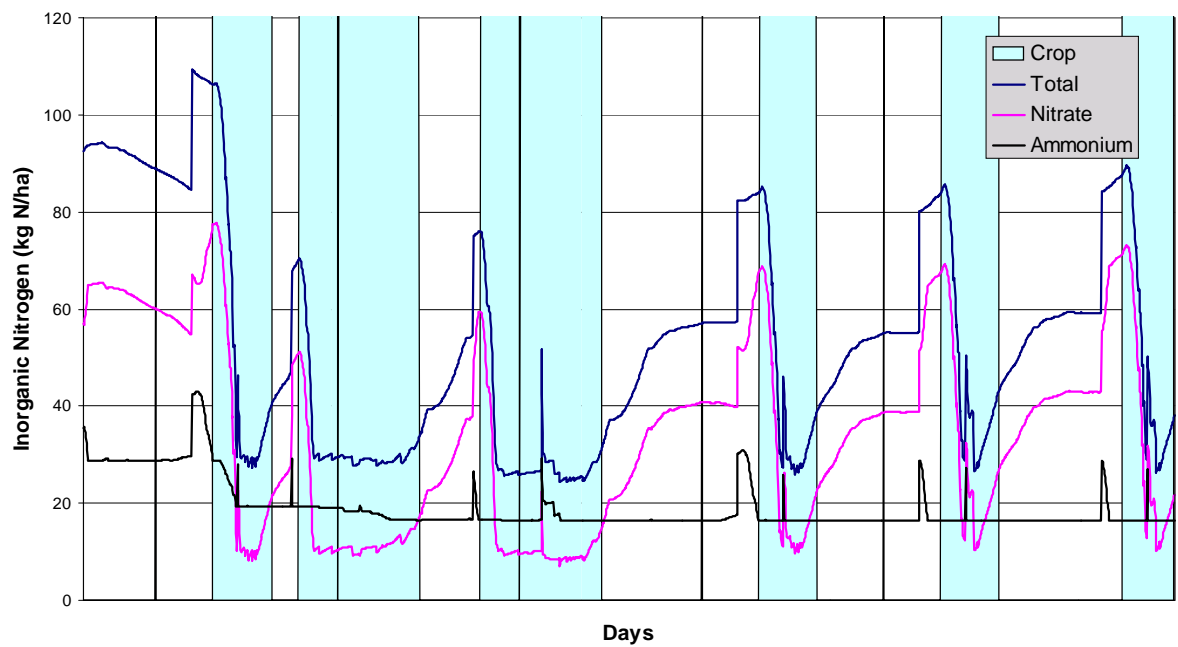
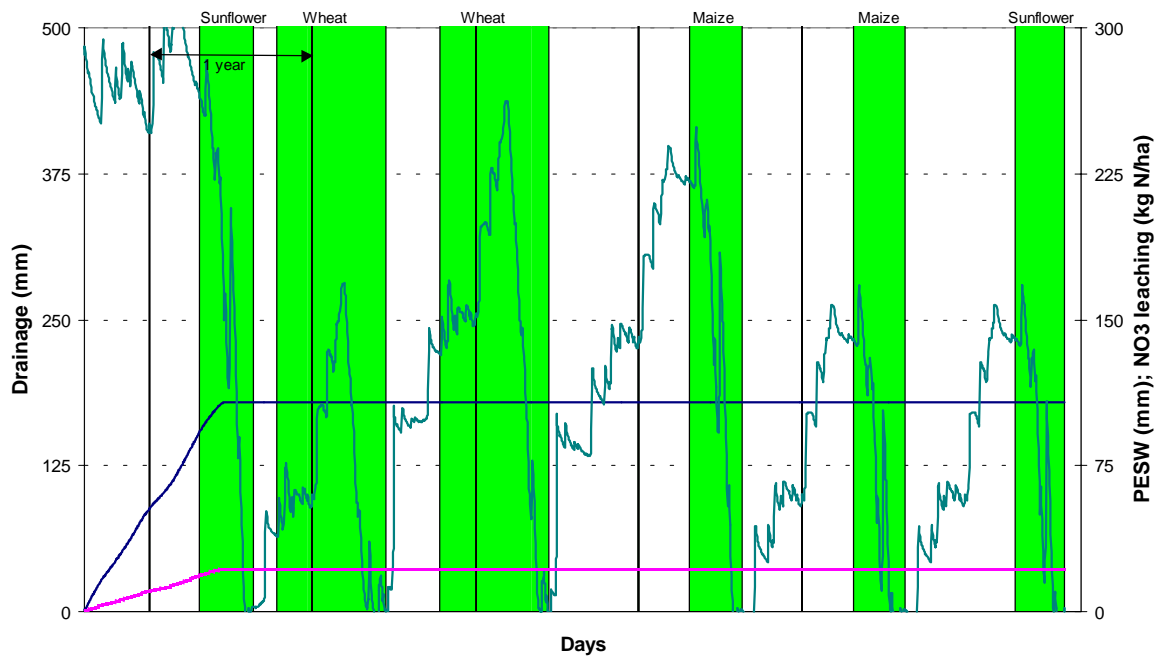

n° 19 – Sunflower Wheat 2x Maize 2x

Soil : Bojurishte
Meteo: Obrastzov
Year: 1969 - rainy

CROP	from		to		Yield (DM) g/m ²	Rainfall		Drainage		NO3 leaching	
	day	date	day	date		period	cumul	period	cumul	period	cumul
						mm		mm		kg N/ha	
bare soil	221	09/08/00	114	24/04/01		477	477	125	125	15	15
Sunflower	115	25/04/01	233	21/08/01	1881	383	860	34	159	4	19
bare soil	234	22/08/01	286	13/10/01		28	888	0	159	0	19
Wheat	287	14/10/01	164	13/06/02	664	537	1425	29	188	0	19
bare soil	165	14/06/02	286	13/10/02		311	1736	71	259	0	19
Wheat	287	14/10/02	164	13/06/03	698	536	2272	136	395	0	19
bare soil	165	14/06/03	115	25/04/04		758	3030	213	608	1	20
Maize	116	26/04/04	231	19/08/04	1825	373	3403	37	645	1	21
bare soil	232	20/08/04	115	25/04/05		474	3877	69	714	1	22
Maize	116	26/04/05	231	19/08/05	1549	374	4251	37	751	0	22
bare soil	232	20/08/05	113	23/04/06		451	4702	70	821	1	23
Sunflower	114	24/04/06	233	21/08/06	1540	397	5099	39	860	0	23

days	Rainfall	Drainage	Nitrate Leaching
	mm/day	mm/day	g N/day
258	1,85	0,48	58,1
118	3,25	0,29	33,9
52	0,54	-	-
242	2,22	0,12	-
121	2,57	0,59	-
242	2,21	0,56	-
316	2,40	0,67	3,2
115	3,24	0,32	8,7
248	1,91	0,28	4,0
115	3,25	0,32	-
246	1,83	0,28	4,1
119	3,34	0,33	-

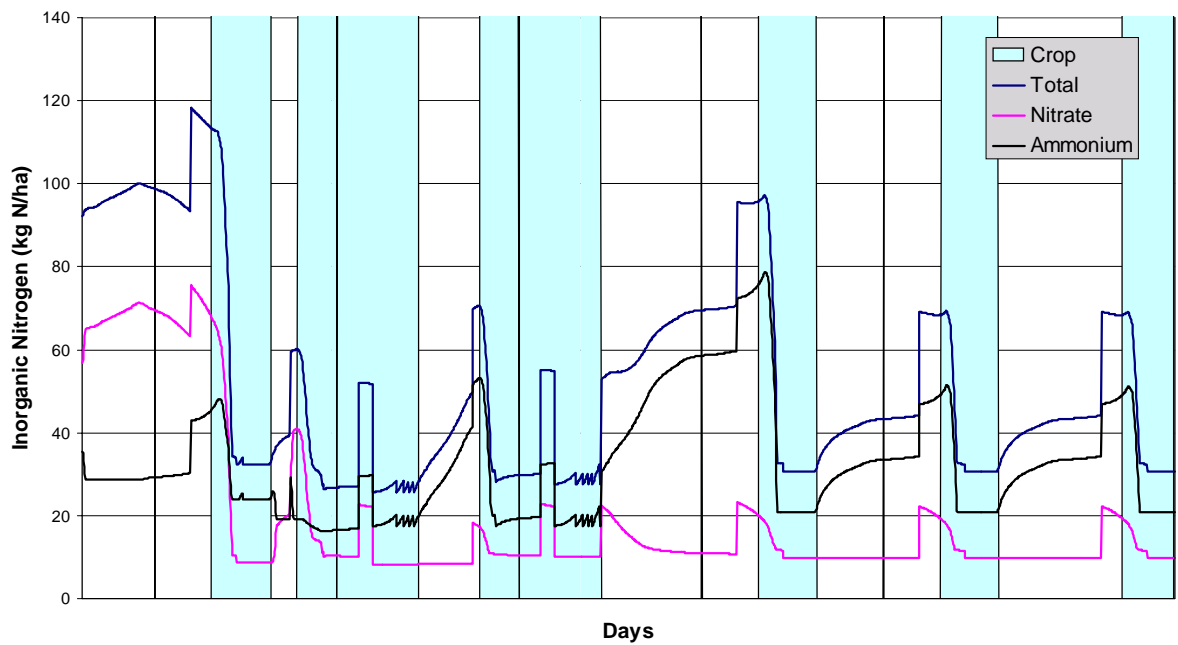
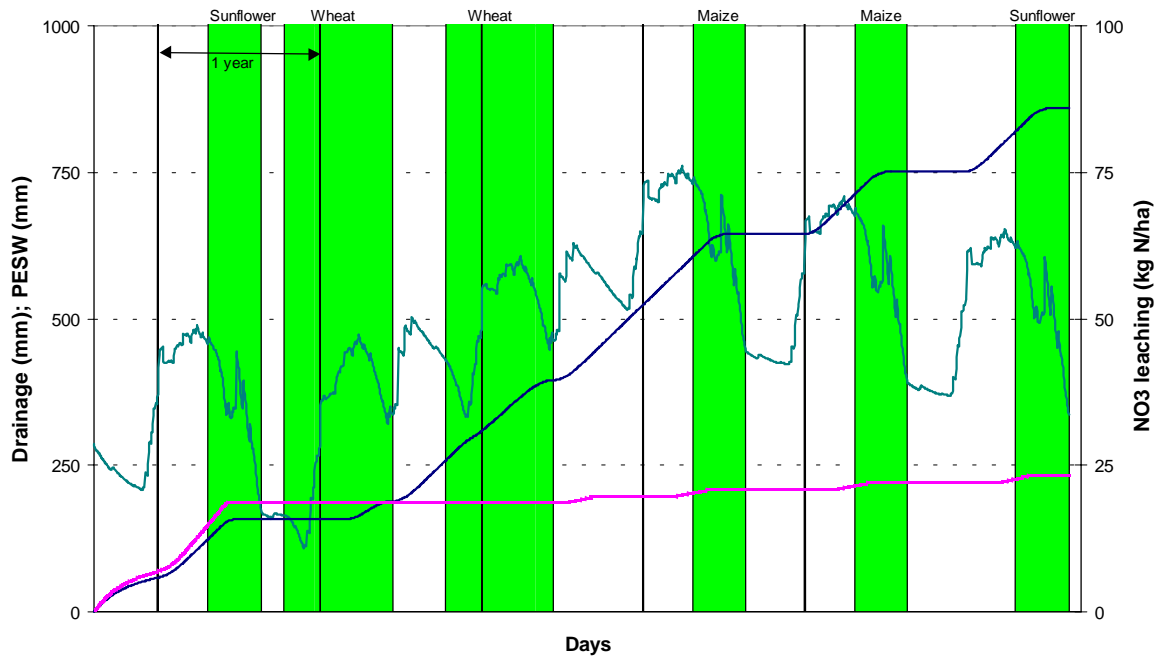

n° 20 – Sunflower Wheat 2x Maize 2x

Soil : Bojurishte
Meteo: Obrastzov
Year: 1976 – average

CROP	from		to		Yield (DM) g/m ²	Rainfall		Drainage		NO3 leaching	
	day	date	day	date		period	cumul	period	cumul	period	cumul
						mm		mm		kg N/ha	
bare soil	221	09/08/00	114	24/04/01		346	346	127	127	15	15
Sunflower	115	25/04/01	233	21/08/01	1626	297	643	24	151	3	18
bare soil	234	22/08/01	286	13/10/01		42	685	0	151	0	18
Wheat	287	14/10/01	164	13/06/02	831	379	1064	0	151	0	18
bare soil	165	14/06/02	286	13/10/02		233	1297	0	151	0	18
Wheat	287	14/10/02	164	13/06/03	1187	371	1668	0	151	0	18
bare soil	165	14/06/03	115	25/04/04		507	2175	0	151	0	18
Maize	116	26/04/04	231	19/08/04	1586	297	2472	0	151	0	18
bare soil	232	20/08/04	115	25/04/05		315	2787	0	151	0	18
Maize	116	26/04/05	231	19/08/05	1230	297	3084	0	151	0	18
bare soil	232	20/08/05	113	23/04/06		307	3391	0	151	0	18
Sunflower	114	24/04/06	233	21/08/06	1194	305	3696	0	151	0	18

days	Rainfall	Drainage	Nitrate Leaching
	mm/day	mm/day	g N/day
258	1,34	0,49	58,1
118	2,52	0,20	25,4
52	0,81	-	-
242	1,57	-	-
121	1,93	-	-
242	1,53	-	-
316	1,60	-	-
115	2,58	-	-
248	1,27	-	-
115	2,58	-	-
246	1,25	-	-
119	2,56	-	-

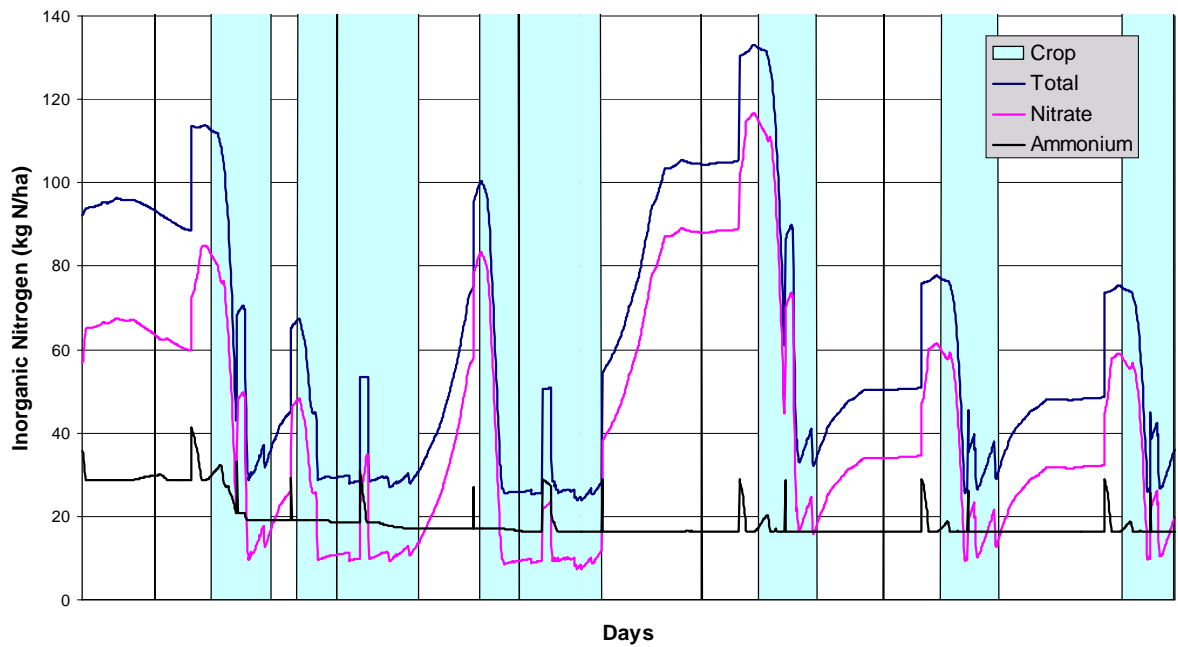
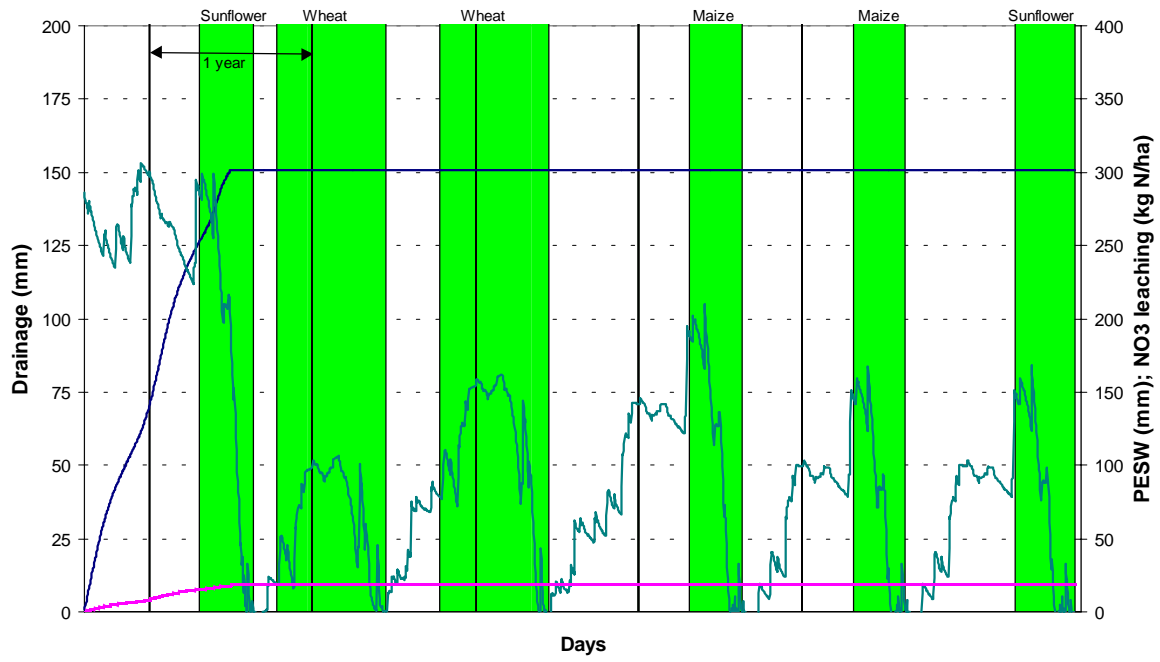

n° 21 – Wheat Rapeseed Maize

Soil : Bojurishte
Meteo: Pleven
Year: 1966 - rainy

CROP	from		to		Yield (DM) g/m ²	Rainfall		Drainage		NO3 leaching	
						period	cumul	period	cumul	period	cumul
						mm		mm		kg N/ha	
bare soil	170	19/06/00	286	13/10/00		232	232	0		0	
Wheat	287	14/10/00	169	18/06/01	1024	374	606	0		0	
bare soil	170	19/06/01	268	25/09/01		152	758	0		0	
RapeSeed	269	26/09/01	80	21/03/02	1756	357	1115	0		0	
bare soil	81	22/03/02	104	14/04/02		45	1160	0		0	
Maize	105	15/04/02	220	08/08/02	905	312	1472	0		0	

days	Rainfall	Drainage	Nitrate Leaching
	mm/day	mm/day	g N/day
116	2,00	-	-
247	1,51	-	-
98	1,55	-	-
176	2,03	-	-
23	1,96	-	-
115	2,71	-	-

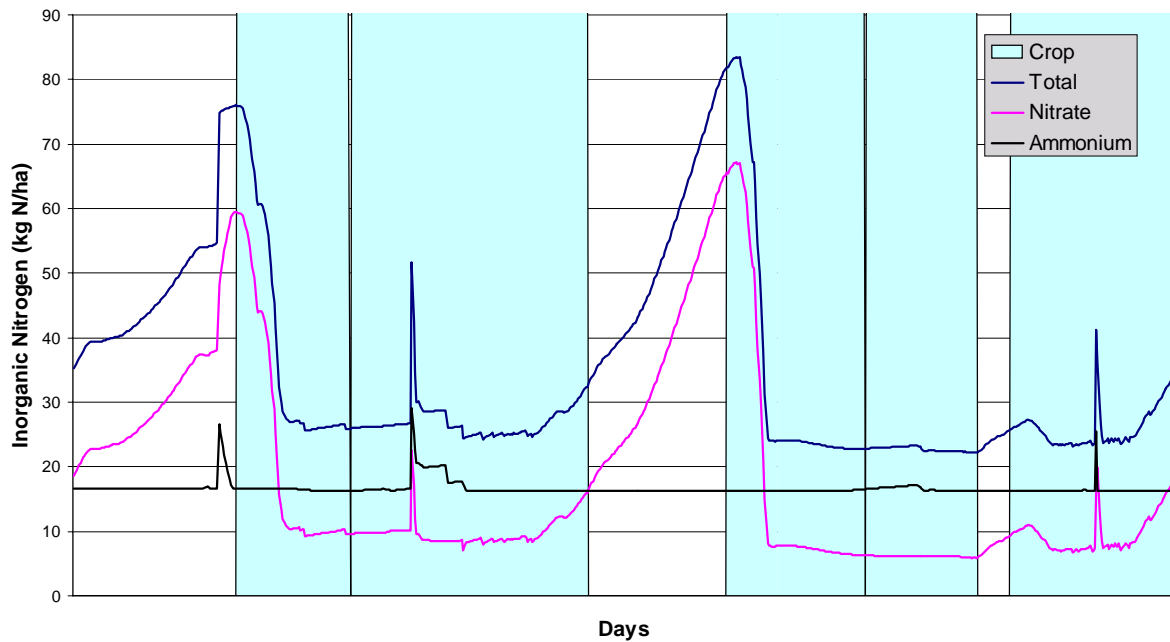
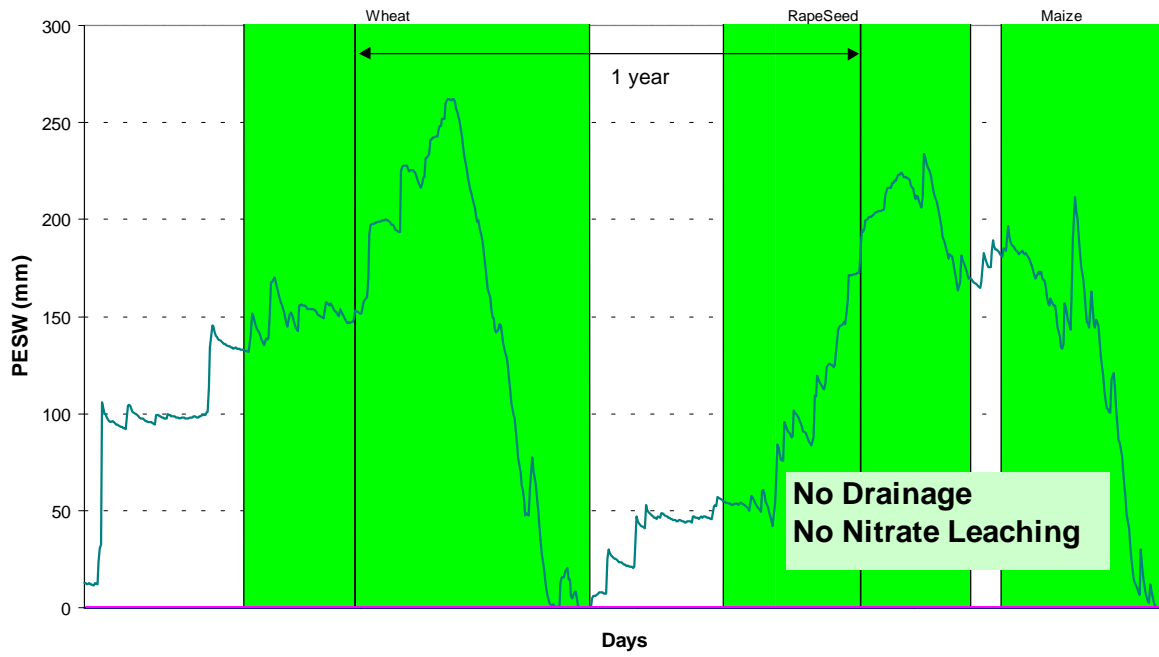

n° 22 – Wheat Rapeseed Maize

Soil : Bojurishte
Meteo: Pleven
Year: 1967 - dry

CROP	from		to		Yield (DM) g/m ²	Rainfall		Drainage		NO3 leaching	
						period	cumul	period	cumul	period	cumul
						mm		mm		kg N/ha	
bare soil	170	19/06/00	286	13/10/00		232	232	0		0	
Wheat	287	14/10/00	169	18/06/01	1024	374	606	0		0	
bare soil	170	19/06/01	268	25/09/01		93	699	0		0	
RapeSeed	269	26/09/01	80	21/03/02	1424	133	832	0		0	
bare soil	81	22/03/02	104	14/04/02		8	840	0		0	
Maize	105	15/04/02	120	30/04/02	0	40	880	0		0	

days	Rainfall	Drainage	Nitrate Leaching
	mm/day	mm/day	g N/day
116	2,00	-	-
247	1,51	-	-
98	0,95	-	-
176	0,76	-	-
23	0,35	-	-
15	2,67	-	-

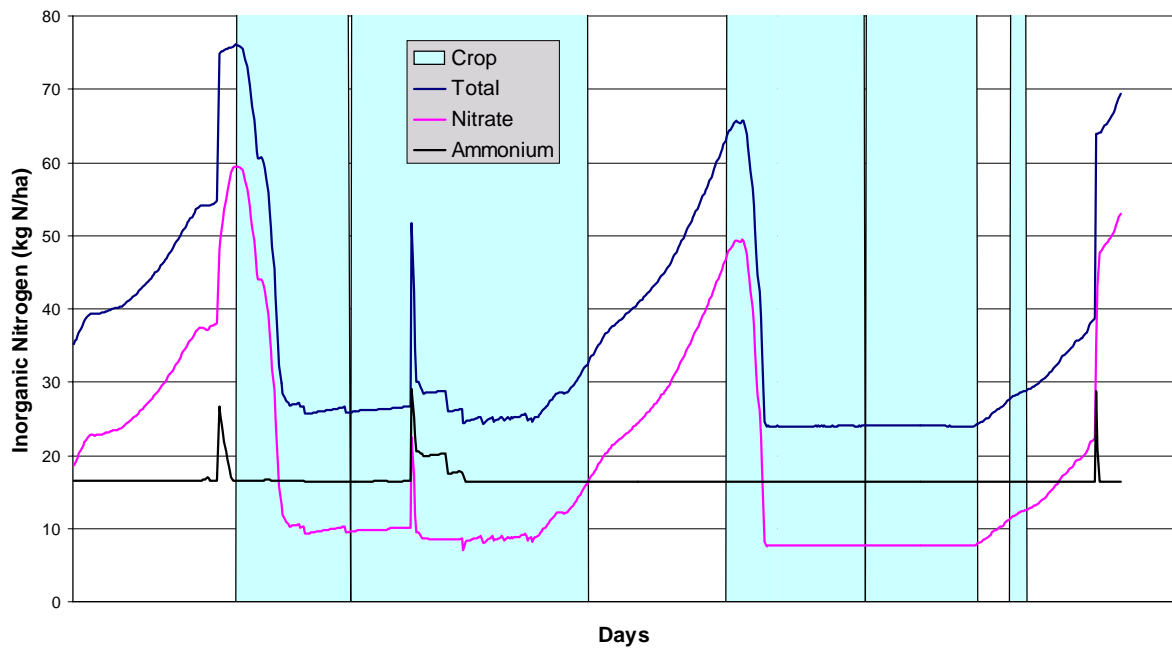
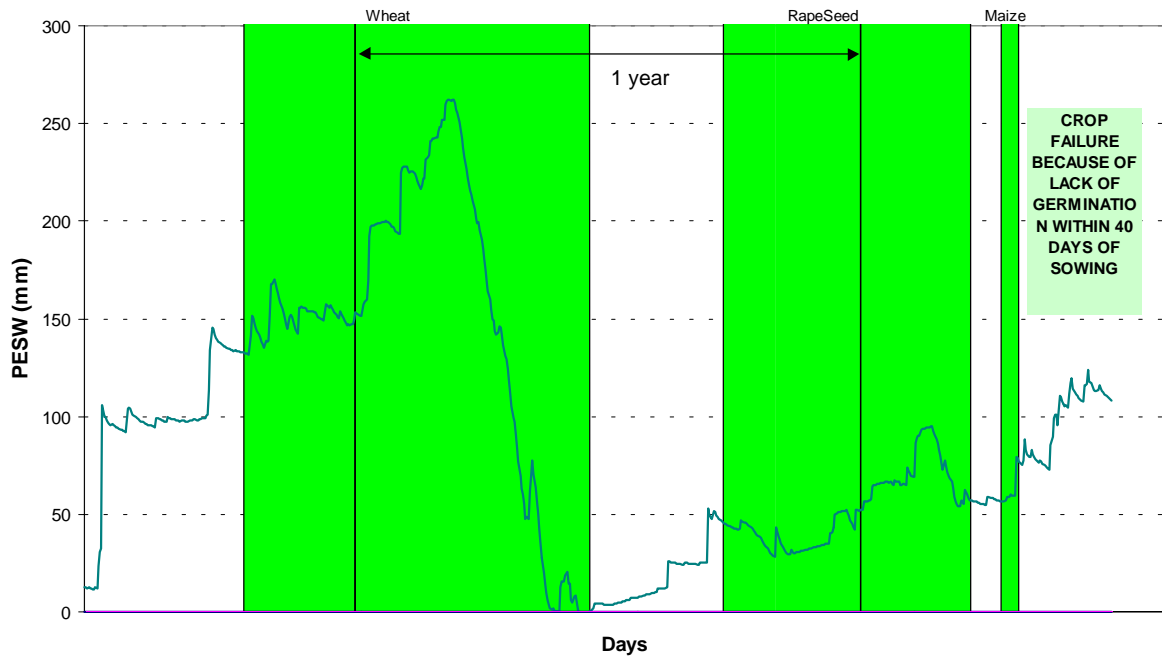

APPENDIX H

Pollution of the Black Sea

1.	SUSTAINABLE DEVELOPMENT IN THE MEDITERRANEAN AND BLACK SEA BASINS. .	267
2.	THE NATO COMMITTEE ON THE CHALLENGES OF MODERN SOCIETY.	286
3.	THE BLACK SEA “EUTROPHICATION SYNDROME”	290
4.	BETTER DAYS FOR THE BLACK SEA.	291
5.	REGIONAL AND GLOBAL ECOLOGICAL PROBLEMS.	292
6.	L'ENVIRONNEMENT EN EUROPE: EXTRAIT DE LA DEUXIEME EVALUATION.....	296
7.	PUBLICATIONS.....	297

10. Sustainable development in the Mediterranean and Black Sea basins.

<http://www.seafront.org/archive/recoder-report7977.htm>

8 January 1998.

Committee on the Environment, Regional Planning and Local Authorities.

Rapporteur : Mr Lluís Recoder, Spain, Liberal, Democratic and Reformers' Group.

Summary.

In many respects, particularly as regards the environment, the Black Sea and the Mediterranean form a single basin. Therefore, problems affecting this area would be better tackled if approached from an overall perspective. The Council of Europe can help. On the one hand it has always paid much attention to Mediterranean affairs. On the other hand, all of the Black Sea rim countries have now either joined the Organisation or been granted special guest status. The Assembly thus proposes that parliamentary co-operation in this field be strengthened by setting up a dialogue with parliaments from Mediterranean countries which do not belong to the Council of Europe. This process could be further improved by bringing into it local and regional authorities from that area.

I. Draft resolution.

1. The Parliamentary Assembly has long given attention to the problems of co-operation and sustainable development in the Mediterranean, particularly through the conferences of Mediterranean regions held in co-operation with the Congress of Local and Regional Authorities of Europe, the most recent of which, the fourth, took place in Cyprus in October 1995.
2. It is gratifying to note that, through the Euro-Mediterranean Conference, held in Barcelona in November 1995, the European Union decided to intensify co-operation in the Mediterranean area and initiated a very large-scale partnership with those Mediterranean countries which are not members of the Union.
3. Where the Council of Europe is concerned, the enlargement which began after 1989 resulted in the accession to the Organisation of three countries from the Mediterranean basin, Albania and "the former Yugoslav Republic of Macedonia" in 1995, and Croatia in 1996.
4. Furthermore, bearing in mind the close relationship which exists between the Mediterranean and Black Sea basins, especially where the environment is concerned, the fact that all the states of the Black Sea basin are either members or special guests of the Assembly is a significant new element. As a result, the Council of Europe is in an ideal position to deal with the problems affecting both basins.
5. What is more, the political importance of co-operation among local and regional authorities in recent times clearly shows the contribution which local and regional authorities can make to sustainable development, stability and peace. It nevertheless has to be said that the, sometimes enormous, differences between the structures of local and regional authorities are an obstacle to effective dialogue and co-operation.
6. In this context, in line with the views put forward in Parliamentary Assembly Recommendation ... (1998) on the same subject, the Assembly expresses its conviction that interparliamentary dialogue and co-operation help to make available, not only to the countries adjacent to the Black Sea, but also to those on the southern shore of the Mediterranean basin,

the Council of Europe's treaties and co-operation mechanisms, which can help to solve the region's problems.

7. The Parliamentary Assembly, which has always supported and encouraged the activity of the Inter-Parliamentary Union in this field, takes the view that joint activities would make it possible to turn to advantage the complementary nature of the activity of both parliamentary bodies.

8. In addition, it is sure that a strategy of interparliamentary dialogue encompassing all the countries of both basins, with which various local and regional authorities from the area would be associated, would enable those responsible for legislation and those who hold elective office in both basins to pool their experience and to introduce common strategies.

9. The Assembly welcomes the fact that one of the aims of the Fifth Conference of Mediterranean Regions, to be held in Montpellier in October 1998, will be precisely that of strengthening the machinery, and going into more detail about the subjects, which would enable this interparliamentary and inter-authority dialogue to be set up in the field of sustainable development.

10. Consequently, the Parliamentary Assembly: i.believes that it would be useful for consideration to be given, in respect of the subjects which most lend themselves thereto, such as the environment, regional policy, culture, migration, etc., to opening certain committee meetings to participation by the equivalent committees of the parliaments of non-member states from the Mediterranean basin; ii.decides to request the Inter-Parliamentary Union to study, in co-operation with the Parliamentary Assembly of the Council of Europe, the scope for co-operation between the two assemblies, and, in particular, to consider associating representatives of the Congress of Local and Regional Authorities of Europe and of the local authorities of the countries on the southern and eastern shores of the Mediterranean with certain activities which are part of the CSCM process (Conferences on Security and Cooperation in the Mediterranean); iii.in the same spirit, wishes to develop its co-operation with the Parliamentary Assembly for Black Sea Economic Co-operation (PABSEC); iv.shares the views expressed by the joint Congress of Local and Regional Authorities of Europe-Parliamentary Assembly group in charge of organising the forthcoming conference of Mediterranean Regions, that it would be useful to change the title of these conferences to "Conferences on interparliamentary and inter-regional co-operation in the Mediterranean Black Sea basins".

II. Draft recommendation.

1. The Parliamentary Assembly has long given attention to the problems of co-operation and sustainable development in the Mediterranean. In particular, it is under its aegis, and in co-operation with the Congress of Local and Regional Authorities of Europe, that the conferences of Mediterranean regions are periodically held, the most recent of which, the fourth, took place in Cyprus in September 1995. These conferences have enabled priority areas for the development of the Mediterranean region to be identified, areas in which Council of Europe activity would be both welcome and beneficial.

2. Following the third conference, held in Taormina in April 1993, the Assembly adopted Recommendation 1249 on co-operation in the Mediterranean basin, in which it put forward several proposals as to the role which the Council of Europe might play in this region.

3. While wishing that the Committee of Ministers show a stronger commitment in favour of a Council of European Mediterranean policy, the Assembly is gratified to note that a rapporteur group was set up in 1995 which - within the same committee - is responsible for issues relating to co-operation in the Mediterranean area.

4. Furthermore, the Assembly welcomes the fact that the CLRAE has already taken practical action to follow up the conclusions of the fourth conference, holding a conference in Bari

(Italy) on "local and regional authorities in the face of Mediterranean migration: from intolerance to development", and takes note of the proposal of the Apulia Region to host an "inter-regional observatory of Mediterranean migration".

5. For its part, the European Union has decided to intensify co-operation in the Mediterranean area. Through the Euro-Mediterranean Conference, held in Barcelona in November 1995, it has initiated a very large-scale partnership with those Mediterranean countries which are not members of the Union.

6. Where the Council of Europe is concerned, the enlargement which began after 1989 resulted in the accession to the Organisation of three countries from the Mediterranean basin, Albania and "the former Yugoslav Republic of Macedonia" in 1995, and Croatia in 1996. Furthermore, bearing in mind the close relationship which exists between the Mediterranean and Black Sea basins, especially where the environment is concerned, the fact that all the states of the Black Sea basin are now associated with the Organisation in one way or another is a significant new element. As a result, the Council of Europe is in an ideal position to deal with the problems, particularly those of a political nature, affecting both basins, by adopting a comprehensive approach to them.

7. As the Black Sea suffers from severe pollution, its vitality is in grave jeopardy. The proceedings of the first Interparliamentary Conference on the Environmental Protection of the Black Sea (Istanbul, 10-12 July 1996), jointly organised by the Parliamentary Assembly of the Council of Europe and the Parliamentary Assembly for Black Sea Economic Co-operation (PABSEC), showed that the pollution generated upstream along the rivers which flow into the Black Sea affect — to some extent, at least — the Mediterranean basin. Hence the benefits of adopting a comprehensive approach to the issue, highlighting co-ordinated parliamentary activities intended to guarantee the sustainable development of both basins.

8. What is more, the Parliamentary Assembly has always supported and encouraged the aim of the Inter-Parliamentary Union (IPU) to hold Conferences on Security and Co-operation in the Mediterranean (the CSCM process), and takes the view that joint activities in this field would make it possible to turn to advantage the complementary nature of the activity of both parliamentary bodies, and, in this same spirit, it also considers that co-operation with the Parliamentary Assembly for Black Sea Economic Co-operation (PABSEC) can make a useful contribution to furthering and deriving benefit from the inter-parliamentary dialogue in the region.

9. It expresses its wish that existing international instruments, on protecting this region's environment, such as the Convention on the Protection of the Black Sea against Pollution (Bucharest, 1992), the ministerial Declaration on the Protection of the Black Sea (Odessa, 1993) and the International Convention for the Prevention of Pollution from Ships (MARPOL, 1973 and 1978), be more widely ratified and effectively respected.

10. Consequently, concurring with the Final Declarations of the 4th Conference of Mediterranean Regions (Limassol, 16 and 17 October 1995) and the Interparliamentary Conference on the Environmental Protection of the Black Sea (Istanbul, 10-12 July 1996), the Assembly requests that the Committee of Ministers take follow-up action on the proposals therein, and, in particular: i. promote the Organisation's values in the Mediterranean, in particular as regards sustainable development; ii. contribute, within the context of this programme, to the promotion of the co-operation programmes set up among local and regional authorities around the Mediterranean, particularly in respect of migratory movements; iii. strengthen the Mediterranean dimension of the dialogue under way within the framework of the Lisbon North-South Centre, particularly by opening, in Limassol (Cyprus), an office responsible for liaison with the countries of the southern shore of the Mediterranean and of the Middle East; iv. encourage and support bilateral and multilateral exchanges, in the sphere of water management, particularly at the level of local and regional authorities, relating

to: a. transfer of knowledge and pooling of experience; b. training programmes for decision-makers and managers; c. the provision of information to, and raising of awareness among, those who hold elective office and representatives of users; d. the raising of users' awareness and education of users so as to enable them to participate in the management of their own resource, especially through non-governmental organisations; v. organise a "Mediterranean and Black Sea Protection Year", modelled on European Nature Conservation Year, in order to make people at every level aware of both seas' problems and to bring into play the ecological awareness of the peoples of every European country and of the countries on the southern shore of the Mediterranean; vi. develop activities with a view to encouraging the Mediterranean countries which have not yet done so to sign and ratify the Convention on the Conservation of European Wildlife and Natural Habitats (Bern, 1979); vii. encourage the Mediterranean states which are not members of the Organisation to accede to the Convention for the Protection of Animals during International Transport and to the Partial Agreement on Major Disasters; viii. promote the signature and ratification of the Council of Europe Convention on Civil Liability for Damage resulting from Activities Dangerous to the Environment (Lugano, 1993).

III. Explanatory memorandum by Mr Recoder.

1. Introduction.

The Council of Europe has always paid great attention to the problems in the Mediterranean. The Parliamentary Assembly's last opinion was expressed by means of its Recommendation 1249 (1994), in which it put forward to the Committee of Ministers a number of initiatives aimed at clarifying and strengthening our Organisation's role in this area. The Council of Europe's evolution and the events which have taken place since 1994, far from making these proposals less valuable, force us all the same to give some fresh thought on these questions in order to incorporate new points of view to our position.

By means of the Euro-Mediterranean Conferences held in Barcelona (1995) and Malta (1997), the European Union has launched a vast Mediterranean co-operation programme. In this context, one must note that the Council of Europe must find a niche which would be its own and in which it could bring an original contribution in line with the values it represents.

On the one hand, different conferences organised by the Parliamentary Assembly in this domain have demonstrated that a reinforcement of inter-parliamentary co-operation would find favourable response throughout the basin. On the other hand, the considerable diversity of models of territorial administration found there makes it difficult for cities, provinces and regions from one shore to find counterparts in their co-operative efforts with the other shore. Hence the interest to associate them with inter-parliamentary dialogue, which could give them a forum that has been unavailable to them so far.

Furthermore, it is now time to note that all the countries from the Black Sea rim are now either members or special guests in our Assembly. If, on the one hand, the two basins – Mediterranean and Black Sea – can represent different characteristics, it is no less true that they are much closer in other areas, notably that of the environment. Insofar as all of the Black Sea Rim countries and most Mediterranean ones now belong to the Organisation, and notably to the Parliamentary Assembly, the Council of Europe could become a political forum particularly well fitted for dealing with the common problems of the two basins.

This report contains, first of all, an analysis of the current situation in these two basins, followed by an overview of the most recent actions that different international organisation have carried out there, and, finally, a series of proposals regarding a stronger and newer Mediterranean policy for the Council of Europe.

2. Analysis of the situation in the Mediterranean – Black Sea Region.

2.1 Disequilibrium and instability in the Mediterranean.

The Mediterranean, cradle of cultures and civilisations and the birthplace of the three main monotheistic religions, was in the past and remains today a crossroads for cultural, human and economic exchanges, a bridge between civilisations which have mutually influenced and enriched one another.

But it also was and still is a place rife with existing and potential conflicts and with economic, social and cultural tensions. Today this state of affairs is mainly due to the great political, social, economic and environmental imbalances which persist in the region, especially, but not solely, on the Mediterranean's southern shores.

Unemployment, poverty and a lack of prospects are leading to the emergence of religious fundamentalism, sometimes taking violent forms, being what young people without a future see as their only tangible reality and hope of salvation.

Political imbalances are perceptible in the Adriatic sub-region, where with the fall of communism unresolved national conflicts have come to the fore and have led to atrocious fighting, as in Bosnia-Herzegovina, or to extreme poverty and the collapse of social structures, likewise with outbreaks of violence, as in Albania. Such imbalances are also to be seen in the Middle East, one of the world's principal trouble-spots, where active or latent conflict is a fact of life, and on the island of Cyprus, where the tensions engendered by a long-standing unresolved conflict periodically flare up.

Rapid population growth threatens the achievement and consolidation of sustainable economic development in the countries concerned and paves the way for the migratory pressures exerted by those seeking a better life elsewhere. In 1950 two-thirds of the population of the Mediterranean basin lived on the northern shores, from Spain to Greece, and the remaining third on the eastern and southern shores, from Turkey to Morocco. As a result of demographic trends, these two areas today have more or less the same proportion of inhabitants, but by the year 2025 the ratio will be exactly the opposite: one third of the population will live in the European part of the Mediterranean, and two-thirds in the African and Asian parts, where there will be a far higher percentage of young people, exacerbating even further the unemployment problems which currently plague those areas. From 1970 to 1982 the populations of the countries in the south and the east grew by 2.5% per year, and in some countries the growth rate even exceeded 3%. Over the same period annual population growth in the north was 1% or less, with the lowest figure - 0.4% - in Italy.

In terms of human resources, in addition to weight of numbers the age difference can be taken into account. This difference will be twice as great by the year 2025: in the south 45% of the population will be under fifteen years old, compared with only 24% in the north. According to statistics collected by Professor Bichara Kader, by the year 2000 the working population of the four countries of the Maghreb will grow by 602,500 per year, whereas by the beginning of the 21st century that of the countries of southern Europe will be falling. The Mediterranean is therefore the European frontier region with by far the highest, most explosive demographic growth.

Along with the Caribbean, the Mediterranean currently has the strongest migratory flows in the world. Until the seventies the countries on the northern shores of the Mediterranean saw significant population movements. However, from then on southern Europe saw a sharp fall in emigration and a rise in immigration, as much for political reasons as for demographic and economic ones. Italy, for example, took in a total of more than one million foreigners, and Spain some 800,000, not to mention France. As Tahar Ben Jelloun points out, the crucial problem for Europe throughout the present decade will be the fate of those emigrants' sons and daughters, the so-called second generation. The young people in question are not immigrants but were born in Europe or came there as children. Yet at the same time they have

been completely uprooted from their culture of origin and are not at all integrated into the new culture.

These second-generation immigrants are at risk of remaining prisoners of a socio-professional situation less favourable than that of their parents: almost two-thirds of these children leave school with a low level of education.

The Mediterranean is also a region of major economic imbalances. In 1990, with less than 45% of the region's population, the four Mediterranean countries of the European Union - Spain, France, Italy and Greece - accounted for 87% of its GDP, and while per capita income in the European countries averages about 10,000 dollars, the countries on the southern shore scarcely achieve 1,200 dollars. This shows that the Mediterranean is also a frontier with the underdeveloped countries of the world, a particularly serious state of affairs if the south's demographic problems, referred to earlier, are borne in mind.

This combination of political, economic and demographic factors, to which other environmental or security-related considerations must be added, is leading the north to close in on itself in such a way that, from the southern point of view, Europe, and in particular western Europe, is perceived as a fortress reluctant to share its prosperity, a group of societies concerned with preserving their enviable standard of living and capable of developing racist, xenophobic attitudes towards migrants. The south sees a Europe turned towards the east, devoting all its efforts to integrating its eastern regions and overlooking the fact that the region on its southern border is rife with conflicts, although that region is separated from Gibraltar by a mere 14-kilometre stretch of sea.

The Mediterranean is a region full of variety with little uniformity in any sense - cultural, religious, political, economic, or in terms of the advance of human rights and fundamental freedoms. It is therefore a region that must be developed on the basis of respect for diversity. The problems, difficulties and disparities within the region may give the impression that it suffers from incurable structural instability, but at the same time can and should prompt us to try to make it a zone of prosperity, co-operation, neighbourliness and tolerance.

Furthermore, the Mediterranean continues to be a heavily polluted sea despite the international efforts carried out since the 1970s to reverse the situation. Its problems are well-known, and the Rapporteur merely wishes to outline them here. As an almost closed sea, it takes decades to renew the Mediterranean's waters naturally, and therefore its capacity to absorb pollution is rather limited. Yet, with the growing population of its coastal countries and the heavy yearly inflow of tourists comes an increase in urban waste and sewage, which for the most part is directly dumped into the sea. Heavy maritime traffic is also a cause for concern: the Mediterranean ranks very high as far as oil pollution is concerned. Last but not least, overfishing remains a problem which helps deteriorate the situation.

This reality can no longer be ignored, a fact which was the principal point made in the recommendation on co-operation in the Mediterranean basin adopted by the Parliamentary Assembly of the Council of Europe in 1994.

2.2 Situation in the Black Sea.

The Black Sea is the biggest inland sea in the world. It is linked in the north to the Sea of Azov and in the south to the Sea of Marmara and the Mediterranean via the Bosphorus, which is both very narrow (1.6 km on average) and shallow (36 m). It is thus a virtually enclosed sea, as deep as 2,000 m in places and with an average depth of 1,240 m.

Several of Europe's major rivers flow into the Black Sea, including the Danube, the Don, the Dnieper and the Dniestr.

The Black Sea basin includes the greater part of 17 countries, six of which border directly on it. The population of this region is some 160 million.

Although its ecosystem is fragile, being vulnerable due to factors such as its shallowness in places, the Black sea had no major problems until the 1970s; on the contrary it enjoyed remarkable biodiversity. Overfishing, man-made pollution, eutrophication and intense shipping traffic are some of the causes of damage to the environment, which has now reached alarming proportions.

The first positive consequence of the major geopolitical changes of recent years has been the realisation of the seriousness of the problem, whether by international organisations, research institutes, NGOs or certain of the coastal states. This has encouraged the pooling of efforts and the establishment of a net work with the common aim of recovering this extremely rich ecosystem.

2.2.1 The major problems.

The Black Sea has always had an extremely rich ecosystem. The great rivers already mentioned have always discharged nutrients which have been considered a special contribution to the quality of the ecosystem. These nutrients have been the source of substantial production of phytoplankton, the first element of the marine food chain. Precipitating phytoplankton give rise to substantial bacterial activity on the seabed, consuming all available oxygen and leading to the complete disappearance of all life forms below a depth of 180 m.

This has always been a feature of the Black Sea which, apart from being the most "anoxic" in the world, has always had a mid-surface area of great richness and diversity.

Unfortunately, for nearly 30 years, the Black Sea environment has been suffering unprecedented damage due to the conjunction of various phenomena, of which I shall mention the most important.

Pollution by large rivers plays an important part in the Black Sea's deterioration. Firstly, owing to over-fertilisation of farmland in their catchment basins, they discharge much too large amounts of nutrients such as nitrogen and phosphorus, causing excessive proliferation of phytoplankton (eutrophication). In moderate amounts, such phytoplankton has been considered beneficial to marine ecosystems, but too much has caused the system to "seize up" and had a devastating, suffocating effect.

A typical example is the Danube which in 1990 alone deposited 40,000 tonnes of phosphorus and 50,000 of nitrogen into the Black Sea, 10 times more than in 1960.

But the management of the region's water resources has also had a significant contributory effect. River flow management for various purposes in the former Soviet Union has diminished salinity in the Sea of Azov and substantially reduced exchanges with it. In the Danube Basin, major engineering works, including the hydroelectric dam reservoir have sharply reduced the amount of sediment carried down to the Black Sea.

This phenomenon, combined with overfishing has led to an alarming depletion of resources, turning the once rich and diversified marine environment into a poor habitat in which species are less and less numerous. One example may suffice to illustrate this point : 900,000 tonnes of fish land in 1986, 100,000 tonnes in 1992 ...

Another example illustrates the seriousness of deterioration in terms of quality : in the waters of the Black Sea in 1965, there were still some twenty species of fish. By 1985, following the changes which have occurred since 1989, has become the only way out for oil.

Oil pollution is another problem for the Black Sea, for which, as has been said, the Bosphorus is the only exit to the oceans. Mainly because of the changes which have taken place since 1989, the Bosphorus has become a compulsory passage for oil tankers.

The Bosphorus being 700 m wide at its narrowest point, navigation through the Strait is very dense, even congested. Currently, over 90 foreign vessels cross the Strait every day on average, and the trend is ever-increasing. According to experts, daily traffic, which includes

transport of oil and hazardous substances (35% of all traffic are tankers), could increase by as much as 50% when new canals link the Danube to the Baltic.

This traffic is polluting enough in itself owing to its intensity and the effects which "ordinary" discharges are bound to have on water quality. But, alas, in addition to this pollution which - although "usual" - is not negligible, the Black Sea also regularly suffers accidents or deliberate dumping which have occasionally caused oil slicks of some magnitude.

There is now also the problem of supply routes for oil and gas from the Central Asian fields which, being no longer able to use the former Soviet ports, are obliged to transit via the Bosphorus. For the moment, two possibilities are envisaged for such supplies : pipeline and a combination of ship and pipeline.

The latter would obviously increase traffic and automatically also increase the risk of ecological damage. According to some estimates, it would multiply tanker traffic in the region by a factor of 8. According to some coastal states, including Turkey, shipping in the strait should be eliminated by means of a pipeline across the Caspian and Mediterranean Seas.

Discharge and dumping of waste is another danger to the Black Sea environment. Waste is discharged into the Sea by the rivers which transport sewage from many of the towns they flow through, or directly by industry. The problem of urban sewage transported by the rivers illustrates the close correlation that has to be maintained between various kinds of complementary action.

In this respect, the example of the Danube is eloquent. Knowing that the Danube is responsible for 80% of pollution in the Black Sea and that various schemes are under way in the Danube Basin, we can see that any co-operation concerning the Black Sea and the Danube must be co-ordinated in order to achieve synergy.

But waste dumping is also a crucial problem. Unfortunately, not only the coastal states are responsible, but also other states from outside the basin. There is clear evidence of relatively frequent dumping of toxic waste by vessels flying flags from elsewhere.

The question of radioactive waste also deserves careful attention, whether it be land-based, as from Chernobyl, or from the discharge or dumping of drums of radioactive materials.

From this brief overview, it can be seen that the Black Sea is subject to many and varied assaults, mostly due to human activity. In recent decades, resources have been exploited without thought for their renewal. For the time being, the effects seem to be confined close to the sources of pollution, without the basin's overall ecology being irreversibly affected, but projections based on current data show clearly that if damage were to continue at the present rate, the situation would rapidly become dramatic and probably irreversible.

2.2.2 International solidarity.

Unfortunately, the situation is coming to a head now, at a time when the Black Sea countries are having to face crucial problems of political, economic and social transition and care little for the gravity of the situation and are in any case incapable alone of shouldering the economic burden of any substantial action.

The Black Sea's resources are shared between six coastal states - Bulgaria, Georgia, Romania, Russia, Turkey and Ukraine - who should be responsible for managing them. But, as in the case of rivers, it is important to take into account the whole catchment basin, in which case 11 more countries must be added to those six.

These countries certainly have a "neighbourly" responsibility for the Black Sea. But solidarity surely goes further than these 17 countries directly concerned.

At the Conference held in Istanbul in July 1996, sponsored by the Assemblies of the Council of Europe and Black Sea Economic Co-operation on the Black Sea environment (see below), it was shown that the Black Sea has a direct influence on the Sea of Marmara and, above all,

on the Mediterranean. As the sea level is higher than in the Mediterranean, Black Sea pollution overflows directly into the Mediterranean.

Another example is provided by the Danube, which is mainly responsible for pollution of the Black Sea. Surely Germany, Austria and Hungary bear a share of responsibility for the state of the Black Sea environment ?

2.2.3 Mounting a programme for the Black Sea environment.

At the beginning of the 1990s, the Black Sea coastal states grasped the opportunity afforded by the region's new political configuration to draft the Convention on the Protection of the Black Sea against Pollution.

This Convention, signed in Bucharest at the beginning of 1992, was ratified by the six parliaments at the beginning of 1994. It was designed as an outline convention and has so far been supplemented by three protocols on three crucial problems : land-based pollution, dumping of waste, and joint action policy in the event of disasters such as major oil spills.

Finding that the convention was not sufficiently strict in terms of timetable and priorities, the environment ministers of the six coastal states signed a Declaration on the conservation of the environment of the Black Sea, at Odessa in April 1993.

Thanks to joint financial backing from various organisations (World Bank, UNEP, UNDP, European Union ...) and countries such as France, Austria, Canada and Japan, funds totalling nearly 100 million dollars have enabled the Black Sea Environment Programme (BSEP) to be launched.

The first schemes launched under this programme have sought to improve the means available to the coastal states for assessing and managing their environment and to support the drafting and implementation of new legislation. Another of the main aims of the Programme has been to restore the necessary institutional links at local, national and international level and to establish a network of thematic working parties based on regional activity centres in each of the coastal states. Each centre works on a specific theme within a working party in which each of the coastal states is represented. The specific themes correspond to the major issues described above.

The BSEP has also established close links with other organisations working in the same fields. For the moment these are international NGOs, Black Sea Economic Co-operation (BSEC), UN Specialised Agencies.

3. Recent Activities.

3.1 Council of Europe.

3.1.1 4th Conference of Mediterranean Regions (Cyprus, 20-22 September 1995).

Among the Council of Europe activities devoted to Mediterranean co-operation the Conferences of Mediterranean Regions organised by the Parliamentary Assembly and the Congress of Local Authorities illustrate clearly the interest of both bodies in the subject.

The Mediterranean, despite constituting a historical and cultural entity, remains an important source of instability made all the more acute by a widening gap in economic development and the absence of political structures in some countries of the southern shore, which make the exercise of democracy and the maintenance of peace difficult. The Parliamentary Assembly and the Congress of Local Authorities set out to contribute to the provision of conditions for satisfactory development and preservation of the region's historical and cultural inheritance by organising regular "Conferences of Mediterranean Regions" as a means of providing those regions with an opportunity to co-operate with each other in surmounting common problems.

After the first three conferences, in Marseilles (1985), Malaga (1987) and Taormina (1993), the fourth assembled in Nicosia and Limassol (Cyprus) on 20-22 September 1995 on the

theme of "Sustainable development in the Mediterranean: environment, demography and migration" (see Appendix 1).

The conference themes were introduced by top-quality presentations by leading scientists and academics which made for fruitful political discussion.

The subject of intolerance, racism and xenophobia was dealt with at a Round Table, resulting *inter alia* in an invitation from Puglia (Italy) to hold a major conference in Bari on the theme of intolerance in the Mediterranean (see 3.1.6, below).

It emerged clearly from the discussions at this round table that the difficult social and economic situation in most of the Mediterranean countries is an aggravating factor in phenomena of social or racial intolerance, but that improving living conditions is not the only solution. It is unanimously agreed that solutions must also be sought by political, cultural and legal means.

With regard to population and migration problems, the reports showed that the characteristic features of demography in the Mediterranean are population ageing and a falling birth rate in the north, and a young population facing major problems in the south.

The difficult general socio-economic situation is reflected in high unemployment affecting all strata of the population, but in the south it is the cause of substantial migration. Apart from the socio-cultural problems it causes, for the south migration also means the loss of young graduates who prefer to leave in search of better job prospects elsewhere.

On this subject, the Conference emphasised the need to put into effect certain proposals already put forward in the Council of Europe, such as the setting-up of a "Mediterranean Migration Foundation" in Sicily, as proposed by the third Conference in Taormina.

The Conference also stressed the importance to the Mediterranean countries of the problem of water resources management and the priority that should be given to all forms of co-operation that can help protect this vitally important resource, both quantitatively and qualitatively.

Overexploitation of resources is certainly the most serious and the most urgent problem for the countries of the southern shore, which have already by far exceeded their capacity. Consequently, since population growth and rapid urbanisation are bound to increase requirements, they will have to rely on the most advanced techniques of sewage and seawater treatment.

The Conference proceedings demonstrated that it is essential to establish interterritorial co-operation as part of a genuine Mediterranean strategy, for which the Council of Europe would be an appropriate framework.

Such a strategy could focus on the Council of Europe's special fields such as the defence of democracy, human rights, minorities and the rule of law. The Council could also place at the disposal of non-member Mediterranean states the legal instruments which can help achieve the objectives referred to above.

Moreover, the Conference specifically requested the Committee of Ministers of the Council of Europe to open for signature the convention on interterritorial co-operation proposed in 1993 by the Standing Conference (since become the Congress) of Local and Regional Authorities of Europe to complement the Madrid Outline Convention on Transfrontier Co-operation.

The 4th Conference of Mediterranean Regions concluded with the adoption of a Final declaration (see Appendix 2). The next Conference - for which preparations are already well under way - will be held in Montpellier in autumn 1998 at the invitation of Languedoc-Roussillon Region, on the themes of interregional co-operation, democratic security and peace, and sustainable development.

The Rapporteur is convinced of the value of developing Mediterranean co-operation between regions and through interparliamentary dialogue. Such regional and parliamentary co-operation would naturally fall within the range of the Council of Europe and, importantly,

would complement that undertaken by the European Union with the Euro-Mediterranean Conference held in Barcelona in November 1995 (see below).

3.1.2 Hearing on Mediterranean co-operation (Thessalonika, 28 May 1996).

By its very nature, the Parliamentary Assembly, whose members are drawn from national parliaments, can provide an ideal platform for dialogue with southern-shore counterparts.

Where territorial authorities are concerned, the difference - or absence- of such structures on the southern shore makes co-operation less easy. Consequently, opening dialogue at this level also entails co-operation with the aim of establishing or reinforcing institutional or administrative structures of a kind to guarantee the exercise of genuine "proximity" democracy.

However, it is important to remember that, despite arousing great interest, the Conferences of Mediterranean Regions have suffered from the imbalance between north and south in terms of the organisation of territorial authorities. As a consequence, the regions, departments or provinces of the northern shore do not always have any counterpart on the southern shore or, where they do, their powers are often considerably different.

This structural imbalance is certainly one of the reasons for the poor attendance by representatives of the southern shore and hence the difficulty of establishing systematic institutional dialogue.

But this fact merely confirms that the Council of Europe has a part to play in establishing such structures and this is where dialogue between legislators comes in. It is with this in mind that the committee has wished to hold exchanges of views with parliamentarians from the southern shore in order to discuss concrete problems facing all the Mediterranean countries, but also to discuss the institutional and administrative structures necessary to optimum co-operation.

The committee accordingly decided to hold a hearing on the problems of water management and desertification and to invite representatives of southern shore parliaments. For practical reasons, it was decided to issue this first invitation to the parliaments of the Maghreb countries.

At this gathering, which was held in Thessalonika in May 1996, the problems mentioned above were introduced by experts and gave rise to practical discussions including the possibility of co-operation between the Parliamentary Assembly and the parliaments of those countries.

Those discussions, as well as informal contacts, give reason to suppose that a Parliamentary Assembly initiative to create the conditions for regular dialogue at parliamentary level would be both useful and welcomed by the parliaments concerned.

Bearing in mind the obstacles that might arise over certain sensitive political issues, co-operation could focus on certain specific subjects falling within the scope of the Assembly's various "technical" committees.

Where the Committee on Environment, Regional Planning and Local Authorities is concerned, it would be interesting for example to hold periodic meetings with representatives of their counterparts to review subjects of interest and single out forms of co-operation to be developed.

3.1.3 1st Interparliamentary Conference on Protection of the Environment in the Black Sea (Istanbul, 10-12 July 1996).

Since its creation in 1992, the Parliamentary Assembly of Black Sea Economic Co-operation (PABSEC) has always paid special attention to the environmental situation of the Black Sea and the surrounding region.

The region's extremely serious plight calls for swift action and the setting-up of suitable co-operation machinery. From the various reports available it is clear that the problem stretches

far beyond the frontiers of the Black Sea area. Heavy pollution, due to the alarming state of the Danube and other major rivers; the objectively measured effects of this pollution on the Mediterranean show unequivocally that it is indispensable to tackle integrated management of the area according to a pan-European, world-scale approach.

Since its enlargement from 1989 onwards, the Council of Europe has grown to include among its members virtually all the Black Sea coastal states and so bears a responsibility in the co-operation to be organised to secure sustainable development of the Black Sea region.

It was in full awareness of this responsibility that the Parliamentary Assembly decided, in co-operation with PABSEC, to organise the first Interparliamentary Conference on the Protection of the Black Sea Environment, which took place in Istanbul on 10-12 July 1996 (see programme in Appendix 3).

The conference proceedings covered three main themes: review of the main environmental problems in the Black Sea; measures to stop pollution, prevent damage to the environment and foster its recovery; and environmental legislation.

Being a parliamentary conference, its proceedings were mostly concerned with action by parliaments to draft and adopt legislation geared to the satisfactory implementation of environment protection policies.

The conference also emphasised the role of the different levels of government, recognising the fundamental importance of local authorities, but also of national and international NGOs.

The reports - often very specific and well documented - highlighted the seriousness of the situation and the many problems which play a part in the degradation of the regions's environment, but also and above all the close correlation between them all. For example, Professor Mario Pavan's report brilliantly demonstrated the direct connection between the Black Sea and the Mediterranean and the need for a comprehensive approach to the "Mediterranean/Black Sea System".

Apart from the objective data proving the connection between the two, the Rapporteur believes that the Council of Europe is the appropriate place to launch region-wide action embracing both basins. The coastal states together account for almost half the Council of Europe's members, which shows the potential importance of such co-operation.

The Conference - which the President of the Assembly attended in its entirety - concluded with the adoption of a Final Declaration (see Appendix 4) which included an appeal to the Council of Europe to proclaim 1998 "Mediterranean and Black Sea Protection Year".

3.1.4 Mediterranean Conference on Population, Migration and Development (Palma de Mallorca, 15-17 October 1996).

This conference was organised by the Council of Europe's European Population Committee in response to Parliamentary Assembly efforts to find ways of coping with demographic imbalance and disparities in socio-economic development in the Mediterranean.

While welcoming the important initiatives taken by the European Union in connection with the Euro-Mediterranean Conference in Barcelona, the conference concluded that a comprehensive Council of Europe strategy for the Mediterranean was indispensable.

The Committee on Migration, Refugees and Demography drew up a report on follow-up to the conference which was discussed by the Standing Committee at its meeting in Bucharest on 28 May 1997 and resulted in the adoption of Recommendation 1329 (1997).

This recommendation asks the Committee of Ministers to support the process of institutional joint consultation between Europe and the non-member coastal states by inviting them to participate in the Council of Europe's work as observers.

3.1.5 Conference on Sustainable Development in the Black Sea (Odessa, 11-12 November 1996).

As regards activities on the situation in the Black Sea basin, the rapporteur wishes also to mention the Conference held in Odessa on 11-12 November 1996 on sustainable development in the region.

It was organised by the Council of Europe intergovernmental sector, the German federal Ministry of Regional Planning, Building and Urban Development and the Ukrainian Government, in co-operation with the network of spatial planning research institutes of eastern and central Europe. It emphasised the need to formulate strategies for integrated approaches to spatial planning policy in the region and the value of placing the experience, achievements and instruments of the Council of Europe at the disposal of the countries of the region.

The rapporteur particularly wished to draw attention to this meeting because he firmly believes that such an approach can not only contribute to sustainable development in the Black Sea region, but can also help bring about a comprehensive approach to the Black Sea/Mediterranean System conceived in the light of the comprehensive, integrated spatial development approach formulated by the Council of Europe nearly 20 years ago and reasserted since by the Parliamentary Assembly.

The Conference concluded with the adoption of a Final Declaration (see appendix 5) calling upon the Council of Europe to give the Black Sea countries the support they need in the formulation of their spatial development strategies, which should moreover fit into a pan-European programme.

3.1.6 International Conference on "Local and Regional Authorities in the face of Migratory Flows in the Mediterranean region: from intolerance to development".

This conference, organised by the Congress of Local and Regional Authorities of Europe at the invitation of the Region of Puglia, stems directly from the proposals made in the final declaration of the 4th Conference of Mediterranean Regions held in Limassol in 1995. Participants were able to study the models of integration of immigrants put into place by local and regional authorities which face considerable inflows of immigrants. The final declaration (see appendix 6) made an appeal to the Council of Europe for it to pay more attention to demographic, political and economic problems around the Mediterranean, and invited it to promote co-operation between local and regional authorities in the basin. Further to the conference, the Region of Puglia is setting up a foundation devoted to these topics, which could bear the following name : "European interregional centre for monitoring migrations and promoting trans-frontier co-operation in the Mediterranean".

3.2 European Union.

3.2.1 Euro-Mediterranean Conference.

Any discussion of multilateral European efforts in the Mediterranean basin must pay special attention to and take due account of the activities being pursued by the European Union within its own sphere of action. It should be pointed out that the fifteen-member Union is no longer exclusively concerned with the changes in eastern Europe, and therefore dedicated to strengthening the new democracies, but has become aware of the threat posed to its own stability by the under-development of the Mediterranean region and is attempting to remedy that region's long-standing relegation to the sidelines. This new outlook has led to a decision to step up co-operation in the broader sense.

However, before that decision could be taken the differences existing within the Union had to be overcome. On one side, there was the attention of all kinds that the countries of eastern Europe needed, and still need today, which caused the countries on the Mediterranean's southern shore, and above all those of the Maghreb, to feel not only that Europe was ignoring them but even that it was turning its back on them. On the other, there was the position of the

Mediterranean countries of Europe, which were well placed to monitor the situation and to foster integration and which, seeing that they were the first affected by what happened in the region and the most exposed to the dangers of widespread destabilisation in neighbouring areas, called for the Union to rebalance its policy between the two regions of prime importance to its security.

The fall of the Berlin wall in 1989 and its consequences - German reunification and the geopolitical reorganisation of eastern Europe; the Gulf war and its impact on Euro-Arab relations; the Algerian crisis and the potential risks it entails for the whole of the Maghreb; and the development of Islamic militancy, frequently with anti-western overtones, which feeds on the worsening economic situation and the population growth described above, finally convinced the European Union that it must develop such a policy, while of course not forgetting the need to reintegrate the countries of central and eastern Europe into the European area.

From the point of view of the European Union, the rediscovered need to co-operate with the countries south of the Mediterranean and promote their development is to some extent bound up with a security rationale: greater wellbeing will reduce migratory pressure, weaken the influence of Islamic fundamentalists and, therefore, alleviate the danger of internal conflicts spreading outside the region.

There is no doubt that this new attitude was influenced by the domestic situation in Algeria and the outbreaks of Islamic extremism in Egypt and Turkey.

However, the European Union also has a genuine economic and political interest in fostering the creation of a prosperous greater Mediterranean area, since the region is rich in natural resources which Europe needs, its population growth poses a serious problem, the countries concerned already trade on a large scale with the EU, and they represent an interesting potential market which, in the event of a resumption of economic growth and a rise in demand matched by the ability to pay, could have a very stimulating effect on European exports.

The Euro-Mediterranean Project, which has its origins in the Barcelona Conference of 1995, aims to further the efforts to transform the region into an area conducive to the sustainable, integrated economic and social development of all the countries of the Mediterranean basin and, to achieve this ambitious objective, includes a series of measures, which can be classified according to more tangible objectives: political co-operation and security, as means of establishing a common area of peace and stability; economic and financial co-operation, as means of creating an area of shared prosperity; and co-operation in the social, cultural and human spheres to facilitate the development of human resources and foster intercultural understanding and exchanges between the different countries' civil societies. These latter objectives are also particularly relevant to the Council of Europe's interests and responsibilities within its sphere of action.

The following elements of this project have been identified by Professor Gabriel Guzmán as reasons for optimism; they also provide the Parliamentary Assembly of the Council of Europe with food for thought: The project represents a multilateral approach, the outcome of a maturation process, which complements and provides a framework for the separate bilateral agreements concluded with each country.

It includes an ambitious plan to set up a free trade area by the year 2010, which must gradually be given shape and implemented as the background against which exchanges within the area will develop. When the time comes this free trade area may bring together 600 to 800 million individuals from 30 to 40 countries.

It entails a significantly higher level of financial co-operation, with 4,685 million ECU earmarked for the 1995-99 period, a figure which may be increased, notably by resources made available by the European Investment Bank (EIB) and bilateral contributions from the Union's member states.

It balances the EU's external relations, which in the sphere of financial co-operation attached far more importance to the countries of central and eastern Europe than to those on the shores of the Mediterranean.

It broaches extremely important political issues, including a commitment to strengthen democracy and respect for human rights and to promote regional security, with the aim of laying the foundations of a stable, safe Mediterranean area.

It encompasses co-operation in the economic sphere, seeking to modernise economic and social structures, to promote entrepreneurial capacities in the domestic economies, to set up semi-public companies, to encourage women to participate in economic development, to improve infrastructure, etc.

It entails an undertaking to devise a programme of priority environment protection measures and to marshal the appropriate technical and financial support.

It includes an innovative initiative in the social and human field, with the aim of helping to improve training schemes and exchanges at the levels of civil society, political and cultural circles, universities, trade unions, businesses, the media, etc.

3.2.2 Follow up to the Conference : Euro-Mediterranean Partnership.

The European Union has started setting up the new Partnership announced in the Final Declaration of the Euro-Mediterranean Conference held in Barcelona. The initiatives taken are very important. Some of the projects launched in the context of this partnership have already been concluded. Work is progressing at considerable pace.

In the spring of this year the second Euro-Mediterranean ministerial conference was held in Malta (15-16 April). Participants took stock of the work completed and underlined their support for its continuation, indeed the strengthening of the Partnership. An obvious sign of this willingness is the statement made in the final declaration according to which participants would like to earmark 4.685 million ECUs from EU funds to finance it.

However, one could define the Euro-Mediterranean Partnership as still a largely inter-governmental initiative. The European Parliament has taken steps to associate itself with the Partnership, a move which the participants have welcomed. However, the concrete contents of this association have yet to be defined.

As regards the association with local and regional authorities, one notes the absence of initiatives at the date of the Malta conference and the temporary suspension, because of administrative difficulties, of programmes aimed at financing decentralised co-operation in the Mediterranean.

4. Current thinking at the Council of Europe.

4.1 Parliamentary Assembly.

The Parliamentary Assembly has always manifested a sustained interest for co-operation in the Mediterranean and, with this conviction, has wished, *inter alia*, to organise jointly with the CLRAE conferences on Mediterranean Regions.

Faced with many initiatives launched and set up in this area in the framework of various organisations, but especially following the European Union's Euro Mediterranean Conference, the Council of Europe should focus on issues which are within its sphere of competence and which can be dealt with at the institutional levels which are specific to the organisation.

In this spirit, the Committee has deemed it interesting to develop dialogue with Parliaments and local authorities from the basins's southern and eastern shores. Such a dialogue should make possible, on the one hand, concrete co-operation on some particularly suitable matters such as the environment, culture or migration problems, and, on the other hand, help to put

into place the mechanisms and structures that will contribute to ensure stability and peace in the region.

By focusing on inter-parliamentary and inter-regional dialogue and on developing it, the Council of Europe can bring a contribution that is specific and complimentary to the co-operation carried out by various other organisations.

As to that which most particularly concerns co-operation with the IPU, which is at the origin of the CSCM process, which consists in periodically organising conferences on co-operation and security in the Mediterranean, the Rapporteur is convinced that the approach of both assemblies is complementary.

This complementary nature is even more interesting in that it appears now useful to deal with Mediterranean countries by means of a global approach encompassing the Mediterranean and Black Sea basins, and that countries bordering the Black Sea are all members of the Parliamentary Assembly and the Interparliamentary Union.

4.2 Congress of Local and Regional Authorities of Europe.

In 1996, the CLRAE adopted a Resolution and a Recommendation which follow up to the 4th Conference of Mediterranean Regions (Limassol, 1995) and in which the Congress made proposals as to the Council of Europe's Mediterranean policy.

Resolution 36 (1996) underlines its commitment to formulating a Mediterranean of Europe for the Council of Europe. The Congress states it would welcome more support for local authority activities around the Mediterranean. It also suggests that actions should be undertaken to promote the European Charter of Local Self-Government in the south shore, and declares its readiness to contribute to the Barcelona process in the field of inter-territorial co-operation.

In its Recommendation 21 (1996), the Congress insists on the need to adopt a Mediterranean policy for the Council of Europe and notably to put into place co-operation programmes which are complementary to those for Central and Eastern Europe. It requests for that the support of the Parliamentary Assembly.

In September 1997, the Committee of Ministers replied to this Recommendation and proposed to hold a dialogue with the Parliamentary Assembly and the CLRAE in autumn 1997 with a view to preparing the fifth conference of Mediterranean Regions.

4.3 Views of the Committee of Ministers and the Rapporteurs Group.

The Report on Co-operation in the Mediterranean Basin that the Committee submitted to the Assembly in September 1994, and the contributions of six other committees, have brought to light the fact that the majority of the activities developed by the Council of Europe in the field of Mediterranean co-operation, have been the fruit of concrete initiatives which do not fit into an overall policy of the Organisation in that domain.

Aside from this observation, the Assembly had indicated all interest in a coherent approach and above all in the role that such an approach could bring to stability and to the development of peace and democracy in the region. Therefore, in its Recommendation 1249 (1994) the Assembly formulated the wish that member country governments engage in a policy of co-operation in the Mediterranean basin to be set up within the Council of Europe.

While expressing some interest in this question, the Committee of Ministers did not share the Assembly's will to see the Council of Europe follow this road. In its response (Doc. 7264) to Recommendation 1249 (1994), it shared the Assembly's view to assure stability and democratic security in the Mediterranean basin thanks to solidarity and co-operation between the two shores.

Yet, as far as ways of co-operating are concerned, the Committee of Ministers suggested that southern shore countries become observers or associate members of certain legal instruments

and that they be invited to joint the partial agreement on which the Council of Europe's North-South centre is based, which in its specific sphere of competence, can play a full role in the region, but it pointed out that these countries have not shown up to the present a great interest in becoming parties to certain conventions.

On the other hand, one can welcome the Committee of Ministers' decision to set up an internal ad hoc working party charged specifically with following the evolution of the Council of Europe's relations with the states concerned. When drawing up the party's terms of reference, the Committee of Ministers also determined the domains where the relations could be developed if the coastal states showed the desire. It specified that this could relate, inter alia, to the setting up of democratic institutions, to the promotion of the rule of law and human rights, to migrations, the environment... Since the constitution of this working party within the Committee of Ministers, one can hope that it will be more inclined to paying attention to Mediterranean issues.

One of the first positive signs was certainly that the group was represented by its President at the 4th Conference of Mediterranean Regions, which was held in Cyprus in September 1995. But, unfortunately, one most at the same time deplore the fact that the Committee of Ministers has not followed the proposals made on the occasion of that same conference, and has not deemed it useful to take the necessary steps to try to associate the Council of Europe with the Euro-Mediterranean Conference organised by the European Union in Barcelona in November 1995, and with the vast co-operation programme with southern shore countries which resulted from it.

To the Committee's great disappointment, the participation of the Council of Europe was limited to sending an extremely succinct and factual document in which stock was taken of different activities and initiatives of the Organisation in this domain.

Currently, the Committee of Ministers has been sent the latest texts adopted by the CLRAE and the proposals made therein, which its Rapporteurs Group is considering.

5. Proposals as to future co-operation.

The 1st Inter-Parliamentary Conference on Security and Co-operation in the Mediterranean, held in Malaga in 1992, revealed the need for a security and co-operation dynamic peculiar to the Mediterranean, so that the region, which remains one of the hubs of world peace, will not degenerate into a place of destructive polarisation or become the dividing line between north and south, but quite the opposite - a contact zone.

The idea of Mediterranean co-operation has been taking shape both in intergovernmental relations and in exchanges among the region's inhabitants. On the northern shore, the OSCE, the European Union, NATO and the Council of Europe itself have, to differing extents, devised a specific Mediterranean policy. On the southern shore, there have been similar signs of a growing awareness of the external and internal reasons for the inadequate level of Euro-Mediterranean co-operation and of the outlook for the future. In this connection, attention should be drawn to the Forum for Mediterranean Dialogue and Co-operation held in Alexandria in July 1994.

Mediterranean co-operation initiatives are fast taking shape as a result of the governments' and the international organisations' realisation that the region is not only behind with its development but is also of importance to world, and particularly European, stability.

All this goes to show that, as was pointed out in Recommendation 1249 (1994), the Mediterranean basin is a region of paramount importance for Europe, and therefore for the Council of Europe. This brings us to the conclusion that our organisation should devise a Mediterranean project, just as other international organisations for which Europe is a *raison d'être* have done or are doing, a project which would be designed not so much to ensure that the Council of Europe's ideals are taken on board by those European countries of the

Mediterranean basin where such values are lacking, since this is already the purpose of the activities normally carried on by the various entities that make up the Council itself, but to spread those ideals to the rest of the region by establishing solid ties through co-operation and exchanges.

The Council of Europe's Mediterranean project must set itself the objective of promoting and strengthening democracy, fundamental freedoms and human rights in the Mediterranean region, encouraging dialogue and exchanges between civilisations, cultures and religions as a necessary step towards mutual understanding and respect, and helping to establish a climate of security based on good-neighbourly relations and mutual trust.

At the same time, as it has already been said, the Council of Europe must from now on draw the conclusions of its enlargement in the Black Sea Basin which is now part of the territory of the Organisation. Insofar as this basin and that of the Mediterranean present common problems, the Council of Europe constitutes an appropriate forum to deal with them.

5.1 Fifth Conference of Mediterranean Regions.

The Rapporteur is convinced of the need to convene a 5th Conference of Mediterranean Regions which marks an evolution in the Organisation's Mediterranean policy.

To this a combined working group of the CLRAE and the Parliamentary Assembly has been set up to organise it. The group has put forward a double-pronged structure for the conference in order to take account of the ideas the Rapporteur reflects in his report.

Thus, in order to keep in mind the new geographical dimension of the Council of Europe, the Conference could dedicate a day of analysis to sustainable development problems in the Black Sea – Mediterranean system, and most particularly to those concerning protection of the environment. On the second day, participants could give some thought to the role that the Council of Europe might play in these domains. Firstly, it would come to analysing which Council of Europe treaties could possibly contribute to resolving the problems mentioned in this report (and how). Secondly, it is necessary to evaluate whether the Council of Europe can contribute, in view of its experience in this domain, to setting up a forum for political dialogue grouping together parliaments and other inter-parliamentary organisations of the two basins, in order to pool sustainable development strategies for the region. Lastly, it is necessary to evaluate the interest of associating with representatives of local and regional authorities from the two basins and study the best formula for such an association.

The Rapporteur welcomes and supports the proposal of the combined group of the Parliamentary Assembly and the CLRAE, to change the title of these conferences in order to better reflect their structure and goals. The generic name proposed, i.e. "Conferences on inter-parliamentary and inter-regional co-operation in the Mediterranean and Black Sea", albeit more complicated than the previous one, has the virtue of being more precise.

5.2 Conclusion.

As far as the environment and, to a lesser extent, sustainable development, are concerned, the Mediterranean and the Black Sea have very similar problems and are closely intertwined, to the extent that one could speak of a single "Mediterranean-Black Sea System".

This should be born in mind when dealing with problems, environmental and other, which affect both basins.

All of the Black Sea Rim countries are now members or special guests of the Council of Europe and therefore have access to the Organisations forums and treaties. Although the same cannot be said about Mediterranean countries, it is nevertheless true that the Organisation has paid much interest to Mediterranean affairs and constantly sought new partnerships in that area.

Local and Regional Authorities from both basins are co-operating actively among themselves. However, there is no forum representing local and regional authorities from all of the Mediterranean and the Black Sea. Because of this, and because the structure and responsibilities of local government vary considerably country-by-country, they find it difficult to share their experience and co-ordinate their effort.

All this leads the Rapporteur to think that the Parliamentary Assembly should be instrumental in developing a political dialogue regarding the various problems which affect the Mediterranean and the Black Sea, open to both Parliaments and local and regional authorities. A first step in this direction could be for the Parliamentary Assembly to invite members of parliament from the southern shore of the Mediterranean to attend some of its committee meetings. Further dialogue could take place in the framework of the 'Conferences of Mediterranean Regions', which could be renamed to reflect this new policy.

Reporting committee : Committee on the Environment, Regional Planning and Local Authorities.

Budgetary implications for the Assembly : None.

Reference to committee : Permanent mandate and Doc. 6618, Reference No. 1789 of 30 June 1992.

Draft resolution and draft recommendation adopted by the committee on 11 December 1997.

Members of the committee : Mr Briane (Chairman), Mr Ruffy (Vice-Chairman), Ms Aytaman (Vice-Chairperson), Ms Severinsen (Vice-Chairperson), MM. Abdulatipov, Akçali, Andreoli, Assis Miranda, M Blaauw, Ms Blunck, MM Boka, Cerny, Sir Sydney Chapman (Alternate: Pickles), MM Chircop, Christodoulides, Ms Ciemniak, MM Ciupaila, Cox, Ms Dromberg, MM Erroi, Feldmann, Frunda, Giannattasio, Gregory, Gyorivanyi, Haraldsson, Hoeffel, Ms Jaruga-Nowacka, Mr Johansson, Ms Johansson, MM Koci, Korakas, Kovacevic, Kukk, Martinez Casan, Minkov, Molnar, Mota Amaral, Mozetic, Olivo, Penz, Plattner, Prokes, Prosser, Prusi, Rakhansky, Recoder, Ms Riess-Passer, MM Rise, Samofalov, Shishlov, Skoularikis, Sobyenin, Staes, Steolea, Svoboda, Theis, Toshev (Alternate: Ivanov), Valkeniers, Woltjer, Yamgnane, Zierer.

The names of those members present at the meeting are printed in italics.

Secretaries to the committee : Mrs Cagnolati-Staveris, Mr Grau Tanner, Mr Chevtchenko.

<http://pao.gsfc.nasa.gov/gsfcearth/pictures/earthpic.htm>



11. The nato committee on the challenges of modern society.

<http://www.nato.int/ccms/p00/tor.htm>

PILOT PROJECT. REVIEW OF ONGOING BLACK SEA PROJECTS FOR THE PLANNING OF FUTURE ACTIVITIES.

BACKGROUND.

I Why the Black Sea?

The Black Sea constitutes a unique marine environment. It is nearly land locked and the ventilation of the deep waters by lateral influxes is therefore poor. In addition, a strong density stratification effectively inhibits vertical mixing. As a result, permanent anoxia exists within 87% of its volume, making the Black Sea the largest anoxic basin of the entire World Ocean. Its surface area is five times smaller than its catchment basin covering parts of the neighboring European and Asian continents where human activities create loads destined for this basin.

About 162 million people live in the catchment area of the Black Sea Basin.

Among the various basins of the World Ocean, the environmental degradation in the Black Sea is the most severe. In a recent study by the Intergovernmental Oceanographic Commission (IOC) examining the health of twelve marine areas (Caribbean, North Sea, West African coast, Baltic Sea, Northern FSU, Mediterranean, Red Sea, the Gulf, Asian Seas, Black Sea, Oligotrophic Gyre and the Great Lakes) with respect to various contaminants, the Black Sea received the poorest marks. The most predominant anthropogenic impact is the severe eutrophication experienced in the surface layers. Regarding marine pollution, the Black Sea thus deserves increased vigilance and effective environmental management.

The environmental crisis in the Black Sea resulting from anthropogenic forcing, and accompanied by natural variability and climatic changes, is manifested by dramatic changes in its ecosystem and resources. The fishery yields have declined dramatically with 80% reduction in total catch in the last few years, and only six out of the 26 species of commercially valuable fish of the 1960's remaining in exploitable quantities. Frequent hypoxia and occasional anoxia have resulted from eutrophication, and have led to nearly complete decline of benthos over broad regions of the shelf. On the Romanian coast alone, a single event of anoxia in 1991 eliminated an estimated 50% of the remaining benthic fish. Decreased light penetration have led to 95% loss in the harvest area of the commercially valuable shallow water algae Phyllophora. Irrecoverable losses of some significant deltaic wetlands and their habitats have taken place. Harmful algal blooms (red tides) are frequently observed.

Changes in the species composition and community structure of plankton, and a loss of diversity in phytoplankton have taken place. The basin's food web has been affected significantly by the rapid influx and spread of predators, especially the ctenophore *mnemiopsis leidyi*. Heavy metals, pesticides, and hydrocarbons mostly originating from terrestrial inputs (notably from the Danube in alarmingly high amounts: 60,000t of total phosphorus, 340,000t of total inorganic nitrogen, 1000t of chromium, 900t of copper, 60t of mercury, 4500t of lead, 50000t of oil) have led to chemical and microbial pollution, affecting public health and tourism industry (annual losses: 400 MUSD).

The events in the Black Sea could be nature's warning for other regions of the world. Knowledge gained from the Black Sea could therefore benefit the other regions of the world ocean.

The Black Sea is a natural test arena for coupled interdisciplinary models developed for understanding oceanographic phenomena common to other areas of the World Ocean. It is an ideal "laboratory" basin to study the effects of anthropogenic forcing, synoptic and climatic variability on non-equilibrium ecosystems.

Last, but not the least; significant efforts are needed from the countries of the Black Sea region to address the call from United Nations Conference On Environment and Development and the Convention on Biodiversity, stressing the importance of a scientific basis for decision-making, and establishment of observation and data basemanagement systems for sources, types, amounts and effects of marine pollutants.

II. Existing Activities.

Various research and management programs have been developed by the riparian states and by international organizations to address some of the issues facing the Black Sea.

The Black Sea Environmental Program is funded by the Global Environmental Facility (GEF) with additional funds from CEC's PHARE and TACIS programs and bilateral contributions from Canada, The Netherlands, Switzerland and France. The major objectives of the program are: a) the strengthening and creation of regional capabilities for managing the Black Sea Ecosystem, b) the development and implementation of policy and legal framework for the assessment, control and prevention of pollution and maintenance and enhancement of biodiversity and c) facilitation of the preparation of sound environmental investments.

The Environmental Program for the Danube River Basin is another effort supported by GEF, with an objective of strengthening the environmental management of the catchment area.

The EROS 2000 (European River Ocean System) program of European Union focuses on the Northwestern Black Sea. Its major objective is the development of an integrated approach to address the problems of eutrophication, contaminants, particle transfer, sedimentation and biogas production, a related task being the utilization of interdisciplinary models for the coupled ocean river systems aiming for the prediction of the coastal ecosystems' response to natural and man made changes in land use and hydraulic management.

The project entitled "Modeling As A Management Tool For The Black Sea: A Regional Program Of Multi-institutional Cooperation" (TU-BLACK SEA) is the first highly significant endeavor of NATO, through its Science for Stability Program, to establish scientific collaboration with the central and eastern European countries. This multi institutional activity will continue till 1997.

The major objectives of the TU-BLACK SEA Project are a) to establish a 2 common database management system in all Black Sea countries, for environmental and oceanographic data pertinent to the goals of the program, b) to provide cross-training and unifying scientific equipment and to carry out intensive and extensive joint in-situ observations as well as monitoring through satellite imagery so as to assist in the development of appropriate infrastructure and capabilities for future research and monitoring activities, and c) to develop interdisciplinary community models for the dynamics of the lower trophic levels of the biological community as affected by anthropogenic changes and physical processes.

The Cooperative Marine Science Program for the Black Sea (CoMSBlack) is an international research program for the scientific study of the Black Sea and is sponsored by IOC. The primary purpose of CoMSBlack is the establishment of a scientific basis for the effective and integrated management of the Black Sea, including environmental preservation, protection and optimum utilization.

The IOC assembly established a Black Sea Regional Program in 1995 to promote, develop and co-ordinate the regional joint marine sciences and services programs at an intergovernmental level, taking into account the existing programs carried out by international institutions and organizations.

Other International organizations such as The International Atomic Energy Agency, the Food and Agricultural Organization, the World Health Organization and the International Maritime Organization also support specific programs in ocean research and fates of radioactive substances.

BASIS FOR THE PROPOSED PROJECT.

The present activities concerned with the degradation of the Black Sea marine environment are time-limited, in that most of them are expected to terminate by the year 1998. In particular, they are not fully designed for the purpose of providing, beyond their scheduled completion dates, predictive ecosystem and environmental models with forecasting capabilities that utilize long-term, real-or-near-real-time systematic observations. The long lead times necessary for the implementation of an operational ocean observing and forecasting system in the period following the existing projects requires its definition and planning now. This task will possess many critical challenges of modern times in organization, scientific knowledge, technology, and financial resources.

The following points are worthy of a note in planning beyond the present activities and research programs in the Black Sea.

Solutions to environmental problems are costly, and costs will increase exponentially as environmental quality declines further. The sooner we are able to adequately predict future changes in our environment, the sooner we can begin to address options and funding requirements for solutions. Potential effects of long term natural variability and climate change aggravate current environmental problems and add another dimension to their complexity, uncertainties existing with regard to the causes, rate and timing of various types of variability.

We cannot move forward in predicting the oceans' response to various forms of forcing without monitoring the ocean on a long-term basis through observation systems. Indeed, model developments needed to reduce environmental threats have reached a plateau; more complete and more accurate data sets are of critical importance, and such are not presently available in the Black Sea. In this respect, it is comforting to observe, for the first time in its history, that sufficient technology is available for obtaining systematic ocean observations, and for processing and interpreting the large volumes of data they will produce.

Having continuous observations systems in place is a prerequisite for intelligently planning corrective or rehabilitative actions dealing with undesirable manifestations of anthropogenic and natural forcings. It is worth noting in this regard that public perceptions of risk are only eased when governments are seen to be keeping a close continuous watch on the marine environment and forecasting for future.

Models can be used to enhance the information derived from the observation network by feeding back information into the observing system, either to assist in its design or to control its operation. Alternatively, observations can be used to validate/verify models or to improve, through data assimilation, their performance.

The long-term systematic design of observation systems and models with predictive capabilities therefore involves careful consideration of the way data and models can be combined. Observations or modelling alone can not advance our scientific understanding of the various ocean processes. Our ability to skilfully merge the two approaches is therefore of crucial importance.

PURPOSE AND OBJECTIVES.

The overall goal of the proposed project is to contribute to the economic and environmental well being and stability of the Black Sea region in the areas of marine environmental risk / threat assessment and prioritization by providing the necessary recommendations for action.

With bearing on the marine environment of the Black Sea, the primary objectives of the proposed project are: to identify and critically overview all of the presently existing NATO (SfS, CCMS, CNAD-SWG12, Defense Research Group) and other research activities (UN, EU etc) within a framework with integrated emphasis placed on modeling, observations, prediction-forecasting and implementation-action planning aspects of these programs, to provide recommendations and a science plan for the implementation of a long-term operational ocean observing and forecasting program for the Black Sea in the period following the existing projects.

WORKPLAN.

Three working groups will be formed with the participating experts. These groups will work on parallel running but highly coupled tracks involving modeling/prediction-forecasting, observation systems and implementation-action plan aspects of the project. Three plenary meetings of the groups are envisaged.

ESTIMATED DURATION.

The project will officially start in July 1996 and be completed in September 1997, the duration of the work being sixteen months.

PROJECT DIRECTORS : Prof. Umit Unluata Director, Middle East Technical University Institute of Marine Sciences POB 28, Erdemli, Icel 33731 Turkey Tel : (324) 521-2150 Fax : (324) 521-2327 e.mail: unluata@deniz.ims.metu.edu.tr Mr. Gary D. VEST Princial Assistant Deputy under Secretary of Defense (Environmental Security) Department of Defense 3400 Defense Pentagon Room 3E792 Washington, DC 20301-3400 U.S.A.

Tel: (703) 697 1013 227 1013 Fax: (703) 693 7011 e-mail: gvest@acq.osd.mil **A LIST OF EXPERTS WITH INTEREST IN THE PROJECT.**

Dr. Snejana MONCHEVA Institute of Oceanology P.O. Box 152, 9000 Varna BULGARIA Phone: +359 52 77 63 55 Fax : +359 52 43 50 15 or 77 42 56 Telex: +865 77237 BAN IO BG Prof. Emil STANEV Meteorology and Geophysics Dept.

Physical Faculty, University of Sofia 5, J.Bourchier Street 1126 Sofia BULGARIA Phone: (+359 2) 6 25 61 (ext.289) Fax : (+359 2) 46 35 89 Telex: + 865 23296 SUKORBG Dr. Adriana COCIASU Romanian Marine Research Inst.

300, Bd. Mamaia, 8700 Constantza ROMANIA Phone: +40 41 64 32 88 Fax : +40 41 83 12 74 Telex: +864 14418 ircm r Dr. Alexandru BOLOGA Romanian Marine Research Institute Mamaia, 8700 Constantza 300, Bd.

ROMANIA Phone: +40 41 64 32 88 Fax : +40 41 83 12 74 Telex: +864 14418 ircm r Prof. Valery EREMEEV Marine Hydrophysical Institut Kapitanskaya St.2 Sevastopol 335000, UKRAINE Phone: +38 0692 52 07 92 or 52 04 52 Fax: +38 0692 4442 53 Telex 197304

SWSWO SU E-Mail: Ocean@mhi2.sevastopol.ua Dr. Leonid IVANOV Marine Hydrophysical Institue Kapitanskaya St.2 Sevastopol 335000, UKRAINE Phone: +38 0692 52 07 92 or 52 04 52 Fax: +38 0692 4442 53 Telex 197304 SWSWO SU E-Mail:

Ocean@mhi2.sevastopol.ua Dr. Victor MELNIKOV Marine Hydrophysical Institue Kapitanskaya St.2 Sevastopol 335000, UKRAINE Phone: +38 0692 52 07 92 or 52 04 52 Fax: +38 0692 44 42 53 Telex 197304 SWSWO SU E-Mail: Ocean@mhi2.sevastopol.ua

Prof. Viktor ZAIKA Institute of Biology of the Southern Seas Nahimova St. 335000

Sevastopol UKRAINE Phone: +38 0690 52 41 10 or 52 37 05 Fax : +38 0690 59 28 13 Telex: 187 124 IBSS SU Prof. Michael E. Vinogradov P.P. Shirshov Institute of Ocean.

Krasikova, 23 Moscow, RUSSIA Phone: +7 095 124 85 26 Fax : +7 095 124 59 83 Dr. Alexander MIKAELYAN P.P. Shirshov Institute of Oceanology Krasikova, 23 Moscow, RUSSIA Phone: +7 095 124 85 26 Fax : +7 095 124 59 83 E-Mail: mikael@optvest.msk.su Prof. Emin OZSOY Middle East Technical Univ.

Institute of Marine Sciences P.O. Box 28, 33731 Erdemli ICEL-TURKEY Phone : +90 324 5212406 or 5213434 Fax : +90 324 5212327 Telex: 67796 DMS TR E-Mail: Ozsoy@deniz.ims.metu.edu.tr Prof. Temel OGUZ Middle East Technical Univ.

Institute of Marine Sciences P.O. Box 28, 33731 Erdemli ICEL-TURKEY Phone : +90 324 5212406 or 5213434 Fax : +90 324 5212327 Telex: 67796 DMS TR E-Mail: Oguz@deniz.ims.metu.edu.tr Prof. Allan ROBINSON Center for Earth and Planetary Sciences Pierce Hall Harvard Univ.

Cambridge, Massachusetts 02138, USA Phone : +1 617 495 2819 Fax : +1 617 495 5192 E-Mail: Robinson@pacific.harvard.edu Prof. Hugh DUCKLOW Woods Hole Oceanographic Inst.

Department of Chemistry Woods Hole, MA 02543, U.S.A.

Phone: +1 508 4572000 (ext. 3357) Fax : +1 508 4572193 E-Mail: hducklow@cliff.whoi.edu Prof. James MURRAY School of Oceanography WB-10 University of Washington Seattle WA 98195, U.S.A.

Phone : +1 206 543 47 30 Fax : +1 206 685 33 51 E-Mail: jmurray@u.washington.edu Prof. Paola MALANOTTE-RIZZOLI Massachusetts Institute of Tech.

54-1415 Cambridge MA, 02139, U.S.A.

Phone: +1 617 253 24 51 Fax : +1 617 253 44 64 E-Mail: kmreyn@mit.edu

12. The Black Sea “Eutrophication Syndrome”.

http://www.bseanetwork.org/Issue2_2.html

The newly published Black Sea Environmental Series Vol. 10: “The Black Sea Pollution Assessment” gives alarming information on pollution in the sea. It confirms that one of the most significant processes degrading the sea is due to the increased concentration of nitrogen and phosphorus compounds, as a result of agricultural, domestic and industrial sources. The dramatic growth of human population in coastal areas, the “Green Revolution” and the increase of agricultural production through fertilisation and intensive live stock farms since the 1960s, the conversion of forests and wetlands into fields and urban areas and the release of nitrogen oxides in the atmosphere, all contribute to the problem. Eutrophication (a phenomenon caused by over-fertilisation) has developed the problem of low oxygen that in its turn has changed the structure of the Black Sea ecosystem that lead to decrease of biodiversity and reduction in the animal populations.

The nitrogen and phosphorus compounds called NUTRIENTS enter the Black Sea from the 17 countries in its drainage basin, mainly through rivers (the three largest rivers are the Danube, Dniepr and Dniestr). The estimations show that about 30 % of the total amount of nutrients originate from the other 11 non-coastal countries and the remaining 70 % - from the six riparian countries.

The largest inputs of nutrients originate from Romania; the second from Ukraine, the next in this order are Bulgaria, Russia, Turkey and Georgia. The most part of Romanian, Ukrainian, Russian and Turkish input flow into the sea from riverine sources, while Bulgarian input comes mainly from industrial sources. Ukraine and Turkey have comparatively high input

from domestic sources also – the waste from a total of almost 6,000,000 people flows directly into the sea and from the rest 10,385,000 people from the coastal areas goes into sewerage systems that discharge microbiological contaminants even after treatment.

All these data show that NUTRIENTS REDUCTION in the Black Sea is a very important step for improving the marine environment though it is only a part of a more complex ecological, economical and engineering remedial actions.

13. Better days for the Black Sea.

<http://europa.eu.int/comm/research/rtdinfosup/en/sea4.htm>

The coasts around the Black Sea have supported human settlements for thousands of years. For thousands of years different civilisations have depended on the rich diversity of plant and animal life in the sea and on the fertile soils on its coasts. The human population has increased steadily during that time but it is only in the last 40 years that the Black Sea has become unable to cope with our demands on it. Urban and industrial development has poured increasing amounts of waste into the rivers leading into the Black Sea and into the seawater itself. By the early 1990s the Black Sea was in the grip of an extreme environmental crisis. Nitrogen, phosphorus and pesticides, added to agricultural land, were present at extremely high concentrations. These excess nutrients were causing massive blooms of micro-organisms. Heavy metals were building up as a result of unrestricted industrial output in eastern and central European countries and oil pollution and pesticide contamination was at an all time high. The combined effect of this mass off-loading had a devastating effect on ecosystems in the area. The fishing industry collapsed completely: fish populations were unable to survive the great change in conditions and this, combined with overfishing, reduced their numbers to practically zero. A species of jellyfish, introduced into the area accidentally, soon multiplied to fill the ecological niche that was left.

Frequent outbreaks of serious water-borne diseases such as cholera and hepatitis A occurred in coastal areas and there were numerous hot spots of very high levels of heavy-metal contamination - so high that investigators checked their instruments for faults when they first saw the readings. When political events in central and eastern Europe led to economic collapse this proved to be a turning point for the Black Sea. A new spirit of co-operation developed in the months that followed and scientists from the European Union were allowed to see the extent of the environmental tragedy for the first time in 1993. All agreed that everything possible should be done to return the Black Sea to its former glory.

Coping with such an enormous disaster is not easy, but progress is being made. Scientists from EROS, one of the major European projects dedicated to the task, began by studying exactly what had happened to the ecosystem whilst monitoring what was still happening. As it turns out, this was probably the very best course of action because the latest results from EROS show that the Black Sea is showing a great capacity to recover naturally. When results taken in Spring 1997 were compared to those from the 1995 EROS cruise, there were some very positive signs that the ecosystem was regenerating. Oxygen concentrations in the water at the upper levels had improved considerably. Some species of plankton and invertebrates, which were thought to have become extinct, were again common. Jellyfish numbers had stabilised while the number of anchovy eggs and larvae had increased. Now, on the solid basis of sound scientific data, we are taking more steps to help the Black Sea.

For example, governments are working together to ensure that, by the end of 2000, all Black Sea discharges will be regulated through national licensing systems.

A sea under stress: Waste from 17 countries drains into the waters of the Black Sea, Almost two thirds of the nitrogen and phosphorus in the seawater comes in from the Danube basin,

Over 10 million people are connected to sewage systems in the Black Sea Coastal region, 111 000 tons of oil enters the Black Sea each year from transport of oil through the Danube.

14. Regional and global ecological problems.

Ecological conditions of the Black Sea and Sea of Azov.

Recent years have seen a slightly improved environmental situation in the region of the Azov and Black Seas with a sound trend towards stabilization.

Monitoring data show that during the last years the content of biogenous substances in water has stabilized at a certain point which is far below the permissible levels for ammonia nitrogen, nitrates, nitrites and phosphates. This is closely related to a considerably reduced application of mineral fertilizers and pesticides to the arable land, which has brought about a reduction of the biogenous and polluting matters washing out from the catchment basins of the major rivers.

The main polluting components of the sea environment are petroleum products. A constant level of the petroleum content in the sea water is caused by the operations of industrial enterprises, ports, discharges of waste during bunkering, and by sewage discharged by municipal services into the rivers flowing into the sea, etc.

In accordance with monitoring results obtained by the State Inspection for protection of the Black Sea, and data from research expeditions of the Ukrainian Research Centre of Marine Ecology, the content of petroleum products in the open parts of the Black Sea surface layers generally does not reach the permissible level (0.05 mg/l). The coastal water area of Greater Yalta is the cleanest with a presence of petroleum products in the samples of 0.02 mg/l.

Many ports of Ukraine experience a slightly increased concentration of petroleum products. Thus, water samples taken in many points around the port area of Odesa, Illitchivsk and Kerch in many cases show a content of petroleum products reaching the permissible pollution level or even exceeding it by as much as 50%.

In general, the monitored coastal regions in 1998 display a trend of stabilization of petroleum product pollution on a certain level below the permissible level with a slight increase in the Kerch area.

Petroleum product content (mg/l) in sea water samples from the major regions of the Black Sea.

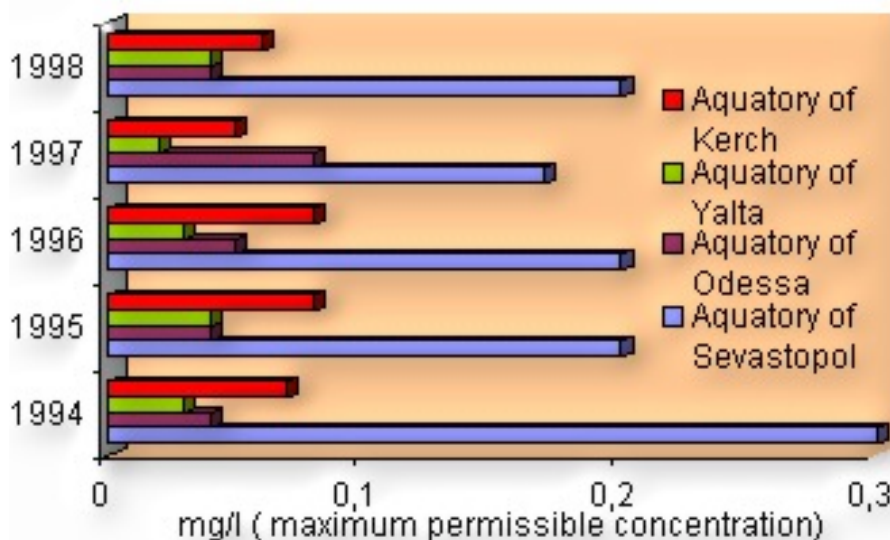

In the last few years the most ecologically dangerous zone of Ukraine in terms of sea water pollution with petroleum products has been the Sevastopol bays. The petroleum product content by far exceed the permissible level of contamination in the bays, mostly as a result of

sea water pollution by the Black Sea Fleet, which stems from improper handling of petroleum products in the bays and discharge of petroleum-containing sewage from ships and coast installations. Samples taken during the last years in the bays of Pivdenna, Kamishova, Golandiya, Karantinna and Pivnichna display a content of polluting petroleum agents in the surface layers of the sea permanently exceeding the maximum permissible level by three to ten times.

In the surface layers of the sea water in the ports, the iron concentration has stabilized on the level of 1996, which is close to the maximum permissible level.

The pollution of the Black Sea areas by synthetic surfactants (surface active substances) remains low, and is generally below the permissible level. However, in areas of municipal sewage discharge the synthetic surfactant concentration in many cases is slightly higher.

In many cities the municipal sewerage systems are in critical condition, which causes frequent accidents with release of large amounts of unpurified sewage into the coastal waters. In the context of the large pressure imposed on the ecological system these discharges lead to a sharp drop in the oxygen concentration in the water areas, causing suffocation of local fish.

During recent years no beaches have been closed due to excessive sea water pollution by chemical agents, however, in several instances beaches have been closed in Odesa, Eupatoria and Sevastopol by the Ministry of Health Care of Ukraine in consequence of epidemiological contamination.

The constant concentration of biogenous substances in the coastal waters below the maximum permissible level of pollution positively affects the ecological situation in the entire ecosystem of the open sea areas. Another positive factor is the absence during the last few years of the phenomenon of algal blooms in the coastal waters, which can be observed only with high concentrations of biogenous substances.

More detailed monitoring of the state of the sea water and bottom deposits has been conducted during expeditions examining the north-western part of the Black Sea launched by the Ukrainian Research Centre of Marine Ecology in 1998 in the open sea and coastal zone. The open sea exploration was performed onboard the scientific ship "Volodymir Parshin" (in November) and the coastal waters examination was launched with the use of the expedition vessel "Yug" in June-September.

Concentrations of organic carbon as an indicator of the general content of organic substances in the sea water generally lies within a range of 0.5 to 3 mg/l. A high concentration of organic carbon, 3.5 mg/l, was observed in a zone in Odesa between the sea water and the Danube River water. The highest concentration of organic carbon, 5.7 mg/l, was detected in the centre of the north-western part of the sea.

The level of pollution of sea water by petroleum carbohydrates in the major part of the north-western zone of the sea and along the Crimean coast does not exceed the maximum permissible concentration and is within the limits of 0.03 to 0.04 mg/l. In some areas the petroleum product concentration exceeds the maximum by two to three times, namely in the Danube estuary, by the entrance to the Karantinna Bay in the port of Sevastopol, and further into the open sea. The maximum concentration of petroleum products, 0.22 mg/l (4.4 times higher than the maximum permissible level), was registered in an area of the Danube River estuary.

Suspended matters are more or less evenly distributed over the dominating part of the Black Sea water area, and their concentration on the average lies within a range of 1 to 3 mg/l. The situation is much more deteriorated in areas close to the river estuaries. Thus, the areas adjacent to the Dniester liman show a concentration of suspended substances as high as 20 mg/l, and in an area by the Danube estuary the content reaches its maximum of 40 to 60 mg/l.

Detergents concentration in the sea water of the open areas of the Black Sea in 1998 was insignificant with just 20% of the maximum permissible level.

The average concentration of phenols in the open sea areas was at least ten times as high as the maximum permissible level (1 mg/l), and in the zones adjacent to the estuaries of the Dniester and Danube rivers this ratio reached a value of 30 to 35 mg/l.

The level of contamination of the sea water with cadmium, lead, zinc, brass, nickel chromium and mercury was below the official maximum permissible level.

The concentrations of chlorine organic pesticides and chlorinated bi-phenyls, which are hazardous to sea fish resources, were also generally negligible. The concentration of chlorine organic pesticides varied in different areas from 0 to 5 ng/l; the concentration of chlorinated bi-phenyls was somewhat higher and reached values of 1 to 30 ng/l. Moreover, the maximum concentration was reported in the areas of the Danube River estuary. It must be mentioned that according to the "Standing rules of sea water protection" a presence of chlorinated carbohydrates in the sea water is not acceptable.

A scientific analysis of the 1998 data obtained from expedition and lab examinations, proves that in keeping with the "Classification of the seabed soils by the degree of their pollution for the Azov-Black Sea Basin within the boundaries of Ukraine", the bottom deposits of a major part of the Black Sea are generally characterized as conditionally clean or moderately polluted soils (class I and II). Only in some areas of the sea are there spots where the quality of the bottom deposits does not match the ecological requirements, and the level of seabed soil pollution brings them to the category of heavily polluted soil (class III). This predominantly concerns the port water areas, especially the ports of Odesa and Sevastopol, areas of sewage discharge into the sea, and some spots in a zone by the Danube river estuary.

Thus, the maximum level of bottom deposits pollution by petroleum products (more than 450 mg/l) has been registered at the entrance to the Karantinnaya Bay in the port of Sevastopol and at the stations in the Danube River estuary zone. Petroleum product concentrations of more than 300 mg/l (Classification class III category) are reported also in bottom deposits close to the Odesa water biological purification station "Pivdenna" and in the area of the prospective dumping in the north-western part of the Black Sea. The same areas, together with the sewage discharge point of the city of Balaklava, also show increased concentrations of aromatic hydrocarbons and 3,4-benzopyrene, which run as high as 50-340 mg/kg and 17-23 mcg/kg, respectively.

Concentrations of toxic metals in the bottom deposits of the Black Sea are at a level far below maximum and thus do not raise concern. Only some regions demonstrate an increased concentration of mercury. This concerns Odesa Region at the points of sewage discharge and in some local port areas. A more serious situation has developed in the area of the Danube River estuary, where two out of eight ecological monitoring stations in 1998 reported a mercury concentration in the bottom deposits of more than 0.3 mg/kg with the maximum value reaching 0.413 mg/kg, which characterize them as areas heavily polluted with mercury (class III). The pollution levels of bottom deposits of lead, zinc and brass are within the limits of class II pollution, even in the "hot spots" of the Black Sea, and a major part of the water area has a level of bottom deposits pollution by the above metals which characterizes the soils as naturally clean or conditionally clean.

The aggravated concentration of the pesticide DDT and its metabolites (DDD and DDE) reaches a level of 2.5 mcg/kg.

The level of Black Sea bottom deposits pollution by the above group of pesticides remains high. The aggravated concentration of DDT and its metabolites ranges from 2.0 to 150 mcg/kg. Levels exceeding the maximum permissible concentration tenfold were reported in 1998 in the following areas: points of sewage discharge in the town of Odesa, Karantinnaya and Kamishova Bays of Sevastopol, the area of prospective dumping in the north-western part of the Black Sea, and the Danube River estuary. The maximum concentration of DDT in the bottom deposits of the Danube River estuary runs as high as 54.2 mcg/l, and together with its

metabolites the pollution level exceeds 150 mcg/l. In other areas of the Black Sea the concentration of these pesticides is negligible and does not exceed the maximum permissible level. Relatively clean from the above agents are the areas of the western coast of Crimea Peninsula, the central region of the north-western part of the Black Sea and the water area by the Dnieper-Buzky liman.

Judging by the chemical pollution level of the Black Sea, the ecological situation in the region in 1998 is considered to be satisfactory with a trend towards a slight improvement as compared with the previous period.

The problems of the Black Sea need close attention and call for a system approach. The strategic directions of sea environment protection and regeneration of its resources in Ukraine will be laid down in the National Programme of Protection and Rehabilitation of the Black Sea and Sea of Azov, which is now drafted by the Ministry of Environmental Protection and Nuclear Safety of Ukraine with the participation of interested ministries and agencies and scientific and public bodies. The Programme comprises measures to reduce the polluted sewage and waste discharge into the seas, preserve their biological resources, regenerate biological diversity, and provide for sustainable nature management in sea and coastal waters. However, the scale and complexity of the problems of degradation of the Black Sea and Sea of Azov ecological systems far extend the boundaries of the individual coastal countries. Ukraine is putting in a lot of efforts to ensure efficient international cooperation on the preservation of the sea environment.

The major international document, which lays down the framework for joint regional principles, is the Convention on Protection of the Black Sea Against Pollution. Ukraine signed the Convention in 1992 and ratified it in 1994. The main objective of the Convention is the establishment of favourable conditions for joining efforts to protect the Black Sea and Sea of Azov environment and their resources, taking into account economic, social and medical aspects of its pollution. The Convention sets out prioritized measures concerning prevention, reduction and supervision of sea pollution created by sea and land activities, as well as ways of cooperation in cases of emergency. It also states that the parties will cooperate in the research and development of the national law to better evaluate ecological losses and determine responsibilities. The integral part of the Convention are the Protocols on reducing sea pollution from the sources located on land, prohibition of the creation of graveyards on the seabed and pollution with petroleum products and other hazardous substances, which turns the Convention into the practical guide of regional environmental management.

The Ministerial Declaration on the protection of the Black Sea (Odesa, 1993) lays down the political framework for implementation of the Convention. It stems from the Rio Declaration and calls for immediate, balanced and continuous actions at all levels aimed at the protection and regeneration of the sea environment and provision for a stable development of the Black Sea.

The Odesa Declaration has become the basis for the International Programme of Environmental Management and Protection of the Black Sea and for drafting the Strategic Action Plan, which was signed in 1996.

Today the joint activities within the framework of international cooperation encompass the development of balanced regional criteria for environmental quality, coordination of the national programmes for reduction of discharges of hazardous substances and biogenes, and the implementation of a balanced system of sea water monitoring.

The Black Sea economic cooperation, which was initiated in 1992 as a process of comprehensive corroboration, has now been transformed into a regional economic organization. Ukraine took part in the work of all working groups, including the group for environmental protection. This working group mainly deals with the environmental problems of the Black Sea. During its last meeting (Sofia, 14-15 September 1998) the working group

approved a decision on the harmonization of environmental monitoring systems. The Black Sea economic cooperation agency supports the foundation of the Black Sea ecological fund and implementation of a joint system of state monitoring of the ports of the region.

Ukraine is a party to the Convention for the Prevention of Pollution from Ships (MARPOL 73/78, renamed in 1999 as MKUB), which designates the Black Sea and Sea of Azov as a "special region".

Waste coming to the Black Sea from the Danube River determines the condition of the regional sea environment. Ukraine takes part in the Black Sea and Danube ecological programmes and makes a great contribution in the implementation of the consecutive regional approach. A joint Black Sea-Danube Working Group has been created to determine the required degree of decrease of biogenes concentration necessary to improve the sea ecological system.

15. L'environnement en europe: extrait de la deuxième évaluation.

Eaux intérieures Milieu marin et littoral

Source : Agence européenne pour l'environnement

Kongens Nytorv 6 DK - 1050 Copenhague K Danemark Tel : +45 33 36 71 00

Fax: +45.33.36.71.99 E-mail: eea@eea.eu.int Internet: www.eea.eu.int Milieu marin et littoral.

Les mers les plus menacées sont la mer du Nord (surpêche, concentration élevée de nutriments et de polluants), les mers ibériques (la partie de l'Atlantique située le long du plateau de l'Atlantique Est, comprenant le Golfe de Gascogne : surpêche, métaux lourds), la mer Méditerranée (concentration élevée de nutriments au niveau local, haute pression sur les côtes, surpêche), la mer Noire (surpêche, augmentation rapide de la concentration de nutriments) et la mer Baltique (concentrations élevées de nutriments, polluants, surpêche).

Résultant principalement des excédents de nutriments dans l'agriculture, l'eutrophisation est une source de préoccupation majeure dans certaines parties de nombreuses mers européennes. Les concentrations de nutriments sont généralement au même niveau qu'au début des années 1990. Les augmentations de rejets d'azote et les concentrations résultantes dans l'eau de mer de certaines côtes occidentales d'Europe semblent être liées aux précipitations élevées et inondations qui ont été enregistrées entre 1994 et 1996. Dans la plupart des autres mers, aucune tendance claire concernant les concentrations de nutriments n'a pu être identifiée. Les concentrations de nutriments dans la mer Noire, provenant principalement du bassin du Danube, ont néanmoins décuplé entre 1960 et 1992.

La contamination des sédiments et des biotes par des produits chimiques d'origine anthropique semble être courante dans pratiquement l'ensemble des mers européennes. Seules des données limitées étaient disponibles, couvrant principalement l'Europe occidentale et du nord-ouest. Des concentrations élevées (supérieures à la teneur naturelle) de métaux lourds et de PCB ont été constatées dans le poisson et les sédiments, avec des niveaux élevés à proximité des sources ponctuelles d'émission. La bioaccumulation de ces substances peut représenter une menace pour les écosystèmes et la santé (comme décrit dans la section sur les produits chimiques).

La situation globale de la pollution pétrolière est extrêmement fragmentaire, et aucune évaluation fiable de l'évolution générale ne peut être réalisée. La principale source est terrestre, atteignant les mers par les rivières. Bien que le nombre annuel de marées noires diminue, des déversements réduits, ou parfois importants, dans les zones à forte circulation de navires entraînent d'importants dommages locaux, principalement la couverture des plages et

des oiseaux marins, et des obstacles à la pêche de poissons et de crustacés et coquillages. Il n'existe toutefois aucune preuve de dommages irrévocables aux écosystèmes marins, qu'il s'agisse de grandes marées noires ou de sources chroniques de pétrole.

De nombreuses mers continuent de faire l'objet d'une surpêche, avec des problèmes particulièrement sérieux dans la mer d'Islande, la mer du Nord, les mers ibériques, la Méditerranée et la mer Noire. Il existe une surcapacité critique de la flotte de pêche, et une réduction de 40 % de la capacité serait nécessaire pour égaler les ressources de poissons disponibles.

16. Publications.

<http://sfp1.ims.metu.edu.tr/TU-BlackSea/publications.htm>

1995

- ANNINSKY, B. E. Seasonal dynamics of chemical composition of organic matter in ctenophore *Mnemiopsis leidyi* in Black Sea. *Okeanologiya*, 35, No.3, (1995): 426-430. (in Russian)
- FINENKO, G. A., G. I. ABOLMASOVA, and Z. A. ROMANOVA Feeding, oxygen consumption and growth of ctenophora *Mnemiopsis mccradyi* in relation to food concentration. *Biologiya Morya*, 21, No.5, (1995): 315-320. (in Russian)
- KUBILAY, N., S. YEMENICIOGLU and C. SAYDAM Airborne material collections and their chemical compositions over the Black Sea. *Marine Pollution Bulletin*, 30(7), (1995): 475-483.
- OGUZ, T., P. MALANOTTE- RIZZOLI, D. AUBREY Wind and thermohaline circulation of the Black Sea driven by yearly mean climatological forcing. *Journal of Geophysical Research*, 100(C4), (1995): 6845-6863.
- OZSOY, E., S. BESIKTEPE Sources of double diffusive convection and impacts on mixing in the Black Sea, (peer reviewed paper). in, *Double-Diffusive Convection*, A. Brandt and H. J. S. Fernando (eds.), *Geophysical Monograph 94*, American Geophysical Union, (1995), pp.261-274.
- OZSOY, E., M. A. LATIF, S. TUGRUL and U. UNLUATA Exchanges with the Mediterranean, fluxes and boundary mixing processes in the Black Sea. *Bulletin de l'Institut Oceanographique*, Monaco, No. Special 15, *CIESM Science Series No.1*, (1995): 1-25.
- POLAT, C., S. TUGRUL Nutrient and organic carbon exchanges between the Black and Marmara Seas through the Bosphorus Strait. *Continental Shelf Research*, 15(9), (1995): 1115-1132.
- SENICHKINA, L. G. Volumetric characteristics of oval and conical cells of phytoplankton. *Gidrobiologicheskyy Zhurnal*, Kiev, Ukraine, 31, No.2, (1995): 103-108. (in Russian)
- SHEMSHURA V. E., Z. Z. FINENKO, Z. P. BURLAKOVA, L. V. EREMEEVA Mathematical simulation of the bio-optical state of water in application to the passive probing problem. *Physical Oceanography*. VSP International Publishers. 6, No 6, (1995): 421-434.
- STOLBOV, A. YA, E. N. STAVITSKAYA and G. E. SHULMAN Oxygen consumption and nitrogen excretion in Black sea fishes of different ecological specialization at hypoxic regimes. *Gidrobiologicheskyy Zhurnal*, 31, No.1, (1995): 73-78. (in Russian) TUGRUL, S. and C. POLAT Quantitative comparison of the influxes of nutrients and organic carbon into the Sea of Marmara both from anthropogenic inputs and from the Black Sea. *Water Science and Technology*, 32(2), (1995): 115-121.

- TUGRUL, S., C. POLAT, O. BASTURK, E. HATIPOGLU, A. YILMAZ, S. YEMENICIOGLU, C. SAYDAM, and I. SALIHOGLU Chemical properties of the two-layer flow regimes in the Turkish Straits. *TR. Journal of Marine Sciences*, 1(2/3): 81-94, 1995.
- UYSAL, Z. and H. I. SUR Net phytoplankton discriminating patches in winter in southern Black Sea coast in winter 1990. *Oceanologica Acta*, 18(6), (1995): 639-647.

1996

- BASTURK, O., S. TUGRUL and I. SALIHOGLU Vertical chemistry of the three dynamically different regions of the Black Sea. *TR. Journal of Marine Sciences*, 2(1), (1996): 35-50.
- BELIAEV, V. I., E. E. SOVGA, S. LUBARTSEVA Modelling hydrogen sulfide zone of the Black Sea. *Ecological Modelling*. No.1-3, (1996):.51-59.
- EDIGER, D., and A. YILMAZ Variability of light transparency in physically and biologically different water masses: Turkish Seas. *Fresenius Environmental Bulletin*, 5, (1996): 133-140.
- GEORGIEVA, L. V., L. G. SENICHKINA Phytoplankton of the Black Sea: current situation and the research prospects. *Ecologiya Morya*, 45, (1996): 6-13. (in Russian)
- GORDINA, A. D., T. N. KLIMOVA On the bluefish (*Pomatomus Saltatrix* L.) spawning in the Black Sea. *Marine and Freshwater Research*, Melbourne, Australia, 47, (1996):.315-318.
- MANKOVSKY, V. I., M. V. SOLOV'EV, V. L. VLADIMIROV Variability of the hydrooptical features of the Black Sea (1922-1992). *Oceanology (Okeanologiya)*, 36(3), (1996): 339-345.
- MUTLU, E. Target strength of common jellyfish (*Aurelia aurita*: Scyphozoa): A preliminary experimental study with a dual-beam acoustical system. *ICES Journal of Marine Science*, 53(2), (1996): 309-311.
- OGUZ, T., and P. MALANOTTE-RIZZOLI Seasonal variability of wind and thermohaline driven circulation in the Black Sea. Modelling studies. *Journal of Geophysical Research*, 101(C7), (1996): 16551-16569.
- OGUZ, T., H. DUCKLOW, P. MALANOTTE-RIZZOLI, S. TUGRUL, N. P. NEZLIN, U. UNLUATA Simulation of annual plankton productivity cycle in the Black Sea by a one-dimensional physical-biological model. *Journal of Geophysical Research*, 101(C7), (1996): 16585-16599.
- OZSOY, E., M. A. LATIF, H. I. SUR and Y. GORYACHKIN A review of the exchange flow regime and mixing in the Bosphorus Straits. *Bulletin de l'Institut Oceanographique*, Monaco, No. Special volume 17 on the Dynamics of the Mediterranean Straits. Frederic Briand (ed.), CIESM Science Series No.2, (1996): 187-204.
- POLAT, C., S. TUGRUL Chemical exchange between the Mediterranean and the Black Sea via the Turkish Straits. *Bulletin de l'Institut Oceanographique*, Monaco, No. Special volume 17 on the Dynamics of the Mediterranean Straits. Frederic Briand (ed.), CIESM Science Series No.2, (1996): 167-186.
- SHULMAN, G. E. Physiology-biochemical research of hydrobionts. *Ecologiya Morya*, No.5, (1996): 38-48. (in Russian)
- SUR, H. I., E. OZSOY, Y. P. ILYIN, and U. UNLUATA Coastal/deep ocean interactions in the Black Sea and their ecological/environmental impacts. *Journal of Marine Systems*, 7, (1996): 293-320.
- TANHUA, T., E. FOGELQVIST and O. BASTURK Reduction of volatile halocarbons in anoxic seawater, results from a study in the Black Sea. *Marine Chemistry*, 54(1/2), (1996): 159-170.

1997

- GORDINA, A. D., V. N. NIKOLSKIY, U. NIERMANN, F. BINGEL, A. A. SUBBOTIN New data on the morphological differences of anchovy eggs (*Engraulis encrasicolus* L.) in the Black Sea. *Fishery Bulletin*, 31: (1997), 139-145.
- KRIVOSHEYA, V. G., and O. I. PROKOPOV Studies of northeastern part of the Black sea in the framework of International Projects (R/V Yantar', June 25- July 6, 1996). *Oceanology*, 37(2), (1997): 289-290.
- NERETIN, L. N., T. P. DEMIDOVA, and I. I. VOLKOV Features of spatial variability of a hydrogen sulfide fields in the Black Sea off the Northern Caucasus. *Oceanology*, 37(3), (1997): 332-338.
- OZSOY, E. and U. UNLUATA Oceanography of the Black Sea: A review of some recent results. *Earth Sci. Rev.*, 42(4), (1997): 231-272.
- SUR, H. I. and Y. P. ILYIN Evolution of satellite derived mesoscale thermal patterns in the Black Sea. *Progress in Oceanography*, 39, (1997): 109-151.
- YUNEVA, T. V., L. S. SVETLICHNYI, O. A. YUNEV, L. V. GEORGIEVA, L. G. SENICHKINA Spatial variability of the lipid content in *Calanus euxinus* in relation to the chlorophyll concentration and phytoplankton biomass. *Oceanology*, 37(5), (1997): 672-678.

1998

- BASTURK, O., I. I. VOLKOV, S. GOKMEN, H. GUNGOR, A. S. ROMANOV and E. V. YAKUSHEV International expedition on board R/V Bilim in July 1997 in the Black Sea. *Oceanology*, 38(3), (1998): 429-432
- BESIKTEPE, S., A. E. KIDEYS and M. UNSAL In situ grazing pressure and diel vertical migration of female *Calanus euxinus* in the Black Sea. *Hydrobiologia*, 363 (1998): 323-332.
- NIERMANN, U., F. BINGEL, G. ERGUN, W. GREWE Fluctuation of dominant mesozooplankton species in the Black Sea, North Sea and the Baltic Sea: Is a general trend recognizable? *Turkish Journal of Zoology*, 22, (1998): 63-81.
- YILMAZ, A., S. TUGRUL, C. POLAT, D. EDIGER, Y. COBAN and E. MORKOC On the production, elemental composition (C, N, P) and distribution of photosynthetic organic matter in the southern Black Sea. *Hydrobiologia*, 363, (1998): 141-156.

Papers Accepted for Publications

- IVANOV, L. I., S. BESIKTEPE, E. OZSOY, M. DUMAN, V. DIACONU, E. DEMIROV Recent changes in the Black Sea pycnocline. *Journal of Marine Systems*, (1998).
- OGUZ, T., H. W. DUCKLOW, P. MALANOTTE-RIZZOLI, J. W. MURRAY, E. A. SHUSHKINA, V. I. VEDERNIKOV, U. UNLUATA A physical-biochemical model of plankton productivity and nitrogen cycling in the Black Sea. *Deep Sea Research I*, (1998).
- OGUZ, T., U. UNLUATA, H. DUCKLOW, P. MALANOTTE-RIZZOLI, and J. MURRAY Simulation of the Black Sea pelagic ecosystem structure by vertically-resolved coupled physical-biochemical models. Submitted to *Fisheries Oceanography GLOBEC OSM Special Issue*, (1998).

Papers Submitted for Publication

- IVANOV, L. I., S. BESIKTEPE, E. G. NIKOLAENKO, E. OZSOY, V. DIACONU, E. DEMIROV Volumetric fine structure of the Black Sea Cold Intermediate Layer. Submitted to *Deep Sea Research*, (1998).

- OGUZ, T., and S. BESIKTEPE Observation on the mesoscale variability of the rim current structure and CIW formation and transport in the western Black Sea. Submitted to Deep Sea Research I, (1998).
- RANK, D., E. OZSOY, I. SALIHOGLU Oxygen 18O, deuterium and tritium in the Black Sea and the Sea of Marmara. Submitted to J. Env. Rad., (1998).

Books and Book Chapters

1995

- KONOVALOV, S. M., A. D. GORDINA, L. S. OVEN, A. V. TKACH (eds.) The Modern State of Black Sea Ichthyofauna: Col. Sci. Papers. NAS of the Ukraine. Institute of Biology of Southern Seas. Executive Editor S.M. Konovalov, Sevastopol, 1995, 214p. ISBN 5-7702-1273-X. (in Russian)

1996

- MANKOVSKY V. I., V. L. VLADIMIROV, E. I. AFONIN, M. V. SOLOVEV, A. V. MISHONOV, B. E. ANNINSKIY, L. V. GEORGIEVA, O. A. YUNEV Long-term variability of the Black Sea water transparency and factors determined its strong decrease in the late 1980s early 1990s. - MHI & IBSS, Sevastopol, 1996, 32pp. (in Russian).

1997

- Sensitivity to Change: Black Sea, Baltic Sea and North Sea, E. Ozsoy and A. Mikaelyan (eds.), NATO-ASI Series, The Netherlands, Kluwer Academic Publishers, 1997
- BASTURK, O., S. TUGRUL, S. KONOVALOV and I. SALIHOGLU Variation in the vertical structure of water chemistry within the three hydrodynamically different regions of the Black Sea. in, Sensitivity to Change: Black Sea, Baltic Sea and North Sea, E. Ozsoy and A. Mikaelyan (eds.), NATO-ASI Series, The Netherlands, Kluwer Academic Publishers, 1997, pp.183-196.
- BURLAKOVA, Z. P., L. V. EREMEEVA, S. K. KONOVALOV Particulate organic matter of Black Sea euphotic zone: Seasonal and long-term variation of spatial distribution and composition. in, Sensitivity to Change: Black Sea, Baltic Sea and North Sea, E. Ozsoy and A. Mikaelyan (eds.), NATO-ASI Series, The Netherlands, Kluwer Academic Publishers, 1997, pp.223-238.
- DEMIROV, E., M. A. LATIF, and V. DIACONU Physical processes of surface-deep layers exchange in the Black Sea. in, Sensitivity to Change: Black Sea, Baltic Sea and North Sea, E. Ozsoy and A. Mikaelyan (eds.), NATO-ASI Series, The Netherlands, Kluwer Academic Publishers, 1997. pp. 285-294.
- EREMEEV, V. N., L. I. IVANOV, A. S. SAMODUROV and M. DUMAN Black Sea bottom homogenous layer: A simple model of formation, in, Sensitivity to Change: Black Sea, Baltic Sea and North Sea, E. Ozsoy and A. Mikaelyan (eds.), NATO-ASI Series, The Netherlands, Kluwer Academic Publishers, 1997. pp. 275-283.
- GUCU, A. C. Role of fishing on Black Sea ecosystem. in, Sensitivity to Change: Black Sea, Baltic Sea and North Sea, E. Ozsoy and A. Mikaelyan (eds.), NATO-ASI Series, The Netherlands, Kluwer Academic Publishers, 1997. pp.149-162.
- IVANOV, L. I., S. BESIKTEPE, E. OZSOY The Black Sea cold intermediate layer. in, Sensitivity to Change: Black Sea, Baltic Sea and North Sea, E. Ozsoy and A. Mikaelyan (eds.), NATO-ASI Series, The Netherlands, Kluwer Academic Publishers, 1997. pp. 253-264.
- IVANOV, L. I., S. BESIKTEPE, E. OZSOY Physical oceanography variability in the Black Sea pycnocline. in, Sensitivity to Change: Black Sea, Baltic Sea and North Sea, E.

- Ozsoy and A. Mikaelyan (eds.), NATO-ASI Series, The Netherlands, Kluwer Academic Publishers, 1997. pp.265-274.
- KONOVALOV, S., S. TUGRUL, O. BASTURK and I. SALIHOGLU Spatial isopycnal analysis of the main pycnocline chemistry of the Black Sea: Seasonal and interannual variations. in, *Sensitivity to Change: Black Sea, Baltic Sea and North Sea*, E. Ozsoy and A. Mikaelyan (eds.), NATO-ASI Series, The Netherlands, Kluwer Academic Publishers, 1997. pp.197-210.
 - KONSOULOV, A. and L. KAMBURSKA Sensitivity to anthropogenic factors of the plankton fauna adjacent to Bulgarian coast of the Black Sea. in, *Sensitivity to Change: Black Sea, Baltic Sea and North Sea*, E. Ozsoy and A. Mikaelyan (eds.), NATO-ASI Series, The Netherlands, Kluwer Academic Publishers, 1997. pp. 95-104.
 - KOROTAEV, G. K. Circulation in semi-enclosed seas induced by buoyancy flux through a strait. in, *Sensitivity to Change: Black Sea, Baltic Sea and North Sea*, E. Ozsoy and A. Mikaelyan (eds.), NATO-ASI Series, The Netherlands, Kluwer Academic Publishers, 1997, pp. 395-401.
 - MIKAELYAN, A. S. Long-term variability of phytoplankton communities in open Black Sea in relation to environmental changes. in, *Sensitivity to Change: Black Sea, Baltic Sea and North Sea*, E. Ozsoy and A. Mikaelyan (eds.), NATO-ASI Series, The Netherlands, Kluwer Academic Publishers, 1997, pp.105-116.
 - MONCHEVA, S. and A. KRASSTEV Some aspects of phytoplankton long-term alterations off Black Sea shelf. in, *Sensitivity to Change: Black Sea, Baltic Sea and North Sea*, E. Ozsoy and A. Mikaelyan (eds.), NATO-ASI Series, The Netherlands, Kluwer Academic Publishers, 1997, pp. 79-94.
 - NEZLIN, N. P. Seasonal variation of surface pigment distribution in the Black Sea on CZCS data. in, *Sensitivity to Change: Black Sea, Baltic Sea and North Sea*, E. Ozsoy and A. Mikaelyan (eds.), NATO-ASI Series, The Netherlands, Kluwer Academic Publishers, 1997, pp. 131-138.
 - NIERMANN, U., W. GREVE Distribution and fluctuation of dominant zooplankton species in the southern Black Sea in comparison to the North Sea and Baltic Sea. in, *Sensitivity to Change: Black Sea, Baltic Sea and North Sea*, E. Ozsoy and A. Mikaelyan (eds.), NATO-ASI Series, The Netherlands, Kluwer Academic Publishers, 1997. pp.65-78.
 - OGUZ, T., P. MALANOTTE-RIZZOLI and H. DUCKLOW Towards coupling three dimensional eddy resolving general circulation and biochemical models in the Black Sea. in, *Sensitivity to Change: Black Sea, Baltic Sea and North Sea*, E. Ozsoy and A. Mikaelyan (eds.), NATO-ASI Series, The Netherlands, Kluwer Academic Publishers, 1997, pp.469-486. OZSOY, E. and A. MIKAELYAN (editors) *Sensitivity to Change: Black Sea, Baltic Sea and North Sea*, NATO-ASI Series, (Partnership Sub-series, Environment, 27,) The Netherlands, Kluwer Academic Publishers, 1997, 536pp. (Proceedings of a NATO Advanced Research Workshop, Varna Bulgaria, 14-18 November, 1995).
 - POLONSKY, A., E. VOSKRESENSKAYA, V. BELOKOPYTOV Variability of northwestern Black Sea hydrography and river discharges as part of global ocean-atmosphere fluctuations. in, *Sensitivity to Change: Black Sea, Baltic Sea and North Sea*, E. Ozsoy and A. Mikaelyan (eds.), NATO-ASI Series, The Netherlands, Kluwer Academic Publishers, 1997, pp.11-24
 - SHIGANOVA, T. A. Mnemiopsis Leidy abundance in the Black Sea and its impact on the pelagic community. in, *Sensitivity to Change: Black Sea, Baltic Sea and North Sea*, E. Ozsoy and A. Mikaelyan (eds.), NATO-ASI Series, The Netherlands, Kluwer Academic Publishers, 1997, pp.117-129.

- TRUHKCHEV, D. I. and R. A. IBRAYEV Seasonal variability of the Black Sea climatic circulation. in, *Sensitivity to Change: Black Sea, Baltic Sea and North Sea*, E. Ozsoy and A. Mikaelyan (eds.), NATO-ASI Series, The Netherlands, Kluwer Academic Publishers, 1997, pp.365-374.
- VLADIMIROV, V. L., V. I. MANKOVSKY, M. V. SOLOV'EV and A. V. MISHONOV Seasonal and long-term variability of the Black Sea optical parameters. in, *Sensitivity to Change: Black Sea, Baltic Sea and North Sea*, E. Ozsoy and A. Mikaelyan (eds.), NATO-ASI Series, The Netherlands, Kluwer Academic Publishers, 1997, pp.33-48.
- VOSTOKOV, S. V. Suspended matter as an index of productivity in the western Black Sea (application for productivity and eutrophication control). in, *Sensitivity to Change: Black Sea, Baltic Sea and North Sea*, E. Ozsoy and A. Mikaelyan (eds.), NATO-ASI Series, The Netherlands, Kluwer Academic Publishers, 1997, pp.211-221.
- ZAITSEV, Yu. P., B. G. ALEXANDROV Recent man-made changes in the Black Sea ecosystem. in, *Sensitivity to Change: Black Sea, Baltic Sea and North Sea*, E. Ozsoy and A. Mikaelyan (eds.), NATO-ASI Series, The Netherlands, Kluwer Academic Publishers, 1997, pp.25-31.

1998

- Nato Tu-Black Sea Project: Ecosystem Modelling As A Management Tool For The Black Sea. L. Ivanov And T. OGuz (Eds.), Kluwer Academic Publishers, Netherlands, 1998
- ANNINSKY, B. E., Z. A. ROMANOVA, G. I. ABOLMASOVA, A. C. GUCU, A. E. KIDEYS Ecological and physiological state of the ctenophore *Mnemiopsis leidyi* (Agassiz) in the Black Sea in Autumn 1996. NATO TU-Black Sea Project: Ecosystem Modelling as a Management Tool for the Black Sea. L. Ivanov and T. OGuz (eds.), Kluwer Academic Publishers, Netherlands, 1998. Vol.1, pp. 249-262.
- ARASHKEVICH, E., L. SVETLICHNY, E. GUBAREVA, S. BESIктеPE, A. C. GUCU, A. E. KIDEYS Physiological and ecological studies of *Calanus euxinus* (Hulsemann) from the Black Sea with comments on its life cycle. NATO TU-Black Sea Project: Ecosystem Modelling as a Management Tool for the Black Sea. L. Ivanov and T. OGuz (eds.), Kluwer Academic Publishers, Netherlands, 1998. Vol.1, pp. 351-366.
- BASTURK, O., S. TUGRUL, S. KONOVALOV and I. SALIHOGLU Effects of circulation on the spatial distribution of principal chemical properties and unexpected short and long -term changes in the Black Sea. NATO TU-Black Sea Project: Ecosystem Modelling as a Management Tool for the Black Sea. L. Ivanov and T. OGuz (eds.), Kluwer Academic Publishers, Netherlands, 1998. Vol.1, pp. 39-54.
- BELOKOPYTOV, V. On hydrometeorological conditions of Cold Intermediate Water renewal in the northern part of the Black Sea. NATO TU-Black Sea Project: Ecosystem Modelling as a Management Tool for the Black Sea. L. Ivanov and T. OGuz (eds.), Kluwer Academic Publishers, Netherlands, 1998. Vol.2, pp.47-52.
- COKACAR, T. and E. OZSOY Comparative analysis and modelling for regional ecosystems of the Black Sea. NATO TU-Black Sea Project: Ecosystem Modelling as a Management Tool for the Black Sea. L. Ivanov and T. OGuz (eds.), Kluwer Academic Publishers, Netherlands, 1998. Vol.2, pp. 323-358.
- GOKMEN, S. and O. BASTURK Some remarks on the removal rates of H₂S within the suboxic zone of the different regions of the Black Sea. NATO TU-Black Sea Project: Ecosystem Modelling as a Management Tool for the Black Sea. L. Ivanov and T. OGuz (eds.), Kluwer Academic Publishers, Netherlands, 1998. Vol.1, pp. 65-76.
- GOKMEN, S., A. S. ROMANOV, O. BASTURK, S. KONOVALOV A comparative study of spectrophotometric and iodometric back titration methods for hydrogen sulfide determination in anoxic Black Sea waters. NATO TU-Black Sea Project: Ecosystem

- Modelling as a Management Tool for the Black Sea. L. Ivanov and T. OGuz (eds.), Kluwer Academic Publishers, Netherlands, 1998. Vol.1, pp.55-64.
- GORDINA, A. D., U. NIERMANN, A. E. KIDEYS, A. A. SUBBOTIN, YU. G. ARTYOMOV, F. BINGEL State of summer ichthyoplankton in the Black Sea. NATO TU-Black Sea Project: Ecosystem Modelling as a Management Tool for the Black Sea. L. Ivanov and T. OGuz (eds.), Kluwer Academic Publishers, Netherlands, 1998. Vol.1, pp. 367- GUCU, A. C., T. OGUZ Modeling trophic interrelationships in the Black Sea. NATO TU-Black Sea Project: Ecosystem Modelling as a Management Tool for the Black Sea. L. Ivanov and T. OGuz (eds.), Kluwer Academic Publishers, Netherlands, 1998. Vol.2, pp. 359-372.
 - IBRAYEV, R. A., D., I. TRUKHCHEV Model studies of the seasonal variability of the Black Sea circulation. NATO TU-Black Sea Project: Ecosystem Modelling as a Management Tool for the Black Sea. L. Ivanov and T. OGuz (eds.), Kluwer Academic Publishers, Netherlands, 1998. Vol.2, pp. 179-196.
 - ILYIN, YU. P., S. BESIKTEPE, V. A. IVANOV, H. I. SUR, E. M. LEMESHKO, H. GUNGOR, E. OZSOY Western Black Sea currents by the ship measurements and satellite imagery. NATO TU-Black Sea Project: Ecosystem Modelling as a Management Tool for the Black Sea. L. Ivanov and T. OGuz (eds.), Kluwer Academic Publishers, Netherlands, 1998. Vol.2, pp. 119-130.
 - IVANOV, L. AND T. OGUZ NATO TU-Black Sea Project: Ecosystem Modelling as a Management Tool for the Black Sea. L. Ivanov and T. OGuz (eds.), Kluwer Academic Publishers, Netherlands, 1998. 2 Vols.
 - IVANOV, L. I., S. KONOVALOV, V. BELOKOPYTOV, E. OZSOY Regional peculiarities of physical and chemical responses to changes in external conditions within the Black Sea pycnocline: Cooling phase. NATO TU-Black Sea Project: Ecosystem Modelling as a Management Tool for the Black Sea. L. Ivanov and T. OGuz (eds.), Kluwer Academic Publishers, Netherlands, 1998. Vol.2, pp.53-68.
 - IVANOV, L. I., S. KONOVALOV, V. MELNIKOV, A. MIKAELIAN, O. YUNEV, O. BASTURK, V. BELOKOPYTOV, S. BESIKTEPE, N. BODEANU, A. BOLOGA, A. COCIASU, V. DIAKONU, L. KAMBURSKA, A. KIDEYS, V. MANKOVSKY, S. MONCHEVA, N. NEZLIN, U. NIERMANN, A. PETRANU, N. SHALOVENKOV, E. SHUSHKINA, I. SALIHOGLU, L. SENICHKINA, Z. UYSAL, V. VEDERNIKOV, V. YAKUBENKO, E. YAKUSHEV, A. YILMAZ Physical, chemical and biological data sets of the TU Black Sea Data Base: Description and evaluation. NATO TU-Black Sea Project: Ecosystem Modelling as a Management Tool for the Black Sea. L. Ivanov and T. OGuz (eds.), Kluwer Academic Publishers, Netherlands, 1998. Vol.1, pp.11-38
 - KIDEYS, A. E., A. D. GORDINA, U. NIERMANN, Z. UYSAL, T. A. SHIGANOVA, F. BINGEL Distribution of eggs and larvae of anchovy with respect to ambient conditions in the southern Black Sea during 1993 and 1996. NATO TU-Black Sea Project: Ecosystem Modelling as a Management Tool for the Black Sea. L. Ivanov and T. OGuz (eds.), Kluwer Academic Publishers, Netherlands, 1998. Vol.1, pp. 189-198.
 - KOVALEV, A. V., S. BESIKTEPE, J. ZAGORODNYAYA, A. E. KIDEYS Mediterraneanization of the Black Sea zooplankton is continuing. NATO TU-Black Sea Project: Ecosystem Modelling as a Management Tool for the Black Sea. L. Ivanov and T. OGuz (eds.), Kluwer Academic Publishers, Netherlands, 1998. Vol.1, pp. 199-208.
 - KOVALEV, A. V., A. D. GUBANOVA, A. E. KIDEYS, V. V. MELNIKOV, U. NIERMANN, N. A. OSTROVSKAYA, I. YU. PRUSOVA, V. A. SKRYABIN, Z. UYSAL, J. ZAGORODNYAYA Long-term changes in the biomass and composition of fodder zooplankton in coastal regions of the Black Sea during the Period 1957-1996. NATO TU-Black Sea Project: Ecosystem Modelling as a Management Tool for the Black

- Sea. L. Ivanov and T. OGuz (eds.), Kluwer Academic Publishers, Netherlands, 1998. Vol.1, pp. 209-220.
- KOVALEV, A. V., U. NIEMANN, V. V. MELNIKOVA, V. BELOKOPYTOV, Z. UYSAL, A. E. KIDEYS, M. UNSAL, D. ALTUKHOV Long-term changes in the Black Sea zooplankton: the role of natural and anthropogenic factors. NATO TU-Black Sea Project: Ecosystem Modelling as a Management Tool for the Black Sea. L. Ivanov and T. OGuz (eds.), Kluwer Academic Publishers, Netherlands, 1998. Vol.1, pp. 221-234.
 - KONSULOV, A., L. KAMBURSKA Black Sea zooplankton structural dynamics and variability off the Bulgarian Black Sea coast during 1991 - 1995. NATO TU-Black Sea Project: Ecosystem Modelling as a Management Tool for the Black Sea. L. Ivanov and T. OGuz (eds.), Kluwer Academic Publishers, Netherlands, 1998. Vol.1, pp. 281-292.
 - KRIVENKO, O. V., Z. P. BURLAKOVA, L. V. EREMEEVA. Some aspects of nitrogen biotic cycle in the open western part of the Black Sea. NATO TU-Black Sea Project: Ecosystem Modelling as a Management Tool for the Black Sea. L. Ivanov and T. OGuz (eds.), Kluwer Academic Publishers, Netherlands, 1998. Vol.1, pp. 121-136.
 - KRIVOSHEVA, V. G., F. NYFFELER, V. G. YAKUBENKO, I. M. OVCHINNIKOV, R. D. KOS'YAN, E. A. KONTAR Experimental studies of eddy structure within the Rim Current zone in the north-eastern part of the Black Sea. NATO TU-Black Sea Project: Ecosystem Modelling as a Management Tool for the Black Sea. L. Ivanov and T. OGuz (eds.), Kluwer Academic Publishers, Netherlands, 1998. Vol.2, pp. 131-144.
 - LYUBARTSEVA, S. P., V. G. LYUBARTSEV The model of the Black Sea hydrogen sulfide zone ecosystem. NATO TU-Black Sea Project: Ecosystem Modelling as a Management Tool for the Black Sea. L. Ivanov and T. OGuz (eds.), Kluwer Academic Publishers, Netherlands, 1998. Vol.2, pp. 385-395.
 - MANKOVSKY, V. I., V. L. VLADIMIROV, M. V. SOLOV'EV, S. BESIKTEPE Optical research in the Black Sea in the framework of CoMSBlack & TU Black Sea programs in 1991-95. NATO TU-Black Sea Project: Ecosystem Modelling as a Management Tool for the Black Sea. L. Ivanov and T. OGuz (eds.), Kluwer Academic Publishers, Netherlands, 1998. Vol.2, pp.145-162.
 - MONCHEVA, S., G. SHTEREVA, A. KRASDEV, N. BODEANU, A. E. KIDEYS, S. BAYRAKDAR Vertical distribution of summer phytoplankton in the western Black Sea during 1991-1995 with respect to some environmental factors. NATO TU-Black Sea Project: Ecosystem Modelling as a Management Tool for the Black Sea. L. Ivanov and T. OGuz (eds.), Kluwer Academic Publishers, Netherlands, 1998. Vol.1, pp.327-350.
 - NEZLIN, N. P., V. YU. DYAKONOV Seasonal and interannual variations of surface chlorophyll concentrations in the Black Sea on CZCS data. NATO TU-Black Sea Project: Ecosystem Modelling as a Management Tool for the Black Sea. L. Ivanov and T. OGuz (eds.), Kluwer Academic Publishers, Netherlands, 1998. Vol.1, pp. 137-150.
 - OGUZ, T., L. I. IVANOV, S. BESIKTEPE Circulation and hydrographic characteristics of the Black Sea during July 1992. NATO TU-Black Sea Project: Ecosystem Modelling as a Management Tool for the Black Sea. L. Ivanov and T. OGuz (eds.), Kluwer Academic Publishers, Netherlands, 1998. Vol.2, pp. 69-92.
 - OGUZ, T., S. T. BESIKTEPE, L. I. IVANOV, V. DIACONU On the ADCP derived Rim Current structure, CIW formation and the role of mesoscale eddies on the CIW transport in the Black Sea. NATO TU-Black Sea Project: Ecosystem Modelling as a Management Tool for the Black Sea. L. Ivanov and T. OGuz (eds.), Kluwer Academic Publishers, Netherlands, 1998. Vol.2, pp.93-118.
 - OGUZ, T., H. DUCKLOW, E. A. SHUSKINA, P. MALANOTTE-RIZZOLI, S. TUGRUL, L. P. LEBEDEVA Simulation of the upper layer biochemical structure in the Black Sea. NATO TU-Black Sea Project: Ecosystem Modelling as a Management Tool

- for the Black Sea. L. Ivanov and T. OGuz (eds.), Kluwer Academic Publishers, Netherlands, 1998. Vol.1, Vol.2, pp. 257-300.
- OSTROVSKAYA, N. A., A. D. GUBANOVA, A. E. KIDEYS, V. V. MELNIKOVA, U. NIERMANN, E. V. OSTROVSKY Production and Biomass of *Acartia Clausi* in the Black Sea During Summer Before and After the Mnemiopsis Outburst. NATO TU-Black Sea Project: Ecosystem Modelling as a Management Tool for the Black Sea. L. Ivanov and T. OGuz (eds.), Kluwer Academic Publishers, Netherlands, 1998. Vol.1, pp.163-170.
 - OZSOY, E., M. A. LATIF, S. BESIKTEPE, N. CETIN, M. C. GREGG, V. BELOKOPYTOV, YU. GORYACHKIN, V. DIAKONU The Bosphorus Strait: exchange fluxes, currents and sea level changes. NATO TU-Black Sea Project: Ecosystem Modelling as a Management Tool for the Black Sea. L. Ivanov and T. OGuz (eds.), Kluwer Academic Publishers, Netherlands, 1998. Vol.2, pp.1-28.
 - RACHEV, N. H., E. V. STANEV Rossby modes in semi-enclosed basins. Their relevance to dissipation and mixing in the Black Sea. NATO TU-Black Sea Project: Ecosystem Modelling as a Management Tool for the Black Sea. L. Ivanov and T. OGuz (eds.), Kluwer Academic Publishers, Netherlands, 1998. Vol.2, pp. 163-178.
 - RANK, D., E. OZSOY, I. SALIHOGLU, Z. TOP Isotope measurements in the Black Sea and the Sea of Marmara. NATO TU-Black Sea Project: Ecosystem Modelling as a Management Tool for the Black Sea. L. Ivanov and T. OGuz (eds.), Kluwer Academic Publishers, Netherlands, 1998. Vol.2, pp.29-46.
 - ROZANOV, A. G., L. N. NERETIN, I. I. VOLKOV Redox Nepheloid layer of the Black Sea: Its location, composition and origin.
 - NATO TU-Black Sea Project: Ecosystem Modelling as a Management Tool for the Black Sea. L. Ivanov and T. OGuz (eds.), Kluwer Academic Publishers, Netherlands, 1998. Vol.1, pp. 77-92.
 - SAMODUROV, A. S., and L. I. IVANOV Processes of ventilation of the Black Sea related to water exchange through Bosphorus.
 - NATO TU-Black Sea Project: Ecosystem Modelling as a Management Tool for the Black Sea. L. Ivanov and T. OGuz (eds.), Kluwer Academic Publishers, Netherlands, 1998. Vol.2. pp.221-236.
 - SHALOVENKOV, N. Changing of the benthic communities in the Sevastopol Bay estuary during the last eighty years. NATO TU-Black Sea Project: Ecosystem Modelling as a Management Tool for the Black Sea. L. Ivanov and T. OGuz (eds.), Kluwer Academic Publishers, Netherlands, 1998. Vol.1, pp. 301-310.
 - SHIGANOVA T. A., A. E. KIDEYS, A. G. GUCU, U. NIERMANN, V. S. KHOROSHILOV Changes in species diversity and abundance of the main components of the Black Sea pelagic community during the last decade. NATO TU-Black Sea Project: Ecosystem Modelling as a Management Tool for the Black Sea. L. Ivanov and T. OGuz (eds.), Kluwer Academic Publishers, Netherlands, 1998. Vol.1, pp.171-188.
 - SHULMAN, G. E., T. V. YUNEVA, O. A. YUNEV, L. S. SVETLICHNY, B. E. ANNINSKY, Z. A. ROMANOVA, E. G. ARASHKEVICH, A. E. KIDEYS, F. BINGEL, Z. UYSAL, A. YILMAZ A biochemical approach for the estimation of food provision for heterotrophic organisms of the Black Sea. NATO TU-Black Sea Project: Ecosystem Modelling as a Management Tool for the Black Sea. L. Ivanov and T. OGuz (eds.), Kluwer Academic Publishers, Netherlands, 1998. Vol.1, pp. 263-280.
 - SHUSHKINA, E. A., M. E. VINOGRADOV, L. P. LEBEDEVA, T. OGUZ, N. P. NEZLIN, V. YU. DYAKONOV, L. L. ANOKHINA Studies of structural parameters of planktonic communities of the open part of the Black Sea relevant to ecosystem modeling. NATO TU-Black Sea Project: Ecosystem Modelling as a Management Tool for the Black

- Sea. L. Ivanov and T. OGuz (eds.), Kluwer Academic Publishers, Netherlands, 1998. Vol.1, pp. 311-326.
- STANEV, E. V., J. V. STANEVA, I. G. GOSPODINOV Numerical tracer model of surface and intermediate water formation in the Black Sea. NATO TU-Black Sea Project: Ecosystem Modelling as a Management Tool for the Black Sea. L. Ivanov and T. OGuz (eds.), Kluwer Academic Publishers, Netherlands, 1998. Vol.2, pp.197-220.
 - STANEVA, J. V., E. V. STANEV, T. OGUZ The impact of atmospheric forcing and water column stratification on the yearly plankton cycle. NATO TU-Black Sea Project: Ecosystem Modelling as a Management Tool for the Black Sea. L. Ivanov and T. OGuz (eds.), Kluwer Academic Publishers, Netherlands, 1998. Vol.2, pp. 301-322.
 - STELMAKH, L. V., O. A. YUNEV, Z. Z. FINENKO, V. I. VEDERNIKOV, A. S. BOLOGA, T. YU. CHURILOVA Peculiarities of seasonal variability of primary production in the Black Sea. NATO TU-Black Sea Project: Ecosystem Modelling as a Management Tool for the Black Sea. L. Ivanov and T. OGuz (eds.), Kluwer Academic Publishers, Netherlands, 1998. Vol.1, pp. 93-104.
 - TKACH, A. V., A. D. GORDINA, U. NIERMANN, A. E. KIDEYS, V. E. ZAIKA Changes in nutrition of fish larvae with respect to plankton. NATO TU-Black Sea Project: Ecosystem Modelling as a Management Tool for the Black Sea. L. Ivanov and T. OGuz (eds.), Kluwer Academic Publishers, Netherlands, 1998. Vol.1, pp. 235-248.
 - UYSAL, Z., A. E. KIDEYS, L. SENICHKINA, L. GEORGIEVA, D. ALTUKHOV, L. KUZMENKO, L. MANJOS, E. MUTLU and E. EKER Phytoplankton patches formed along the Southern Black Sea coast in spring and summer of 1996. NATO TU-Black Sea Project: Ecosystem Modelling as a Management Tool for the Black Sea. L. Ivanov and T. OGuz (eds.), Kluwer Academic Publishers, Netherlands, 1998. Vol.1, pp. 151-162.
 - VINOGRADOV, M. E., E. A. SHUSKINA, L. P. LEBEDEVA, N. P. NEZLIN Structural and functional analysis of planktonic communities of the Black Sea NATO TU-Black Sea Project: Ecosystem Modelling as a Management Tool for the Black Sea. L. Ivanov and T. OGuz (eds.), Kluwer Academic Publishers, Netherlands, 1998. Vol.2, pp. 237-256.
 - VLADIMIROV, V., L., S. T. BESIKTEPE, D. G. AUBREY TU Black Sea Data Base Management System. NATO TU-Black Sea Project: Ecosystem Modelling as a Management Tool for the Black Sea. L. Ivanov and T. OGuz (eds.), Kluwer Academic Publishers, Netherlands, 1998. Vol.1, pp.1-10.
 - YAKUSHEV, E. V. Mathematical modelling of oxygen, nitrogen, sulfur and manganese cycling in the Black Sea. NATO TU-Black Sea Project: Ecosystem Modelling as a Management Tool for the Black Sea. L. Ivanov and T. OGuz (eds.), Kluwer Academic Publishers, Netherlands, 1998. Vol.2, pp. 373-384.
 - YILMAZ, A., O. A. YUNEV, V. I. VEDERNIKOV, S. MONCHEVA, A. S. BOLOGA, COCIASU, D. EDIGER Unusual temporal variations in the spatial distribution of chlorophyll-a in the Black Sea during 1990-96. NATO TU-Black Sea Project: Ecosystem Modelling as a Management Tool for the Black Sea. L. Ivanov and T. OGuz (eds.), Kluwer Academic Publishers, Netherlands, 1998. Vol.1, pp. 105-120.
 - ZAIKA, V. E. Spatial structure of the Black Sea benthic communities: influence of the pelagic processes. NATO TU-Black Sea Project: Ecosystem Modelling as a Management Tool for the Black Sea. L. Ivanov and T. OGuz (eds.), Kluwer Academic Publishers, Netherlands, 1998. Vol.1, pp.293-300.

Book Chapters in Press:

- NIERMANN U., A. E. KIDEYS, A. V. KOVALEV, V. MELNIKOV AND V. BELOKOPYTOV Long-term fluctuation of the zooplankton of the open Black Sea in comparison to other regions of the world. In: Environmental Degradation of the Black

- Sea: Challenges and Remedies, Constanta, Romania, October 6-10, 1997, A. Bologa, editor, Kluwer Acad. Publ., 1998. (in press)..
- OZSOY, E. and U. UNLUATA The Black Sea. in, *The Sea: The Global Coastal Ocean: Regional Studies and Synthesis*, A. Robinson and K. Brink (eds.), vol.11, Wiley Interscience Publ., (1998), (in Press).
 - BEZBORODOV, A. A., Z. P. BURLAKOVA, L. V. EREMEEVA, M. V. GULIN, A. A. LEBED Biochemical Processes Between Aerobic and Anaerobic Waters of the Black Sea. *Multidisciplinary Oceanographic Research of the Black Sea*, 1998. (in Press).
 - VLADIMIROV, V. L., V. V. MIROSHNICHENKO Multipurpose database management systems for the marine environmental research, in, N. Harmancioglu and N. N. Mikhaylov (eds.), *Proceedings of the NATO ARW*. Kluwer Academic Publishers, Dordrecht, 1998. (in press).
 - Conference Presentations: 1995 ALEXANDROV, B. G., Yu. P. ZAITSEV, Yu. A. ZAGORODNYAYA General characteristics, Report on the Biodiversity of the Ukrainian Black Sea Area. Istanbul, 1995. p.64-98, (in English).
 - GORDINA, A. D. On the Bluefish (*Pomatomus Saltatrix* L.) spawning and its eggs and larvae numbers in the Black Sea. *International Larval Fish Conference*, Sydney (Australia), 1995. Sydney, 1995, p.45.
 - IVANOV, L. I., S. BESIKTEPE, E. OZSOY, M. DUMAN, V. DIACONU, E. DEMIROV Recent changes in the Black Sea pycnocline. XXXIVe Congres-Assemblee Pleniere de la C.I.E.S.M., La Valette (Malta), 27-31 March 1995. *Rapp. Comm. int. Mer Medit.*, 34, (1995): 183.
 - KOCHERGIN, S., S. BESIKTEPE, L. M. IVANOV and E. OZSOY An inverse model of the Black Sea vertical mixing processes and the mixing parameterization. XXXIVe Congres-Assemblee Pleniere de la C.I.E.S.M., La Valette (Malta), 27-31 March 1995. *Rapp. Comm. int. Mer Medit.*, 34, (1995): 184.
 - MISHONOV, A. V., S. LUBARTSEVA Estimation of anthropogenic influence on the Black Sea hydrogen sulfide zone ecosystem, in, XII *International Symp. on Environmental Biogeochemistry*. Abstracts, Rio de Janeiro. Brasil. 1995. p.99.
 - MUTLU, E. Target strength of common jellyfish (*Aurelia aurita*: Scyphozoa): A preliminary empirical study with dual-beam acoustical system. *Symposium on Fisheries and Plankton Acoustics*, Aberdeen, Scotland (U. K.), 12-16, June 1995. in, *Books of Abstracts*, pp.65-66.
 - MUTLU, E. Hierarchical classification of macrobenthic molluscs in longshore waters of the Turkish Black Sea. *Twelfth International Malacological Congress*, Vigo (Spain), 3-8 September, 1995. in *Abstracts*, A. Guerra, E. Rolan and F. Rocha (eds.), Vigo, Spain, 1995. pp.221.
 - OGUZ, T. and P. MALANOTTE-RIZZOLI Seasonal variability of wind and thermohaline driven circulation in the Black Sea. *Workshop on Mediterranean Sea Circulation, Strait Exchange and Dense Water Formation Processes*, (dedicated to Antonio Michelato) 23-27 October, 1995.
 - OZSOY, E., T. COKACAR, A. MIKAELIAN, and S. T. BESIKTEPE Model studies and analysis of ecosystem dynamics of the Black Sea. *International Globec NMWG Meeting*, Nantes (France), 17-20 July 1995.
 - SUR, H. I., Y. GORYACHKIN, M. A. LATIF and E. OZSOY Sea level variations in response to water budgets and barometric pressure effects in the Black Sea. XXXIVe Congres-Assemblee Pleniere de la C.I.E.S.M., La Valette (Malta), 27-31 March 1995. *Rapp. Comm. int. Mer Medit.*, 34, (1995): 195.
 - SUR, H. I., Y. P. I. LYIN, E. OZSOY and V. I. IVANOV Surface layer currents and mesoscale thermal patterns in the Black Sea during April 1993. XXXIVe Congres-

Assemblée Plénière de la C.I.E.S.M., La Valette (Malta), 27-31 March 1995. Rapp. Comm. int. Mer Médit., 34, (1995): 196.

- VLADIMIROV, V. L., V. I. MANKOVSKY, A. V. MISHONOV Effects of anthropogenic activities on long-term variability of the bi-optical parameters of the Black Sea waters, in, XII International Symposium on Environmental Biogeochemistry. Biosphere and Atmospheric Changes. Abstracts, Rio de Janeiro, Brazil, 3-8 September, 1995, p.130.

1996

- BESIKTEPE, S., A. E. KIDEYS, M. UNSAL In situ grazing rate and diel vertical migration of female *Calanus euxinus* in the Black Sea. International PELAG Symposium on Eutrophication in Planktonic Ecosystems: Food Web Dynamics and Elemental Cycling, Helsinki (Finland), 26-30 August, 1996. in, Abstracts Book, p.18.
- COKACAR, T., U. UNLUATA, and E. OZSOY Modelling of ecosystem dynamics in the Black Sea. 28th International Liege Colloquium on Ocean Hydrodynamics, Liege (Belgium), 6-10 May, 1996. in, Abstracts Book, p.5.
- GEORGIEVA, L. V., L. G. SENICHKINA, L. V. KUZMENKO Report on the Biodiversity of the Ukrainian Black Sea Area. - Istanbul, Turkey, 1996 - 5.3. pp.44-63. (Programme Coordination Unit GEF Black Sea Environmental Programme), (in English)
- GORDINA, A. D., L. S. OVEN, I. I. RUDNEVA-TITOVA, A. V. TKACH, N. F. SHEVCHENNO Black Sea ichthyofauna in condition of anthropogenic stress. Sustainable developments: System analysis in ecology. 2nd Practical Conference, Sevastopol, Ukraine, September 9-12, 1996.
- GOUBANOVA, A. D., I. Yu. PRUSOVA, N. V. SHADRIN Dramatical changes in the copepod taxocenosis in the Sevastopol Bay (Black Sea) during the last decades (1976-1996). Report on 6th International Conf. on Copepoda, Oldenburg (Germany), July 29 - Aug. 3, 1996, (in English).
- KOVALEV, A. V., Yu. A. ZAGORODNYAYA, N. A. OSTROVSKAYA, A. D. GOUBANOVA, I. E. DRAPUN Changes of structure, distribution and production of crustacea (Copepoda and Cladocera). The Black Sea Through the Last Decades. 2nd European Crustacean Conference, Liege (Belgium), September 2-6. 1996. Abstracts. p.47, (in English).
- MUTLU, E. A preliminary study on biometry and size composition of *Mnemiopsis leidyi* (Ctenophora: Lobata) in the Black sea in space and time (1992-1994). 5th EMINAR, Klalpeda (Lithuania), 11-14 January, 1996. in Abstracts Book, (1996): p.11.
- NIERMANN, U., A. GORDINA, E. MUTLU, A. GUCU, A. KIDEYS, V. V. MELNIKOV, T. SHIGANOVA, A. KONSULOV, R. RADU Recent changes and long-term fluctuation in the Black Sea plankton community. First EROS-21 Workshop on the Interactions Between the Danube River and the North-Western Black Sea Shelf. First BSEP Assessment of Marine Pollution in the Black Sea, Istanbul (Turkey), 18-23 March, 1996.
- OGUZ, T., H. DUCKLOW, P. MALANOTTE-RIZZOLI, U. UNLUATA Simulation of annual plankton productivity cycle in the Black Sea by a coupled physical-biological model. ProDynamics'96. Progress in Theory and Applications of Modelling Aquatic Population Dynamics Workshop, Hamburg (Germany), 5-9 March, 1996.
- OGUZ, T., H. DUCKLOW, P. MALANOTTE-RIZZOLI, U. UNLUATA Simulation of annual plankton productivity cycle in the Black Sea by a coupled physical-biological model. 28th International Liege Colloquium on Ocean Hydrodynamics, Liege (Belgium), 6-10 May, 1996. in, Abstracts Book, p.31.

- OGUZ, T., H. DUCKLOW, P. MALANOTTE-RIZZOLI, U. UNLUATA Simulation of annual plankton productivity cycle in the Black Sea by a coupled physical-biological model. First EROS-21 Workshop on the Interactions Between the Danube River and the North-Western Black Sea Shelf. First BSEP Assessment of Marine Pollution in the Black Sea, Istanbul (Turkey), 18-23 March, 1996.
- OGUZ, T., H. DUCKLOW, P. MALANOTTE-RIZZOLI, U. UNLUATA Modeling plankton productivity and nutrient cycling in the Black Sea: Simulation with a 1-D vertically resolved, coupled physical-biological model. Modelling the Role of Zooplankton in the Marine Food Chain, University of Cambridge, Cambridge, (UK), 12-16 August, 1996.
- OSTROVSKAYA, N. A. Variability of sex structure and of reproduction rates in populations of the Black Sea Copepoda. Sixth International Conference on Copepoda, Oldenburg, Bremerhaven (Germany), July 29 - August 3, 1996. Abstracts of the papers, p.86, (in English).
- SALIHOGLU, I., et al. Influence of the Bosphorus outflow on the Black Sea. First EROS-21 Workshop on the Interactions Between the Danube River and the North-Western Black Sea Shelf. First BSEP Assessment of Marine Pollution in the Black Sea, Istanbul (Turkey), 18-23 March, 1996.
- TUGRUL, S., C. POLAT, and O. BASTURK Exchange of nutrients and organic material through the Bosphorus. First EROS-21 Workshop on the Interactions Between the Danube River and the North-Western Black Sea Shelf. First BSEP Assessment of Marine Pollution in the Black Sea, Istanbul (Turkey), 18-23 March, 1996.
- VLADIMIROV, V. L., V. I. MANKOVSKY, M. V. SOLOV'EV, A. V. MISHONOV, S. BESIKTEPE, E. OZSOY Optical parameters of the Black Sea waters: long-term variability and present status. Ocean Optics XIII, 22-25 October, 1996, Halifax, Nova Scotia (Canada). in, Ocean Optics XIII. Steven G. Ackleson, Robert Frauin, Editors, Proc. SPIE, 2963, pp. 560-565, 1997.
- YILMAZ, A., C. POLAT, D. EDIGER and S. TUGRUL On the production, elemental composition (C,N,P) and distribution of photosynthetic organic matter in the southern Black Sea. International PELAG Symposium on Eutrophication in Planktonic Ecosystems: Food Web Dynamics and Elemental Cycling, Helsinki (Finland), 26-30 August, 1996.
- YILMAZ, A., C. POLAT, D. EDIGER and S. TUGRUL Optical transparency, chlorophyll and primary productivity in the southern Black Sea. First EROS-21 Workshop on the Interactions Between the Danube River and the North-Western Black Sea Shelf. First BSEP Assessment of Marine Pollution in the Black Sea, Istanbul (Turkey), 18-23 March, 1996.

1997

- COKACAR, T. and E. OZSOY Comparative analyses and seasonal modelling for regional ecosystems of the Black Sea. With Rivers to the Sea. Interaction of Land Activities, Fresh Water and Enclosed Coastal Seas. 7th Stockholm Water Symposium 3rd International Conference on the Environmental Management of Enclosed Coastal Seas (EMECS), Stockholm City (Sweden), 10-15 August, 1997.
- ERKAN, F. and A. C. GUCU Acoustical estimation of the distribution and relative abundance of zooplankton in the southern Black Sea. Mediterranean Fisheries Congress, Izmir (Turkey), 9-11 April, 1997.
- OGUZ, T., P. MALANOTTE-RIZZOLI, H. W. DUCKLOW, M. E. VINOGRADOV, U. UNLUATA Modeling studies of the general circulation and biogeochemistry in the Black Sea performed within the framework of recent International research programs. Progress

in Oceanography of the Mediterranean Sea, Rome (Italy), 17-19 November, 1997. in, Abstracts Volume, pp. 239, 1997.

- OGUZ, T., B. SALIHOGLU, H. W. DUCKLOW, P. MALANOTTE-RIZZOLI, and U. UNLUATA Simulation of regional variability and seasonal fluctuations in phytoplankton biomass and productivity in the Black Sea ecosystem: Results from a baseline experiment. Progress in Oceanography of the Mediterranean Sea, Rome (Italy), 17-19 November, 1997. in, Abstracts Volume, pp. 239, 1997. (Poster presentation) UNLUATA, U Inter-regional co-operation on environmental issues: The Black Sea example, 6th European STRIDE (Inter-Regional Co-Operation and Research and Technological Development) Conference, Bremen (Germany), 3-4 February, 1997.

Papers Presented At NATO Advanced Research Workshop, Constantza (Romania), 6-10 October, 1997

- ALEXANDROV, B., Yu. ZAITSEV The Black Sea eutrophication: Special case of a global process. NATO Advanced Research Workshop, Constantza (Romania), 6-10 October, 1997. in, Abstracts 1997, pp.27.
- BASTURK, O., S. TUGRUL, and I. SALIHOGLU Characteristics of the biochemical cycles of the Black Sea. Environmental Degradation of the Black Sea: Challenges and Remedies. NATO Advanced Research workshop, Constantza (Romania), 6-10 October, 1997. in, Abstracts 1997, pp.22.
- BESIKTEPE, S., M. A. LATIF, T. OGUZ Water exchange through the Strait of Istanbul (Bosphorus) - recent observations. Environmental Degradation of the Black Sea: Challenges and Remedies. NATO Advanced Research workshop, Constantza (Romania), 6-10 October, 1997.
- BOLOGA, A. S., P. T. FRANGOPOL, V. I. VEDERNIKOV, L. V. STELMAKH, O. A. YUNEV, A. YILMAZ and T. OGUZ Planktonic primary production in the Black Sea. Environmental Degradation of the Black Sea: Challenges and Remedies. NATO Advanced Research workshop, Constantza (Romania), 6-10 October, 1997. in, Abstracts 1997, pp.38-39.
- DIACONU, V., A. COCIASU, E. DEMIROV, L. I. IVANOV Physical and chemical processes in the water masses of the western shelf areas of the Black Sea. NATO Advanced Research Workshop, Constantza (Romania), 6-10 October, 1997. in, Abstracts 1997, pp.11.
- KONOVALOV, S. K., J. W. MURRAY, L. I. IVANOV, L. V. EREMEEVA Black Sea eutrophication: A cause for changes in the hydrochemical structure of the anoxic zone. NATO Advanced Research Workshop, Constantza (Romania), 6-10 October, 1997. in, Abstracts 1997, pp. 16-21.
- NIERMANN, U., D. ALTUKHOV, A. V. KOVALEV, V. MELNIKOV, V. BELOKOPYTOV, A. E. KIDEYS Long-term fluctuations in the zooplankton of the open Black Sea in comparison to other regions of the world. Environmental Degradation of the Black Sea: Challenges and Remedies. NATO Advanced Research workshop, Constantza (Romania), 6-10 October, 1997. in, Abstracts 1997, pp.40-42.
- OGUZ, T., S. BESIKTEPE, P. MALANOTTE-RIZZOLI Black Sea circulation inferred from recent observations and modeling results. Environmental Degradation of the Black Sea: Challenges and Remedies. NATO Advanced Research workshop, Constantza (Romania), 6-10 October, 1997. in, Abstracts 1997, pp.13-14.
- OGUZ, T., H. DUCKLOW, P. MALANOTTE-RIZZOLI, J. MURRAY Interdisciplinary modelling on the plankton productivity, nutrient cycling and suboxic zone dynamics in the Black Sea. Environmental Degradation of the Black Sea: Challenges and Remedies.

- NATO Advanced Research workshop, Constantza (Romania), 6-10 October, 1997. in, Abstracts 1997, pp.56-57.
- SHIMKUS, K. M. Anthropogenic pollution and self-purification of the Black Sea in relationship with sedimentation processes. NATO Advanced Research Workshop, Constantza (Romania), 6-10 October, 1997. in, Abstracts 1997, pp.10.
 - SHULMAN, G. E., V. Y. SHCHEPKIN, G. S. MINYUK, A. Y. STOLBOV and E. V. IVLEVA The effect of anthropogenic impact on the physiology of the Black Sea fish. NATO Advanced Research Workshop, Constantza (Romania), 6-10 October, 1997. in, Abstracts 1997, pp. 43.
 - UNLUATA, U. NATO-TU black Sea Program and other NATO initiatives. Environmental Degradation of the Black Sea: Challenges and Remedies. NATO Advanced Research workshop, Constantza (Romania), 6-10 October, 1997. in, Abstracts 1997, pp.1.
 - VINOGRADOV, M. E, E. A. SHUSKINA, A. S. MIKAELIAN and N. P. NEZLIN Temporal (seasonal and interannual) changes of ecosystem of the open waters of the Black Sea. NATO Advanced Research Workshop, Constantza (Romania), 6-10 October, 1997. in, Abstracts 1997, pp. 29-32.
 - VLADIMIROV V. L., S. BESIKTEPE, D. G. AUBREY NATO TU-Black Sea interdisciplinary data base. Environmental Degradation of the Black Sea: Challenges and Remedies. NATO Advanced Research workshop, Constantza (Romania), 6-10 October, 1997. in, Abstracts 1997, pp.2-4.
 - VLADIMIROV, V. I., V. I. MANKOVSKY, S. T. BESIKTEPE, M. V. SOLOV'EV, A. V. MISHONOV Hydro-optical studies of the Black Sea: History and status. Environmental Degradation of the Black Sea: Challenges and Remedies. NATO Advanced Research workshop, Constantza (Romania), 6-10 October, 1997. in, Abstracts 1997, pp.24-26.
 - YAKUSHEV, E. V. Modelling of redox processes in the Black Sea. NATO Advanced Research Workshop, Constantza (Romania), 6-10 October, 1997. in, Abstracts 1997, pp. 58-60.
 - ZAIKA, V. I., N. G. SEGEEVA Cold-water communities of the Black Sea. NATO Advanced Research Workshop, Constantza (Romania), 6-10 October, 1997. in, Abstracts 1997, pp. 28.

1998

- GUCU, A. C. and T. OGUZ Modeling trophic interrelations in the Black Sea. GLOBEC, First Open Science Meeting, Paris (France), 17-20 March 1998.
- OGUZ, T., H. W. DUCKLOW, P. MALANOTTE-RIZZOLI, and U. UNLUATA Simulation of recent changes in the functioning of ecosystem and the upper layer biochemical structure of the Black Sea. GLOBEC, First Open Science Meeting, Paris (France), 17-20 March 1998.
- OZSOY, E. Sensitivity to global change in temperate Eurasian Seas (the Mediterranean, Black Sea and Caspian Sea): Presented in the NATO Advanced Research Workshop The Eastern Mediterranean as a Laboratory Basin for the Assessment of Contrasting Ecosystems, Kiev (Ukraine), 23-27 March 1998.

APPENDIX I

Scientific paper on **Water and Nitrate Budgets**

Leviel B., Gabrielle B., Justes E., Mary B. & Gosse G. 1998. Water and nitrate budgets in a rendzina cropped with oilseed rape receiving varying amounts of fertilizer. *European Journal of Soil Science* **49**:37-51.